



Count on it.

Parts Catalog

TimeMaster 76cm

Lawn Mower

Model No. 21810—Serial No. 411743171 and Up



Ordering Replacement Parts

To order replacement parts, please supply the part number, the quantity, and the description of each part desired.

Understanding Reference Numbers

Each identified part in an illustration has a reference number. The reference number for a part also appears in the parts list, along with other information about the part.

This catalog uses two special reference number formats, one to indicate parts in a service assembly and another to indicate the quantity of a given part in an illustration.

Service Assembly Reference Numbers

Parts in service assemblies have reference numbers in the form a:b. The a represents the reference number of the entire service assembly and the b represents a sequential number unique to each part within the service assembly.

For example, a wheel assembly might be identified by reference number 6, the tire by 6:1, the valve by 6:2, and the wheel by 6:3. When you order the assembly identified by reference number 6, you receive all parts identified by reference numbers 6:1, 6:2, and 6:3. However, you may also order any part individually. Reference numbers of this type appear in illustration and in parts lists.

Reference Numbers Indicating Quantity

In an illustration, if a reference number indicates more than one part, the reference number has the form nX y. The n represents the quantity of the part, the X is the multiplication symbol, and the y represents the reference number.

For example, in an illustration, the reference number 2X 37 means that two of the parts identified by reference number 37 are indicated.

Contents

Housing Assembly	4
Spindle and Belt Assembly	6
Side Discharge Chute Assembly	8
Bag Assembly	10
Engine and Belt Assembly	12
Front Wheel and Height-of-Cut Assembly	14
Rear Wheel and Height-of-Cut Assembly	16
Handle and Electrical Assembly	18
Attachments and Accessories	20

Housing Assembly

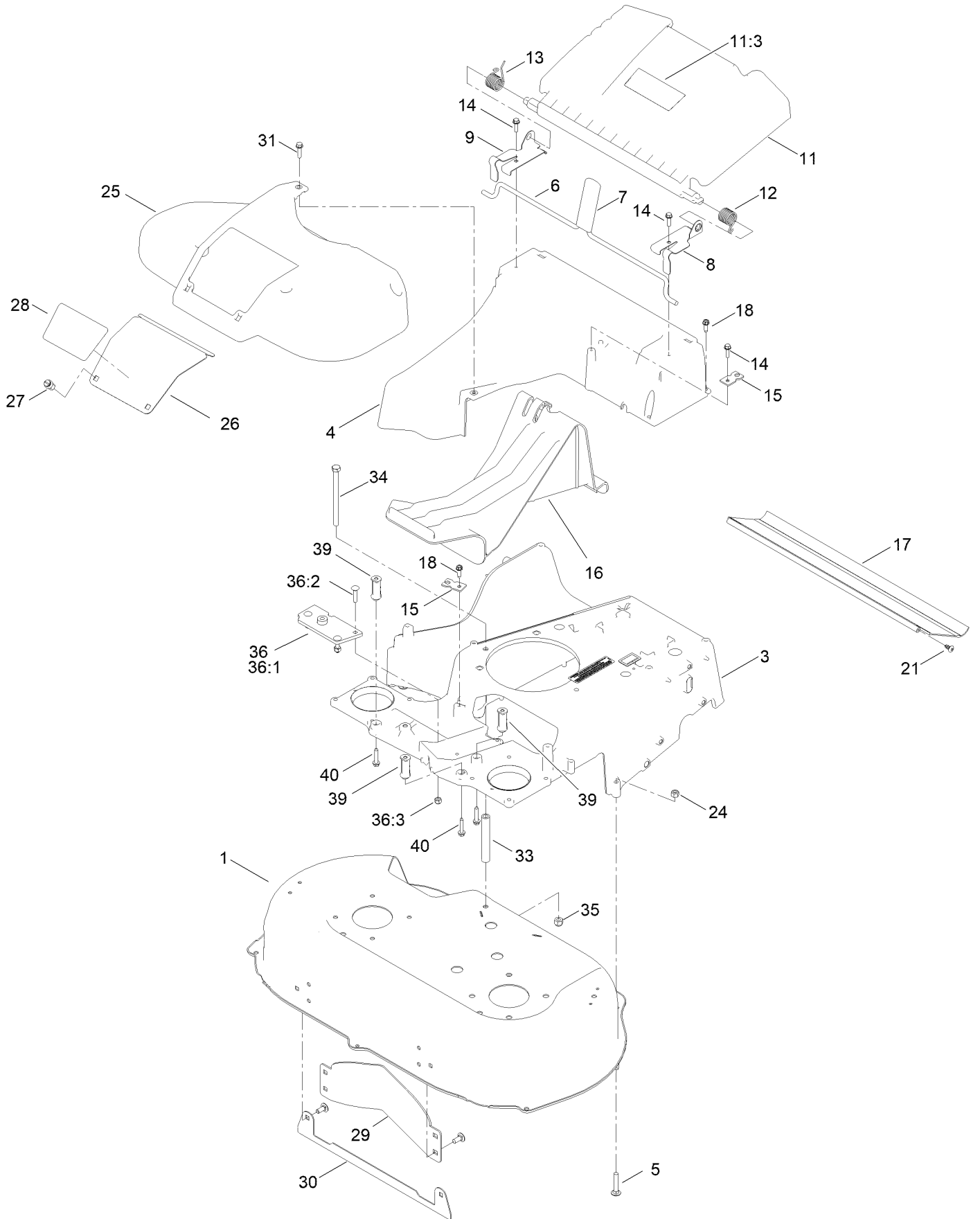

Housing Assembly (continued)

<i>Ref.</i>	<i>Part Number</i>	<i>Qty.</i>	<i>Description</i>	<i>Ref.</i>	<i>Part Number</i>	<i>Qty.</i>	<i>Description</i>
1	136-5874	1	Housing ASM	24	119-4038	2	Nut-Hex
3	140-3977-01	1	Frame-30"	25	139-5406	1	Cover-Belt
4	133-8177	1	Chute	26	121-5793-03	1	Door-Access
5	137-3063	2	Bolt-Car	27	121-5840	2	Fastener
6	139-5415	1	Rod-Release, Handle	28	125-2507	1	Decal-Access Panel
7	120-7018	1	Grip-Lever	29	130-2352-01	1	Baffle-Control
8	121-9114	1	Bracket-Door, LH	30	125-5081-01	1	Plate-Deck
9	121-9115	1	Bracket-Door, RH	31	32144-86	1	Screw-HWHTF
11	120-7048	1	Rear Deflector ASM	33	139-5498	1	Spacer-Shield
11:3	131-4514	1	Decal-Warning	34	139-5409	1	Screw-HH
12	115-2859	1	Spring-Torsion	35	137-3087	1	Nut-Hex
13	114-7924	1	Spring-Torsion	36	125-5072	1	Frame Plate Kit
14	137-3099	3	Screw-Plastite, HWH	36:1	125-2542	1	Plate-Frame
15	138-3224	2	Bracket-Cable, Traction	36:2	3229-3	3	Screw-CARR
16	120-5225	1	Plug-Mulch	36:3	3296-42	3	Nut-Lock, NI
17	120-6241	1	Shield-Trailing	39	140-3901	3	Spacer-Frame, 30 In.
18	49-2040	8	Screw-HWHTF	40	108-4862	3	Screw-HWH Thd Roll
21	139-1692	2	Screw-Thd				

Spindle and Belt Assembly

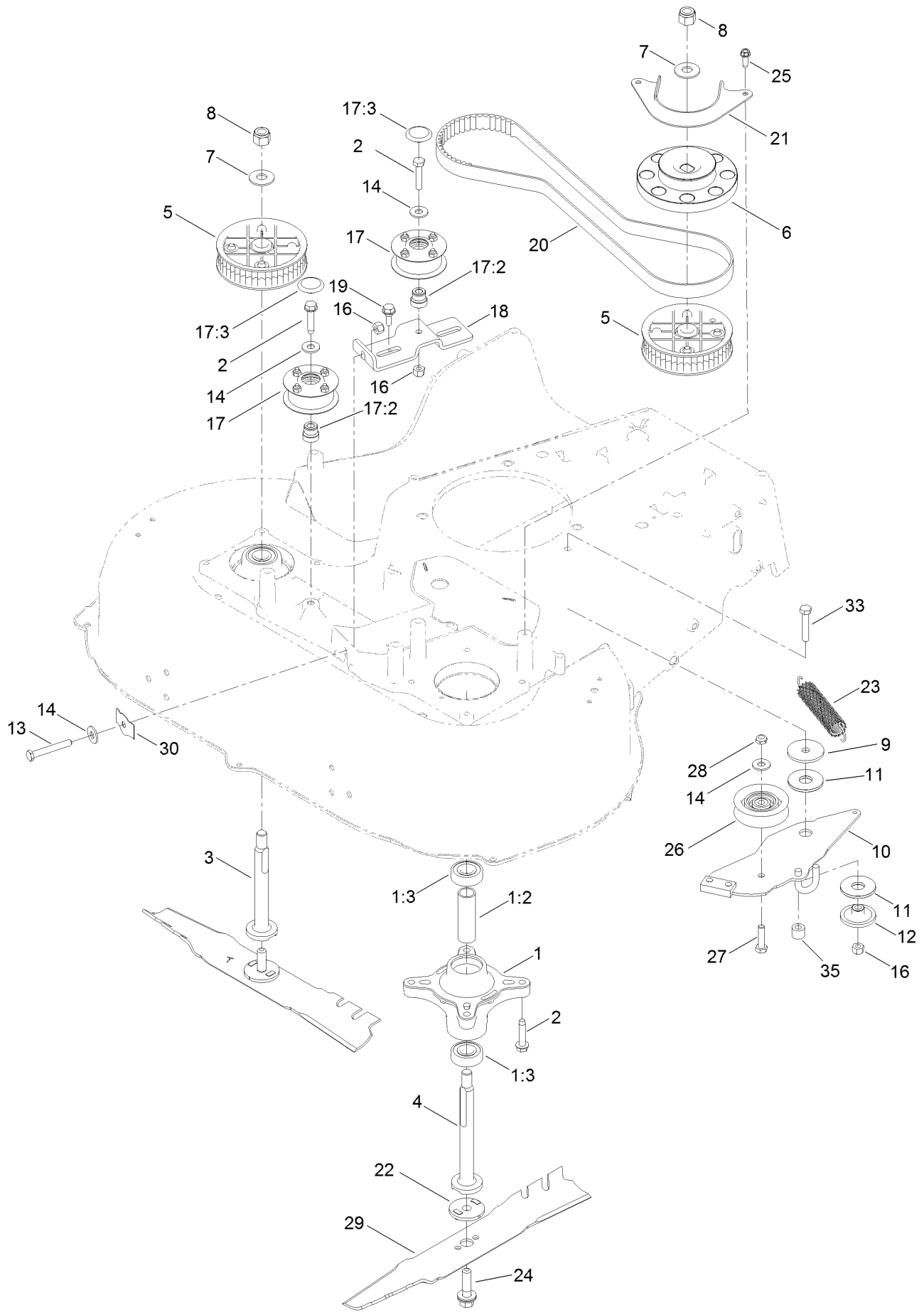

Spindle and Belt Assembly (continued)

<i>Ref.</i>	<i>Part Number</i>	<i>Qty.</i>	<i>Description</i>	<i>Ref.</i>	<i>Part Number</i>	<i>Qty.</i>	<i>Description</i>
1	121-9107	2	Spindle ASM	17:2	131-4504	1	Adapter-Bore
1:2	120-7935	2	Spacer	17:3	125-2533	1	Plug-Cap
1:3	136-5441	2	Bearing-Ball	18	138-3232	1	Bracket-Idler
2	139-1731	9	Screw-Thd Roll, HWH	19	139-1730	2	Screw-Shoulder, HHF
3	139-6612	1	Shaft-Spindle	20	120-3335	1	Belt-Synchronous
4	139-6613	1	Shaft-Spindle	21	120-5245-03	1	Guide-Belt, Spindle
5	121-9100	2	Sprocket	22	120-5236	2	Adapter-Blade
6	130-6664	1	Pulley-Brake, Spindle	23	121-5808	1	Spring-Extension, Brake
7	109-9505	2	Washer-Spring	24	125-2466	2	Bolt-Blade
8	139-1725	2	Nut-Hex	25	49-2040	2	Screw-HWHTF
9	139-1726	1	Washer-Rebound	26	120-7082	1	Pulley-Idler
10	133-8102	1	Brake Arm ASM	27	120-9696	1	Screw-HH
11	121-2305	2	Washer-Friction, Composite	28	137-3089	1	Nut-Hex
12	138-3244	1	Spacer	29	116-6358-03	2	Blade-Rotary
13	139-1728	1	Bolt-HH Ft	30	121-2336	1	Spring-Flat
14	139-1723	4	Washer-Flat	33	139-1719	1	Screw-HH
16	119-4038	3	Nut-Hex	35	133-1964	1	Spacer
17	139-1758	2	Pulley Kit				

Side Discharge Chute Assembly

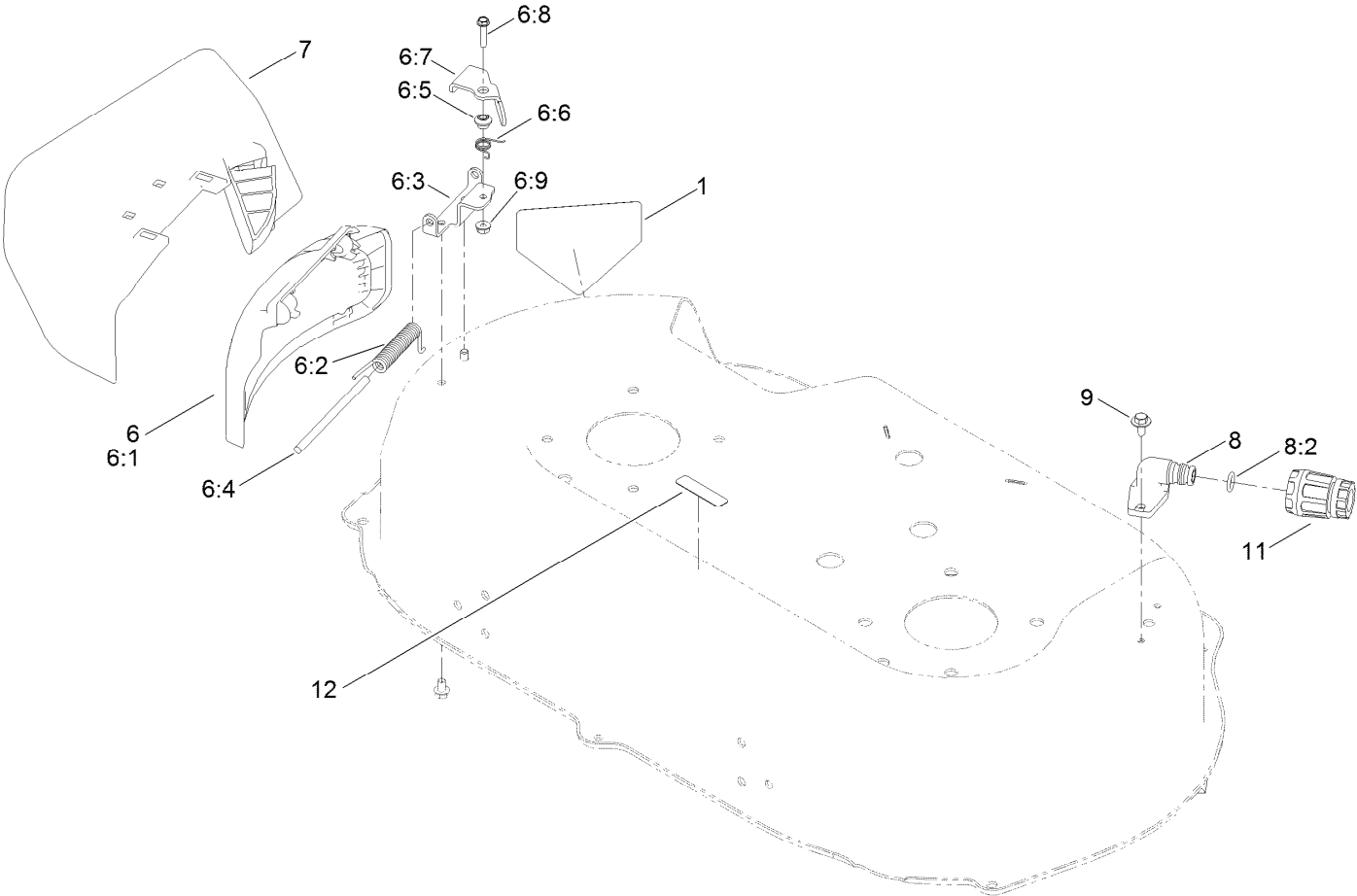

Side Discharge Chute Assembly (continued)

<i>Ref.</i>	<i>Part Number</i>	<i>Qty.</i>	<i>Description</i>	<i>Ref.</i>	<i>Part Number</i>	<i>Qty.</i>	<i>Description</i>
1	112-8760	1	Decal-Danger	6:8	106-9169	1	Screw-HWH
6	138-5325	1	Side Deflector Service ASM	6:9	32128-17	1	Nut-Lock, Flange
6:1	138-5317	1	Deflector-Discharge, Side	7	139-5416	1	Side Discharge Chute ASM
6:2	127-0721	1	Spring-Torsion, Cover	8	133-9289	1	Fitting-Washout
6:3	138-3293	1	Bracket-Lockout	8:2	133-9290	1	O-Ring
6:4	99-5291	1	Rod-Cover	9	139-1700	2	Screw-HWH, Thd Roll
6:5	107-7463	1	Spacer	11	95-3270	1	Connector-Hose
6:6	107-7462	1	Spring-Torsion	12	120-9570	1	Decal-Warning
6:7	138-3292	1	Lever-Lockout				

Bag Assembly



Bag Assembly (continued)

<i>Ref.</i>	<i>Part Number</i>	<i>Qty.</i>	<i>Description</i>
1	121-5766-03	1	Frame-Bag
2	121-5770	1	Bag-Grass

Engine and Belt Assembly

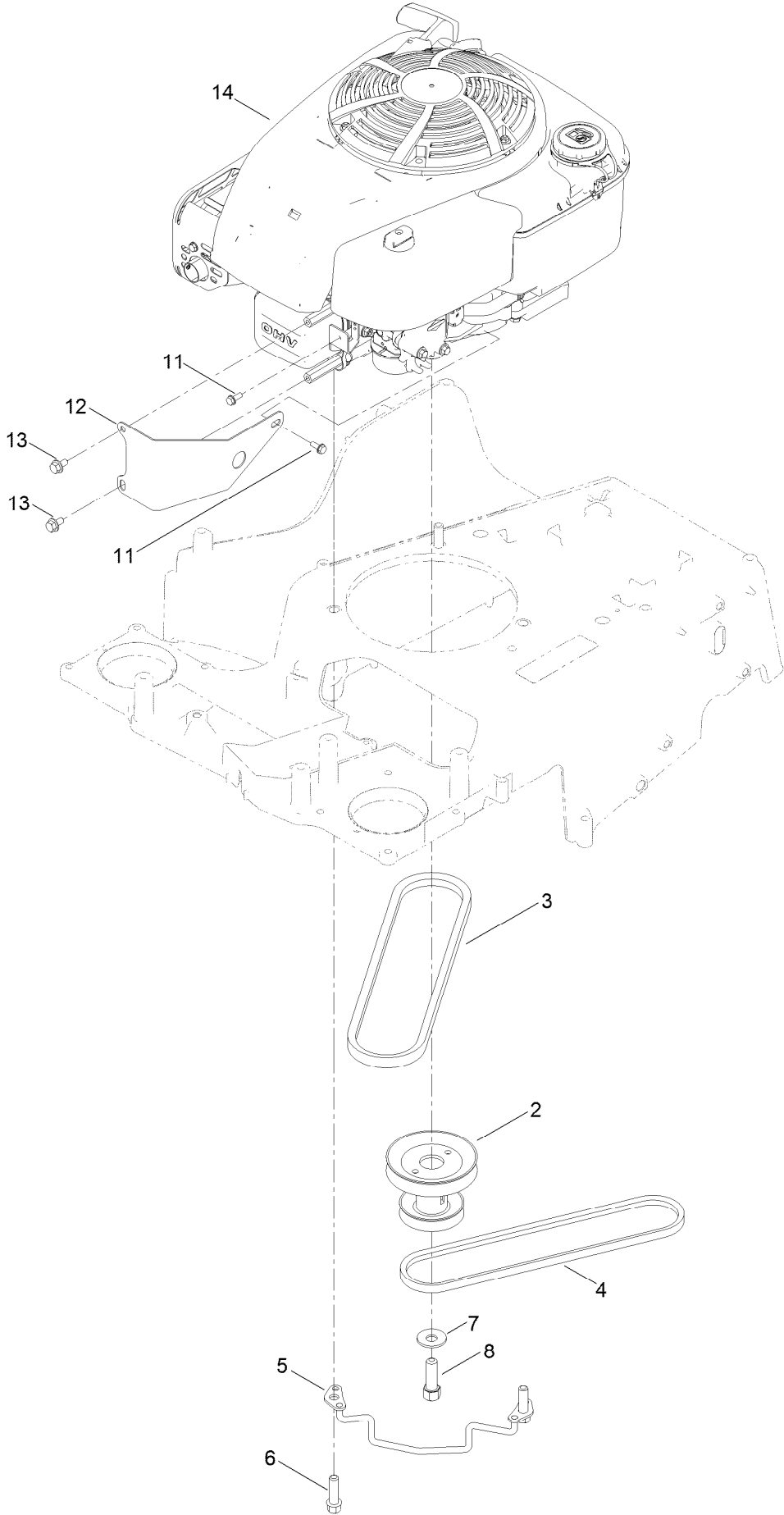

Engine and Belt Assembly (continued)

<i>Ref.</i>	<i>Part Number</i>	<i>Qty.</i>	<i>Description</i>	<i>Ref.</i>	<i>Part Number</i>	<i>Qty.</i>	<i>Description</i>
2	137-9176	1	Pulley-Engine	8	26-0671	1	Screw-HH
3	121-5765	1	V-Belt	11	139-1713	2	Screw-Taptite
4	120-9470	1	V-Belt, Traction	12	131-0889-03	1	Guard-Engine
5	139-1734	1	Guide-Belt, Wa	13	126-2713	2	Screw-HHF
6	95-1727	3	Screw-Taptite	14		1	Engine-Briggs, 14D9320112F1 ● ■
7	3290-465	1	Washer-Belleville				

● Not serviced separately

■ Obtain parts from www.briggsandstratton.com

Front Wheel and Height-of-Cut Assembly

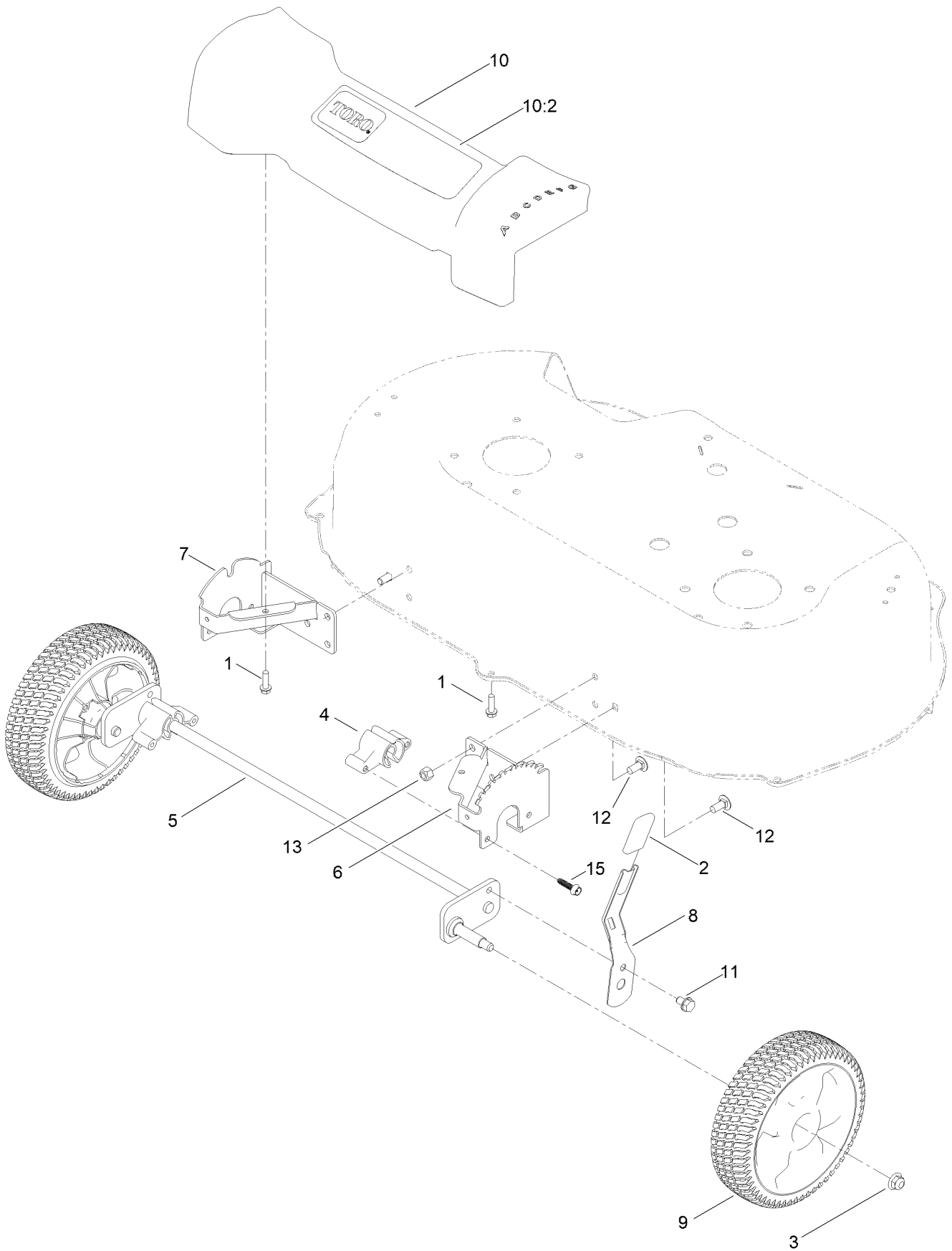

Front Wheel and Height-of-Cut Assembly (continued)

<i>Ref.</i>	<i>Part Number</i>	<i>Qty.</i>	<i>Description</i>	<i>Ref.</i>	<i>Part Number</i>	<i>Qty.</i>	<i>Description</i>
1	137-3099	3	Screw-Plastite, HWH	9	125-2510	2	8 Inch Wheel ASM
2	120-9535	1	Grip-Lever	10	125-5027	1	Front Cover ASM
3	119-4042	2	Nut-HF, NI	10:2	121-2392	11	Decal-Cover, Front
4	136-5875	2	Bushing-Pivot, Front	11	139-1727	1	Screw-HWH, Thd Roll
5	139-1753	1	Front Axle ASM	12	137-3061	6	Bolt-CARR
6	120-7037-03	1	Plate-HOC, LH	13	119-4038	6	Nut-Hex
7	120-7038-03	1	Plate-HOC, RH	15	130-6658	4	Screw-Flange, Plastic
8	120-7043	1	Arm-Spring				

Rear Wheel and Height-of-Cut Assembly

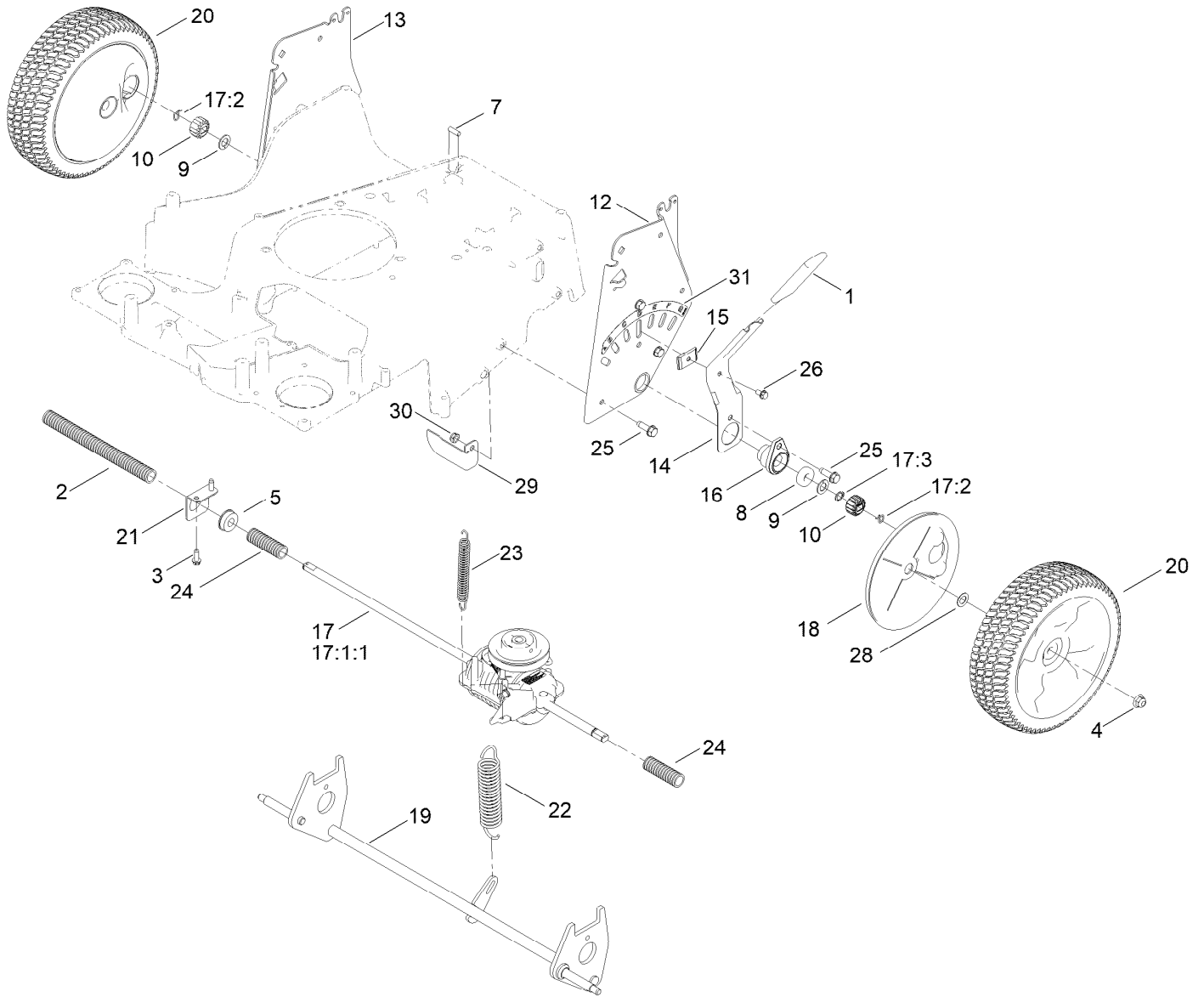

Rear Wheel and Height-of-Cut Assembly (continued)

<i>Ref.</i>	<i>Part Number</i>	<i>Qty.</i>	<i>Description</i>	<i>Ref.</i>	<i>Part Number</i>	<i>Qty.</i>	<i>Description</i>
1	137-4796	1	Grip-Lever, Lift	17:2	130-2369	2	Pin-Snap
2	121-5799	1	Conduit-Convolute	17:3	32151-61	1	Ring-Retaining
3	49-2040	2	Screw-HWHTF	18	120-6233	2	Cover-Gear
4	119-4042	2	Nut-HF, NI	19	139-1747	1	Rear Axle ASM
5	104-8699	1	Bearing-Ball	20	125-2509	2	10 Inch Wheel Gear ASM
7	106-5681	1	Pin-Stop	21	138-3233	1	Mount-Bearing
8	133-2603	2	Bearing-Ball	22	120-7026	1	Spring-Extension
9	110-7191	2	Washer-Thrust	23	120-7027	1	Spring-Extension
10	131-5399	2	Gear-Pinion, 15T	24	121-5800	2	Conduit-Convolute
12	120-3342-03	1	Plate-HOC, LH	25	701243	8	Screw-Thd Roll, HWH
13	120-3343-03	1	Plate-HOC, RH	26	32144-4	1	Screw-HWH
14	137-9124	1	Arm-Spring	28	36-4780	2	Washer-Plain
15	120-5209	1	Key-Arm, Spring	29	138-5338	1	Bracket-Stop
16	136-5929	2	Retainer-Bearing	30	137-3089	1	Nut-Hex
17	131-9665	1	Transmission Kit	31	125-2497	1	Decal-HOC, Rear
17:1:1	130-2370	1	Transmission Pulley Kit				

Handle and Electrical Assembly

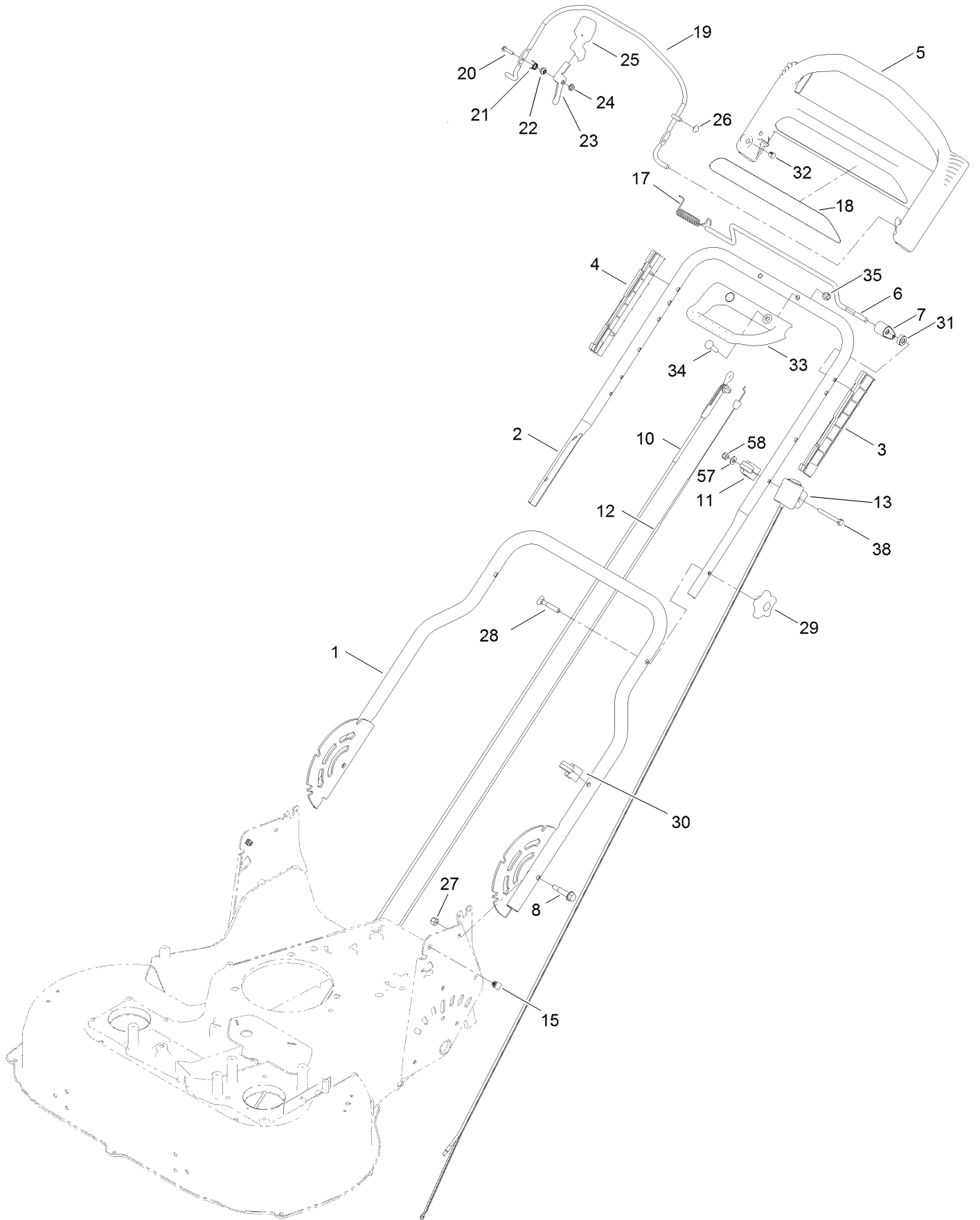

Handle and Electrical Assembly (continued)

<i>Ref.</i>	<i>Part Number</i>	<i>Qty.</i>	<i>Description</i>	<i>Ref.</i>	<i>Part Number</i>	<i>Qty.</i>	<i>Description</i>
1	120-5204-05	1	Handle-Lower	22	107-7463	1	Spacer
2	132-4484-05	1	Handle-Upper	23	138-3220	1	Lever
3	105-6842	1	Guide-LH	24	139-1712	1	Nut-Hex Flange
4	105-6841	1	Guide-RH	25	112-8884	1	Knob
5	104-8678	1	Handle-Control	26	3290-337	1	Nut-Speed
6	136-7150	1	Bar-Control, Traction	27	119-4038	2	Nut-Hex
7	127-6842	1	Lever-Traction	28	137-3107	2	Screw-Handle
8	139-1694	2	Bolt-Shoulder, HHF	29	117-5976	2	Knob-Handle
10	133-1998	1	Cable-Brake	30	114-7988	1	Guide-Cable
11	136-5864	1	Anchor-Cable	31	130-2343	1	Spacer
12	127-6867	1	Cable-Traction	32	104-9368	1	Plug-Dome
13	117-5975	1	Switch Housing ASM	33	131-0847	1	Handle-Assist, Traction
15	132-4516	2	Plug-Square	34	139-1702	2	Bolt-Carriage
17	136-7166	1	Spring-Torsion	35	137-4808	2	Nut-Acorn
18	120-3911	1	Decal-Handle	38	137-3034	1	Screw-HH
19	108-3788-03	1	Bail-Brake	57	139-1699	1	Washer-Flat
20	106-9169	1	Screw-HWH	58	137-3094	1	Nut-Hex
21	107-7462	1	Spring-Torsion	99	614249	2	Tie-Cable ●

● Not illustrated

Attachments and Accessories

For 21810 TimeMaster 76cm Lawn Mower

Product Name	Model/Part
Fuel Stabilizer .05 oz	130-2393
4-Cycle Fuel, Snow And Lawn 32oz Can	131-3823
Toro Premium Fuel Treatment 12 Oz Bottle	131-6572
Oil-30/10W-30 Synthetic (Quart).....	138-6053
Hi-Lift Repl Blade Kit Timemaster	20122P
Lawn Striping Kit with 30in Roller.....	20602
Toro 4-Cycle SAE 30 Oil (32oz Bottle)	38903
Summer Oil-Case of 24 (20oz Bottles).....	38916
Bag-Walk Behind (Toro).....	490-7318
Mower Cover	490-7461

Notes:

Notes:

Notes:



Count on it.