



**42" Rear Discharge Mower
Wheel Horse[®] Classic Garden Tractor
Attachment**

Model No. 78350—Serial No. 22000001 and Up

Operator's Manual

Contents

	Page
Introduction	2
Slope Chart	3
Safety and Instruction Decals	5
Setup	6
Loose Parts	6
Attaching the Adjustable Link	6
Installing the Mower	6
Checking the Front-to-Rear Blade Slope	8
Transport Height Adjustment	8
Operating the Power Take Off (PTO)	9
Operating the Attachment Lift Lever	9
Operating the Attachment Power Lift	10
Adjusting Height-of-Cut	10
Removing the Mower	11
Tips for Mowing Grass	12
Maintenance	12
Recommended Maintenance Schedule	13
Servicing the Cutting Blades	13
Greasing and Lubrication	15
Servicing the Blade Drive Belt	15
Replacing the Power Take Off (PTO) Belt	16
Cleaning and Storage	18
Troubleshooting	19

Introduction

Read this manual carefully to learn how to operate and maintain your product properly. The information in this manual can help you and others avoid injury and product damage. Although Toro designs and produces safe products, you are responsible for operating the product properly and safely.

Whenever you need service, genuine Toro parts, or additional information, contact an Authorized Service Dealer or Toro Customer Service and have the model and serial numbers of your product ready. Figure 1 illustrates the location of the model and serial numbers on the product.

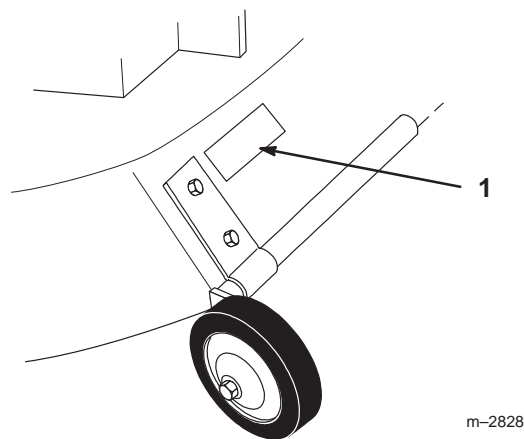

Figure 1

1. Location of the model and serial numbers

Write the product model and serial numbers in the space below:

<p>Model No. _____</p> <p>Serial No. _____</p>
--

This manual identifies potential hazards and has special safety messages that help you and others avoid personal injury and even death. **Danger**, **Warning**, and **Caution** are signal words used to identify the level of hazard. However, regardless of the hazard, be extremely careful.

Danger signals an extreme hazard that *will* cause serious injury or death if you do not follow the recommended precautions.

Warning signals a hazard that *may* cause serious injury or death if you do not follow the recommended precautions.

Caution signals a hazard that may cause minor or moderate injury if you do not follow the recommended precautions.

This manual uses two other words to highlight information.

Important calls attention to special mechanical information and **Note:** emphasizes general information worthy of special attention.

Slope Chart

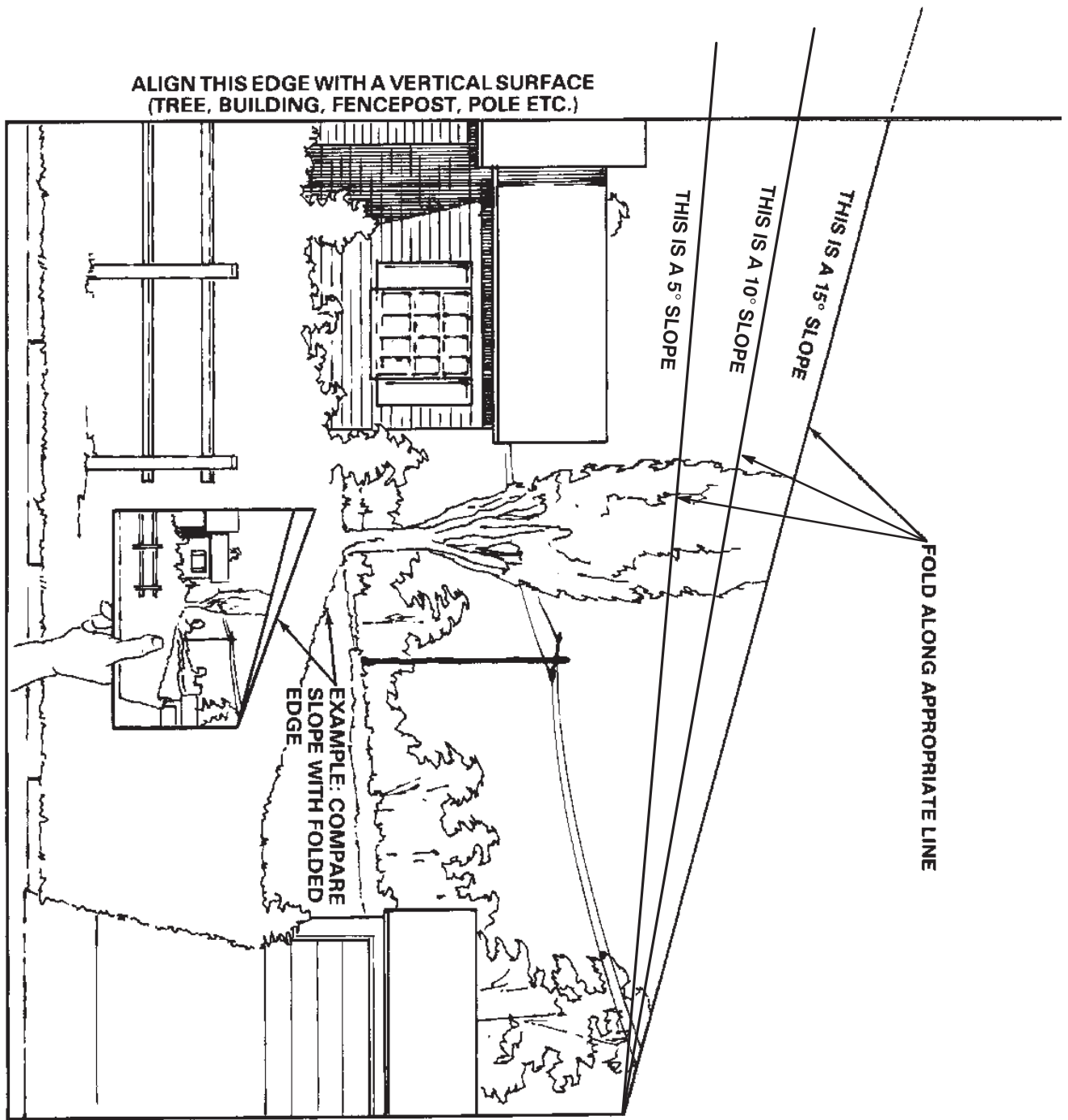

Safety and Instruction Decals



Safety decals and instructions are easily visible to the operator and are located near any area of potential danger. Replace any decal that is damaged or lost.



43-8480



92-7108

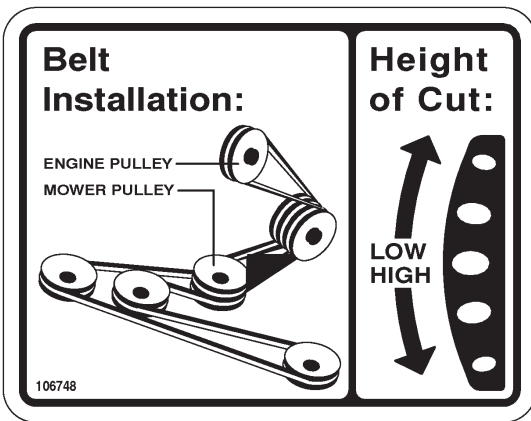

106748

Setup

Note: Determine the left and right sides of the machine from the normal operating position.

Loose Parts

Note: Use the chart below to identify parts used for assembly.

DESCRIPTION	QTY.	USE
Height-of-cut lever	1	Install height-of-cut lever
Spring	1	
V belt	1	Installing the mower
Idler assembly	1	
Belt cover	1	
Locknut	1	
Operator's Manual	1	Read before operating

Attach Height-of-Cut Lever

1. Loosen nuts securing quadrant to mower(Fig. 2).
2. Place spring onto long pin of lever. Compress spring and slide lever into square tube. Insert short pin of lever into a quadrant hole hold in position. Tighten quadrant nuts (Fig. 2).

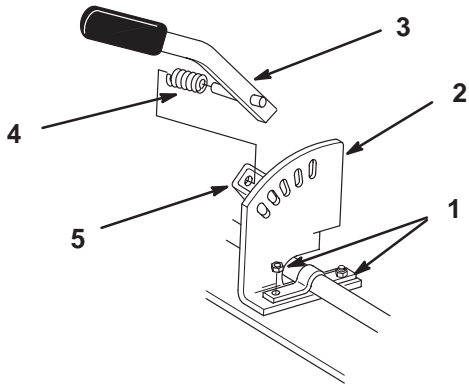

Figure 2

1. Nut
2. Quadrant
3. Height-of-Cut lever
4. Spring
5. Square tube

m-2834

Attaching the Adjustable Link

1. Place adjustable link trunnion into rear wheel shaft bracket and secure with hairpin cotter and washer (Fig. 3).

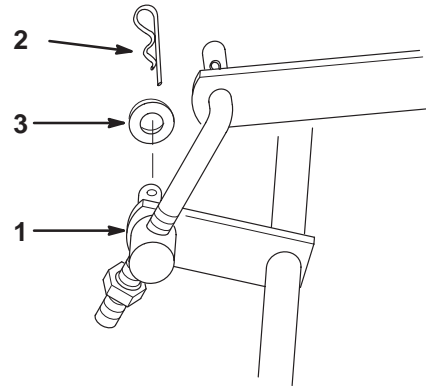

Figure 3

1. Adjustable link trunnion
2. Hairpin cotter
3. Washer

m-5618

Installing the Mower

1. Park the machine on a level surface, disengage the power take off (PTO), set the parking brake, and turn the ignition key to off. Remove the key.

- Turn the front wheels fully to the left and raise attachment lift lever all the way to the latched position; refer to tractor Operator's Manual.
- Open front and mid-mount hitches by pushing release button and moving lock handles forward (Fig. 4).

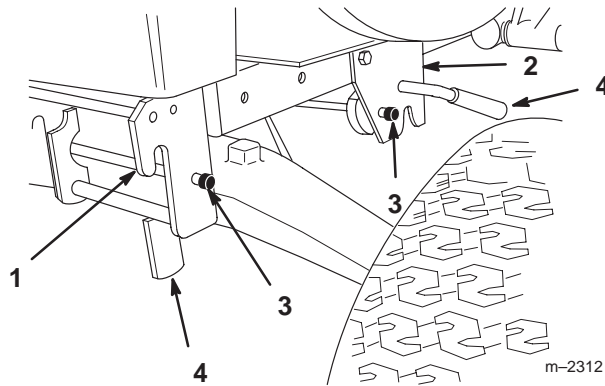

Figure 4

- | | |
|--------------------|-------------------|
| 1. Front hitch | 3. Release button |
| 2. Mid-mount hitch | 4. Lock handle |

- Slide the mower under the chassis from the right side and align attachment lift with slot in center level bar (Fig. 5).
- Straighten the front wheels, turn Dial-A-Height knob counterclockwise, all the way, and lower the attachment lift lever to the mounting position; refer to tractor Operator's Manual.
- Place attachment lift pin into slot in center lever bar and secure with a washer (3/4 in.) and a hairpin cotter (Fig. 5).

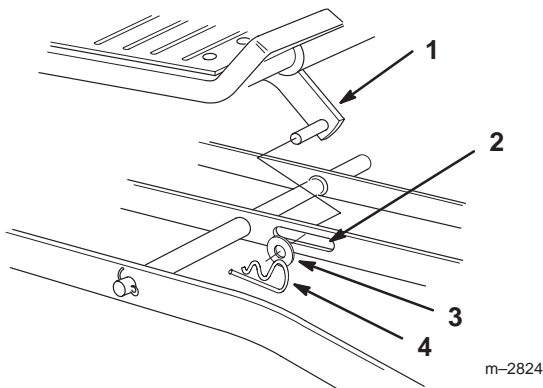

Figure 5

- | | |
|--------------------------|--------------------|
| 1. Attachment lift | 3. Washer |
| 2. Slot-center level bar | 4. Hair pin cotter |

- Rotate front mounting shaft so fork faces up and align so spacers are between mid-mount hitch plates (Fig. 6).
- Lift mower with attachment lift and guide fork to capture hitch rod (Fig. 6). Close mid-mount hitch lock handle.

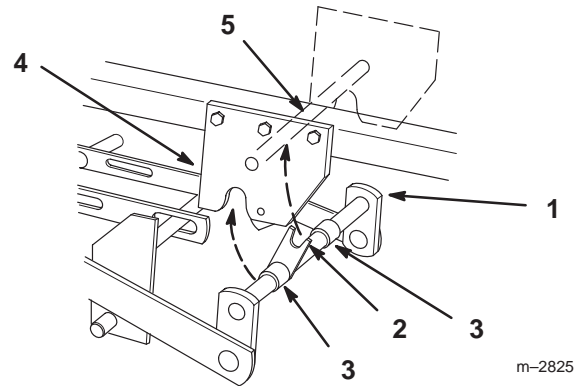

Figure 6

- | | |
|-------------------------|--------------------------|
| 1. Front mounting shaft | 4. Mid-mount hitch plate |
| 2. Fork | 5. Hitch rod |
| 3. Spacer | |

- Install the belt onto the clutch. Refer to Replace the PTO Belt on page 16.
- Place pulley assembly into front hitch and lock by moving latch rearward (Fig. 7).

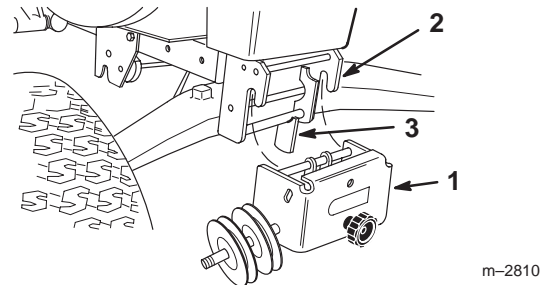

Figure 7

- | | |
|--------------------|----------|
| 1. Pulley assembly | 3. Latch |
| 2. Front hitch | |

- Route belt around V and flat pulleys and loop over center mower spindle, top pulley.(Fig. 8).
- Check that spacer is on shaft and install belt cover with rod in hole. Secure with locknut (Fig. 8).
- Turn knob counterclockwise to tighten belt (Fig. 8). Tighten until there is 1 in. (26 mm) belt movement between engine clutch and idler pulley when slight pressure is applied to the belt.

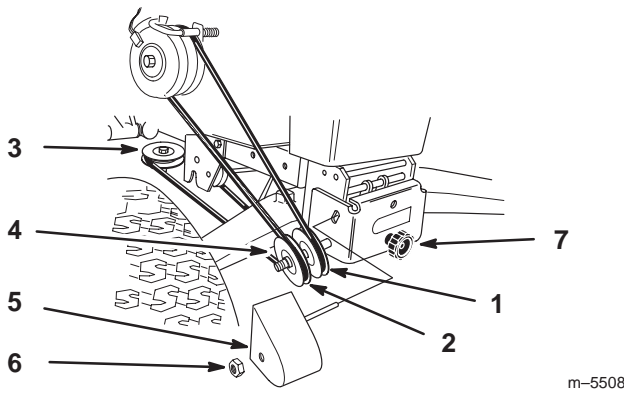

Figure 8

- | | |
|-----------------------|---------------|
| 1. V pulley | 5. Belt cover |
| 2. Flat pulley | 6. Locknut |
| 3. Upper mower pulley | 7. Knob |
| 4. Spacer | |

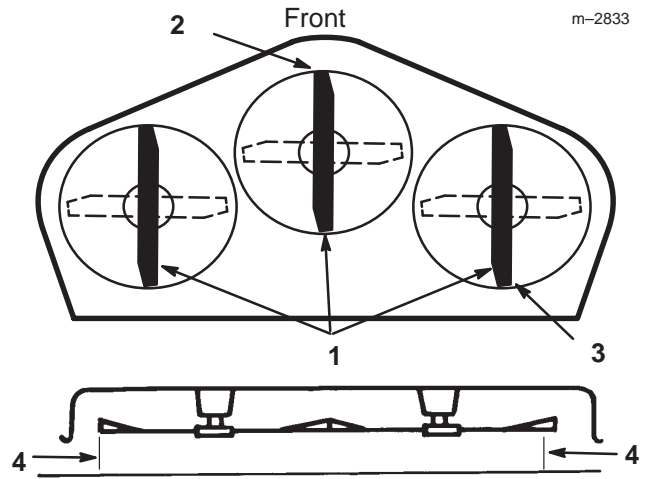

Figure 9

- | | |
|----------------------------|---------------------------|
| 1. Blade front to rear | 3. Measure rear blade tip |
| 2. Measure front blade tip | 4. Measure here |

14. Install belt cover (Fig. 16).

Checking the Front-to-Rear Blade Slope

Check the front-to-rear blade slope any time you install the mower. Before checking the slope, set air pressure in the front and rear tires to 12 psi (85 kPa). If the front blade tip is not 1/8–1/4 in. (4–7 mm) lower than the rear blade tip, adjust the blade slope using the following instructions:

1. Park the machine on a level surface, disengage the power take off (PTO), set the parking brake, and turn the ignition key to off. Remove the key.
2. Adjust height-of-cut lever on mower to the middle of the range and lower attachment lift.
3. Carefully rotate blades so they are facing front and rear (Fig. 9).
4. Measure between the tip of the front blade (Fig. 9) and the tip of the rear blade to the flat surface. If the front blade tip is not 1/8–1/4 in. (4–7 mm) lower than the rear blade tip adjust rear adjustment link.

5. To adjust front-to rear blade slope turn locknut on rear adjustable link (Fig. 10).

Note: To raise the front of the mower, turn locknut clockwise, to lower front turn counterclockwise.

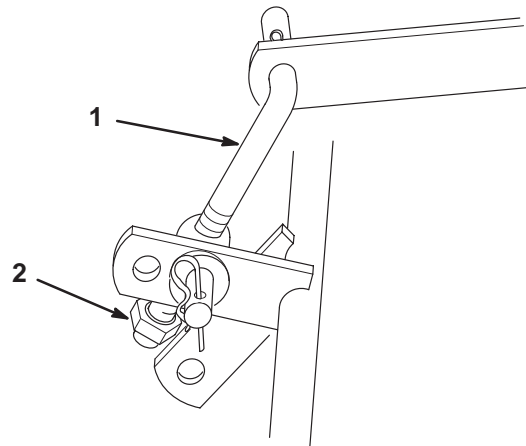

Figure 10

- | | |
|--------------------|------------|
| 1. Adjustable link | 2. Locknut |
|--------------------|------------|

Transport Height Adjustment

Transport height is adjusted to stabilize the mower in the up, locked position.

1. Raise attachment lift lever all the way to the latched position. Check if bumpers, on rear of mower draft bars contact under footrests.

- Adjust lift chain by turning trunnion on eyebolt in rear hole of tractor lift (Fig. 11). Turn trunnion clockwise to raise or counterclockwise to lower mower.

Note: Transport level stops are normally in the bottom of the slot, however they can be adjusted up for side-to-side level when extra weight from a grass catcher is on one side.

- To adjust side-to-side level, loosen the leveling bolts. (Fig. 11).
- Adjust the deck level and then tighten leveling bolts. (Fig. 11).

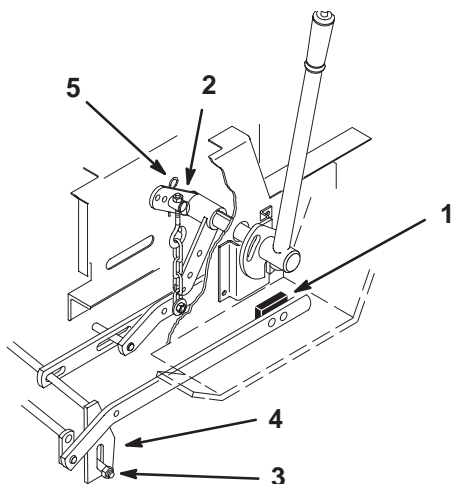

Figure 11

- | | |
|-------------------|-------------------------|
| 1. Bumper | 4. Transport level stop |
| 2. Trunnion | 5. Hairpin cotter |
| 3. Leveling bolts | |

Note: Determine the left and right sides of the machine from the normal operating position.

Operating the Power Take Off (PTO)

The power take off (PTO) switch engages and disengages power to the electric clutch.

The PTO light, in the Indicator Module, will be on when the ignition key is in run or lights position and the power take off (PTO) is engaged. When this light is on it is a reminder the starter will not crank and to turn the off PTO before getting off the tractor.

Engaging the Power Take Off (PTO)

- Move throttle to fast position.
- Pull the power take off (PTO) to the **on** position (Fig. 12).

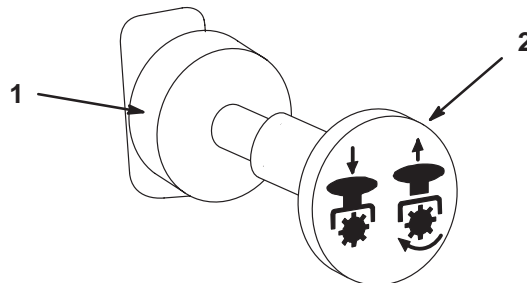

Figure 12

- PTO—Off
- PTO—On

Disengaging the Power Take Off (PTO)

- Push the power take off (PTO) to the **off** position (Fig. 12).

Operating the Attachment Lift Lever

The attachment lift lever (Fig. 13) is used to raise and lower various attachments.

Raising an Attachment

- Depress the clutch and brake pedals to stop the machine.
- Pull attachment lift lever rearward until latch locks. In this position the lift will hold the attachment in the up, or raised position.

Lowering an Attachment

- Depress the clutch and brake pedals to stop the machine.

2. Pull attachment lift lever rearward, to release lift pressure, and push the button on top to release the latch. Move lift lever forward to lower attachment.

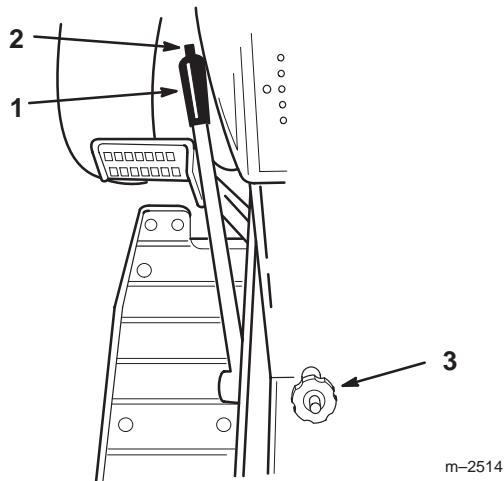

Figure 13

1. Lift lever
2. Button
3. Dial-A-Height

Operating the Attachment Power Lift

The attachment power lift (Fig. 14) is used to raise and lower attachments.

Raising Attachments

1. Start the engine, refer to; Starting and Stopping the Engine; in tractor Operator's Manual.
2. Pull the lift lever in the **up** direction to raise the attachment lift (Fig. 14). This will lift and hold the attachment in the up, or raised position.

Lowering Attachments

1. Start the engine, refer to; Starting and Stopping the Engine; in tractor Operator's Manual.
2. Push the lift lever in the **down** direction to lower the attachment lift (Fig. 14).

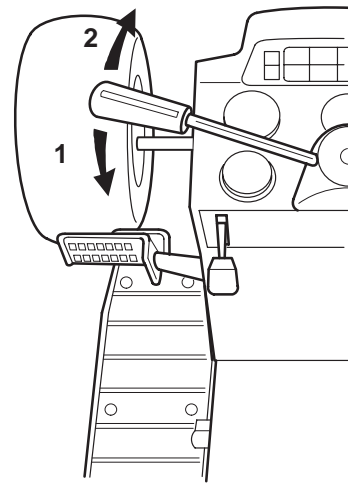

Figure 14

1. Lift lever UP
2. Lift lever DOWN

m-2454

Adjusting Height-of-Cut

The rear gauge wheels are adjusted in different hole location for 1-1/2 to 3-1/2 in. (4–9 cm) height-of-cut.

1. Pull height-of-cut lever out to disengage from quadrant. Adjust height-of-cut to the desired level. Release lever inward to lock into quadrant (Fig. 15).

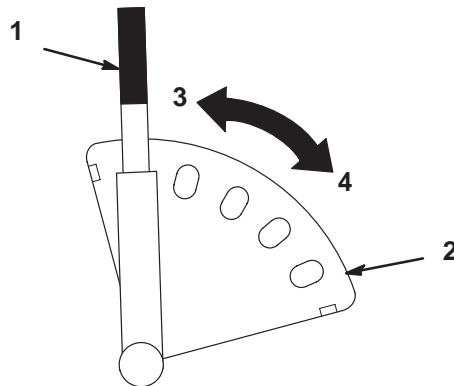

Figure 15

1. Height-of-cut lever
2. Quadrant
3. High
4. Low

m-2827

Removing the Mower

1. Park the machine on a level surface, disengage the power take off (PTO), set the parking brake, and turn the ignition key to off. Remove the key.
2. Remove the two knobs and belt cover from the tractor (Fig. 16).

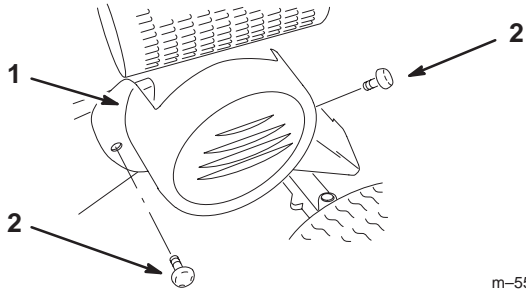

Figure 16

1. Belt cover
2. Knob

3. Turn knob on idler assembly clockwise to loosen belt. Remove belt from upper mower pulley (Fig. 17).

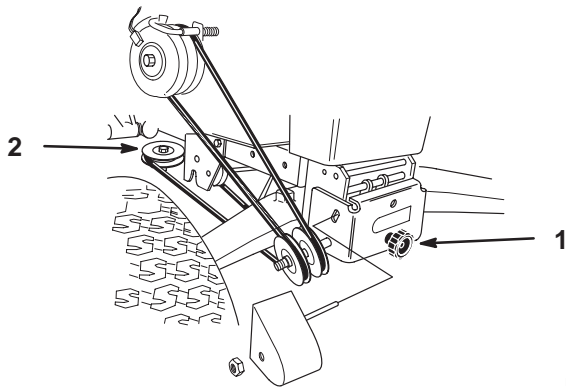

Figure 17

1. Knob
2. Upper mower pulley

4. Remove the belt from the clutch and deck. Refer to Replacing the PTO Belt on page 16.
5. Open front hitch and remove pulley assembly (Fig. 18).

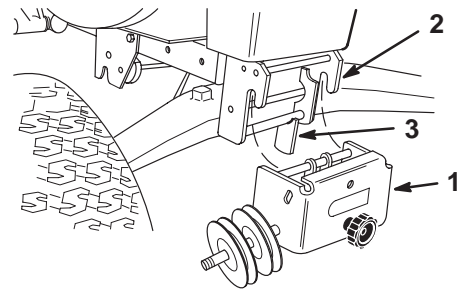

Figure 18

1. Pulley assembly
2. Front hitch
3. Latch

6. Raise attachment lift lever to the mounting position; refer to the tractor Operator's Manual.
7. Open mid-mount hitch lock handle. Lower mower with attachment lift and remove front mounting shaft (Fig. 19).

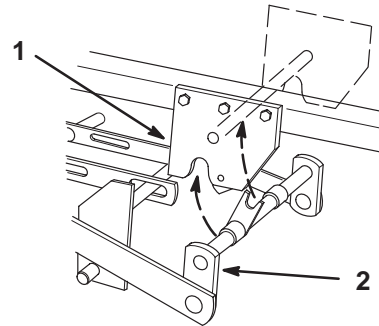

Figure 19

1. Mid-mount hitch
2. Front mounting shaft

8. Remove the hairpin cotter and washer from attachment lift pin from slot in center lever bar (Fig. 20).

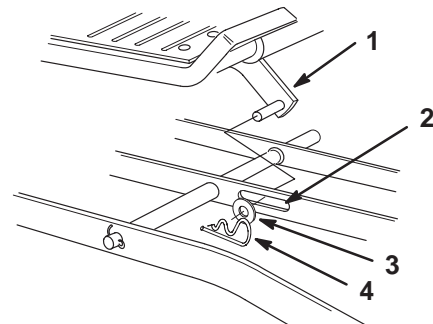

Figure 20

1. Attachment lift
2. Slot-center level bar
3. Washer
4. Hair pin cotter

9. Turn the front wheels fully to the left and raise attachment lift lever all the way to the latched position; refer to tractor Operator's Manual. Slide the mower out from under the chassis to the the right side.

Note: Save all hardware, washers and hairpin cotters for use when installing deck.

Tips for Mowing Grass

Fast Throttle Setting

For best mowing and maximum air circulation, operate the engine at fast. Air is required to thoroughly cut grass clippings, so do not set the height-of-cut so low, as to totally surround the mower by uncut grass. Always try to have one side of the mower free from uncut grass, which allows air to be drawn into the mower.

Cutting a Lawn for the First Time

Cut grass slightly longer than normal to ensure the cutting height of the mower does not scalp any uneven ground. However, the cutting height used in the past is generally the best one to use. When cutting grass longer than six inches tall, you may want to cut the lawn twice to ensure an acceptable quality-of-cut.

Cut 1/3 of the Grass Blade

It is best to cut only about 1/3 of the grass blade. Cutting more than that is not recommended, unless grass is sparse or it is late fall when grass grows more slowly.

Mowing Direction

Alternate mowing direction to keep the grass standing straight. This also helps disperse clippings which enhances decomposition and fertilization.

Mow at Correct Intervals

Normally, mow every 4 days. But remember, grass grows at different rates at different times. So to maintain the same cutting height, which is a good practice, mow more often in early spring. As the grass growth rate slows in mid summer, mow less frequently. If you cannot mow for an extended period, first mow at a high cutting height; then mow again 2 days later at a lower height setting.

Maintenance

Note: Determine the left and right sides of the machine from the normal operating position.

Ground Speed

To improve cut quality, use slower ground speed.

Avoid Cutting Too Low

If the cutting width of the mower is wider than the mower you previously used, raise the cutting height to ensure uneven turf is not cut too short.

Long Grass

If the grass is ever allowed to grow slightly longer than normal, or if it contains a high degree of moisture, raise the cutting height higher than usual and cut the grass at this setting. Then cut the grass again using the lower, normal setting.

When Stopping

If the machine's forward motion must be stopped while mowing, a clump of grass clippings may drop onto your lawn. To avoid this:

1. With the blade(s) engaged, move onto a previously cut area.
2. To disperse the clippings evenly, raise the mower one or two height-of-cut settings while driving forward with the blade(s) engaged.

Keep the Underside of the Mower Clean

Clean clippings and dirt from the underside of the mower after each use. If grass and dirt build up inside the mower, cutting quality will eventually become unsatisfactory.

Blade Maintenance

Maintain a sharp blade throughout the cutting season because a sharp blade cuts cleanly without tearing or shredding the grass blades. Tearing and shredding turns grass brown at the edges, which slows growth and increases the chance of disease. Every 30 days, check the cutter blade(s) for sharpness and file down any nicks.

Recommended Maintenance Schedule

Maintenance Service Interval	Maintenance Procedure
Each Use	<ul style="list-style-type: none"> • Mower Housing—clean
5 Hours	<ul style="list-style-type: none"> • Cutter Blade—check • Mower Housing—clean
25 Hours	<ul style="list-style-type: none"> • Tires—check pressure • Grease—Mower deck and wheels
At Storage	<ul style="list-style-type: none"> • Cutter Blade—check • Grease—Mower deck • Belts—check for wear/cracks • Mower Housing—clean • Chipped Surfaces—paint • Tires—check pressure

Important Refer to your engine operator’s manual for additional maintenance procedures.

Caution

If you leave the key in the ignition switch, someone could accidentally start the engine and seriously injure you or other bystanders.

Remove the key from the ignition and disconnect the wire from the spark plug(s) before you do any maintenance. Set the wire aside so that it does not accidentally contact the spark plug.

Servicing the Cutting Blades

To assure a superior quality of cut, keep the blade(s) sharp. For convenient sharpening and replacement, you may want to have an extra blade(s).

Danger

A worn or damaged blade can break, and a piece of the blade could be thrown into the operator’s or bystander’s area, resulting in serious personal injury or death.

- **Inspect the blade periodically for wear or damage.**
- **Replace a worn or damaged blade.**

Warning

A blade that is bent or damaged could break apart and could seriously injure or kill you or bystanders.

- **Always replace bent or damaged blade with a new blade.**
- **Never file or create sharp notches in the edges or surfaces of blade.**

Inspecting the Blade(s)

Inspect the blades every 5 hours.

1. Remove the mower; refer to Removing the Mower, page 11.
2. Carefully tip the mower over.

3. Inspect the cutting edges (Fig. 21). If the edges are not sharp or have nicks, remove the blade(s) and sharpen them; refer to Sharpening the Blade(s), page 14.
4. Inspect the blade(s), especially the curved area (Fig. 21). If you notice any damage, wear, or a slot forming in this area (Fig. 21), immediately install a new blade.

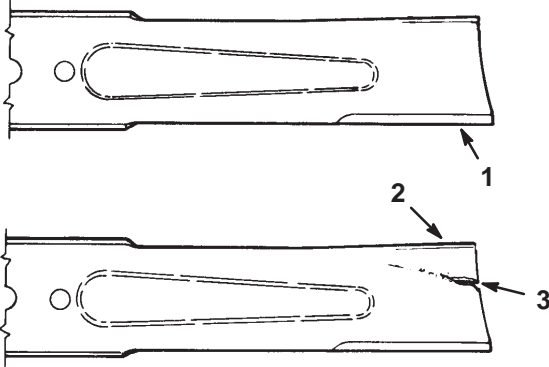

Figure 21

1. Cutting edge
2. Curved area
3. Wear/slot forming

151

Removing the Blades

1. Remove the mower; refer to Removing the Mower, page 11.
2. Carefully tip the mower over.
3. Remove the nut, flat washer, blade and washer (Fig. 22). A block of wood may be wedged between the blade and the mower to lock the blade when you are removing the bolt.
4. Inspect all parts. If damage is noticed, install new parts.

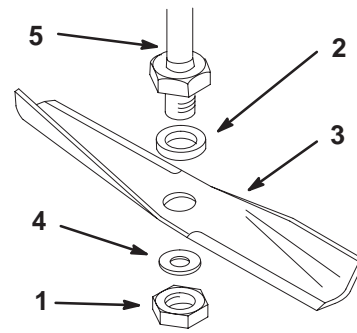

m-5617

Figure 22

1. Nut
2. Flat washer—thick
3. Blade
4. Washer—thin
5. Spindle

Sharpening the Blades

1. Use a file to sharpen the cutting edge at both ends of the blade (Fig. 23). Maintain the original angle. The blade retains its balance if the same amount of material is removed from both cutting edges.

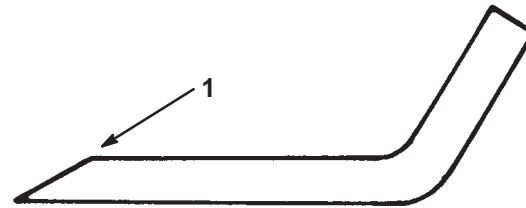

Figure 23

1. Sharpen at original angle
2. Check the balance of the blade by putting it on a blade balancer (Fig. 24). If the blade stays in a horizontal position, the blade is balanced and can be used. If the blade is not balanced, file some metal off the back side of the blade. Repeat this procedure until the blade is balanced.

3. Install the mower; refer to Installing the Mower, page 6.

Replacing the Power Take Off (PTO) Belt

Replacing the PTO Belt on 2001 and Newer Models

The following instructions are for 2001 and newer models only.

1. Remove the two knobs and belt cover from the tractor (Fig. 28).

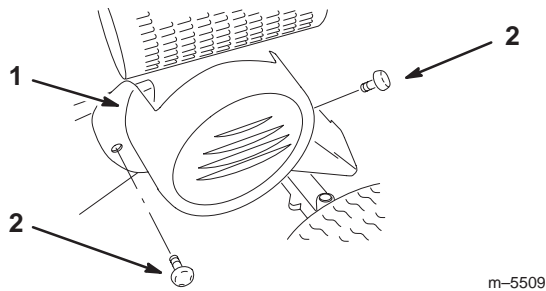

Figure 28

- | | |
|---------------|----------|
| 1. Belt cover | 2. Knobs |
|---------------|----------|

2. Turn knob on pulley assembly clockwise to loosen belt (Fig. 29).
3. Remove locknut and belt cover from idler assembly. Remove belt from top center mower pulley (Fig. 29).

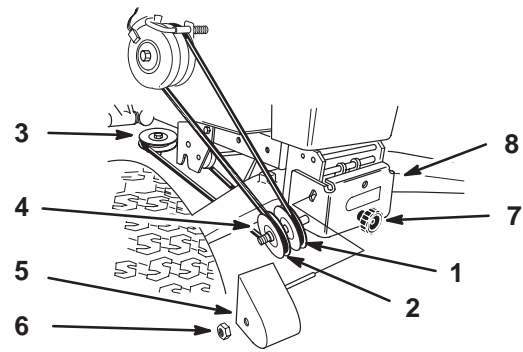

Figure 29

m-5508

- | | |
|----------------------------|--------------------|
| 1. V pulley | 5. Belt cover |
| 2. Flat pulley | 6. Locknut |
| 3. Top center mower pulley | 7. Knob |
| 4. Spacer | 8. Pulley assembly |

4. Unplug the clutch connector (Fig. 30).
5. Pull the PTO stop out of the clutch (Fig. 30).
6. Rotate the clutch to allow space between the belt guide and the clutch. This will allow the belt to be installed onto the pulley (Fig. 30).
7. Replace the belt and install new belt into the inside pulley (Fig. 30).

Important Install belt in the inside pulley groove for the mower.

8. Install the PTO stop back into the clutch (Fig. 30).
9. Install the clutch connector (Fig. 30).

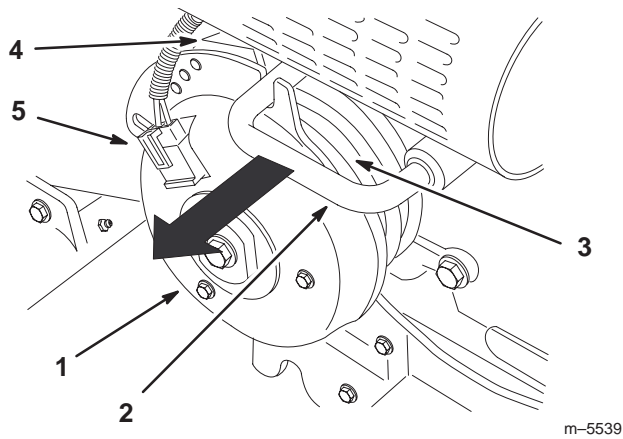

Figure 30

- | | |
|-----------------------|---------------------|
| 1. PTO clutch | 4. Belt guide |
| 2. PTO stop | 5. Clutch connector |
| 3. Inside belt groove | |

10. Route belt around V and flat pulleys and loop over top center mower pulley (Fig. 31).

11. Check that spacer is on the shaft and install the belt cover with rod in hole. Secure with locknut (Fig. 31).

12. Turn knob counterclockwise to tighten belt (Fig. 31). Tighten until there is 1 in. (26 mm) belt movement between engine clutch and idler pulley when slight pressure is applied to the belt.

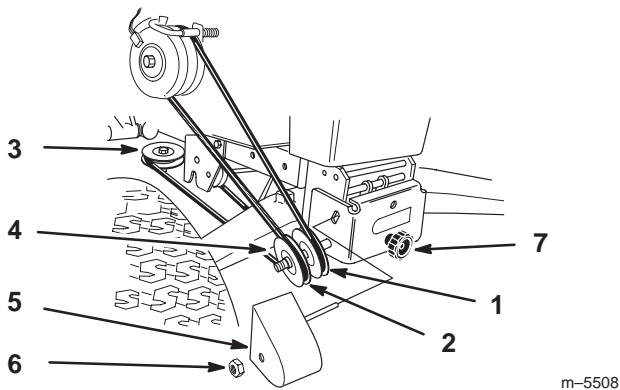

Figure 31

- | | |
|---------------------|---------------|
| 1. V pulley | 5. Belt cover |
| 2. Flat pulley | 6. Locknut |
| 3. Top mower pulley | 7. Knob |
| 4. Spacer | |

13. Install belt cover (Fig. 28).

Replacing the PTO Belt on 2000 and Older Models

The following instructions are for 2000 and Older Models only.

1. Remove the two knobs and belt cover from the tractor (Fig. 32).

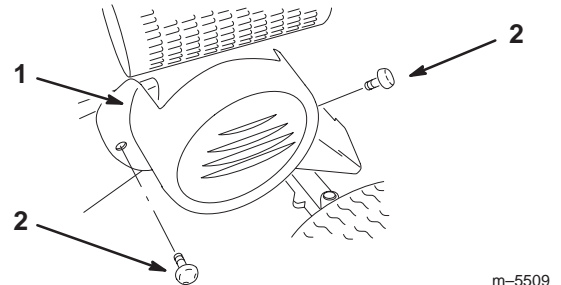

Figure 32

- | | |
|---------------|---------|
| 1. Belt cover | 2. Knob |
|---------------|---------|

2. Turn knob on pulley assembly clockwise to loosen belt (Fig. 33).

3. Remove locknut and belt cover from idler assembly. Remove belt from the top center mower pulley (Fig. 33).

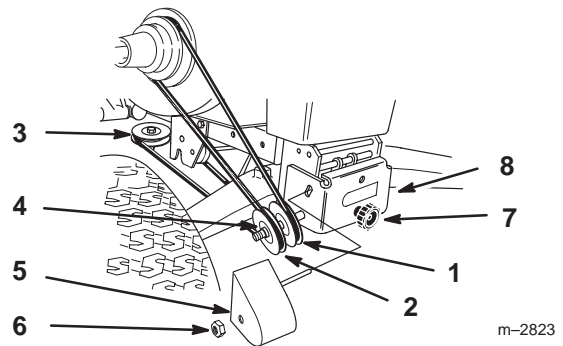

Figure 33

- | | |
|----------------------------|--------------------|
| 1. V pulley | 5. Belt cover |
| 2. Flat pulley | 6. Locknut |
| 3. Top center mower pulley | 7. Knob |
| 4. Spacer | 8. Pulley assembly |

4. Unlatch and remove locking clevis pin that secures yoke assembly to clutch shaft. Pivot yoke out and forward to remove from clutch shaft and engagement plate (Fig. 34).

5. Replace belt in inside pulley groove (Fig. 34).

- Assemble yoke and engagement plate and attach locking clevis pin, trunnion and hairpin cotters to secure (Fig. 34).

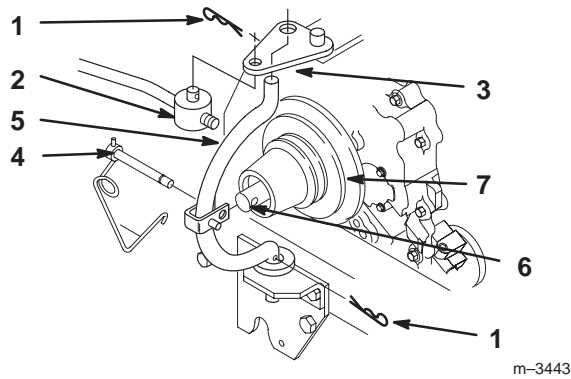

Figure 34

- | | |
|-----------------------|------------------|
| 1. Hairpin cotter | 5. Yoke |
| 2. Trunnion | 6. Clutch shaft |
| 3. Engagement plate | 7. Inside groove |
| 4. Locking clevis pin | |
-
- Route belt around V and flat pulleys and loop over upper mower pulley (Fig. 35).
 - Check that spacer is on the shaft and install the belt cover with rod in hole. Secure with a locknut (Fig. 35).
 - Turn knob counterclockwise to tighten belt (Fig. 35). Tighten until there is 1 in. (26 mm) belt movement between engine clutch and idler pulley when slight pressure is applied to the belt.

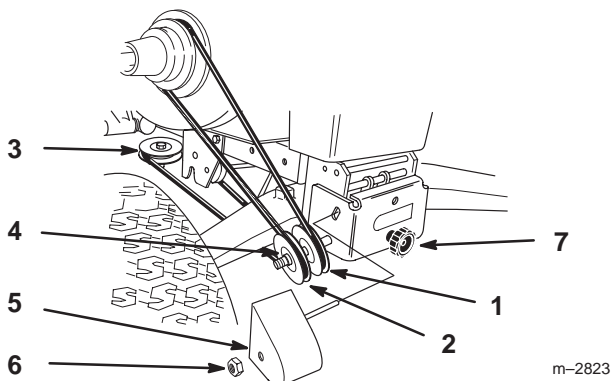

Figure 35

- | | |
|-----------------------|---------------|
| 1. V pulley | 5. Belt cover |
| 2. Flat pulley | 6. Locknut |
| 3. Upper mower pulley | 7. Knob |
| 4. Spacer | |

- Install belt cover (Fig. 32).

Cleaning and Storage

- Clean dirt and chaff from the outside of the engine's cylinder head fins and blower housing. Also remove grass clippings, dirt, and grime from the external parts of the entire machine, especially the engine, shrouding, and the top of the mower.

Important You can wash the machine with mild detergent and water. Do not pressure wash the machine. Avoid excessive use of water, especially near the control panel, lights, engine, and the battery.

- Scrape heavy buildup of grass and dirt from the underside of the mower. Then wash the mower with a garden hose.
- Check the condition of the blade(s); refer to Servicing the Cutting Blades, page 13.
- Check the condition of the blade drive belt.
- Grease the mower deck; refer to Greasing and Lubrication, page 15.
- Check and tighten all bolts, nuts, and screws. Repair or replace any part that is damaged or defective.
- Paint all scratched or bare metal surfaces. Paint is available from your Authorized Service Dealer.
- Store the machine in a clean, dry garage or storage area. Remove the key from the ignition switch and keep it in a memorable place. Cover the machine to protect it and keep it clean.

Troubleshooting

Problem	Possible Causes	Corrective Action
Abnormal vibration.	<ol style="list-style-type: none"> 1. Cutting blade(s) is bent or unbalanced. 2. Blade mounting bolt is loose. 3. Engine mounting bolts are loose. 4. Loose engine pulley, idler pulley, or blade pulley. 5. Engine pulley is damaged. 	<ol style="list-style-type: none"> 1. Install new cutting blade(s). 2. Tighten blade mounting bolt. 3. Tighten engine mounting bolts. 4. Tighten the appropriate pulley. 5. Contact Authorized Service Dealer.
Blade(s) does not rotate.	<ol style="list-style-type: none"> 1. Blade drive belt is worn, loose or broken. 2. Blade drive belt is off pulley. 3. PTO belt is worn, loose or broken. 	<ol style="list-style-type: none"> 1. Install new blade drive belt. 2. Install blade drive belt and check idler pulley and belt guides for correct position. 3. Install new PTO belt.
Uneven cutting height.	<ol style="list-style-type: none"> 1. Tire pressure is incorrect. 2. Mower is not level. 3. Underside of mower is dirty. 	<ol style="list-style-type: none"> 1. Set tire pressure. 2. Level mower from side-to-side and front-to-rear. 3. Clean the underside of the mower.

