



Z147

Z-Master[®] with 44" Side Discharge Mower

Model No. 74176—220000263 and Up

Parts Catalog

Ordering Replacement Parts

To order replacement parts, please supply: the part number, the quantity, and the description of each part desired.

Understanding Reference Numbers

Each identified part in an illustration has a reference number. The reference number for a part also appears in the parts list, along with other information about the part.

This catalog uses two special reference number formats, one to indicate parts in a service assembly and another to indicate the quantity of a given part in an illustration.

Service Assembly Reference Numbers

Parts in service assemblies have reference numbers in the form **a:b**. The **a** represents the reference number of the entire service assembly and the **b** represents a sequential number unique to each part within the service assembly.

For example, a wheel assembly might be identified by reference number **6**, the tire by **6:1**, the valve by **6:2**, and the wheel by **6:3**. When you order the assembly identified by reference number **6**, you receive all parts identified by reference numbers **6:1**, **6:2**, and **6:3**. However, you may also order any part individually.

Reference numbers of this type appear in illustrations and in part lists.

Reference Numbers Indicating Quantity

In an illustration, if a reference number indicates more than one part, the reference number has the form **nX y**. The **n** represents the quantity of the part, the **X** is the multiplication symbol, and the **y** represents the reference number.

For example, in an illustration, the reference number **2X 37** means that two of the parts identified by reference number **37** are indicated.

Contents

Description	Page
Front Frame Assembly	4
Height of Cut Assembly	6
Main Frame Assembly	7
Fuel System Assembly	8
Parking Brake System Assembly	9
Motion Control System Assembly	10
Hydraulic System Assembly	11
Pump, Idler and Belt Assembly	13
Engine and Clutch Assembly	14
Deck Assembly	15
Deck Spindle Assembly	16
Idler, Pulley/Lift Strut, Chain Assembly	17
Electrical System Assembly	18
Electrical Schematic	19
Cylinder/Crankcase Assembly	
Kawasaki FH500V-ES10	20
Valve/Camshaft Assembly	
Kawasaki FH500V-ES10	22

Description	Page
Piston/Crankshaft Assembly	
Kawasaki FH500V-ES10	24
Lubrication-Equipment Assembly	
Kawasaki FH500V-ES10	25
Cooling-Equipment Assembly	
Kawasaki FH500V-ES10	26
Electric-Equipment Assembly	
Kawasaki FH500V-ES10	28
Control-Equipment Assembly	
Kawasaki FH500V-ES10	30
Carburetor Assembly	
Kawasaki FH500V-ES10	32
Air-Filter/Muffler Assembly	
Kawasaki FH500V-ES10	34
Fuel-Tank/Fuel-Valve Assembly	
Kawasaki FH500V-ES10	35
Starter/Decal	
Kawasaki FH500V-ES10	36

Accessories

Description	Model / Part No.
Recycler Kit	59220
Bahaia Mulching Kit	59226
Striping Kit	30121
High Suspension Seat	99-8522

Description	Model / Part No.
Hitch Kit	99-8924
Atomic Blade ASM (Single Blade)	104-1300
Z-Stand Kit	105-1621
Mulching Blade	55-4940-03

Part Description Abbreviations

Part descriptions in this catalog may include the following abbreviations.

Abbreviation	Meaning	Abbreviation	Meaning
AR	as required	INC	incorporated
ASM	assembly	LH	left hand
CARR	carriage	NI	nylon insert
DEG	degrees	PPH	Phillips pan head
FH	flat head	PTH	Phillips truss head
GA	gauge	PTO	power take off
HF	hex flange	RH	right hand
HH	hex head	SFH	slotted fillister head
HHF	hex head flange	SHH	slotted hex head
HLH	hex lag head	SQH	square head
HJ	hex jam	SHWH	slotted hex washer head
HOC	height-of-cut	SPH	slotted pan head
HS	hex socket	SRH	slotted round head
HSBH	hex socket button head	STD	standard
HSFH	hex socket flat head	TAP	self tapping
HSH	hex socket head	TTH	Torx truss head
HWH	hex washer head	WH	wing head
HWHTF	hex washer head thread forming		

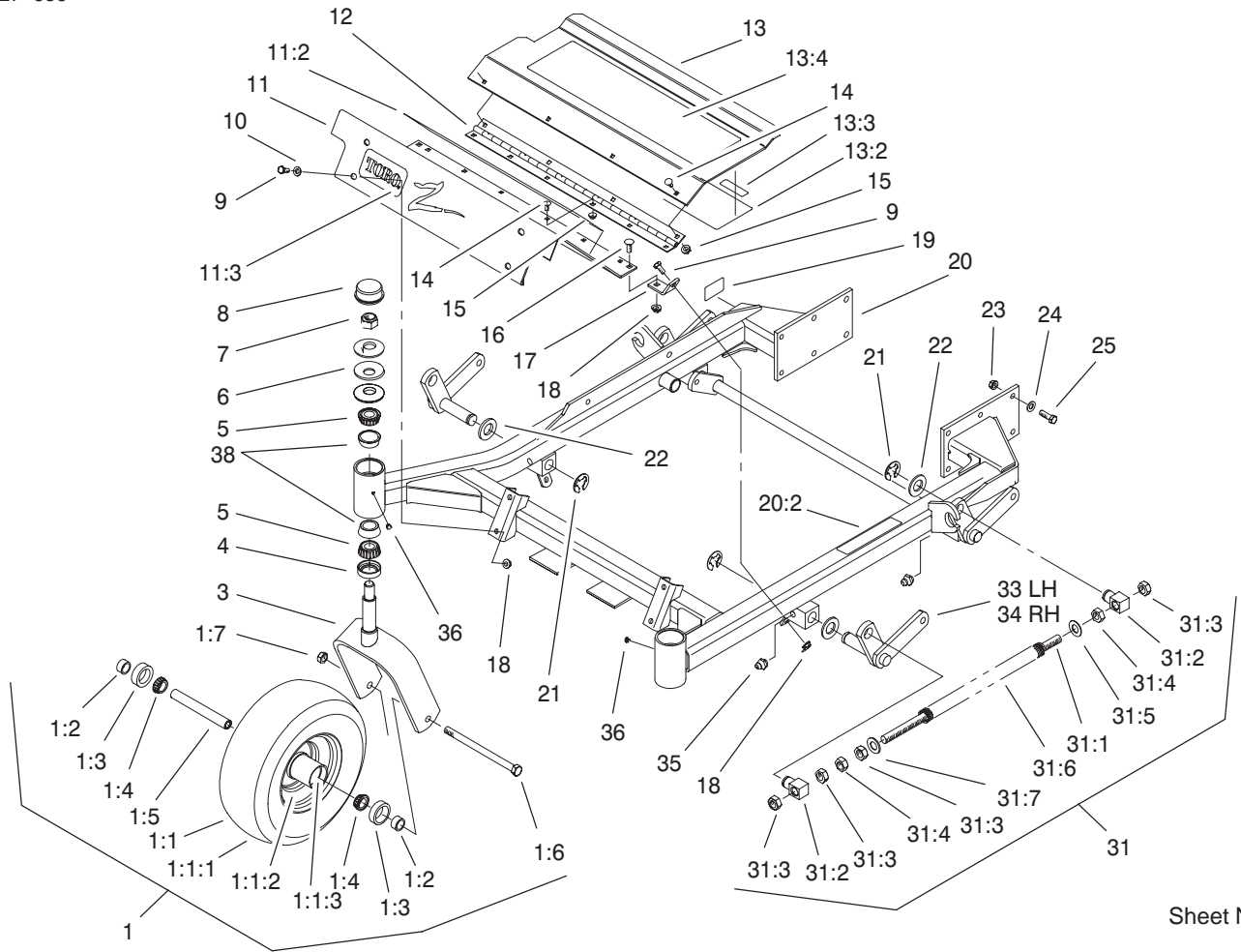

Sheet No.:2

Front Frame Assembly

Ref. No.	Part No.	Qty.	Description
1	1-634662	2	Caster Wheel ASM
1:1	1-633582	1	Wheel & Tire ASM
1:1:1	1-633002	1	Tire
1:1:2	1-633583	1	Wheel
1:1:3	1-633584	2	Bearing-Cup
1:2	1-633581	2	Spacer-Bearing
1:3	1-633580	2	Seal-Bearing
1:4	1-633585	2	Bearing-Cone, Taper
1:5	1-633579	1	Spacer-Caster, Front
1:6	325-36	1	Screw-HH
1:7	3296-45	1	Nut-Lock, NI
3	1-632511-01	2	Caster
4	1-543511	2	Seal-Grease
5	254-94	4	Bearing-Cone, Taper
6	1-633508	6	Washer-Bellville
7	3296-51	2	Nut-Lock, NI
8	1-543513	2	Cap-Grease
9	322-3	6	Screw-HH
10	3256-23	4	Washer-Flat
11	99-3940	1	Floorpan-Front
11:2	1-633553	1	Pad-Antiskid
11:3	1-633737	1	Decal-Z-Master
12	1-653049	1	Hinge-Floorpan
13	99-3930	1	Footrest ASM
13:2	99-3924	1	Decal-Service
13:3	98-5954	1	Decal-Missing, Cover

Ref. No.	Part No.	Qty.	Description
13:4	1-633553	1	Pad-Antiskid
14	3229-10	10	Screw-CARR
15	32128-33	10	Nut-HF
16	3230-1	2	Screw-CARR
17	99-3870-01	2	Bracket-Floorpan
18	32128-20	8	Nut-HF
19	105-2625	1	Decal-Safety STD
20	99-3931	1	Front Frame ASM
20:2	1-633818	1	Decal-Warning
21	32151-103	6	Ring-Snap
22	3256-29	6	Washer-Flat
23	3290-357	12	Nut-HHF
24	98-5975	12	Washer-Bellville
25	323-7	12	Screw-HH
31	103-1987	2	Front Spring ASM
31:1	1-653011	1	Rod-Lift, Deck
31:2	1-633441	2	Swivel-Deck Mount, Rear
31:3	3217-11	4	Nut-Hex
31:4	3218-6	2	Nut-Jam
31:5	1-805517	1	Washer
31:6	1-653009	1	Spring-Compression
31:7	3256-27	1	Washer-Flat
33	99-3871-01	1	LH Lift Arm ASM
34	99-3872-01	1	RH Lift Arm ASM
35	302-19	4	Fitting-Grease

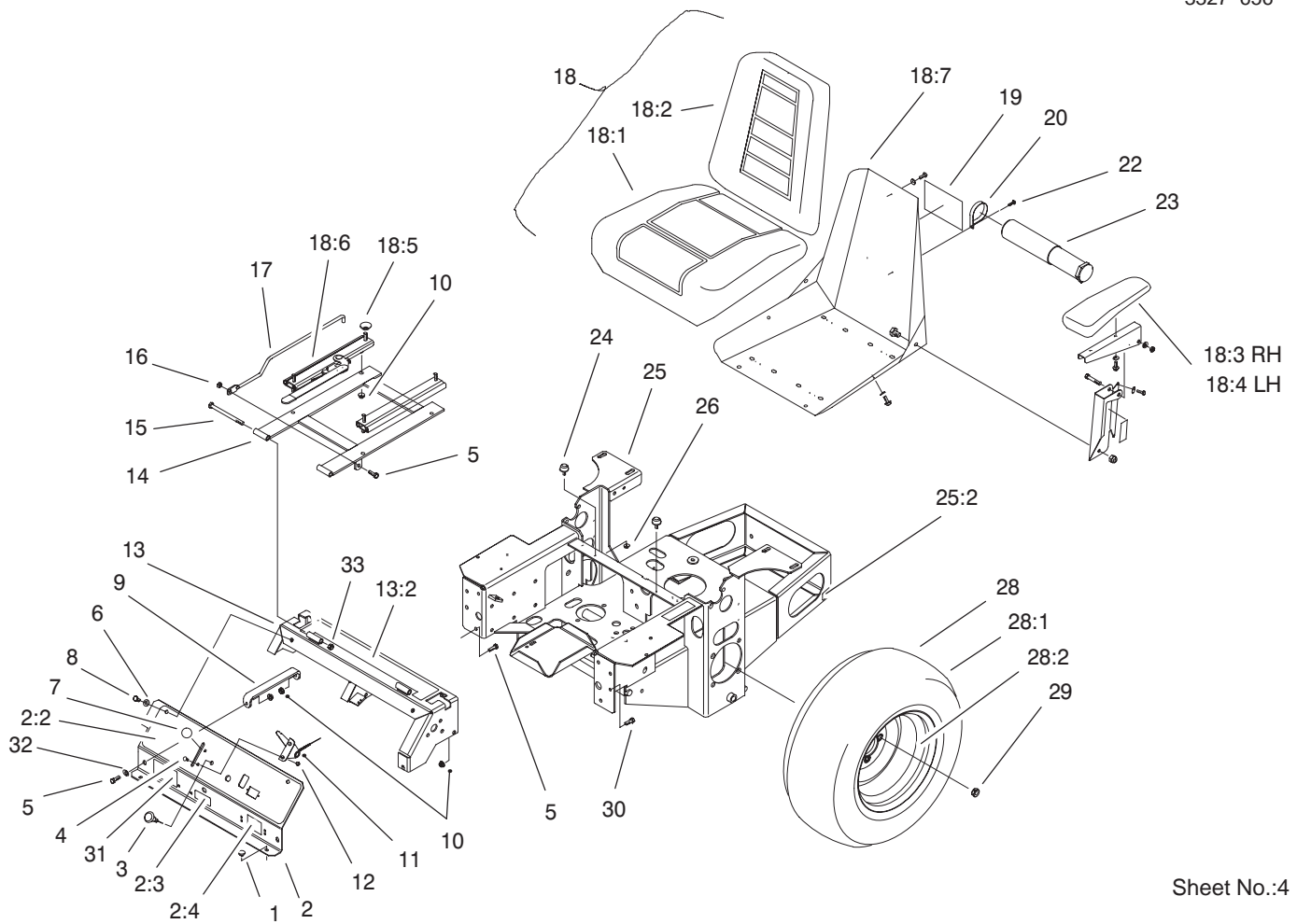

Sheet No.:4

Main Frame Assembly

Ref. No.	Part No.	Qty.	Description
1	1-513658	2	Bumper-Catcher, Grass
2	99-3932	1	Control Panel ASM
2:2	99-3942	1	Decal-Panel, Control
2:3	103-0262	1	Decal-Valve, Fuel
2:4	98-4387	1	Decal-Protection, Ear
3	1-603336	1	Control-Choke
4	1-807513	2	Bolt-CARR
5	322-5	3	Screw-HH
6	3256-23	2	Washer-Flat
7	1-513592	1	Knob-Ball, Red
8	322-3	3	Screw-HH
9	1-653089-03	1	Bracket
10	32128-20	12	Nut-HF
11	1-633696	1	Cable-Throttle
12	3296-2	2	Nut-Lock
13	105-6123	1	Console ASM
13:2	103-1997	1	Decal-Top Console
14	1-632187-03	1	Frame-Seat
15	323-39	2	Screw-HH
16	3296-29	1	Nut-Lock, NI
17	103-1731	1	Rod-Retainer, Seat
18	1-633705	1	Seat W/Tracks
18:1	103-0290	1	Cushion-Bottom, Seat
18:2	104-7754	1	Cushion-Back, Seat
18:3	1-633710	1	Cushion-Armrest, RH

Ref. No.	Part No.	Qty.	Description
18:4	1-633711	1	Cushion-Armrest, LH
18:5	1-543401	4	Spacer-Track
18:6	1-643255	1	Grp-Track, Seat
18:7	1-633859	1	Frame-Seat
19	99-4693	1	Decal-Toro
20	2412-120	2	R-Clamp
22	32104-76	2	Screw
23	74-0720	1	Tube-Manual
24	1-523420	2	Bumper
25	105-6121	1	Main Frame ASM
25:2	65-2690	2	Decal-Surface, Hot
26	3296-42	2	Nut-Lock, NI
28	1-653010	2	Wheel & Tire ASM
28:1	1-653160	1	Tire
28:2	1-653158	1	Wheel
29	242-50	8	Nut-Lug
30	322-2	6	Screw-HH
31	99-4603	1	Decal-Z147
32	3256-3	2	Washer-Flat
33	3296-39	2	Nut-Lock, NI

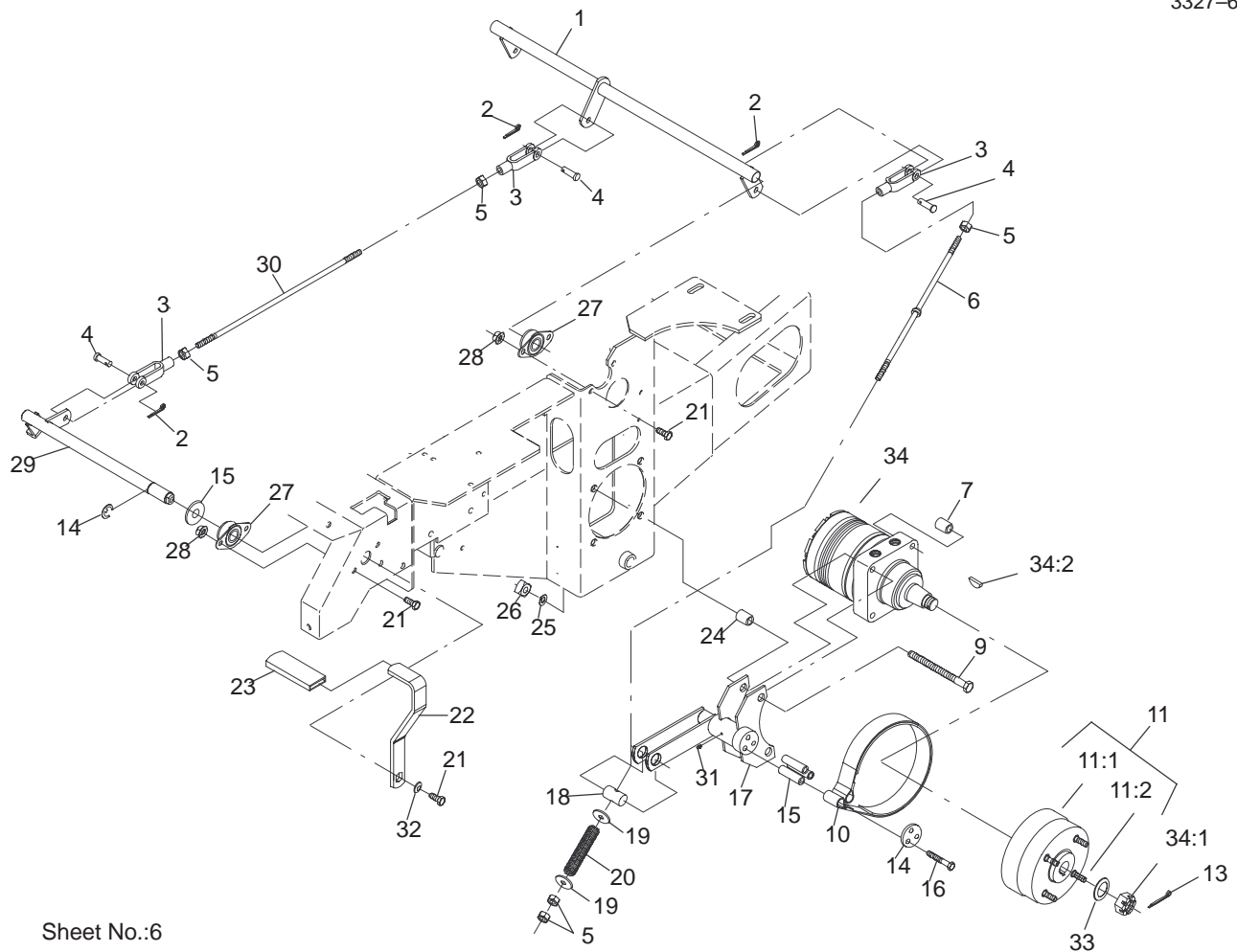

Sheet No.:6

Parking Brake System Assembly

Ref. No.	Part No.	Qty.	Description	Ref. No.	Part No.	Qty.	Description
1	1-652073-03	1	Crank-Brake, Park	27	1-633102	4	Bearing-Flange, Side
2	3272-10	4	Pin-Cotter	28	3290-357	8	Nut-HHF
3	1-633131	4	Yoke-Linkage, Brake	29	1-652085	1	Shaft-Brake, Parking
4	1-808285	4	Pin-Clevis	30	1-653061	1	Linkage-Handle, Brake
5	3219-3	8	Nut-HH	31	1481	2	Fitting-Grease
6	103-0356	2	Rod-Brake	32	98-5975	2	Washer-Belleville
7	1-653068	4	Spacer-Wheel	33	1-523157	2	Washer-Spacer
9	325-13	8	Screw-HH	34	1-523328	2	Motor-Wheel
10	103-0355	2	Band-Brake	34:1	1-809036	1	Nut-HH
11	103-0590	2	Hub-Wheel W/Studs	34:2	3257-42	1	Key-Woodruff
11:1	103-0589	1	Hub-Wheel	*34:99	1-000099	1	Kit-Seal
11:2	1-633926	4	Stud-Wheel	*34:99	1-000139	1	Kit-Bearing
13	1-806800	2	Pin-Cotter	35	32151-48	1	E-Ring
14	103-0374	2	Retainer-Band, Brake	36	3256-28	1	Washer-Flat
15	103-0384	6	Spacer				
16	322-9	6	Screw-HH				
17	103-0352-03	2	Bracket-Brake				
18	1-633144	2	Pin-Trunion				
19	3256-4	4	Washer-Flat				
20	1-633454	2	Spring-Brake				
21	323-4	9	Screw-HH				
22	1-653074-03	1	Handle-Brake, Park				
23	1-633268	1	Grip-Lever, Brake				
24	1-653069	4	Spacer-Wheel				
25	3253-7	8	Washer-Lock				
26	103-0131	8	Nut-Square				

* Not illustrated

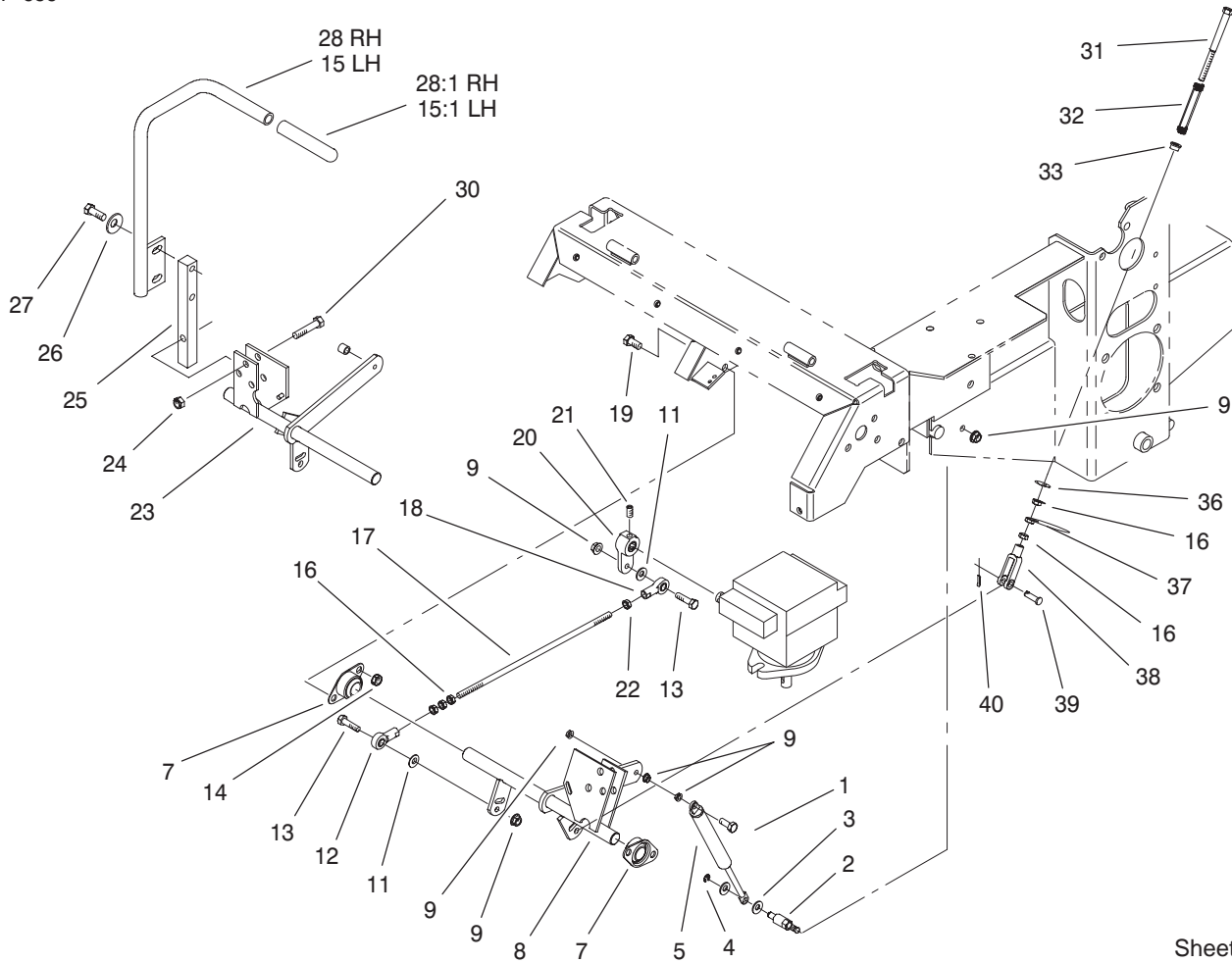

Sheet No.:7

Motion Control System Assembly

Ref. No.	Part No.	Qty.	Description
1	1-403180	2	Screw-HH
2	1-653316	2	Pin-Damper
3	3256-23	4	Washer-Flat
4	32120-35	2	E-Ring
5	1-523027	2	Damper-Control
7	1-633102	4	Bearing-Flange, Side
8	103-2199	1	LH Motion Control ASM
9	32128-20	12	Nut-HF
11	3256-3	4	Washer-Flat
12	1-543017	2	Balljoint-RH
13	322-6	4	Screw-HH
14	3290-357	8	Nut-HHF
15	103-0631	1	LH Lever ASM
15:1	1-633257	1	Grip-Control, Motion
16	3219-2	10	Nut-Hex
17	1-653046	2	Linkage-Pump/Lever
18	1-633152	2	Balljoint-Thread, LH
19	323-4	8	Screw-HH
20	1-653092	2	Arm-Control, Pump
21	1-803022	2	Screw
22	1-804524	2	Nut
23	103-2200	1	RH Motion Control ASM
24	3296-39	6	Nut-Lock, NI
25	103-0407	2	Arm-Shaft, Control

Ref. No.	Part No.	Qty.	Description
26	98-5975	4	Washer-Belleville
27	323-6	4	Screw-HH
28	103-0632	1	RH Lever ASM
28:1	1-633257	1	Grip-Control, Motion
30	323-9	6	Screw-HH
31	1-603737	2	Bolt-Return, Neutral
32	1-603807	2	Spring-Return, Neutral
33	1-603735	2	Bushing-Flanged
36	3256-2	2	Washer-Flat
37	3220-2	2	Nut
38	1-303105	2	Yoke-Adjustable
39	1-808280	2	Pin-Clevis
40	3272-5	2	Pin-Cotter

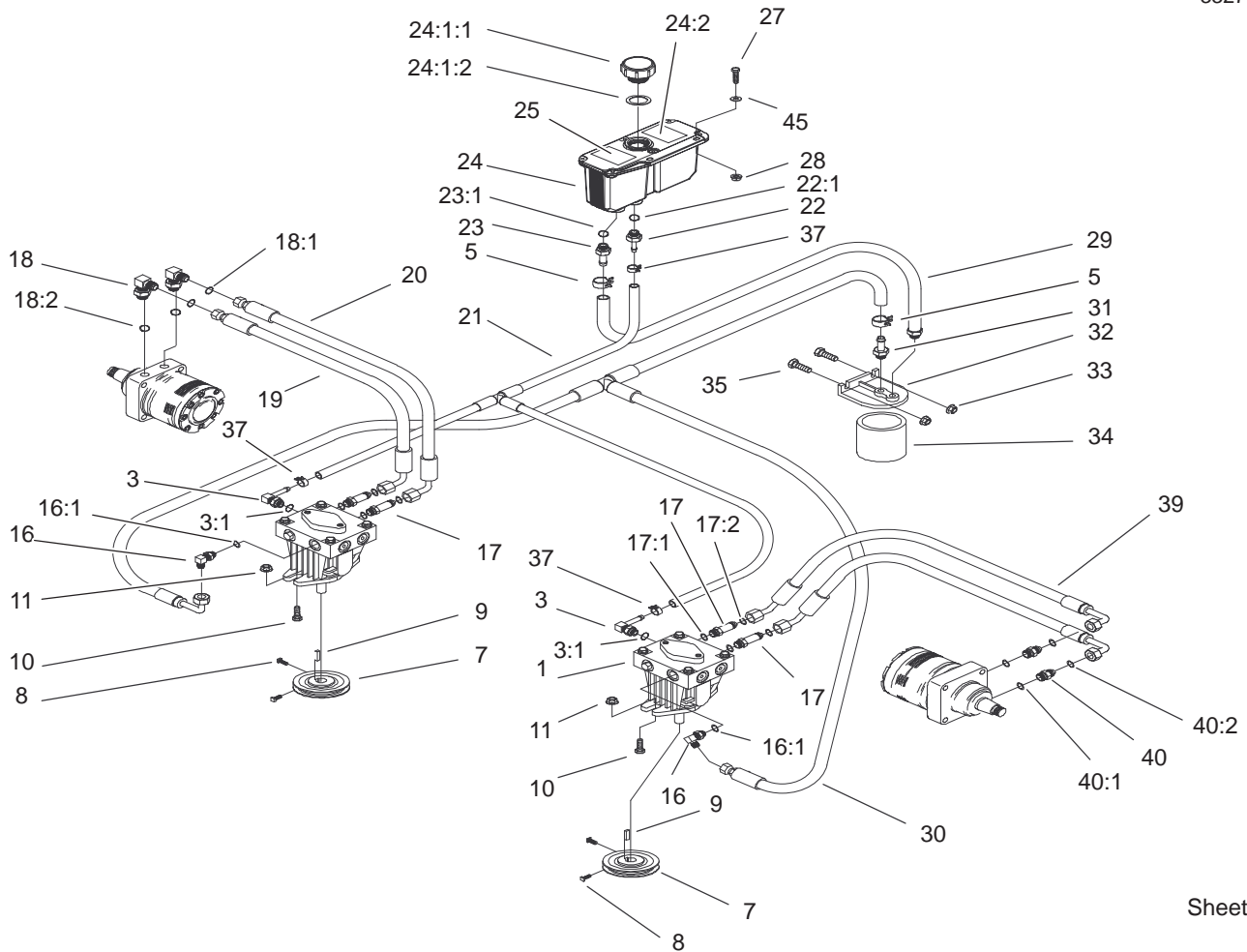

Sheet No.:8

Hydraulic System Assembly

Ref. No.	Part No.	Qty.	Description
1	103-1942	2	Pump-Hydraulic
*1:1	105-6184	1	Kit - Overhaul, Seal
*1:2	105-6185	1	Plate - Valve
*1:8	103-2664	1	Kit,Input Shaft 10a
*1:9	103-2665	1	Kit,Thrust Bearing 10a
*1:10	103-2666	1	Kit,Cylinder Block 10a
3	103-1799	2	Elbow-90°
3:1	237-42	1	O-Ring
5	103-1988	2	Clamp-Hose
7	1-653156	2	Sheave
8	1-803050	4	Screw-Set
9	1-807272	2	Key-Machine
10	323-7	4	Screw-HH
11	3290-357	4	Nut-HHF
16	103-1802	2	Elbow-90°
16:1	237-42	1	O-Ring
17	103-1940	4	Adapter,Straight
17:1	237-79	1	O-Ring
17:2	1-603992	1	O-Ring
18	1-633605	2	Fitting-Connector
18:1	1-603992	1	O-Ring
18:2	237-80	1	O-Ring
19	1-653186	1	Hose,Front
20	1-653187	1	Hose,RH Rear
21	103-1800	1	HYD Hose ASM
22	103-1801	1	Adapter-Straight

Ref. No.	Part No.	Qty.	Description
22:1	237-42	1	O-Ring
23	103-1912	1	Adapter,Straight
23:1	237-42	1	O-Ring
24	103-1947	1	HYD Reservoir ASM
☆24:1		1	HYD Reservoir ASM
24:1:1	103-1948	1	Cap,Hydraulic Reservoir
24:1:2	103-1949	1	Gasket-Cap
24:2	1-523552	1	Decal-Tank, Hydraulic
25	103-2644	1	Decal-System, Exhaust
27	321-14	2	Screw-HH
28	32128-33	2	Nut-HF
29	103-1805	1	HYD Hose ASM
30	103-1803	1	HYD Hose ASM
31	103-1804	1	Adapter-Straight
32	1-603720	1	Head-Filter
33	32128-20	2	Nut-HF
34	1-633750	1	Filter-HYD
34	1-633752	1	Filter-HYD, Winter
35	322-5	2	Screw-HH
37	103-1716	3	Clamp-Hose
39	103-1680	2	Hose-LH
40	1-603991	2	Fitting-Straight
40:1	237-80	1	O-Ring
40:2	1-603992	1	O-Ring

* Not illustrated

☆ Not serviced separately

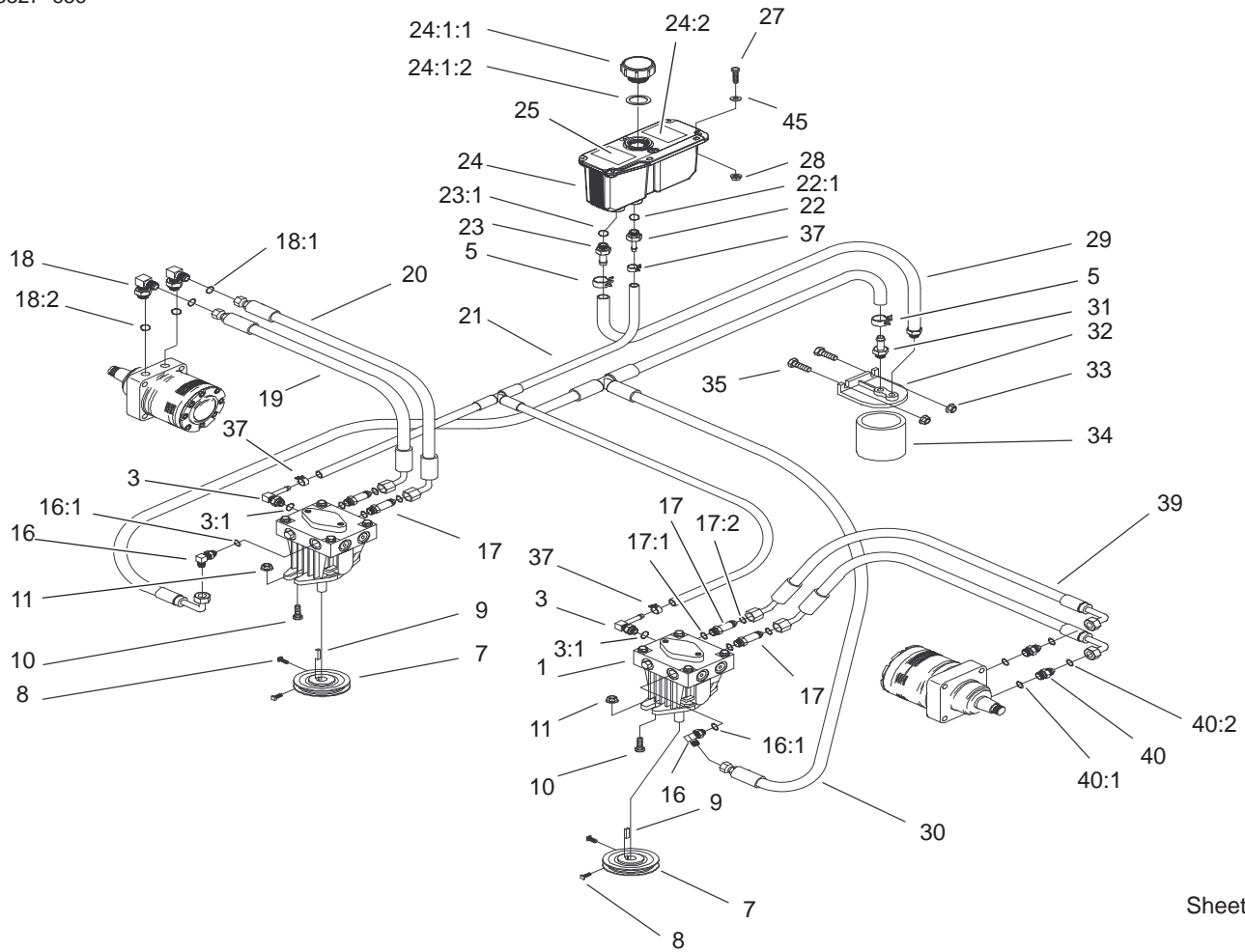

Sheet No.:8

Hydraulic System Assembly (Continued)

Ref. No.	Part No.	Qty.	Description
45	3256-22	2	Washer-Flat

Ref. No.	Part No.	Qty.	Description
----------	----------	------	-------------



Sheet No.:10

Engine and Clutch Assembly

Ref. No.	Part No.	Qty.	Description
1	3212-12	1	Screw-HH
2	1-603610	2	Washer-Spring
3	1-653048	1	Clutch-Stop
4	1-653035	1	Sheave W/Hub
5	1-807259	1	Key
6	103-2308	1	Spacer-Crankshaft
7	322-9	4	Screw-HH
8	32128-20	27	Nut-HF
9	322-3	21	Screw-HH
10	3296-29	4	Nut-Lock, NI
11	1-652146-03	1	Strap-Guard, Engine
12	1-653095-03	1	Shield-Engine
13	103-2751-03	1	Strap,Eng Guard LH Exhaust
14	103-1324	1	Muffler
15	103-2560-03	1	Shield-Heat
16	322-2	4	Screw-HH
17	103-1966	1	Adapter
18	103-1965	1	Valve-Drain, Oil
19	1-633630	2	Grommet-Brake
20	1-633545	2	Spacer-Grommet
21	1-613235	4	Washer
22	322-6	1	Screw-HH
23	1-303335	2	Tie-Plastic
24	1-523406	1	Bushing-Mount, Seat
25	1-633543-03	1	Strap-Clutch, Brake

Ref. No.	Part No.	Qty.	Description
26	322-22	1	Screw-HH
27	3256-3	3	Washer-Flat
28	1-653196	1	Bracket-Support, Muffler
30	1-653565-03	1	Shield,Heat
31	3230-1	3	Screw-CARR
32	3256-23	3	Washer-Flat
33	3296-29	3	Nut-Lock, NI
☆36		1	Engine-Kawasaki, Fh500v-Es10
37	1-303334	2	Washer-Spring
38	103-2599	1	Wld,Tailpipe
39	103-2630	1	Clamp,1.25"
40	103-2631	1	Clamp,1.125"
41	103-2564-03	1	RH Exhaust Guard ASM
42	103-2566-03	1	LH Exhaust Guard ASM

☆ Not serviced separately

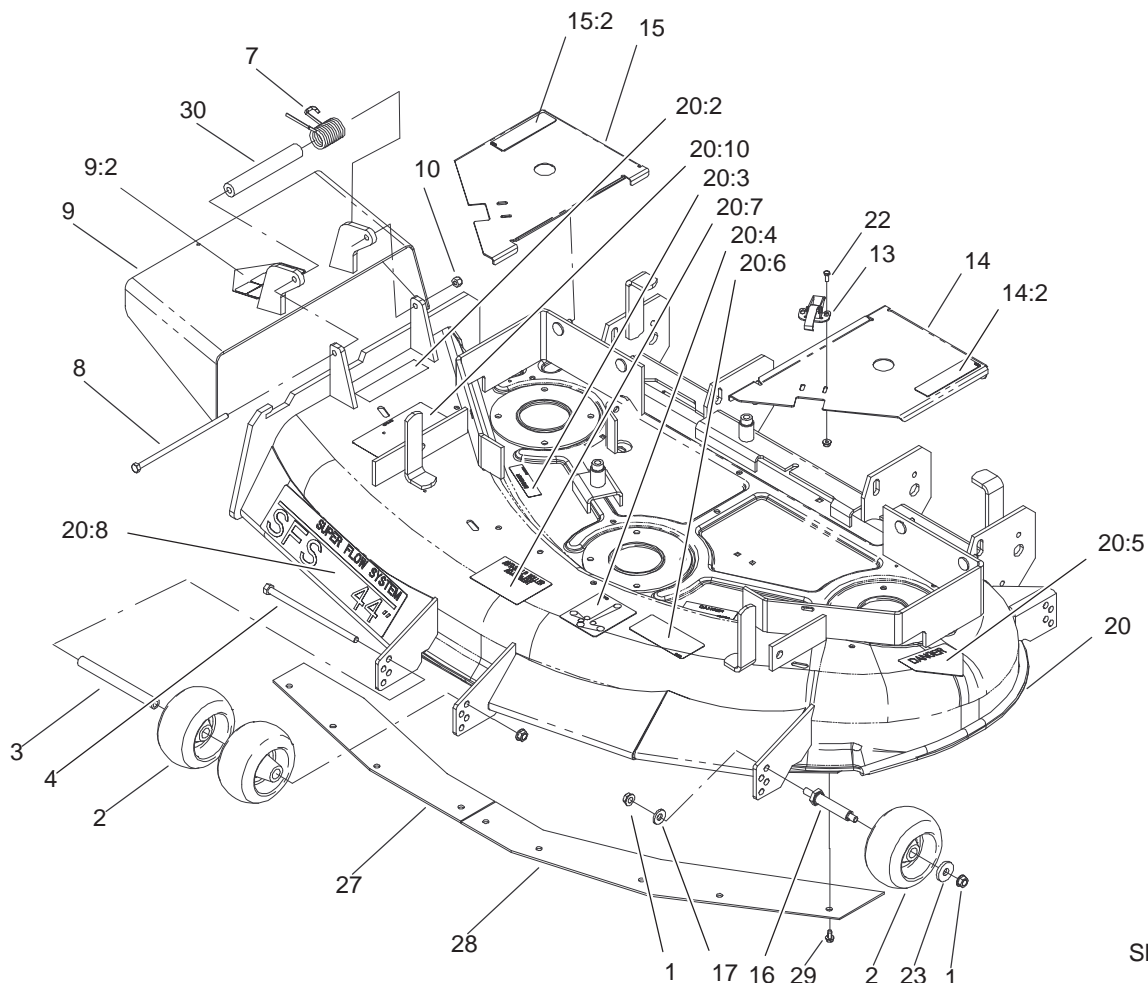

Sheet No.:12

Deck Assembly

Ref. No.	Part No.	Qty.	Description
1	3290-357	7	Nut-HHF
2	68-2730	5	Wheel-Gage
3	98-5967	1	Spacer-Wheel
4	323-28	1	Screw-HH
7	104-8554	1	Spring-Torsion
8	322-50	1	Screw-Cap
9	105-4625	1	Deflector ASM
9:2	54-9220	1	Decal-Danger
10	3296-29	1	Nut-Lock, NI
12	32128-17	4	Nut-Lock, Flange
13	249-21	2	Clamp-Slotted
14	99-3928	1	LH Cover ASM
14:2	67-5360	1	Decal-Danger
15	99-3929	1	RH Cover ASM
15:2	67-5360	1	Decal-Danger
16	99-2842	3	Spacer-Wheel
17	98-5975	3	Washer-Belleville
20	105-1694	1	Deck Service ASM
☆20		1	Deck ASM
20:2	104-8569	1	Decal-Warning, Deflector
20:3	98-5954	3	Decal-Missing, Cover
20:4	99-3943	1	Decal-Routing, Belt
20:5	43-8480	1	Decal-Danger
20:6	93-7818	1	Decal-Torque, Blade Bolt

Ref. No.	Part No.	Qty.	Description
20:7	98-3798	1	Decal-Wheel, Gage
20:8	98-8028	1	Decal-Sfs
20:10	66-1340	1	Decal-Danger
22	3290-321	4	Screw-HWH
23	1-373034	3	Washer-Swivel
27	100-3257-03	1	Plate-Blowout, RH
28	100-3258-03	1	Plate-Blowout, LH
29	12-3270	9	Screw
30	105-4622	1	Spacer - Mounting, Deflector

☆ Not serviced separately

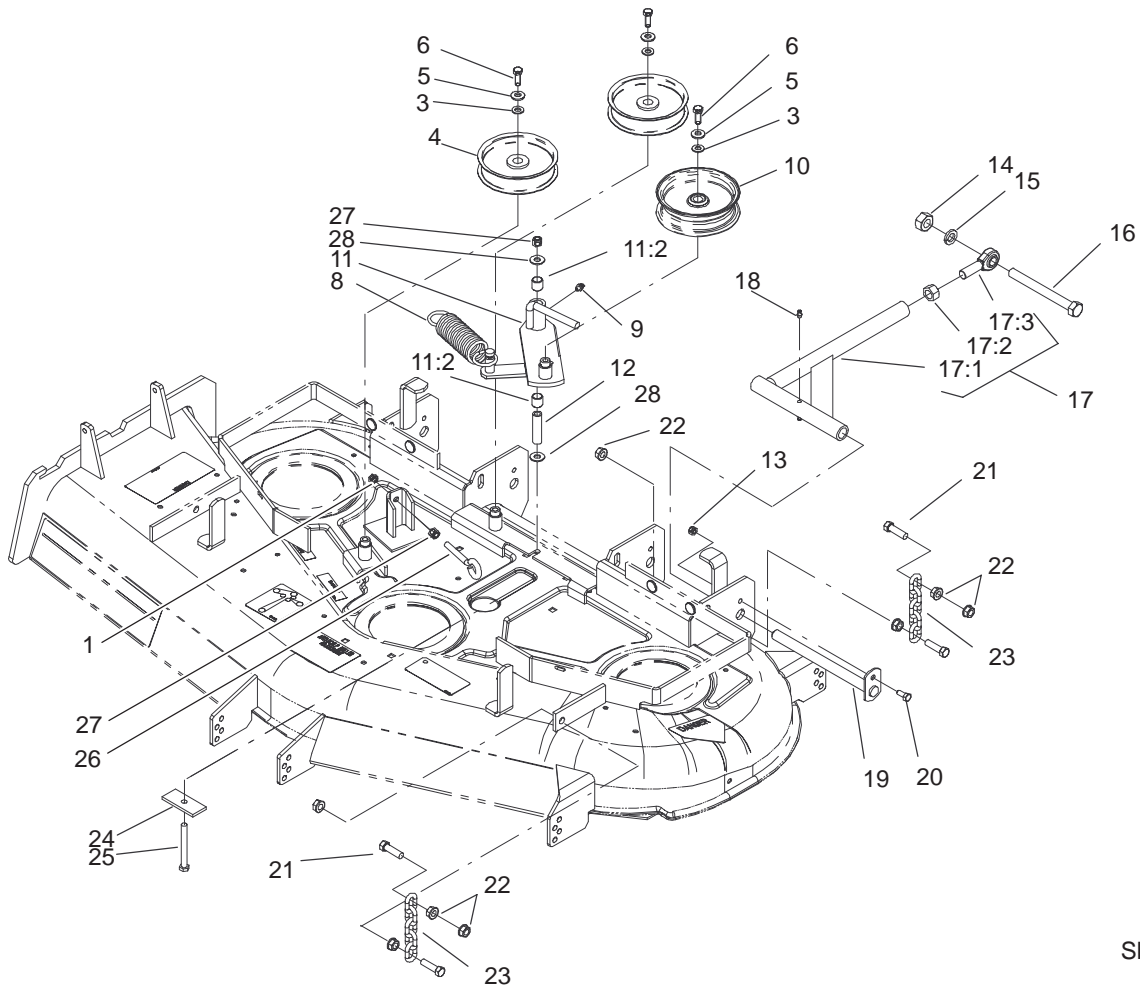

Sheet No.:16

Idler, Pulley/Lift Strut, Chain Assembly

Ref. No.	Part No.	Qty.	Description
1	3217-7	1	Nut-Hex
3	3256-24	3	Washer-Flat
4	1-613098	2	Pulley-Idler
5	98-5975	3	Washer-Belleville
6	323-6	3	Screw-HH
8	1-633151	1	Spring-Extension
9	302-40	1	Fitting-Grease
10	99-8912	1	Pulley-Idler, Flat
11	99-8914	1	Idler Arm ASM
11:2	1-513034	2	Sleeve-Bearing
12	1-603384	1	Bushing-Pivot, Idler
13	3296-29	2	Nut-Lock, NI
14	3217-11	2	Nut-Hex
15	3253-8	2	Washer-Lock
16	1-800344	2	Screw
17	103-1081	2	Strut ASM
17:1	103-1072-01	1	Strut-Deck
17:2	3219-6	1	Nut-Hex
17:3	1-633029	1	Balljoint-Spherical
18	302-19	4	Fitting-Grease
19	1-632199-01	2	Pin-Strut, Deck
20	322-3	2	Screw-HH
21	1-800811	8	Screw-Cap, HH
22	32128-37	16	Nut-HF
23	1-633447	4	Chain-Lift, Deck
24	99-3946-01	1	Plate-Retainer, Bolt

Ref. No.	Part No.	Qty.	Description
25	1-800805	1	Screw-HH
26	94-2547	1	Bolt-Eye
27	3296-39	2	Nut-Lock, NI
28	1-809107	2	Washer-Hardened

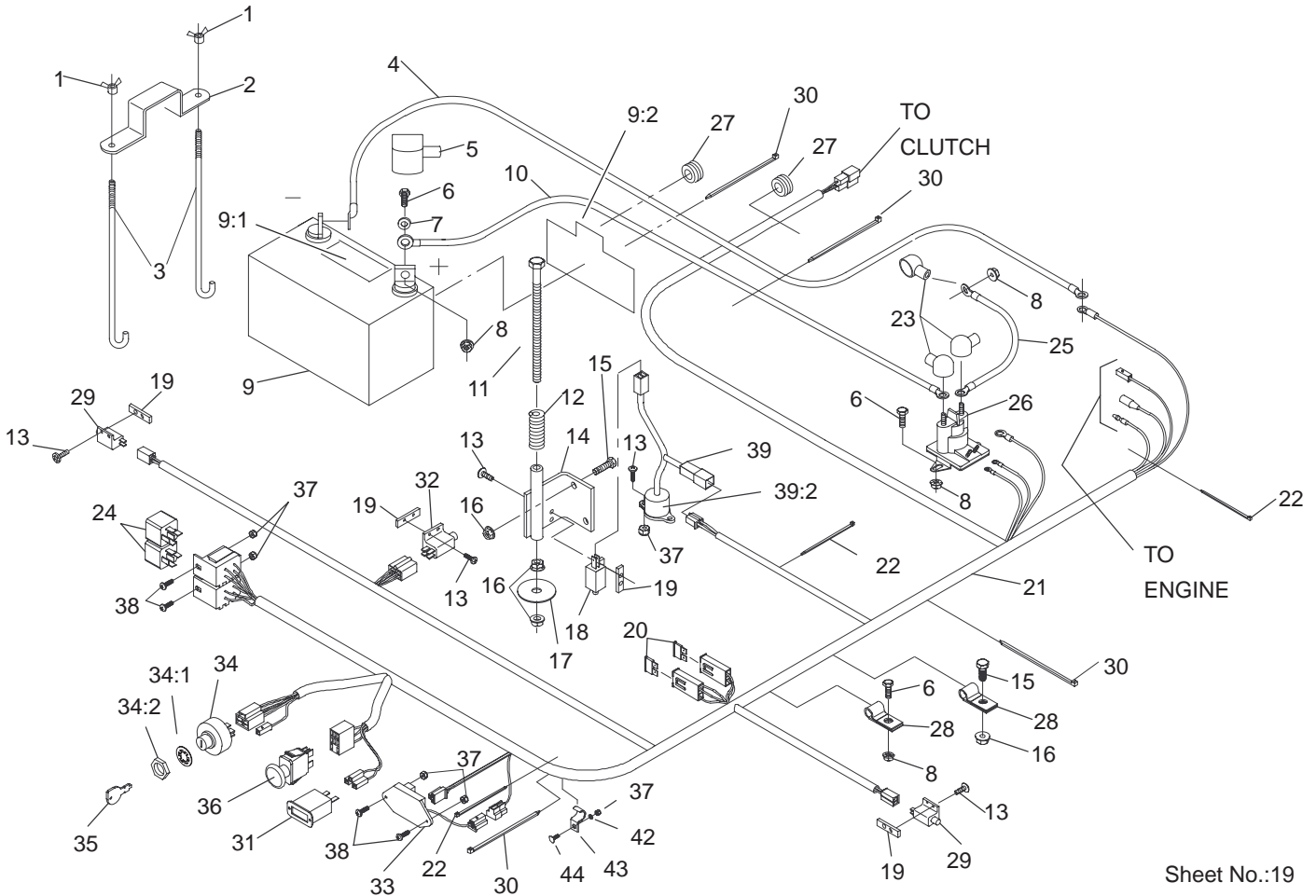

Sheet No.:19

Electrical System Assembly

Ref. No.	Part No.	Qty.	Description
1	1-543792	2	Wingnut
2	1-633652-03	1	Strap-Holddown, Battery
3	1-633651	2	Bolt-Holddown
4	103-0705	1	Cable-Ground, Negative
5	1-543391	1	Insulator-Battery
6	321-4	5	Screw-HH
7	3256-2	2	Washer-Flat
8	32128-33	6	Nut-HF
9	105-1692	1	Battery - 230 Cca
9:1	104-4163	1	Decal-Battery
9:2	104-4164	1	Decal-Battery
10	103-0707	1	Cable-Battery, Pos.
11	1-800282	1	Screw-HH
12	1-523415	1	Spring-Switch, Seat
13	3290-500	10	Screw-PPH
14	1-652072-03	1	Bracket-Switch, Seat
15	322-3	3	Screw-HH
16	32128-20	5	Nut-HF
17	1-653036	1	Washer
18	1-513152	1	Switch-Closed, Normally
19	1-633181	4	Plate-Tapped
20	1-816001	2	Fuse-Type, Blade
21	103-0623	1	Harness-Wire

Ref. No.	Part No.	Qty.	Description
22	1-303287	3	Tie-Plastic
23	1-543393	3	Insulator-Solenoid
24	1-643275	2	Relay
25	1-633306	1	Wire-Starter
26	1-513075	1	Switch-Solenoid
27	1-543286	2	Grommet
28	1-633396	2	Clip-Loom
29	1-513051	2	Switch-Open, Normally
30	1-303335	4	Tie-Plastic
31	1-513374	1	Meter-Hour
32	1-633111	1	Switch
33	100-6186	1	Module-Delay, Seat
34	88-9830	1	Key Switch ASM
34:1	3254-5	1	Washer-Lock, Internal
34:2	218-461	1	Nut-HH
35	63-8360	2	Key-Ignition
36	1-633673	1	Switch-Delta
37	3296-2	7	Nut-Lock
38	1-807513	4	Bolt-CARR
39	1-644427	1	Tilt Switch ASM
39:2	1-643401	1	Decal-Switch, Mercury
42	3256-14	1	Washer-Flat
43	103-1193	1	Clip-Half, Loom
44	1-807533	1	Bolt-CARR

Cylinder/Crankcase Assembly Kawasaki FH500V-ES10

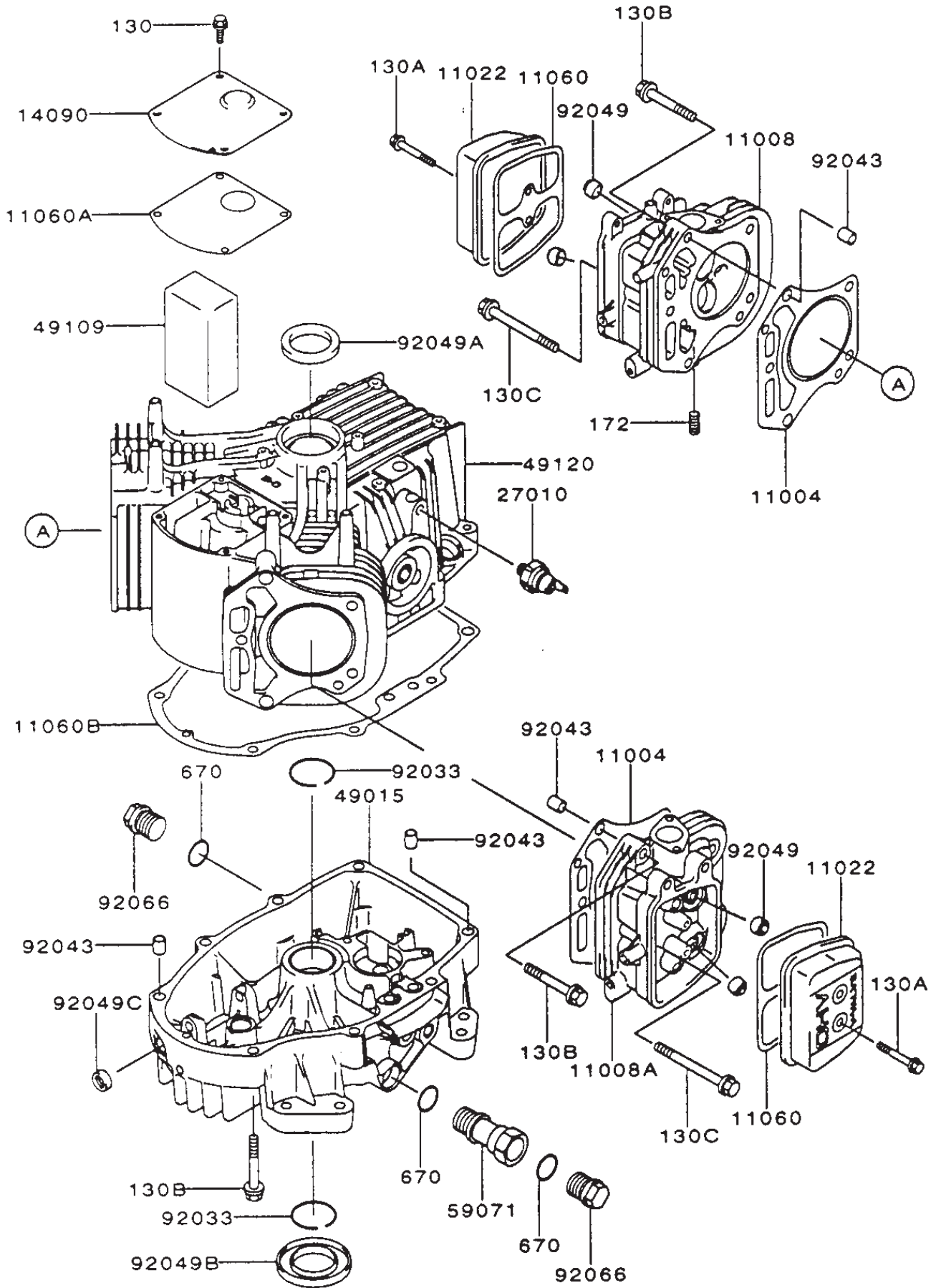

Cylinder/Crankcase Assembly Kawasaki FH500V-ES10

Ref. No.	Part No.	Qty.	Description
11004	11004-7001	2	Gasket-Head
11008	11008-7001	1	Head-Comp-Cylinder No. 1
11008A	11008-7002	1	Head-Comp-Cylinder No. 2
11022	11022-7001	2	Case-Rocker
11060	11060-7001	2	Gasket, Rocker Case
11060A	11060-7002	1	Gasket, Breather
11060B	11060-7007	1	Gasket, Crankcase Cover
14090	14090-7001	1	Cover, Breather
27010	27010-7001	1	Switch
49015	49015-6205	1	Cover-Crankcase
49109	49109-7001	1	Element-Breather
49120	49120-6117	1	Crankcase-Comp
59071	59071-7003	1	Joint
92033	92033-7003	2	Ring-Snap
92043	92043-7001	6	Pin
92049	92049-7001	4	Seal-Oil
92049A	92049-7002	1	Seal-Oil
92049B	92049-7004	1	Seal-Oil
92049C	92049-7005	1	Seal-Oil
92066	92066-7003	2	Plug
130	130B0612	4	Bolt-Flanged
130A	130B0640	4	Bolt-Flanged
130B	130T0850	16	Bolt-Flanged
130C	130T0875	2	Bolt-Flanged
172	172G0818	4	Bolt-Stud
670	670D2016	3	O-Ring

Ref. No.	Part No.	Qty.	Description

Valve/Camshaft Assembly Kawasaki FH500V-ES10

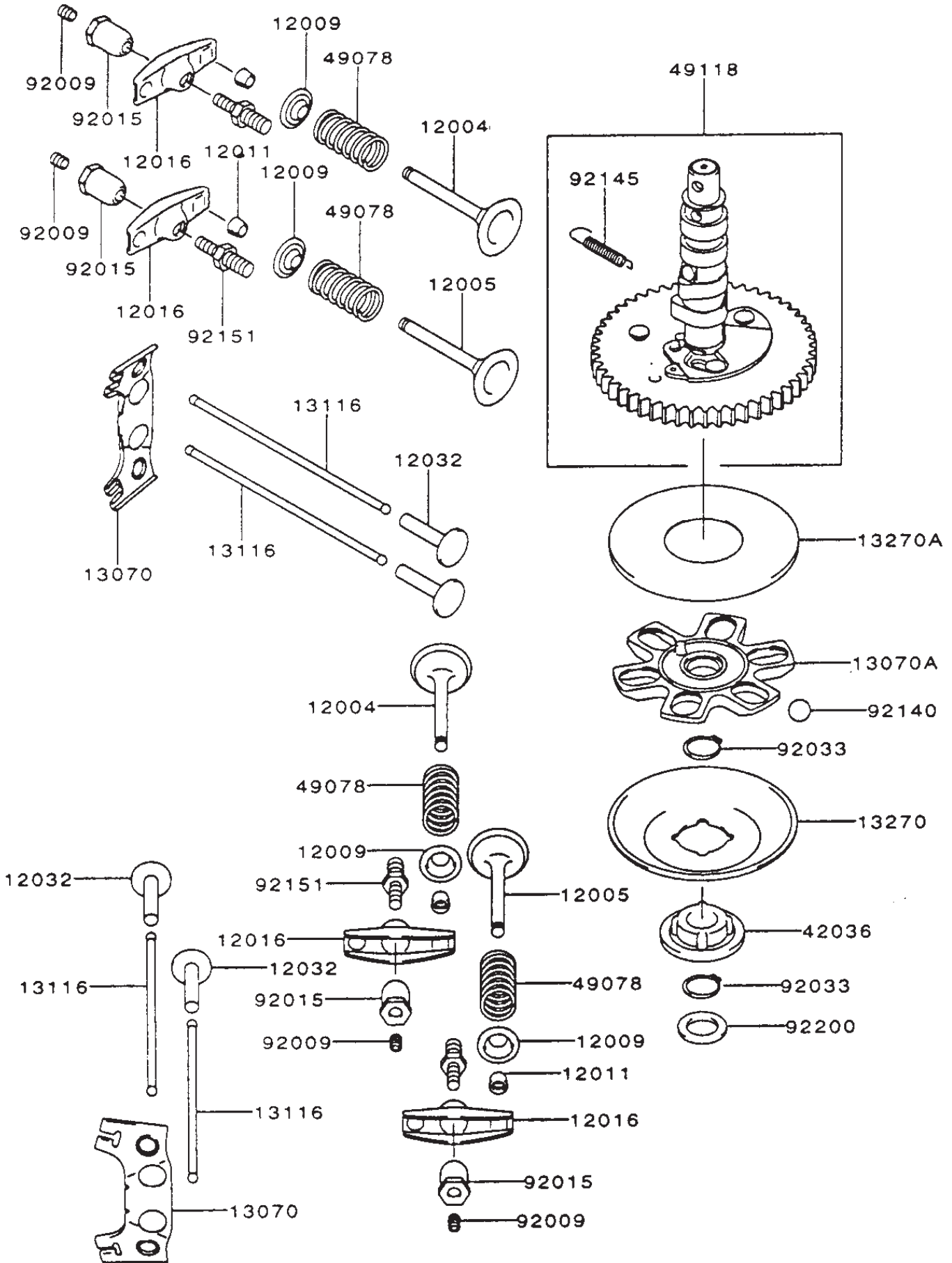

Valve/Camshaft Assembly Kawasaki FH500V-ES10

Ref. No.	Part No.	Qty.	Description
12004	12004-7001	2	Valve-Intake
12005	12005-7001	2	Valve-Exhaust
12009	12009-7001	4	Retainer-Valve Spring
12011	12011-2056	8	Collet
12016	12016-7001	4	Arm-Rocker
12032	12032-7001	4	Tappet
13070	13070-7001	2	Guide
13070A	13070-7002	1	Guide
13116	13116-2057	4	Rod-Push
13270	13270-7002	1	Plate
13270A	13270-7003	1	Plate
42036	42036-7001	1	Sleeve
49078	49078-7001	4	Spring-Engine Valve
49118	49118-7002	1	Camshaft-Comp
92009	92009-2341	4	Screw
92015	92015-2253	4	Nut
92033	92033-7001	2	Ring-Snap
92140	92140-7002	6	Ball
92145	92145-7001	1	Spring
92151	92151-7001	4	Bolt
92200	92200-7001	1	Washer

Ref. No.	Part No.	Qty.	Description

Cooling-Equipment Assembly Kawasaki FH500V-ES10

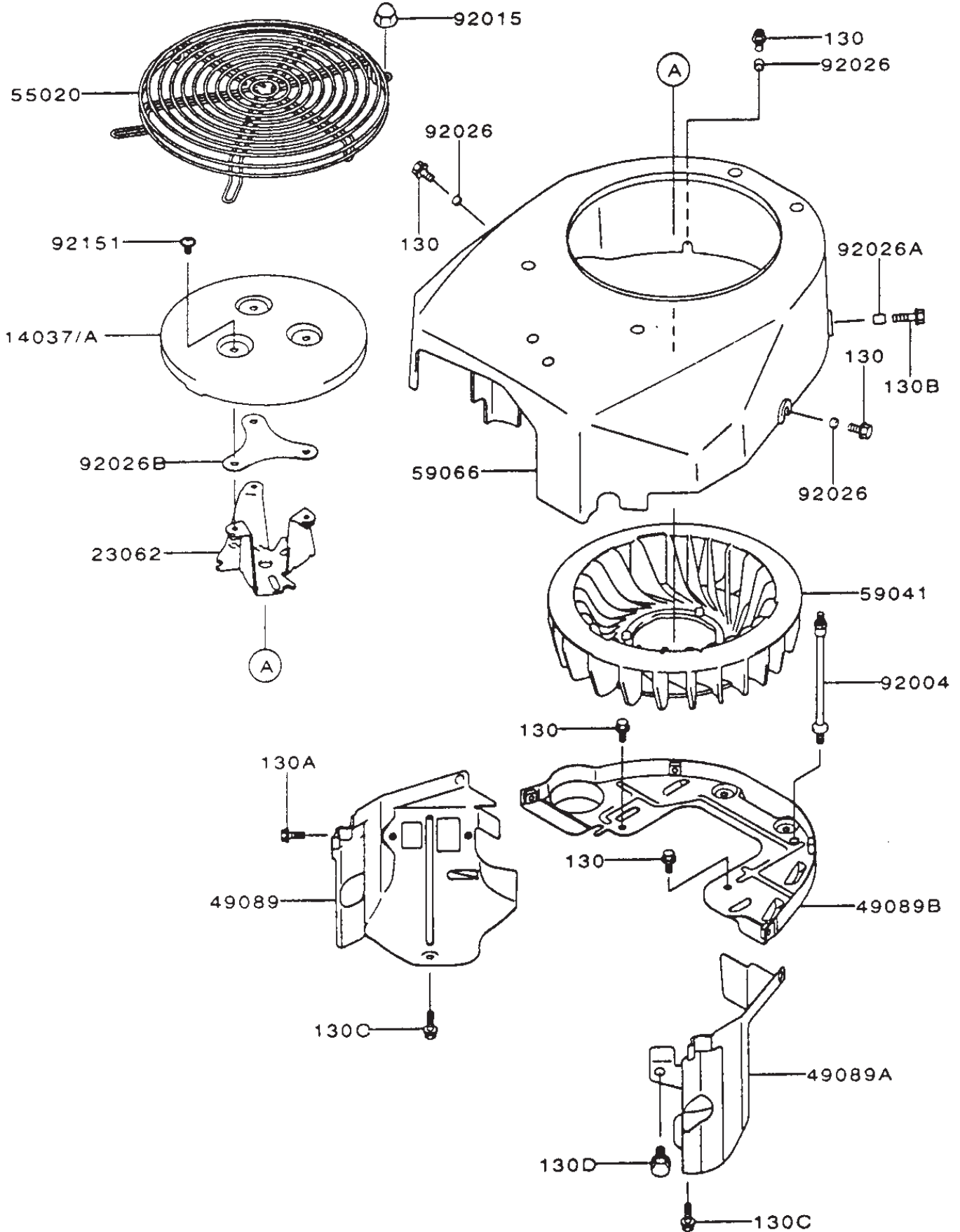

Cooling-Equipment Assembly Kawasaki FH500V-ES10

Ref. No.	Part No.	Qty.	Description
14037	14037-7003	1	Screen
14037A	14037-7003-9H	1	Screen
23062	23062-7002	1	Bracket-Comp
49089	49089-7001	1	Shroud-Engine
49089A	49089-7002	1	Shroud-Engine
49089B	49089-7003	1	Shroud-Engine
55020	55020-7001	1	Guard
59041	59041-7001	1	Fan
59066	59066-7002	1	Housing-Fan
92004	92004-2148	2	Stud
92015	92015-1170	4	Nut
92026	92026-7001	3	Spacer, 6.2x7.9x5
92026A	92026-7003	1	Spacer, 6.5x7.9x10.5
92026B	92026-7004	1	Spacer
92151	92151-7009	3	Bolt, 6x10
130	130B0612	5	Bolt-Flanged
130A	130B0616	2	Bolt-Flanged
130B	130B0620	1	Bolt-Flanged
130C	130B0625	2	Bolt-Flanged
130D	130B0816	1	Bolt-Flanged

Ref. No.	Part No.	Qty.	Description

Electric-Equipment Assembly Kawasaki FH500V-ES10

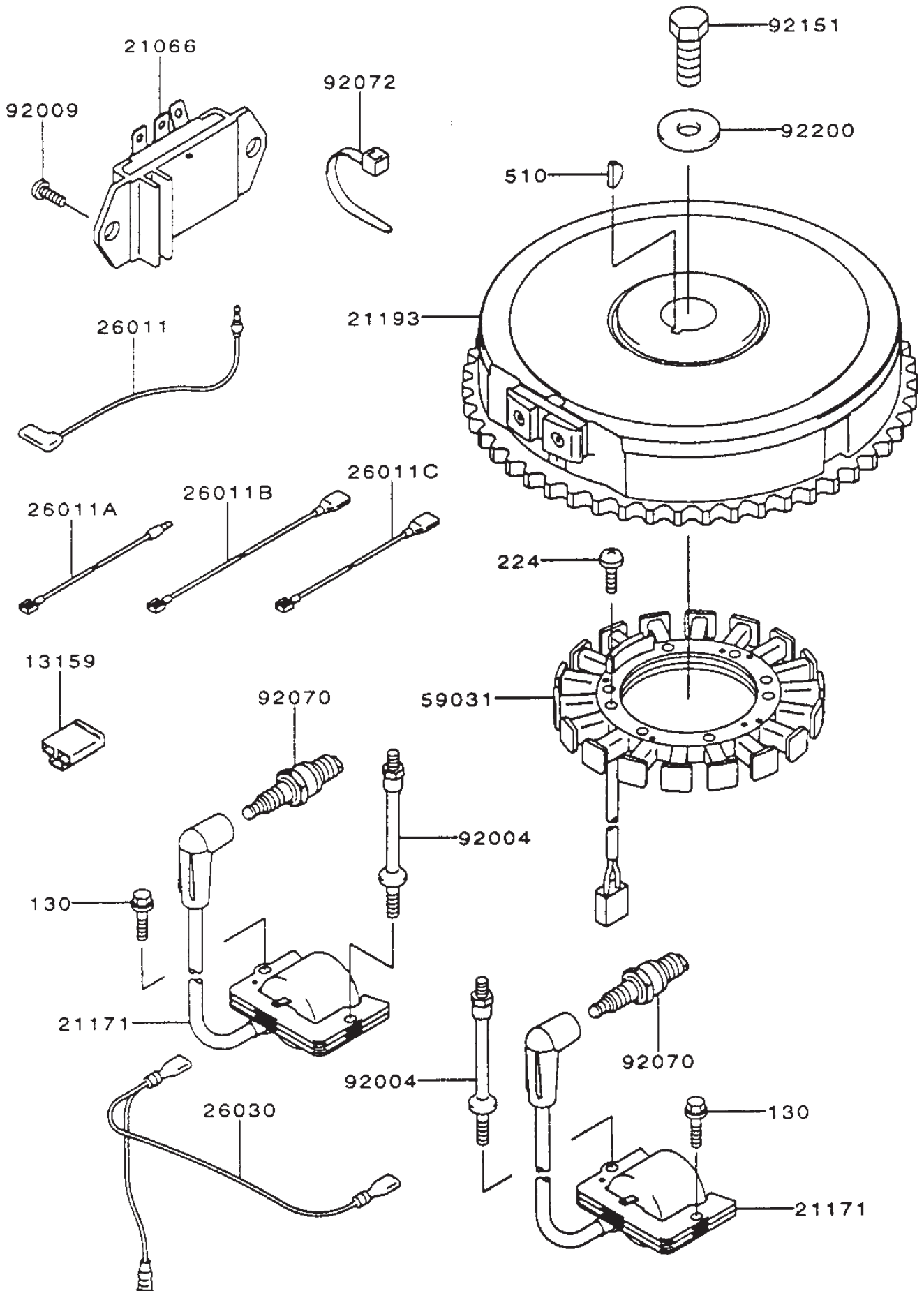

Electric-Equipment Assembly Kawasaki FH500V-ES10

Ref. No.	Part No.	Qty.	Description
13159	13159-7001	1	Connector
21066	21066-7001	1	Regulator-Voltage
21171	21171-7001	2	Coil-Assy-Ignition
21193	21193-7001	1	Flywheel-Assy
26011	26011-7001	1	Wire-Lead
26011A	26011-7002	1	Wire-Lead
26011B	26011-7003	1	Wire-Lead
26011C	26011-7004	1	Wire-Lead
26030	26030-7001	1	Harness
59031	59031-7001	1	Coil-Charging
92004	92004-2147	2	Stud
92009	92009-2308	2	Screw
92070	92070-7001	2	Plug-Spark (RCJ8Y)
92072	92072-7001	2	Band
92151	92151-2097	1	Bolt, 12x30
92220	92220-7002	1	Washer
130	130B0620	1	Bolt-Flanged
224	224B0520	4	Screw-Pan-WP-Cros
510	510A5100	1	Key-Woodruff

Ref. No.	Part No.	Qty.	Description

Control-Equipment Assembly Kawasaki FH500V-ES10

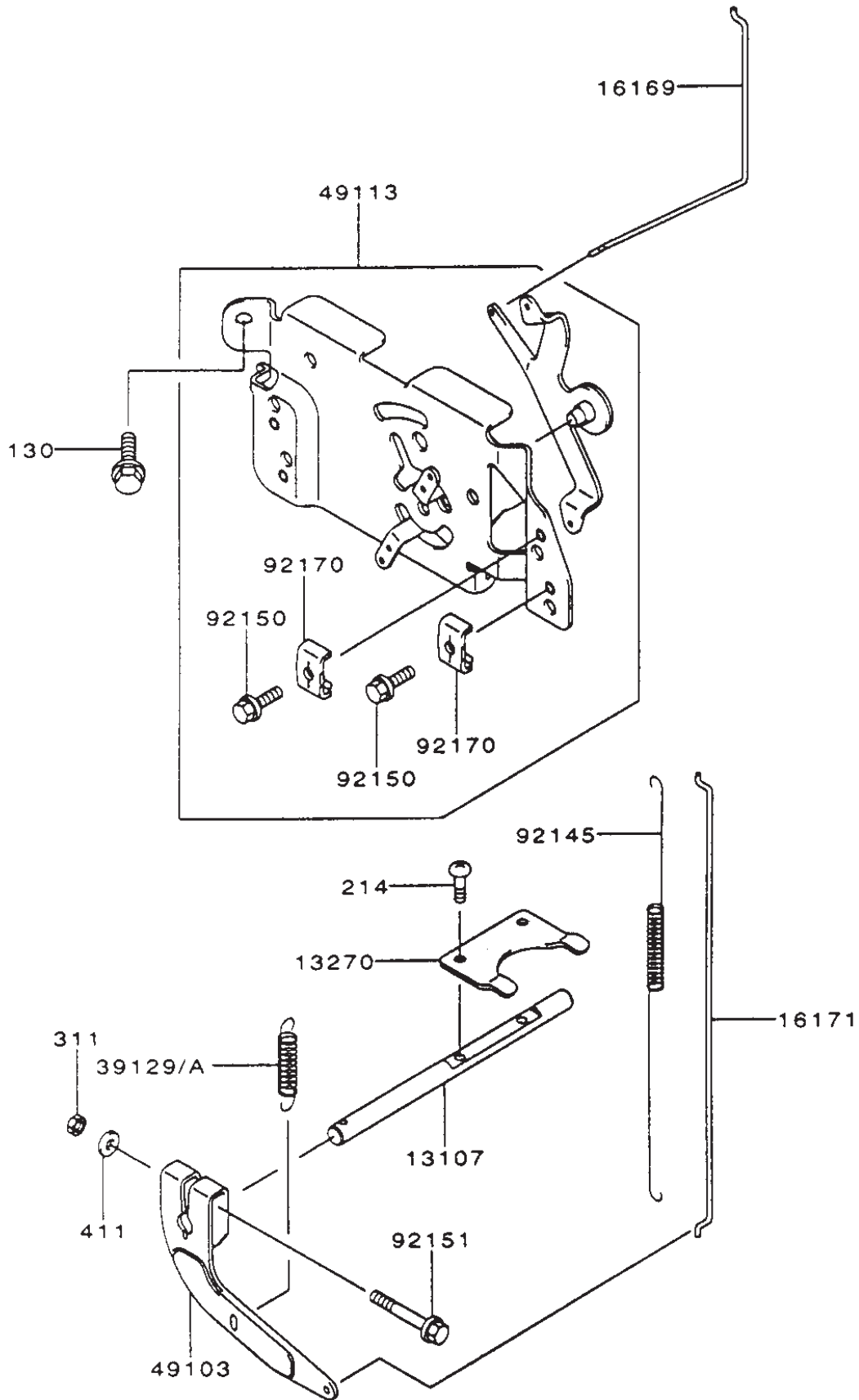

Control-Equipment Assembly Kawasaki FH500V-ES10

Ref. No.	Part No.	Qty.	Description
13107	13107-7002	1	Shaft
13270	13270-7006	1	Plate
16169	16169-7001	1	Link-Choke
16171	16171-7001	1	Link
39129	39129-7002	1	Spring-Governor
39129A	39129-7003	1	Spring-Governor
49103	49103-7001	1	Arm-Governor
49113	49113-7002	1	Panel-Comp-Control
92145	92145-7003	1	Spring
92150	92150-2182	2	Bolt, 5x18
92151	92151-7006	1	Bolt, 6x30
92170	92170-7001	2	Clamp
130	130B0612	2	Bolt-Flanged
214	214B0408	2	Screw-Pan
311	311B0600	1	Nut-Hex
411	411B0600	1	Washer-Plain

Ref. No.	Part No.	Qty.	Description

Carburetor Assembly Kawasaki FH500V-ES10

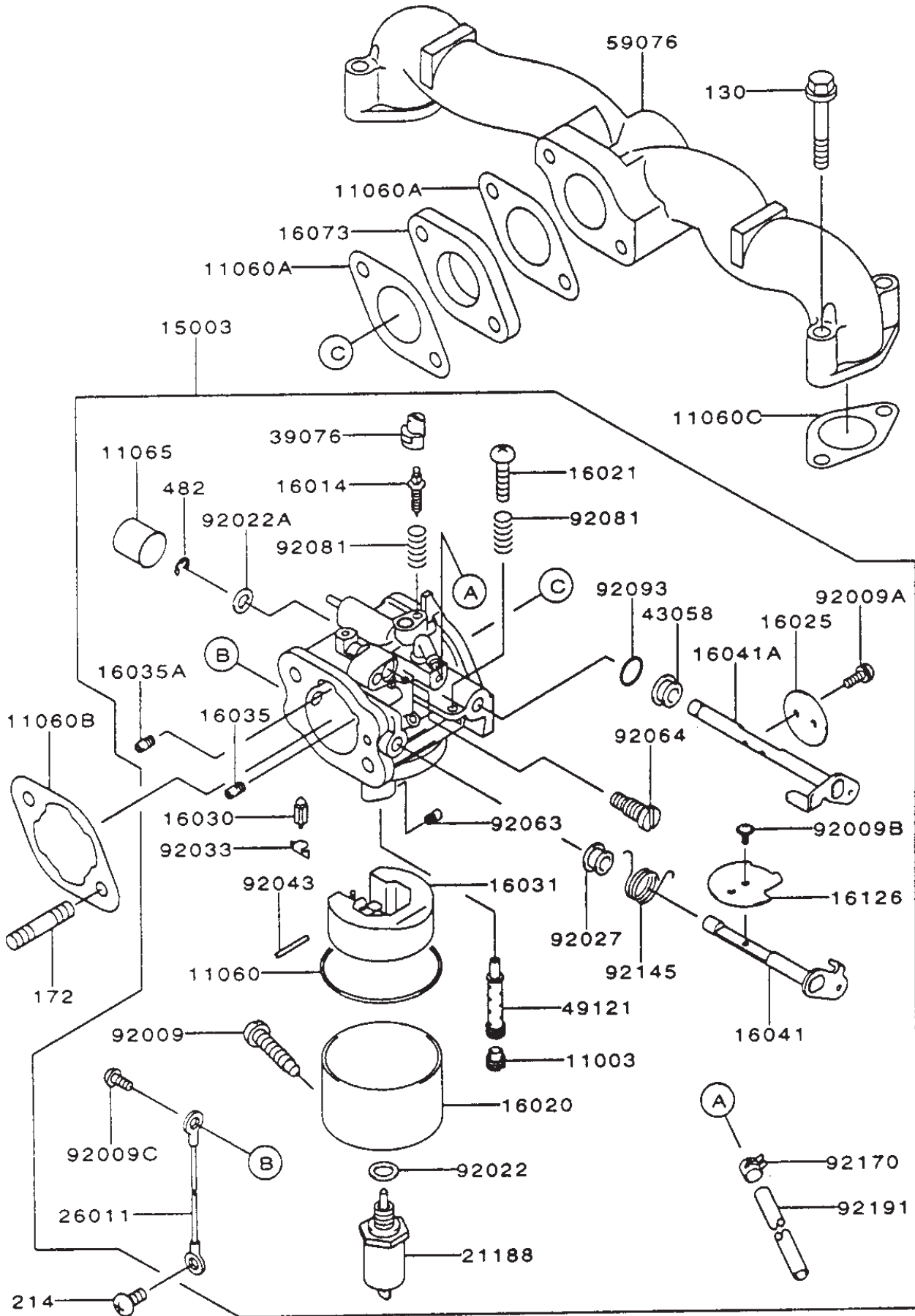

Carburetor Assembly Kawasaki FH500V-ES10

Ref. No.	Part No.	Qty.	Description	Ref. No.	Part No.	Qty.	Description
11003	11003-2105	1	Seat-Valve				
11060	11060-2406	1	Gasket				
11060A	11060-7003	2	Gasket, Insulator				
11060B	11060-7004	1	Gasket, Air Filter				
11060C	11060-7005	2	Gasket				
11065	11065-2061	1	Cap				
15003	15003-2632	1	Carburetor-Assy				
16014	16014-2080	1	Screw-Pilot Air				
16020	16020-2141	1	Chamber-Float				
16021	16021-2060	1	Screw-Throttlestop				
16025	16025-2193	1	Valve-Throttle, #130				
16030	16030-2067	1	Valve-Float				
16031	16031-2066	1	Float				
16035	16035-2060	1	Jet-Air, #1.7				
16035A	16035-2061	1	Jet-Air, #1.2				
16041	16041-2252	1	Shaft-Carburetor, Choke				
16041A	16041-2253	1	Shaft-Carburetor Throttle				
16073	16073-7001	1	Insulator				
16126	16126-2218	1	Valve				
21188	21188-2011	1	Solenoid				
26011	26011-2281	1	Wire-Lead				
39076	39076-2053	1	Limitter				
43058	43058-3716	1	Ring				
49121	49121-2222	1	Nozzle-Main				
59076	59076-7001	1	Manifold-Intake				
92009	92009-2015	1	Screw				
92009A	92009-2024	2	Screw				
92009B	92009-2081	1	Screw				
92009C	92009-2400	1	Screw				
92022	92022-2231	1	Washer				
92022A	92022-2239	1	Washer				
92027	92027-2025	1	Collar				
92033	92033-2067	1	Ring-Snap				
92043	92043-2226	1	Pin				
92063	92063-2358	1	Jet-Main				
92064	92064-2125	1	Jet-Pilot				
92081	92081-2009	2	Spring				
92093	92093-2002	1	Seal				
92145	92145-2061	1	Spring				
92170	92170-2023	1	Clamp				
92191	92191-2067	1	Tube				
130	130B0635	4	Bolt-Flanged				
172	172G0685	2	Bolt-Stud				
214	214B0510	1	Screw-Pan				
482	482L400	1	Circlip-Type-E				

