



## **72" Flex Deck**

### **Side Discharge Mower**

**Model No. 30799—220000001 and Up**

**Operator's Manual**



## Warning



The engine exhaust from this product contains chemicals known to the State of California to cause cancer, birth defects, or other reproductive harm.

# Contents

	<b>Page</b>
Introduction .....	3
Safety and Instruction Decals .....	4
Specifications .....	6
General Specifications .....	6
Optional Equipment .....	6
Setup .....	7
Loose Parts .....	7
Setup Instructions .....	8
Mount Hose Clamp .....	8
Grass Deflector .....	8
Mount Rear Castor Wheels .....	8
Connect Right-hand Push Arm To Cutting Unit ..	8
Connect Left-hand Push Arm To Cutting Unit ...	9
Mount Front Lift Arm .....	10
Mount Rear Lift Bracket .....	11
Install Drive Shaft To Traction Unit .....	11
Install Lift Chains .....	12
Adjust Counter Balance Spring .....	12
Grease Cutting Unit .....	12
Install Rear Weight .....	12

	<b>Page</b>
Before Operating .....	13
Check Lubricant In Gear Box .....	13
Adjusting Height-of-cut .....	13
Check Tire Pressure .....	14
Adjust Skid .....	15
Adjust Rollers .....	15
Operation .....	16
Grass Deflector .....	16
Operating Tips .....	16
Maintenance .....	17
Greasing The Cutting Unit .....	17
Trouble Shooting .....	18
Separating Cutting Unit From Traction Unit ...	19
Mounting Cutting Unit To Traction Unit .....	19
Adjusting Drive Belts .....	19
Replacing Drive Belts .....	20
Servicing Front Bushings In Castor Arms .....	20
Servicing Castor Wheels And Bearings .....	21
Replacing Grass Deflector .....	21
Removing Cutter Blade .....	21
Inspecting And Sharpening Blade .....	22
Correcting Cutting Unit Mismatch .....	23
The Toro General Commercial Products Warranty ..	24

# Introduction

Read this manual carefully to learn how to operate and maintain your product properly. The information in this manual can help you and others avoid injury and product damage. Although Toro designs and produces safe products, you are responsible for operating the product properly and safely.

Whenever you need service, genuine Toro parts, or additional information, contact an Authorized Service Dealer or Toro Customer Service and have the model and serial numbers of your product ready. The two numbers are stamped into a plate that is riveted to the mower.

Write the product model and serial numbers in the space below:

<b>Model No.</b> _____
<b>Serial No.</b> _____

This manual identifies potential hazards and has special safety messages that help you and others avoid personal injury and even death. **Danger**, **Warning**, and **Caution** are signal words used to identify the level of hazard. However, regardless of the hazard, be extremely careful.

**Danger** signals an extreme hazard that *will* cause serious injury or death if you do not follow the recommended precautions.

**Warning** signals a hazard that *may* cause serious injury or death if you do not follow the recommended precautions.

**Caution** signals a hazard that may cause minor or moderate injury if you do not follow the recommended precautions.

This manual uses two other words to highlight information. **Important** calls attention to special mechanical information and **Note:** emphasizes general information worthy of special attention.

# Safety and Instruction Decals



Safety decals and instructions are easily visible to the operator and are located near any area of potential danger. Replace any decal that is damaged or lost.



93-3709

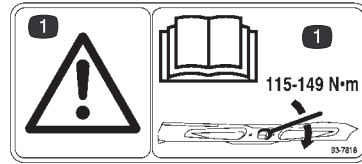

93-7818

1. Warning—torque the blade bolt to 115–149 N•m. Read the operator's manual for further instructions.



100-6582

1. Warning—Cutting hazard of hands

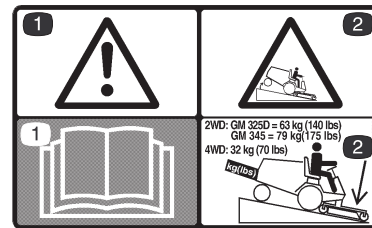

104-2526

1. Warning—read the operator's manual.
2. Lower cutting unit before going down hills. When operating the Groundsmaster 325-D or 345 two-wheel drive or four-wheel drive, rear weight must be added to the machine.



93-6696

1. Warning—part is spring loaded. Read the operator's manual.



54-9220

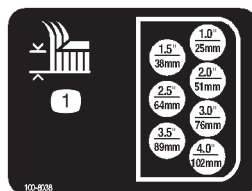

100-8038

1. Height-of-cut setting for rear deck chain

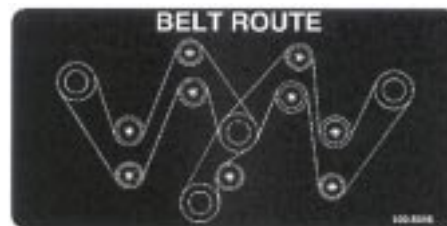

100-8046

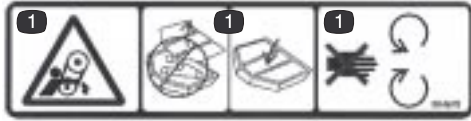

**100-6578**

1. Entanglement hazard—keep belt covers in place. Stay away from moving parts.



**93-6697**

1. Change the gearbox oil every 50 hours. Read the operator's manual for further instructions.



**93-7824**

1. Thrown object hazard—keep bystanders away.
2. Thrown object hazard from mower—keep the deflector in place.
3. Cutting/dismemberment hazard of hands or feet—stay away from rotating blades and moving parts.

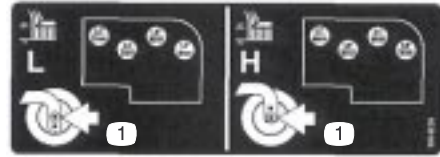

**100-8039**

1. Height-of-cut setting for rear castor wheels on left chamber

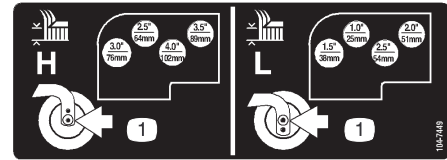

**104-7449**

1. Height-of-cut setting for rear castor wheels on right chamber

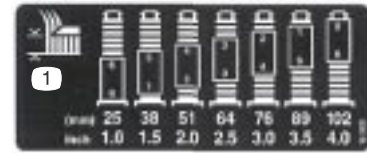

**92-3035**

1. Height-of-cut setting for front castor wheels.

# Specifications

**Note:** Specifications and design subject to change without notice.

## General Specifications

Configuration	Three blades, one blade center section, and two 1 blade floating wings. Wings flex up and down 12 degrees in a single plane perpendicular to from center section.
Height of Cut	Adjustable front and rear, in .50 inch increments from 1 to 4 inches.
Construction	12-gauge steel, 5.25 inches deep, welded construction and reinforced with 10-gauge steel channels.
Blades	Three 25 inch long, .25 inch thick, heat treated steel blades.
Cutter Drive	PTO driven gearbox with 1.26–1 spiral bevel gears. One “B” section belt on center section. One “B” section belt on each wing. Center section tensioned through spring loaded idler. Wings tensioned through adjustable fixed idler.
Spindles	Cast iron housing, 1-1/4 inch dia shaft with welded blade retainer. Turning on two greaseable tapered roller bearings. A positive splined connection attaches pulley to spindle shaft.
Castor Wheels	Front: Four 8 inch pneumatic wheels with greaseable roller bearings. Rear: Two 8 inch pneumatic wheels with greaseable roller bearings (one on each wing). Center section suspended from push arms.
Anti Scalp	Anti-scalp cup (11 inch diameter) located on each blade. One anti-scalp roller on rear of center section. Adjustable skid on right wing.
Trimability	34, uncut circle, 25, uncut circle with use of individual wheel brakes.
Tip Speed	15,000 ft./min. @ 3200 engine RPM.
Discharge	Left-hand, side discharge (recycler kit available).
Belt Covers	Steel covers bolted down, meets CE requirements.
Weight	550 lb.
Width	83-1/2 in.

## Optional Equipment

High Lift Blade	Part No. 23-2410
Height of cut spacers 1/4	Part No. 54-8810
Foam Filled 8” Tire	Part No. 93-5974
Recycler Kit	Model No. 30838
Atomic Blade	Part No. 106-4354

# Setup

**Note:** Determine the left and right sides of the machine from the normal operating position.

## Loose Parts

**Note:** Use this chart as a checklist to ensure that all parts necessary for assembly have been received. Without these parts, total setup cannot be completed. Some parts may have already been assembled at the factory.

Description	Qty.	Use
Hose clamp	1	Install hose clamp
Hose bracket	2	
Capscrew, 1/4 x 1 in.	2	
Nut	2	
Push arm adapter	1	Install right push arm adapter
Push arm plate	1	
Capscrew, 3/8 x 2-3/4 in.	4	
Flat washer	4	
Nut	4	
Front lift arm	1	
Locknut	2	
Capscrew, 3/8 x 3 in.	2	
Rear lift bracket	1	Install rear lift support
Square U-bolt	1	
U-bolt	1	
Height-of-cut chain	1	
Clevis pin	1	
Hairpin	1	
Nut	6	
Capscrew, 3/8 x 7/8 in.	4	Secure covers for CE
Roll pin	1	Install drive shaft
Danger decal	1	Place over 54-9220 on deflector for CE.
Parts catalog	1	
Operator's manual	1	Read before operating the machine.
Registration card	1	Fill out and return to Toro.

# Setup Instructions

## Mount Hose Clamp

1. Using dimensions shown in figure 1, locate, mark and drill (2) .28 in. dia. holes in traction unit platform. Use caution when drilling as there are hoses and cables under platform.

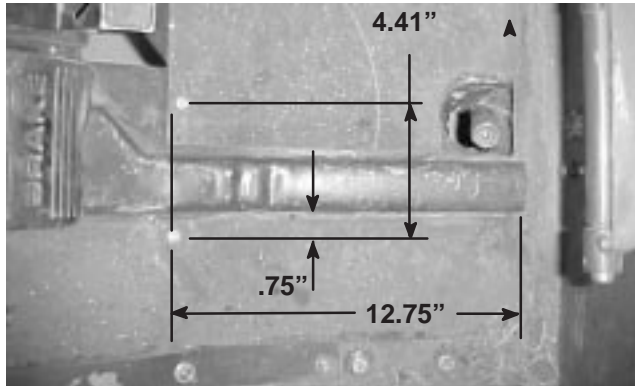

Figure 1

2. Secure hoses to under side of platform with clamp, (2) brackets, capscrews and nuts. Position brackets to fit contour of hoses and platform.

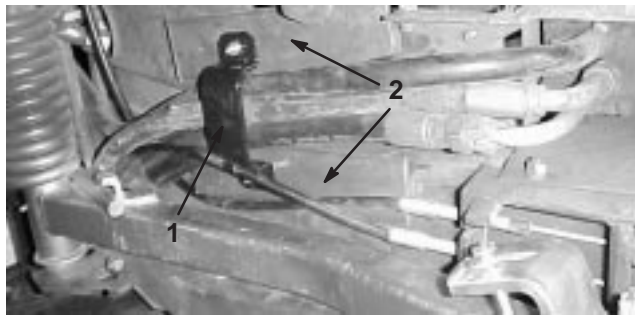

Figure 2

1. Clamp
2. Bracket

## Grass Deflector

1. Remove shipping bands allowing deflector to be lowered.



### Warning



Deflector is spring loaded in the down position and will rotate downward, if not restrained, when band is cut. If done improperly, personal injury may occur.

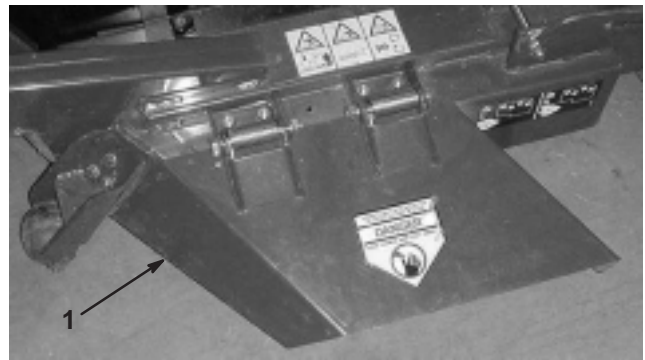

Figure 3

1. Grass deflector

## Mount Rear Castor Wheels

The rear castor wheels are shipped secured upside down to deck brackets.

1. Remove capscrew and locknut securing front of rear castor pivot to deck bracket.



Figure 4

1. Rear castor pivot arm
2. Turn pivot right side up and secure front of castor pivot arm to front of deck bracket with capscrew and locknut removed.
3. Align the pivot arm holes with selected height-of-cut bracket holes in the deck frame, install clevis pin and secure with hairpin cotter.
4. Repeat procedure on other castor wheel assembly.

## Connect Right-hand Push Arm To Cutting Unit

**Note:** Ball joints are shipped with traction unit.

1. Thread a jam nut fully onto ball joint.

- Thread ball joint into push arm adapter until a dimension of 2-3/8 in. from end of adapter to center of ball joint is attained. Do not tighten jam nut.

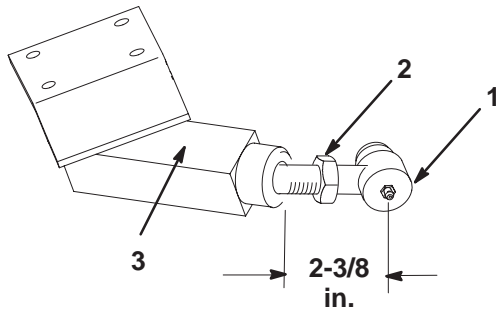

**Figure 5**

- |               |                     |
|---------------|---------------------|
| 1. Ball joint | 3. Push arm adapter |
| 2. Jam nut    |                     |

- Remove 2 flange head capscrews and flange nuts securing right hand ball joint mount to castor arm. Remove ball joint mount from castor arm.
- Install ball joint to right hand ball joint mount with a castle nut and cotter pin (Fig. 6).
- Loosely mount push arm adapter to bottom of right push arm with a push arm bracket and (4) capscrews, flat washers, and flange head locknuts. Push arm bracket to be positioned over and against end of right push arm (Fig. 6).

**Note:** Push arm bracket must contact end of push arm.

- Tighten fasteners securing right push arm adapter to right push arm.
- Move cutting unit into position in front of traction unit.

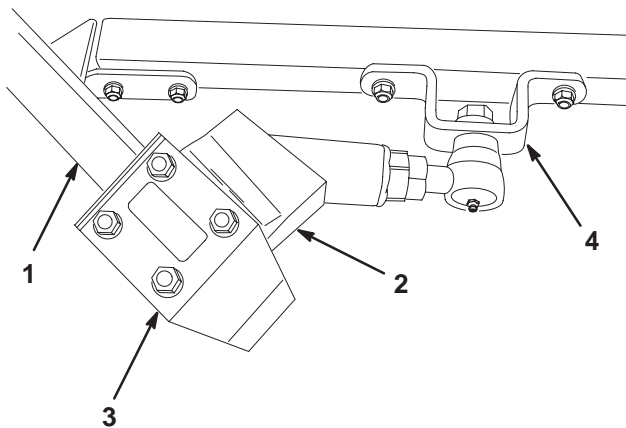

**Figure 6**

- |                        |                     |
|------------------------|---------------------|
| 1. Right hand push arm | 3. Push arm bracket |
| 2. Push arm adapter    | 4. Ball joint mount |

⚠
Warning
⚠

**Since the right hand push arm is spring loaded to about 100 pounds, a helper is needed to push the arm down. Sudden release of the push arm could cause injury.**

- Have a helper carefully push down on the right push arm until holes in ball joint mount line up with holes in castor arm. Immediately slide a 4 x 4 in. block of wood between top of push arm and underside of chassis.
- Secure ball joint mount to castor arm with 2 flange head capscrews and flange nuts previously removed.

**Note:** Capscrew heads to be positioned on inside of castor arm.

- Tighten large jam nut securing ball joint to push arm adapter (Fig. 5). When tightening jam nut, hold ball joint straight to permit proper oscillation during raising and lowering of cutting unit. Carefully remove wood block holding push arm down.

## Connect Left-hand Push Arm To Cutting Unit

⚠
Warning
⚠

**Since the left hand push arm is spring loaded to about 100 pounds, a helper is needed to push the arm down. Sudden release of the push arm could cause injury.**

- Thread a jam nut fully onto ball joint.
- Thread ball joint into left push arm until a dimension of 2-3/8 in. from end of push arm to center of ball joint is attained. Do not tighten jam nut.

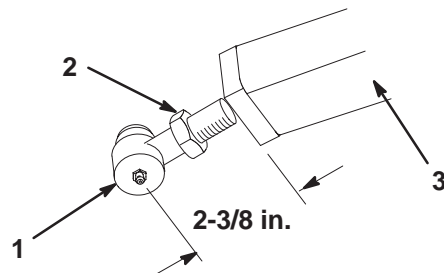

**Figure 7**

- |               |                  |
|---------------|------------------|
| 1. Ball joint | 3. Left push arm |
| 2. Jam nut    |                  |

3. Remove 2 flange head capscrews and flange nuts securing left-hand ball joint mount to castor arm. Remove ball joint mount from castor arm.
4. Install ball joint to left-hand ball joint mount with a castle nut and cotter pin.

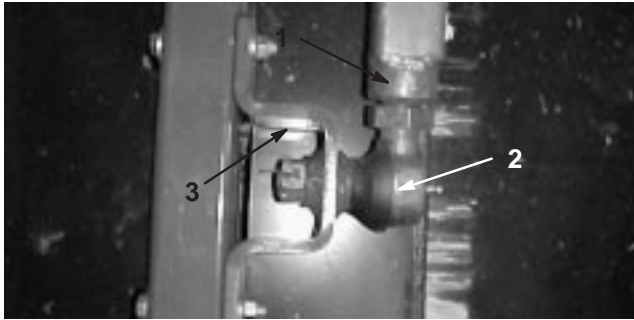

**Figure 8**

1. L.H. Push arm
2. Ball joint
3. Ball joint mount

5. Have a helper carefully push down on the push arm until holes in ball joint mount line up with holes in castor arm. Immediately slide a 4 x 4 in. block of wood between top of push arm and underside of chassis.



### Warning



**Make sure the wooden block does not slip out accidentally. Sudden release of the push arm could cause injury.**

6. Secure ball joint mount to castor arm with flange head capscrews and flange nuts previously removed.

**Note:** Flange head capscrew heads to be positioned on inside of castor arm.

7. Tighten large jam nut securing ball joint to push arm. When tightening jam nut, hold ball joint straight to permit proper oscillation during raising and lowering of cutting unit. Carefully remove wood block holding push arm down.

**Note:** Periodically check and tighten the push arm adapter capscrews.

## Mount Front Lift Arm

1. Remove rubber bumper from bottom of traction T-bar.

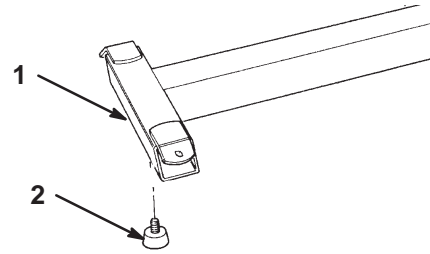

**Figure 9**

1. Traction T-bar
2. Rubber bumper

2. Slide front lift arm onto traction unit t-bar, positioning as shown in Figure 10.
3. Secure front lift arm to t-bar with with 2 capscrews and locknuts.

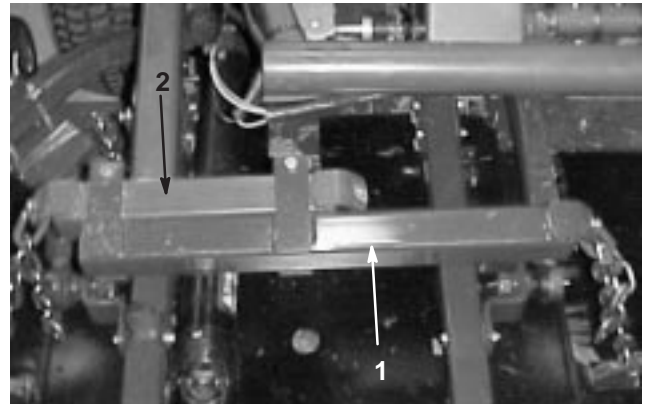

**Figure 10**

1. Front lift arm
2. Traction unit T-bar

## Mount Rear Lift Bracket

1. Loosely mount rear lift bracket to right push arm with square U-bolt, 2 nuts, and flange nuts. Bracket to be positioned on push arm so it is centered and parallel to castor arm.



**Figure 11**

- |                  |           |
|------------------|-----------|
| 1. Lift bracket  | 3. U-bolt |
| 2. Square U-bolt |           |



**Figure 12**

- |                 |               |
|-----------------|---------------|
| 1. Lift bracket | 2. Castor arm |
|-----------------|---------------|

2. Hook H.O.C. chain onto remaining U-bolt.
3. Thread a hex nut onto each end of U-bolt.
4. Loosely mount U-bolt and H.O.C. chain to rear lift bracket 2 nuts and 2 flange nuts
5. Mount height-of-cut chain to 2 in. height-of-cut hole with clevis pin and hairpin cotter.
6. Position rear castors in 2 in. height-of-cut.
7. Adjust nuts on U-bolt until rear of deck is parallel to floor (Distance from floor to bottom rear edge of all three deck chambers must be equal).

## Install Drive Shaft To Traction Unit

**Note:** To ease installation of PTO shaft, remove right traction tire.

1. Slide smaller yoke end of drive shaft onto traction unit PTO shaft while aligning mounting holes. Secure with roll pin.

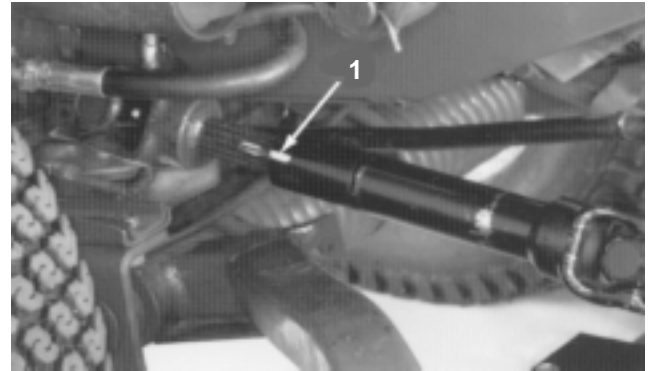
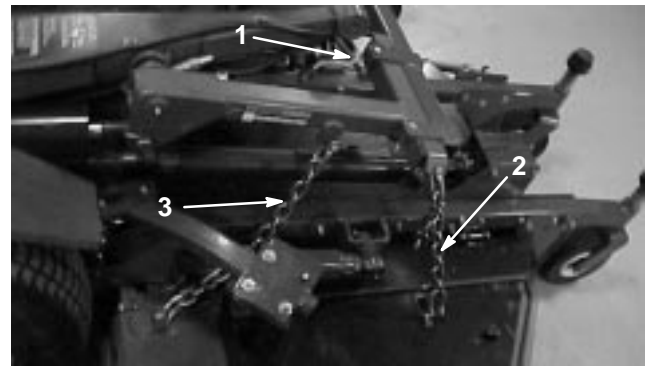

**Figure 13**

1. Drive shaft

## Install Lift Chains

1. Connect lift chains to lift arm and cutting unit chain brackets with (6) shackles, (3/8 x 1-1/2 in.) shackle pins and (1/8 x 3/4 in.) cotter pins. To ensure that cutting unit lifts properly, secure chains to the following links when connecting:
  - Front Left – 8th link
  - Front Right – 8th link
  - Rear – 14th link (All links)
2. Check operation to ensure that all chains lift deck tight against stops when lift arm is raised.

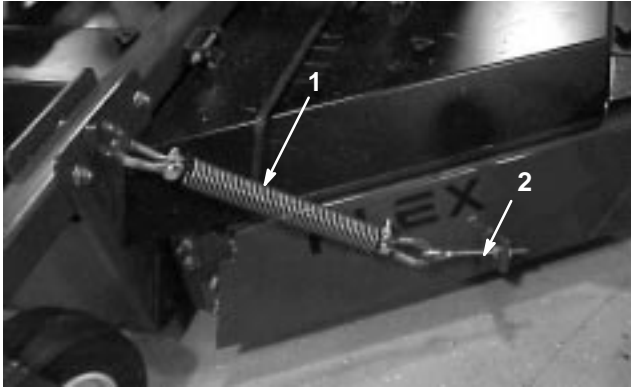

**Figure 14**

- |                           |                    |
|---------------------------|--------------------|
| 1. Front left lift chain  | 3. Rear lift chain |
| 2. Front right lift chain |                    |

## Adjust Counter Balance Spring

1. Tighten nuts on adjusting rod until there is equal weight on castor wheels of left and left center chambers.



**Figure 15**

1. Counterbalance spring
  2. Adjusting rod
- 

## Grease Cutting Unit

Before the cutting unit is operated, it must be greased to ensure proper lubricating characteristics: refer to Lubrication, page 13. Failure to properly grease the cutting unit will result in premature failure of critical parts.

## Install Rear Weight

GROUNDMASTER 300 Series Traction Units comply with ANSI B71.4–1999 Standard when equipped with rear weight. Refer to chart in Traction Unit Operator's Manual to determine combinations of weight required. Order parts from your local Authorized Toro Distributor.

# Before Operating

## Check Lubricant In Gear Box

The gear box is designed to operate on SAE 80–90 wt. gear lube. Although the gear box is shipped with lubricant from the factory, check the level before operating the cutting unit.

1. Position the machine and cutting unit on a level surface.
2. Remove check plug from side of gear box and make sure lubricant is up to bottom of hole. If level of lubricant is low, add enough lubricant to bring it up to bottom of hole.

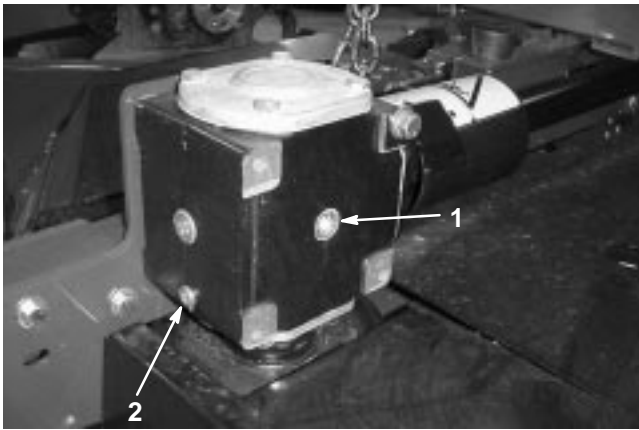

Figure 16

1. Fill/check plug
2. Drain plug

## Adjusting Height-of-cut

The height-of-cut is adjustable from 1 to 4 inches in 1/4 inch increments.

1. Start the engine and raise the cutting unit so height-of-cut can be changed. Stop engine after cutting unit is raised.

## Front Castor Wheels

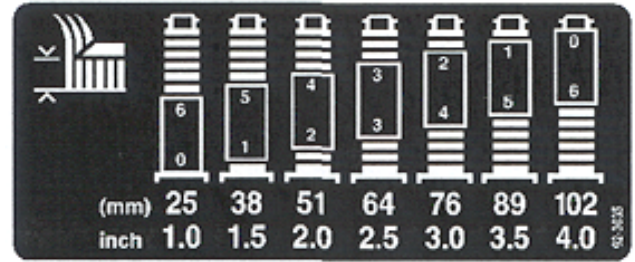

Figure 17

1. Remove H.O.C. cap from spindle shaft and slide spindle out of front castor arm. Slide spacers onto spindle shaft to get desired height-of-cut.

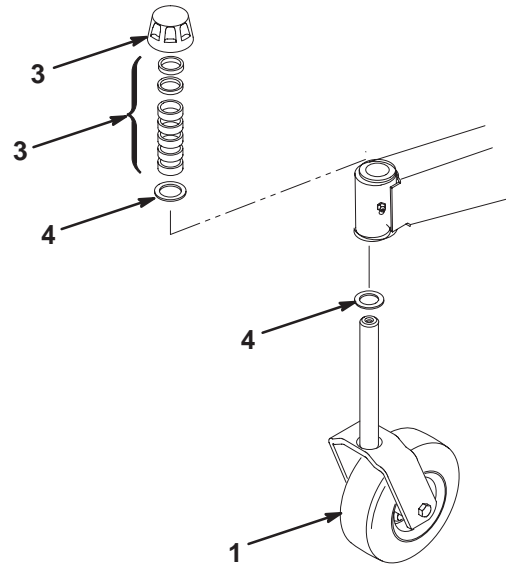

Figure 18

1. Front castor wheel
2. H.O.C. cap
3. Spacer
4. Washer

2. Push castor spindle through front castor arm install remaining spacers onto spindle and install HOC cap to secure assembly.

## Rear Castor Wheels

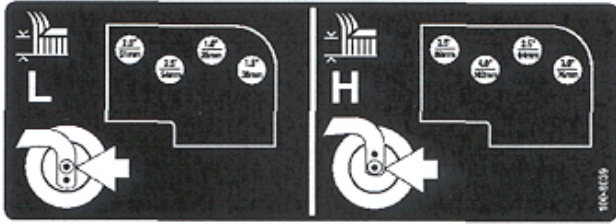

Figure 19

1. Remove hairpin cotter and cotter pin securing rear castor pivot arm to deck bracket.

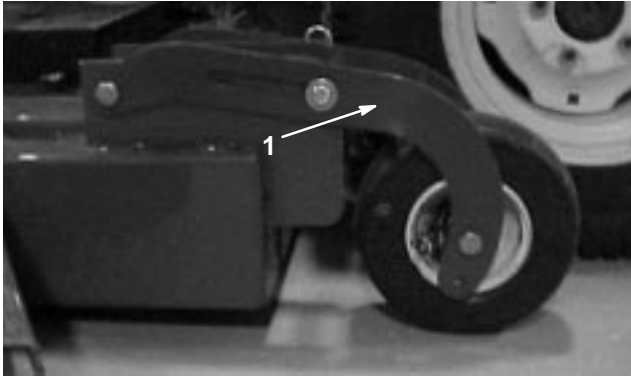

Figure 20

1. Rear castor pivot
- 
2. Align the pivot arm holes with selected height-of-cut bracket holes in the deck frame, install cotter pin and secure with hairpin cotter.

## Rear Deck Chain

1. Remove hair pin cotter and clevis pin securing height-of-cut chain to chamber bracket.
2. Mount height-of-cut chain to desired height-of-cut hole with clevis pin and hair pin cotter.

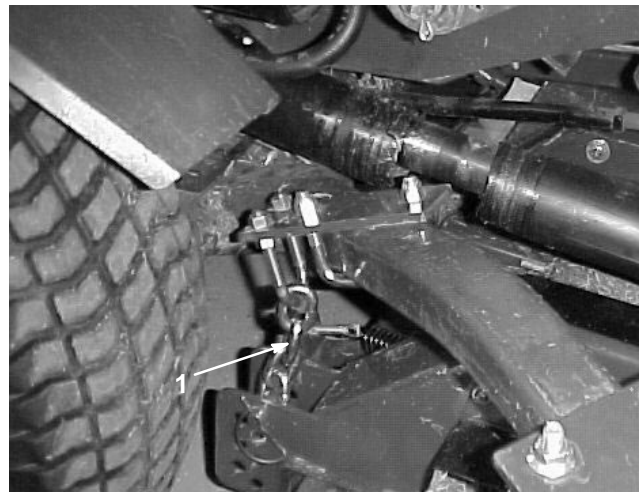

Figure 21

1. H.O.C chain

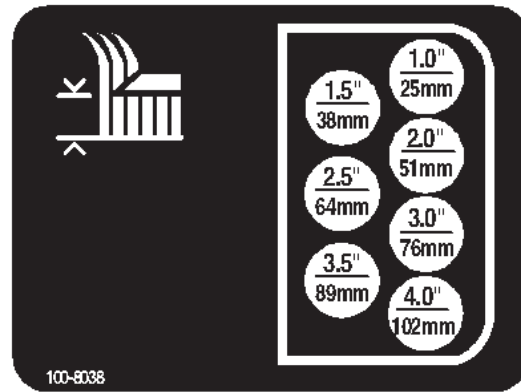

Figure 22

## Check Tire Pressure

Ensure that the air pressure in the front and rear castor wheels is 40 psi (276 kPa).

**Important** Maintain even pressure in all tires to ensure a good quality-of-cut and proper machine performance. **Do not under-inflate.**

## Adjust Skid

Skid, on right side of cutting unit, should be located in upper holes for 1 and 1-1/2 inch heights-of-cut and lower holes for 2 to 4 inch heights-of-cut.

1. Adjust skid by removing flange nuts, positioning as desired and re-installing flange nuts.

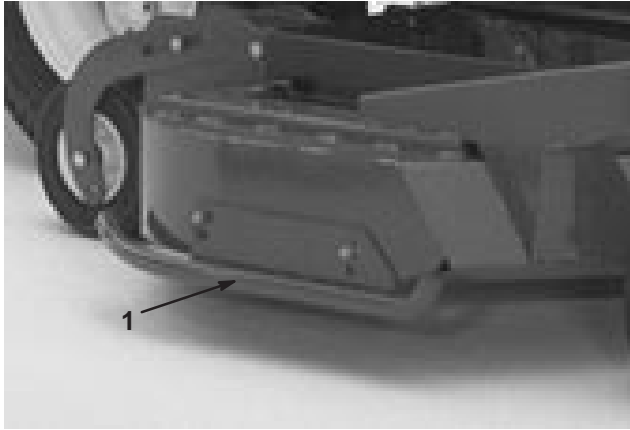

**Figure 23**

1. Skid
- 

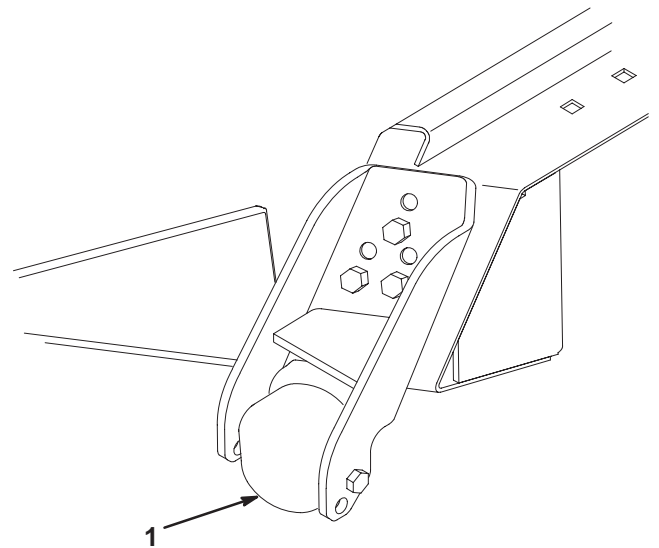

**Figure 24**

1. Roller
- 

## Adjust Rollers

The front anti-scalp rollers and the rear anti-scalp rollers, located on the center deck, should be located in upper holes for 1 and 1-1/2 inch heights-of-cut and lower holes for 2 to 5 inch heights-of-cut. Six rollers are located on the deck, two under the main deck and two on each wing.

1. Adjust anti-scalp rollers by removing screw securing roller shaft to deck, positioning roller as desired, and reinstalling shaft with screw, washers, and nut (Fig. 24).
2. The two outside wing deck rollers can be adjusted at the roller, or the bracket can be repositioned on the deck.

# Operation

## Grass Deflector

**Warning**

The grass deflector (Fig. NO TAG) is a safety device that diverts grass and other foreign objects being discharged downward. **WE STRONGLY RECOMMEND THAT THE DEFLECTOR BE IN ITS NORMAL OPERATING POSITION WHENEVER THE CUTTING UNIT IS ENGAGED. NEVER OPERATE CUTTING UNIT WITH THE DEFLECTOR REMOVED FROM THE CUTTING UNIT OR IT TIED/BLOCKED IN A RAISED POSITION. SINCE THE BLADES COULD THEN THROW DEBRIS A CONSIDERABLE DISTANCE WITH SUFFICIENT FORCE TO CAUSE PERSONAL INJURY OR DAMAGE TO PROPERTY.** If the grass deflector is damaged, repair or replace the affected part(s).

**Note:** The deflector is spring loaded into its downward normal operating position, but the operator can temporarily swing it out of the way to facilitate loading in a trailer or when otherwise necessary.

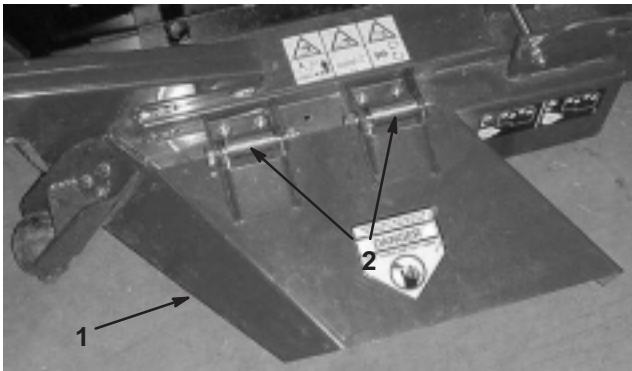

Figure 25

1. Grass deflector

2. Springs

## Operating Tips

- **SELECT THE PROPER HEIGHT-OF-CUT SETTING TO SUIT CONDITIONS** – Remove approximately one inch or no more than 1/3 of the grass blade when cutting. In exceptionally lush and dense grass you may have to raise your height-of-cut setting another notch. When cutting in 1 in. or 1-1/2 in. height-of-cut, add a second washer between rear castor forks and bottom of castor arm housings to increase blade rake.
- **MOWING IN EXTREME CONDITIONS** – Air is required to cut and recut grass clippings in mower housing, so do not set height-of-cut too low or totally surround housing by uncut grass. Always try to have one side of the mower housing free from uncut grass, allowing air to be drawn into housing. When making an initial cut thru center of uncut area, operate machine slower and back up if mower starts to clog.
- **ALWAYS START MOWING WITH SHARP BLADES** – A sharp blade cuts cleanly and without tearing or shredding the grass blades like a dull blade. Tearing and shredding causes the grass to turn brown at the edges which impairs growth and increases susceptibility to diseases. Make sure blade is in good condition and a full sail is present.
- **CHECK CONDITION OF DECK** – Make sure cutting chambers are in good condition. Straighten any bends in chamber components to ensure correct blade tip/chamber clearance.
- **STOPPING** – If forward motion has to be stopped while cutting, a clump of grass clippings may be deposited on lawn. Follow this procedure for stopping while cutting:
  - With deck engaged, move onto a previously cut area.
  - Shift to neutral, move throttle control lever to SLOW position and rotate ignition key to OFF.
- **AFTER OPERATING** – To ensure optimum performance, clean underside of mower housing, especially around inserts (kickers) after each use. If residue is allowed to build up in mower housing and on inserts, cutting performance will decrease.
- **MOW WHEN GRASS IS DRY**–Mow either in the late morning to avoid the dew, which causes grass clumping or in late afternoon to avoid the damage that can be caused by direct sunlight on the sensitive, freshly mowed grass.

# Maintenance

## Greasing The Cutting Unit

The cutting unit must be lubricated regularly. If machine is operated under normal conditions, lubricate castor bearings and bushings with No. 2 general purpose lithium base grease or molybdenum base grease, after every 8 hours of operation or daily, whichever comes first.

1. The cutting unit has bearings and bushings that must be lubricated, and these lubrication points are: front castor spindle bushings (2) (Fig. 26); front castor wheel bearings (4) (Fig. 26); rear castor wheel bearings (2) (Fig. 28); blade spindle bearings (3) (Fig. 28); right and left push arm ball joints (Fig. 28); drive shaft (3) (Fig. 28) idler arm pivots (3) (Fig. 29); and deck pivot pins (4) (Fig. 30)

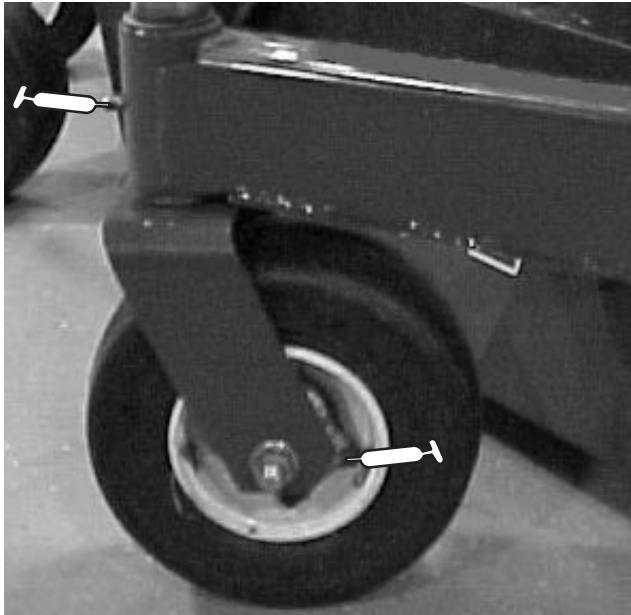

Figure 26

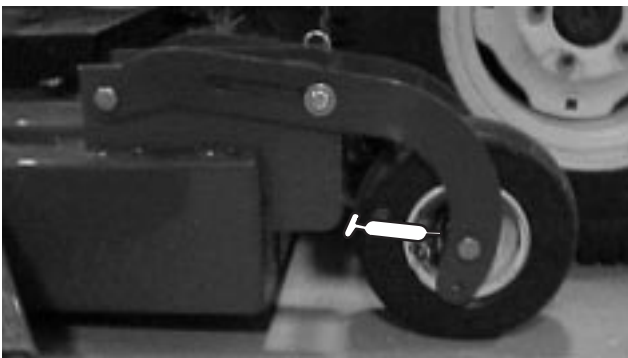

Figure 27

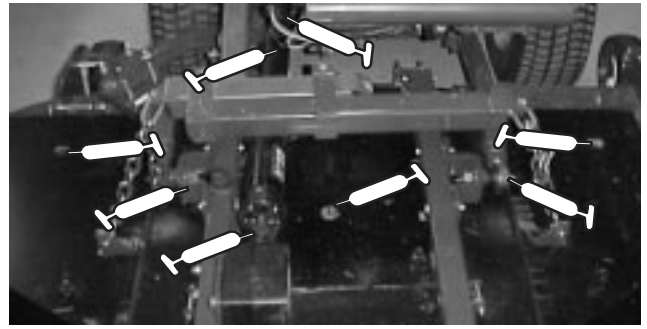

Figure 28

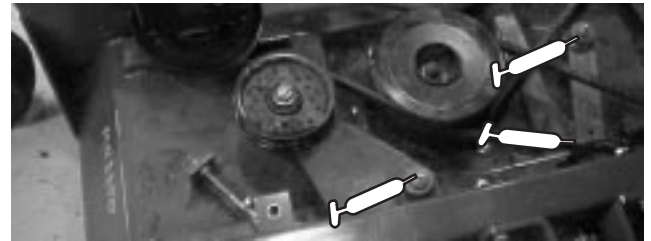

Figure 29

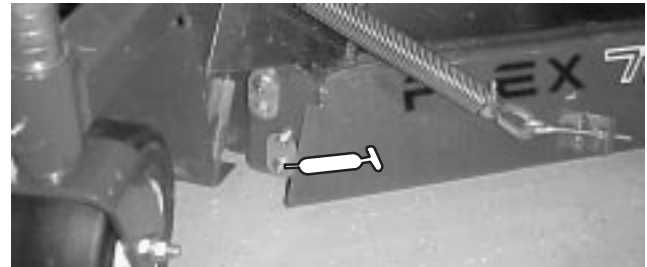

Figure 30

2. Position the machine on a level surface and lower cutting unit. Remove fill/check plug from side of gear box (Fig. 31) and make sure lubricant is up to bottom of hole. If level of lubricant is low, add SAE 80-90 wt. gear lube until level is up to bottom of hole.

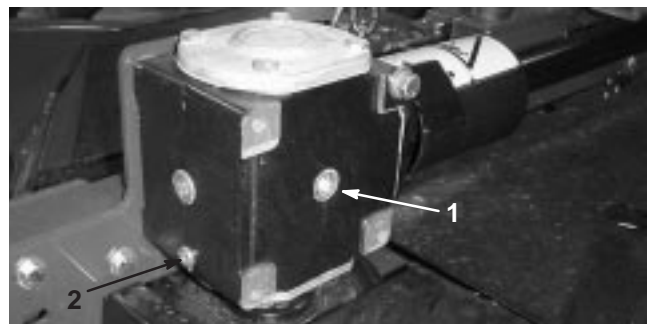
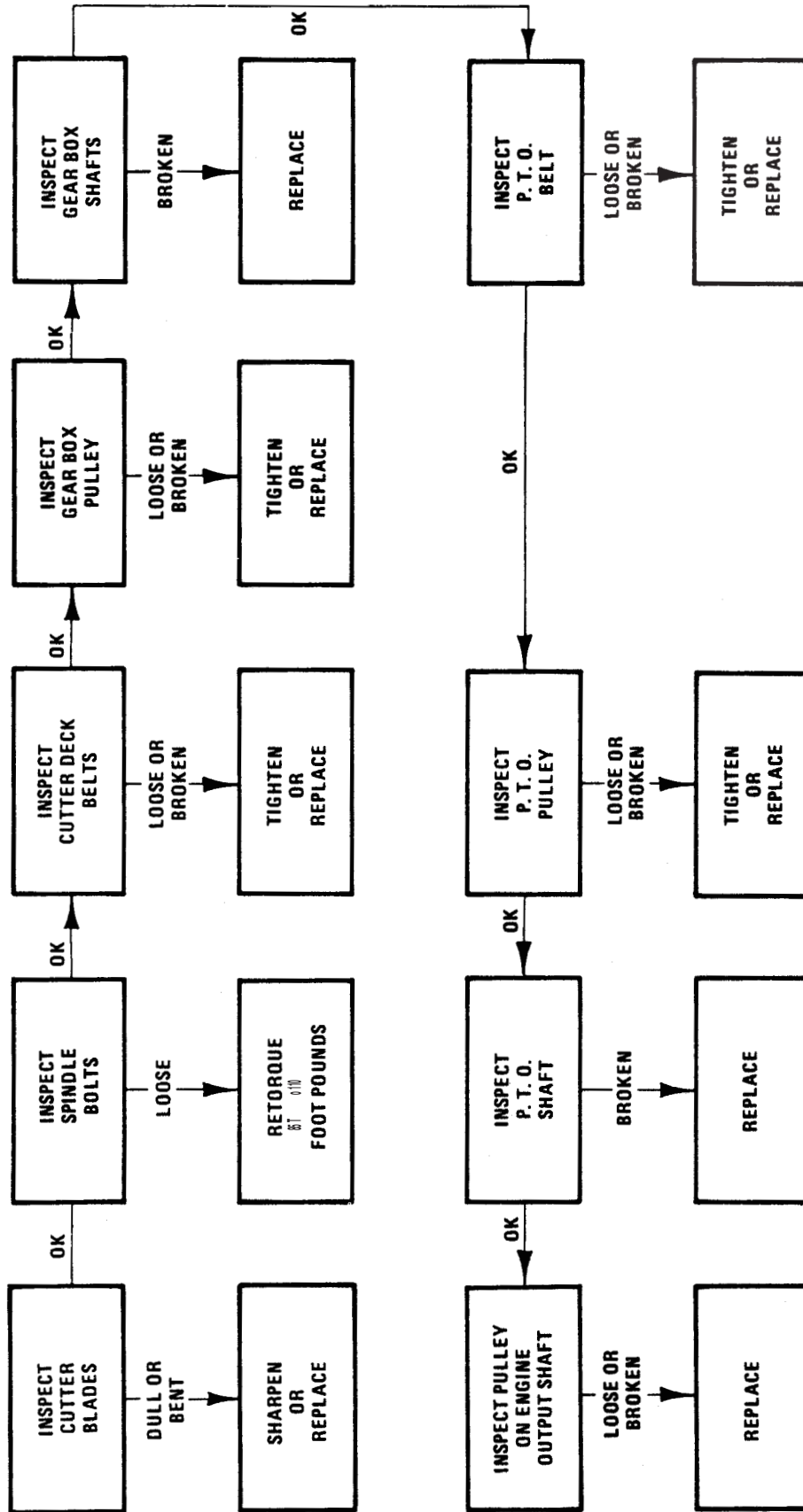

Figure 31

1. Fill/check plug
2. Drain plug

# Trouble Shooting

## UNIT WILL NOT CUT OR CUTS POORLY



## Separating Cutting Unit From Traction Unit

1. Position machine on level surface, lower cutting unit to floor, shut engine off and engage parking brake.
2. Remove self tapping screws securing shield to top of cutting unit and set shield aside.
3. Drive out roll pin securing drive shaft yoke to input shaft of gear box. Loosen capscrews and locknuts and slide yoke off input shaft. If traction unit will be used without the cutting unit, drive roll pin out of yoke at traction unit PTO shaft and remove entire drive shaft from traction unit.



### Danger



**Do not start the engine and engage the PTO lever when PTO shaft is not connected to gear box on cutting unit. If engine is started and PTO shaft is allowed to rotate, serious injury could result.**

4. Disconnect cotter pins and clevis pins securing lift chains to lift arms.



### Warning



**Since the right hand push arm is spring loaded to about 100 pounds, a helper is needed to push the arm down. Sudden release of the push arm could cause injury.**

5. Have a helper push down on the right push arm while you remove the flange head capscrews and locknuts securing the ball joint mount to castor arm on cutting unit. Now the helper can carefully allow push arm to move upward, which will gradually release the 100 pounds of spring load.
6. Have a helper push down on the left push arm while you remove the flange head capscrews and locknuts securing the ball joint mount to castor arm on cutting unit. Now the helper can carefully allow push arm to move upward, which will gradually release the 150 pounds of spring load.
7. Roll the cutting unit away from the traction unit.

## Mounting Cutting Unit To Traction Unit

1. Position machine on a level surface and shut engine off.
2. Move cutting unit into position in front of traction unit.



### Warning



**Since the left hand push arm is spring loaded to about 100 pounds, a helper is needed to push the arm down. Sudden release of the push arm could cause injury.**

3. Have a helper carefully push down on the right push arm until holes in ball joint mount line up with holes in castor arm.
4. Secure ball joint mount to castor arm with flange head capscrews and flange nuts. Capscrew heads to be positioned to inside of castor arm.
5. Have a helper carefully push down on the left push arm until holes in ball joint mount line up with holes in castor arm. Immediately slide a 4 x 4 in. block of wood between top of push arm and underside of chassis



### Warning



**Make sure the wooden block does not slip out accidentally. Sudden release of the push arm could cause injury.**

6. Secure ball joint mount to castor arm with flange head capscrews and flange nuts. capscrew heads to be positioned to inside of castor arm. Chain bracket to be mounted in forward set of holes.
7. Carefully remove wood block holding push arm down.
8. Line up holes in yoke and input shaft of gear box. Slide yoke onto shaft and secure together with a roll pin and 2 capscrews (5/16 x 1-3/4 in.) and locknuts (5/16 in.).

## Adjusting Drive Belts

The blade drive belts are tensioned by the spring loaded idlers, are very durable. However, after many hours of use, the belts will stretch and will need adjusting.

1. Lower cutting unit to the shop floor. Remove belt covers from top of cutting unit and set covers aside.
2. Adjust spring tensioning rods until 10 lb. tension is achieved for side belts and 30 lb. tension for center gear box belt.



**Figure 32**

1. Spring tensioning rod (3)

## Replacing Drive Belts

The blade drive belts, tensioned by the spring loaded idlers, are very durable. However, after many hours of use, the belts will show signs of wear. Signs of a worn belt are: squealing when belt is rotating, blades slipping when cutting grass, frayed edges, burn marks, and cracks. Replace the belt if any of these conditions are evident.

1. Lower cutting unit to the shop floor. Remove belt covers from top of cutting unit and set covers aside.
2. To replace gear box belt, loosen spring tension rod and remove belt. Retention new belt to 30 lb. Refer to Figure 33 for belt routing.

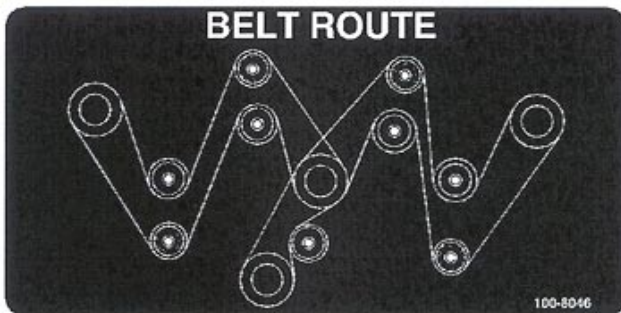

**Figure 33**

3. To replace wing belts, loosen spring tension rod and remove gear box belt.
4. Pull spring loaded idler pulley away from belt, with hand, to relieve belt tension and remove belt. Retention new belts to 10 lb. Refer to Figure 33 for belt routing.
5. Install belt covers.

## Servicing Front Bushings In Castor Arms

The castor arms have bushings pressed into the top and bottom of the tube and after many hours of operation, the bushings will wear. To check the bushings, move castor fork back and forth and from side to side. If castor spindle is loose inside the bushings, bushings are worn and must be replaced.

1. Raise cutting unit so wheels are off floor and block it so it cannot fall accidentally.
2. Remove tensioning cap, spacer(s) and thrust washer from top of castor spindle.
3. Pull castor spindle out of mounting tube. Allow thrust washer and spacer(s) to remain on bottom of spindle.
4. Insert pin punch into top or bottom of mounting tube and drive bushing out of tube. Also drive other bushing out of tube. Clean inside of tubes to remove dirt.

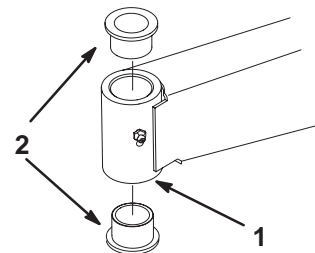

**Figure 34**

1. Front castor arm tube

2. Bushings

5. Apply grease to inside and outside of new bushings. Using a hammer and flat plate, drive bushings into mounting tube.
6. Inspect castor spindle for wear and replace it if damaged.
7. Push castor spindle through bushings and mounting tube. Slide thrust washer and spacer(s) onto spindle. Install tensioning cap on castor spindle to retain all parts in place.

## Servicing Castor Wheels And Bearings

The castor wheel rotates on a high-quality roller bearing and is supported by a spanner bushing. Even after many hours of use, provided that the bearing was kept well-lubricated, bearing wear will be minimal. However, failure to keep bearing lubricated will cause rapid wear. A wobbly castor wheel usually indicates a worn bearing.

1. Remove locknut from capscrew holding castor wheel assembly between castor fork. Grasp castor wheel and slide capscrew out of fork.
2. Pull spanner bushing out of wheel hub.

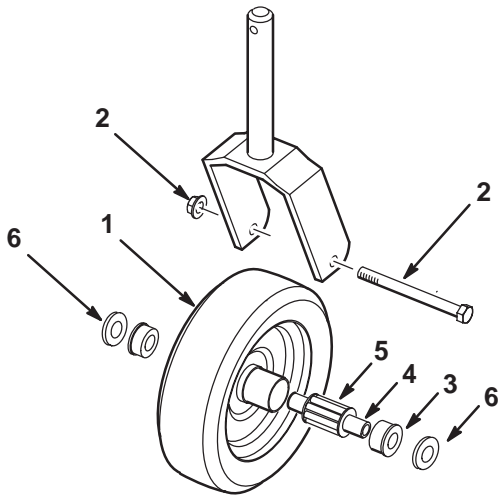

**Figure 35**

- |                       |                    |
|-----------------------|--------------------|
| 1. Castor wheel       | 4. Spanner bushing |
| 2. Capscrew & locknut | 5. Roller bearing  |
| 3. Bushing (2)        | 6. Washer          |

3. Remove bushing from wheel hub and allow bearing to fall out. Remove bushing from opposite side of wheel hub.
4. Check the bearing, spanner and inside of wheel hub for wear. Replace defective parts.
5. To assemble the castor wheel, push bushing into wheel hub. Slide bearing into wheel hub. Push other bushing into open end of wheel hub to captivate the bearing inside the wheel hub.
6. Carefully slide spanner through the bushings and the wheel hub.
7. Install castor wheel assembly between castor fork and secure in place with capscrew, washers and locknut.
8. Lubricate castor wheel bearing through grease fitting, using No. 2 general purpose lithium base grease.

## Replacing Grass Deflector

1. Position machine on a level surface, raise cutting unit, engage parking brake, be sure traction pedal is in neutral position, PTO lever in OFF position, shut engine OFF, and remove key from switch. Block cutting unit to prevent it from falling accidentally.
2. Remove two capscrews, locknuts, and springs securing deflector mounts to pivot brackets.
3. To remove the pivot brackets, remove carriage bolts and nuts.
4. Reinstall pivot brackets on top of discharge opening with carriage bolts and nuts. Head of carriage bolts must be on inside of cutting unit.
5. Position deflector mounts on pivot brackets and secure parts together with capscrews, locknuts and springs. Both locknuts must face each other. Tighten locknuts until they are flush against deflector pivots.

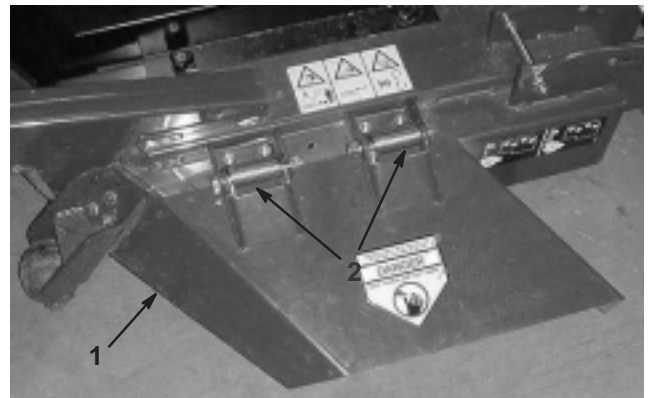

**Figure 36**

- |                    |                  |
|--------------------|------------------|
| 1. Grass deflector | 2. Pivot springs |
|--------------------|------------------|

6. Lift deflector and allow it to drop to check spring tension. Deflector must be held firmly in full downward position by spring tension. Correct if necessary.

## Removing Cutter Blade

The blade must be replaced if a solid object is hit, the blade is out-of-balance or if the blade is bent. Always use genuine Toro replacement blades to be sure of safety and optimum performance. Never use replacement blades made by other manufacturers because they could be dangerous.

1. Raise cutting unit to highest position, shut the engine off and engage the parking brake. Block cutting unit to prevent it from falling accidentally.
2. Grasp end of blade using a rag or thickly padded glove. Remove blade bolt, lock washer, anti-scalp cup, and blade from spindle shaft.

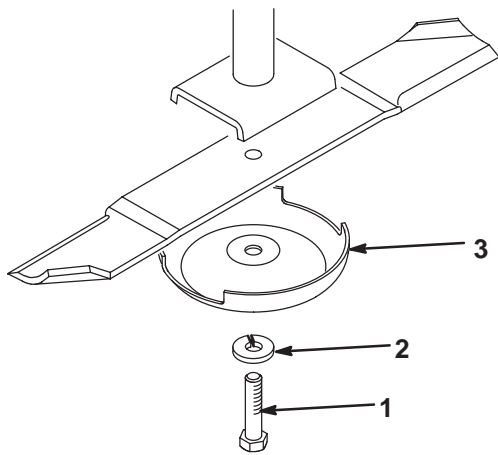

Figure 37

1. Blade bolt
2. Lockwasher
3. Anti-scalp cup

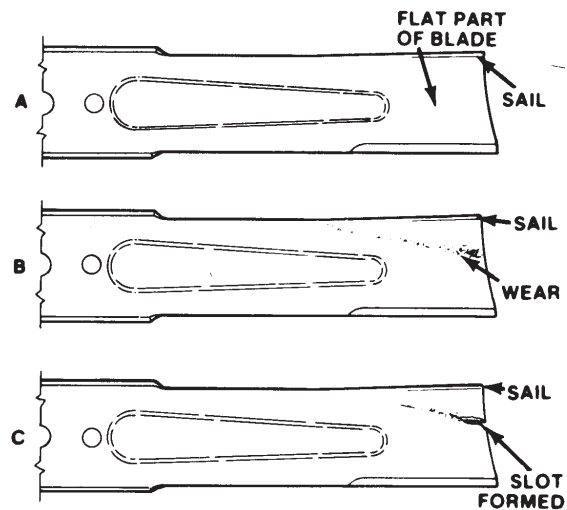

Figure 38

3. Install blade—sail facing toward cutting unit with anti-scalp cup, lock washer, and blade bolt. Tighten blade bolt to 85–110 ft.-lb.

**Warning**

**Do not try to straighten a blade that is bent, and never weld a broken or cracked blade. Always use a new blade to ensure continued safety certification of the product.**

3. Inspect cutting edges of all blades. Sharpen the cutting edges if they are dull or nicked. Sharpen only the top of the cutting edge and maintain the original cutting angle to make sure of sharpness (Fig. 39). The blade will remain balanced if same amount of metal is removed from both cutting edges.

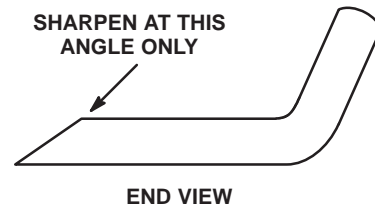

Figure 39

## Inspecting And Sharpening Blade

1. Raise cutting unit to highest position, shut the engine off and engage the parking brake. Block cutting unit to prevent it from falling accidentally.
2. Examine cutting ends of the blade carefully, especially where the flat and curved parts of the blade meet (Fig. 38-A). Since sand and abrasive material can wear away the metal that connects the flat and curved parts of the blade, check the blade before using the machine. If wear is noticed (Fig. 38-B), replace the blade: refer to Removing Cutter Blade.

**Danger**

**If blade is allowed to wear, a slot will form between the sail and flat part of the blade (Fig. 38-C). Eventually a piece of the blade may break off and be thrown from under the housing, possibly resulting in serious injury to yourself or bystander.**

4. To check blade for being straight and parallel, lay blade on a level surface and check its ends. Ends of blade must be slightly lower than the center, and cutting edge must be lower than the heel of the blade. This blade will produce good quality of cut and require minimal power from the engine. By contrast a blade that is higher at the ends than the center, or if cutting edge is higher than the heel, the blade is bent or warped and must be replaced.
5. Install blade—sail facing toward cutting unit with anti-scalp cup, lock washer, and blade bolt. Tighten blade bolt to 85–110 ft.-lb.

## Correcting Cutting Unit Mismatch

If there is mismatch between the blades, the grass will appear streaked when it is cut. This problem can be corrected by making sure the blades are straight and all blades are cutting on the same plane.

1. Using a 3 foot long carpenters level, find a level surface on the shop floor.
2. Raise height-of-cut to the highest position: refer to Adjusting Height-of-Cut.
3. Lower cutting unit onto flat surface. Remove covers from top of cutting unit.
4. Unhook spring from idler arm bracket to release belt tension.
5. Rotate blades until the ends face forward and backward. Measure from floor to front tip of cutting edge and remember this dimension. Then rotate same blade so opposite end is forward and measure again. The difference between dimensions must not exceed 1/8 of an inch. If dimension exceeds 1/8 of an inch, replace the blade because it is bent. Make sure to measure all blades.
6. Compare measurements of outer blades with the center blade. Center blade must not be more than 3/8 of an inch lower than the outer blades. If center blade is more than 3/8 of an inch lower than the outer blades. proceed to step 7 and add shims between spindle housing and bottom of cutting unit.
7. Remove capscrews, flatwashers, lockwashers and nuts from outer spindle in the area where shims must be added. To raise or lower the blade, add a shim, Part No. 3256-24, between spindle housing and bottom of cutting unit. Continue to check alignment of blades and add shims until tips of blades are within the required dimension.

**Important** Do not use more than three shims at any one hole location. Use decreasing numbers of shims in adjacent holes if more than one shim is added to any one hole location.

8. Hook spring onto idler arm bracket. Reinstall belt covers.



# The Toro General Commercial Products Warranty

## A Two-Year Limited Warranty

### Conditions and Products Covered

The Toro Company and its affiliate, Toro Warranty Company, pursuant to an agreement between them, jointly warrant your 1996 or newer Toro Commercial Product ("Product") purchased after January 1, 1997, to be free from defects in materials or workmanship for two years or 1500 operational hours\*, whichever occurs first. Where a warrantable condition exists, we will repair the Product at no cost to you including diagnosis, labor, parts, and transportation. This warranty begins on the date the Product is delivered to the original retail purchaser.

\* Product equipped with hour meter

### Instructions for Obtaining Warranty Service

You are responsible for notifying the Commercial Products Distributor or Authorized Commercial Products Dealer from whom you purchased the Product as soon as you believe a warrantable condition exists.

If you need help locating a Commercial Products Distributor or Authorized Dealer, or if you have questions regarding your warranty rights or responsibilities, you may contact us at:

Toro Commercial Products Service Department  
Toro Warranty Company  
8111 Lyndale Avenue South  
Bloomington, MN 55420-1196  
952-888-8801 or 800-982-2740  
E-mail: commercial.service@toro.com

### Owner Responsibilities

As the Product owner, you are responsible for required maintenance and adjustments stated in your operator's manual. Failure to perform required maintenance and adjustments can be grounds for disallowing a warranty claim.

### Items and Conditions Not Covered

Not all product failures or malfunctions that occur during the warranty period are defects in materials or workmanship. This express warranty does not cover the following:

- Product failures which result from the use of non-Toro replacement parts, or from installation and use of add-on, modified, or unapproved accessories
- Product failures which result from failure to perform required maintenance and/or adjustments
- Product failures which result from operating the Product in an abusive, negligent or reckless manner
- Parts subject to consumption through use unless found to be defective. Examples of parts which are consumed, or used up, during normal Product operation include, but are not limited to, blades, reels, bedknives, tines, spark plugs, castor wheels, tires, filters, belts, etc.

### Countries Other than the United States or Canada

Customers who have purchased Toro products exported from the United States or Canada should contact their Toro Distributor (Dealer) to obtain guarantee policies for your country, province, or state. If for any reason you are dissatisfied with your Distributor's service or have difficulty obtaining guarantee information, contact the Toro importer. If all other remedies fail, you may contact us at Toro Warranty Company.

- Failures caused by outside influence. Items considered to be outside influence include, but are not limited to, weather, storage practices, contamination, use of unapproved coolants, lubricants, additives, or chemicals, etc.
- Normal "wear and tear" items. Normal "wear and tear" includes, but is not limited to, damage to seats due to wear or abrasion, worn painted surfaces, scratched decals or windows, etc.

### Parts

Parts scheduled for replacement as required maintenance are warranted for the period of time up to the scheduled replacement time for that part.

Parts replaced under this warranty become the property of Toro. Toro will make the final decision whether to repair any existing part or assembly or replace it. Toro may use factory remanufactured parts rather than new parts for some warranty repairs.

### General Conditions

Repair by an Authorized Toro Distributor or Dealer is your sole remedy under this warranty.

**Neither The Toro Company nor Toro Warranty Company is liable for indirect, incidental or consequential damages in connection with the use of the Toro Products covered by this warranty, including any cost or expense of providing substitute equipment or service during reasonable periods of malfunction or non-use pending completion of repairs under this warranty. Except for the Emissions warranty referenced below, if applicable, there is no other express warranty. All implied warranties of merchantability and fitness for use are limited to the duration of this express warranty.**

Some states do not allow exclusions of incidental or consequential damages, or limitations on how long an implied warranty lasts, so the above exclusions and limitations may not apply to you.

This warranty gives you specific legal rights, and you may also have other rights which vary from state to state.

**Note regarding engine warranty:** The Emissions Control System on your Product may be covered by a separate warranty meeting requirements established by the U.S. Environmental Protection Agency (EPA) and/or the California Air Resources Board (CARB). The hour limitations set forth above do not apply to the Emissions Control System Warranty. Refer to the Engine Emission Control Warranty Statement printed in your operator's manual or contained in the engine manufacturer's documentation for details.