



## Z287L

### Z Master<sup>®</sup> with 62in SFS Side Discharge Mower

Model No. 74213—22000001 and Up

## Parts Catalog

---

### Ordering Replacement Parts

To order replacement parts, please supply: the part number, the quantity, and the description of each part desired.

### Understanding Reference Numbers

Each identified part in an illustration has a reference number. The reference number for a part also appears in the parts list, along with other information about the part.

This catalog uses two special reference number formats, one to indicate parts in a service assembly and another to indicate the quantity of a given part in an illustration.

### Service Assembly Reference Numbers

Parts in service assemblies have reference numbers in the form **a:b**. The **a** represents the reference number of the entire service assembly and the **b** represents a sequential number unique to each part within the service assembly.

For example, a wheel assembly might be identified by reference number **6**, the tire by **6:1**, the valve by **6:2**, and the wheel by **6:3**. When you order the assembly identified by reference number **6**, you receive all parts identified by reference numbers **6:1**, **6:2**, and **6:3**. However, you may also order any part individually.

Reference numbers of this type appear in illustrations and in part lists.

### Reference Numbers Indicating Quantity

In an illustration, if a reference number indicates more than one part, the reference number has the form **nX y**. The **n** represents the quantity of the part, the **X** is the multiplication symbol, and the **y** represents the reference number.

For example, in an illustration, the reference number **2X 37** means that two of the parts identified by reference number **37** are indicated.

## Contents

<b>Description</b>	<b>Page</b>	<b>Description</b>	<b>Page</b>
Front Frame Assembly .....	4	Piston/Crankshaft (Kawasaki FD750D-AS03) .....	26
Caster and Wheel Assembly .....	5	Valve/Camshaft (Kawasaki FD750D-AS03) .....	27
Rear Frame and Wheel Assembly .....	6	Lubrication Equipment (Kawasaki FD750D-AS03) .....	28
Brake and Wheel Hub Assembly .....	7	Cooling Equipment (Kawasaki FD750D-AS03) .....	29
Steering Control Assembly .....	8	Electric Equipment (Kawasaki FD750D-AS03) .....	30
Hydraulic System Assembly .....	9	Control Equipment (Kawasaki FD750D-AS03) .....	31
Seat Assembly .....	11	Carburetor (Kawasaki FD750D-AS03) .....	32
Frame and Deck Assembly .....	12	Air-Filter/Muffler (Kawasaki FD750D-AS03) .....	33
Idler Assembly .....	13	Fuel-Tank/Fuel-Valve (Kawasaki FD750D-AS03) .....	34
Stand Assembly .....	14	Starter (Kawasaki FD750D-AS03) .....	35
Engine Assembly .....	15		
Engine Assembly (Continued) .....	16		
Hood Assembly .....	17		
Cooling Mounting Frame Assembly .....	18		
Tank and Fuel Line Assembly .....	19		
Electrical System Assembly .....	20		
Deck, Deflector and Roller Assembly .....	21		
Spindle and Pulley Assembly .....	22		
Belt and Idler Arm Assembly .....	23		
Electrical Schematic .....	24		
Cylinder/Crankcase (Kawasaki FD750D-AS03) .....	25		

## Accessories

<b>Description</b>	<b>Model / Part No.</b>	<b>Description</b>	<b>Model / Part No.</b>
Striping Kit .....	30163	Atomic Blade .....	104-1303
Hitch Kit .....	99-8925	Z Recycler Kit (62in) .....	100-9600

## Part Description Abbreviations

Part descriptions in this catalog may include the following abbreviations.

<b>Abbreviation</b>	<b>Meaning</b>	<b>Abbreviation</b>	<b>Meaning</b>
AR .....	as required	HWHTF .....	hex washer head thread forming
ASM .....	assembly	INC .....	incorporated
CARR .....	carriage	LH .....	left hand
DEG .....	degrees	NI .....	nylon insert
FH .....	flat head	PPH .....	Phillips pan head
GA .....	gauge	PTH .....	Phillips truss head
HF .....	hex flange	PTO .....	power take off
HH .....	hex head	RH .....	right hand
HHF .....	hex head flange	SFH .....	slotted fillister head
HLH .....	hex lag head	SHH .....	slotted hex head
HJ .....	hex jam	SQH .....	square head
HOC .....	height-of-cut	SHWH .....	slotted hex washer head
HS .....	hex socket	SPH .....	slotted pan head
HSBH .....	hex socket button head	SRH .....	slotted round head
HSFH .....	hex socket flat head	STD .....	standard
HSH .....	hex socket head	TAP .....	self tapping
HWH .....	hex washer head	TTH .....	Torx truss head

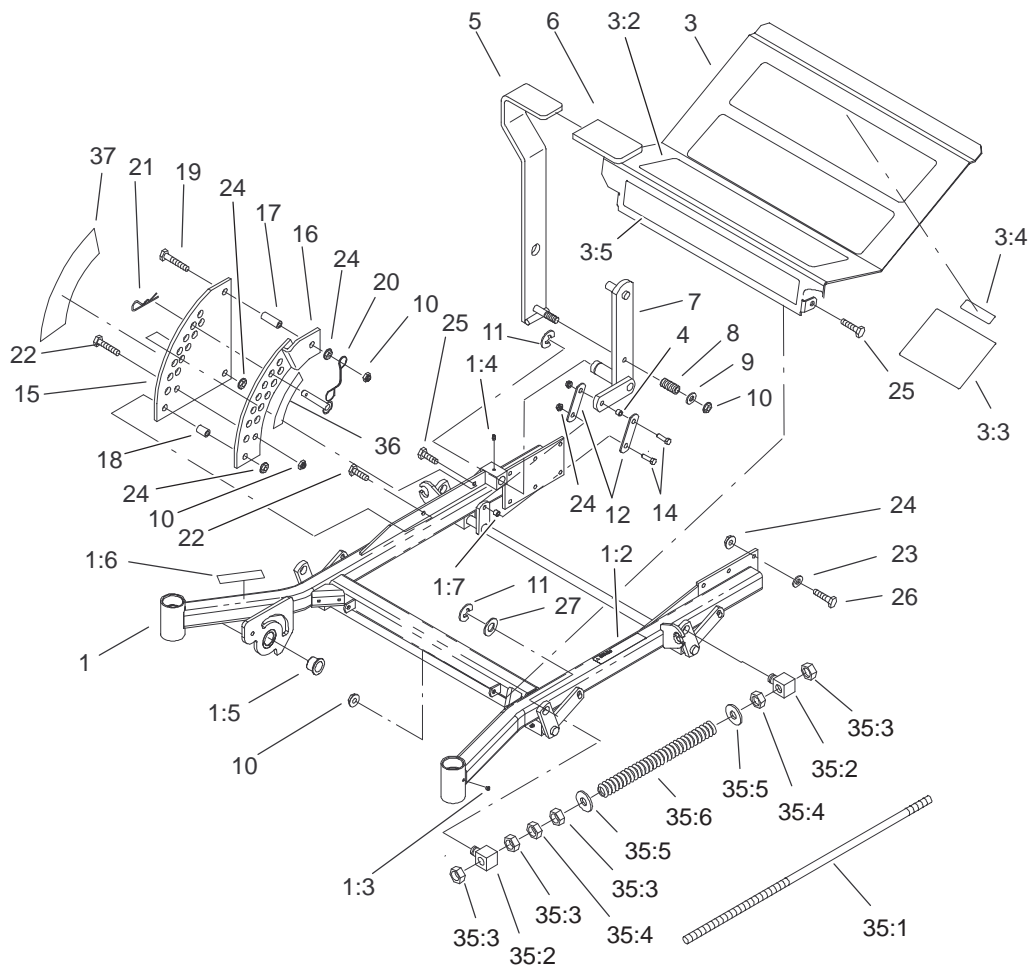

Sheet No.:2

## Front Frame Assembly

Ref. No.	Part No.	Qty.	Description
1	104-5132	1	Frame ASM
1:2	1-633818	1	Decal-Warning
1:3	1-811010	2	Plug
1:4	302-19	5	Fitting-Grease
1:5	94-1291	2	Bushing-Special
1:6	104-7759	1	Decal-Warning
1:7	103-1918	1	Bushing
3	100-6509	1	Floorpan ASM
3:2	1-633553	3	Pad-Antiskid
3:3	1-633766	1	Decal-Check
3:4	98-5954	1	Decal-Missing, Cover
3:5	1-633737	1	Decal-Z-Master
4	103-1918	1	Bushing
5	103-2083-03	1	Lever-Lift
6	1-633295	1	Grip-Lever, Lift
7	103-2064-03	1	Arm-Lift, Deck
8	1-633325	1	Spring-Compression
9	3256-24	1	Washer-Flat
10	3296-39	5	Nut-Lock, NI
11	32151-103	5	Ring-Snap
12	1-633068	2	Arm-Lift, Deck
14	323-29	2	Screw-HH
15	1-633889-01	1	Plate-Lift, Deck
16	1-632899-01	1	Plate-Lift, Deck
17	1-633082	1	Bushing-Lever, Lift
18	1-633080	1	Bushing-Lever, Lift

Ref. No.	Part No.	Qty.	Description
19	323-13	1	Screw-HH
20	1-633097	1	Pin-Hitch W/Lanyard
21	1-806005	1	Pin-Hair
22	323-9	2	Screw-HH
23	98-5975	12	Washer-Belleville
24	3290-357	17	Nut-HHF
25	323-6	3	Screw-HH
26	323-7	12	Screw-HH
27	3256-29	4	Washer-Flat
☆35		2	Front Frame Spring ASM
35:1	1-633096	1	Rod-Lift, Deck
35:2	1-633441	2	Swivel-Deck Mount, Rear
35:3	3217-11	4	Nut-Hex
35:4	3218-6	2	Nut-Jam
35:5	3256-7	2	Washer-Flat
35:6	1-633064	1	Spring-Support, Deck
36	1-633706	1	Decal-Height, Deck
37	1-633345	1	Decal-Height, Deck

☆ Not serviced separately

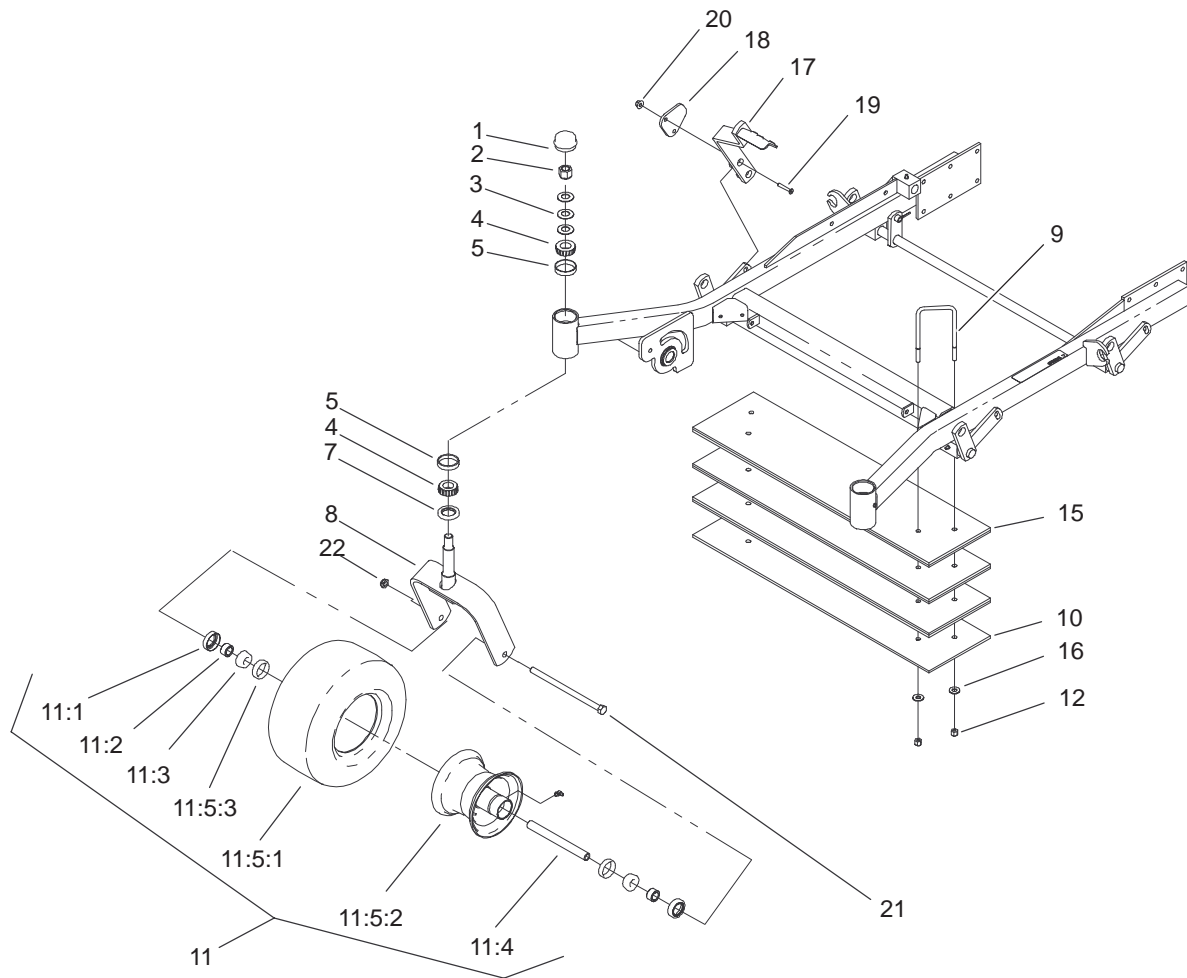

Sheet No.:3

### Caster and Wheel Assembly

Ref. No.	Part No.	Qty.	Description
1	1-543513	2	Cap-Grease
2	3296-51	2	Nut-Lock, NI
3	1-633508	6	Washer-Bellville
4	254-94	4	Bearing-Cone, Taper
5	254-72	4	Bearing-Cup, Tapered
7	1-543511	2	Seal-Grease
8	103-1474-01	2	Fork-Caster
9	100-2339	2	U-Bolt
10	100-2333-01	1	Bar - Weight
11	1-644251	2	Caster Wheel ASM
11:1	1-633580	2	Seal-Bearing
11:2	1-633581	2	Spacer-Bearing
11:3	1-633585	2	Bearing-Cone, Taper
11:4	1-633959	1	Spacer-Caster, Front
☆ 11:5		1	Wheel & Tire ASM
11:5:1	1-523009	1	Tire
11:5:2	1-633987	1	Wheel
11:5:3	1-633584	2	Bearing-Cup
12	3296-39	4	Nut-Lock, NI
15	99-4646-01	3	Weight Bar ASM
16	3256-4	4	Washer-Flat
17	100-4333-01	1	Lever-Lift, Deck
18	1-643220-01	1	Strap
19	3289-7	2	Screw
20	32128-20	2	Nut-HF

Ref. No.	Part No.	Qty.	Description
21	325-39	2	Screw-HH
22	3296-45	2	Nut-Lock, NI

☆ Not serviced separately

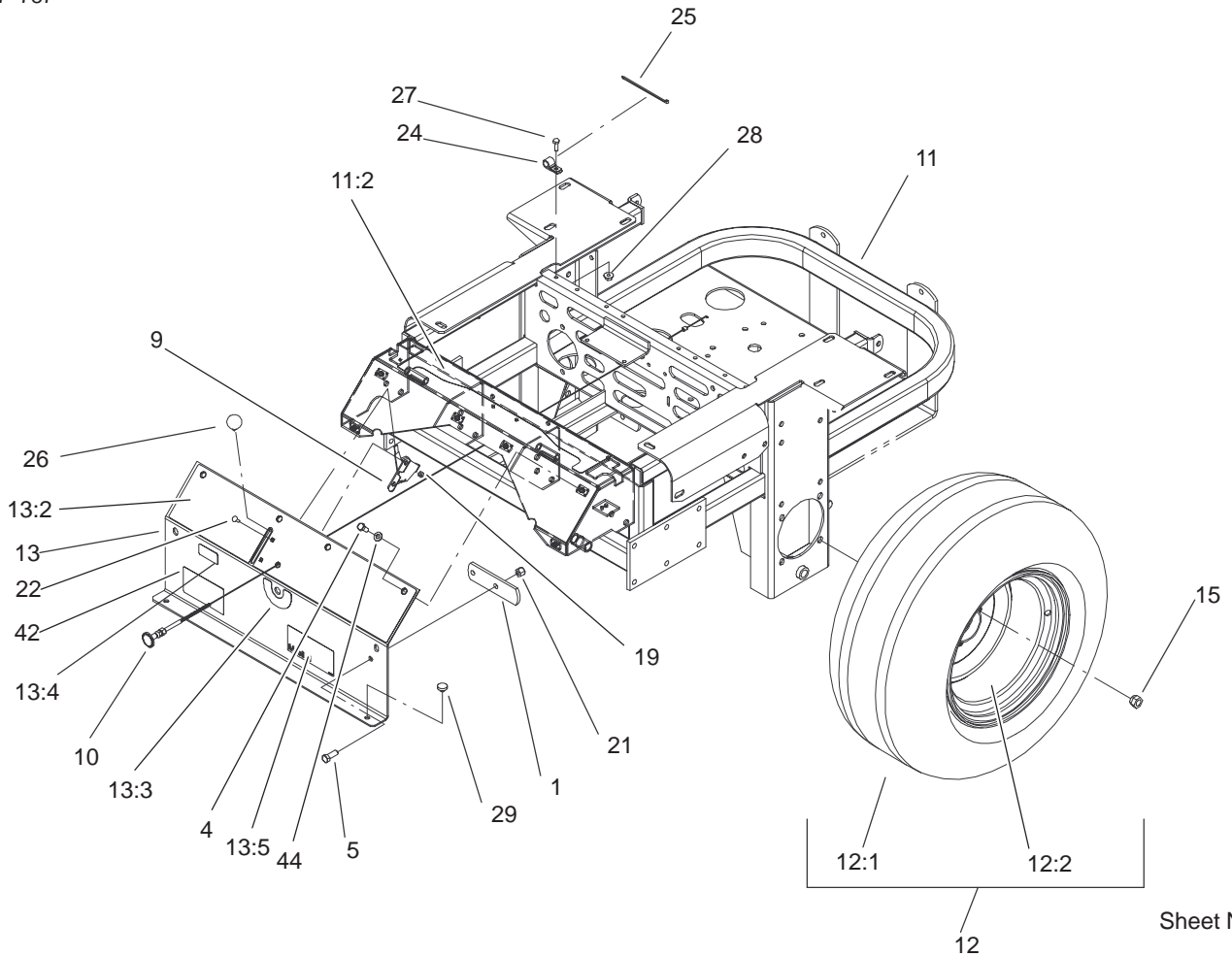

Sheet No.:4

## Rear Frame and Wheel Assembly

Ref. No.	Part No.	Qty.	Description
1	1-633964-03	1	Stop-Brake, Park
4	322-3	6	Screw-HH
5	323-6	2	Screw-HH
9	1-633696	1	Cable-Throttle
10	1-603336	1	Control-Choke
11	105-6120	1	Rear Frame ASM
11:2	103-2433	1	Decal,Top Console
12	1-633970	2	Wheel & Tire ASM
12:1	1-633993	1	Tire
12:2	1-633992	1	Wheel
13	99-4623	1	Console ASM
13:2	100-4311	1	Decal-Panel, Control
13:3	103-0262	1	Decal-Valve, Fuel
13:4	98-4387	1	Decal-Protection, Ear
13:5	104-8172	1	Decal-Mobil 1
15	242-50	8	Nut-Lug
19	3296-2	2	Nut-Lock
21	3296-39	2	Nut-Lock, NI
22	1-807513	2	Bolt-CARR
24	1-513762	1	Clip-Loom
25	1-303335	1	Tie-Plastic
26	1-513592	1	Knob-Ball
27	321-4	1	Screw-HH
28	32128-33	1	Nut-HF
29	1-513658	2	Bumper-Catcher, Grass

Ref. No.	Part No.	Qty.	Description
42	104-7787	1	Decal - Z2871
44	3256-23	6	Washer-Flat

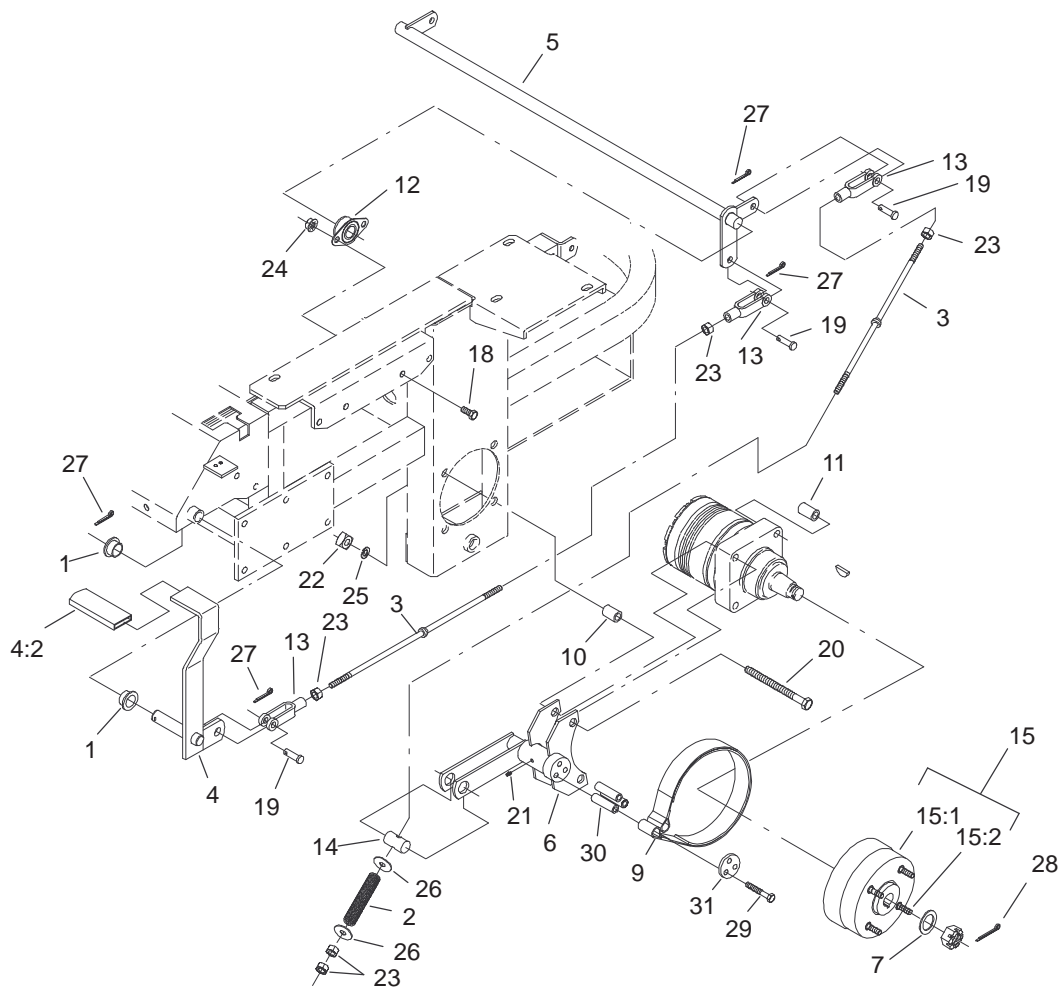

Sheet No.:5

## Brake and Wheel Hub Assembly

Ref. No.	Part No.	Qty.	Description
1	1-513140	2	Bearing-Control
2	1-633454	2	Spring-Brake
3	1-633477	3	Rod-Brake
4	1-634500	1	Brake Lever ASM
4:2	1-633268	1	Grip-Lever, Brake
5	1-632217-03	1	Shaft-Brake
6	103-0352-03	2	Bracket-Brake
7	1-523157	2	Washer-Spacer
9	103-0355	2	Band-Brake
10	1-633380	4	Spacer-Wheel, Short
11	1-633382	4	Spacer-Wheel, Long
12	1-633102	2	Bearing-Flange, Side
13	1-633131	4	Yoke-Linkage, Brake
14	1-633144	2	Pin-Trunion
15	103-0590	2	Hub-Wheel
15:1	103-0589	1	Hub-Wheel
15:2	1-633926	4	Stud-Wheel
18	323-4	4	Screw-HH
19	1-808285	4	Pin-Clevis
20	325-17	8	Screw-HH
21	1481	2	Fitting-Grease
22	103-0131	8	Nut-Square
23	3219-3	8	Nut-HH
24	3290-357	4	Nut-HHF
25	3253-7	8	Washer-Lock
26	3256-4	4	Washer-Flat

Ref. No.	Part No.	Qty.	Description
27	3272-10	7	Pin-Cotter
28	1-806800	2	Pin-Cotter
29	322-9	6	Screw-HH
30	103-0384	6	Spacer
31	103-0374	2	Retainer-Band, Brake

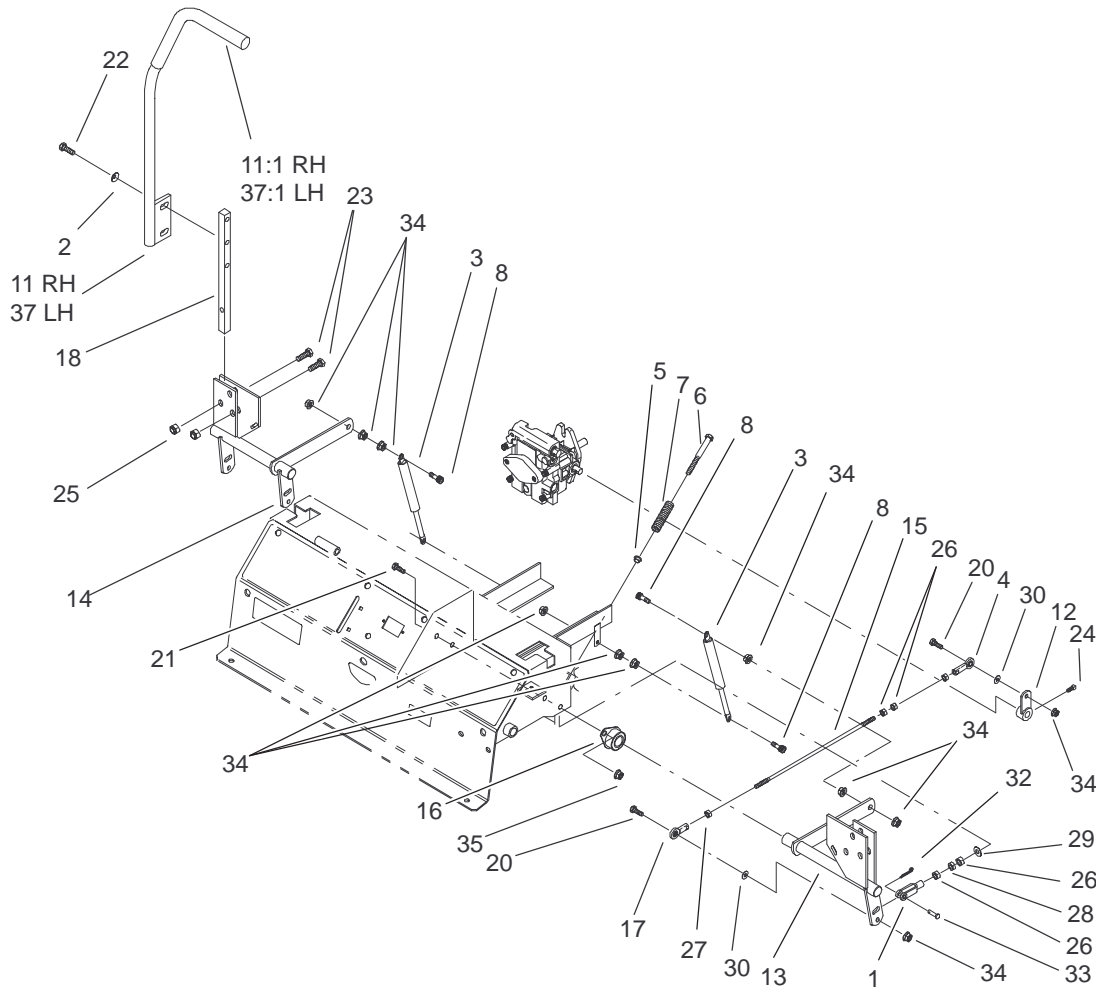

Sheet No.:6

## Steering Control Assembly

Ref. No.	Part No.	Qty.	Description
1	1-303105	2	Yoke-Adjustable
2	98-5975	4	Washer-Belleville
3	1-523027	2	Damper-Control
4	1-543017	2	Balljoint-RH
5	1-603735	2	Bushing-Flanged
6	1-603737	2	Bolt-Return, Neutral
7	1-603807	2	Spring-Return, Neutral
8	1-403180	4	Screw-HH
11	103-0632	1	RH Lever ASM
11:1	1-633257	1	Grip-Control, Motion
12	1-632208	2	Arm-Control, Pump
13	1-642319	1	Control-Motion, LH
14	1-642320	1	Control-Motion, RH
15	1-633153	2	Linkage-Pump/Lever
16	1-633102	4	Bearing-Flange, Side
17	1-633152	2	Balljoint-Thread, LH
18	103-0407	2	Arm-Shaft, Control
20	322-6	4	Screw-HH
21	323-4	8	Screw-HH
22	323-6	4	Screw-HH
23	323-9	6	Screw-HH
24	1-803022	2	Screw
25	3296-39	6	Nut-Lock, NI
26	3219-2	10	Nut-Hex
27	1-804524	2	Nut

Ref. No.	Part No.	Qty.	Description
28	3220-2	2	Nut
29	3256-2	2	Washer-Flat
30	3256-3	4	Washer-Flat
32	3272-5	2	Pin-Cotter
33	1-808280	2	Pin-Clevis
34	32128-20	16	Nut-HF
35	3290-357	8	Nut-HHF
37	103-0631	1	LH Lever ASM
37:1	1-633257	1	Grip-Control, Motion

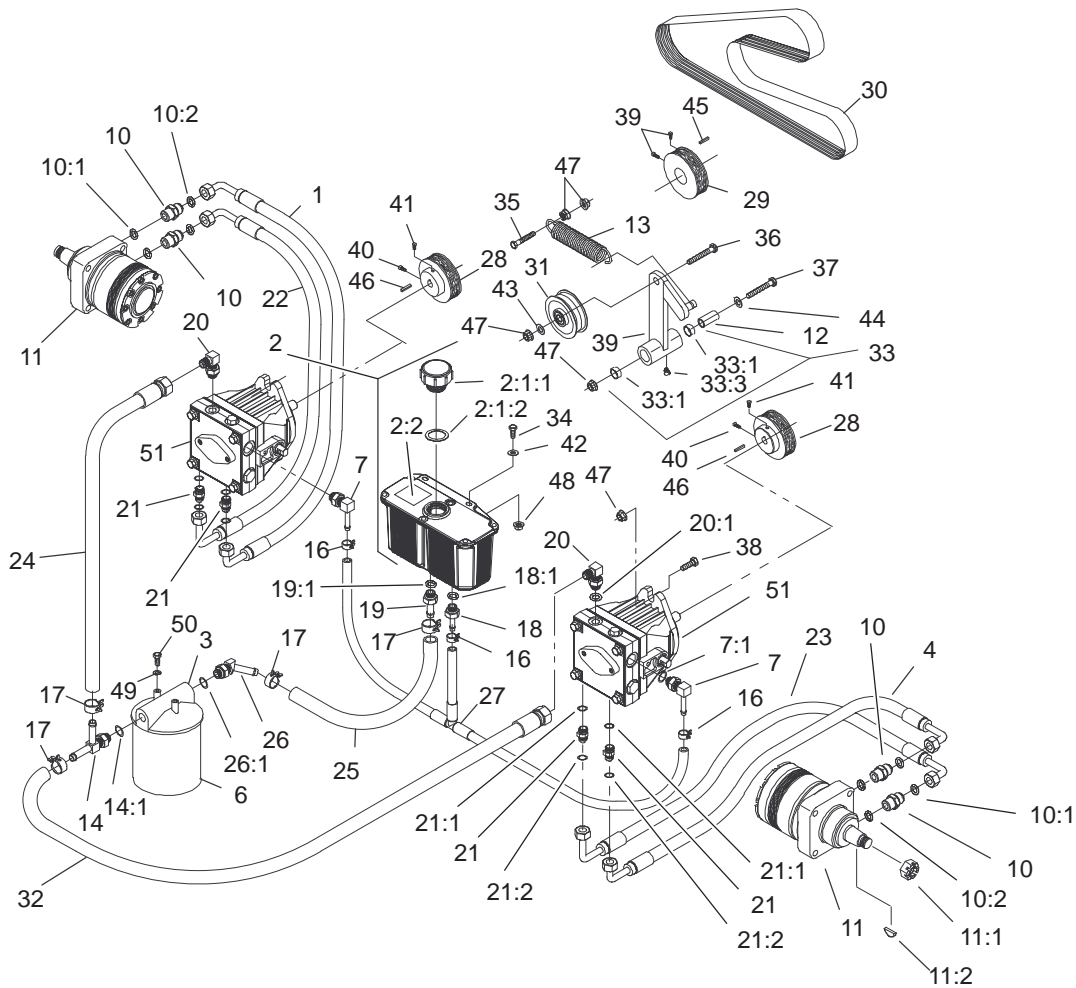

Sheet No.:7

## Hydraulic System Assembly

Ref. No.	Part No.	Qty.	Description
1	103-1764	1	Upper RH Hose ASM
2	103-1947	1	HYD Reservoir ASM
☆2:1		1	Reservoir-HYD
2:1:1	103-1948	1	Cap-HYD Reservoir
2:1:2	103-1949	1	Gasket-Cap
2:2	1-523552	1	Decal-Tank, Hydraulic
3	104-7836	1	Head-Filter
4	103-1682	1	Upper LH Hose ASM
6	1-633752	1	Filter-HYD, Winter
6	1-633750	1	Filter-HYD
7	103-1799	2	Elbow-90°
7:1	237-42	1	O-Ring
10	1-603991	4	Fitting-Straight
10:1	237-80	1	O-Ring
10:2	1-603992	1	O-Ring
11	1-523328	2	Motor-Wheel
11:1	1-809036	1	Nut-HH
11:2	3257-42	1	Key-Woodruff
*11:99	103-2748	1	Kit-Link, Drive
*11:99	1-000139	1	Kit-Bearing
*11:99	1-000099	1	Kit-Seal
12	1-603384	1	Bushing-Pivot, Idler
13	1-633151	1	Spring-Extension
14	103-1828	1	Adapter-Run, Tee
14:1	237-42	1	O-Ring
16	103-1716	3	Clamp-Hose

Ref. No.	Part No.	Qty.	Description
17	103-1988	4	Clamp-Hose
18	103-1801	1	Adapter-Straight
18:1	237-42	1	O-Ring
19	103-1912	1	Adapter-Straight
19:1	237-42	1	O-Ring
20	103-1802	2	Elbow-90°
20:1	237-42	1	O-Ring
21	1-603990	4	Fitting-Straight
21:1	237-79	1	O-Ring
21:2	1-603992	1	O-Ring
22	103-1765	1	Lower RH Hose ASM
23	103-1683	1	Lower LH Hose ASM
24	103-1826	1	HYD Hose ASM
25	103-1808	1	Hose-HYD
26	103-1807	1	Elbow-45°
26:1	237-42	1	O-Ring
27	103-1806	1	HYD Hose ASM
28	1-633568	2	Sheave
29	1-633567	1	Sheave
30	1-633749	1	Belt-Drive, Pump
31	1-633167	1	Sheave-Idler
32	103-1827	1	HYD Hose ASM
33	1-634277	1	Bearing Arm ASM
33:1	1-513034	2	Sleeve-Bearing
33:3	302-40	1	Fitting-Grease
34	321-6	2	Screw-HH

☆ Not serviced separately

\* Not illustrated



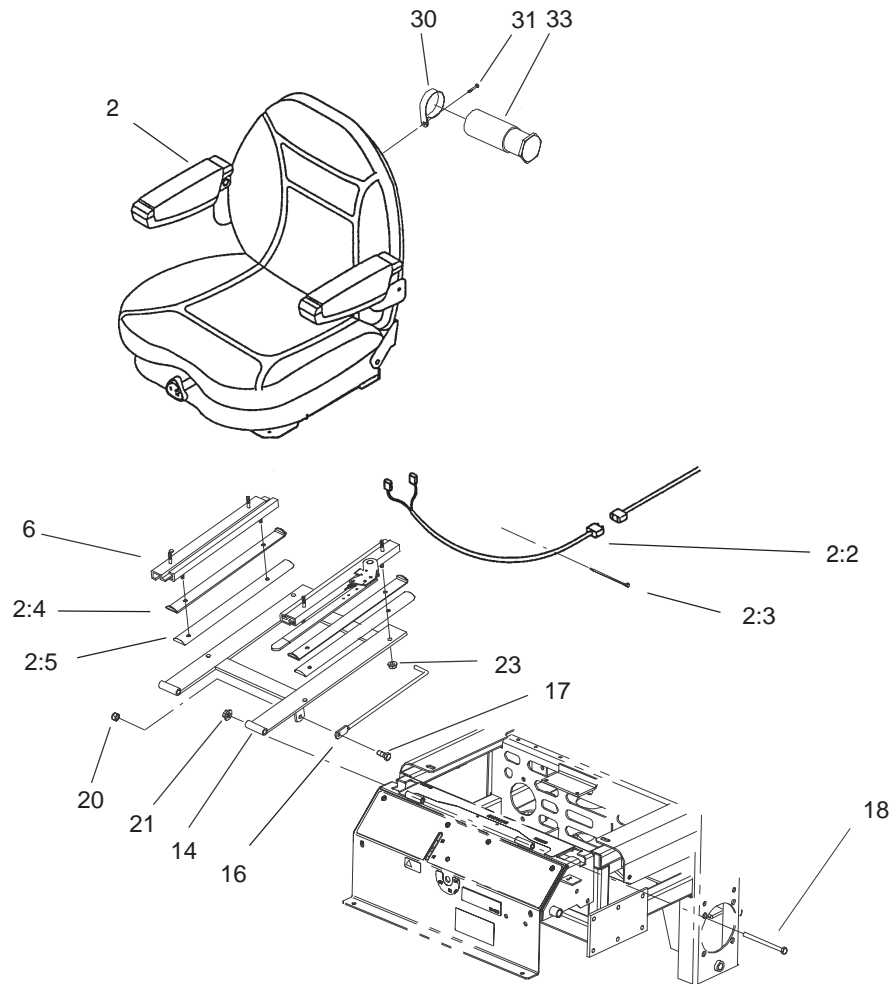

Sheet No.:8

## Seat Assembly

Ref. No.	Part No.	Qty.	Description	Ref. No.	Part No.	Qty.	Description
2	99-8522	1	Kit-Suspension, Seat				
2:2	103-1227	1	Harness, Wiring Seat				
2:3	1-303335	5	Tie-Plastic				
2:4	1-633872-03	2	Stop-Seat				
2:5	1-653282-03	2	Stop/Spacer-Seat				
*2:30	1-643281	1	Switch-Seat				
*2:31	1-631842	1	Kit-Pad, Armrest				
*2:32	1-631843	1	Kit-Boot				
*2:33	1-631844	1	Arm Kit ASM				
*2:34	1-631845	1	Pan ASM				
*2:35	1-631846	1	Kit-Damper				
*2:36	1-631847	1	Kit-Roller				
*2:37	1-631848	1	Kit-Spring & Cable				
*2:38	1-631849	1	Kit-Knob & Shaft				
6	1-643255	1	Track-Seat				
14	1-632187-03	1	Frame-Seat				
16	1-633293	1	Rod-Holdup, Seat				
17	322-5	1	Screw-HH				
18	323-39	2	Screw-HH				
20	3296-29	1	Nut-Lock, NI				
21	3296-39	2	Nut-Lock, NI				
23	32128-20	4	Nut-HF				
30	2412-133	2	R-Clamp				
31	32144-70	2	Screw-HH				
33	74-0720	1	Tube-Manual				

\* Not illustrated







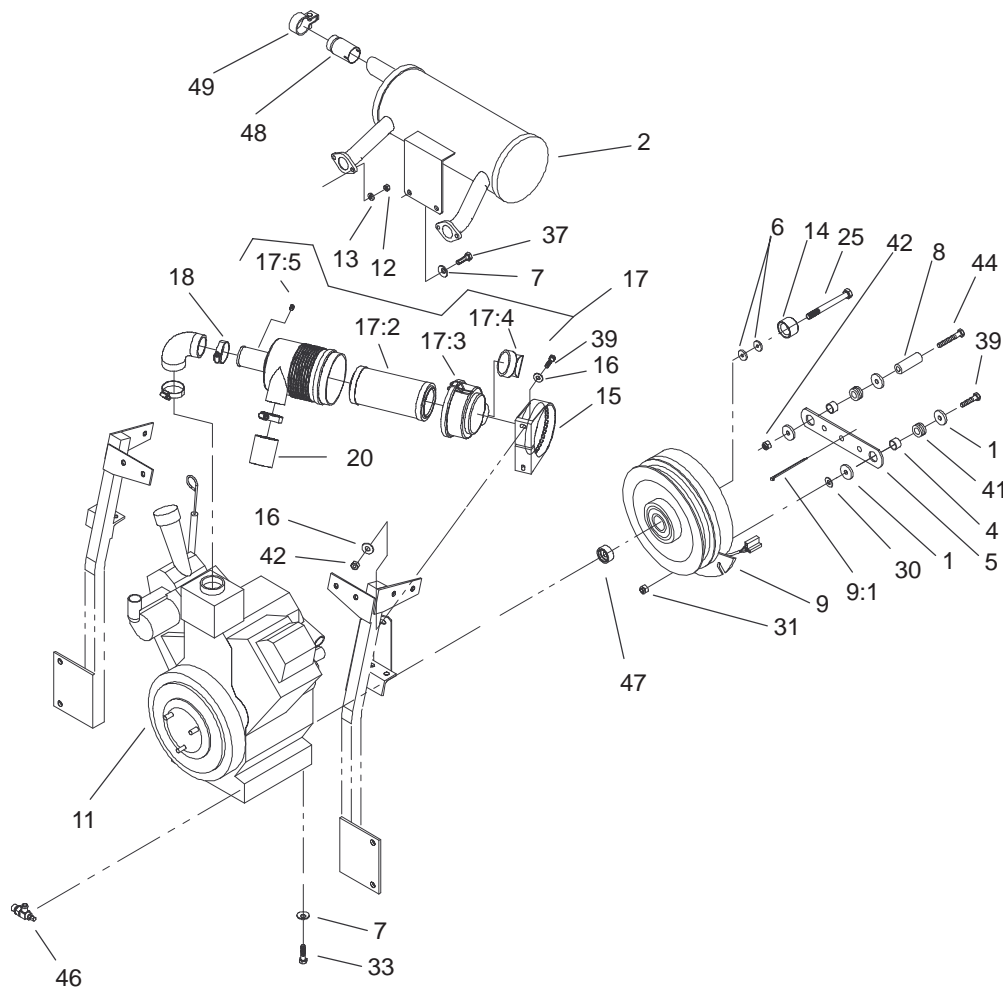

Sheet No.:14

## Engine Assembly

Ref. No.	Part No.	Qty.	Description	Ref. No.	Part No.	Qty.	Description
1	1-613235	4	Washer	31	32128-20	1	Nut-HF
2	103-0059	1	Muffler	33	33115-025	4	Screw-HH
4	1-633545	2	Spacer-Grommet	37	33115-020	2	Screw-HH
5	1-633543-03	1	Strap-Clutch, Brake	39	322-6	3	Screw-HH
6	1-603610	2	Washer-Spring	41	1-633630	2	Grommet-Brake
7	1-303334	6	Washer-Spring	42	3296-29	3	Nut-Lock, NI
8	1-643008	1	Spacer-Anchor, Clutch	44	322-38	1	Screw-HH
9	103-1364	1	Clutch	46	103-0161	1	Valve, Oil Drain
9:1	1-303335	1	Tie-Plastic	47	103-0114	1	Spacer-Clutch
☆11		1	Engine-Kawasaki, Fd750d-As03	48	103-1511	1	Arrestor-Spark
12	33013-00	4	Nut-Hex	49	103-1512	1	Clamp-Muffler
13	1-805004	4	Washer-Lock				
14	103-0152	1	Keeper, Clutch				
15	95-5806	1	Bracket-Mounting				
16	3256-3	4	Washer-Flat				
17	95-5805	1	Air Cleaner ASM				
17:2	93-2195	1	Filter				
17:3	94-3652	1	Cover ASM				
17:4	94-1414	1	Valve-Vacuator				
17:5	285-17	1	Plug-Pipe				
18	1-643009	2	Clamp-Hose				
20	1-643084	1	Hose-Inlet, Air				
25	48-7570	1	Screw - HH				
30	3256-3	1	Washer-Flat				

☆ Not serviced separately

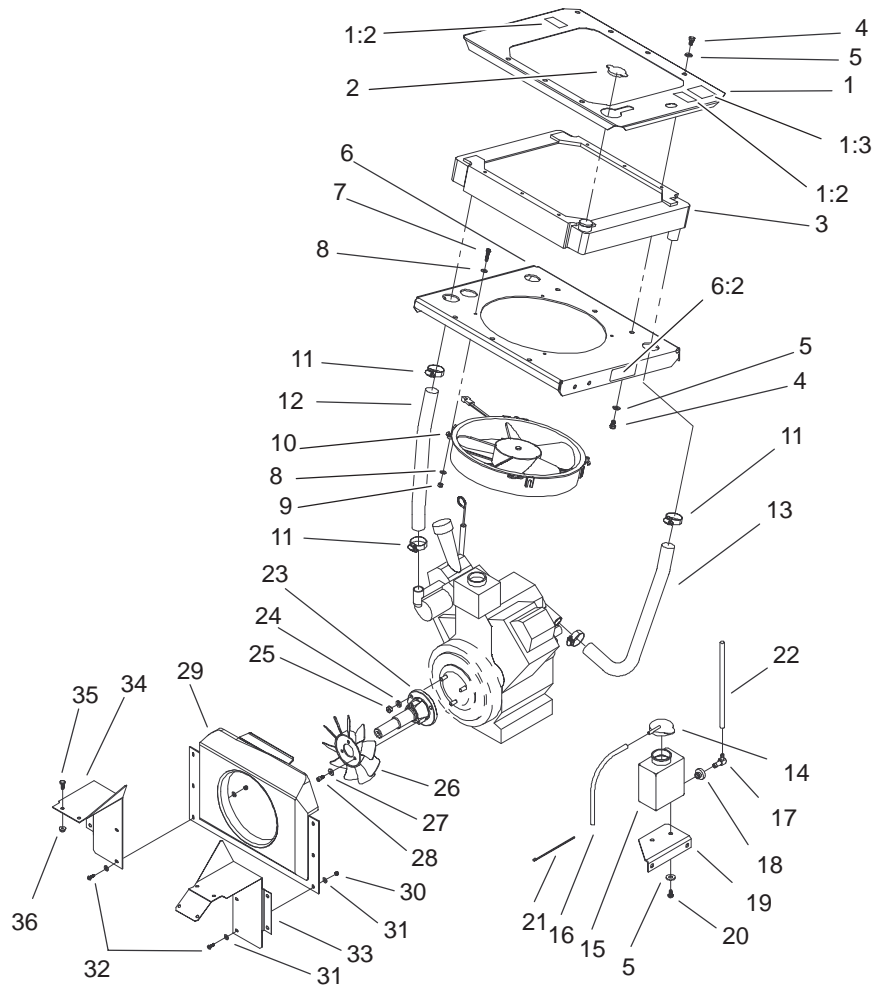

Sheet No.:15

### Engine Assembly (Continued)

Ref. No.	Part No.	Qty.	Description
1	104-7843	1	Radiator Trim Plate ASM
1:2	65-2690	2	Decal-Surface, Hot
1:3	104-2449	1	Decal-Coolant, Havoline
2	1-643161	1	Cap-Radiator
3	103-1046	1	Radiator, Horiz Mount
4	322-1	12	Screw-HH
5	3256-23	14	Washer-Flat
6	100-4301	1	Fan Mounting Plate ASM
6:2	1-643253	2	Decal-Fan, Radiator
7	1-803067	4	Screw
8	3256-16	8	Washer-Flat
9	1-804254	4	Nut
10	1-633831	1	Fan
11	1-633989	4	Clamp-Hose
12	103-0074	1	Hose, Radiator Inlet
13	103-0075	1	Hose, Radiator Outlet
14	1-643164	1	Cap-Tank, Overflow
15	1-643163	1	Tank-Overflow
16	1-643131	1	Hose
17	1-643259	1	Fitting-Elbow
18	1-513645	1	Bushing-Valve, Fuel
19	103-2603-03	1	Bracket-Bottle
20	321-2	2	Screw-HH

Ref. No.	Part No.	Qty.	Description
21	1-303287	3	Tie-Plastic
22	1-643129	1	Hose
23	1-633851	1	Extension-Crankshaft
24	1-805005	3	Washer-Lock
25	33014-00	3	Nut-Hex
26	1-633869	1	Fan-Pump, Cooling
27	3256-22	3	Washer-Flat
28	1-809095	3	Screw-HSH
29	103-0098	1	Shroud, Hydraulic Fan
30	3296-2	6	Nut-Lock
31	3256-14	12	Washer-Flat
32	3290-500	6	Screw-PPH
33	103-0895-03	1	Shield-LH
34	1-633794-03	1	Baffle-Engine Shield, RH
35	321-4	6	Screw-HH
36	32128-33	6	Nut-HF



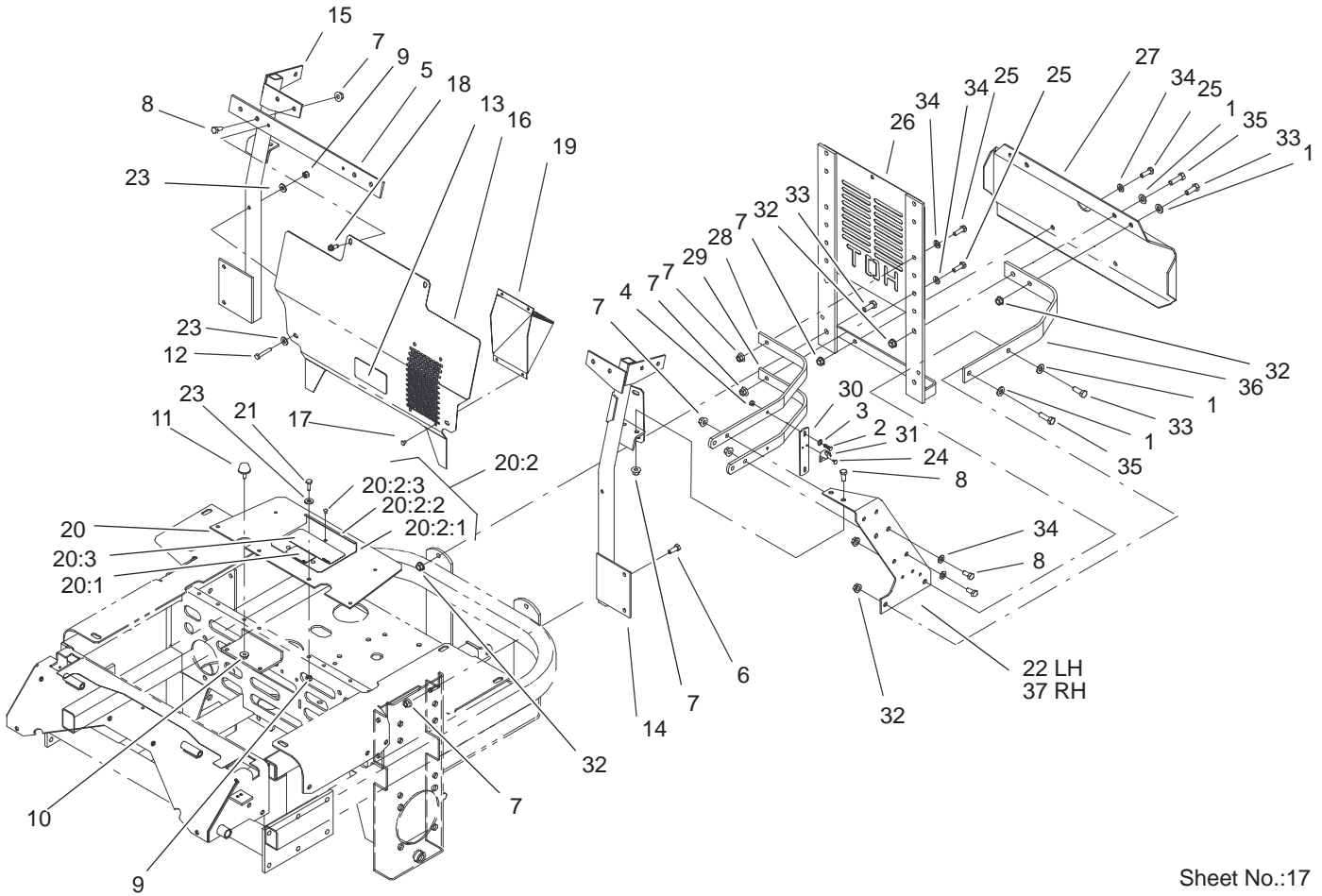

Sheet No.:17

## Cooling Mounting Frame Assembly

Ref. No.	Part No.	Qty.	Description
1	3256-24	6	Washer-Flat
2	1-803069	4	Screw
3	3256-14	4	Washer-Flat
4	3296-2	4	Nut-Lock
5	1-633878-03	1	Crossbar
6	322-4	4	Screw-HH
7	32128-20	12	Nut-HF
8	322-3	8	Screw-HH
9	3296-42	6	Nut-Lock, NI
10	32128-33	2	Nut-HF
11	1-523420	2	Bumper
12	321-9	2	Screw-HH
13	1-643339	1	Decal-Routing, Belt
14	103-0107-03	1	Brace-Radiator, LH
15	1-632985-03	1	Brace-Radiator, RH
16	1-643087-03	1	Deflector-Air
17	3269-3	4	Rivet-Pop
18	49-2040	2	Screw-Tapping
19	103-0110-03	1	Plenum-Intake, Air
20	1-644276	1	Shield ASM
20:1	1-633462	1	Decal-Important
20:2	1-634308	1	Shield/Lift ASM
20:2:1	103-1308	1	Shield-Engine
20:2:2	1-633300-03	1	Lift-Shield
20:2:3	1-803035	3	Rivet-Pop

Ref. No.	Part No.	Qty.	Description
20:3	103-0368	1	Decal-Devices, Rotating
21	321-4	4	Screw-HH
22	103-0896-03	1	Plate-Side, LH
23	3256-2	6	Washer-Flat
24	923786	4	Rivet-Pop
25	322-5	9	Screw-HH
26	1-632873-03	1	Mount-Radiator, Rear
27	1-633886-03	1	Guard-Bumper
28	1-633897-03	2	Rib-Top
29	1-633898-03	2	Rib-Bottom
30	1-633877-03	2	Bar-Latch Hook
31	1-643189	2	Keeper-Rubber Latch
32	3290-357	10	Nut-HHF
33	323-6	6	Screw-HH
34	3256-23	11	Washer-Flat
35	323-7	4	Screw-HH
36	1-633896-03	2	Bar-Radiator Mount Frame
37	103-0897-03	1	Plate-Side, RH

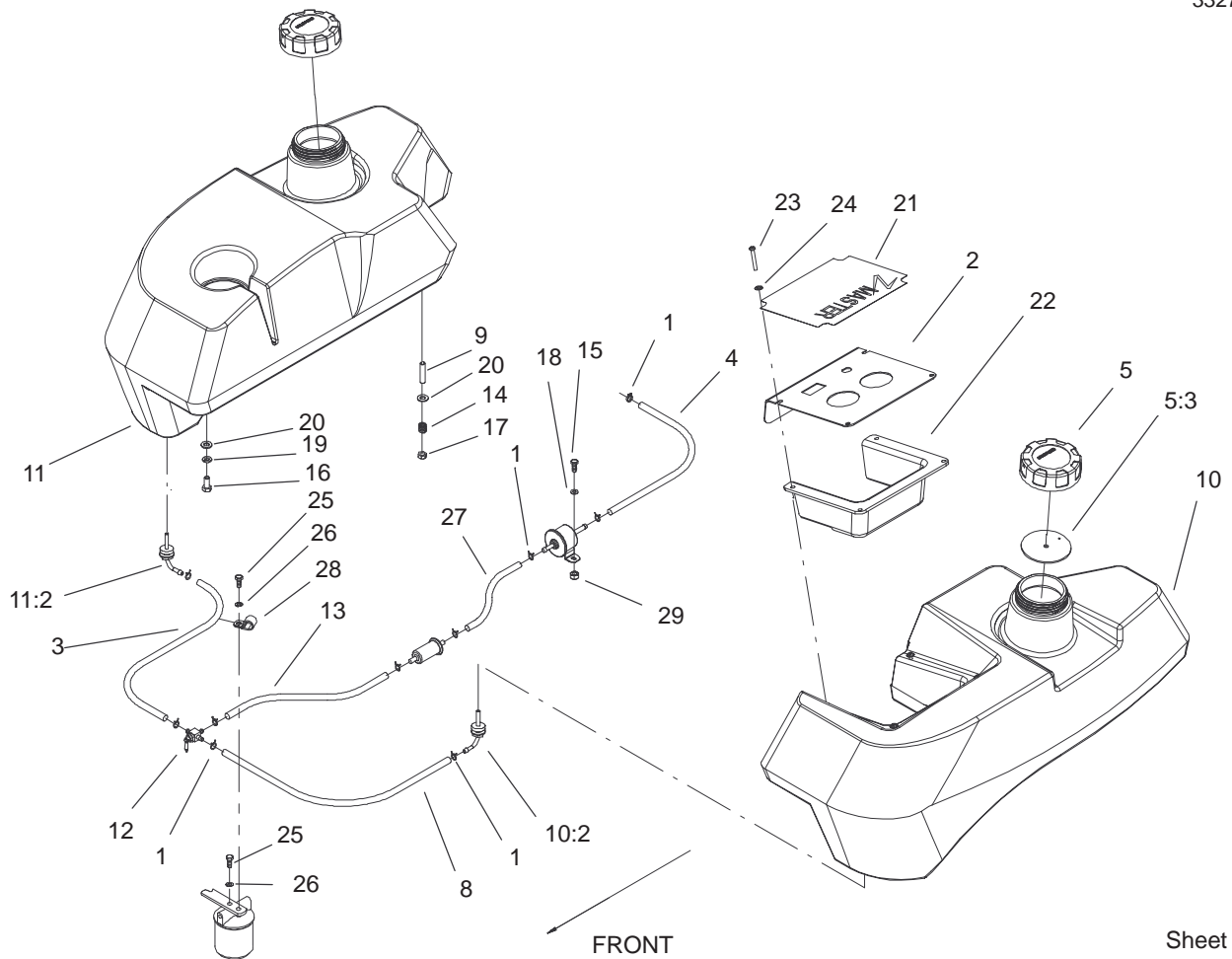

Sheet No.:24

## Tank and Fuel Line Assembly

Ref. No.	Part No.	Qty.	Description
1	1-303077	10	Clamp-Line, Fuel
2	99-4617-03	1	Panel-Control
3	103-2885	1	Hose-Fuel
4	103-1335	1	Hose-Fuel
5	88-3980	2	Gas Cap ASM
5:3	88-4010	1	Gasket-Cap, Gas
8	1-543456	1	Hose-Fuel
9	1-633023	6	Stud
10	105-3629	1	LH Fuel Tank ASM
10:2	103-2605	1	Fitting-Fuel, Bulkhead
11	105-3628	1	RH Fuel Tank ASM
11:2	103-2605	1	Fitting-Fuel, Bulkhead
12	1-633347	1	Valve-Fuel
13	1-303426	1	Hose-Fuel Line
14	1-633349	6	Spring-Tank, Fuel
15	321-4	2	Screw-HH
16	322-3	2	Screw-HH
17	3296-47	6	Nut-Lock, NI
18	3256-2	2	Washer-Flat
19	1-805005	2	Washer-Lock
20	3256-23	8	Washer-Flat
21	99-4612	1	Decal-Control Panel
22	99-4940	1	Shield-Panel, Control
23	1-803071	4	Screw
24	1-303435	4	Washer-Spring
25	321-3	2	Screw-HH

Ref. No.	Part No.	Qty.	Description
26	1-805004	2	Washer-Lock
27	1-643270	1	Hose-Fuel
28	1-513762	1	Clip-Loom
29	32128-33	2	Nut-HF

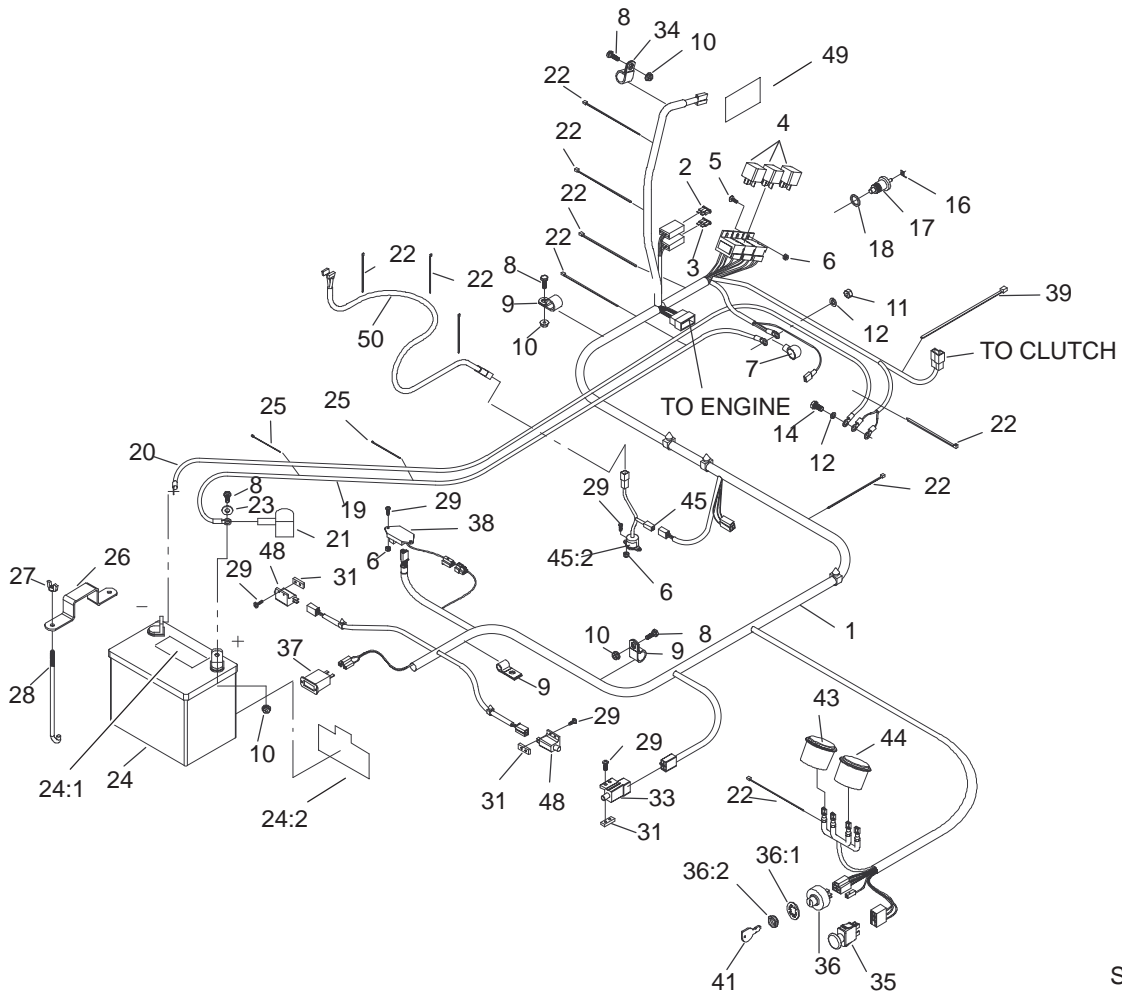

Sheet No.:29

## Electrical System Assembly

Ref. No.	Part No.	Qty.	Description
1	104-7757	1	Harness – Wire
2	1-816001	1	Fuse–Type, Blade
3	1-816003	1	Fuse–Blade Type, 30 Amp
4	1-643275	3	Relay
5	1-803071	2	Screw
6	3296-2	6	Nut–Lock
7	1-543393	1	Insulator–Solenoid
8	321-4	5	Screw–HH
9	1-633396	3	Clip–Loom
10	32128-33	5	Nut–HF
11	33014-00	1	Nut–Hex
12	3256-23	2	Washer–Flat
14	33114-016	1	Screw–HH
16	1-643145	1	Tab
17	103-0283	1	Sender–Temperature
18	1-643153	1	Washer–Aluminum
19	1-523279	1	Wire–Battery, Positive
20	1-633307	1	Wire–Ground
21	1-543391	1	Insulator–Battery
22	1-303335	10	Tie–Plastic
23	3256-2	2	Washer–Flat
24	105-1692	1	Battery
24:1	104-4163	1	Decal–Battery
24:2	104-4164	1	Decal–Battery
25	1-303287	2	Tie–Plastic

Ref. No.	Part No.	Qty.	Description
26	1-633652-03	1	Strap–Holddown, Battery
27	1-543792	2	Wingnut
28	1-633651	2	Bolt–Holddown
29	3290-500	10	Screw–PPH
31	1-633181	3	Plate–Tapped
33	1-633111	1	Switch
34	1-513762	1	Clip–Loom
35	1-633673	1	Switch–Delta
36	88-9830	1	Key Switch ASM
36:1	3254-5	1	Washer–Lock, Internal
36:2	218-461	1	Nut–HH
37	1-513374	1	Meter–Hour
38	100-6186	1	Module–Delay, Seat
39	1-643115	1	Tie–Plastic
41	63-8360	2	Key–Ignition
43	1-643037	1	Gauge–Voltmeter
44	1-643021	1	Gauge–Temperature
45	1-644427	1	Tilt Switch ASM
45:2	1-643401	1	Decal–Switch, Mercury
48	1-513051	2	Switch–Open, Normally
49	103-1027	1	Decal–Relay
50	103-1227	1	Harness, Wiring Seat



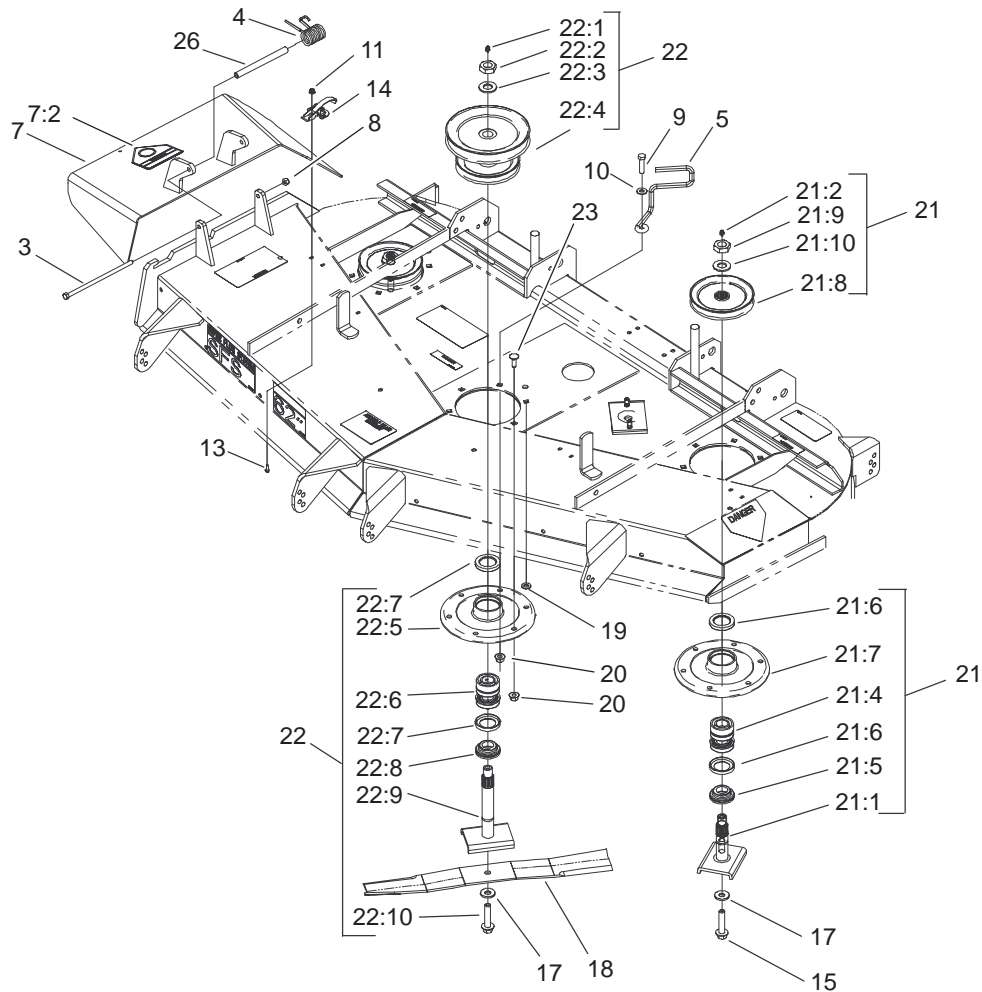

Sheet No.:62

## Spindle and Pulley Assembly

Ref. No.	Part No.	Qty.	Description
3	322-50	1	Screw-Cap
4	104-8554	1	Spring-Torsion
5	99-8933	1	Guide-Belt
7	105-3605	1	Deflector ASM
7:2	54-9220	1	Decal-Danger
8	3296-29	1	Nut-Lock, NI
9	323-8	1	Screw-HH
10	3256-3	1	Washer-Flat
11	32128-17	8	Nut-Lock, Flange
13	3290-321	8	Screw-HWH
14	249-21	4	Clamp-Slotted
15	92-5816	2	Bolt-Blade
17	1-513435	3	Washer-Spring
18	44-6250	3	Blade
19	3256-24	1	Washer-Flat
20	32128-21	18	Nut-HF
21	99-4640	2	Outer Spindle ASM
21:1	27-0920	1	Shaft-Spindle
21:2	302-2	1	Fitting-Grease
21:4	46-8530	1	Bearing ASM
21:5	27-0950	1	Spacer-Bearing, Spindle
21:6	253-139	2	Seal-Oil
21:7	61-4160	1	Housing-Spindle
21:8	99-4614	1	Pulley & Hub
21:9	32146-20	1	Nut-Jam

Ref. No.	Part No.	Qty.	Description
21:10	7-4150	1	Washer-Pinion
22	105-1689	1	Spindle Housing ASM
22:1	302-2	1	Fitting-Grease
22:2	32146-20	1	Nut-Jam
22:3	92-5836	1	Washer-Axle
22:4	100-4307	1	Pulley-Hub ASM
22:5	61-4160	1	Housing-Spindle
22:6	46-8530	1	Bearing ASM
22:7	253-139	2	Seal-Oil
22:8	27-0950	1	Spacer-Bearing, Spindle
22:9	105-1686	1	Spindle Shaft ASM
22:10	92-5816	1	Bolt-Blade
23	3231-22	17	Screw-CARR
26	105-4622	1	Spacer-Mounting, Deflector

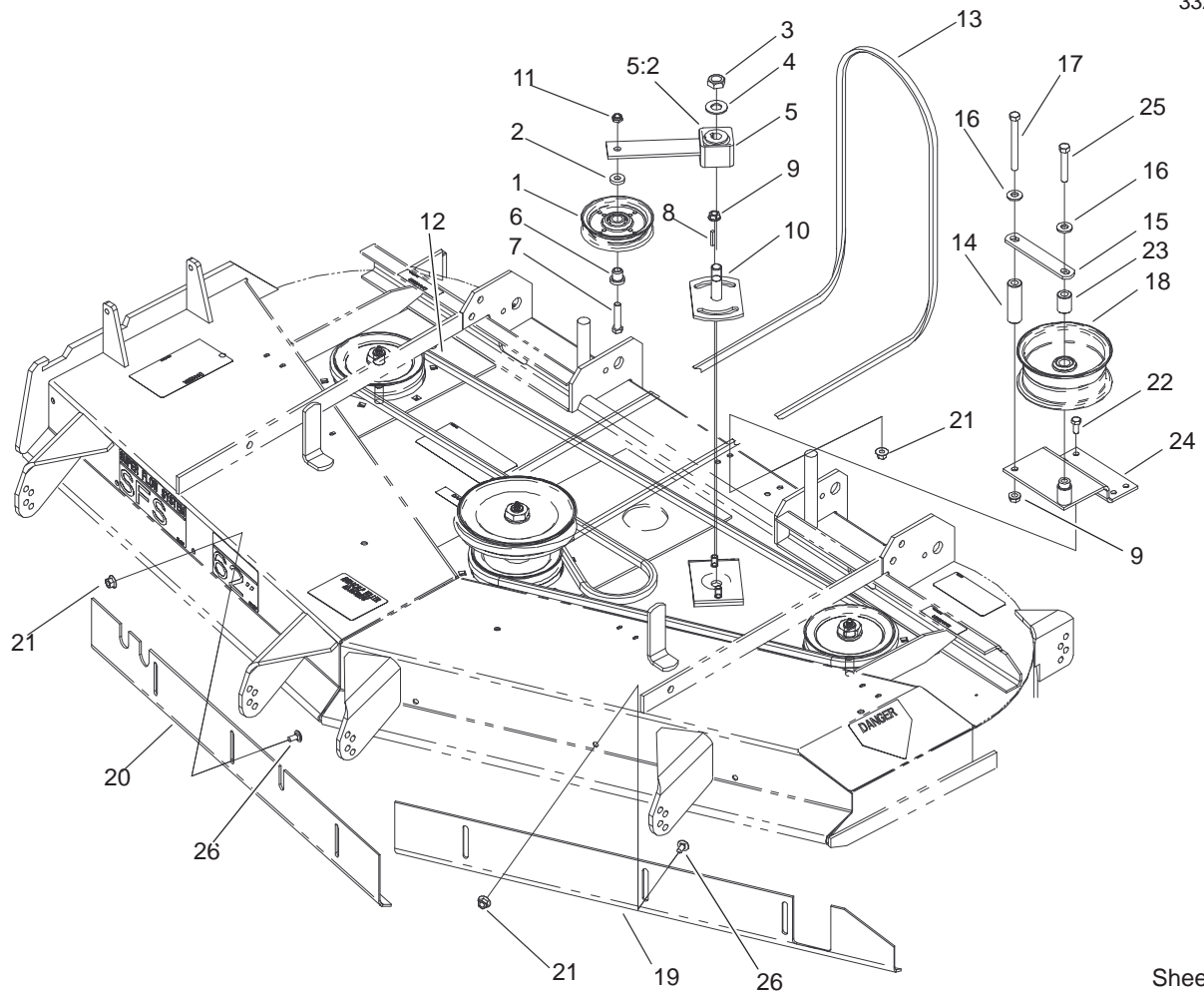

Sheet No.:63

## Belt and Idler Arm Assembly

Ref. No.	Part No.	Qty.	Description
1	65-5940	1	Pulley-Idler
2	7-0081	1	Washer-Flat
3	3296-71	1	Nut-Lock NI
4	3256-27	1	Washer-Flat
5	27-8580	1	Idler Socket & Bushing ASM
5:2	27-8490	1	Bushing-Rubber, Idler
6	65-5950	1	Bushing-Pulley
7	3211-8	1	Screw-HH
8	5-1077	1	Key-Square
9	3290-357	3	Nut-HHF
10	44-6301	1	Plate-Idler, LH
11	3296-5	1	Nut-Lock, NI
12	44-6260	1	V-Belt
13	99-4647	1	V-Belt-Drive, Deck
14	99-4659	1	Spacer-Bracket
15	1-653189	1	Plate-Guide, Belt
16	98-5975	2	Washer-Belleville
17	323-42	1	Screw-HH
18	1-413099	1	Pulley-Idler
19	99-2833-03	1	Baffle-Front, LH
20	99-2834-03	1	Baffle-Front, RH
21	32128-20	10	Nut-HF
22	322-3	4	Screw-HH
23	1-653190	1	Spacer
24	99-4684-01	1	Bracket-Pulley

Ref. No.	Part No.	Qty.	Description
25	323-11	1	Screw-HH
26	3230-18	6	Screw-CARR

# Electrical Schematic

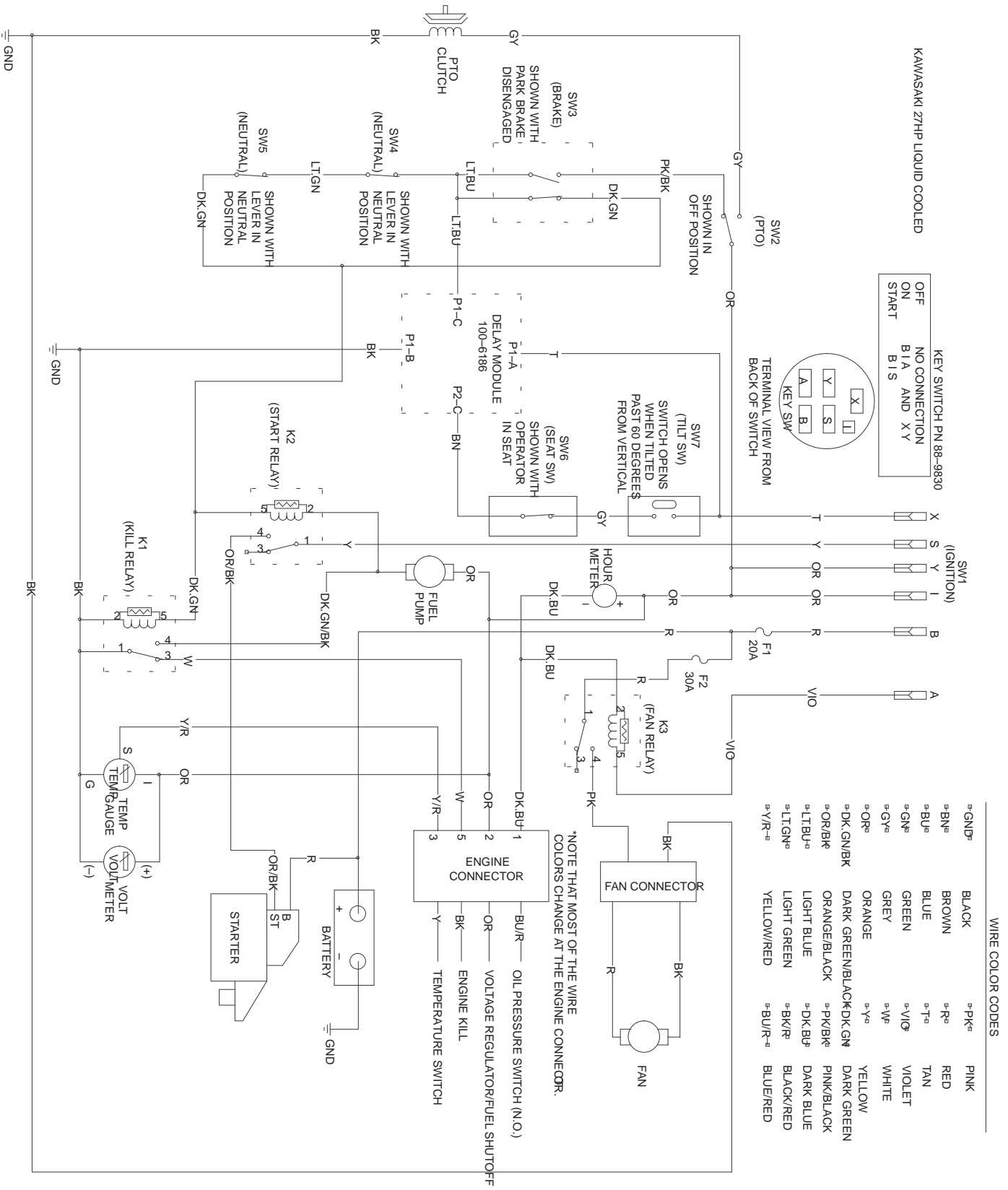

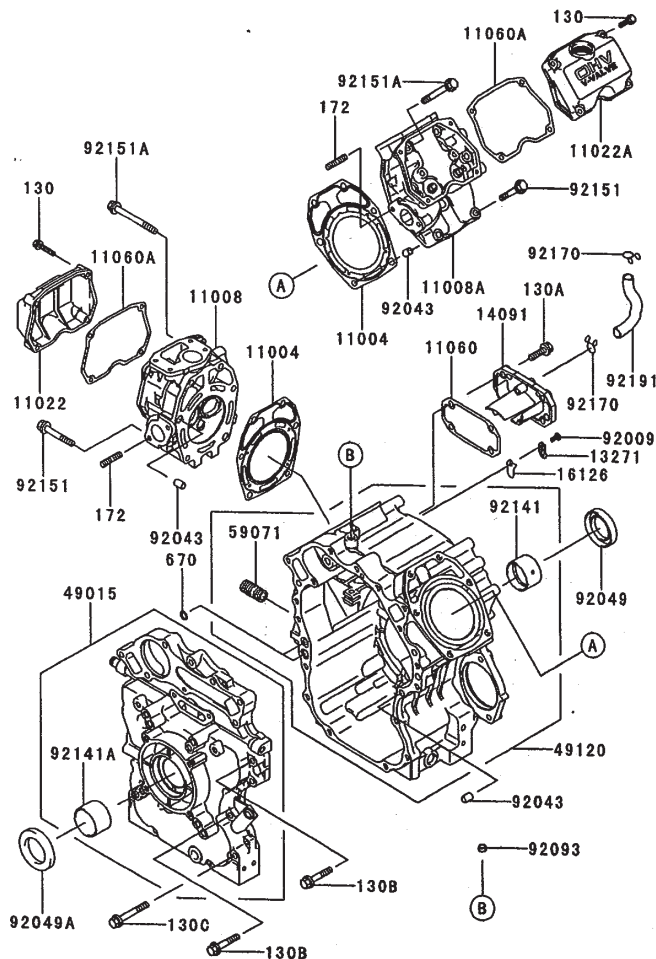

### Cylinder/Crankcase (Kawasaki FD750D-AS03)

Ref. No.	Part No.	Qty.	Description
	11004	2	Gasket-Head
	11008	1	Head-Comp-Cylinder
	11008A	1	Head-Comp-Cylinder
	11022	1	Case-Rocker
	11022A	1	Case-Rocker
	11060	1	Gasket, Breath
	11060A	2	Gasket, Rocker, Case
	13271	2	Plate
	14091	1	Cover, Breath
	16126	2	Valve, Breath
	49015	1	Cover-Crankcase
	49120	1	Crankcase-Comp
	59071	1	Joint
	92009	2	Screw
	92043	6	Pin
	92049	1	Seal-Oil
	92049A	1	Seal-Oil
	92093	1	Seal
	92141	1	Bearing-Plane
	92141A	1	Bearing-Plane
	92151	4	Bolt
	92151A	8	Bolt
	92170	2	Clamp
	92191	1	Tube
	130	8	Bolt-Flanged
	130A	4	Bolt-Flanged

Ref. No.	Part No.	Qty.	Description
	130B	4	Bolt-Flanged
	130C	4	Bolt-Flanged
	172	4	Bolt-Stud
	670	2	O-Ring

Obtain Parts From Kawasaki

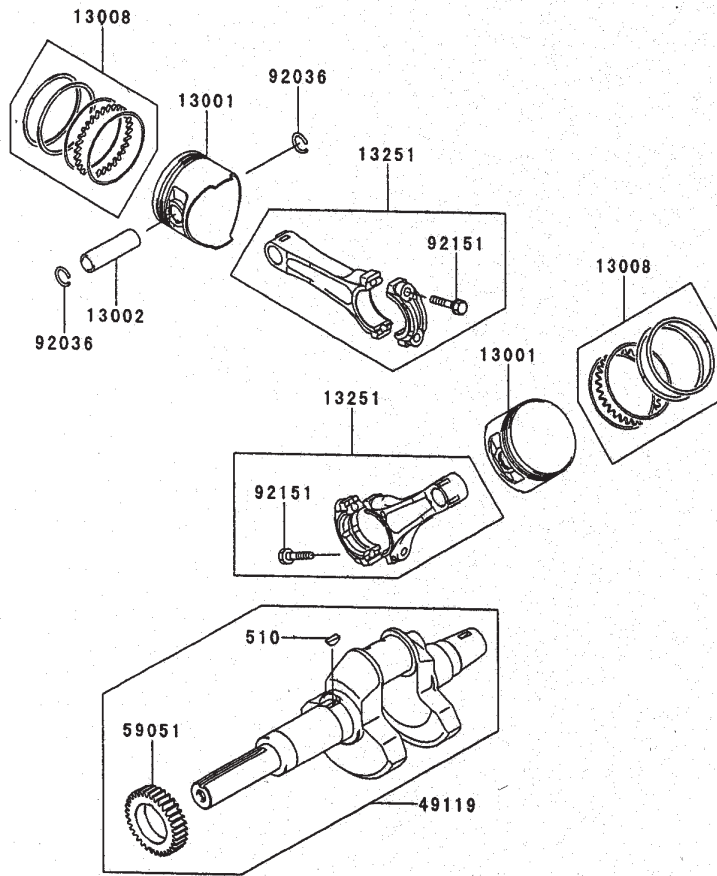

### Piston/Crankshaft (Kawasaki FD750D-AS03)

Ref. No.	Part No.	Qty.	Description
13001	13001-2125	2	Piston-Engine
13002	13002-2069	2	Pin-Piston
13008	13008-6007	2	Ring-Set-Piston
13251	13251-2058	2	Rod ASM-Connecting
49119	49119-2198	1	Crankshaft ASM
59051	59051-2358	1	Gear-Spur, 33T
92036	92036-008	4	Ring-Snap
92151	92151-2150	4	Bolt
510	510A5100	1	Key-Woodruff

Ref. No.	Part No.	Qty.	Description

Obtain Parts From Kawasaki





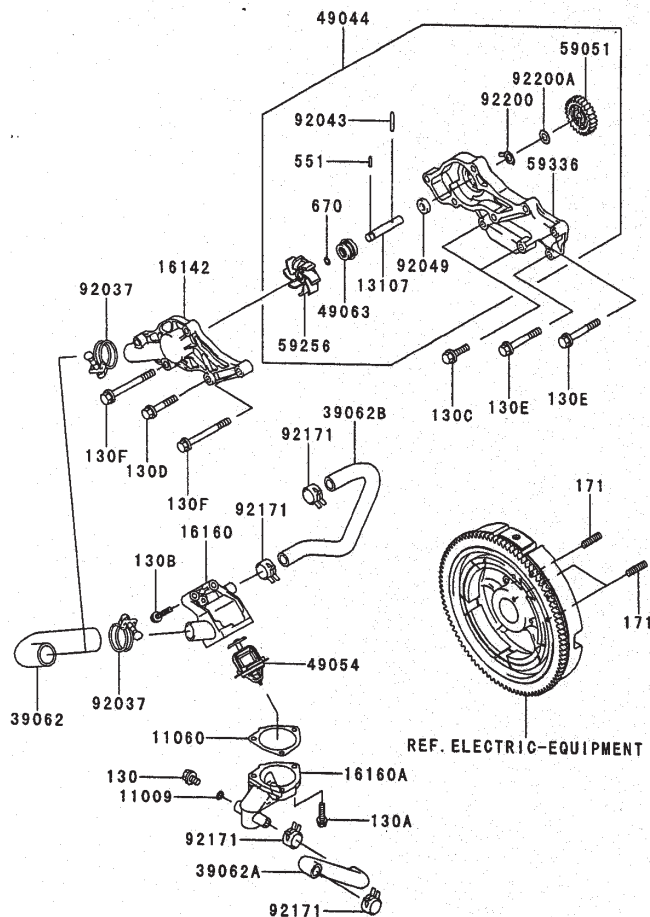

## Cooling Equipment (Kawasaki FD750D-AS03)

Ref. No.	Part No.	Qty.	Description
11009	11009-3028	1	Gasket
11060	11060-2475	1	Gasket-Thermostat
13107	13107-2097	1	Shaft-Impeller
16142	16142-2077	1	Cover-Pump
16160	16160-2127	1	Body-Upper
16160A	16160-6002	1	Body-Valve
39062	39062-2080	1	Hose-Cooling
39062A	39062-2083	1	Hose-Cooling
39062B	39062-2084	1	Hose-Cooling
49044	49044-2063	1	Pump-Water
49054	49054-2058	1	Thermostat
49063	49063-1054	1	Seal-Mechanical
59051	59051-2355	1	Gear-Spur, 25T
59256	59256-2069	1	Impeller
59336	59336-2078	1	Case-Pump
92037	92170-1284	2	Clamp
92043	92043-2237	1	Pin
92049	92049-2111	1	Seal-Oil
92171	92171-2056	4	Clamp
92200	92200-2134	1	Washer
92200A	92200-2135	1	Washer
130	130C0812	1	Bolt-Flanged
130A	130G0625	3	Bolt-Flanged
130B	130G0635	2	Bolt-Flanged
130C	130G0830	2	Bolt-Flanged
130D	130G0845	1	Bolt-Flanged

Ref. No.	Part No.	Qty.	Description
130E	130G0860	2	Bolt-Flanged
130F	130G0880	4	Bolt-Flanged
171	171G0818	3	Bolt-Stud
551	551A0314	1	Pin-Dowel
670	670B1507	1	O-Ring

Obtain Parts From Kawasaki



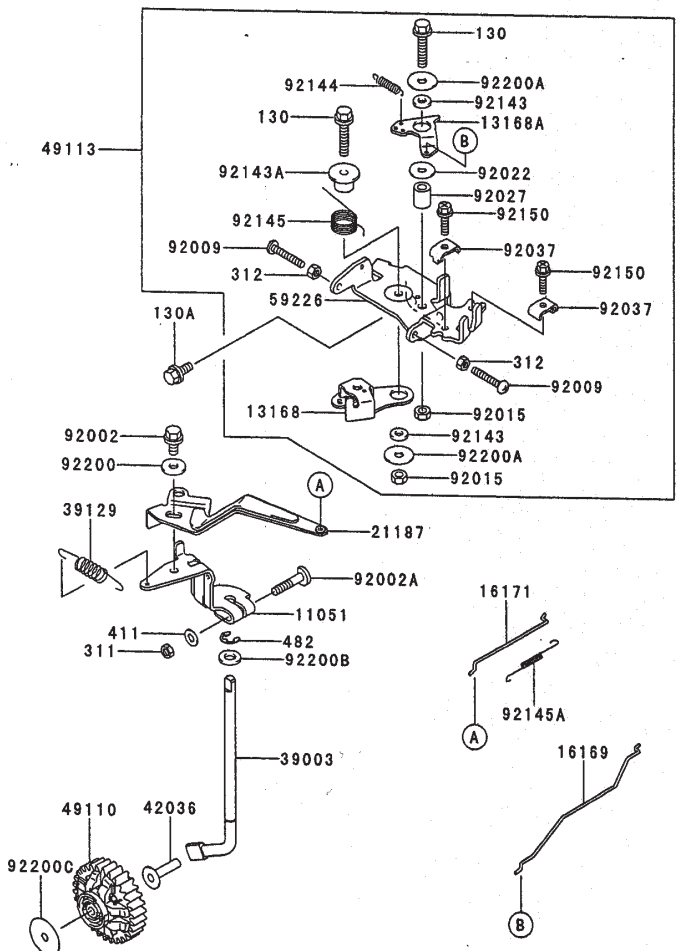

### Control Equipment (Kawasaki FD750D-AS03)

Ref. No.	Part No.	Qty.	Description
	11051	1	Bracket
	13168	1	Lever-Throttle
	13168A	1	Lever-Choke
	16169	1	Link-Choke
	16171	1	Link
	21187	1	Arm ASM
	39003	1	Arm-Pivot
	39129	1	Spring-Governor
	42036	1	Sleeve
	49110	1	Governor ASM
	49113	1	Panel-Comp-Control
	59226	1	Panel-Control
	92002	1	Bolt
	92002A	1	Bolt
	92009	2	Screw
	92015	2	Nut
	92022	1	Washer
	92027	1	Collar
	92037	2	Clamp
	92143	2	Collar
	92143A	1	Collar
	92144	1	Spring
	92145	1	Spring
	92145A	1	Spring
	92150	2	Bolt
	92200	1	Washer

Ref. No.	Part No.	Qty.	Description
	92200A	2	Washer
	92200B	1	Washer
	92200C	1	Washer
	130	2	Bolt-Flanged
	130A	2	Bolt-Flanged
	311	2	Nut-Hex
	312	2	Nut-Hex
	411	1	Washer
	482	1	Circlip-Type E

Obtain Parts From Kawasaki

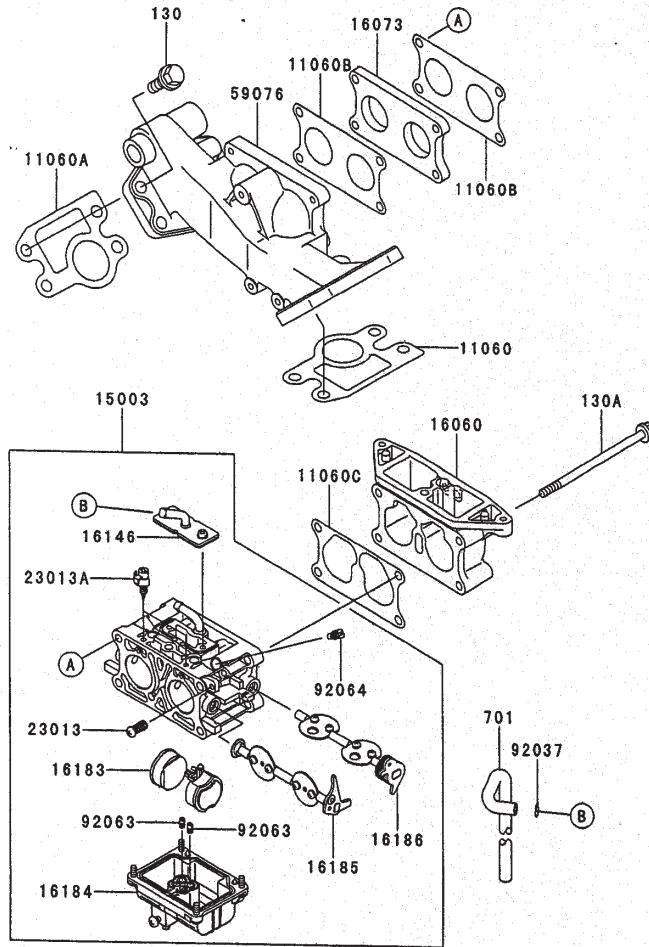

## Carburetor (Kawasaki FD750D-AS03)

Ref. No.	Part No.	Qty.	Description	Ref. No.	Part No.	Qty.	Description
	11060	1	Gasket-Intake				
	11060A	1	Gasket-Intake				
	11060B	2	Gasket-Intake Pipe				
	11060C	1	Gasket-Carburetor				
	15003	1	Carburetor ASM				
	16060	1	Pipe-Intake				
	16073	1	Insulator				
	16146	1	Cover ASM				
	16183	1	Float ASM				
	16184	1	Float Chamber ASM				
	16185	1	Throttle Valve ASM				
	16186	1	Choke Valve ASM				
	23013	1	Screw ASM				
	23013A	1	Screw ASM				
	59076	1	Manifold-Intake				
	92037	1	Clamp				
	92063	2	Jet-Main				
	92064	2	Jet-Pilot				
	130	8	Bolt-Flanged				
	130A	4	Bolt-Flanged				
	701	1	Tube-PVC				

Obtain Parts From Kawasaki





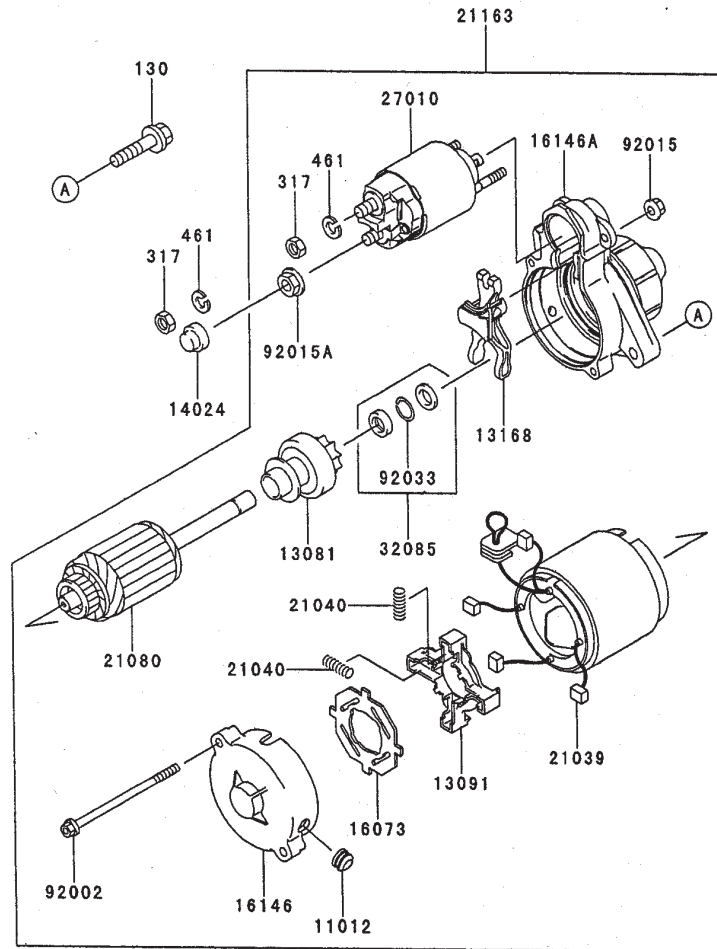

### Starter (Kawasaki FD750D-AS03)

Ref. No.	Part No.	Qty.	Description	Ref. No.	Part No.	Qty.	Description
11012	11012-2226	1	Cap				
13081	13081-2108	1	Clutch ASM				
13091	13091-2068	1	Holder-Brush				
13168	13168-2131	1	Lever-Shift				
14024	14024-2205	1	Cover				
16073	16073-2098	1	Insulator				
16146	16146-2187	1	Cover ASM				
16146A	16146-2225	1	Cover ASM				
21039	21039-2059	4	Brush				
21040	21040-2052	4	Spring-Brush				
21080	21080-2054	1	Armature				
21163	21163-2120	1	Starter-Electric				
27010	27010-2122	1	Switch				
32085	32085-2097	1	Stopper				
92002	92002-2277	2	Bolt				
92015	92015-2146	2	Nut				
92015A	92015-2147	1	Nut				
92033	92033-2081	1	Ring-Snap				
130	130G0835	2	Bolt-Flanged				
317	317B0800	2	Nut-Hex				
461	461F0800	2	Washer-Spring				

Obtain Parts From Kawasaki

