



Z255

Z Master[®] with 62in SFS Side Discharge Mower

Model No. 74234—22000001 and Up

Parts Catalog

Ordering Replacement Parts

To order replacement parts, please supply: the part number, the quantity, and the description of each part desired.

Understanding Reference Numbers

Each identified part in an illustration has a reference number. The reference number for a part also appears in the parts list, along with other information about the part.

This catalog uses two special reference number formats, one to indicate parts in a service assembly and another to indicate the quantity of a given part in an illustration.

Service Assembly Reference Numbers

Parts in service assemblies have reference numbers in the form **a:b**. The **a** represents the reference number of the entire service assembly and the **b** represents a sequential number unique to each part within the service assembly.

For example, a wheel assembly might be identified by reference number **6**, the tire by **6:1**, the valve by **6:2**, and the wheel by **6:3**. When you order the assembly identified by reference number **6**, you receive all parts identified by reference numbers **6:1**, **6:2**, and **6:3**. However, you may also order any part individually.

Reference numbers of this type appear in illustrations and in part lists.

Reference Numbers Indicating Quantity

In an illustration, if a reference number indicates more than one part, the reference number has the form **nX y**. The **n** represents the quantity of the part, the **X** is the multiplication symbol, and the **y** represents the reference number.

For example, in an illustration, the reference number **2X 37** means that two of the parts identified by reference number **37** are indicated.

Contents

Description	Page	Description	Page
Front Frame Assembly	4	Valve/Camshaft Assembly	
Caster and Wheel Assembly	5	Kawasaki FH721D-AS05	25
Main Frame Assembly	6	Lubrication Equipment Assembly	
Brake and Wheel Hub Assembly	7	Kawasaki FH721D-AS05	26
Steering Control Assembly	8	Cooling Equipment Assembly	
Hydraulic System Assembly	9	Kawasaki FH721D-AS05	27
Seat Assembly	11	Electric Equipment Assembly	
Deck Connection Assembly	12	Kawasaki FH721D-AS05	28
Drive Idler Assembly	13	Control Equipment Assembly	
Z-Stand Assembly	14	Kawasaki FH721D-AS05	29
Engine and Clutch Assembly	15	Carburetor Assembly	
Guard Assembly	16	Kawasaki FH721D-AS05	30
Fuel System Assembly	17	Air Filter/Muffler Assembly	
Electrical System Assembly	18	Kawasaki FH721D-AS05	31
Deck, Deflector and Roller Assembly	19	Fuel Tank/Fuel Valve Assembly	
Spindle and Pulley Assembly	20	Kawasaki FH721D-AS05	32
Belt and Idler Arm Assembly	21	Starter Assembly	
Electrical Schematic	22	Kawasaki FH721D-AS05	33
Cylinder/Crankcase Assembly		P.T.O. Equipment Assembly	
Kawasaki FH721D-AS05	23	Kawasaki FH721D-AS05	34
Piston/Crankshaft Assembly		Label Assembly	
Kawasaki FH721D-AS05	24	Kawasaki FH721D-AS05	35

Accessories

Description	Model / Part No.	Description	Model / Part No.
Suspension Seat Kit	99-8522	Striping Kit	30163
Hitch Kit	99-8925	Z-Recycler Kit	100-9678
Atomic Blade Assembly	104-1304		

Part Description Abbreviations

Part descriptions in this catalog may include the following abbreviations.

Abbreviation	Meaning	Abbreviation	Meaning
AR	as required	HYD	hydraulic
ASM	assembly	INC	incorporated
CARR	carriage	LH	left hand
DEG	degrees	NI	nylon insert
FH	flat head	PPH	Phillips pan head
GA	gauge	PTH	Phillips truss head
HF	hex flange	PTO	power take off
HH	hex head	RH	right hand
HHF	hex head flange	SFH	slotted fillister head
HLH	hex lag head	SHH	slotted hex head
HJ	hex jam	SQH	square head
HOC	height-of-cut	SHWH	slotted hex washer head
HS	hex socket	SPH	slotted pan head
HSBH	hex socket button head	SRH	slotted round head
HSFH	hex socket flat head	STD	standard
HSH	hex socket head	TAP	self tapping
HWH	hex washer head	TTH	Torx truss head
HWHTF	hex washer head thread forming	WH	wing head

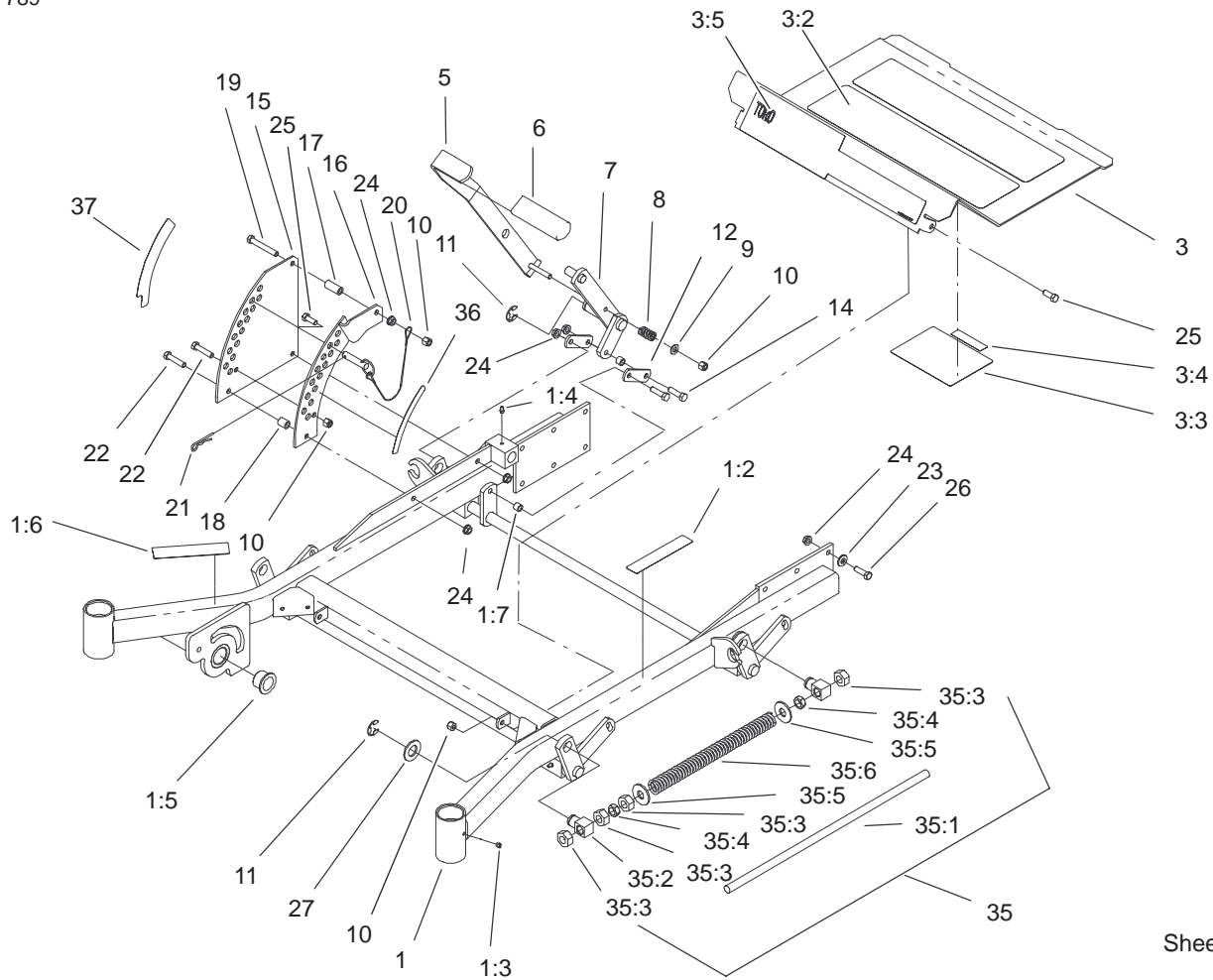

Sheet No.: 2

Front Frame Assembly

Ref. No.	Part No.	Qty.	Description
1	104-5132	1	Frame ASM
1:2	1-633818	1	Decal-Warning
1:3	1-811010	2	Plug
1:4	302-19	5	Fitting-Grease
1:5	94-1291	2	Bushing-Special
1:6	104-7759	1	Decal-Warning
1:7	103-1918	1	Bushing
3	100-6509	1	Floorpan ASM
3:2	1-633553	3	Pad-Antiskid
3:3	1-633766	1	Decal-Check
3:4	98-5954	1	Decal-Missing, Cover
3:5	1-633737	1	Decal-Z-Master
5	103-2083-03	1	Lever-Lift
6	1-633295	1	Grip-Lever, Lift
7	103-2064-03	1	Arm-Lift, Deck
8	1-633325	1	Spring-Compression
9	3256-24	1	Washer-Flat
10	3296-39	5	Nut-Lock, NI
11	32151-103	5	Ring-Snap
12	1-633068	2	Arm-Lift, Deck
14	323-29	2	Screw-HH
15	1-633889-01	1	Plate-Lift, Deck
16	1-632899-01	1	Plate-Lift, Deck
17	1-633082	1	Bushing-Lever, Lift
18	1-633080	1	Bushing-Lever, Lift
19	323-13	1	Screw-HH

Ref. No.	Part No.	Qty.	Description
20	1-633097	1	Pin-Hitch W/Lanyard
21	1-806005	1	Pin-Hair
22	323-9	2	Screw-HH
23	98-5975	12	Washer-Belleville
24	3290-357	17	Nut-HHF
25	323-6	3	Screw-HH
26	323-7	12	Screw-HH
27	3256-29	4	Washer-Flat
☆35		2	Front Frame Spring ASM
35:1	1-633096	1	Rod-Lift, Deck
35:2	1-633441	2	Swivel-Deck Mount, Rear
35:3	3217-11	4	Nut-Hex
35:4	3218-6	2	Nut-Jam
35:5	3256-7	2	Washer-Flat
35:6	1-633064	1	Spring-Support, Deck
36	1-633706	1	Decal-Height, Deck
37	1-633345	1	Decal-Height, Deck

☆ Not serviced separately

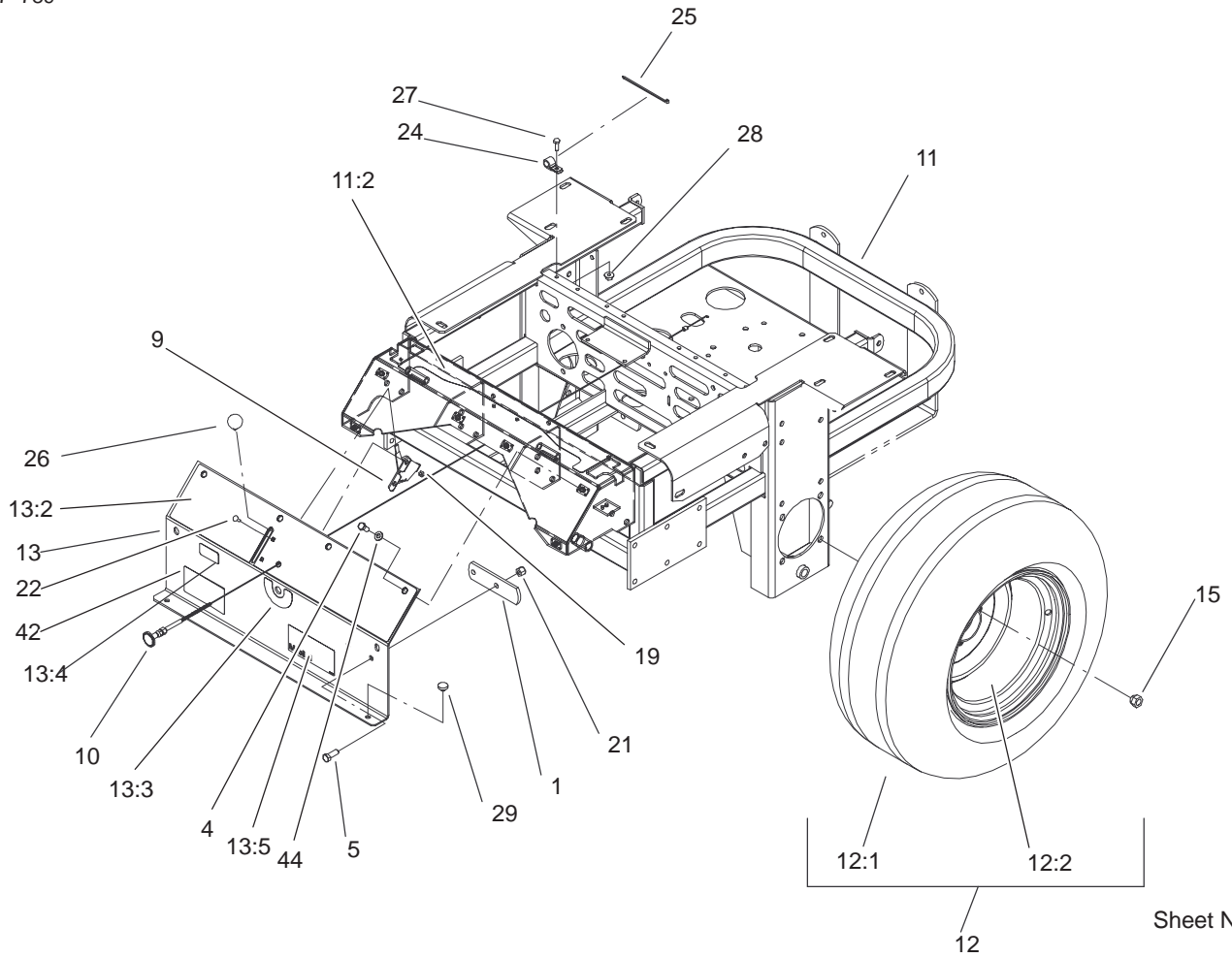

Sheet No.: 4

Main Frame Assembly

Ref. No.	Part No.	Qty.	Description
1	1-633964-03	1	Stop-Brake, Park
4	322-3	6	Screw-HH
5	323-6	2	Screw-HH
9	1-633696	1	Cable-Throttle
10	1-603336	1	Control-Choke
11	105-6120	1	Rear Frame ASM
11:2	103-2433	1	Decal, Top Console
12	1-633970	2	Wheel & Tire ASM
12:1	1-633993	1	Tire
12:2	1-633992	1	Wheel
13	99-4623	1	Console ASM
13:2	100-4311	1	Decal-Panel, Control
13:3	103-0262	1	Decal-Valve, Fuel
13:4	98-4387	1	Decal-Protection, Ear
13:5	104-8172	1	Decal-Mobil 1
15	242-50	8	Nut-Lug
19	3296-2	2	Nut-Lock
21	3296-39	2	Nut-Lock, NI
22	1-807513	2	Bolt-CARR
24	1-513762	1	Clip-Loom
25	1-303335	1	Tie-Plastic
26	1-513592	1	Knob-Ball
27	321-4	1	Screw-HH
28	32128-33	1	Nut-HF
29	1-513658	2	Bumper-Catcher, Grass

Ref. No.	Part No.	Qty.	Description
42	1-633736	1	Decal-Toro, Z255
44	3256-23	6	Washer-Flat

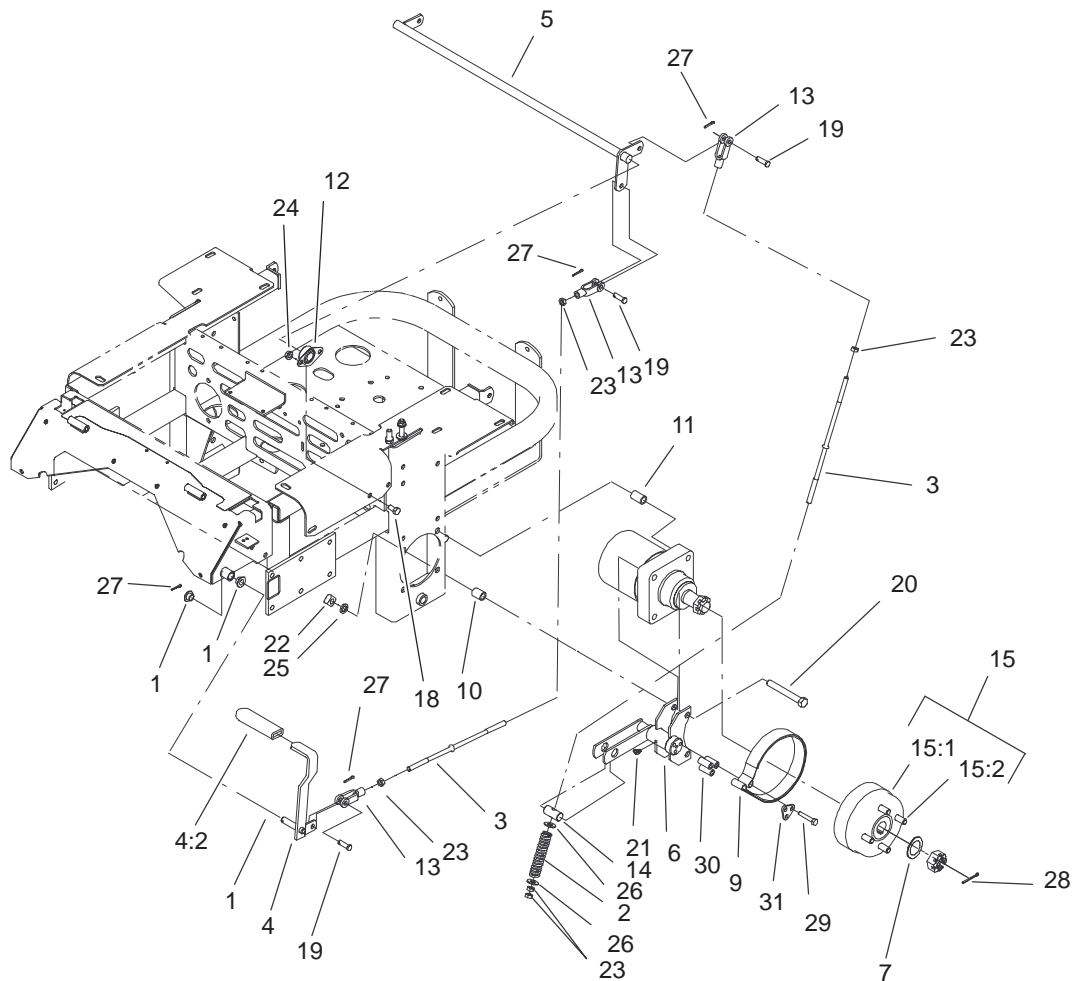

Sheet No.: 5

Brake and Wheel Hub Assembly

Ref. No.	Part No.	Qty.	Description
1	1-513140	2	Bearing-Control
2	1-633454	2	Spring-Brake
3	1-633477	3	Rod-Brake
4	1-634500	1	Brake Lever ASM
4:2	1-633268	1	Grip-Lever, Brake
5	1-632217-03	1	Shaft-Brake
6	103-0352-03	2	Bracket-Brake
7	1-523157	2	Washer-Spacer
9	103-0355	2	Band-Brake
10	1-633380	4	Spacer-Wheel, Short
11	1-633382	4	Spacer-Wheel, Long
12	1-633102	2	Bearing-Flange, Side
13	1-633131	4	Yoke-Linkage, Brake
14	1-633144	2	Pin-Trunion
15	103-0590	2	Hub-Wheel
15:1	103-0589	1	Hub-Wheel
15:2	1-633926	4	Stud-Wheel
18	323-4	4	Screw-HH
19	1-808285	4	Pin-Clevis
20	325-17	8	Screw-HH
21	1481	2	Fitting-Grease
22	103-0131	8	Nut-Square
23	3219-3	8	Nut-HH
24	3290-357	4	Nut-HHF
25	3253-7	8	Washer-Lock
26	3256-4	4	Washer-Flat

Ref. No.	Part No.	Qty.	Description
27	3272-10	7	Pin-Cotter
28	1-806800	2	Pin-Cotter
29	322-9	6	Screw-HH
30	103-0384	6	Spacer
31	103-0374	2	Retainer-Band, Brake

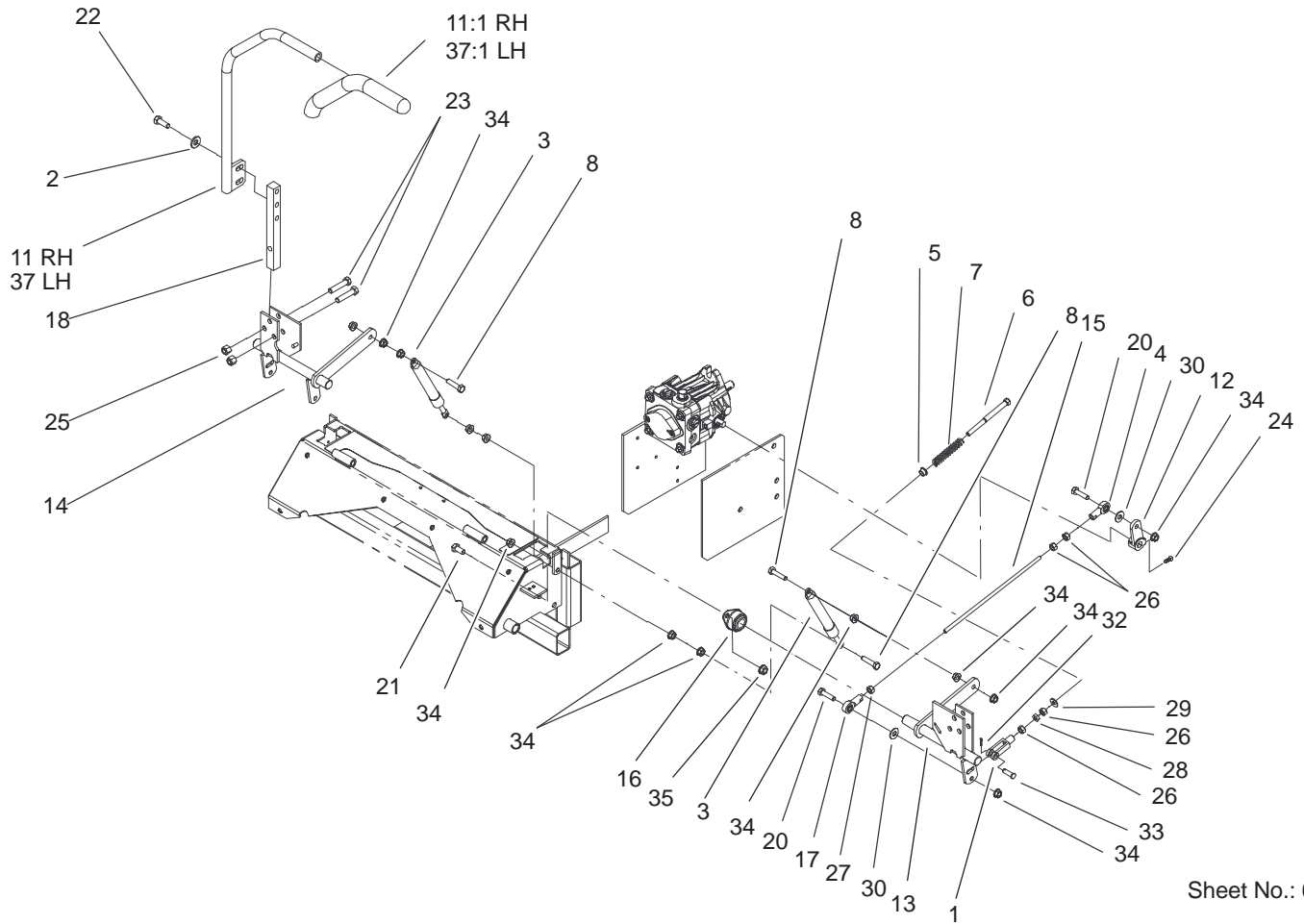

Sheet No.: 6

Steering Control Assembly

Ref. No.	Part No.	Qty.	Description
1	1-303105	2	Yoke-Adjustable
2	98-5975	4	Washer-Belleville
3	1-523027	2	Damper-Control
4	1-543017	2	Balljoint-RH
5	1-603735	2	Bushing-Flanged
6	1-603737	2	Bolt-Return, Neutral
7	1-603807	2	Spring-Return, Neutral
8	1-403180	4	Screw-HH
11	103-0632	1	RH Lever ASM
11:1	1-633257	1	Grip-Control, Motion
12	1-632208	2	Arm-Control, Pump
13	1-642319	1	Control-Motion, LH
14	1-642320	1	Control-Motion, RH
15	1-633153	2	Linkage-Pump/Lever
16	1-633102	4	Bearing-Flange, Side
17	1-633152	2	Balljoint-Thread, LH
18	103-0407	2	Arm-Shaft, Control
20	322-6	4	Screw-HH
21	323-4	8	Screw-HH
22	323-6	4	Screw-HH
23	323-9	6	Screw-HH
24	1-803022	2	Screw
25	3296-39	6	Nut-Lock, NI
26	3219-2	10	Nut-Hex
27	1-804524	2	Nut

Ref. No.	Part No.	Qty.	Description
28	3220-2	2	Nut
29	3256-2	2	Washer-Flat
30	3256-3	4	Washer-Flat
32	3272-5	2	Pin-Cotter
33	1-808280	2	Pin-Clevis
34	32128-20	16	Nut-HF
35	3290-357	8	Nut-HHF
37	103-0631	1	LH Lever ASM
37:1	1-633257	1	Grip-Control, Motion

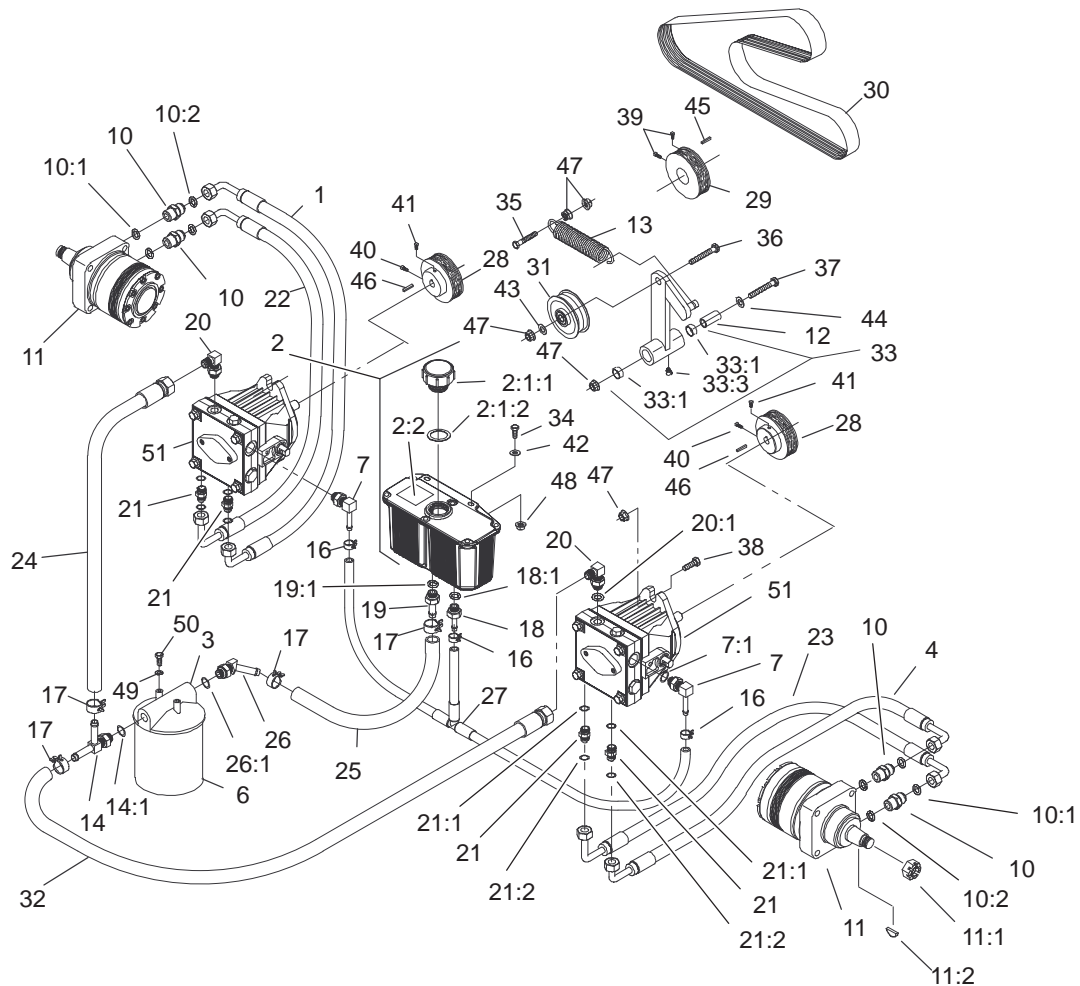

Sheet No.: 7

Hydraulic System Assembly

Ref. No.	Part No.	Qty.	Description
1	103-1764	1	Upper RH Hose ASM
2	103-1947	1	HYD Reservoir ASM
☆2:1		1	Reservoir-HYD
2:1:1	103-1948	1	Cap-HYD Reservoir
2:1:2	103-1949	1	Gasket-Cap
2:2	1-523552	1	Decal-Tank, Hydraulic
3	104-7836	1	Head-Filter
4	103-1682	1	Upper LH Hose ASM
6	1-633750	1	Filter-HYD
6	1-633752	1	Filter-HYD, Winter
7	103-1799	2	Elbow-90°
7:1	237-42	1	O-Ring
10	1-603991	4	Fitting-Straight
10:1	237-80	1	O-Ring
10:2	1-603992	1	O-Ring
11	1-523328	2	Motor-Wheel
11:1	1-809036	1	Nut-HH
11:2	3257-42	1	Key-Woodruff
*11:99	103-2748	1	Kit-Link, Drive
*11:99	1-000139	1	Kit-Bearing
*11:99	1-000099	1	Kit-Seal
12	1-603384	1	Bushing-Pivot, Idler
13	1-633151	1	Spring-Extension
14	103-1828	1	Adapter, Run Tee
14:1	237-42	1	O-Ring
16	103-1716	3	Clamp-Hose

Ref. No.	Part No.	Qty.	Description
17	103-1988	4	Clamp-Hose
18	103-1801	1	Adapter-Straight
18:1	237-42	1	O-Ring
19	103-1912	1	Adapter-Straight
19:1	237-42	1	O-Ring
20	103-1802	2	Elbow-90°
20:1	237-42	1	O-Ring
21	1-603990	4	Fitting-Straight
21:1	237-79	1	O-Ring
21:2	1-603992	1	O-Ring
22	103-1765	1	Lower RH Hose ASM
23	103-1683	1	Lower LH Hose ASM
24	103-1826	1	HYD Hose ASM
25	103-1808	1	Hose-HYD
26	103-1807	1	Elbow-45°
26:1	237-42	1	O-Ring
27	103-1806	1	HYD Hose ASM
28	1-633568	2	Sheave
29	1-633567	1	Sheave
30	1-633749	1	Belt-Drive, Pump
31	1-633167	1	Sheave-Idler
32	103-1827	1	HYD Hose ASM
33	1-634277	1	Bearing Arm ASM
33:1	1-513034	2	Sleeve-Bearing
33:3	302-40	1	Fitting-Grease
34	321-6	2	Screw-HH

☆ Not serviced separately

* Not illustrated

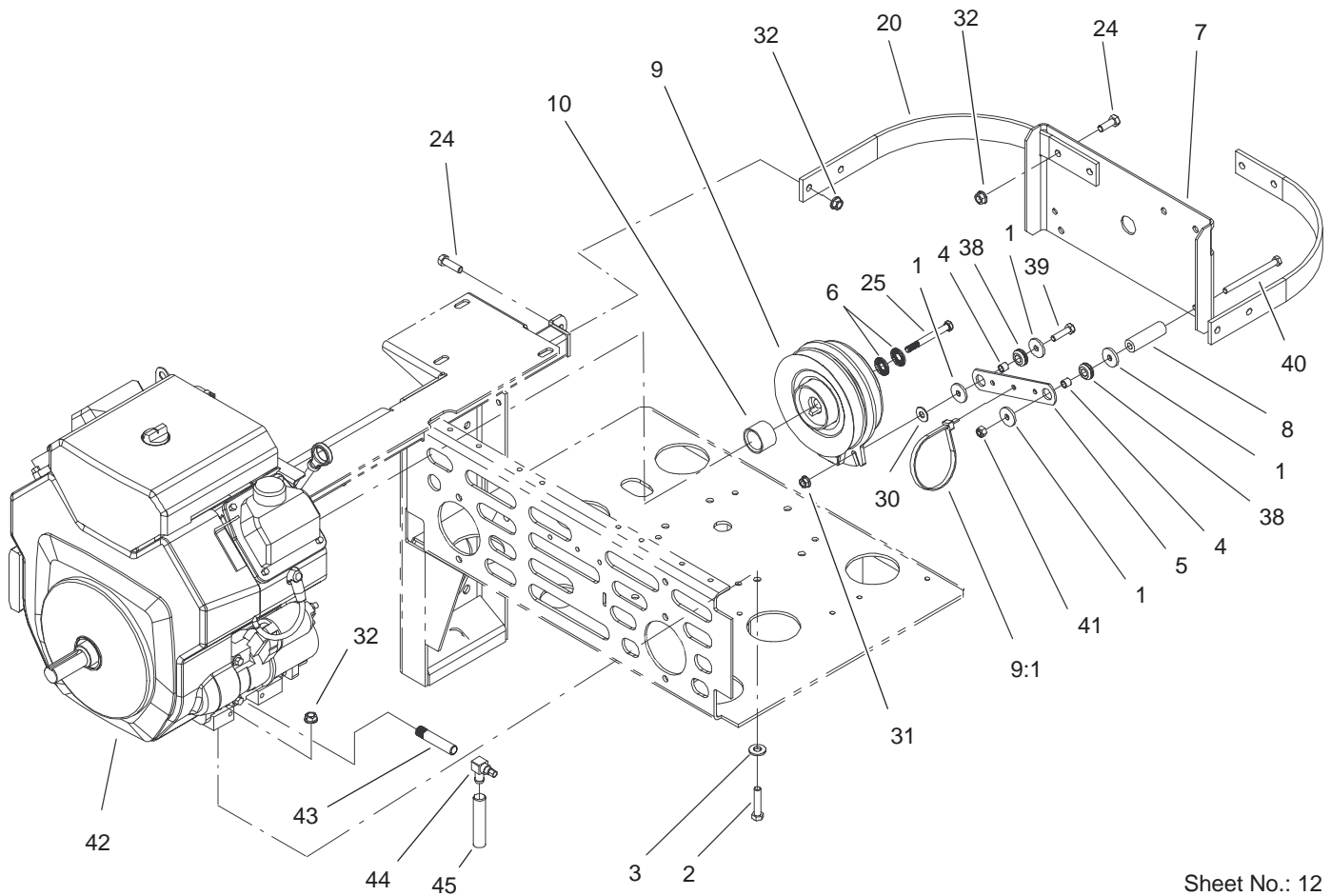

Sheet No.: 12

Engine and Clutch Assembly

Ref. No.	Part No.	Qty.	Description
1	1-613235	4	Washer
2	323-9	4	Screw-HH
3	98-5975	4	Washer-Belleville
4	1-633545	2	Spacer-Grommet
5	1-633543-03	1	Strap-Clutch, Brake
6	1-603610	2	Washer-Spring
7	1-633615-03	1	Guard-Clutch
8	1-633988	1	Spacer-Anchor, Clutch
9	103-1364	1	Clutch
9:1	1-303335	1	Tie-Plastic
10	1-633179	1	Spacer-Clutch
20	1-643264-03	2	Bracket-Guard, Top
24	323-6	6	Screw-HH
25	3212-6	1	Screw-HH
30	3256-3	1	Washer-Flat
31	32128-20	1	Nut-HF
32	3290-357	8	Nut-HHF
38	1-633630	2	Grommet-Brake
39	322-6	1	Screw-HH
40	322-19	1	Screw-HH
41	3296-29	1	Nut-Lock, NI
☆42		1	Engine-Kawasaki, FH721D AS-05
43	103-1966	1	Adapter

Ref. No.	Part No.	Qty.	Description
44	103-1965	1	Valve-Drain, Oil
45	103-1964	1	Hose, Oil Drain

☆ Not serviced separately

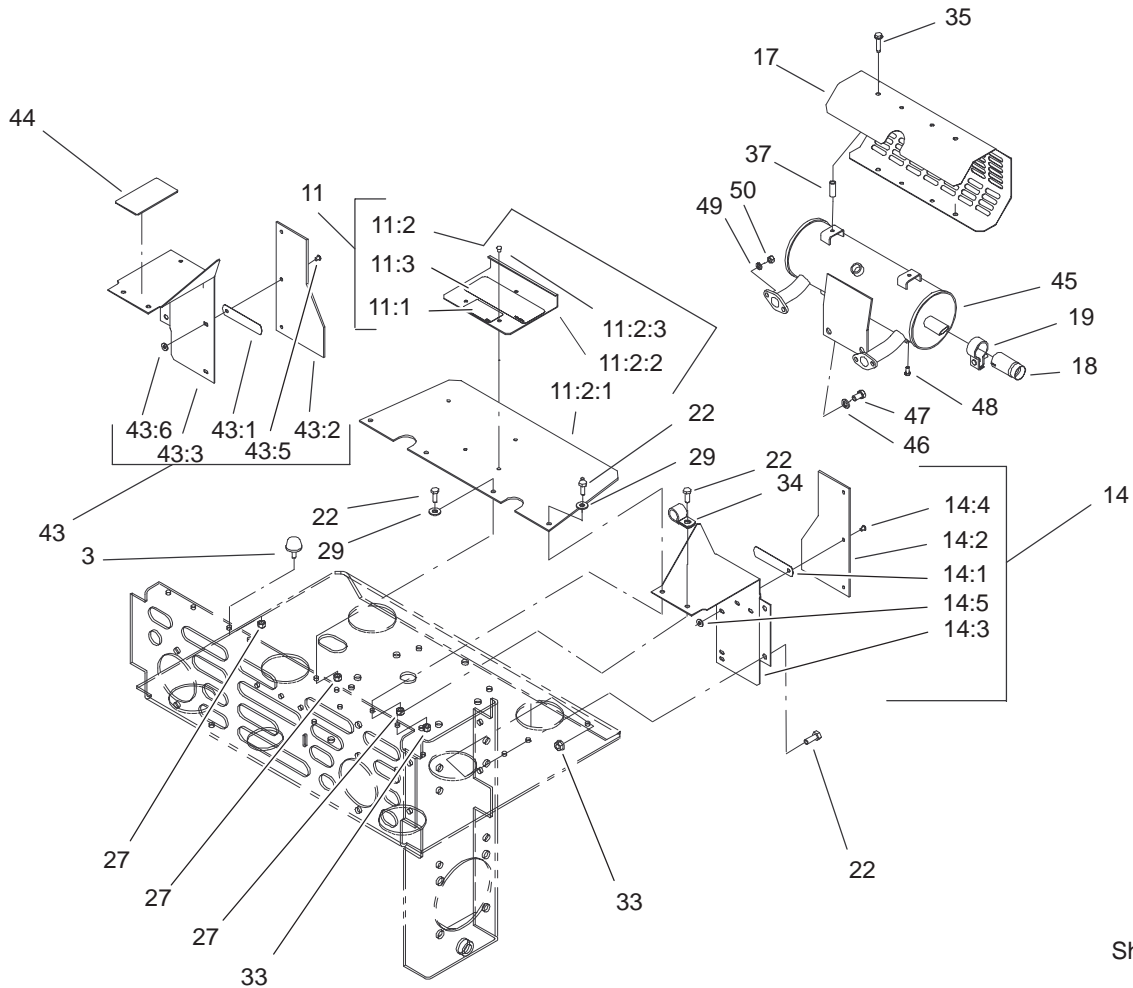

Sheet No.: 13

Guard Assembly

Ref. No.	Part No.	Qty.	Description
3	1-523420	2	Bumper
11	105-6196	1	Shield ASM W/ Decals
11:1	1-633462	1	Decal-Important
11:2	103-1301	1	Drive Cover ASM
11:2:1	103-1308	1	Shield-Engine
11:2:2	103-1304-03	1	Plate, Drive Cover
11:2:3	1-803035	5	Rivet-Pop
11:3	103-0368	1	Decal-Devices, Rotating
14	103-0241	1	LH Extended Shield ASM
14:1	1-523285	2	Clip-Baffle, Rear
14:2	103-0243	1	Shield, Engine/Pump Drive
14:3	1-633795-03	1	Baffle-Engine Shield, LH
14:4	1-803035	3	Rivet-Pop
14:5	3256-63	3	Washer-Flat
17	1-643313-03	1	Guard-Muffer
18	103-1513	1	Arrester-Spark
19	103-1514	1	Clamp-Muffer
22	321-4	10	Screw-HH
27	3296-42	6	Nut-Lock, NI
29	3256-2	4	Washer-Flat
33	32128-33	5	Nut-HF
34	1-633396	1	Clip-Loom

Ref. No.	Part No.	Qty.	Description
35	1-809108	2	Screw-HWH
37	1-323236	2	Spacer
43	103-0242	1	RH Extended Shield ASM
43:1	1-523285	2	Clip-Baffle, Rear
43:2	103-0243	1	Shield, Engine/Pump Drive
43:3	1-633794-03	1	Baffle-Engine Shield, RH
43:5	1-803035	3	Rivet-Pop
43:6	3256-63	3	Washer-Flat
44	1-643339	1	Decal-Routing, Belt
45	103-0202	1	Muffer
46	3253-6	2	Washer-Lock
47	324-2	2	Screw-HH
48	9266934	2	Screw
49	1-805005	4	Washer-Lock
50	33014-00	4	Nut-Hex

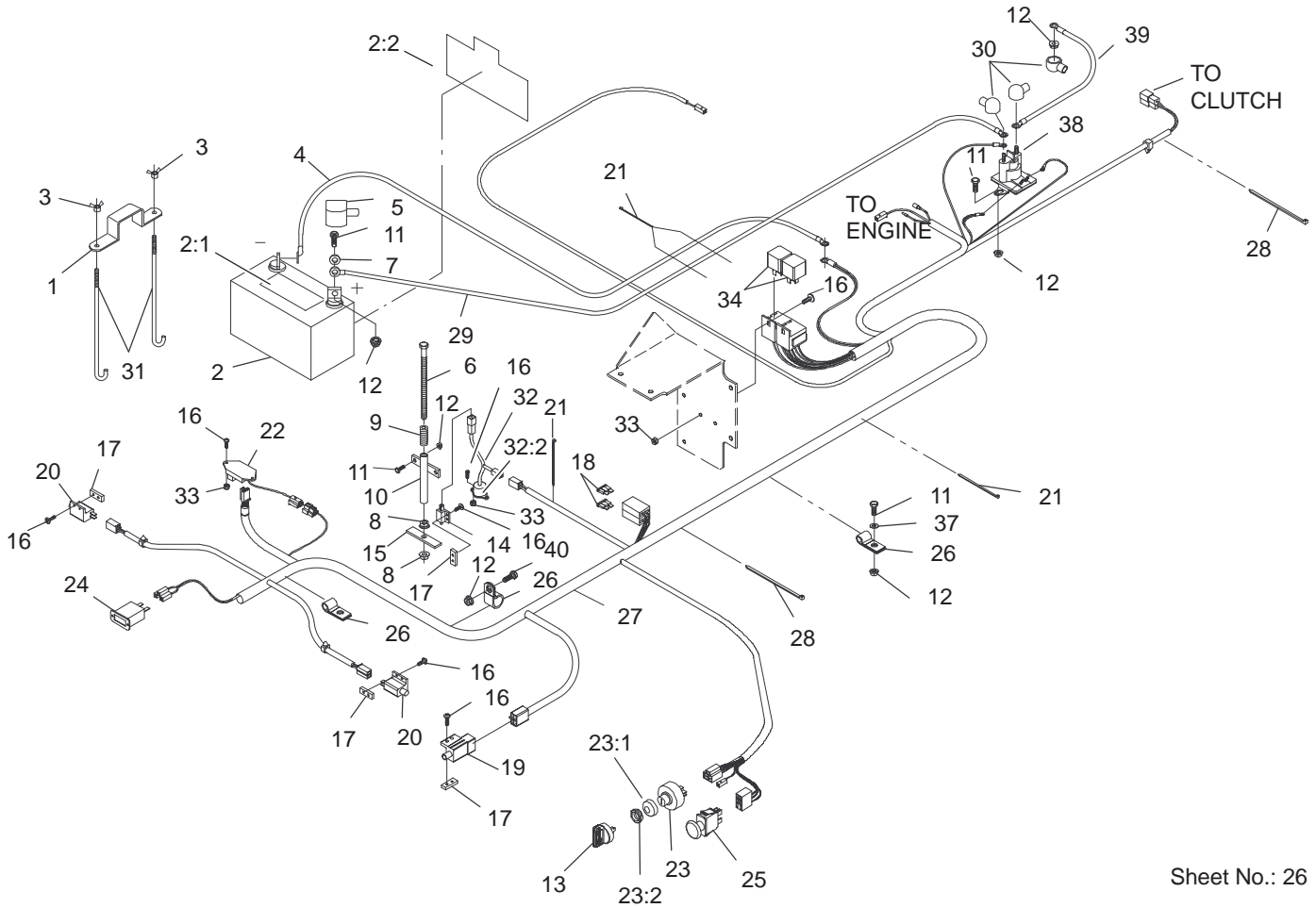

Sheet No.: 26

Electrical System Assembly

Ref. No.	Part No.	Qty.	Description
1	1-633652-03	1	Strap-Holddown, Battery
2	105-1692	1	Battery
2:1	104-4163	1	Decal-Battery
2:2	104-4164	1	Decal-Battery
3	1-543792	2	Wingnut
4	1-633307	1	Wire-Ground
5	1-543391	1	Insulator-Battery
6	1-800282	1	Screw-HH
7	3256-2	2	Washer-Flat
8	32128-20	2	Nut-HF
9	1-523415	1	Spring-Switch, Seat
10	1-522424-03	1	Mount-Spring, Seat
11	321-4	8	Screw-HH
12	32128-33	8	Nut-HF
13	63-8360	2	Key-Ignition
14	1-513152	1	Switch-Closed, Normally
15	1-513180	1	Plate-Switch, Seat
16	3290-500	14	Screw-PPH
17	1-633181	4	Plate-Tapped
18	1-816001	2	Fuse-Type, Blade
19	1-633111	1	Switch
20	1-513051	2	Switch-Open, Normally
21	1-303287	5	Tie-Plastic

Ref. No.	Part No.	Qty.	Description
22	100-6186	1	Module-Delay, Seat
23	88-9830	1	Key Switch ASM
23:1	3254-5	1	Washer-Lock, Internal
23:2	218-461	1	Nut-HH
24	1-513374	1	Meter-Hour
25	1-633673	1	Switch-Delta
26	1-633396	3	Clip-Loom
27	105-3191	1	Harness-Wire
28	1-303335	2	Tie-Plastic
29	1-523281	1	Wire-Starter
30	1-543393	3	Insulator-Solenoid
31	1-633651	2	Bolt-Holddown
32	1-644427	1	Tilt Switch ASM
32:2	1-643401	1	Decal-Switch, Mercury
33	3296-2	6	Nut-Lock
34	1-643275	2	Relay
37	3256-22	1	Washer-Flat
38	1-513075	1	Switch-Solenoid
39	1-633306	1	Wire-Starter
40	321-2	1	Screw-HH

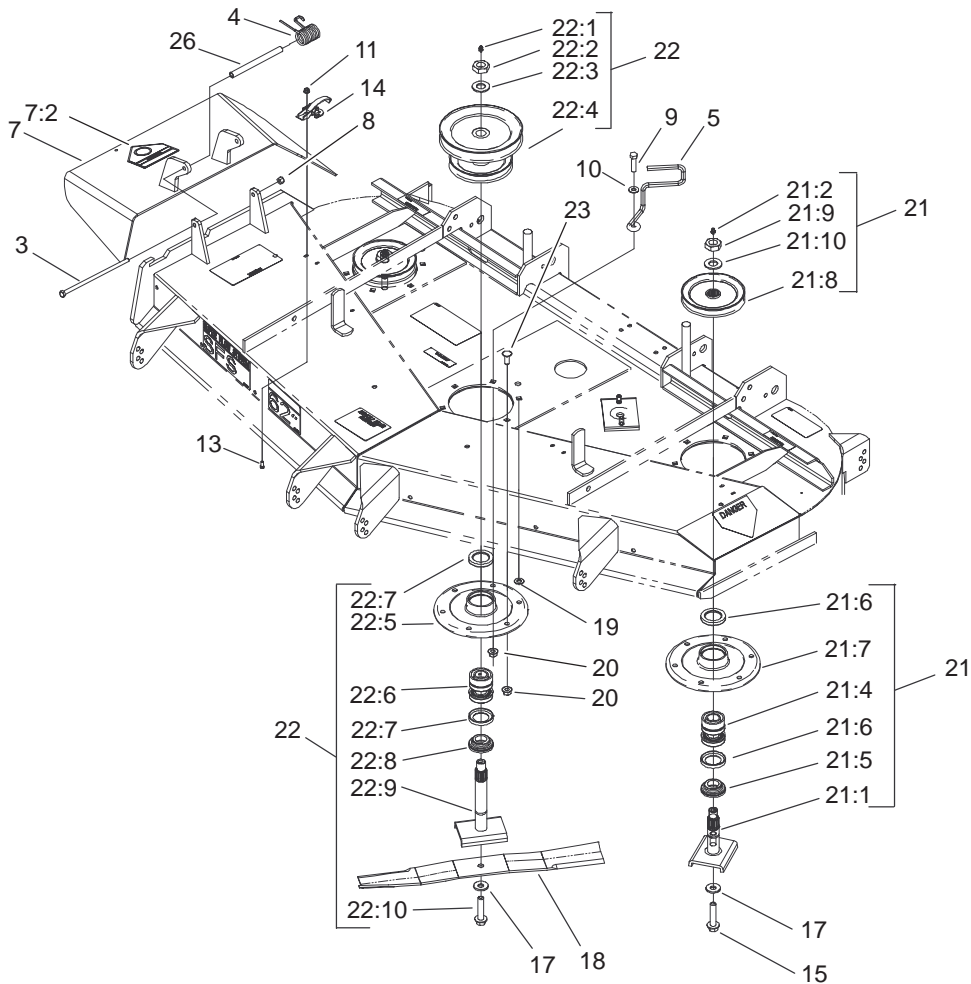

Sheet No.: 62

Spindle and Pulley Assembly

Ref. No.	Part No.	Qty.	Description
3	322-50	1	Screw-Cap
4	104-8554	1	Spring-Torsion
5	99-8933	1	Guide-Belt
7	105-3605	1	Deflector ASM
7:2	54-9220	1	Decal-Danger
8	3296-29	1	Nut-Lock, NI
9	323-8	1	Screw-HH
10	3256-3	1	Washer-Flat
11	32128-17	8	Nut-Lock, Flange
13	3290-321	8	Screw-HWH
14	249-21	4	Clamp-Slotted
15	92-5816	2	Bolt-Blade
17	1-513435	3	Washer-Spring
18	44-6250	3	Blade
19	3256-24	1	Washer-Flat
20	32128-21	18	Nut-HF
21	99-4640	2	Outer Spindle ASM
21:1	27-0920	1	Shaft-Spindle
21:2	302-2	1	Fitting-Grease
21:4	46-8530	1	Bearing ASM
21:5	27-0950	1	Spacer-Bearing, Spindle
21:6	253-139	2	Seal-Oil
21:7	61-4160	1	Housing-Spindle
21:8	99-4614	1	Pulley & Hub
21:9	32146-20	1	Nut-Jam

Ref. No.	Part No.	Qty.	Description
21:10	7-4150	1	Washer-Pinion
22	105-1688	1	Spindle Housing ASM
22:1	302-2	1	Fitting-Grease
22:2	32146-20	1	Nut-Jam
22:3	92-5836	1	Washer-Axle
22:4	99-4939	1	Pulley & Hub ASM
22:5	61-4160	1	Housing-Spindle
22:6	46-8530	1	Bearing ASM
22:7	253-139	2	Seal-Oil
22:8	27-0950	1	Spacer-Bearing, Spindle
22:9	105-1686	1	Spindle Shaft ASM
22:10	92-5816	1	Bolt-Blade
23	3231-22	17	Screw-CARR
26	105-4622	1	Spacer-Mounting, Deflector

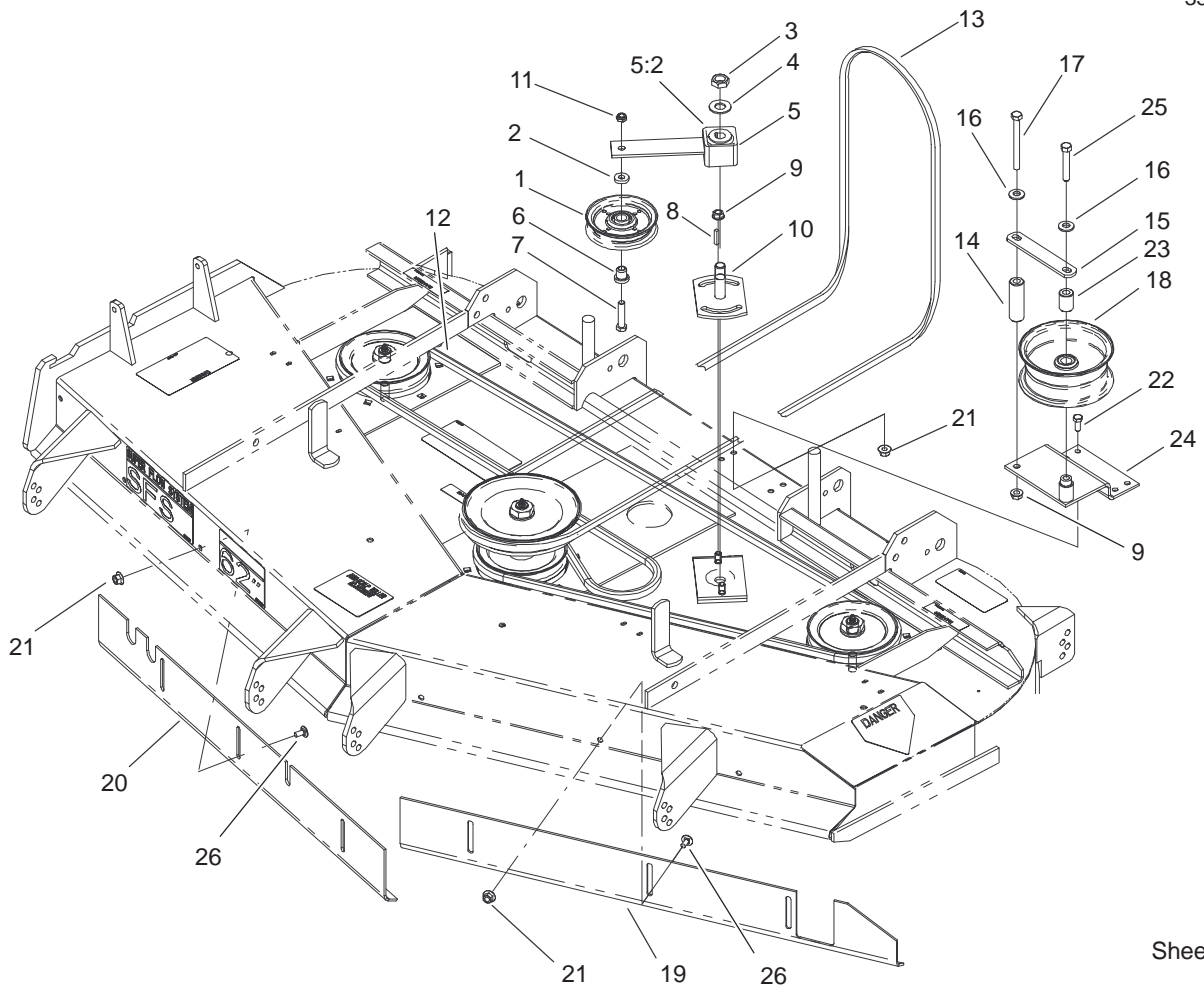

Sheet No.: 63

Belt and Idler Arm Assembly

Ref. No.	Part No.	Qty.	Description
1	65-5940	1	Pulley-Idler
2	7-0081	1	Washer-Flat
3	3296-71	1	Nut-Lock NI
4	3256-27	1	Washer-Flat
5	27-8580	1	Idler Socket & Bushing ASM
5:2	27-8490	1	Bushing-Rubber, Idler
6	65-5950	1	Bushing-Pulley
7	3211-8	1	Screw-HH
8	5-1077	1	Key-Square
9	3290-357	3	Nut-HHF
10	44-6301	1	Plate-Idler, LH
11	3296-5	1	Nut-Lock, NI
12	44-6260	1	V-Belt
13	99-4647	1	V-Belt-Drive, Deck
14	99-4659	1	Spacer-Bracket
15	1-653189	1	Plate-Guide, Belt
16	98-5975	2	Washer-Belleville
17	323-42	1	Screw-HH
18	1-413099	1	Pulley-Idler
19	99-2833-03	1	Baffle-Front, LH
20	99-2834-03	1	Baffle-Front, RH
21	32128-20	10	Nut-HF
22	322-3	4	Screw-HH
23	1-653190	1	Spacer
24	99-4684-01	1	Bracket-Pulley

Ref. No.	Part No.	Qty.	Description
25	323-11	1	Screw-HH
26	3230-18	6	Screw-CARR

Electrical Schematic

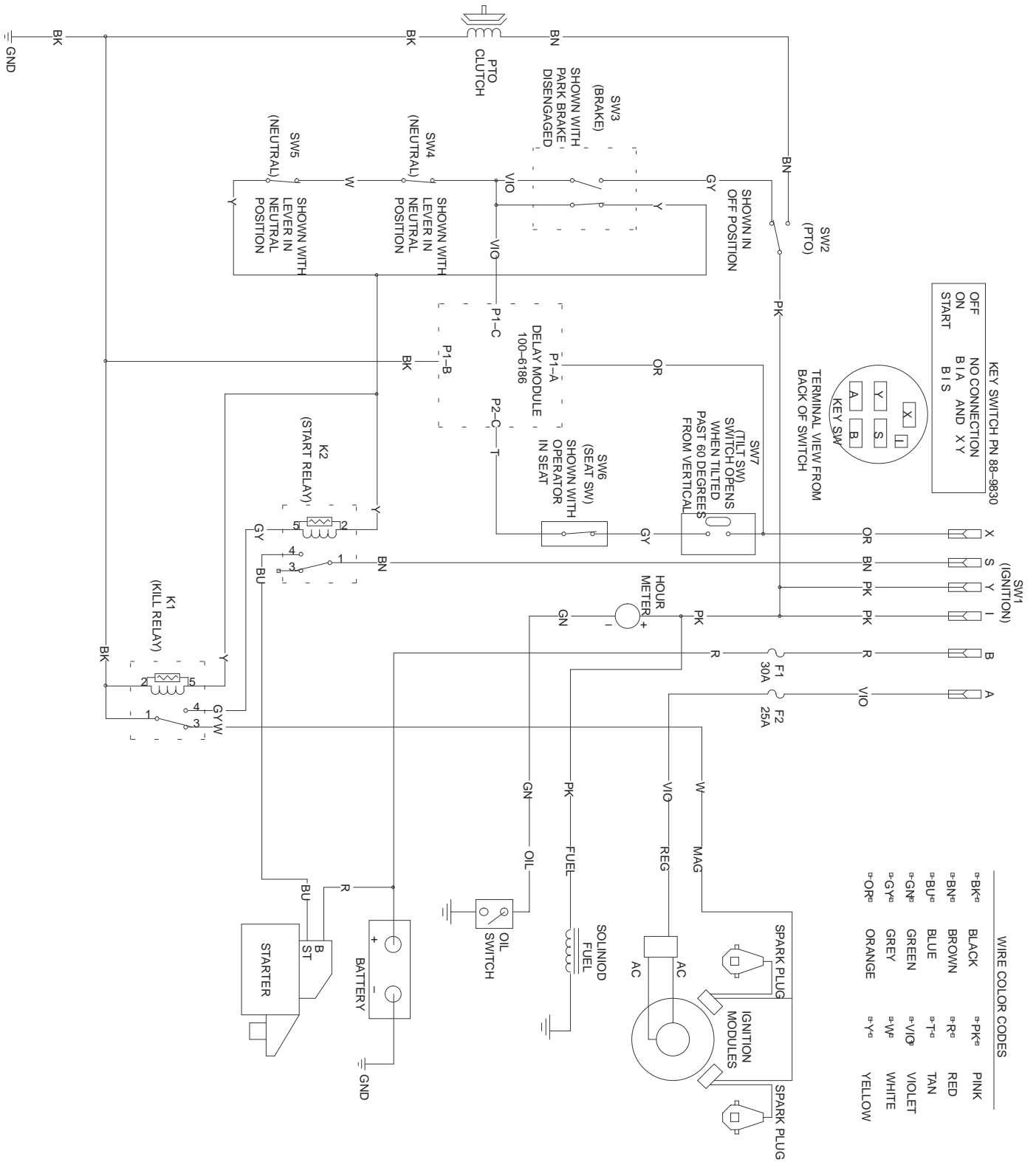

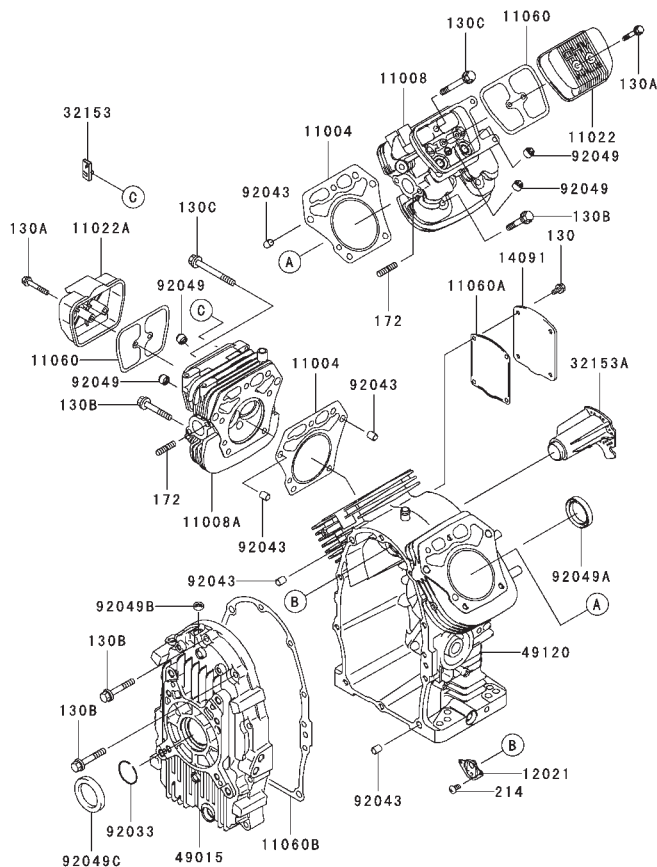

Cylinder/Crankcase Assembly Kawasaki FH721D-AS05

Ref. No.	Part No.	Qty.	Description
11004	11004-7004	2	Gasket-Head
11008	11008-7004	1	Head-Comp
11008A	11008-7007	1	Cylinder #2
11022	11022-7002	1	Head-Comp
11022A	11022-7004	1	Cylinder #1
11060	11060-7013	2	Case-Rocker
11060A	11060-7014	1	Case-Rocker
11060B	11060-7023	1	Gasket-Rocker, Case
12021	12021-7002	1	Gasket-Breather
14091	14091-7004	1	Gasket-Crankcase
32153	32153-7003	1	Reed Valve ASM
32153A	32153-7004	1	Cover
49015	49015-6234	1	Pipe
49120	49120-6135	1	Pipe
92033	92033-7004	1	Cover-Crankcase
92043	92043-7001	6	Crankcase-Comp
92049	92049-7001	4	Ring-Snap
92049A	92049-7002	1	Pin
92049B	92049-7005	1	Seal-Oil
92049C	92049-7007	1	Seal-Oil
130	130B0612	4	Seal-Oil
130A	130B0640	4	Bolt-Flanged

Ref. No.	Part No.	Qty.	Description
130A	130B0640	4	Bolt-Flanged
130B	130T0850	18	Bolt-Flanged
130C	130T0875	2	Bolt-Flanged
172	172G0818	4	Bolt-Stud
214	214B0408	2	Screw-Pan

Obtain Parts From Kawasaki

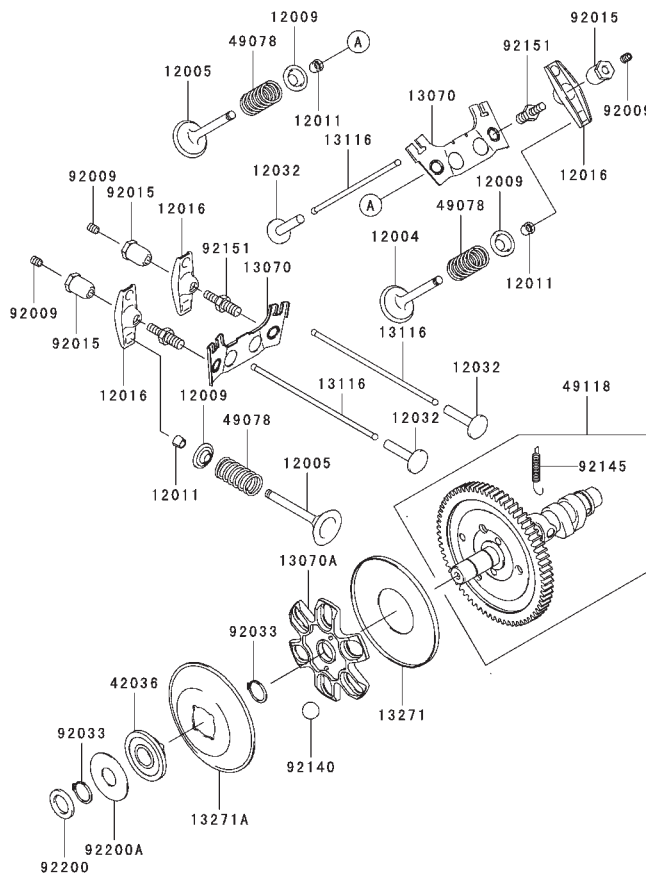

Valve/Camshaft Assembly Kawasaki FH721D-AS05

Ref. No.	Part No.	Qty.	Description
12004	12004-7002	2	Valve-Intake
12005	12005-7002	2	Valve-Exhaust
12009	12009-7001	4	Retainer-Valve Spring
12011	12011-2056	8	Collet
12016	12016-7006	4	Arm-Rocker
12032	12032-7001	4	Tappet
13070	13070-7007	2	Guide
13070A	13070-7008	1	Arm-Rocker
13116	13116-7002	4	Rod-Push
13271	13271-7007	1	Plate
13271A	13271-7021	1	Plate
42036	42036-7001	1	Sleeve
49078	49078-7002	4	Spring-Engine Valve
49118	49118-7007	1	Camshaft-Comp
92009	92009-2341	4	Screw
92015	92015-2253	4	Nut
92033	92033-7001	2	Ring-Snap
92140	92140-7002	6	Ball
92145	92145-7001	1	Spring
92151	92151-7019	4	Bolt
92200	92200-7001	1	Washer
9200A	92200-7009	1	Washer

Ref. No.	Part No.	Qty.	Description

Obtain Parts From Kawasaki

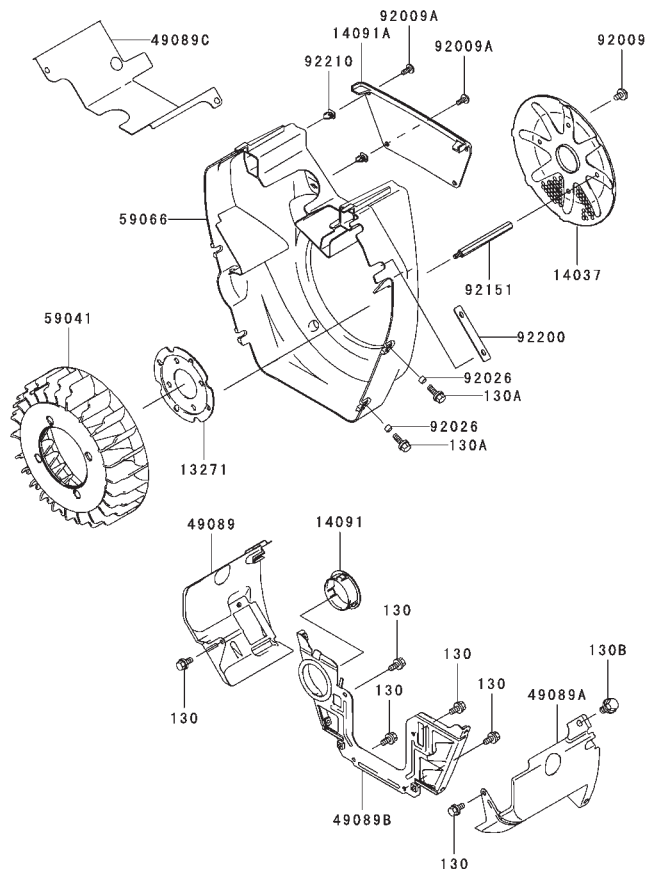

Cooling Equipment Assembly Kawasaki FH721D-AS05

Ref. No.	Part No.	Qty.	Description	Ref. No.	Part No.	Qty.	Description
13271	13271-7015	1	Plate				
14037	14037-7014	1	Screen				
14091	14091-7002	1	Cover				
14091A	14091-7005	1	Cover				
49089	49089-7004	1	Shroud-Engine				
49089A	49089-7005	1	Shroud-Engine				
49089B	49089-7015	1	Shroud-Engine				
49089C	49089-7019	1	Shroud-Engine				
59041	59041-7004	1	Fan				
59066	59066-7005	1	Housing-Fan				
92009	92009-7008	4	Screw				
92009	92009-7009	4	Screw				
92026	92026-7001	4	Spacer				
92151	92151-7018	4	Bolt				
92200	92200-7011	1	Washer				
92210	92210-7011	4	Nut				
130	130B0612	2	Bolt-Flanged				
130A	130B616	4	Bolt-Flanged				
130B	130B0816	2	Bolt-Flanged				

Obtain Parts From Kawasaki

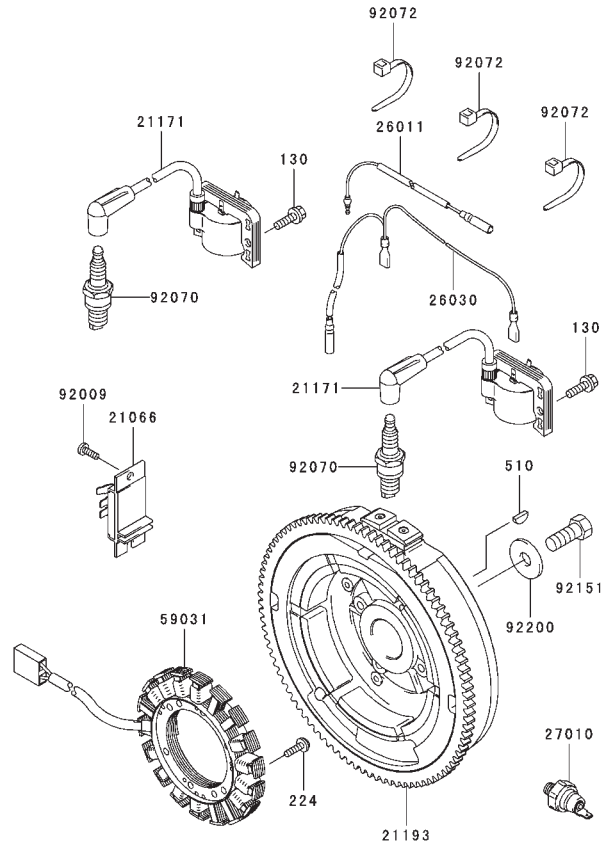

Electric Equipment Assembly Kawasaki FH721D-AS05

Ref. No.	Part No.	Qty.	Description
21066	21066-7003	1	Regulator-Voltage
21171	21171-7001	2	Ignition Coil ASM
21193	21193-7014	1	Flywheel ASM
26011	26011-7008	1	Wire-Lead
26030	26030-7002	1	Harness
27010	27010-7001	1	Switch
59031	59031-7001	1	Coil-Charging
92009	92009-2308	1	Screw
92070	92070-7004	2	Plug-Spark
92072	92072-7003	3	Band
92151	92151-2097	1	Bolt
92200	92200-7002	1	Washer
130	130B0620	4	Bolt-Flanged
224	224B0520	4	Screw-Pan
510	510A5100	1	Key-Woodruff

Ref. No.	Part No.	Qty.	Description

Obtain Parts From Kawasaki

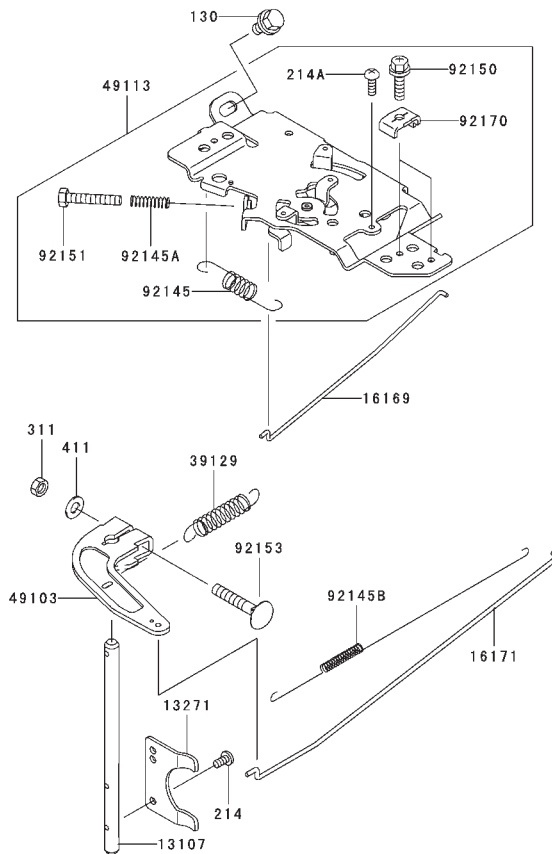

Control Equipment Assembly Kawasaki FH721D-AS05

Ref. No.	Part No.	Qty.	Description
13107	13107-7011	1	Shaft
13271	13271-7018	1	Plate
16169	16169-7008	1	Link-Choke
16171	16171-7005	1	Link
39129	39129-7004	1	Spring-Governor
49103	49103-7004	1	Arm-Governor
49113	49113-7015	1	Panel-Comp-Control
92145	92145-7004	1	Spring
92145A	92145-7005	1	Spring
92145B	92145-7014	1	Spring
92150	92150-2182	2	Bolt
92151	92151-7014	1	Bolt
92153	92153-7005	1	Bolt
92170	92170-7001	2	Clamp
130	130B0612	2	Bolt-Flanged
214	214B0408	2	Screw-Pan
214A	214B0412	1	Screw-Pan
311	311B0600	1	Nut-Hex
411	411B0600	1	Washer

Ref. No.	Part No.	Qty.	Description

Obtain Parts From Kawasaki

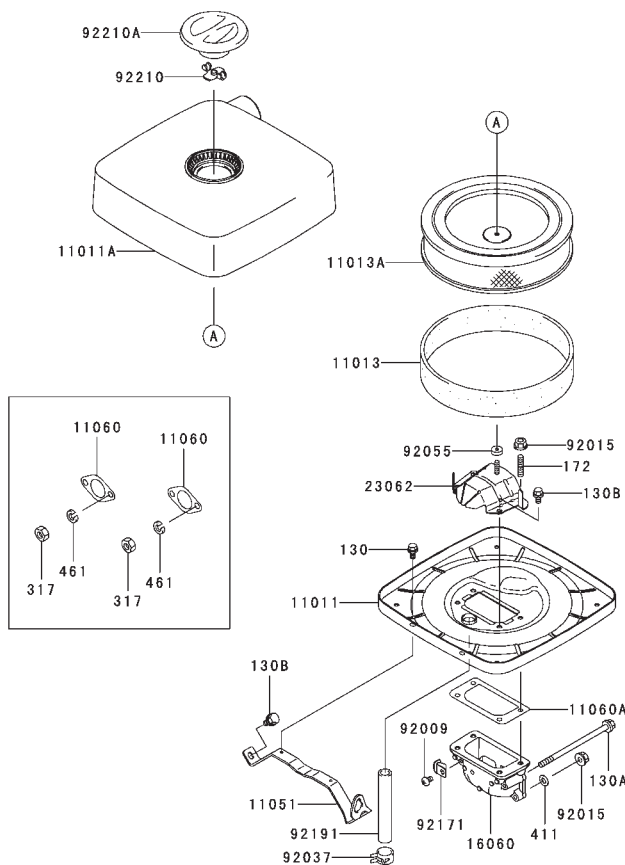

Air Filter/Muffler Assembly Kawasaki FH721D-AS05

Ref. No.	Part No.	Qty.	Description
11011	11011-7004	1	Case-Air Filter
11011A	11011-7005	1	Case-Air Filter
11013	11013-7007	1	Element-Air Filter
11013A	11013-7011	1	Element-Air Filter
11051	11051-7007	1	Bracket
11060	11060-7016	2	Gasket-Muffler
11060A	11060-7022	1	Gasket-A/C Case
16060	16060-7002	1	Pipe-Intake
23062	23062-7006	1	Bracket-Comp
92009	92009-2166	1	Screw
92015	92015-1193	4	Nut
92037	92037-2079	1	Clamp
92055	92055-7005	1	O-Ring
92171	92171-7003	1	Clamp
92191	92191-7020	1	Tube
92210	92210-7004	1	Nut
92210A	92210-7010	1	Nut
130	130B0510	2	Bolt-Flanged
130A	130B0615	2	Bolt-Flanged
130B	130B0612	4	Bolt-Flanged
172	172G0612	2	Bolt-Stud
317	317R0800	4	Nut-Hex
411	411B0600	1	Washer
461	461F0800	4	Washer-Spring

Ref. No.	Part No.	Qty.	Description

Obtain Parts From Kawasaki

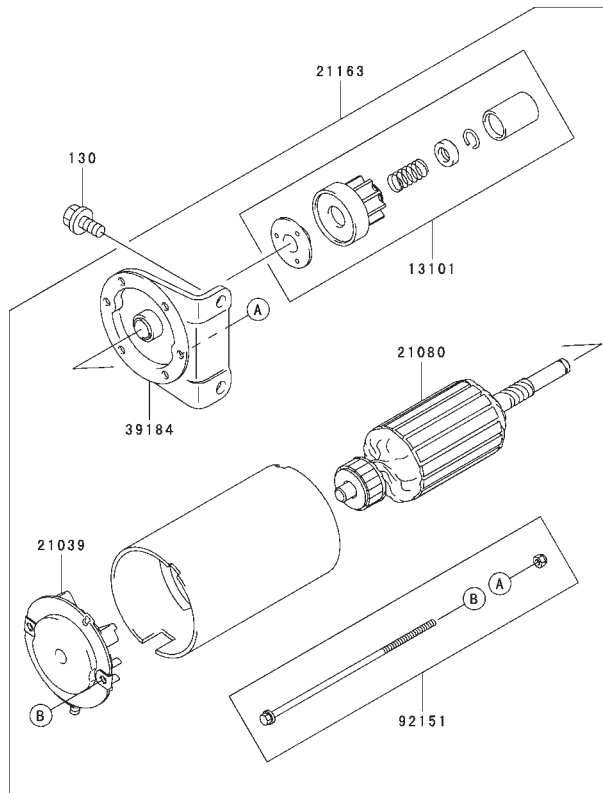

Starter Assembly Kawasaki FH721D-AS05

Ref. No.	Part No.	Qty.	Description
13101	13101-7001	1	Gear ASM
21039	21039-7001	1	Brush
21080	21080-7001	1	Armature
211636	21163-7001	1	Starter-Electric
39184	39184-7001	1	Bracket ASM
92151	92151-7013	1	Bolt
130	130B0816	2	Bolt-Flanged

Ref. No.	Part No.	Qty.	Description

Obtain Parts From Kawasaki

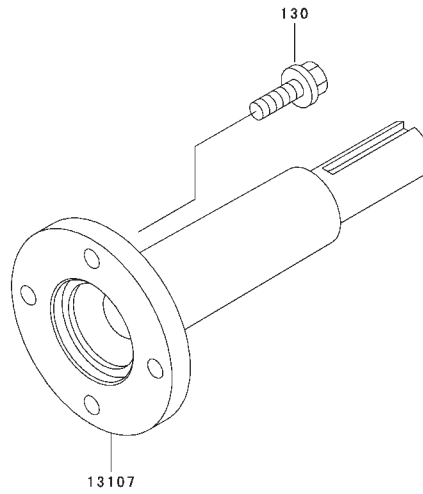

P.T.O. Equipment Assembly Kawasaki FH721D-AS05

Ref. No.	Part No.	Qty.	Description
13107	13107-7014	1	Shaft
130	130B0825	4	Bolt-Flanged

Ref. No.	Part No.	Qty.	Description

Obtain Parts From Kawasaki

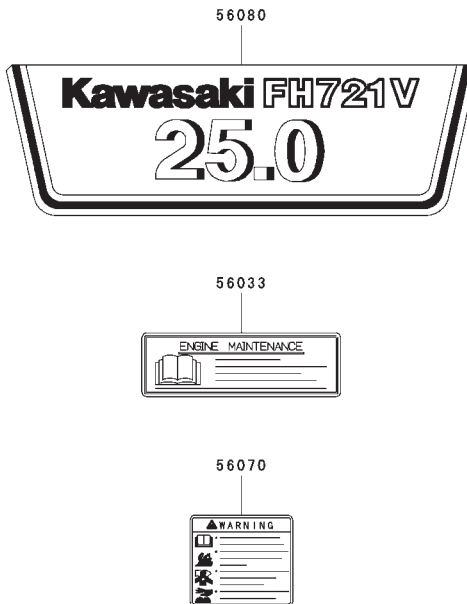

Label Assembly Kawasaki FH721D-AS05

Ref. No.	Part No.	Qty.	Description
56033	56033-7001	1	Label-Manual
56070	56070-7001	1	Label-Warning
56080	56080-7013	1	Label-Brand

Ref. No.	Part No.	Qty.	Description

Obtain Parts From Kawasaki

