



**8-Blade and 11-Blade Single Point Adjustment
Reel Mower**

Greensmaster[®] 3000 Series

Model No. 04450—Serial No. 220000001 and Up

Model No. 04468—Serial No. 220000001 and Up

Operator's Manual



Contents

	Page
Introduction	2
Safety	3
Safety and Instruction Decals	3
Optional Equipment	3
Setup	4
Loose Parts	4
Leveling the Rear Roller to the Reel	4
Adjusting the Height of Cut	6
Adjusting the Shield Height	6
Adjusting the Top Bar	6
Operation	7
Maintenance	7
Lubrication	7
Reel Lapping	8
Removing the Bedknife	8
Installing the Bedknife	9
Parallel the Bedknife to the Reel	9
Preparing the Reel for Grinding	10
Servicing and Adjusting the Reel Bearings	11
Removing the Reel Assembly	11
The Toro General Commercial Products Warranty ..	12

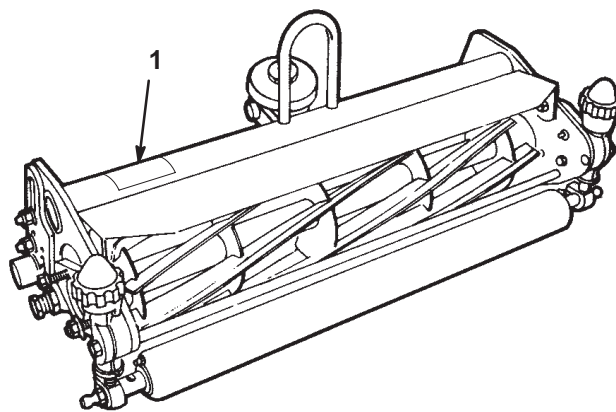

Figure 1

1. Model and serial number plate

Write the product model and serial numbers in the space below:

<p>Model No. _____</p> <p>Serial No. _____</p>
--

This manual identifies potential hazards and has special safety messages that help you and others avoid personal injury and even death. **Danger**, **Warning**, and **Caution** are signal words used to identify the level of hazard. However, regardless of the hazard, be extremely careful.

Danger signals an extreme hazard that *will* cause serious injury or death if you do not follow the recommended precautions.

Warning signals a hazard that *may* cause serious injury or death if you do not follow the recommended precautions.

Caution signals a hazard that may cause minor or moderate injury if you do not follow the recommended precautions.

This manual uses two other words to highlight information. **Important** calls attention to special mechanical information and **Note:** emphasizes general information worthy of special attention.

Introduction

Read this manual carefully to learn how to operate and maintain your product properly. The information in this manual can help you and others avoid injury and product damage. Although Toro designs and produces safe products, you are responsible for operating the product properly and safely.

Whenever you need service, genuine Toro parts, or additional information, contact an Authorized Service Dealer or Toro Customer Service and have the model and serial numbers of your product ready. Figure 1 illustrates the location of the model and serial numbers on the product.

Safety

Safety and Instruction Decals



Safety decals and instructions are easily visible to the operator and are located near any area of potential danger. Replace any decal that is damaged or lost.



77-0490



93-6691 (for CE)

1. Read the *Operator's Manual*.

Optional Equipment

Swaged Roller Kit	Model No. 04414
Full Roller Kit	Model No. 04412
Wiehle Roller Kit	Model No. 04424
Aluminum Wiehle Roller Kit	Model No. 04426
Low Height-of-Cut Bedknife	Part No. 93-4264
High Cut Bedknife	Part No. 62-2500
Tournament Bedknife	Part No. 93-4263
Basket Reinforcement Kit	Part No. 26-0900
Scraper Comb Assembly	Part No. 11-0700
Rear Roller Scraper Kit	Part No. 53-9240
Quick Height-of-Cut Kit	Model No. 04451
Scraper/Brush Assembly	Part No. 33-1000

Setup

Loose Parts

Description	Qty.	Use
Ball stud	2	Mounting the front roller
Internal tooth lock washer, 3/8 in.	2	
Flange locknut	2	Mounting the reel drive motor to the cutting unit
Registration card	1	Fill out and return to Toro.

1. The cutting unit is shipped without a front roller. Install the roller using the loose parts supplied with the cutting unit and the instructions included with the roller.
2. Retain the two flange nuts supplied in the loose parts for mounting the reel drive motor to the cutting unit.
3. Check for looseness in the bearings between the end plate and reel by moving the reel laterally or axially on each end of the cutting unit; refer to Servicing and Adjusting the Reel Bearings, page 11.
4. Check to make sure the bedknife and reel are parallel. On either end of the front side of the cutting unit insert a long strip of newspaper between the reel blade and the bedknife. Slowly rotate the reel and turn the bedknife adjusting knob (using a wrench) (Fig. 2) clockwise one click at a time, until the paper is pinched lightly, which results in a slight drag when the paper is pulled.

Note: The adjustment knob contains a detent with 0.001 in. (0.025 mm) movement of the bedknife for each indexed position.

Check the opposite end for light contact using paper. If light contact is not evident at both ends, the bedknife is not parallel to the reel; refer to Parallel the Bedknife to the Reel, page 9.

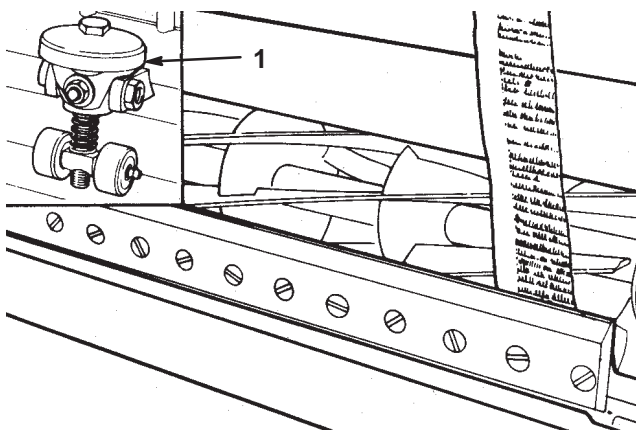

Figure 2

1. Bedknife adjusting knob

Leveling the Rear Roller to the Reel

1. Position the cutting unit on a flat, level surface.
2. Assemble the rear height-of-cut brackets to the desired position. Loosen the top capscrew and nut and remove the bottom nut and bolt on the right and left-hand sides of the cutting unit (Fig. 3).

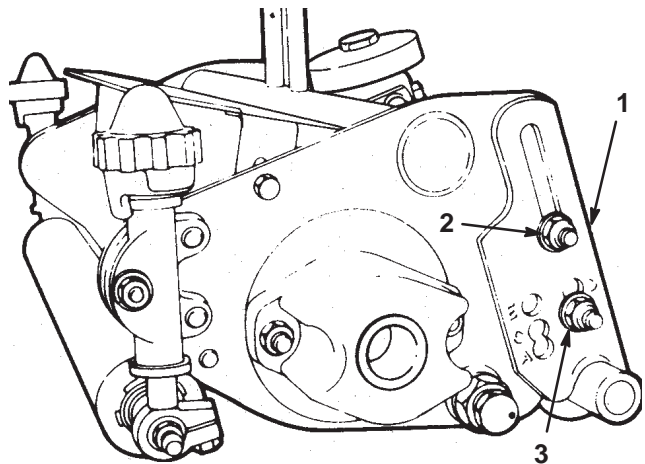

Figure 3

1. Rear height-of-cut bracket
2. Top capscrew and nut
3. Bottom nut

3. Slide the bolts through each bracket until the brackets can be realigned with the appropriate mounting hole. See table 1 for the proper position on the brackets.

Note: The various rear roller bracket positioning holes (B through E) are designed to optimize the bedknife location for different heights of cut.

To determine the correct hole setting, find the desired height of cut in the chart below and note the recommended hole position letter. The typical height-of-cut values can be used as a guide.

Table 1

Typical Height of Cut	Recommended Rear Roller Bracket Hole Positions	Height-of-Cut Ranges
1/8 in.* (3.18 mm)	B	3/32–1/4 in. (2.38–6.36 mm)
1/4 in. (6.36 mm)	C	3/16–3/8 in. (4.76–9.53 mm)
3/8 in. (9.53 mm)	D	1/4–1/2 in. (6.36–12.7 mm)
1/2 in. (12.7 mm)	E	3/8–3/4 in. (9.53–19.05 mm)

* with the appropriate bedknife

Note: For most typical greens mowing, the best rear roller location is usually the “C” position.

Note: The height of cut ranges listed have more than one possible hole position. It may be necessary to deviate outside the above suggested ranges if grass conditions warrant.

- After positioning the bolts into the correct height-of-cut hole position, install the flat washers and nuts and securely tighten the right-hand rear roller bracket capscrews (Fig. 4).

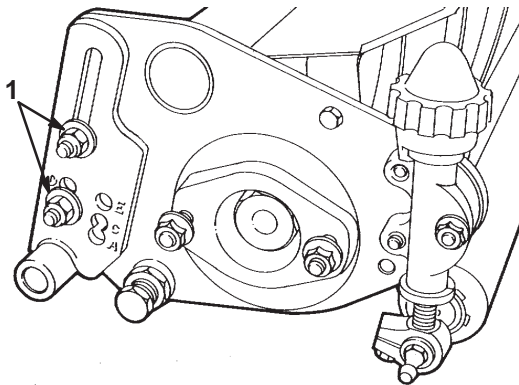

Figure 4

- Right rear roller bracket capscrews

- Tighten the left-hand rear roller bracket capscrews only enough to remove excessive looseness in the assembly but allow the bracket to slide freely on the side plate.
- Position a 1/4 in. (6.4 mm) or thicker plate under the reel blades and against the front face of the bedknife (Fig. 5).

Note: Be sure that the plate covers the full length of the reel blades, and the three blades contact the plate.

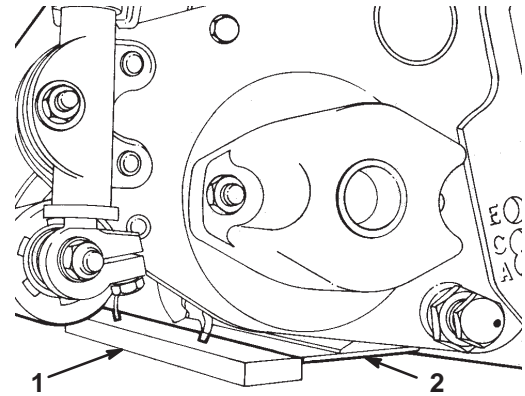

Figure 5

- 1/4 in. (6.4 mm) plate
- Bedknife

- While holding the reel securely on the plate, level the roller by rotating the lower left roller pivot bolt.

The pivot bolt has an offset thread which, when rotated, acts as a cam to raise or lower the roller. On the bolt head there is an identification dot (Fig. 6) which denotes the offset of the bolt. The dot indicates in which direction the left end of the roller moves when the bolt is turned.

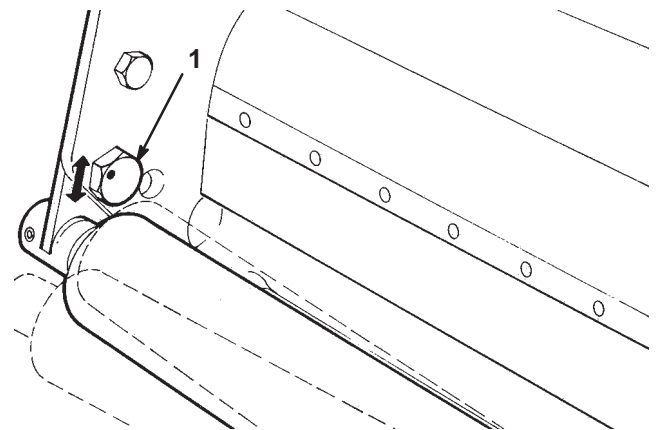

Figure 6

- Pivot bolt

- To verify that the roller is level, insert a piece of paper under each end of the roller.
- When the roller is level, tighten the left capscrew and pivot bolt securely.

Adjusting the Height of Cut

1. Verify that the rear roller brackets are in the correct hole positions corresponding with the desired height of cut and that the rear roller is level. Also, check that the bedknife to reel contact is correct (see Table 1, page 5).
2. Turn the cutting unit over and loosen the locknuts securing the front roller adjusting screws to the height-of-cut brackets (Fig. 7).

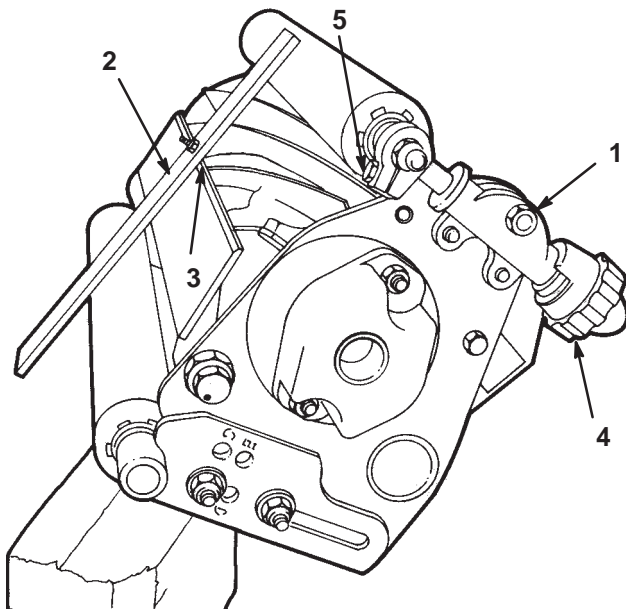

Figure 7

- | | |
|-------------------------------|----------------------------|
| 1. Height-of-cut knob locknut | 4. Height-of-cut knob |
| 2. Gauge bar (13-8199) | 5. Roller shaft clamp bolt |
| 3. Gauge bar screw head | |

3. On the gauge bar (Part No. 13-8199), set the head of the screw to the desired height of cut. This measurement is from the bar face to the underside of the screw head.
4. Place the bar across the front and rear rollers and adjust the height-of-cut knob until the underside of the screw head engages the bedknife cutting edge (Fig. 7).

Note: Turning the height-of-cut knob one turn equals 0.025 in. (0.64 mm) height-of-cut change.

Important Perform step 4 on each end of the bedknife and tighten the height-of-cut adjustment locknuts on each end.

Adjusting the Shield Height

Adjust the shield to ensure grass clipping discharge properly into the basket.

1. Set the cutting unit in the normal cutting position and measure the distance from the top of the front crossbar to the shield at each end of the cutting unit (Fig. 8).

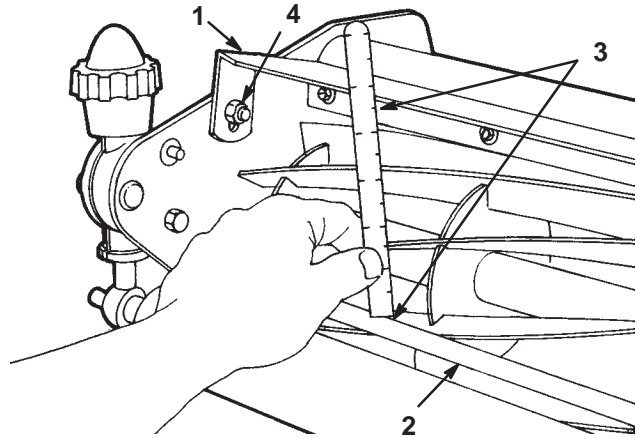

Figure 8

- | | |
|-------------------|-----------------------|
| 1. Shield | 3. 4-3/4 in. (121 mm) |
| 2. Front crossbar | 4. Shield fasteners |

2. For normal cutting conditions, the height of the shield from the crossbar should be 4-3/4 in. (121 mm). Loosen the capscrews and nuts securing the shield to each side plate, adjust the shield to the correct height, and tighten the fasteners (Fig. 8).
3. Repeat the adjustment on the remaining cutting units and adjust the top bar; refer to Adjusting the Top Bar, page 6.

Note: The shield can be lowered in dry grass conditions (the clippings fly over the top of the baskets) or raised to allow for heavy, wet grass conditions (the clippings build up on the rear edge of the baskets).

Adjusting the Top Bar

Adjust the top bar to ensure the clippings are cleanly discharged from the reel area.

1. Loosen the screws securing the top bar (Fig. 9). Insert a 0.06 in. (1.5 mm) feeler gauge between the top of the reel and the bar and tighten the screws (Fig. 9). Ensure that the bar and reel are an equal distance apart across the entire reel.
2. Repeat the settings on the remaining cutting units.

Note: The bar is adjustable to compensate for changes in turf conditions. Adjust the bar closer to the reel when the turf is extremely wet and further away from the reel when the turf conditions are dry. The bar should be parallel to the

reel to ensure optimum performance and should be adjusted whenever the shield height is adjusted or whenever the reel is sharpened on a reel grinder.

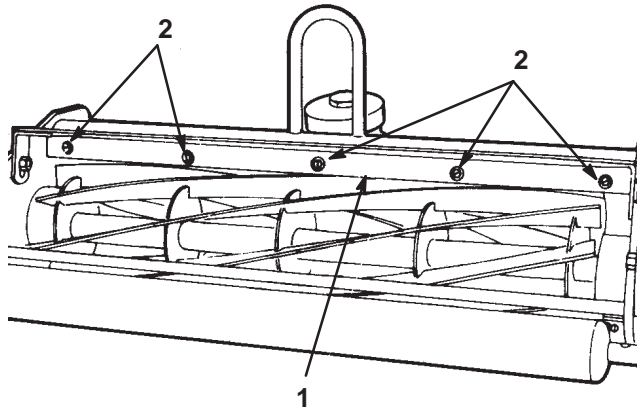

Figure 9

1. Top bar
2. Bar mounting screws

Operation

Prior to mowing each day, or as required, each cutting unit must be checked to verify proper bedknife-to-reel contact. **This must be performed even though the quality of cut is acceptable.**

1. Shut the engine off and lower the cutting units onto a hard surface.
2. Remove the grass baskets.
3. On each cutting unit, loosen the two flange nuts securing the reel motor to the cutting unit.
4. Twist the motor clockwise to disengage it from the cutting unit and remove the motor.
5. Slowly rotate the reel in the reverse direction and listen for reel-to-bedknife contact. If no contact is evident, turn the bedknife adjusting knob clockwise, one click at a time, until light contact is felt and heard.
6. If excessive contact is felt, turn the bedknife adjusting knob counterclockwise, one click at a time until no contact is evident. Then turn the bedknife adjusting knob one click at a time clockwise, until light contact is felt and heard.
7. Assemble the motor to the cutting unit.

Important Light contact is preferred at all times. If light contact is not maintained, the bedknife and reel edges will not sufficiently self-sharpen and dull cutting edges will result after a period of operation. If excessive contact is maintained, the bedknife and reel wear will be accelerated, which can lead to uneven wear and poor quality of cut.

Note: As the reel blades continue to run against the bedknife, a slight burr will appear on the front cutting edge surface along the full length of the bedknife. Improved cutting can be obtained if a file is occasionally run across the front edge of the bedbar to remove the burr.

Note: After extended operation, notches will eventually develop at both ends of the bedknife. These notches must be rounded off or filed flush with the cutting edge of the bedknife to ensure smooth operation.

Maintenance

Important To prevent damage to the hydraulic hoses, remove the reel motors before removing the cutting units.

Lubrication

There are seven grease fittings on each cutting unit (Fig. 10 and 11) that should be lubricated immediately after washing to purge water out of the bearings and increase bearing life. Lubricate them using a No. 2 multipurpose lithium-based grease. For best results, use a hand-operated grease gun.

1. Wipe each grease fitting with a clean rag.
2. Grease the reel bearings (Fig. 10) until grease comes out of the weep hole.

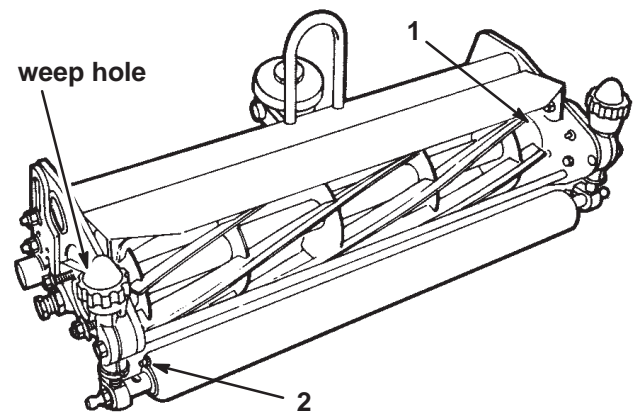

Figure 10

1. Grease reel bearing (both ends)
2. Grease front roller bearing (both ends)

3. Apply grease to the front and rear roller bearings (Fig. 10 and 11) until it begins to show around the seal lips.

Important Do not apply too much pressure or the grease seals will be permanently damaged.

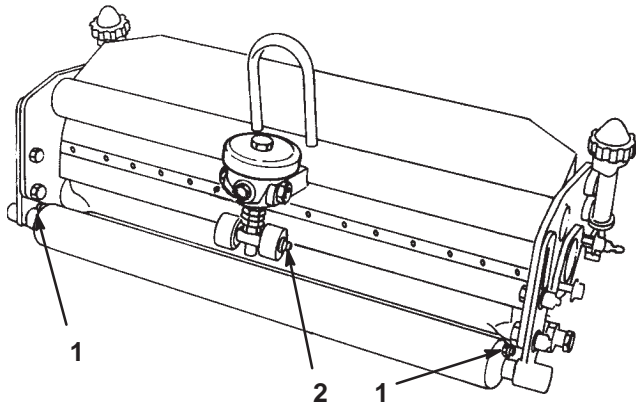

Figure 11

1. Grease rear roller bearing
2. Grease adjusting knob pivot point

4. Apply grease to the pivot points (Fig. 11).

5. Wipe excess grease away.

Reel Lapping

Connect a lapping machine to the cutting unit with an extension coupler and a 9/16 in. socket. The 9/16 in. socket can be positioned onto the capscrew on the reel shaft inside the counterbalance weight on the end of the cutting unit. Backlap according to the procedures in the Toro Sharpening Reel and Rotary Mowers Manual, Form No. 80-300PT.

Note: For a better cutting edge, run a file across the front face of the bedknife when the lapping operation is completed. This will remove any burrs or rough edges that may have built up on the cutting edge.



Caution



Contact with moving parts may cause personal injury.

Keep your body away from the reels during reel lapping.

Removing the Bedknife

Important To prevent damage to the hydraulic hoses, remove the reel motors before removing the cutting units.

1. Remove the spring arm retaining capscrew and washer from the pivot assembly. Loosen the pivot screws securing the bedknife pivot assembly to the reel frame supports (Fig. 12).

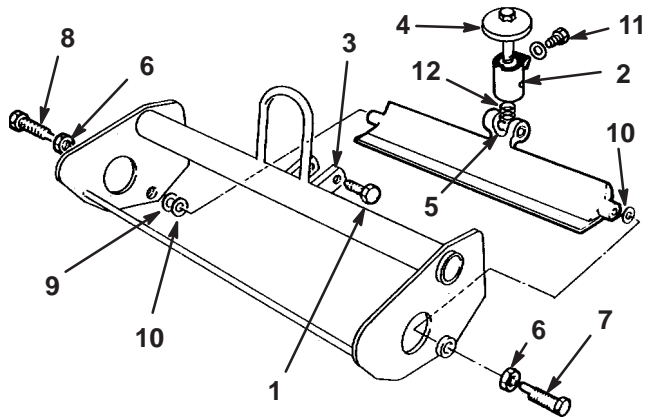

Figure 12

- | | |
|----------------------------|-----------------------------------|
| 1. Pivot screw | 8. Right bedbar pivot bolt |
| 2. Bedknife pivot assembly | 9. Steel washer |
| 3. Reel frame supports | 10. Plastic washer |
| 4. Adjustment knob | 11. Spring arm retaining capscrew |
| 5. Bedbar pivot | 12. Compression spring |
| 6. Jam nuts | |
| 7. Left bedbar pivot bolt | |

2. Rotate the adjustment knob and pivot assembly clockwise (left-hand thread) until it is unthreaded from the bedbar pivot (Fig. 12).

3. Loosen the jam nuts retaining the right and left bedbar pivot bolts. Remove the pivot bolts (Fig. 12).

Important For future installation, note the position of the plastic washer and steel washer on the right end of the bedbar, and the plastic washer on the left end of the bedbar.

4. Slide the bedbar down and out from under the cutting unit. Do not misplace the washers.

5. Adjust the reel bearings, then grind the reel to remove any taper and renew the cutting edges.

Note: For proper grinding of the bedknife, grind it in accordance with the procedures in the Toro Sharpening Reel and Rotary Mowers Manual, Form No. 80-300PT.

- On either end of the front side of the reel, insert a long strip of newspaper between the reel and bedknife. While slowly rotating the reel forward, turn the bedknife adjusting knob (Fig. 15) clockwise, one click at a time, until the paper is pinched lightly, which results in a slight drag when paper is pulled.
- Check for light contact at the other end of the reel by using paper. If light contact is not evident at both ends, the bedknife is not parallel to the reel: proceed to step 4.
- Loosen the jam nut on the left-hand bedbar pivot bolt enough to ease in turning the bolt.

The left-hand pivot bolt has an offset thread which, when rotated, acts as a cam to raise or lower the bedbar. On the bolt head there is an identification dot which denotes the offset of the bolt. When the dot is in the up position (Fig. 16) the left end of the bedbar is raised. As the bolt is turned clockwise and the dot is lowered, so is the left end of the bedbar. The identification dot needs to be positioned within the rear (180°) position when adjusting.

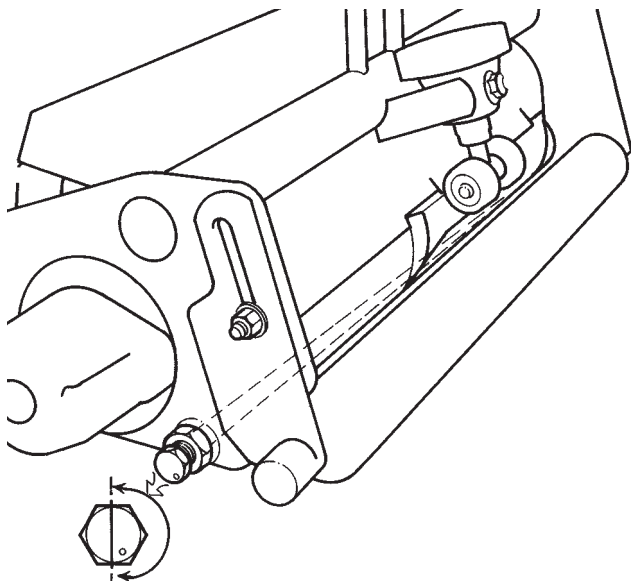

Figure 16

- Rotate the pivot bolt to raise or lower the bedbar as required.
- Check the adjustments by repeating steps 2 and 3.
- When light contact on the paper is evident at each end of the bedknife, tighten the left-hand jam nut while holding the pivot bolt in position. Ensure the pivot bolt did not become misadjusted when turning the jam nut. Adjust as required.

Preparing the Reel for Grinding

Important To prevent damage to the hydraulic hoses, remove the reel motors before removing the cutting unit.

Important Some reel grinders may require that the rear roller assembly be mounted to the cutting unit for proper support in the reel grinder.

The front roller may have to be removed so that the reel can be sharpened. To accomplish this, proceed as follows:

- Loosen the locknuts securing the height-of-cut adjusting rods at both ends of the cutting unit and the roller shaft clamp bolts (Fig. 17).

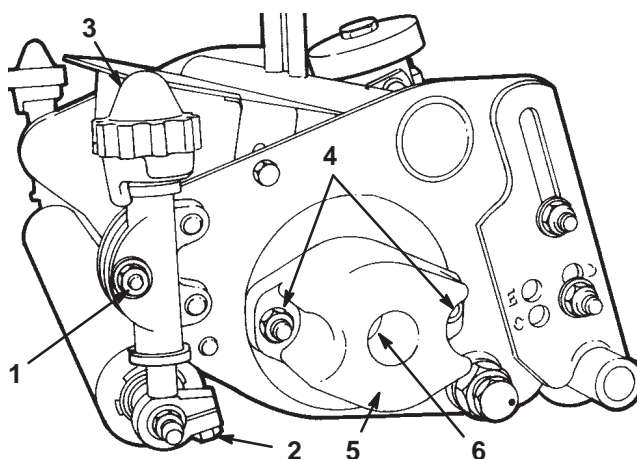

Figure 17

- Height-of-cut locknut
 - Roller shaft clamp bolt
 - Height-of-cut knob
 - End cap mounting nuts
 - Counterbalance end cap
 - Reel bearing adjustment nut
- Turn the height-of-cut adjustment knobs until they are disconnected from the height-of-cut adjusting rods (Fig. 17). The knobs are captivated on the upper washer face of the height-of-cut clamp.
 - Remove the roller assembly from the cutting unit by pulling evenly on both sides.
 - For proper grinding of the reel, grind in accordance with the procedures in the Toro Sharpening Reel and Rotary Mowers Manual, Form No. 80-300PT.

Important After the grinding operation is complete, assemble the cutting unit, check the bearing adjustment, and adjust the top shield and bar; refer to Adjusting the Shield Height, page 6, and Adjusting the Top Bar, page 6. Backlap the cutting unit to complete the sharpening operation.

Servicing and Adjusting the Reel Bearings

Important To prevent damage to the hydraulic hoses, remove the reel motors before removing the cutting unit.

Periodically check the drag on the reel bearings. They can be checked and adjusted in the following manner:

1. Turn the bedknife adjustment knob counterclockwise to ensure that there is no reel contact.
2. The reel bearing drag should be from 5 to 9 in.-lb. (1 N·m) (Fig. 17). This can be measured with a torque wrench.

If the bearing drag does not meet the above specification, the procedure to adjust the reel bearing drag is as follows:

- A. Remove the mounting nuts from the counterbalance end cap and remove the end cap from the mounting studs (Fig. 17).
- B. Remove the bolt mounted on the end of the reel shaft. This will make it possible for a large socket wrench to be mounted on the reel bearing adjusting nut inside the side plate.
- C. With the wrench mounted, hold the reel and tighten the large reel bearing adjustment nut (Fig. 17). Tighten it until the drag on the reel meets the 5 to 9 in.-lb. (1 N·m) specification.
- D. Install the bolt into the end of the reel shaft and check the torque with an inch/pound torque wrench.

Removing the Reel Assembly

Important To prevent damage to the hydraulic hoses, remove the reel motors before removing the cutting unit.

1. Remove the counterbalance end cap (Fig. 17).
2. Remove the large bearing adjustment nut from one end of the reel shaft (Fig. 17) and the special spline nut at the opposite end of the reel shaft.
3. Remove the mounting bolts from the bearing housing at both ends of the cutting unit (Fig. 18).

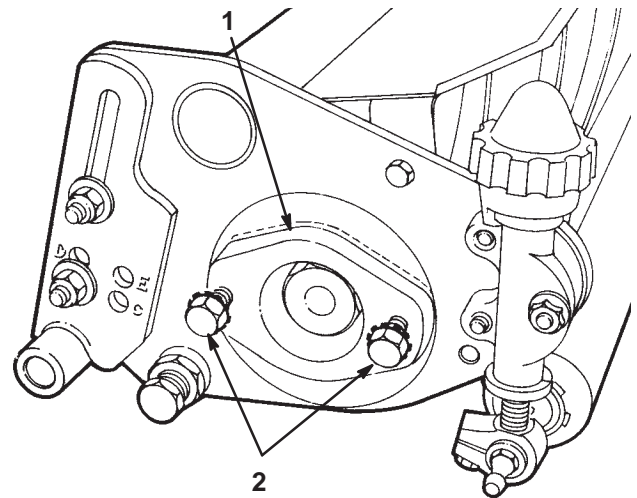

Figure 18

1. Bearing housing
2. Bearing housing mounting bolt

Important Remove the grease fittings from the bearing housing at each end of the cutting unit.

4. Using a plastic headed hammer, rotate the bearing housing slightly, install the bearing housing bolts from the outside housing, turn the bolts alternately against the side plate, and remove the bearing housing.
5. The bearing housing will slip out of the side plates and the reel assembly can be removed as soon as the bearing housings are disassembled from the side plates.



The Toro General Commercial Products Warranty

A Two-Year Limited Warranty

Conditions and Products Covered

The Toro Company and its affiliate, Toro Warranty Company, pursuant to an agreement between them, jointly warrant your 1996 or newer Toro Commercial Product ("Product") purchased after January 1, 1997, to be free from defects in materials or workmanship for two years or 1500 operational hours*, whichever occurs first. Where a warrantable condition exists, we will repair the Product at no cost to you including diagnosis, labor, parts, and transportation. This warranty begins on the date the Product is delivered to the original retail purchaser.

* Product equipped with hour meter

Instructions for Obtaining Warranty Service

You are responsible for notifying the Commercial Products Distributor or Authorized Commercial Products Dealer from whom you purchased the Product as soon as you believe a warrantable condition exists.

If you need help locating a Commercial Products Distributor or Authorized Dealer, or if you have questions regarding your warranty rights or responsibilities, you may contact us at:

Toro Commercial Products Service Department
Toro Warranty Company
8111 Lyndale Avenue South
Bloomington, MN 55420-1196
952-888-8801 or 800-982-2740
E-mail: commercial.service@toro.com

Owner Responsibilities

As the Product owner, you are responsible for required maintenance and adjustments stated in your operator's manual. Failure to perform required maintenance and adjustments can be grounds for disallowing a warranty claim.

Items and Conditions Not Covered

Not all product failures or malfunctions that occur during the warranty period are defects in materials or workmanship. This express warranty does not cover the following:

- Product failures which result from the use of non-Toro replacement parts, or from installation and use of add-on, modified, or unapproved accessories
- Product failures which result from failure to perform required maintenance and/or adjustments
- Product failures which result from operating the Product in an abusive, negligent or reckless manner
- Parts subject to consumption through use unless found to be defective. Examples of parts which are consumed, or used up, during normal Product operation include, but are not limited to, blades, reels, bedknives, tines, spark plugs, castor wheels, tires, filters, belts, etc.

Countries Other than the United States or Canada

Customers who have purchased Toro products exported from the United States or Canada should contact their Toro Distributor (Dealer) to obtain guarantee policies for your country, province, or state. If for any reason you are dissatisfied with your Distributor's service or have difficulty obtaining guarantee information, contact the Toro importer. If all other remedies fail, you may contact us at Toro Warranty Company.

- Failures caused by outside influence. Items considered to be outside influence include, but are not limited to, weather, storage practices, contamination, use of unapproved coolants, lubricants, additives, or chemicals, etc.
- Normal "wear and tear" items. Normal "wear and tear" includes, but is not limited to, damage to seats due to wear or abrasion, worn painted surfaces, scratched decals or windows, etc.

Parts

Parts scheduled for replacement as required maintenance are warranted for the period of time up to the scheduled replacement time for that part.

Parts replaced under this warranty become the property of Toro. Toro will make the final decision whether to repair any existing part or assembly or replace it. Toro may use factory remanufactured parts rather than new parts for some warranty repairs.

General Conditions

Repair by an Authorized Toro Distributor or Dealer is your sole remedy under this warranty.

Neither The Toro Company nor Toro Warranty Company is liable for indirect, incidental or consequential damages in connection with the use of the Toro Products covered by this warranty, including any cost or expense of providing substitute equipment or service during reasonable periods of malfunction or non-use pending completion of repairs under this warranty. Except for the Emissions warranty referenced below, if applicable, there is no other express warranty. All implied warranties of merchantability and fitness for use are limited to the duration of this express warranty.

Some states do not allow exclusions of incidental or consequential damages, or limitations on how long an implied warranty lasts, so the above exclusions and limitations may not apply to you.

This warranty gives you specific legal rights, and you may also have other rights which vary from state to state.

Note regarding engine warranty: The Emissions Control System on your Product may be covered by a separate warranty meeting requirements established by the U.S. Environmental Protection Agency (EPA) and/or the California Air Resources Board (CARB). The hour limitations set forth above do not apply to the Emissions Control System Warranty. Refer to the Engine Emission Control Warranty Statement printed in your operator's manual or contained in the engine manufacturer's documentation for details.