



# Workman<sup>®</sup> 2110

## Utility Vehicle

Model No. 07277TC—220000001 and Up

## Parts Catalog

---

### Ordering Replacement Parts

To order replacement parts, please supply: the part number, the quantity, and the description of each part desired.

### Understanding Reference Numbers

Each identified part in an illustration has a reference number. The reference number for a part also appears in the parts list, along with other information about the part.

This catalog uses two special reference number formats, one to indicate parts in a service assembly and another to indicate the quantity of a given part in an illustration.

### Service Assembly Reference Numbers

Parts in service assemblies have reference numbers in the form **a:b**. The **a** represents the reference number of the entire service assembly and the **b** represents a sequential number unique to each part within the service assembly.

For example, a wheel assembly might be identified by reference number **6**, the tire by **6:1**, the valve by **6:2**, and the wheel by **6:3**. When you order the assembly identified by reference number **6**, you receive all parts identified by reference numbers **6:1**, **6:2**, and **6:3**. However, you may also order any part individually.

Reference numbers of this type appear in illustrations and in part lists.

### Reference Numbers Indicating Quantity

In an illustration, if a reference number indicates more than one part, the reference number has the form **nX y**. The **n** represents the quantity of the part, the **X** is the multiplication symbol, and the **y** represents the reference number.

For example, in an illustration, the reference number **2X 37** means that two of the parts identified by reference number **37** are indicated.

## Contents

Description	Page	Description	Page
Hood and Fender Assembly .....	3	Box and Tailgate Installation Assembly .....	23
Pedal Assembly .....	4	Box and Tailgate Assembly .....	24
Shifter Assembly .....	5	Brake and Master Cylinder Assembly .....	25
Frame Assembly .....	6	Left Hand Caliper Assembly No. 104-6801 ...	26
Seatbase Assembly .....	7	Right Hand Caliper Assembly No. 104-6802 ..	27
Front Tire and Steering Assembly .....	8	Master Cylinder Assembly No. 104-6782 .....	28
Engine and Clutch Assembly .....	9	Electrical Schematic .....	29
Drive Clutch Assembly No. 99-7145 .....	11	Cylinder Assembly .....	30
Starter Generator Assembly No. 99-7108 .....	12	Crankcase Assembly .....	31
Rear Tire and Transaxle Assembly .....	13	Crankshaft Assembly .....	32
Drive Clutch Assembly No. 99-7104 .....	14	Cylinder Head Assembly .....	33
Transaxle Assembly No. 104-6898 .....	15	Oil Filter, Tube and Pump Assembly .....	34
Transaxle Assembly No. 104-6898 .....	16	Carburetor Assembly .....	35
Left Hand Brake Assembly No. 104-6807 ....	17	Intake Manifold Assembly .....	36
Right Hand Brake Assembly No. 104-6806 ...	18	Flywheel Assembly .....	37
Drivetrain Mount Assembly .....	19	Blower Housing Assembly .....	38
Air Filter Assembly No. 99-7120 .....	20	Gasket Assembly .....	39
Upper Steering Assembly .....	21	Carburetor Overhaul Kit Assembly .....	40
Steering Gearbox Assembly No. 99-7660 ....	22		

## Part Description Abbreviations

Part descriptions in this catalog may include the following abbreviations.

Abbreviation	Meaning	Abbreviation	Meaning
AR .....	as required	HYD .....	hydraulic
ASM .....	assembly	INC .....	incorporated
CARR .....	carriage	LH .....	left hand
DEG .....	degrees	NI .....	nylon insert
FH .....	flat head	PPH .....	Phillips pan head
GA .....	gauge	PTH .....	Phillips truss head
HF .....	hex flange	PTO .....	power take off
HH .....	hex head	RH .....	right hand
HHF .....	hex head flange	SFH .....	slotted fillister head
HLH .....	hex lag head	SHH .....	slotted hex head
HJ .....	hex jam	SQH .....	square head
HOC .....	height-of-cut	SHWH .....	slotted hex washer head
HS .....	hex socket	SPH .....	slotted pan head
HSBH .....	hex socket button head	SRH .....	slotted round head
HSFH .....	hex socket flat head	STD .....	standard
HSH .....	hex socket head	TAP .....	self tapping
HWH .....	hex washer head	TTH .....	Torx truss head
HWHTF .....	hex washer head thread forming	WH .....	wing head

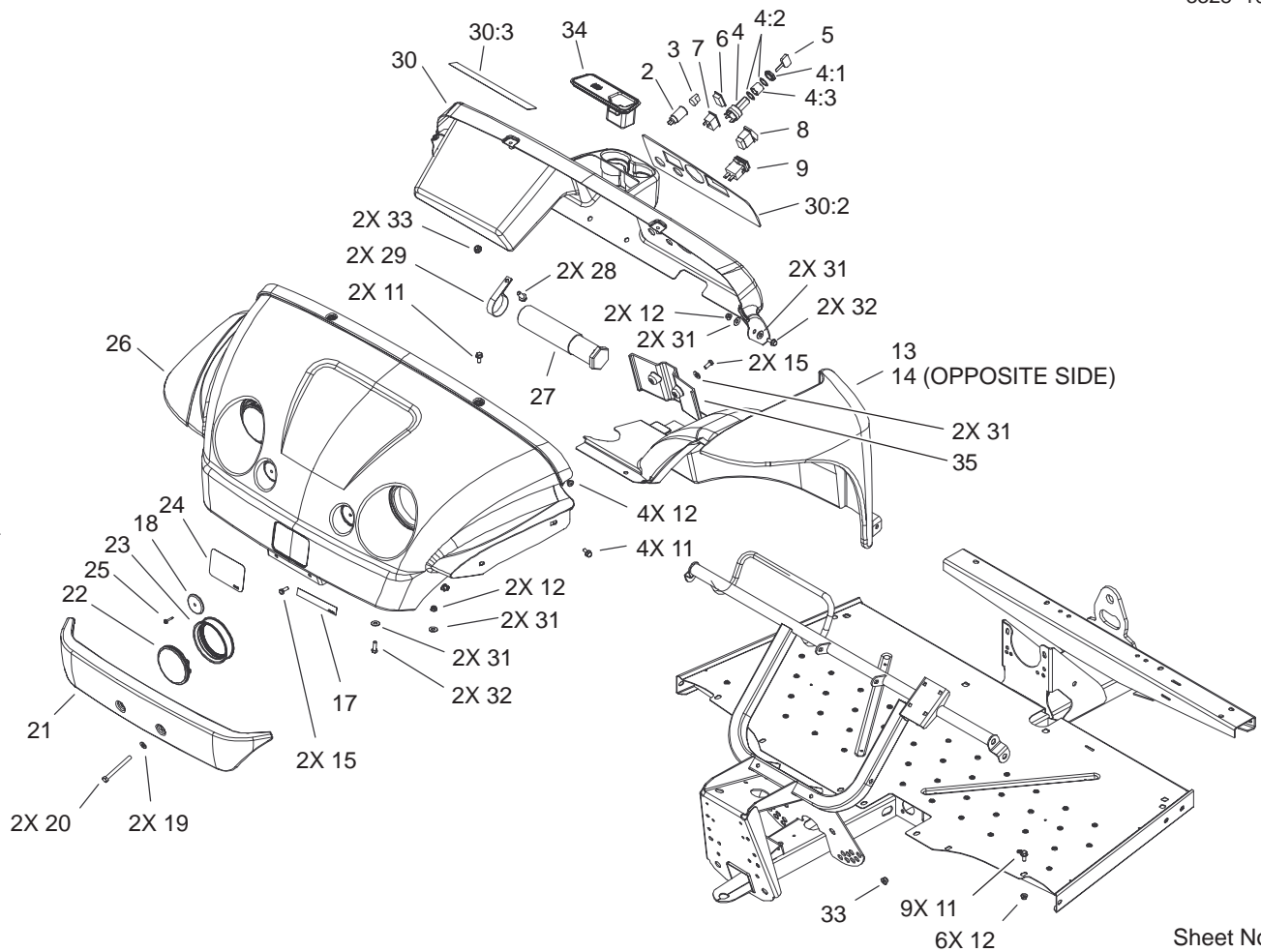

Sheet No.:2

## Hood and Fender Assembly

Ref. No.	Part No.	Qty.	Description
2	99-7411	1	Point-Power
3	99-7416	1	Cap
4	104-6929	1	Switch-Ignition
4:1	104-7042	1	Nut-Switch, Plastic
4:2	104-7019	2	Washer-Lock, Internal
4:3	104-7021	1	Spacer-Switch
5	99-7418	2	Key-Ignition
6	99-7420	1	Plug-Hole
7	99-7410	1	Light-Oil
8	95-8999	1	Switch
9	94-4208	1	Hourmeter
11	3234-5	14	Screw
12	104-8300	14	Nut-Flange, NI
13	104-7076	1	LH Fender ASM
14	104-7077	1	RH Fender ASM
15	32104-32	4	Screw-HH
17	104-7074	1	Decal-Workman 2110
18	99-7312	2	Reflector
19	3256-24	2	Washer-Flat
20	323-42	2	Screw-HH
21	99-7733	1	Bumper-Plastic
22	99-7310	2	Headlight
23	99-7311	2	Mount-Headlight
24	99-7339	1	Decal-Logo, Toro
25	32144-89	2	Screw-Forming, Thread

Ref. No.	Part No.	Qty.	Description
26	104-7003	1	Hood
27	74-0720	1	Tube-Manual
28	3234-11	2	Screw-HHF
29	2412-133	2	R-Clamp
30	104-6849	1	Dash ASM
30:2	99-7343	1	Decal-Warning, Dash
30:3	104-6581	1	Decal-Danger
31	3256-3	10	Washer-Flat
32	3234-17	4	Screw-HHF
33	104-8301	4	Nut-Flange, NI
34	104-6930	1	Plug-Rubber
35	104-7075	1	Cover-Channel





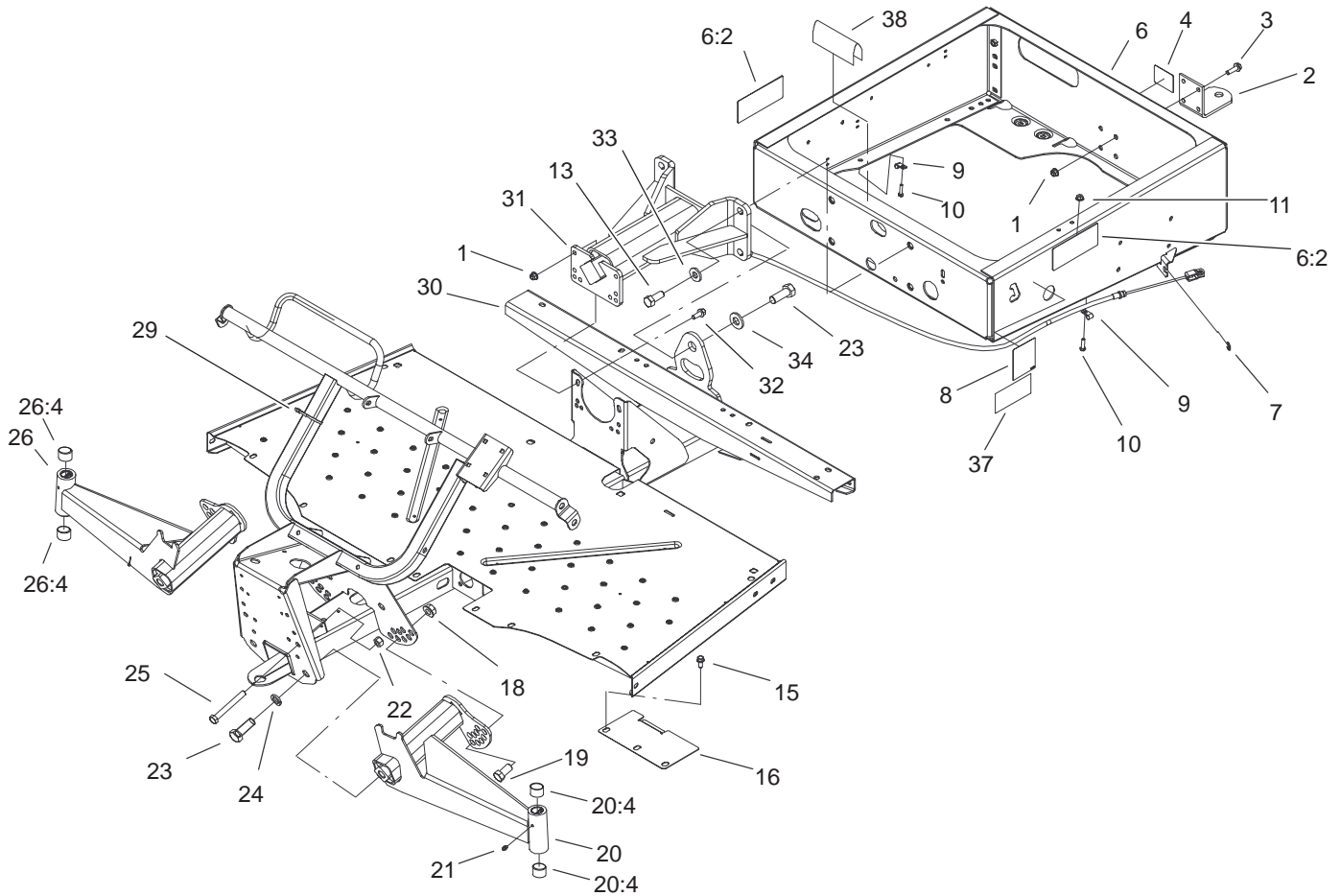

Sheet No.:5

## Frame Assembly

Ref. No.	Part No.	Qty.	Description
1	104-8301	8	Nut-Flange, NI
2	99-7654-03	1	Hitch-Duty, Light
3	3234-24	4	Screw-HHF
4	99-7350	1	Decal-Information
6	99-7362	1	Rear Frame ASM
6:2	99-7345	2	Decal-Warning
7	32120-47	2	Ring-Retaining, External
8	99-7349	1	Decal-Information, Boxlatch
9	2412-89	2	Clamp
10	321-6	2	Screw-HH
11	32128-33	2	Nut-HF
13	327-4	4	Screw-HH
15	3234-5	2	Screw
16	104-6781-03	1	Cover-Pedal
18	32128-54	2	Nut-Flange
19	3214-2	2	Screw-HH
20	99-7685	1	LH A-Arm ASM
20:4	3-0348	2	Bushing
21	302-5	2	Fitting-Grease
22	3296-23	2	Nut-Lock, NI
23	328-24	5	Screw-HH
24	3254-7	4	Washer-Lock/Int
25	325-17	2	Screw-HH
26	99-7684	1	RH A-Arm ASM

Ref. No.	Part No.	Qty.	Description
26:4	3-0348	2	Bushing
29	3290-379	11	Tie-Cable
30	99-7463-03	1	Frame-Front
31	99-7700	1	Pivot Yoke ASM
32	3234-11	4	Screw-HHF
33	99-7667	4	Washer-Flat
34	87-3060	1	Washer-Hardened
37	104-6591	1	Decal-Capacity
38	95-5686	1	Trim

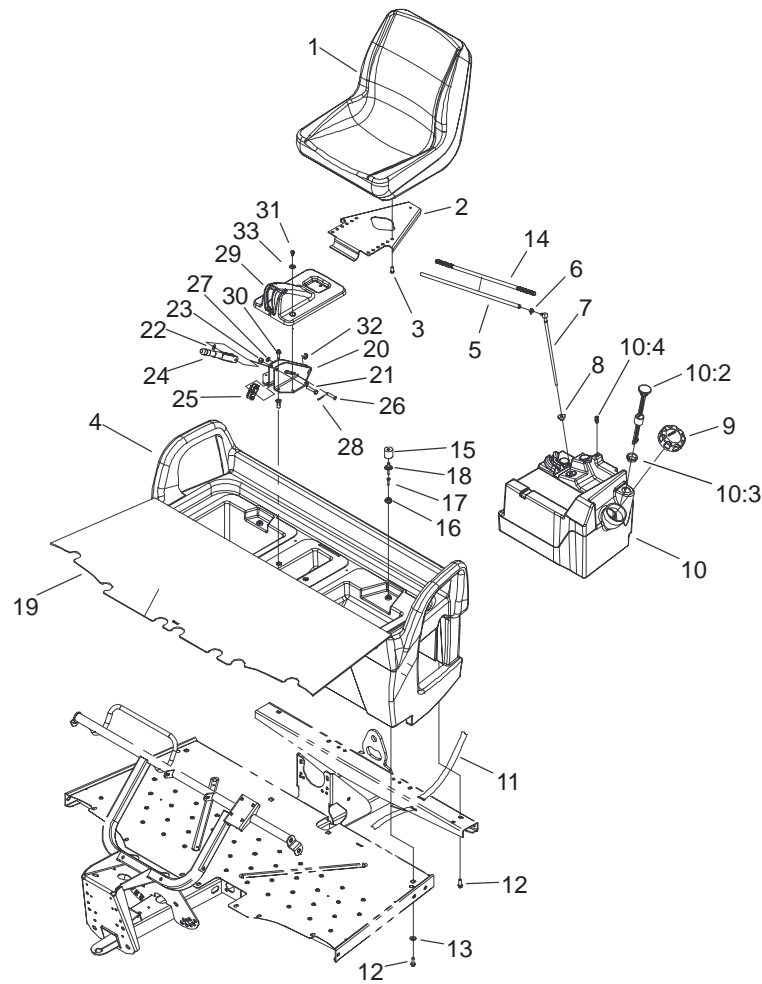

Sheet No.:6

## Seatbase Assembly

Ref. No.	Part No.	Qty.	Description	Ref. No.	Part No.	Qty.	Description
1	99-7281	2	Seat	22	3290-477	1	Washer-Curved
2	99-7829	2	Bracket-Seat	23	3296-39	1	Nut-Lock, NI
3	33114-016	8	Screw-HH	24	104-6842	1	Lever-Brake, Park
4	104-6847	1	Seat Base ASM	25	87-3480	1	Bracket-Equalizer, Cable
5	99-7187	1	Hose-Fuel	26	94-3829	1	Pin-Clevis
6	2412-98	1	Clamp	27	3256-23	1	Washer-Flat
7	99-7264	1	Pipe-Stand	28	3272-6	1	Pin-Cotter
8	46-6560	1	Bushing	29	104-7014	1	Cover-Brake, Parking
9	95-4192	1	Unleaded Gas Cap ASM	30	3234-17	4	Screw-HHF
10	99-7323	1	Fuel Tank ASM	31	12-3270	2	Screw
10:2	99-7262	1	Gauge-Fuel	32	32120-47	2	Ring-Retaining, External
10:3	95-8972	1	Grommet	33	3256-1	2	Washer-Flat
10:4	99-7267	1	Vent-Air				
11	3339-175	1	Strapping-Web, 48"				
12	3234-17	8	Screw-HHF				
13	88-7200	4	Washer-Flat				
14	99-7129	1	Conduit-Line, Fuel				
15	99-7830	2	Rubber Receptical ASM				
16	99-7833	2	Post-Holding				
17	32108-5	2	Screw-FH				
18	3290-412	2	Rivet				
19	104-6590	1	Mat-Floor				
20	104-6844-03	1	Support-Brake, Park				
21	323-10	1	Screw-HH				

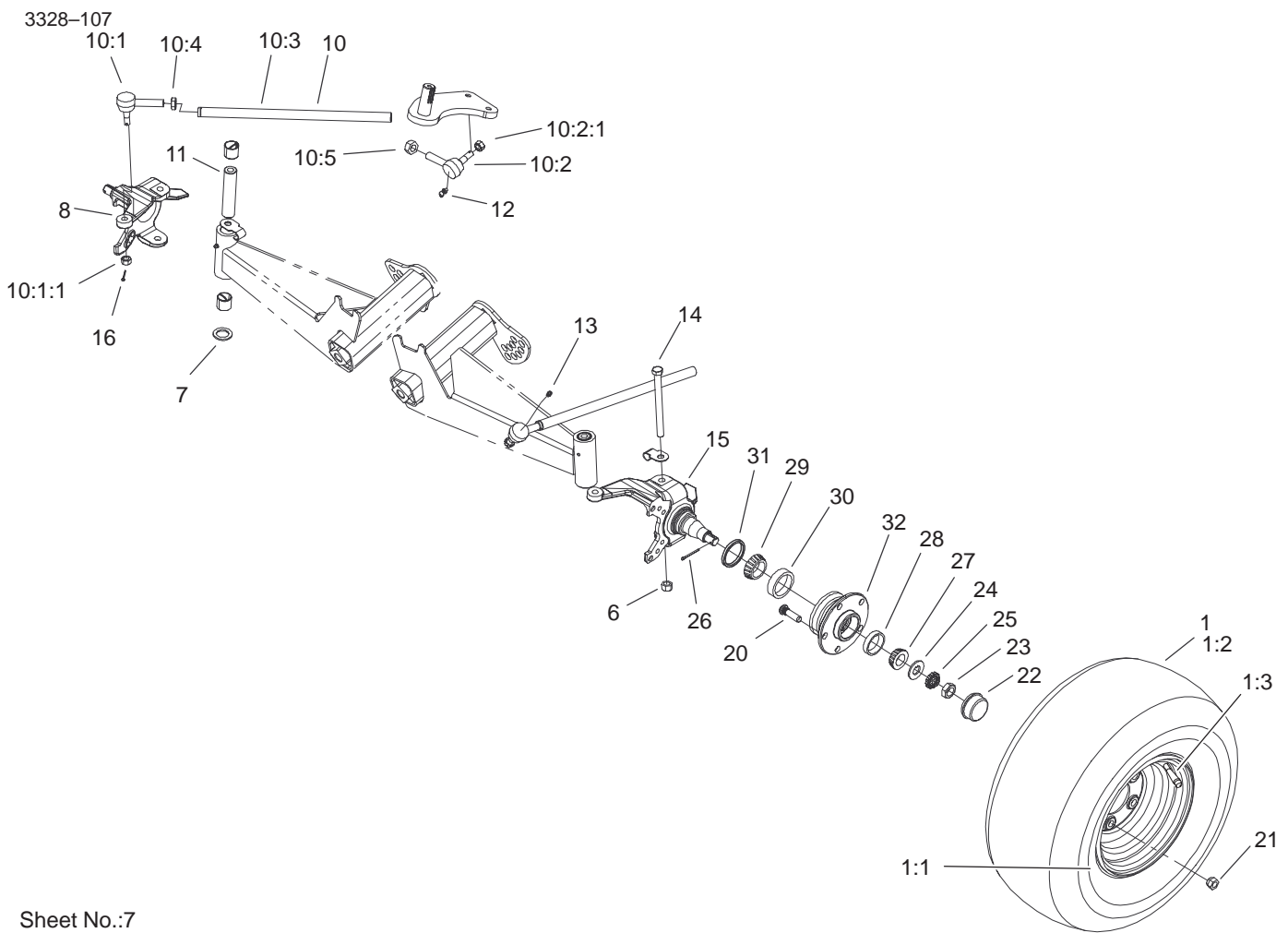

Sheet No.:7

## Front Tire and Steering Assembly

Ref. No.	Part No.	Qty.	Description
1	104-7085	2	Tire/Wheel ASM
1:1	104-7082	1	Wheel
1:2	104-7064	1	Tire
1:3	232-27	1	Stem-Valve
6	3296-23	2	Nut-Lock, NI
7	256-115	2	Washer-Thrust
8	104-6877-03	1	Spindle-Machined, RH Disc
☆10		2	Tie Rod ASM
10:1	112772	1	Joint-Ball, RH
10:1:1	915031	1	Nut
10:2	112771	1	Joint-Ball, LH
10:2:1	915031	1	Nut
10:3	99-7600-03	1	Rod-Tie
10:4	3220-11	1	Nut-Jam
10:5	3218-21	1	Nut-Jam
11	99-7499	2	Sleeve-Kingpin
12	302-60	2	Fitting-Grease
13	302-5	2	Fitting-Grease
14	325-20	2	Screw-HH
15	104-6876-03	1	Spindle-Disc, LH
16	3272-7	4	Pin-Cotter
20	10-6830	10	Stud-Type, Drive
21	242-50	10	Nut-Lug
22	241-119	2	Cap-Dust
23	3220-7	2	Nut-Jam

Ref. No.	Part No.	Qty.	Description
24	93-0309	2	Washer-Tab
25	93-0307	2	Nut-Lock, Retainer
26	3272-12	2	Pin-Cotter
27	254-94	2	Bearing-Cone, Taper
28	254-72	2	Bearing-Cup, Tapered
29	254-106	2	Cone-Bearing, Tapered
30	254-107	2	Cup-Bearing, Tapered
31	87-3590	2	Seal-Bearing
32	104-6809-03	2	Hub (Machined)

☆ Not serviced separately

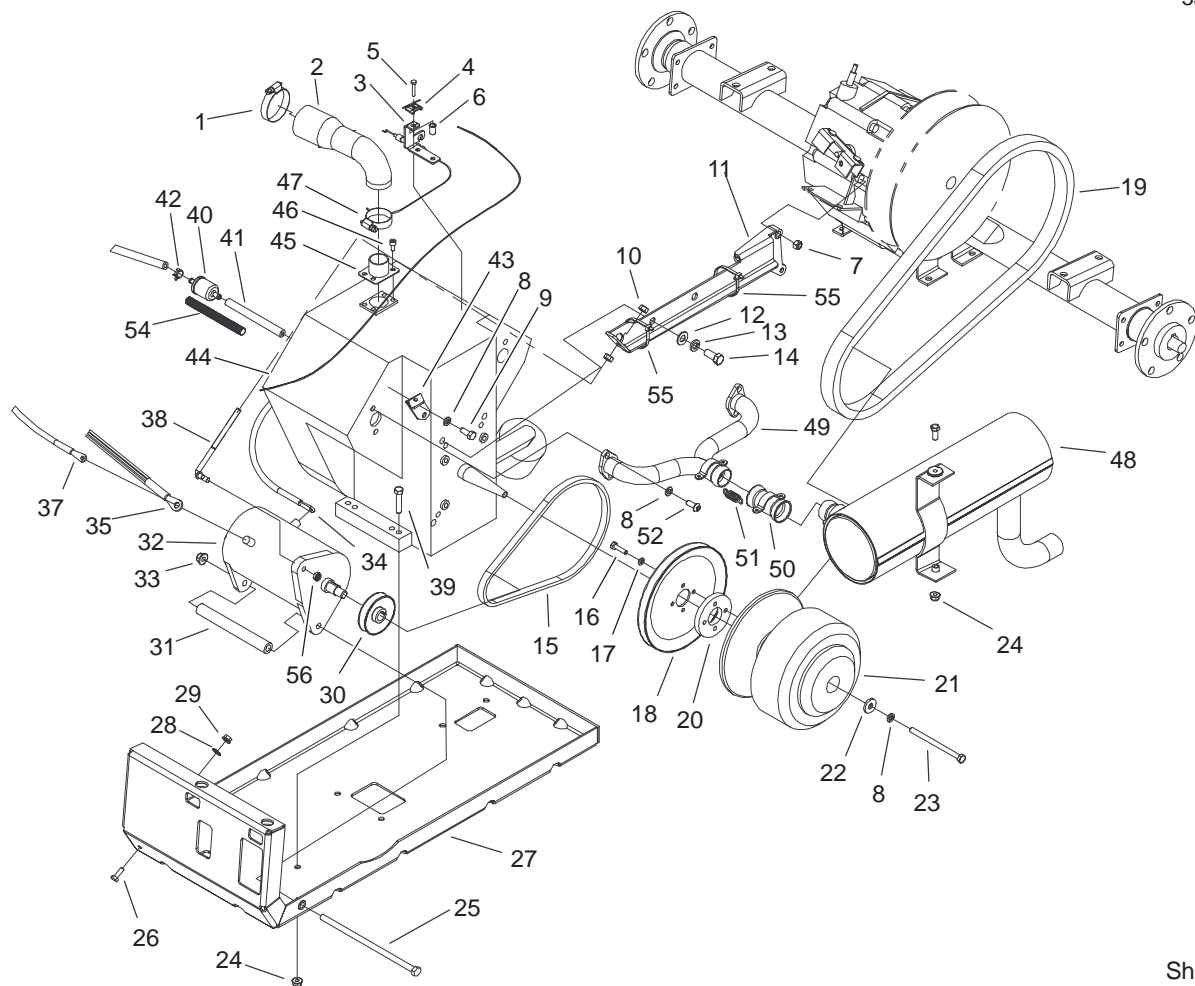

Sheet No.:8

## Engine and Clutch Assembly

Ref. No.	Part No.	Qty.	Description
1	2412-130	1	Clamp-Hose
2	99-7106	1	Hose-Intake
3	99-7097	1	Bracket-Cable
4	81-1690	1	Clamp-Cable
5	3290-432	1	Screw-HH
6	32148-14	1	Insert-Threaded
7	33024-00	2	Nut-Lock
8	3253-4	6	Washer-Lock
9	66-3160	2	Screw-Cap
10	3217-6	2	Nut-Hex
11	104-6631-03	1	Torque Arm ASM
12	3256-25	2	Washer-Flat
13	3253-6	2	Washer-Lock
14	324-4	2	Screw-HH
15	99-7133	1	V-Belt-Starter
16	321-6	4	Screw-HH
17	3253-3	4	Washer-Lock
18	99-7131	1	Pulley-Engine
19	99-7144	1	Belt-Drive
20	99-7064	1	Spacer-Starter
21	99-7145	1	Clutch-Drive
22	5-0838	1	Washer
23	99-7201	1	Screw-HH
24	104-8300	5	Nut-Flange, NI
25	99-7203	1	Screw
26	321-4	1	Screw-HH

Ref. No.	Part No.	Qty.	Description
27	104-6433-03	1	Mount-Engine
28	3255-8	1	Washer-Lock/Ext
29	32128-32	1	Nut-HHF
30	99-7130	1	Pulley-Starter
31	99-7053	1	Pivot-Starter
32	99-7108	1	Generator-Starter
33	104-8301	2	Nut-Flange, NI
34	99-7403	1	Cable-Negative
35	99-7437	1	Harness-Wire, Engine
37	104-6926	1	Cable-Positive
38	104-6629	1	Rod-Starter
39	322-8	4	Screw-HH
40	94-2690	1	Filter-Fuel
41	47-2966	1	Hose-Fuel
42	2412-98	3	Clamp
43	99-7119	1	Bracket-Tie, Cable
44	104-6466	1	Engine-16hp, Briggs & Stratton
45	99-7083	1	Bracket-Intake
46	99-7202	4	Screw
47	2412-3	1	Clamp-Hose
48	104-6475	1	Muffler-Engine
49	104-6476	1	Manifold-Engine
50	104-6477	1	Coupler-Exhaust
51	104-6478	4	Spring-Coupler, Exhaust



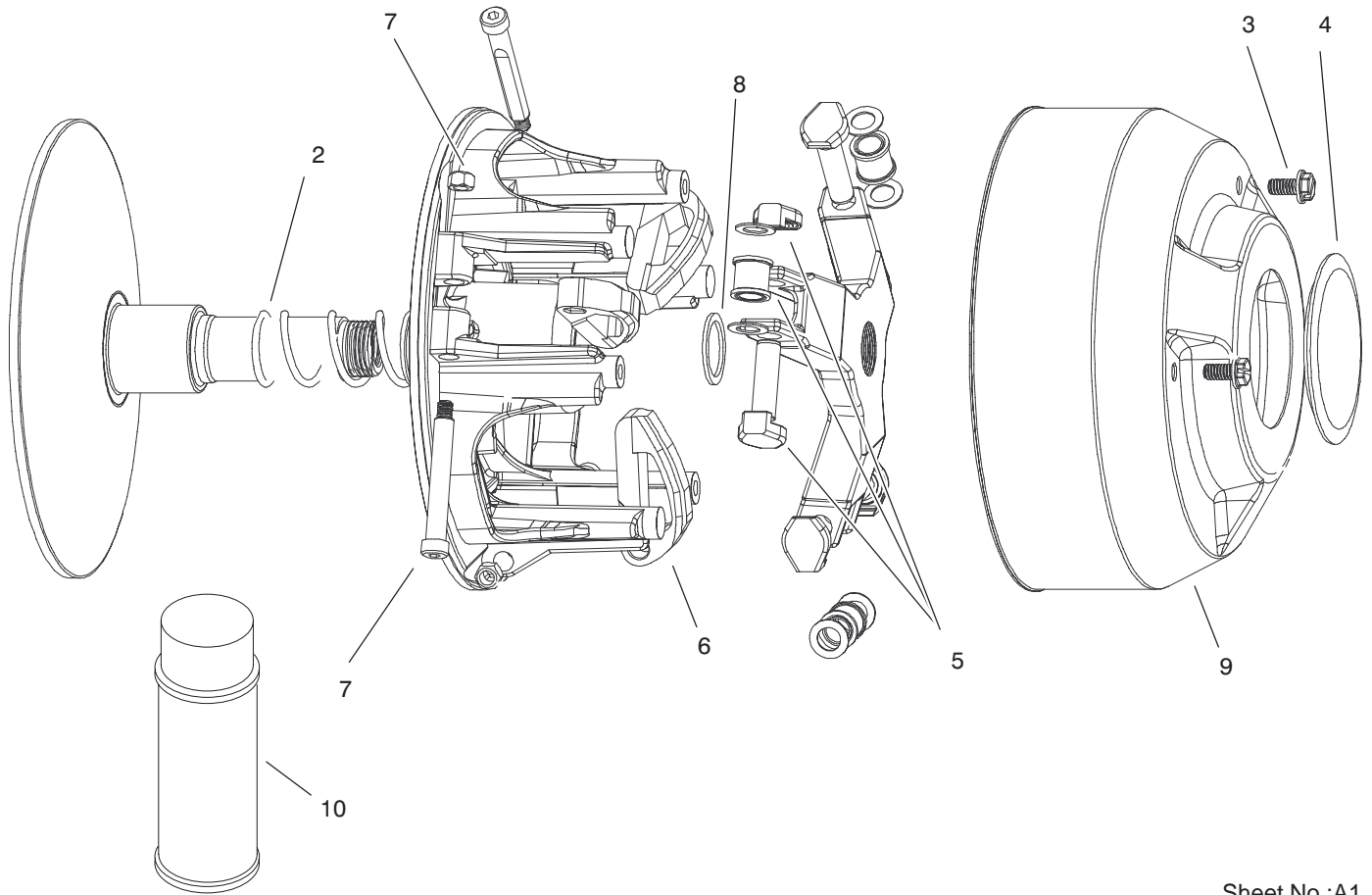

Sheet No.:A1  
T-3580

## Drive Clutch Assembly No. 99-7145

Ref. No.	Part No.	Qty.	Description
2	104-1686	1	Spring
3	3234-26	3	Screw
4	104-1690	1	Cap
5	104-1697	1	Spider Roller Kit
6	104-1696	1	Arm-Cam
7	104-4257	1	Button Kit
8	104-1687	1	Spacer
9	104-1691	1	Cover
10	104-7011	1	Lubricant-Dry

Ref. No.	Part No.	Qty.	Description

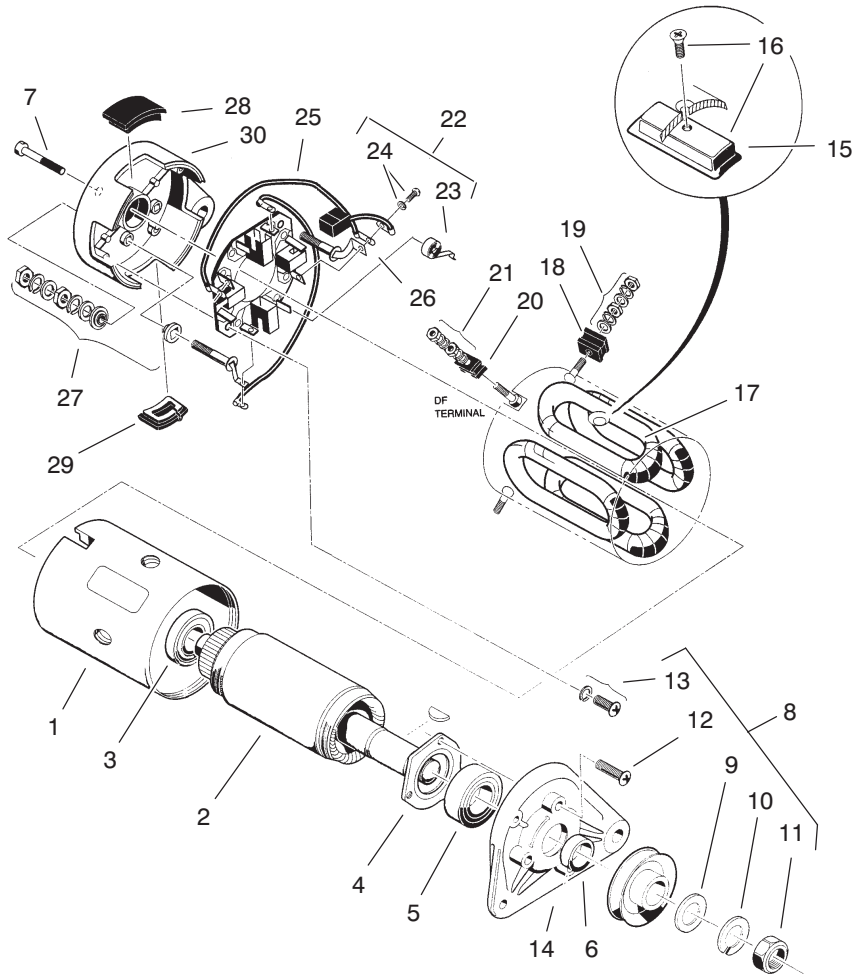

Sheet No.:A2  
T-3545

## Starter Generator Assembly No. 99-7108

Ref. No.	Part No.	Qty.	Description
☆1		1	Yoke
2	104-1210	1	Armature Kit
3	104-1211	1	Bearing-Ball, Rear
4	104-1212	1	Retainer
5	104-1213	1	Bearing-Ball, Front
6	104-1214	1	Spacer
7	104-1215	2	Bolt
☆8		1	Nut & Screw Set
9	104-1216	1	Washer-Plain
10	104-1217	1	Washer-Spring
11	104-1218	1	Nut-Hex
☆12		3	Screw-Flange
13	104-1219	2	Set-Screw
14	104-1220	1	Bracket-Front
☆15		4	Pole
16	104-1221	1	Set-Pole & Screw
17	104-1222	1	Field Stator Coil ASM
☆18		2	F Mold
19	104-1223	2	Set-Screw
☆20		1	Df Mold
21	104-1224	1	Set-Screw
22	104-1225	1	Brush Holder Kit
23	104-1226	4	Spring-Brush
24	104-1227	1	Brush & Screw Set
☆25		2	Brush Connector ASM
☆26		2	A Terminal ASM

Ref. No.	Part No.	Qty.	Description
27	104-1228	2	Screw & Mold ASM
☆28		1	Cover Set
☆29		1	Cover B
☆30		1	Bracket-Rear

☆ Not serviced separately

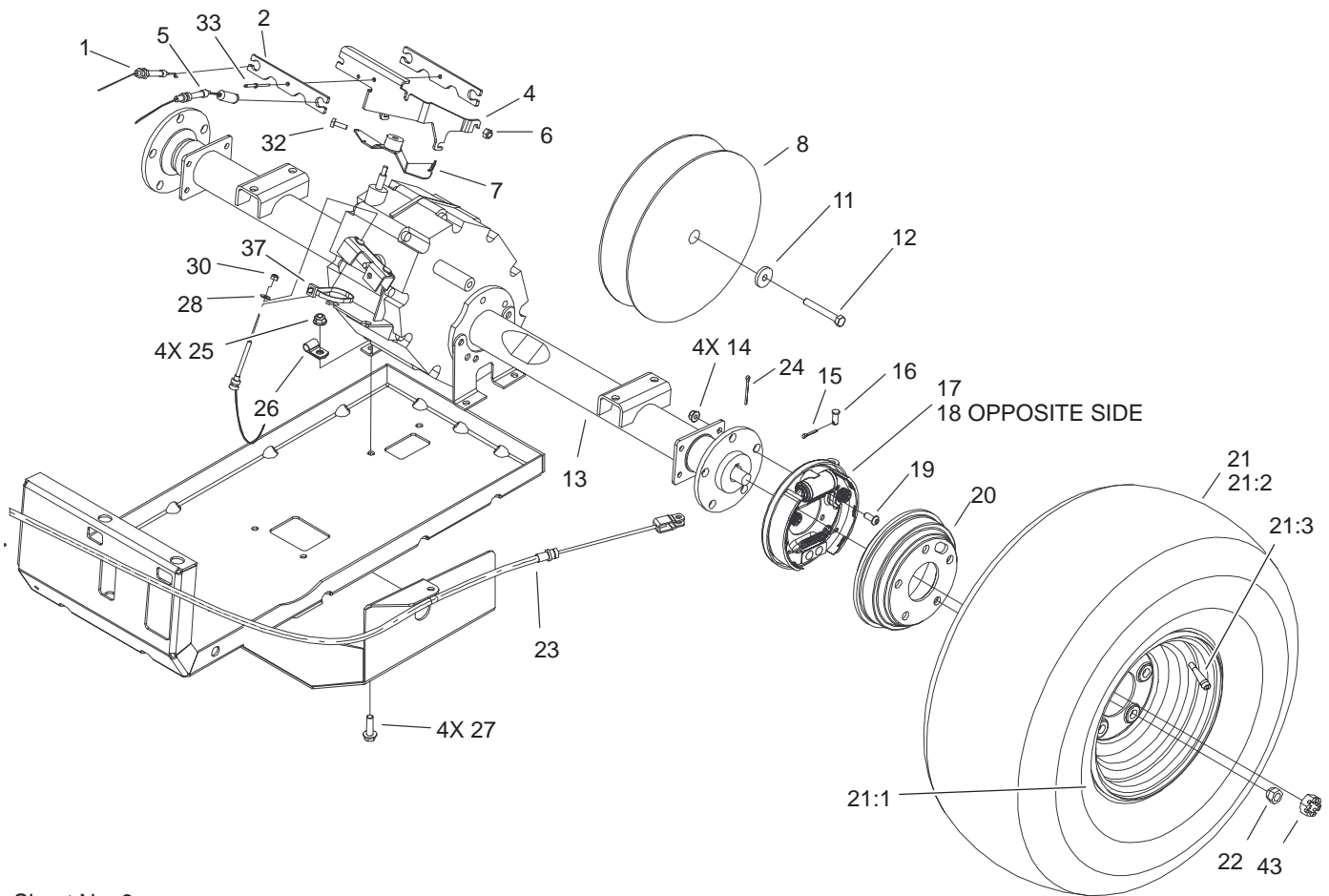

Sheet No.:9

## Rear Tire and Transaxle Assembly

Ref. No.	Part No.	Qty.	Description
1	104-6584	1	Cable-Governor
2	99-7121	2	Bracket-Tamper
4	99-7054	1	Bracket-Cables
5	104-6572	1	Cable-Throttle
6	33024-00	3	Nut-Lock
7	104-6569	1	Bracket-Governor
8	99-7104	1	Clutch-Driven
11	104-6563	1	Washer-Clutch
12	104-6564	1	Screw-HH
13	104-6898	1	Transaxle
14	104-8300	8	Nut-Flange, NI
15	3272-10	2	Pin-Cotter
16	283-62	2	Pin-Clevis
17	104-6807	1	LH Brake ASM
18	104-6806	1	RH Brake ASM
19	3274-55	8	Screw-HSBH
20	104-6500	2	Drum-Brake
21	104-7084	2	Tire/Wheel ASM
21:1	104-7083	1	Wheel
21:2	104-7063	1	Tire
21:3	232-27	1	Stem-Valve
22	242-50	10	Nut-Lug
23	104-6846	2	Cable-Brake, Park
24	3272-42	2	Pin-Cotter
25	104-8301	4	Nut-Flange, NI
26	2412-10	1	R-Clamp

Ref. No.	Part No.	Qty.	Description
27	3234-24	4	Screw-HHF
28	3256-49	2	Washer-Flat
30	3296-2	2	Nut-Lock
32	3241-6	2	Screw-SQH
33	99-7122	1	Rivet-Annodized
37	3290-378	1	Tie-Cable
43	104-1656	2	Nut-Castle

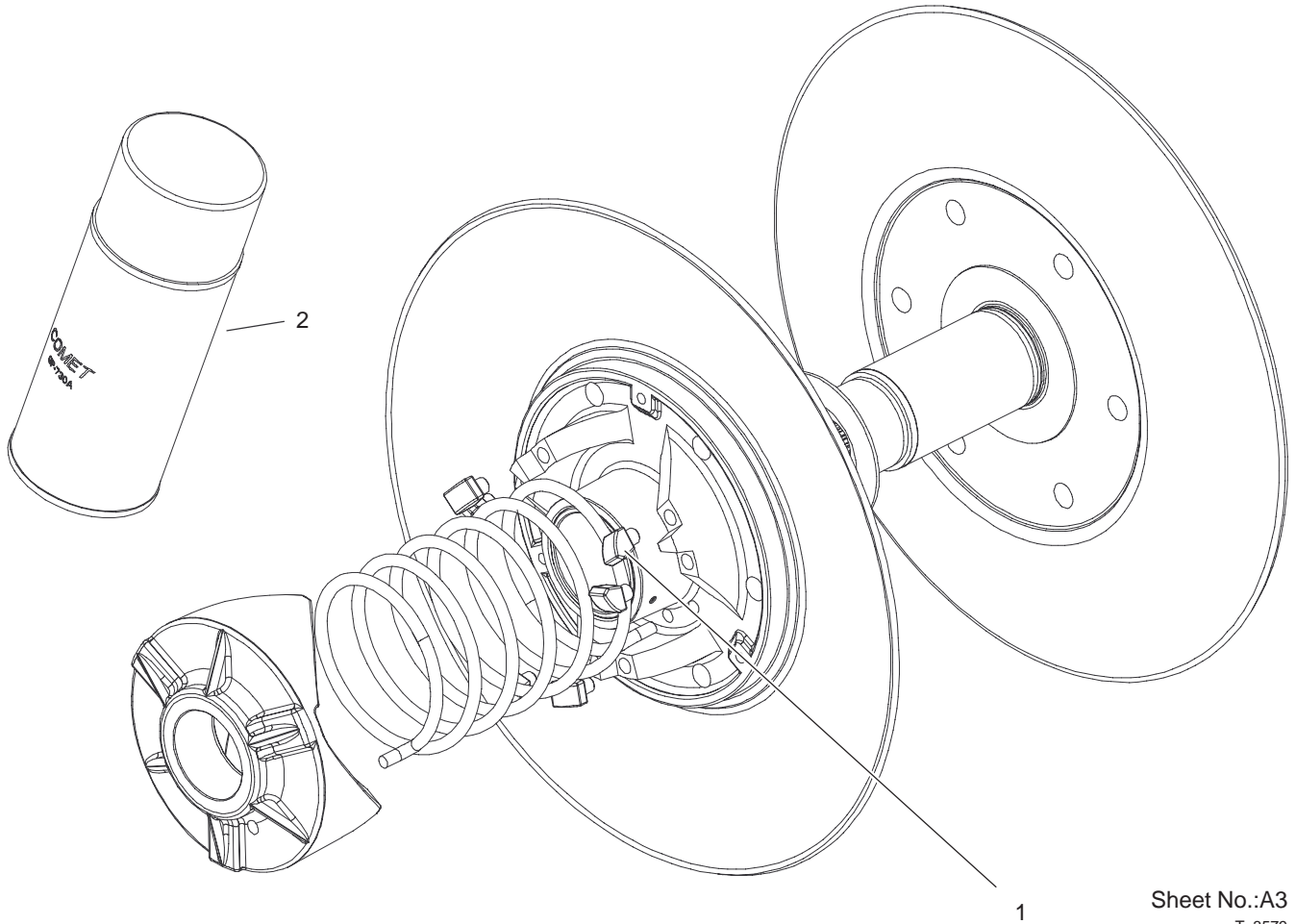

Sheet No.:A3  
T-3579

## Drive Clutch Assembly No. 99-7104

Ref. No.	Part No.	Qty.	Description
1	104-4256	6	Pivot Bolt And Nut Kit
2	104-7011	1	Lubricant-Dry

Ref. No.	Part No.	Qty.	Description

# Transaxle Assembly No. 104-6898

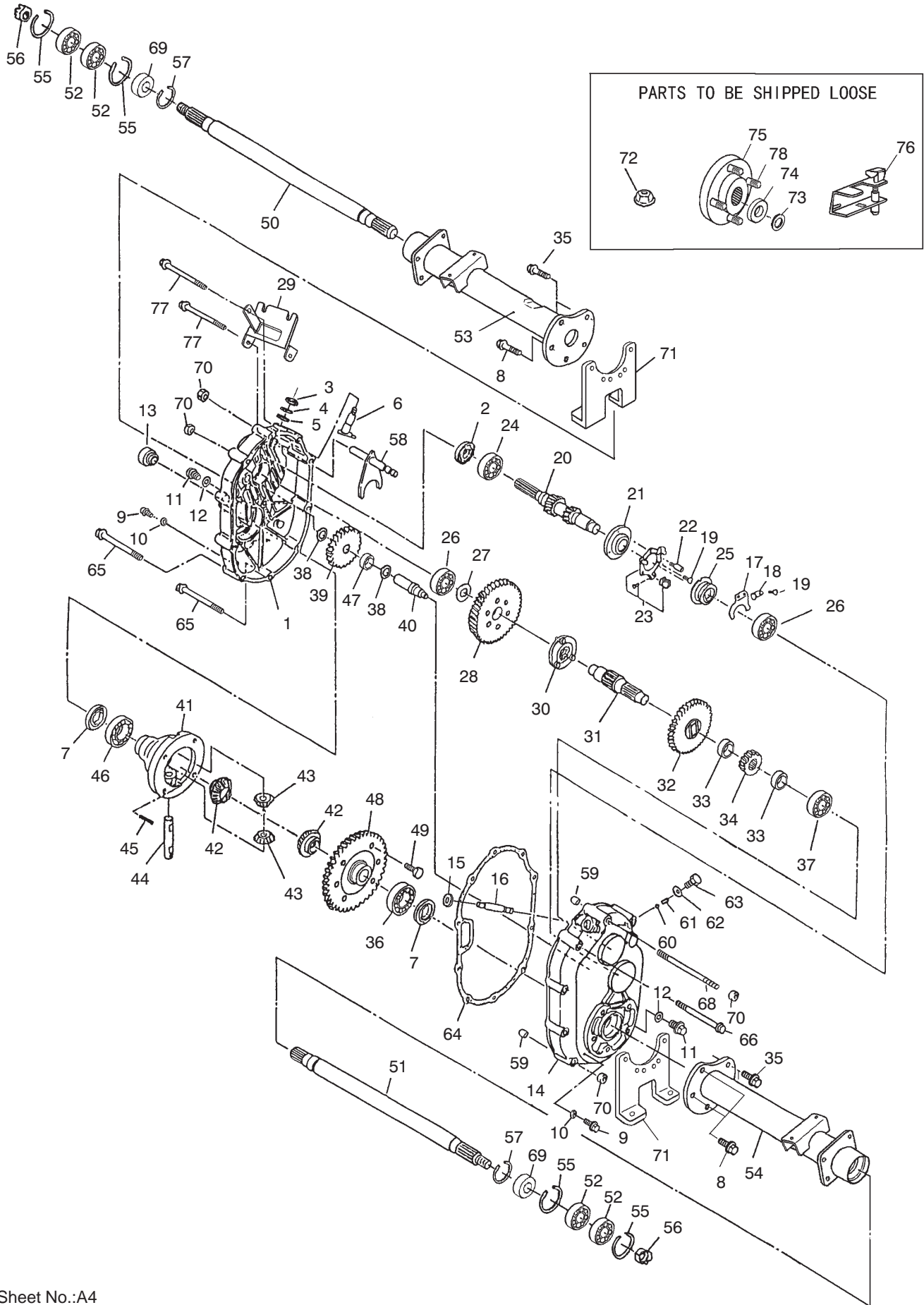

## Transaxle Assembly No. 104-6898

Ref. No.	Part No.	Qty.	Description
1	104-1601	1	Case-LH, Complete
2	104-1602	1	Seal-Oil
3	104-1603	1	Seal-Oil
4	104-1604	1	Ring-Snap
5	104-1605	1	Spacer
6	104-1606	1	Shaft-Selector
7	104-1607	2	Seal-Oil
8	104-1608	4	Bolt-Flange
9	104-1609	2	Plug-Check, Oil
10	104-1610	2	Gasket
11	104-1611	2	Plug-Drain, Oil
12	104-1612	2	Gasket
13	104-1613	1	Plug-Filler, Oil
14	104-1614	1	Case-Complete, RH
15	104-1615	1	Seal-Oil
16	104-1616	1	Shaft-Governor
17	104-1617	1	Fork-Governor
18	104-1618	1	Stopper
19	104-1619	4	Screw And Washer ASM
20	104-7002	1	Shaft-Input, Complete
21	104-1621	1	Base-Governor
22	104-1622	1	Pin-Lock
23	104-1623	1	Unit-Plate, Governor
24	104-1624	1	Bearing-Ball
25	104-1625	1	Sleeve-Governor
26	104-1626	2	Bearing-Ball
27	104-1627	1	Spacer
28	104-1628	1	Gear
29	104-1629	1	Bracket-Wire, Change
30	104-1630	1	Clutch-Pin
31	104-1631	1	Shaft-Center
32	104-1632	1	Gear-47
33	104-1633	2	Collar
34	104-1634	1	Gear
35	104-1635	6	Bolt-Flange
36	104-1636	1	Bearing-Ball
37	104-1637	1	Bearing-Ball
38	104-1638	2	Spacer
39	104-1639	1	Gear-34
40	104-1640	1	Shaft-Counter
41	104-1641	1	Case-Differential
42	104-1642	2	Gear-Side, Differential
43	104-1643	2	Pinion-Differential
44	104-1644	1	Shaft-Differential
45	104-1645	1	Pin
46	104-1646	1	Bearing-Ball
47	104-1647	1	Bearing-Needle
48	104-1648	1	Gear-62
49	104-1649	6	Bolt
50	104-1650	1	Shaft-Axle, LH
51	104-1651	1	Shaft-Axle, RH
52	104-1652	4	Bearing-Ball
53	104-1653	1	Case-Axle, LH
54	104-1654	1	Case-Axle, RH
55	104-1655	4	Ring-Snap
56	104-1656	2	Nut-Castle
57	104-1657	2	Ring-Snap
58	104-6870	1	Shaft-Shift, Complete
59	104-1659	2	Knock-Pipe

Ref. No.	Part No.	Qty.	Description
60	104-1660	1	Ball-Steel
61	104-1661	1	Spring
62	104-1662	1	Gasket
63	104-1663	1	Bolt
64	104-1664	1	Gasket
65	104-1665	6	Bolt-Flange
66	104-1666	1	Bolt-Flange
68	104-6866	1	Bolt
69	104-6867	2	Collar
70	33004-00	11	Nut-HF
71	104-1671	2	Bracket-Axle
72	104-1672	1	Nut-Lock
73	104-1673	2	Washer-Spring
74	104-1674	2	Washer
75	104-1675	2	Hub
76	104-6860	1	Lever-Select
77	104-6869	2	Bolt-Flange
78	104-8649	10	Stud





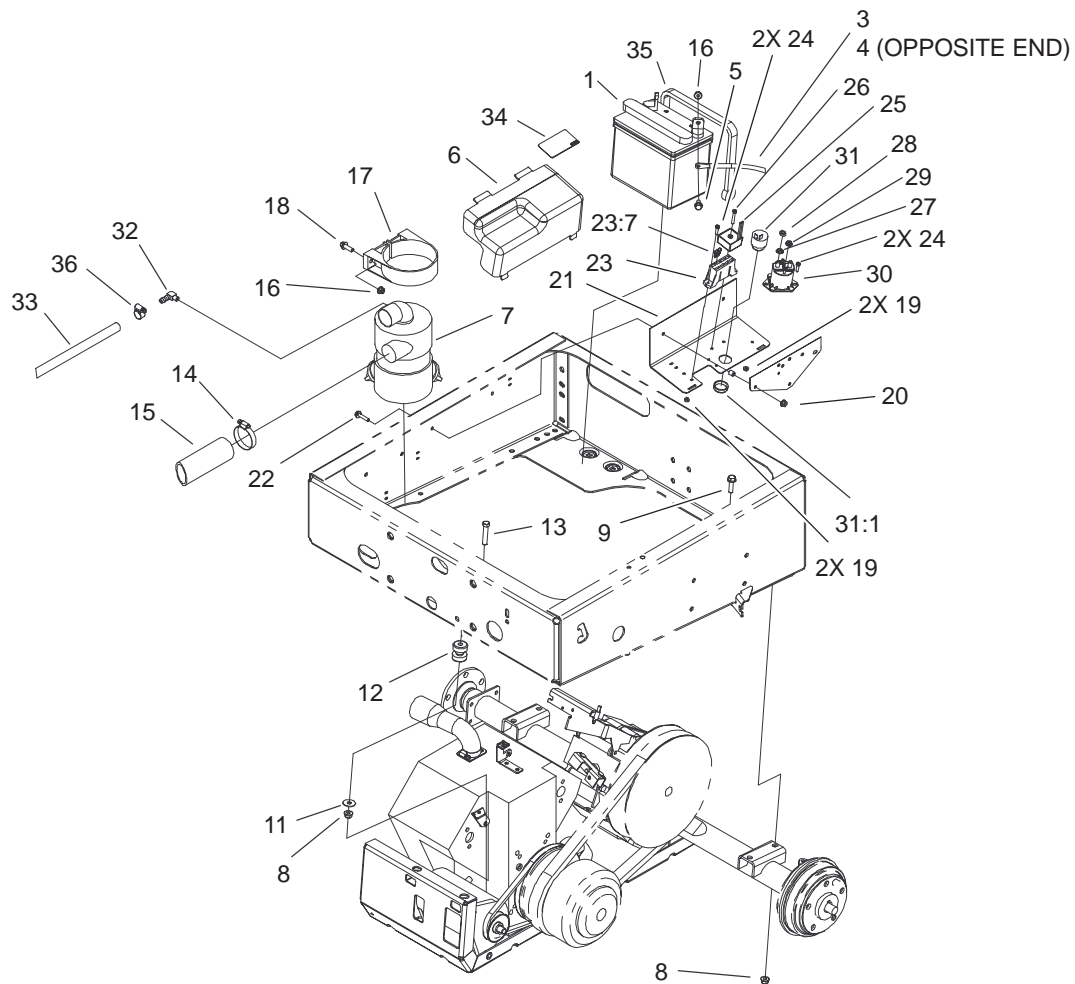

Sheet No.:10

## Drivetrain Mount Assembly

Ref. No.	Part No.	Qty.	Description	Ref. No.	Part No.	Qty.	Description
1	92-1678	1	Battery (Dry)	27	3255-8	2	Washer-Lock/Ext
3	99-7415	1	Cable-Negative	28	3218-2	2	Nut-Jam
4	99-7404	1	Cable-Positive	29	32149-8	2	Nut-Keps
5	3234-5	2	Screw	30	99-7406	1	Solenoid
6	99-7325	1	Cover-Electrical	31	80-9330	1	Alarm-Audio
7	99-7120	1	Filter-Air	31:1	104-5107	1	Nut-Plastic, Knurled
8	104-8301	6	Nut-Flange, NI	32	99-7230	1	Fitting-90°
9	3234-24	4	Screw-HHF	33	99-7842	1	Hose-Breather
11	3256-35	2	Washer-Flat	34	99-7352	1	Decal-Information
12	95-2596	2	Mount-Iso	35	99-7197	1	Strap-Epdm
13	323-10	2	Screw-HH	36	2412-36	2	Clamp-Hose
14	2412-130	1	Clamp-Hose				
15	104-6528	1	Hose-Intake				
16	104-8300	4	Nut-Flange, NI				
17	95-5806	1	Bracket-Mounting				
18	3234-17	2	Screw-HHF				
19	3296-2	5	Nut-Lock				
20	32128-32	2	Nut-HHF				
21	99-7051-03	1	Mount-Component				
22	3234-21	2	Screw-Cap				
23	99-7434	1	Harness-Wire, Main				
23:7	218-578	3	Fuse-10 Amp				
*23:8	100-4918	1	Diode				
24	32105-13	4	Screw-SHH				
25	104-6927	1	Regulator				
26	32105-1	1	Screw-SHH				

\* Not illustrated

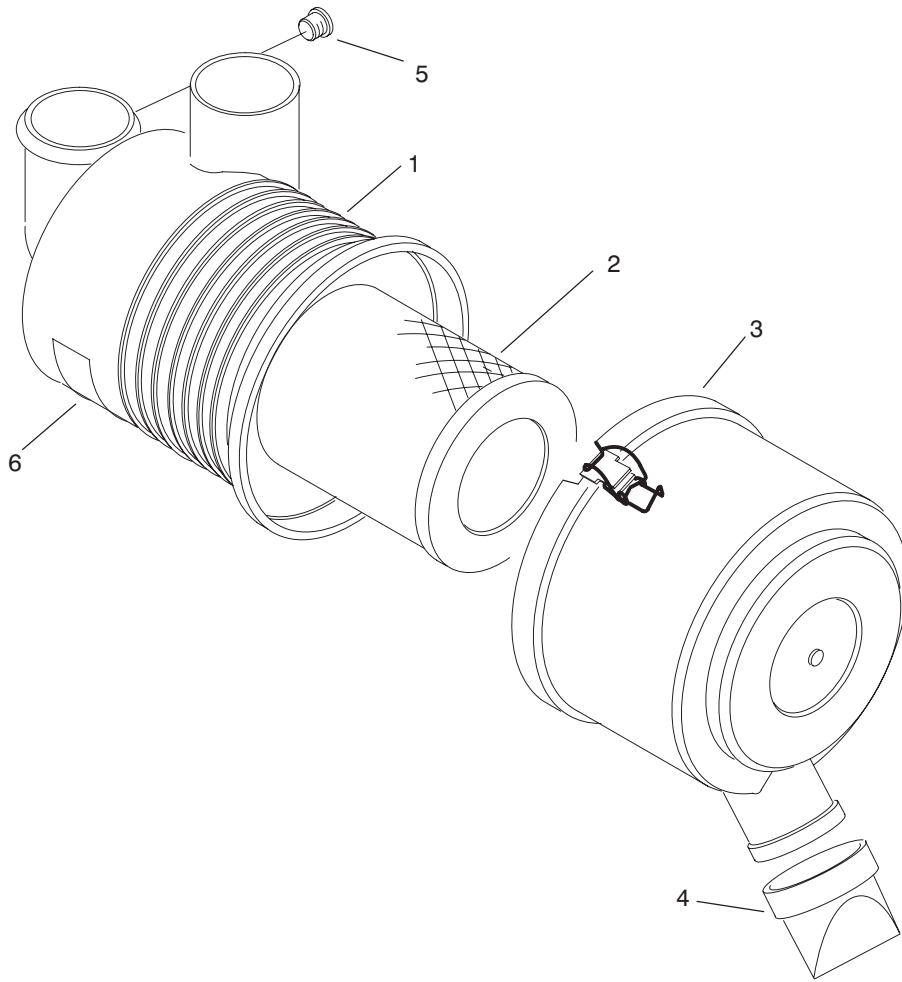

Sheet No.:A7  
T-2201

### Air Filter Assembly No. 99-7120

Ref. No.	Part No.	Qty.	Description
☆1		1	Body
2	93-2195	1	Filter
3	94-3652	1	Cover ASM
4	87-9400	1	Valve-Vacuator
☆5		1	Plug
☆6		1	Marking

Ref. No.	Part No.	Qty.	Description

☆ Not serviced separately









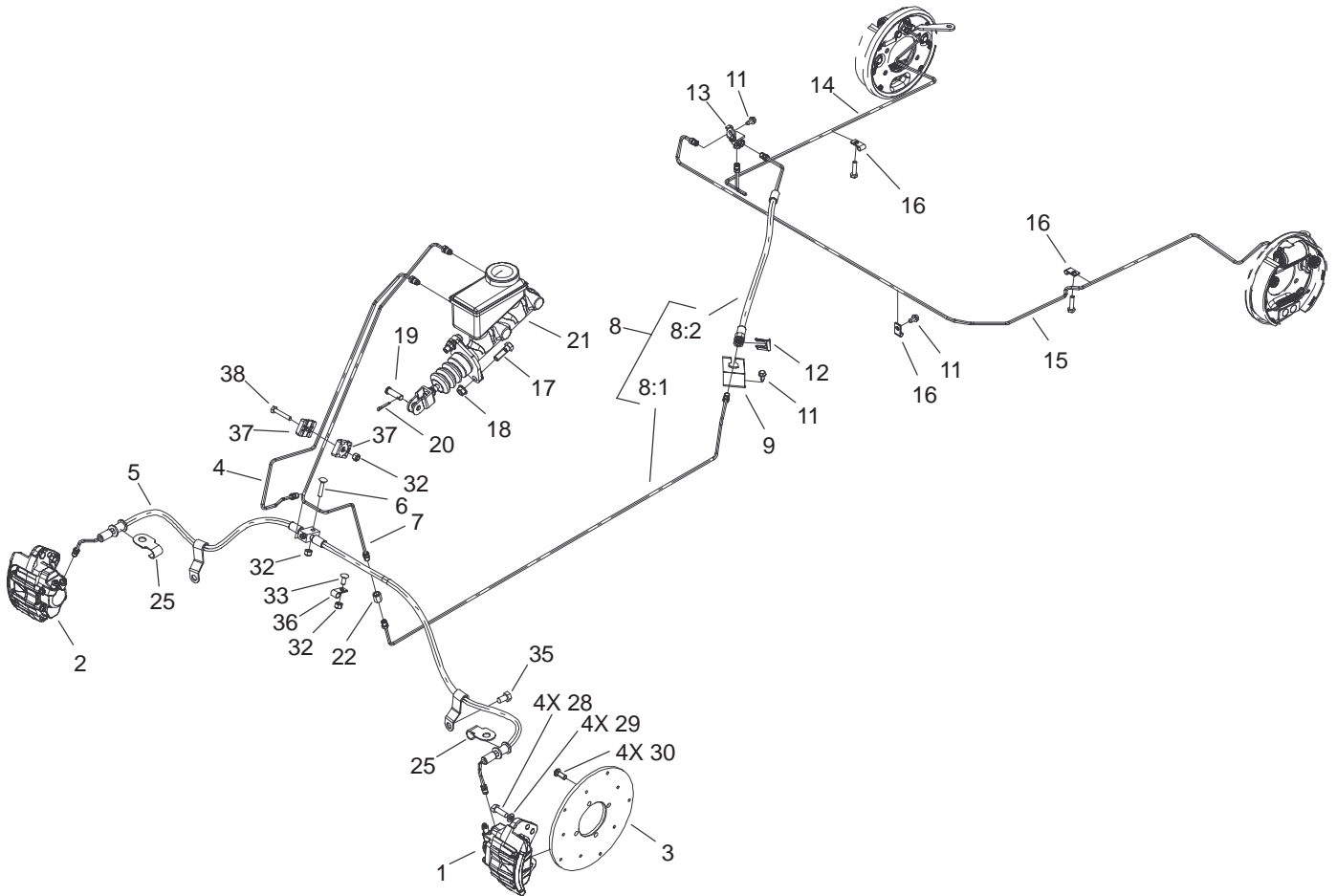

Sheet No.:18

## Brake and Master Cylinder Assembly

Ref. No.	Part No.	Qty.	Description
1	104-6801	1	Caliper-LH
2	104-6802	1	Caliper-RH
3	104-6891	2	Rotor
4	104-6798	1	Tube-Front, Brake
5	104-6792	1	Brake Front Hose ASM
6	3229-3	1	Screw-CARR
7	104-6793	1	Tube-Brake, Rear
8		1	Complete Rear Brake Hose ASM
8:1	104-6794	1	Tube-Brake, Rear
8:2	104-6795	1	Hose-Brake, Rear
9	104-6799	1	Bracket-Hose, Brake
11	12-3270	3	Screw
12	104-7092	1	Clip
13	87-3560	1	Tee
14	104-6796	1	Tube-Brake Rear, RH
15	104-6797	1	Tube-Brake Rear, LH
16	2412-72	3	Clip-Closed, Insulated
17	323-6	2	Screw-HH
18	3290-357	2	Nut-HHF
19	283-2	1	Pin-Clevis
20	3272-10	1	Pin-Cotter
21	104-6782	1	Cylinder-Master
22	87-3570	1	Union
25	104-7073	2	Bracket-Hose

Ref. No.	Part No.	Qty.	Description
28	33114-025	8	Screw-HH
29	3253-4	8	Washer-Lock
30	3274-55	8	Screw-HSBH
32	3296-42	3	Nut-Lock, NI
33	3229-11	1	Screw-CARR
35	32144-69	2	Screw-HH
36	2412-89	1	Clamp
37	87-7660	2	Clamp-Tube
38	321-9	1	Screw-HH

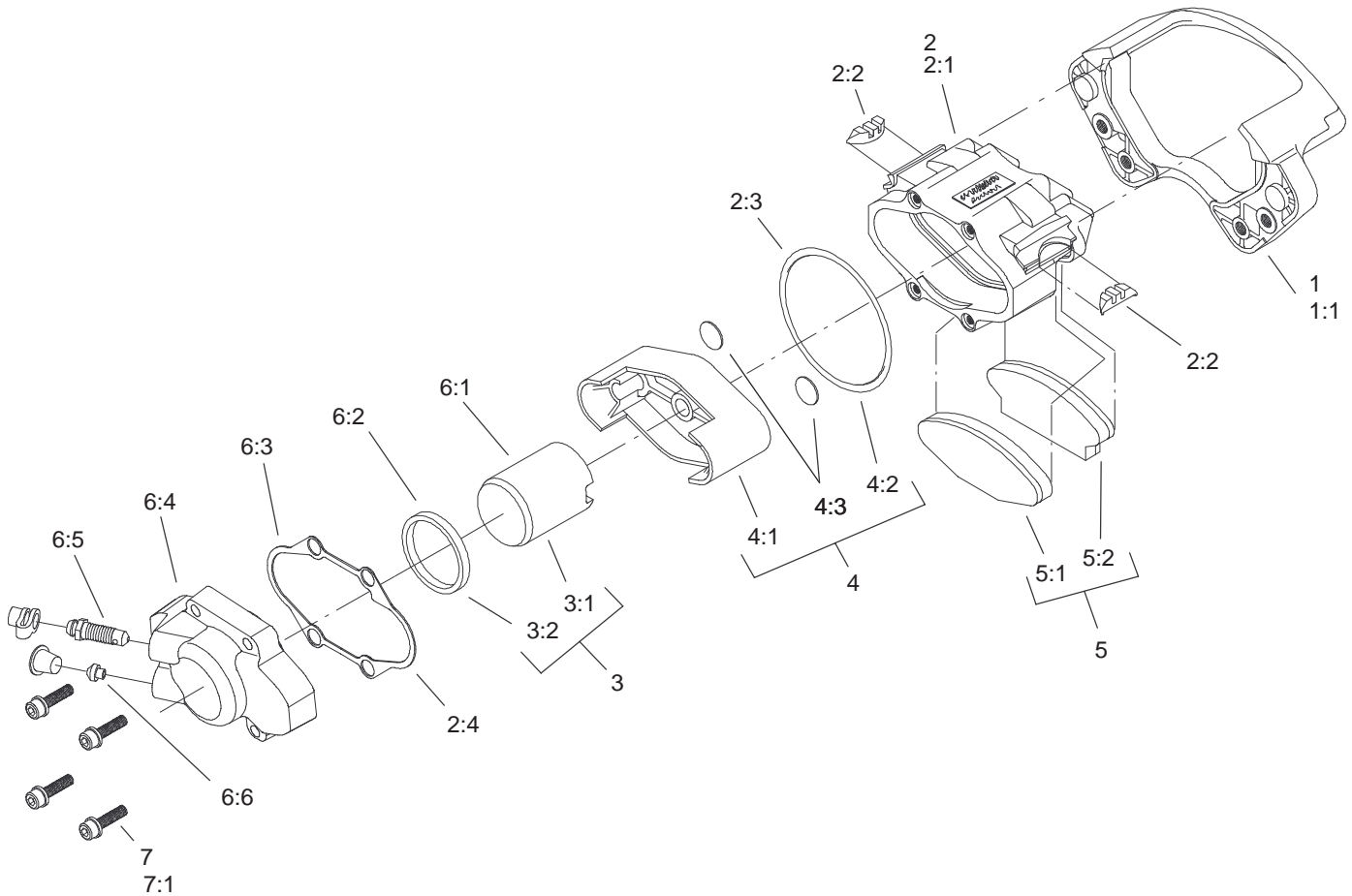

Sheet No.:B1

## Left Hand Caliper Assembly No. 104-6801

Ref. No.	Part No.	Qty.	Description
1	105-9311	1	Bracket Kit
☆1:1		1	Bracket
2	105-9312	1	Housing Kit
☆2:1		1	Housing
☆2:2		2	Spring-Rubber
☆2:3		1	O-Ring
☆2:4		1	Gasket
3	105-9313	1	Piston & Seal Kit
☆3:1		1	Piston-Round
☆3:2		1	Seal-Square
4	105-9314	1	Piston & O-Ring Kit
☆4:1		1	Piston-Oval
☆4:2		1	O-Ring
☆4:3		2	Plug-Piston
5	105-9315	1	Pad Kit
☆5:1		2	Pad/Holder ASM
☆5:2		2	Pad/Holder ASM
6	105-9317	1	LH Piston & Cover ASM Kit
☆6:1		1	Piston-Round
☆6:2		1	Seal-Square
☆6:3		1	Gasket
☆6:4		1	Cover
☆6:5		1	Screw-Bleeder
☆6:6		1	Insert-Seat

Ref. No.	Part No.	Qty.	Description
7	105-9318	1	Bolt Kit
☆7:1		4	Screw-Cover

☆ Not serviced separately

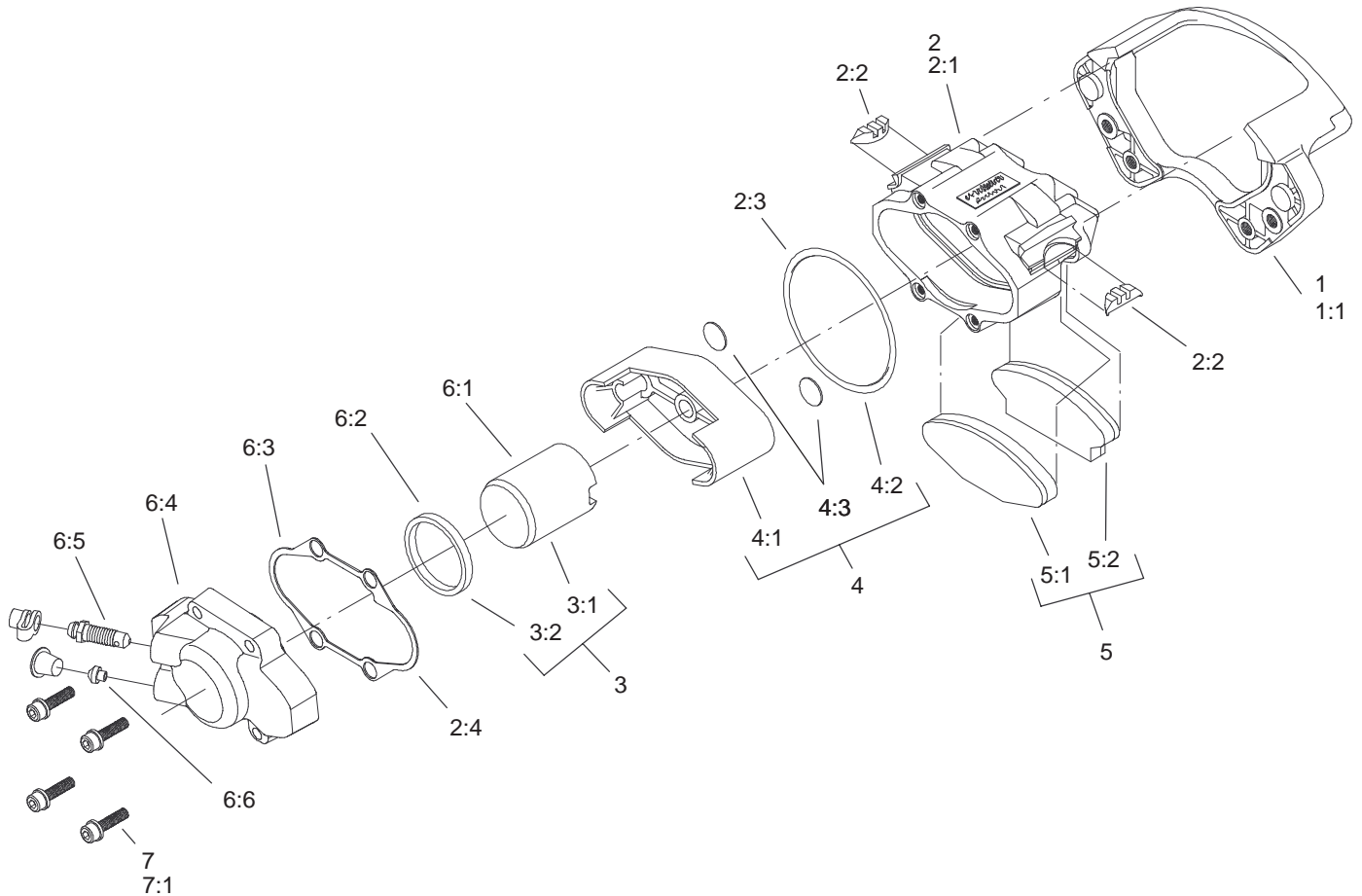

Sheet No.:B2

## Right Hand Caliper Assembly No. 104-6802

Ref. No.	Part No.	Qty.	Description
1	105-9311	1	Bracket Kit
☆1:1		1	Bracket
2	105-9312	1	Housing Kit
☆2:1		1	Housing
☆2:2		2	Spring-Rubber
☆2:3		1	O-Ring
☆2:4		1	Gasket
3	105-9313	1	Piston & Seal Kit
☆3:1		1	Piston-Round
☆3:2		1	Seal-Square
4	105-9314	1	Piston & O-Ring Kit
☆4:1		1	Piston-Oval
☆4:2		1	O-Ring
☆4:3		2	Plug-Piston
5	105-9315	1	Pad Kit
☆5:1		2	Pad/Holder ASM
☆5:2		2	Pad/Holder ASM
6	105-9316	1	RH Piston & Cover ASM Kit
☆6:1		1	Piston-Round
☆6:2		1	Seal-Square
☆6:3		1	Gasket
☆6:4		1	Cover
☆6:5		1	Screw-Bleeder
☆6:6		1	Insert-Seat

Ref. No.	Part No.	Qty.	Description
7	105-9318	1	Bolt Kit
☆7:1		4	Screw-Cover

☆ Not serviced separately



# Electrical Schematic

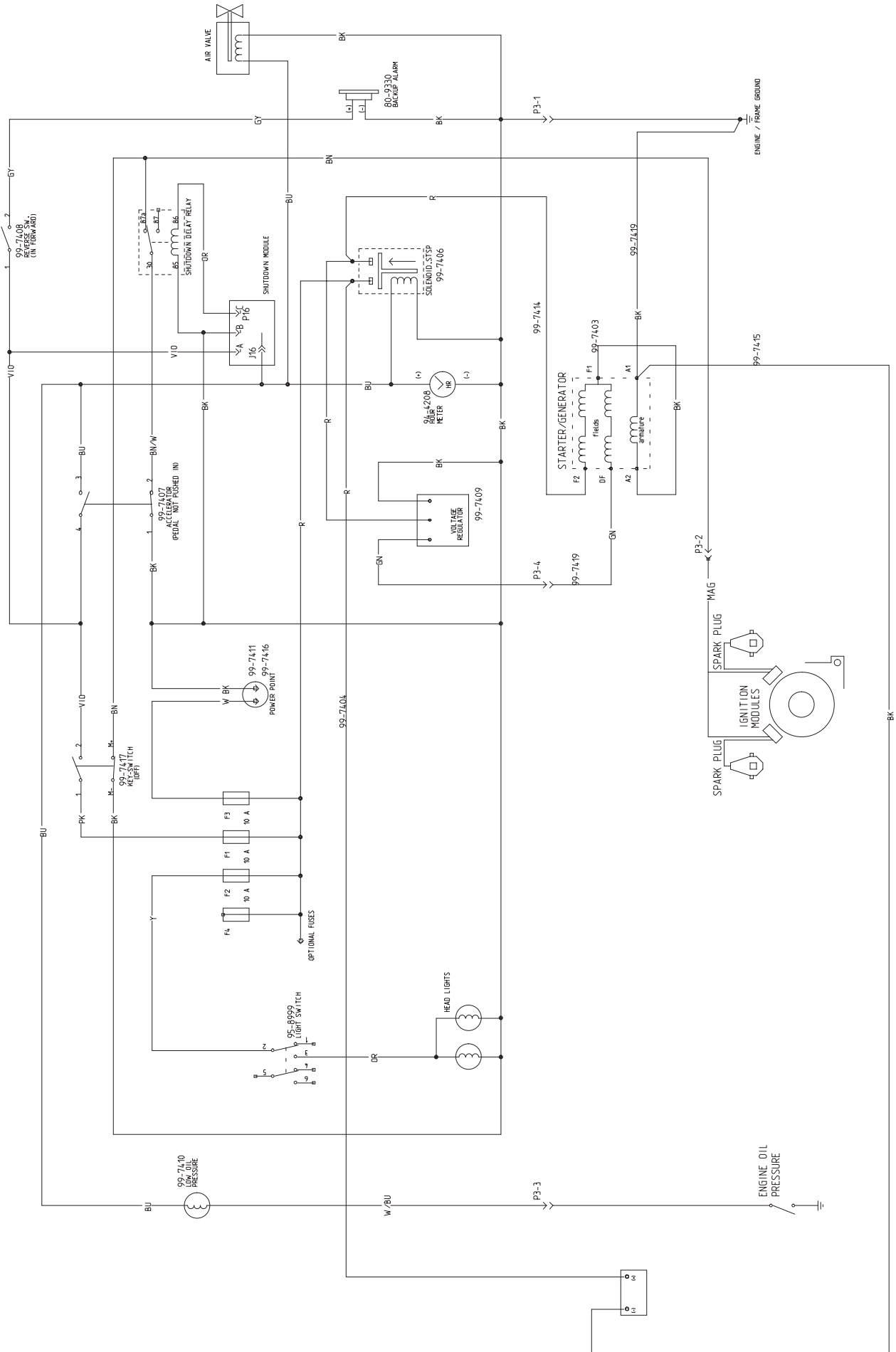





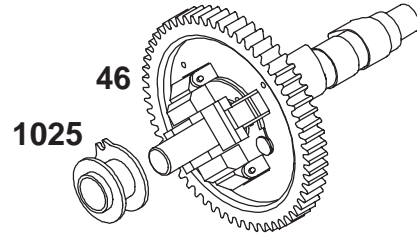
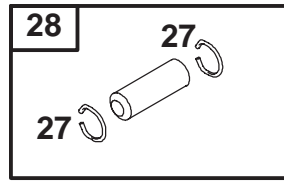
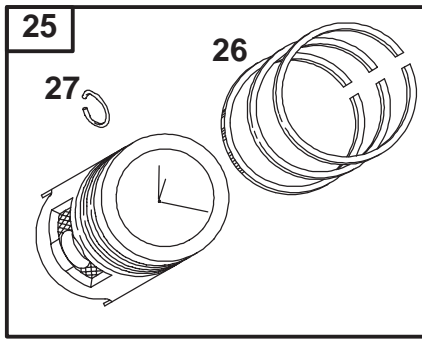
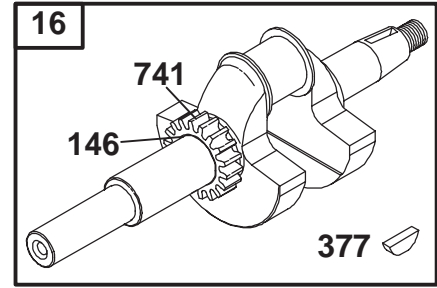
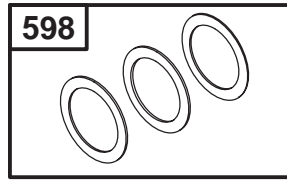
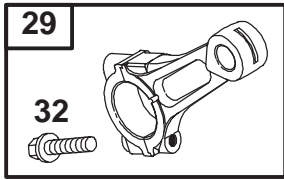

Assemblies include all parts shown in frames.

### Crankshaft Assembly

Ref. No.	Part No.	Qty.	Description
16	692163	1	Crankshaft
25	807619	1	Piston Assembly (Standard)
	807807	1	Piston Assembly (.010" Oversize)
	807809	1	Piston Assembly (.020" Oversize)
	807811	1	Piston Assembly (.030" Oversize)
26	807620	1	Ring Set (Standard)
	807808	1	Ring Set (.010" Oversize)
	807810	1	Ring Set (.020" Oversize)
	807812	1	Ring Set (.030" Oversize)
27	690683	1	Lock-Piston Pin
28	807621	1	Pin-Piston
29	807900	1	Rod-Connecting (Standard)
	807809	1	Rod-Connecting (.020" Undersize)
32	690698	1	Screw (Connecting Rod)

Ref. No.	Part No.	Qty.	Description
46	692157	1	Camshaft
146	691639	1	Key-Timing
377	808095	1	Key-Woodruff
598	807625	1	Shim-End Play
741	691530	1	Gear-Timing
1025	690689	1	Slider-Governor

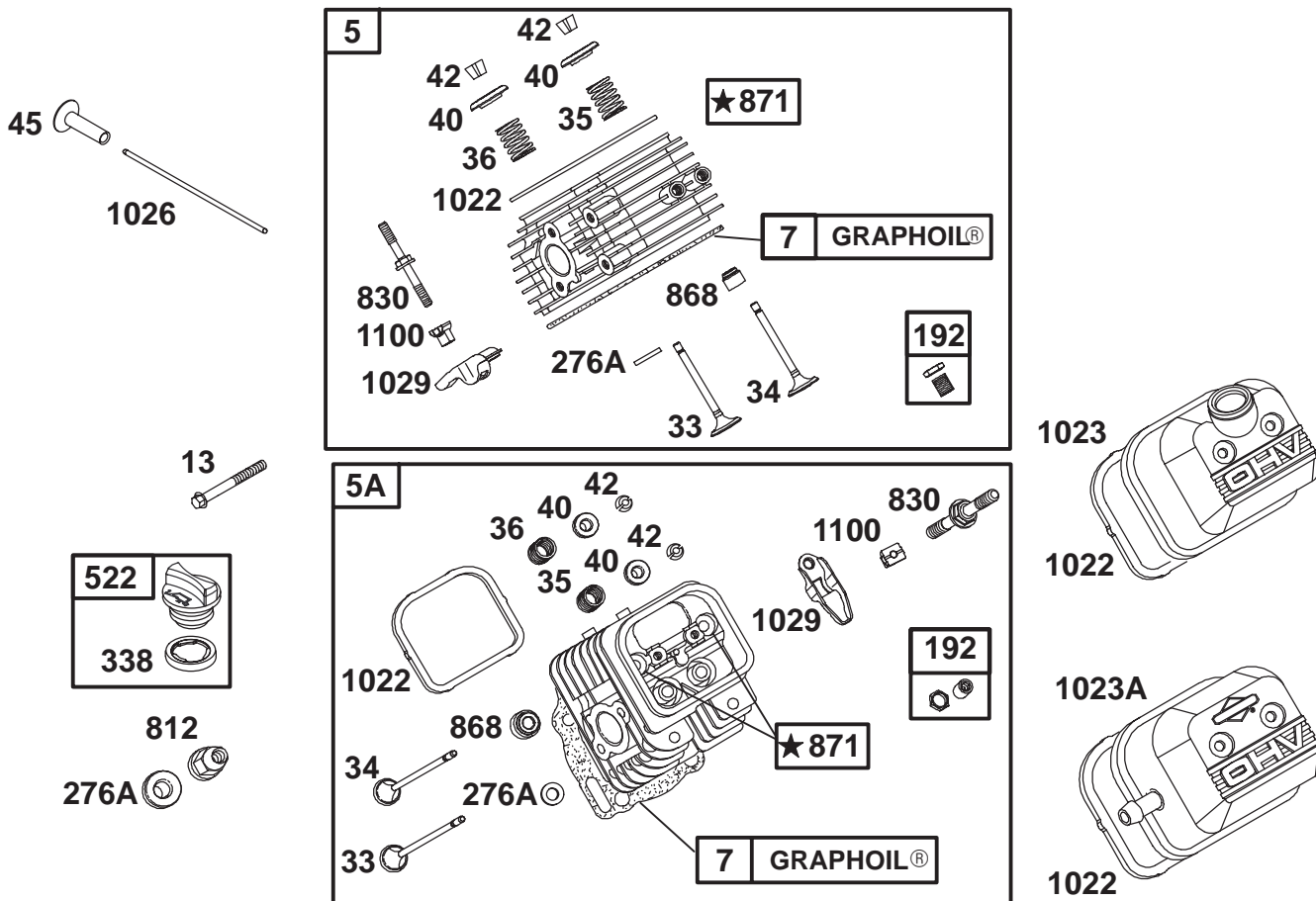

Assemblies include all parts shown in frames.

## Cylinder Head Assembly

Ref. No.	Part No.	Qty.	Description
5	808381	1	Head-Cylinder (Cylinder 1)
5A	808382	1	Head-Cylinder (Cylinder 2)
★Δ7	806085	1	Gasket-Cylinder Head
13	692059	1	Screw (Cylinder Head)
33	807681	1	Valve-Exhaust
34	807680	1	Valve-Intake
35	692084	1	Spring-Valve (Intake)
36	692084	1	Spring-Valve (Exhaust)
40	692058	1	Retainer-Valve
42	807683	1	Keeper-Valve
45	690977	1	Tappet-Valve
192	807623	1	Adjuster-Rocker Arm
★Δ276A	691766	1	Washer-Sealing
★Δ338	691312	1	Gasket-Dipstick
522	491832	1	Plug-Dipstick/Fill
812	692055	1	Nut (Rocker Cover)
830	691544	1	Stud-Rocker Arm
★Δ868	691963	1	Seal-Valve
★871	692057	1	Bushing-Valve Guide
★Δ1022	806039	1	Gasket-Rocker Cover

Ref. No.	Part No.	Qty.	Description
1023	690758	1	Cover-Valve
1023A	691558	1	Cover-Valve
1026	691836	1	Rod-Push (Intake)
	691758	1	Rod-Push (Exhaust)
1029	691543	1	Arm-Rocker
1100	690973	1	Pivot-Rocker Arm

Δ Included in Valve Gasket Set-Ref. 1095.

★ Included in Engine Gasket Set-Ref. 358.

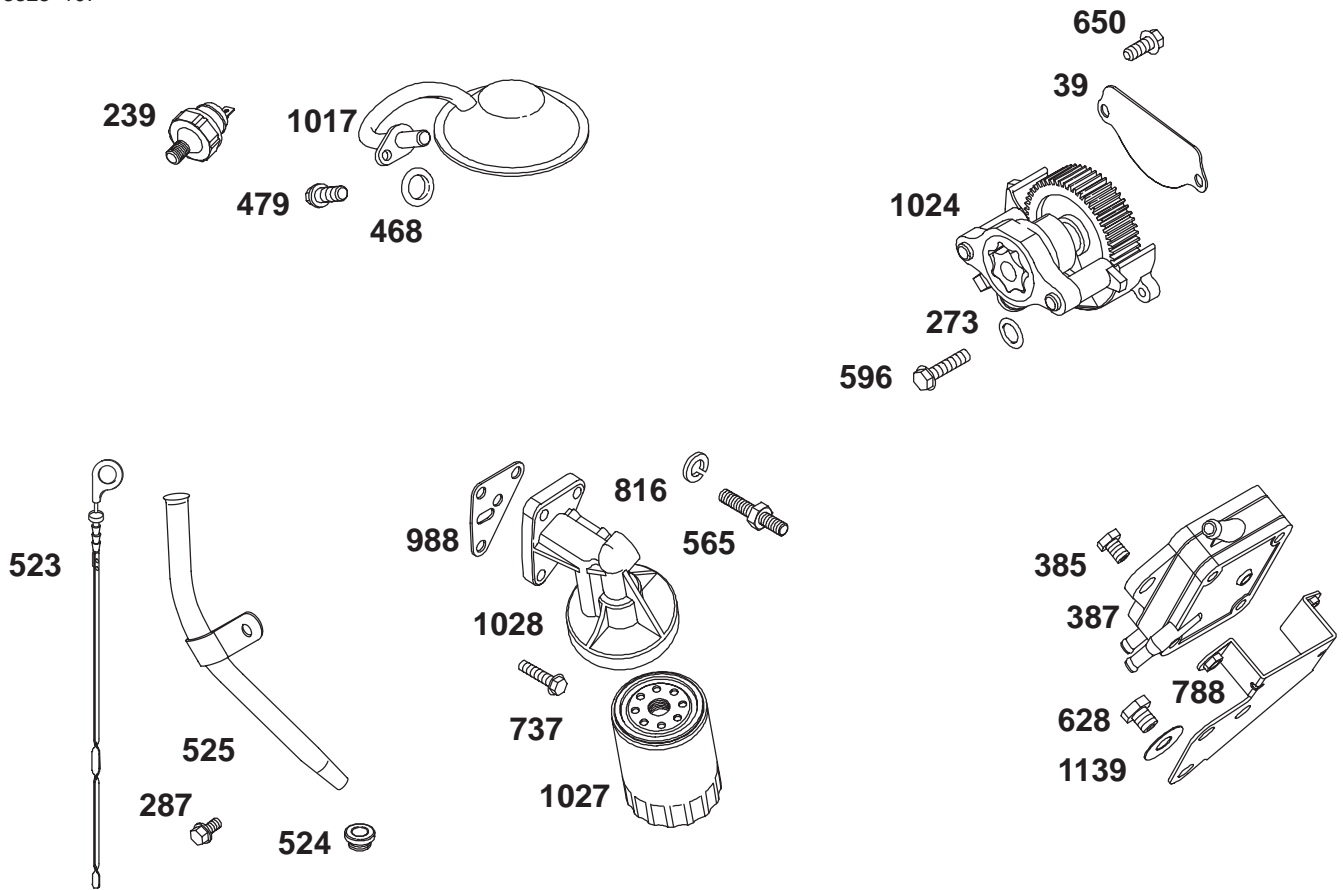

Assemblies include all parts shown in frames.

## Oil Filter, Tube and Pump Assembly

Ref. No.	Part No.	Qty.	Description
39	690745	1	Deflector-Oil
239	690233	1	Switch-Oil Pressure
273	690681	1	Seal-O Ring (Oil Pump)
287	692062	1	Screw (Dipstick Tube)
385	693169	1	Screw (Fuel Pump)
387	808656	1	Pump-Fuel
★468	690690	1	Seal-O Ring (Oil Pump Screen)
479	692537	1	Screw (Oil Pump Screen)
523	693175	1	Dipstick
★524	693172	1	Seal-Dipstick Tube
525	693173	1	Tube-Dipstick
565	690682	1	Stud (Oil Filter Adapter)
596	691492	1	Screw (Oil Pump)
628	806660	1	Screw (Fuel Pump Bracket)
650	692539	1	Screw (Oil Deflector)
737	690679	1	Screw (Oil Filter Adapter)

Ref. No.	Part No.	Qty.	Description
788	691559	1	Bracket-Fuel Pump
816	690706	1	Washer (Oil Filter Adapter)
★988	692063	1	Gasket-Oil Filter Adapter
1017	690900	1	Screen-Oil Pump
1024	693185	1	Pump-Oil
1027	492932	1	Filter-Oil
1028	808235	1	Adapter-Oil Filter
1139	806497	1	Washer (Fuel Pump Bracket)

★ Included in Engine Gasket Set-Ref. 358.

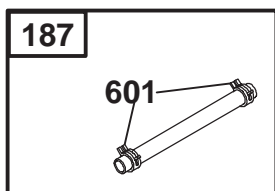
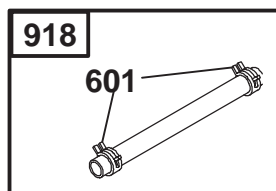
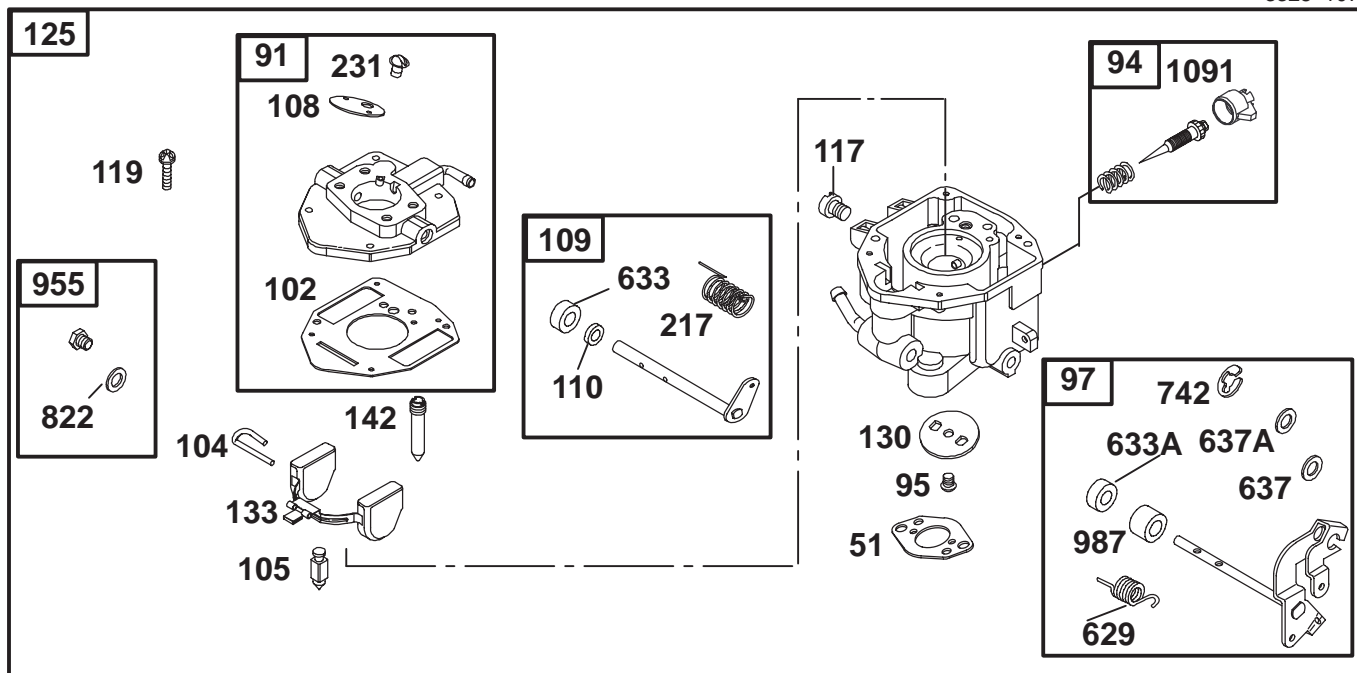

Assemblies include all parts shown in frames.

## Carburetor Assembly

Ref. No.	Part No.	Qty.	Description
★●51	691694	1	Gasket-Intake
91	808964	1	Body-Upper Carburetor
●94	808257	1	Kit-Idle Mixture
95	690718	1	Screw (Throttle Valve)
97	809095	1	Shaft-Throttle
●102	692077	1	Gasket-Carburetor Body
●104	690723	1	Pin-Float Hinge
●105	692078	1	Valve-Float Needle
108	690719	1	Valve-Choke
109	808962	1	Shaft-Choke
110	806861	1	Washer (Choke Shaft)
117	806859	1	Jet-Main
119	690720	1	Screw (Upper to Lower Body)
125	809152	1	Carburetor
130	690726	1	Valve-Throttle
133	806961	1	Float-Carburetor
142	806860	1	Nozzle-Carburetor
187	691050	1	Line-Fuel (Cut to Required Length)

Ref. No.	Part No.	Qty.	Description
217	806862	1	Spring-Choke Return
231	690718	1	Screw (Choke Valve)
601	691038	1	Clamp-Hose
629	807004	1	Spring-Throttle Return
●633	807003	1	Seal-Choke/Throttle Shaft
●633A	690722	1	Seal-Choke/Throttle Shaft
637	806999	1	Washer (Throttle Shaft)
637A	807000	1	Washer (Throttle Shaft)
742	807001	1	Retainer-E Ring
822	690724	1	Seal-O Ring (Carburetor Plug)
918	393815	1	Line-Vacuum (Cut to Required Length)
947	692094	1	Solenoid-Fuel
955	807723	1	Plug-Carburetor
987	807002	1	Seal-Throttle Shaft
●1091	691516	1	Cap-Limiter

△ Included in Valve Gasket Set-Ref. 1095.  
 ★ Included in Engine Gasket Set-Ref. 358.

● Included in Carburetor Overhaul Kit-Ref. 121.

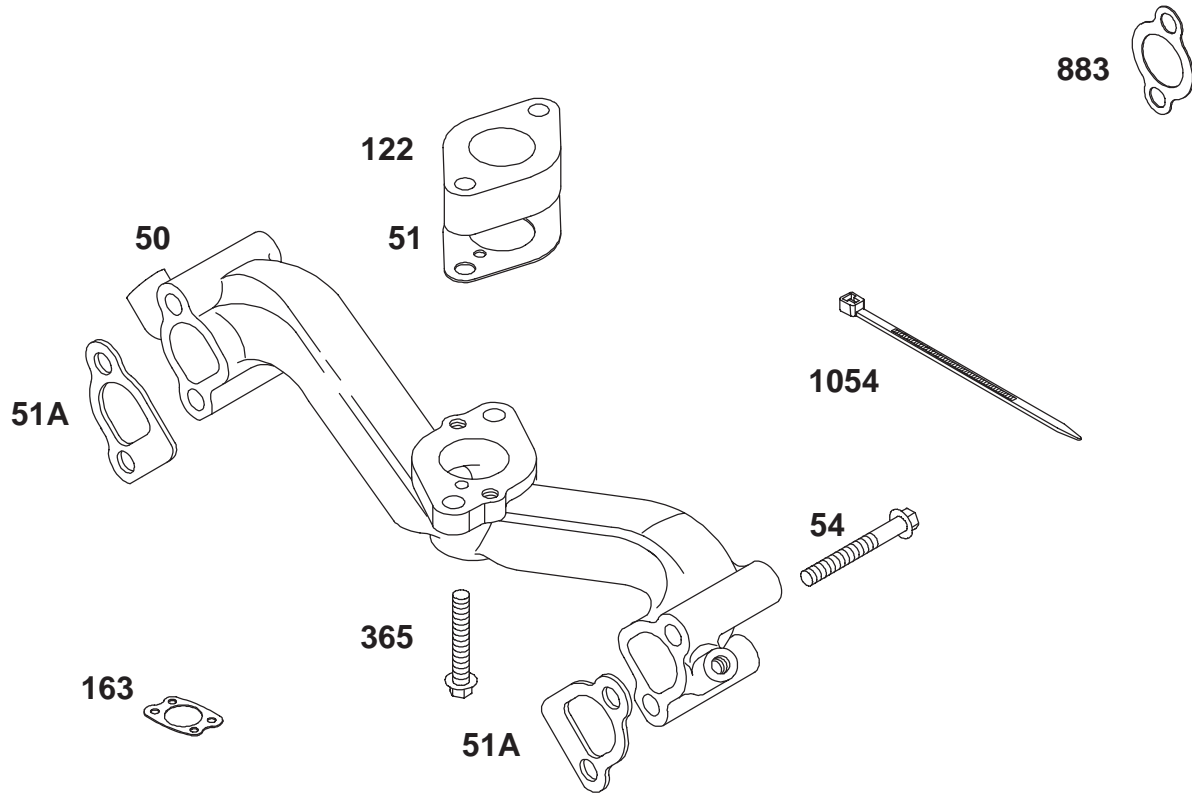

Assemblies include all parts shown in frames.

## Intake Manifold Assembly

Ref. No.	Part No.	Qty.	Description
50	690754	1	Manifold-Intake
★●51	691694	1	Gasket-Intake
★△51A	692035	1	Gasket-Intake
54	690676	1	Screw (Intake Manifold)
122	690691	1	Spacer-Carburetor
★163	692081	1	Gasket-Air Cleaner
365	690711	1	Screw (Carburetor)
★△883	691613	1	Gasket-Exhaust
1054	280275	1	Tie-Cable

Ref. No.	Part No.	Qty.	Description

△ Included in Valve Gasket Set-Ref. 1095.

★ Included in Engine Gasket Set-Ref. 358.

● Included in Carburetor Overhaul Kit-Ref. 121.

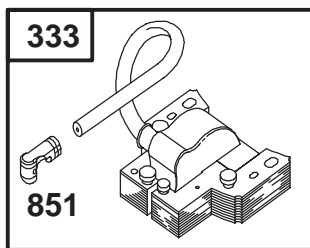

334

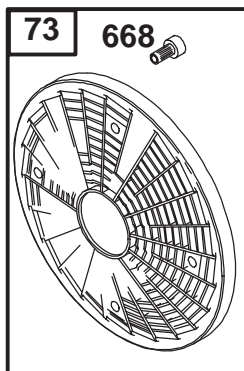
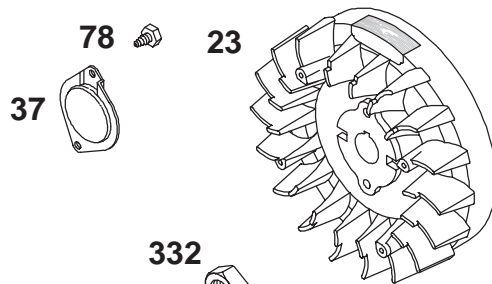

74

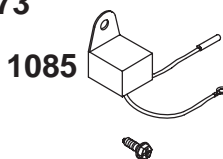
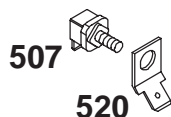

1231



529

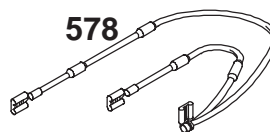

578

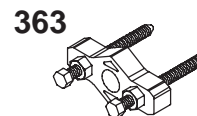

363

Assemblies include all parts shown in frames.

### Flywheel Assembly

Ref. No.	Part No.	Qty.	Description
23	690889	1	Flywheel
37	690715	1	Guard-Flywheel
73	494439	1	Screen-Rotating
74	691647	1	Screw (Rotating Screen)
78	690688	1	Screw (Flywheel Guard)
332	690887	1	Nut (Flywheel)
333	492341	1	Armature-Magneto
334	692066	1	Screw (Magneto Armature)
359	691077	1	Washer (Ground Terminal)
363	19203	1	Puller-Flywheel
373	691612	1	Nut (Ground Terminal)
507	691972	1	Insulator
520	691084	1	Terminal-Ground
529	690744	1	Grommet
578	692319	1	Wire Assembly
668	691500	1	Spacer
729	690586	1	Clip-Wire
851	493880	1	Terminal-Sparkplug
1085	809093	1	Module-Ignition

Ref. No.	Part No.	Qty.	Description
1231	692067	1	Screw (Ignition Module)

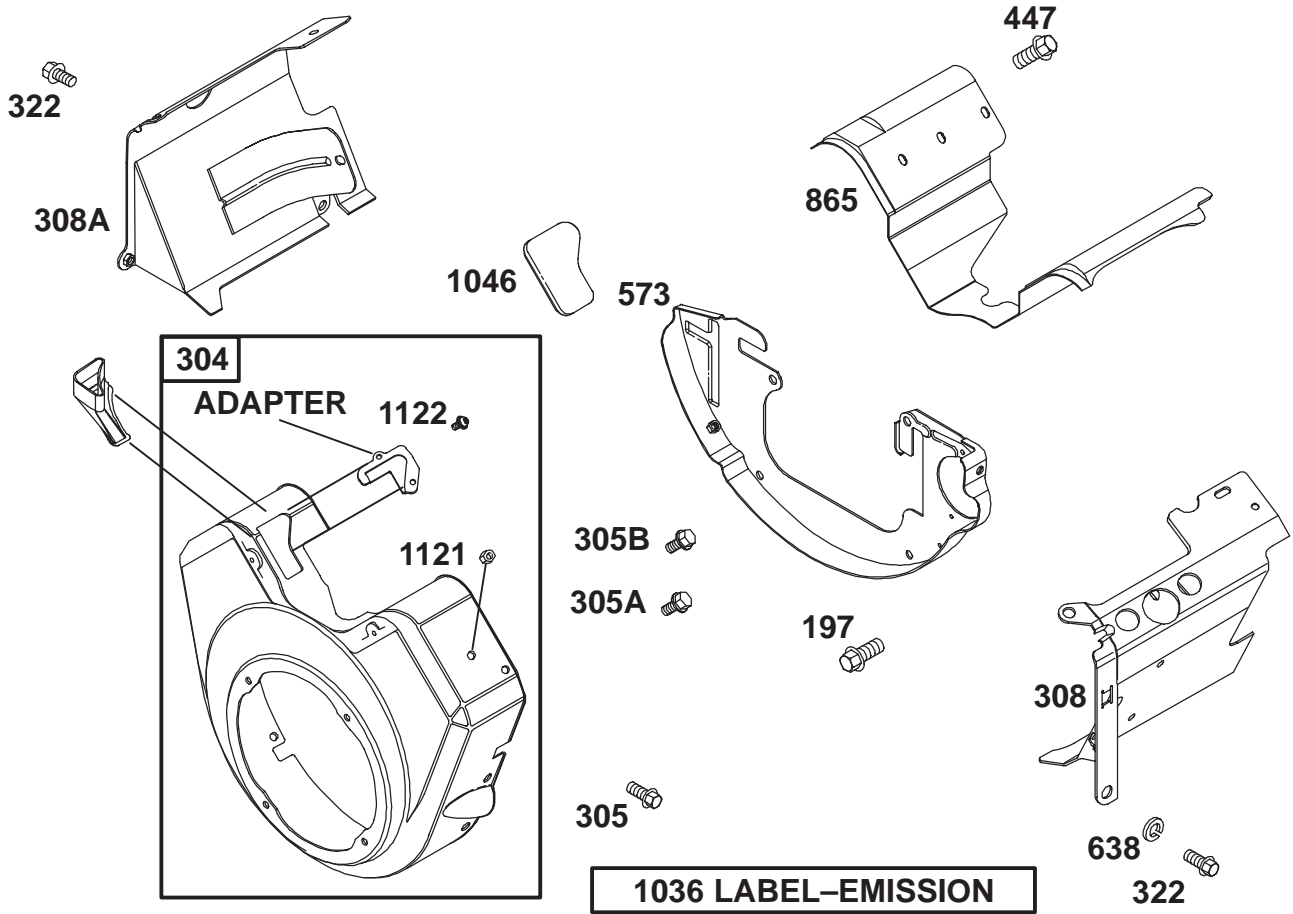

Assemblies include all parts shown in frames.

## Blower Housing Assembly

Ref. No.	Part No.	Qty.	Description
197	692539	1	Screw (Backplate)
304	808408	1	Housing-Blower
305	692539	1	Screw (Blower Housing)
305A	692056	1	Screw (Blower Housing)
305B	692062	1	Screw (Blower Housing)
308	806547	1	Cover-Cylinder Head (Cylinder 1)
308A	806546	1	Cover-Cylinder Head (Cylinder 2)
322	692539	1	Screw (Cylinder Head Cover)
447	692539	1	Screw (Air Guide Cover)
573	690902	1	Plate-Back
638	691551	1	Washer (Cylinder Head Cover)
865690750		1	Cover-Air Guide
1036	806881	1	Label-Emission
1046	692082	1	Plug-Blower Housing
1121	810056	1	Nut (Air Cleaner)

Ref. No.	Part No.	Qty.	Description
1122	93410	1	Screw (Control Wire Casing)

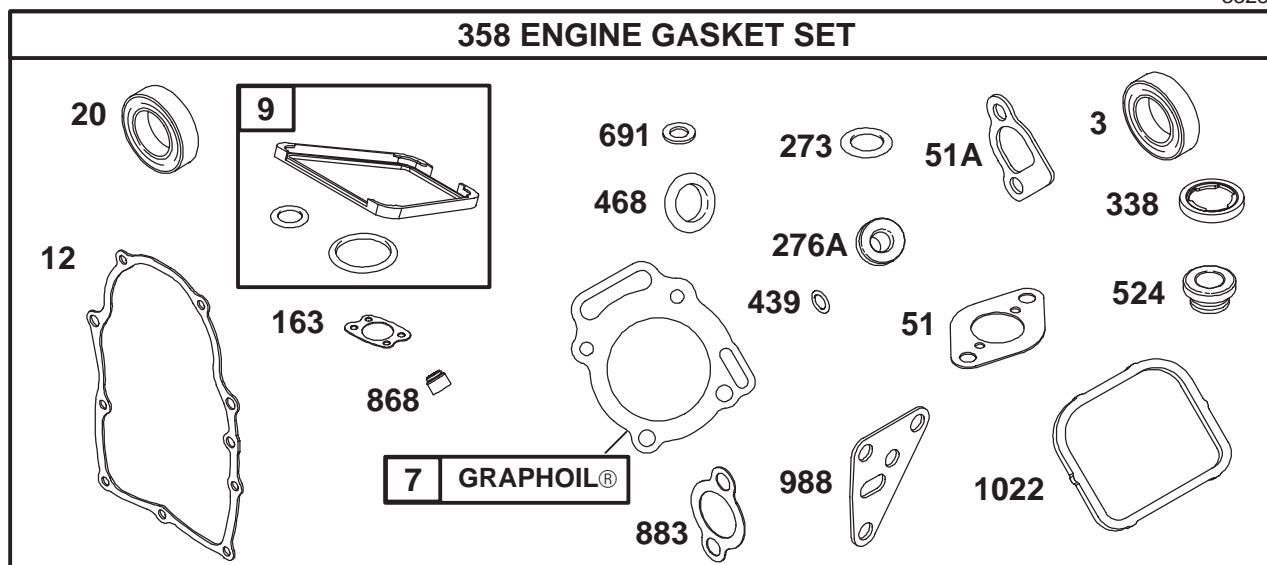

Assemblies include all parts shown in frames.

## Gasket Assembly

Ref. No.	Part No.	Qty.	Description
★3	805101	1	Seal—Oil (Magneto Side)
★Δ7	806085	1	Gasket—Cylinder Head
★9	809094	1	Gasket—Breather
★12	691684	1	Gasket—Crankcase
★20	805049	1	Seal—Oil (PTO Side)
★●51	691694	1	Gasket—Intake
★Δ51A	692035	1	Gasket—Intake
★163	692081	1	Gasket—Air Cleaner
★273	690681	1	Seal—O Ring (Oil Pump)
★Δ276A	691766	1	Washer—Sealing
★Δ338	691312	1	Gasket—Dipstick
358	808390	1	Gasket Set—Engine
★439	692154	1	Seal—O Ring (Crankcase Cover)
★468	690690	1	Seal—O Ring (Oil Pump Screen)
★524	693172	1	Seal—Dipstick Tube
★691	690680	1	Seal—Governor Shaft
★Δ868	691963	1	Seal—Valve
★Δ883	691613	1	Gasket—Exhaust
★988	692063	1	Gasket—Oil Filter

Ref. No.	Part No.	Qty.	Description
★Δ1022	806039	1	Adapter Gasket—Rocker Cover

Δ Included in Valve Gasket Set—Ref. 1095.

★ Included in Engine Gasket Set—Ref. 358.

● Included in Carburetor Overhaul Kit—Ref. 121.

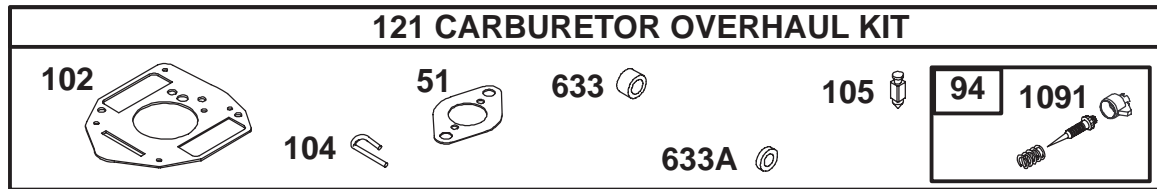
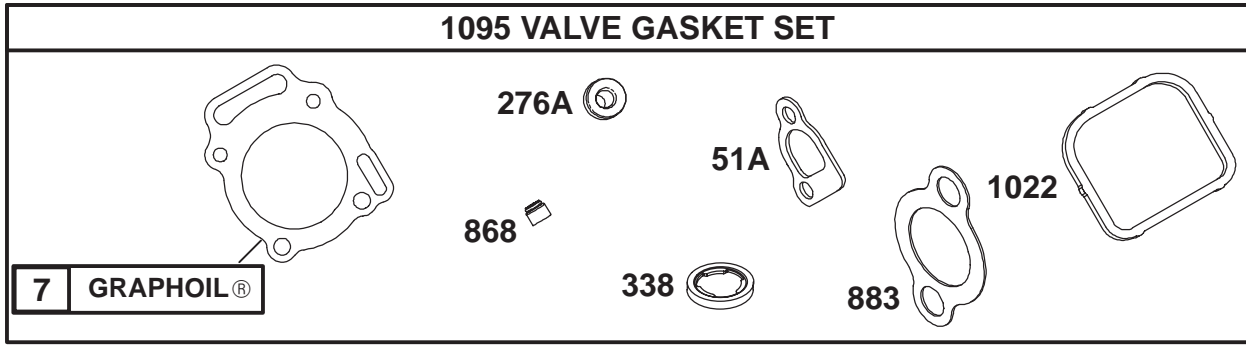

Assemblies include all parts shown in frames.

### Carburetor Overhaul Kit Assembly

Ref. No.	Part No.	Qty.	Description
★△7	806085	1	Gasket-Cylinder Head
★●51	691694	1	Gasket-Intake
★△51A	692035	1	Gasket-Intake
●94	808257	1	Kit-Idle Mixture
●102	692077	1	Gasket-Carburetor Body
●104	690723	1	Pin-Float Hinge
●105	692078	1	Valve-Float Needle
121	809023	1	Kit-Carburetor Overhaul
★△276A	691766	1	Washer-Sealing
★△338	691312	1	Gasket-Dipstick
●633	806131	1	Seal-Choke/Throttle Shaft
●633A	690722	1	Seal-Choke/Throttle Shaft
★△868	691963	1	Seal-Valve
★△883	691613	1	Gasket-Exhaust
★△1022	806039	1	Gasket-Rocker Cover
●1091	691516	1	Cap-Limiter
1095	808392	1	Gasket Set-Valve

Ref. No.	Part No.	Qty.	Description

△ Included in Valve Gasket Set-Ref. 1095.

★ Included in Engine Gasket Set-Ref. 358.

● Included in Carburetor Overhaul Kit-Ref. 121.







