



**Z350**

**Z-Master<sup>®</sup> with 122cm Mower and Bagger**

**Model No. 74804TE—Serial No. 220000001 and Up**

**Operator's Manual**



This spark ignition system complies with Canadian ICES-002.

Ce système d'allumage par étincelle de véhicule est conforme à la norme NMB-002 du Canada.

**Keep this Engine Owner's Manual with your unit. Should this Engine Owner's Manual become damaged or illegible, replace immediately. Replacements may be ordered through the engine manufacturer.**

# Contents

	<b>Page</b>
Introduction .....	3
Safety .....	3
Safe Operation Practices for Ride-on (riding) Rotary Lawnmower Machines .....	3
Safe Operating Practices .....	3
Toro Riding Mower Safety .....	5
Sound Pressure Level .....	5
Sound Power Level .....	5
Vibration Level .....	5
Slope Chart .....	7
Safety and Instruction Decals .....	9
Gasoline and Oil .....	13
Recommended Gasoline .....	13
Using Stabilizer/Conditioner .....	13
Filling the Fuel Tank .....	13
Check Engine Oil Level .....	13
Setup .....	14
Loose Parts .....	14
Removing the bracket from Rear Tail Wheel .....	14
Removing the Deck Banding .....	14
Checking the Tire Pressure .....	14
Activating the Battery .....	14
Removing the Machine from Crate .....	15
Checking the Hydraulic Fluid .....	15
Check Engine Oil Level .....	15
Operation .....	15
Think Safety First .....	15
Controls .....	15
Operating the Parking Brake .....	16
Starting and Stopping the Engine .....	16
Operating the Power Take Off (PTO) .....	17
The Safety Interlock System .....	17
Driving Forward or Backward .....	18
Stopping the Machine .....	19
Positioning the Seat .....	19
Adjusting the Height-of-Cut .....	19
Tilting the Mower .....	19
Dumping the Hopper .....	20

	<b>Page</b>
Pushing the Machine by Hand .....	21
Removing the Deck and Carrier Frame .....	21
Installing Deck and Carrier Frame .....	23
Install the Mulching Baffle .....	25
Operating with Mulching Baffle .....	25
Installing the Bagger and Discharge Baffles .....	26
Operating with Bagger .....	26
Installing and Removing the Plenum .....	27
Maintenance .....	28
Recommended Maintenance Schedule .....	28
Servicing the Cutting Blades .....	29
Correcting Cutting Unit Mismatch .....	31
Matching the Height-of-Cut .....	31
Checking the Front-to-Rear Pitch .....	31
Changing the Front-to-Rear Pitch .....	32
Checking the Side-to-Side Level .....	32
Change the Side-to-Side Level .....	32
Servicing the Air Cleaner .....	32
Servicing the Engine Oil .....	34
Servicing the Spark Plugs .....	35
Servicing the Fuel Filter .....	36
Servicing the Fuel Tank .....	37
Cleaning the Cooling Systems .....	37
Greasing and Lubricating .....	38
Servicing the Gearbox Fluid .....	39
Changing the Gearbox Fluid .....	39
Checking the Gearbox Fluid .....	39
Replacing the Castor Wheel Fork Bushings .....	39
Replacing Idler Arm Bushings .....	40
Replacing Push Arm Bushings .....	41
Servicing the Castor Wheels and Tail Wheel Bearings .....	42
Checking the Tire Pressure .....	42
Servicing the Hydraulic System .....	43
Adjusting the Motion Controls .....	45
Replacing the Power Take Off (PTO) Belt .....	45
Replacing the Traction Belt .....	46
Replacing the Blower Belt .....	46
Turning Engine Lift Hook .....	47
Servicing the Fuse .....	47
Servicing the Battery .....	47
Cleaning the Hopper Screens .....	50
Cleaning the Hopper Full Sensor .....	50
Wiring Diagram .....	51
Hydraulic Diagram .....	52
Cleaning and Storage .....	53
Troubleshooting .....	54

# Introduction

Read this manual carefully to learn how to operate and maintain your product properly. The information in this manual can help you and others avoid injury and product damage. Although Toro designs and produces safe products, you are responsible for operating the product properly and safely.

Whenever you need service, genuine Toro parts, or additional information, contact an Authorized Service Dealer or Toro Customer Service and have the model and serial numbers of your product ready. Figure 1 illustrates the location of the model and serial numbers on the product.

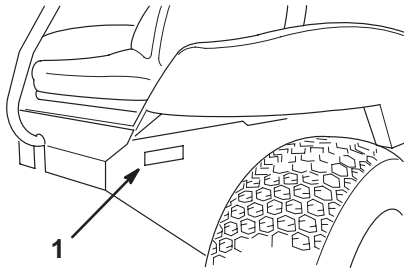

m-3220

Figure 1

1. Location of the model and serial numbers

Write the product model and serial numbers in the space below:

<b>Model No.</b> _____
<b>Serial No.</b> _____

This manual identifies potential hazards and has special safety messages that help you and others avoid personal injury and even death. **Danger**, **Warning**, and **Caution** are signal words used to identify the level of hazard. However, regardless of the hazard, be extremely careful.

**Danger** signals an extreme hazard that *will* cause serious injury or death if you do not follow the recommended precautions.

**Warning** signals a hazard that *may* cause serious injury or death if you do not follow the recommended precautions.

**Caution** signals a hazard that may cause minor or moderate injury if you do not follow the recommended precautions.

This manual uses two other words to highlight information. **Important** calls attention to special mechanical information and **Note**: emphasizes general information worthy of special attention.

# Safety

## Safe Operation Practices for Ride-on (riding) Rotary Lawnmower Machines

This machine meets or exceeds European Standards in effect at the time of production. However, improper use or maintenance by the operator or owner can result in injury. To reduce the potential for injury, comply with these safety instructions and always pay attention to the safety alert  symbol, which means CAUTION, WARNING, or DANGER—“personal safety instruction.” Failure to comply with the instruction may result in personal injury or death.

## Safe Operating Practices

The following instructions are from the CEN standard EN 836:1997.

This product is capable of amputating hands and feet and throwing objects. Always follow all safety instructions to avoid serious injury or death.

## Training

- Read the instructions carefully. Be familiar with the controls and the proper use of the equipment.
- Never allow children or people unfamiliar with these instructions to use the lawnmower. Local regulations can restrict the age of the operator.
- Never mow while people, especially children, or pets are nearby.
- Keep in mind that the operator or user is responsible for accidents or hazards occurring to other people or their property.
- Do not carry passengers.
- All drivers should seek and obtain professional and practical instruction. Such instruction should emphasize:
  - the need for care and concentration when working with ride-on machines;
  - control of a ride-on machine sliding on a slope will not be regained by the application of the brake. The main reasons for loss of control are:
    - insufficient wheel grip;
    - being driven too fast;
    - inadequate braking;
    - the type of machine is unsuitable for its task;

- lack of awareness of the effect of ground conditions, especially slopes;
- incorrect hitching and load distribution.

## Preparation

- While mowing, always wear substantial footwear and long trousers. Do not operate the equipment when barefoot or wearing open sandals.
- Thoroughly inspect the area where the equipment is to be used and remove all objects which may be thrown by the machine.
- **WARNING – Fuel is highly flammable.**
  - Store fuel in containers specifically designed for this purpose.
  - Refuel outdoors only and do not smoke while refuelling.
  - Add fuel before starting the engine. Never remove the cap of the fuel tank or add fuel while the engine is running or when the engine is hot.
  - If fuel is spilled, do not attempt to start the engine but move the machine away from the area of spillage and avoid creating any source of ignition until fuel vapors have dissipated.
  - Replace all fuel tanks and container caps securely.
- Replace faulty silencers.
- Before using, always visually inspect to see that the blades, blade bolts and cutter assembly are not worn or damaged. Replace worn or damaged blades and bolts in sets to preserve balance.
- On multi-bladed machines, take care as rotating one blade can cause other blades to rotate.

## Operation

- Do not operate the engine in a confined space where dangerous carbon monoxide fumes can collect.
- Mow only in daylight or in good artificial light.
- Before attempting to start the engine, disengage all blade attachment clutches and shift into neutral.
- Do not use on slopes of more than
  - 5° when mowing on side hills;
  - 15° when mowing uphill;
  - 10° when mowing downhill.
- Remember there is no such thing as a “safe” slope. Travel on grass slopes requires particular care. To guard against overturning:

- do not stop or start suddenly when going up or downhill;
- engage clutch slowly, always keep machine in gear, especially when travelling downhill;
- machine speeds should be kept low on slopes and during tight turns;
- stay alert for humps and hollows and other hidden hazards;
- never mow across the face of the slope, unless the lawnmower is designed for this purpose.
- Use care when pulling loads or using heavy equipment.
  - Use only approved drawbar hitch points.
  - Limit loads to those you can safely control.
  - Do not turn sharply. Use care when reversing.
  - Use counterweight(s) or wheel weights when suggested in the instruction handbook.
- Watch out for traffic when crossing or near roadways.
- Stop the blades rotating before crossing surfaces other than grass.
- When using any attachments, never direct discharge of material toward bystanders nor allow anyone near the machine while in operation.
- Never operate the machine with defective guards or without safety protective devices in place.
- Do not change the engine governor settings or overspeed the engine. Operating the engine at excessive speed can increase the hazard of personal injury.
- Before leaving the operator’s position:
  - disengage the power take-off and lower the attachments;
  - change into neutral and set the parking brake;
  - stop the engine and remove the key.
- Disengage drive to attachments, stop the engine, and disconnect the spark plug wire(s) or remove the ignition key
  - before clearing blockages or unclogging chute;
  - before checking, cleaning or working on the lawnmower;
  - after striking a foreign object. Inspect the lawnmower for damage and make repairs before restarting and operating the equipment;
  - if the machine starts to vibrate abnormally (check immediately).
- Disengage drive to attachments when transporting or not in use.

- Stop the engine and disengage drive to attachment
  - before refuelling;
  - before removing the grass catcher;
  - before making height adjustment unless adjustment can be made from the operator's position.
- Reduce the throttle setting during engine run-out and, if the engine is provided with a shut-off valve, turn the fuel off at the conclusion of mowing.

## Maintenance and Storage

- Keep all nuts, bolts and screws tight to be sure the equipment is in safe working condition.
- Never store the equipment with fuel in the tank inside a building where fumes can reach an open flame or spark.
- Allow the engine to cool before storing in any enclosure.
- To reduce the fire hazard, keep the engine, silencer, battery compartment and fuel storage area free of grass, leaves, or excessive grease.
- Check the grass catcher frequently for wear or deterioration.
- Replace worn or damaged parts for safety.
- If the fuel tank has to be drained, this should be done outdoors.
- On multi-bladed machines, take care as rotating one blade can cause other blades to rotate.
- When machine is to be parked, stored or left unattended, lower the cutting means unless a positive mechanical lock is used.

## Toro Riding Mower Safety

The following list contains safety information specific to Toro products or other safety information that you must know that is not included in the CEN standard.

- Use only Toro-approved attachments. Warranty may be voided if used with unapproved attachments.

## Sound Pressure Level

This unit has an equivalent continuous A-weighted sound pressure at the operator ear of: 90 dB(A), based on measurements of identical machines per procedures outlined in Directive 84/538/EEC and amendments.

## Sound Power Level

This unit has a sound power level of: 105 Lwa, based on measurements of identical machines per procedures outlined in Directive 84/538/EEC and amendments.

## Vibration Level

This unit has a maximum hand-arm vibration level of 2.0 m/s<sup>2</sup> and whole body vibration level of 1.2 m/s<sup>2</sup>, based on measurements of identical machines per EN 1033 and EN 1032.



# Slope Chart





# Safety and Instruction Decals



Safety decals and instructions are easily visible to the operator and are located near any area of potential danger. Replace any decal that is damaged or lost.

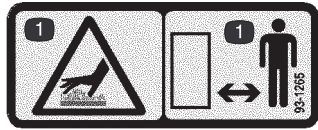

**93-1265**

1. Hot surface/burn hazard—stay a safe distance from the hot surface.



**100-3613**

1. Full body entanglement hazard—stay away from moving parts

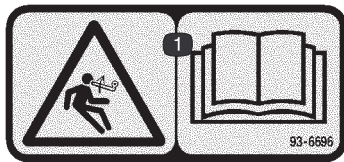

**93-6696**

1. Stored energy hazard—read the *Operator's Manual*.



**100-3952**

1. Hydraulic oil level
2. Hot surface/burn hazard—stay a safe distance from the hot surface

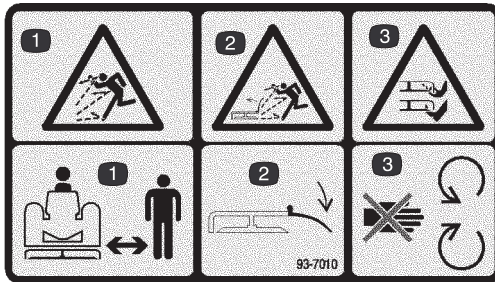

**93-7010**

1. Thrown object hazard—stay a safe distance from the machine.
2. Thrown object hazard, mower—keep the deflector in place.
3. Cutting/dismemberment of hand or foot—stay away from moving parts.

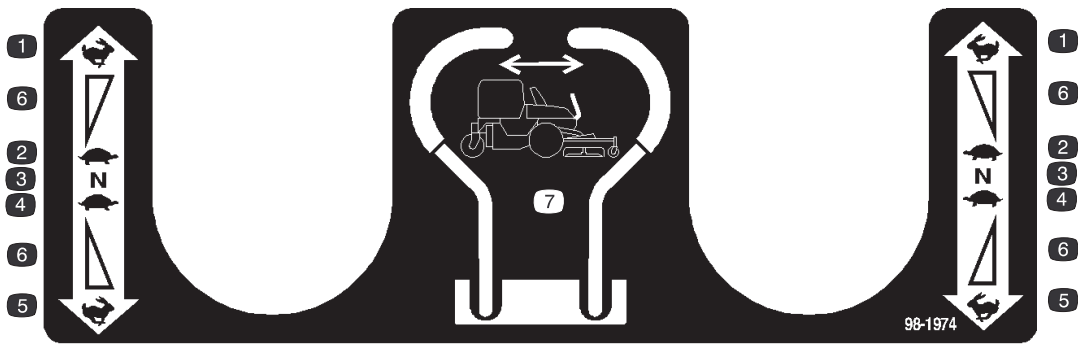

98-1974

- 1. Fast forward
- 2. Slow forward
- 3. Neutral
- 4. Slow reverse
- 5. Fast reverse
- 6. Continuous variable setting
- 7. Speed/direction controls



98-1975

- 1. Hot surface/burn hazard—stay a safe distance from the hot surface.

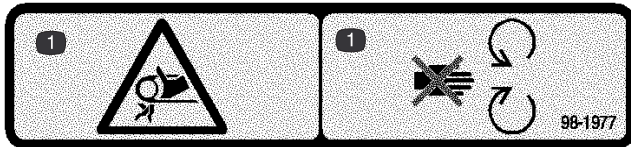

98-1977

- 1. Entanglement hazard, belt—stay away from moving parts.

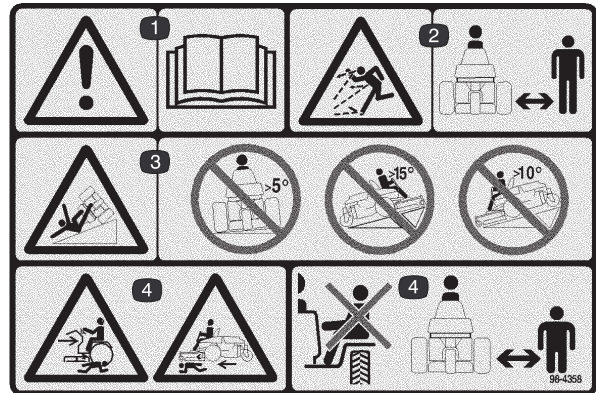

98-4358

- 1. Warning—read the *Operator's Manual*.
- 2. Thrown object hazard—stay a safe distance from the machine.
- 3. Tipping hazard—do not drive the machine across a slope greater than 5 degrees, up a slope greater than 15 degrees, or down a slope greater than 10 degrees.
- 4. Crushing/dismemberment hazard of bystanders while backing—do not carry passengers and keep children a safe distance from the machine.

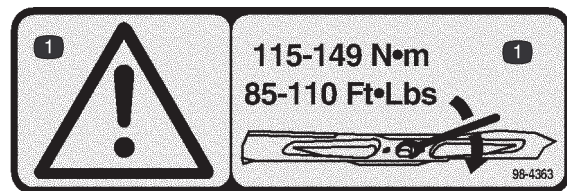

98-4363

- 1. Warning—torque the blade bolt/nut to 115–149 N·m (85–110ft.-lb.).

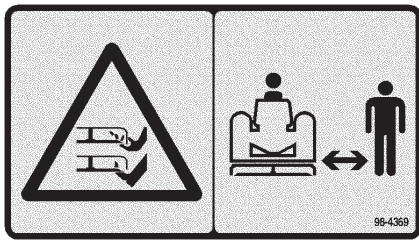

98-4369

1. Cutting/dismemberment hazard of hand or foot, mower blade—stay a safe distance from the machine.



98-4387

1. Warning—wear hearing protection.

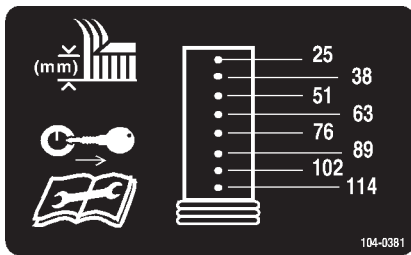

104-0381

1. Height of cut in millimeters
2. Remove the ignition key and read the instructions before servicing or performing maintenance.

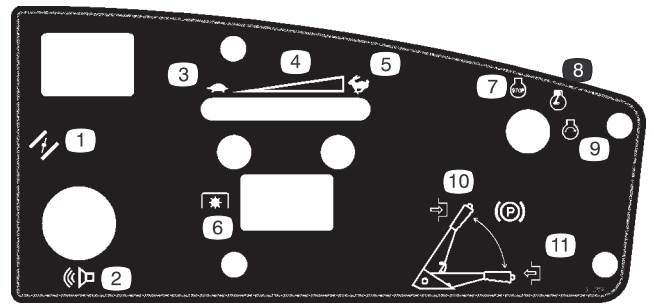

104-7808

- |                                |                                  |
|--------------------------------|----------------------------------|
| 1. Choke                       | 7. Engine—stop                   |
| 2. Horn                        | 8. Engine—run                    |
| 3. Slow                        | 9. Engine—start                  |
| 4. Continuous variable setting | 10. Engage the parking brake     |
| 5. Fast                        | 11. Disengage the parking brake. |
| 6. Power take-off (PTO)        |                                  |

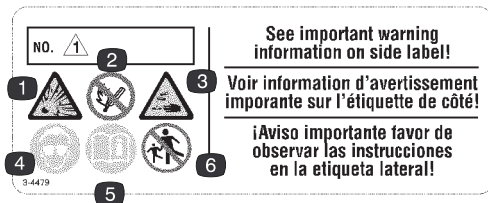

104-4163

- |                                        |                                                      |
|----------------------------------------|------------------------------------------------------|
| 1. Explosion hazard                    | 4. Wear eye protection                               |
| 2. No fire, open flames, or smoking.   | 5. Read the <i>Operator's Manual</i> .               |
| 3. Caustic liquid/chemical burn hazard | 6. Keep bystanders a safe distance from the battery. |

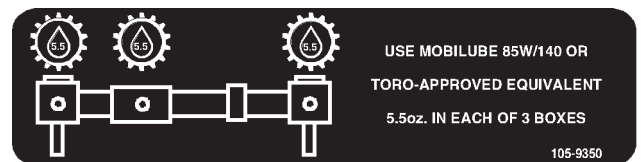

105-9350

MAINTENANCE FREE • SANS ENTRETIEN • LIBRE DE MANTENIMIENTO

NIVEAU MAXIMUM      MAXIMUM FILL      CAPACIDAD MAXIMA  
 NIVEAU MINIMUM      MINIMUM FILL      CAPACIDAD MINIMA

**7**      **8**

**⚠ DANGER/POISON ¡PELIGRO/VENENO!**

**1**

**2**

**Pb**

RECYCLE • RECYCLAGE • RECICLAR

S-4015

<p><b>3</b></p> <p><b>SHIELD EYES.</b> EXPLOSIVE GASES CAN CAUSE BLINDNESS OR INJURY.</p> <p><b>PROTÉGER LES YEUX.</b> GAZ EXPLOSIFS PEUVENT RENDRE AVEUGLE OU PROVOQUER DES LÉSIONS.</p> <p><b>PROTEJA LOS OJOS.</b> GASES EXPLOSIVOS PUEDEN CAUSAR CEGUERA O DAÑO.</p>	<p><b>4</b></p> <p><b>NO</b> • SPARKS • FLAMES • SMOKING</p> <p><b>ÉLOIGNER</b> • ÉTINCELLES • FLAMMES • CIGARETTES</p> <p><b>NO</b> • CHISPAS • FLAMAS • FUMAR</p>	<p><b>5</b></p> <p><b>SULFURIC ACID</b> CAN CAUSE BLINDNESS OR SEVERE BURNS.</p> <p><b>ACIDE SULFURIQUE</b> PEUT RENDRE AVEUGLE OU PROVOQUER DES BRULURES GRAVES.</p> <p><b>ACIDO SULFURICO</b> PUEDE CAUSAR CEGUERA O QUEMADURAS SEVERAS.</p>	<p><b>6</b></p> <p><b>FLUSH EYES IMMEDIATELY WITH WATER. GET MEDICAL HELP FAST.</b></p> <p><b>RINCER IMMEDIATEMENT LES YEUX A GRANDE EAU. CONTACTER RAPIDEMENT UN MEMBRE DE LA PROFESSION MEDICALE.</b></p> <p><b>LAVE LOS OJOS DE INMEDIATO. CONSIGA AYUDA MEDICA RAPIDO.</b></p>
--------------------------------------------------------------------------------------------------------------------------------------------------------------------------------------------------------------------------------------------------------------------------------------	---------------------------------------------------------------------------------------------------------------------------------------------------------------------------------------------------------	------------------------------------------------------------------------------------------------------------------------------------------------------------------------------------------------------------------------------------------------------------	------------------------------------------------------------------------------------------------------------------------------------------------------------------------------------------------------------------------------------------------------------------------------------

**KEEP OUT OF THE REACH OF CHILDREN. DO NOT TIP. DO NOT OPEN BATTERY!**  
**MAINTENIR HORS DE LA PORTÉE DES ENFANTS. NE RENVERSEZ PAS. N'OUVREZ PAS LA BATTERIE!**  
**MANTENGASE FUERA DEL ALCANCE DE LOS NIÑOS. NO INCLINE. NO ABRA LA BATERIA!**

**9**

**HOW TO ACTIVATE DRY CHARGED BATTERIES**

- Use only battery electrolyte (1.265 Sp.Gr.) to fill battery initially.
- Do not overfill. Let stand for 15 minutes.
- Charge battery at 4-5 amps until specific gravity is 1.250 or higher and temperature is at least 60°F. – all cells gassing freely.
- After battery has been activated, add only water to replace normal loss.

Dist. by: /por: /par: EPM Products, Baltimore, MD 21226      MADE IN U.S.A. • FABRIQUE AUX É.U.A. • HECHO EN E.U.A.

**104-5091**

- |                                                                                                                                                                                        |                                                                                                                                            |                                                                                                                                           |
|----------------------------------------------------------------------------------------------------------------------------------------------------------------------------------------|--------------------------------------------------------------------------------------------------------------------------------------------|-------------------------------------------------------------------------------------------------------------------------------------------|
| <ol style="list-style-type: none"> <li>Contains lead; do not discard.</li> <li>Recycle</li> <li>Wear eye protection; explosive gases can cause blindness and other injuries</li> </ol> | <ol style="list-style-type: none"> <li>No sparks, flame, or smoking</li> <li>Sulfuric acid can cause blindness or severe burns.</li> </ol> | <ol style="list-style-type: none"> <li>Flush eyes immediately with water and get medical help fast.</li> <li>Maximum fill line</li> </ol> |
| <ol style="list-style-type: none"> <li>Minimum fill line</li> <li>Instructions for activating the battery</li> </ol>                                                                   |                                                                                                                                            |                                                                                                                                           |

# Gasoline and Oil

## Recommended Gasoline

Use UNLEADED Regular Gasoline suitable for automotive use (85 pump octane minimum). Leaded regular gasoline may be used if unleaded regular is not available.

**Important** Never use methanol, gasoline containing methanol, or gasohol containing more than 10% ethanol because the fuel system could be damaged. Do not mix oil with gasoline.



### Danger



**In certain conditions, gasoline is extremely flammable and highly explosive. A fire or explosion from gasoline can burn you and others and can damage property.**

- **Fill the fuel tank outdoors, in an open area, when the engine is cold. Wipe up any gasoline that spills.**
- **Never fill the fuel tank inside an enclosed trailer.**
- **Do not fill the fuel tank completely full. Add gasoline to the fuel tank until the level is 1/4 to 1/2 inch (6 to 13 mm) below the bottom of the filler neck. This empty space in the tank allows gasoline to expand.**
- **Never smoke when handling gasoline, and stay away from an open flame or where gasoline fumes may be ignited by a spark.**
- **Store gasoline in an approved container and keep it out of the reach of children. Never buy more than a 30-day supply of gasoline.**
- **Always place gasoline containers on the ground away from your vehicle before filling.**
- **Do not fill gasoline containers inside a vehicle or on a truck or trailer bed because interior carpets or plastic truck bed liners may insulate the container and slow the loss of any static charge.**
- **When practical, remove gas-powered equipment from the truck or trailer and refuel the equipment with its wheels on the ground.**
- **If this is not possible, then refuel such equipment on a truck or trailer from a portable container, rather than from a gasoline dispenser nozzle.**
- **If a gasoline dispenser nozzle must be used, keep the nozzle in contact with the rim of the fuel tank or container opening at all times until fueling is complete.**



### Warning



**Gasoline is harmful or fatal if swallowed. Long-term exposure to vapors can cause serious injury and illness.**

- **Avoid prolonged breathing of vapors.**
- **Keep your face away from the nozzle and gas tank or conditioner opening.**
- **Keep gas away from eyes and skin.**

## Using Stabilizer/Conditioner

Use a fuel stabilizer/conditioner in the machine to provide the following benefits:

- Keeps gasoline fresh during storage of 90 days or less. For longer storage it is recommended that the fuel tank be drained.
- Cleans the engine while it runs
- Eliminates gum-like varnish buildup in the fuel system, which causes hard starting

**Important** Do not use fuel additives containing methanol or ethanol.

Add the correct amount of gas stabilizer/conditioner to the gas.

**Note:** A fuel stabilizer/conditioner is most effective when mixed with fresh gasoline. To minimize the chance of varnish deposits in the fuel system, use fuel stabilizer at all times.

## Filling the Fuel Tank

1. Shut the engine off and set the parking brake.
2. Clean around fuel tank cap and remove the cap. Add unleaded regular gasoline to fuel tank, until the level is 6 to 13 mm (1/4 to 1/2 inch) below the bottom of the filler neck. This space in the tank allows gasoline to expand. Do not fill the fuel tank completely full.
3. Install fuel tank cap securely. Wipe up any gasoline that may have spilled.

## Check Engine Oil Level

Before you start the engine and use the machine, check the oil level in the engine crankcase; refer to Checking Oil Level, page 34.

# Setup

**Note:** Determine the left and right sides of the machine from the normal operating position.

## Loose Parts

**Note:** Use the chart below to verify all parts have been shipped.

Description	Qty.	Use
Mulching baffle	1	For mulching mode
Key	2	Use in the ignition
Safety booklet	1	Read before operating the machine.
Operator's manual	1	
Engine operator's manual	1	
Parts catalog	1	
Registration card	1	Fill out and return to Toro.

## Removing the bracket from Rear Tail Wheel

1. Remove locknut from bolt that fastens crate bracket to tail wheel (Fig. 2).
2. Remove crate bracket from wheel bolt. Install locknut on to bolt until fork clamps onto spacer (Fig. 2).

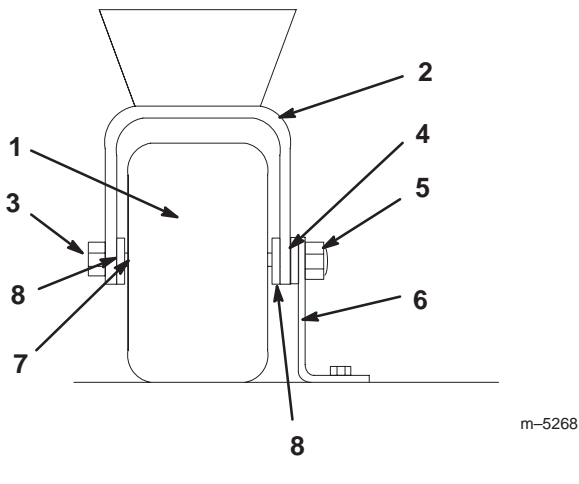

**Figure 2**

- |               |                  |
|---------------|------------------|
| 1. Tail wheel | 5. Locknut       |
| 2. Fork       | 6. Crate bracket |
| 3. Bolt head  | 7. Spacer        |
| 4. Washer     | 8. Shim Washers  |

## Removing the Deck Banding

Remove any tie down banding that holds deck in place.

## Checking the Tire Pressure

Check the air pressure in all tires; refer to Tire Pressure, page 42.

## Activating the Battery

Bulk electrolyte with 1.265 specific gravity must be purchased from a local battery supply outlet.

⚠
Danger
⚠

**Battery electrolyte contains sulfuric acid which is a deadly poison and causes severe burns.**

- Do not drink electrolyte and avoid contact with skin, eyes or clothing. Wear safety glasses to shield your eyes and rubber gloves to protect your hands.**
- Fill the battery where clean water is always available for flushing the skin.**
- Follow all instructions and comply with all safety messages on the electrolyte container.**

1. Remove the battery from the machine. Refer to Removing the Battery on page 49.

2. Clean the top of the battery with a paper towel.

**Note:** Never fill the battery with electrolyte while the battery is installed in the machine. Electrolyte could be spilled on other parts and cause corrosion.

3. Remove the vent caps from the battery (Fig. 3).

- Slowly pour electrolyte into each battery cell until the level is up to the **upper** line (Fig. 3) on the battery case.

**Important** Do not overfill the battery because electrolyte (sulfuric acid) can cause severe corrosion and damage to the chassis.

- Wait five to ten minutes after filling the battery cells. Add electrolyte, if necessary, until the electrolyte level is up to the **upper** line (Fig. 3) on the battery case.
- Reinstall battery filler caps.

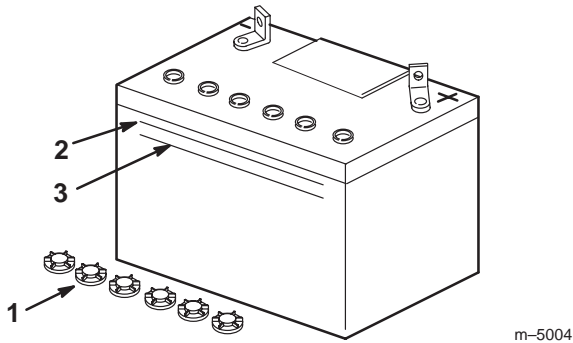

**Figure 3**

- Filler caps
- Upper** line
- Lower** line

**Warning**

Charging battery produces gasses that can explode and cause serious injury.

- Keep cigarettes, sparks and flames away from battery.
- Make sure the ignition switch is off.
- Ventilate when charging or using battery in an enclosed space.

- Charge the battery. Refer to Charging the Battery on page 49.
- Install the battery into the machine. Refer to Installing the Battery on page 48.

**Note:** Do not run the machine with the battery disconnected, electrical damage may occur.

## Removing the Machine from Crate

- Tilt deck down and latch into position.
- Machine can now be driven forward off crate.

## Checking the Hydraulic Fluid

Check the hydraulic fluid level before the engine is first started.

Refer to Checking the Hydraulic Fluid on page 43.

## Check Engine Oil Level

Before you start the engine and use the machine, check the oil level in the engine crankcase; refer to Checking the Engine Oil Level, page 34.

## Operation

**Note:** Determine the left and right sides of the machine from the normal operating position.

## Think Safety First

Carefully read all the safety instructions and decals in the safety section. Knowing this information could help you, your family, pets or bystanders avoid injury.

The use of protective equipment for eyes, hearing, feet, and head is recommended.

**Caution**

This machine produces sound levels in excess of 85 dBA at the operators ear and can cause hearing loss through extended periods of exposure.

Wear hearing protection when operating this machine.

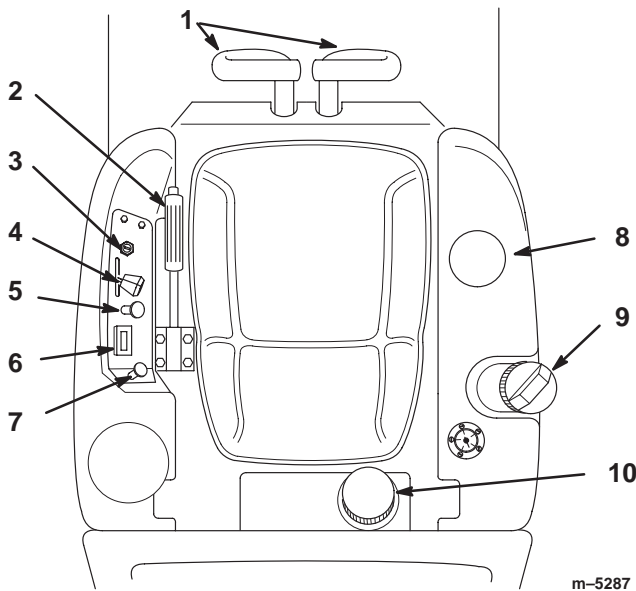

**Figure 4**

- Caution
- Wear hearing protection

## Controls

Become familiar with all the controls before you start the engine and operate the machine (Fig. 5).

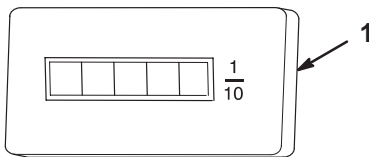

**Figure 5**

- |                         |                         |
|-------------------------|-------------------------|
| 1. Motion control lever | 6. Hourmeter            |
| 2. Parking brake        | 7. Choke                |
| 3. Ignition switch      | 8. Drink holder         |
| 4. Throttle             | 9. Fuel cap             |
| 5. Power take off (PTO) | 10. Hydro reservoir cap |

## Hour Meter

The hour meter records the number of hours the engine has operated. It operates when the engine is running. Use these times for scheduling regular maintenance.



**Figure 6**

1. Hour meter

## Operating the Parking Brake

Always set the parking brake when you stop the machine or leave it unattended.

### Setting the Parking Brake

1. Move the motion control levers to neutral (Fig. 5).
2. Pull up on the parking brake lever to set the parking brake (Fig. 7). The parking brake lever should stay firmly in the set position.

### Releasing the Parking Brake

1. Push in on the button and lower parking brake lever to off (Fig. 7).

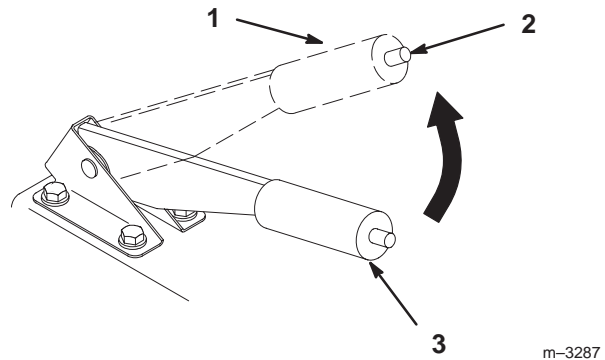

**Figure 7**

- |                      |                      |
|----------------------|----------------------|
| 1. Parking brake—Set | 3. Parking brake—Off |
| 2. Button            |                      |

## Starting and Stopping the Engine

### Starting the Engine

1. Sit down on the seat and set the parking brake; refer to Setting the Parking Brake, page 16.
2. Move the motion control levers to neutral.
3. Move the PTO (power take off) switch to off (Fig. 8).
4. Move the throttle control midway between slow and fast positions before starting a cold engine.
5. Move the choke control to the on position before starting a cold engine.

**Note:** A warm or hot engine may not require choking. After engine starts, move choke control to the off position.

6. Turn ignition key to the start position to energize starter. When engine starts, release key.

**Note:** If starter does not crank, move the motion control levers slightly forward or backward to locate neutral.

**Important** Do not engage starter for more than 10 seconds at a time. If engine fails to start allow 30 second cool-down period between attempts. Failure to follow these instructions can burn out starter motor.

7. After the engine starts, gradually move the choke to the off position (Fig. 9). If the engine stalls or hesitates, move the choke back to the on position for a few seconds. Then move the throttle lever to desired setting. Repeat this as required.

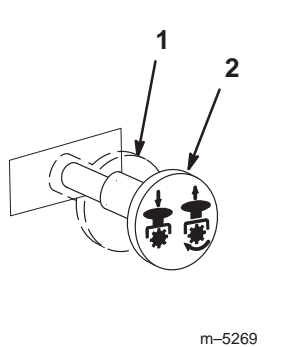

**Figure 8**

1. PTO-Off
2. PTO-On

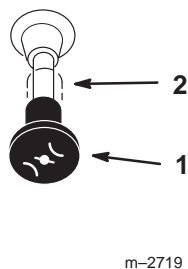

**Figure 9**

1. Choke-On
2. Choke-Off

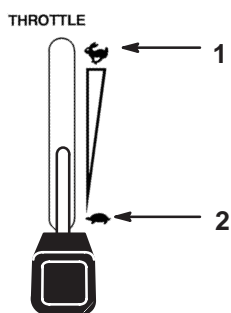

**Figure 10**

1. Fast
2. Slow

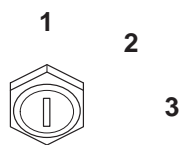

**Figure 11**

1. Off
2. Run
3. Start

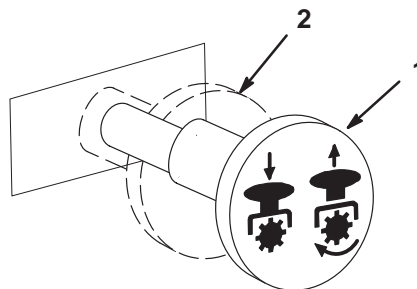

**Figure 12**

1. On-Engaged
2. Off-Disengaged

**Important** Make sure fuel shut off valve is closed before transporting or storing machine, as fuel leakage may occur.

## Operating the Power Take Off (PTO)

The power take off (PTO) switch engages and disengages power to the attachment clutch (mower blades).

### Engaging the Power Take Off (PTO)

1. With engine running, move motion control levers to neutral to stop the machine.
2. To prevent engine stalling, from heavy load, move throttle to the fast position.
3. Pull the power take off (PTO) switch to the on position to engage (Fig. 12).

## Stopping the Engine

1. Move the throttle lever to slow (Fig. 10).
2. Set the parking brake.
3. Turn the ignition key to off (Fig. 11).

**Note:** If the engine has been working hard or is hot, let it idle for a minute before turning the ignition key off. This helps cool the engine before it is stopped. In an emergency, the engine may be stopped by turning the ignition key to off immediately.

4. Pull wire off spark plug(s) to prevent possibility of accidental starting before transporting or storing machine.
5. Close fuel shut off valve under fuel tank before transporting or storing machine.

## Disengaging the Power Take Off (PTO)

1. Push the power take off (PTO) switch in. This moves the switch to the off position to disengage (Fig. 12).

## The Safety Interlock System



### Caution



If safety interlock switches are disconnected or damaged the machine could operate unexpectedly causing personal injury.

- Do not tamper with the interlock switches.
- Check the operation of the interlock switches daily and replace any damaged switches before operating the machine.

## Understanding the Safety Interlock System

The safety interlock system is designed to prevent the engine from starting unless:

- The parking brake is set.
- The power take off (PTO) is disengaged or off.
- The motion control levers are in neutral position.

The safety interlock system also is designed to stop the engine when:

- The motion control levers are moved out of neutral with the parking brake is set.
- You rise from the seat when the power take off (PTO) is on or the motion control levers are not in neutral
- The motion control levers are moved out of neutral or PTO is engaged with the hopper tilted up

## Testing the Safety Interlock System

Test the safety interlock system before you use the machine each time. If the safety system does not operate as described below, have an Authorized Service Dealer repair the safety system immediately.

1. Set the parking brake and move power take off (PTO) to on. Try starting the engine; the engine should not crank.
2. Set the parking brake and move power take off (PTO) to off. Move one then the other motion control lever forward or reverse. Try starting the engine; the engine should not crank.
3. Set the parking brake, move power take off (PTO) to off and hold the motion control levers in neutral. Now start the engine. While the engine is running engage the power take off (PTO) and rise slightly from the seat; the engine should stop.
4. Set the parking brake, move power take off (PTO) to off and hold the motion control levers in neutral. Now start the engine. While the engine is running, move the motion control levers forward or reverse; the engine should stop.
5. Tilt the hopper up, set the parking brake, move power take off (PTO) to off and hold the motion control levers in neutral. Now start the engine. While the engine is running, move the motion control levers forward or reverse; the engine should stop.

## Driving Forward or Backward

The throttle control regulates the engine speed as measured in rpm (revolutions per minute). Place the throttle control in the fast position for best attachment performance. Always operate in the full throttle position when operating attachments.

### Driving Forward

1. Release the parking brake; refer to Setting the Parking Brake, page 16.
2. To go forward, slowly push the motion control levers forward (Fig. 13).

**Note:** Engine will kill if motion control levers are moved with parking brake engaged.

To go straight, move both motion control levers the same distance (Fig. 13).

To turn move the motion control lever toward neutral, on the side you want to turn toward (Fig. 13).

The farther you move the motion control levers in either direction, the faster the machine will move in that direction.

To slow or stop move the motion control levers to neutral.

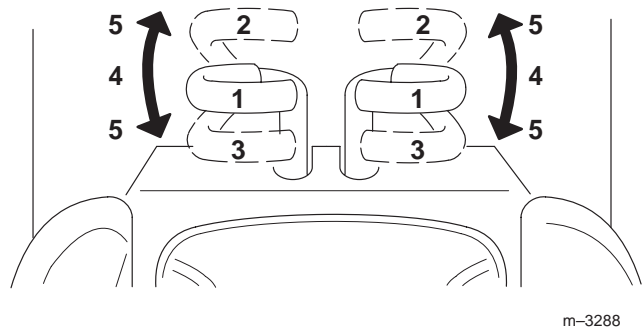

**Figure 13**

- |                                          |             |
|------------------------------------------|-------------|
| 1. Motion control lever-neutral position | 3. Backward |
| 2. Forward                               | 4. Slow     |
|                                          | 5. Fast     |

### Driving Backward

1. Release the parking brake; refer to Setting the Parking Brake, page 16.
2. To go backward, slowly pull the motion control levers rearward (Fig. 13).

To go straight, move both motion control levers the same distance (Fig. 13).

To turn move the motion control lever toward neutral, on the side you want to turn toward (Fig. 13).

To slow or stop move the motion control levers to neutral.

## Stopping the Machine

To stop the machine, move the motion control levers to neutral, disengage the power take off (PTO), and turn the ignition key to off. Also set the parking brake when you leave the machine; refer to Setting the Parking Brake, page 16. Remember to remove the key from the ignition switch.

⚠
Caution
⚠

**Children or bystanders may be injured if they move or attempt to operate the tractor while it is unattended.**

**Always remove the ignition key and set the parking brake when leaving the machine unattended, even if just for a few minutes.**

## Positioning the Seat

The seat can move forward and backward. Position the seat where you have the best control of the machine and are most comfortable.

1. To adjust, remove the locknut and washer, and tip seat forward (Fig. 14).

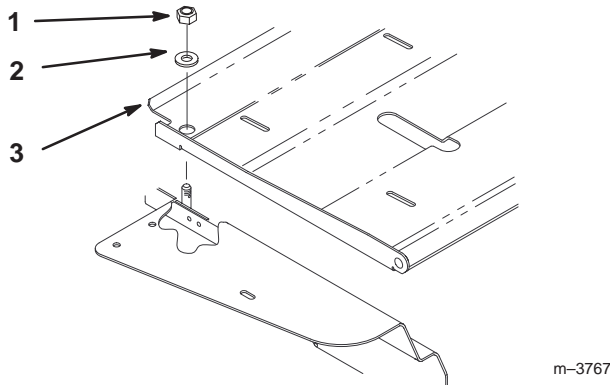

**Figure 14**

1. Locknut
2. Washer
3. Seat base

2. Loosen the seat mounting bolts slide seat to the desired position in the adjusting slots and tighten the mounting bolts (Fig. 15).
3. Lower seat and secure with washer and locknut (Fig. 14).

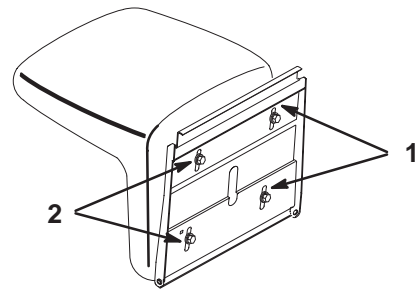

**Figure 15**

1. Adjustment slot
2. Mounting bolt

m-3280

## Adjusting the Height-of-Cut

The height-of-cut can be adjusted from 1 to 4-1/2 inches (25 to 115 mm) in 1/2 inch (13 mm) increments by relocating four hairpin cotter pins in different hole locations.

**Note:** Fine adjustment can be done by removing washers.

1. To adjust, remove hairpin cotter from height-of-cut post (Fig. 16).
2. Select hole in height-of-cut post corresponding to the height-of-cut desired. Lift on side of deck to align holes and insert hairpin cotter (Fig. 16).

**Important** All four hairpin cotter pins must be in the same hole location for a level cut.

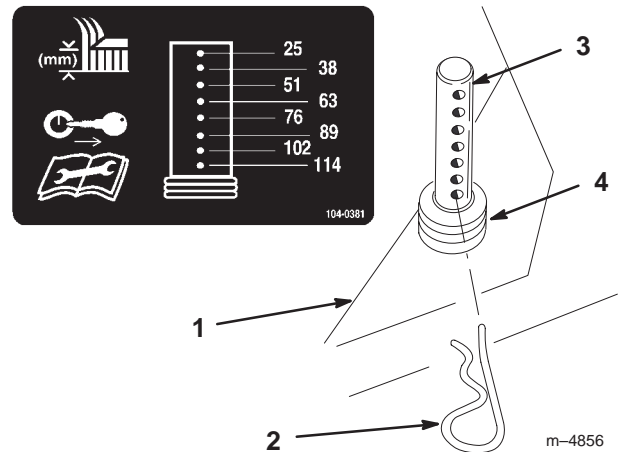

**Figure 16**

1. Carrier Frame
2. Hairpin Cotter
3. Height-of-Cut Post
4. Washers

## Tilting the Mower

The mower can be tilted up for ease of service or to shorten unit length for transport and storage.



## Caution



The mower deck is heavy and could injure someone while raising or lowering the deck.

- Use caution when raising or lowering deck.

### Raising the Mower

1. Disengage the power take off (PTO), set the parking brake, and turn the ignition key to off. Remove spark plug wire(s) and remove the key.
2. Lift on side of carrier frame near latch to release weight on latch pin.
3. Pull out on latch pin to release and rotate into notch to hold in the unlocked position (Fig. 17). Repeat on the other side.
4. Rotate latch pins into released position after deck has been lowered onto rear rollers.

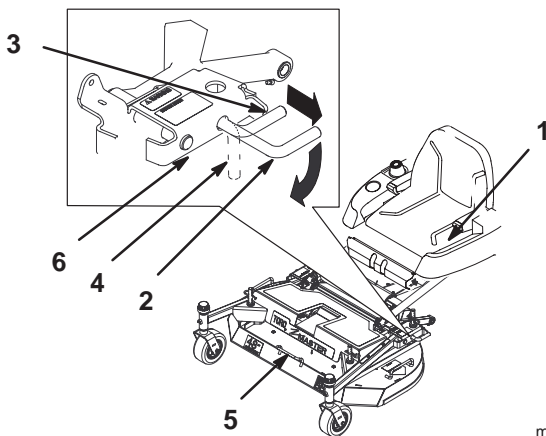

m-4864

Figure 17

- |                      |                               |
|----------------------|-------------------------------|
| 1. Parking brake     | 4. Locked Position            |
| 2. Latch pin         | 5. Deck Handle                |
| 3. Unlocked Position | 6. Lift here – after lowering |
5. Standing in front of the mower, lift up on deck handle and push rearward on front to raise mower (Fig. 18).
  6. Raise mower until it contacts stops and latch pins snap into locked position.

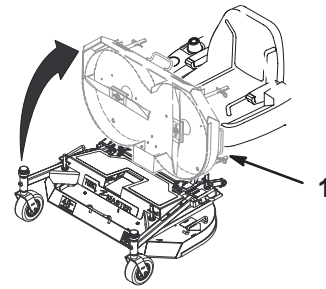

m-4863

Figure 18

1. Mower up

### Lowering the Mower

1. Pull out latch pins and rotate into notch to hold in the unlocked position (Fig. 17).
2. Standing in front of the mower, pull front deck handle forward and lower mower (Fig. 18).
3. Rotate latch pins into released position and lift on side of carrier frame near latch pin until latch pin engages (Fig. 17). Repeat on the other side.

### Dumping the Hopper

The hopper is equipped with a sensor that checks for a full condition. When the alarm buzzer sounds the PTO must be moved to the off position immediately and the hopper needs to be emptied.

**Important** The hopper is interlocked with the PTO and the engine will stop if these steps are not followed before dumping the hopper or getting out of the seat.

1. Locate the traction unit so the hopper door is located where you want to dump the clippings.
2. Ensure that the power take off (PTO) switch is off, move the traction controls to neutral and set the parking brake.
3. Unhook the rear door latch (Fig. 19).
4. Unhook the front latch on hopper (Fig. 19).
5. Lift up on the hopper in the lower front and dump the clippings (Fig. 19).

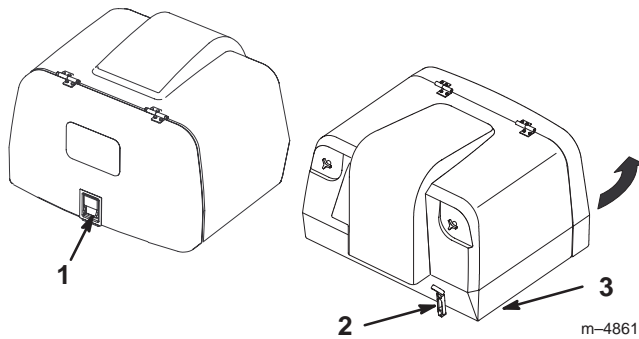

**Figure 19**

1. Rear Door latch
2. Front Hopper latch
3. Lift here

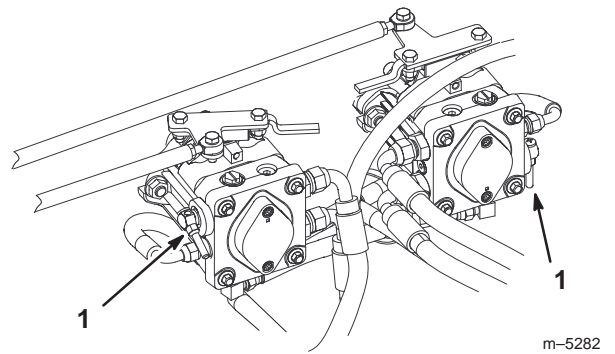

**Figure 20**

1. By-pass valve

6. Lower the hopper. Firmly secure the hopper door so it latches and secure the front hopper latch (Fig. 19).

**Important** Front hopper latch must be secured to prevent hopper from accidentally tilting during transport. Ensure the hopper door latch is fully closed.

## Pushing the Machine by Hand

**Important** Always push the machine by hand. Never tow the machine because hydraulic damage may occur.

### Pushing the Machine

1. Disengage the power take off (PTO) and turn the ignition key to off.
2. Rotate pump by-pass valves counterclockwise 2 turns. This allows hydraulic fluid to by-pass the pump enabling the wheels to turn freely (Fig. 20).

**Important** Rotate by-pass valve a maximum of 2 turns so the valve does not come out of the body causing fluid to run out.

3. Release the parking brake.
4. Push the machine.

### Operating the Machine

1. Turn the by-pass valves clockwise until they are tight. Do not over tighten (Fig. 20).

**Note:** The machine will not drive unless by-pass valves are turned in completely.

## Removing the Deck and Carrier Frame

1. Disengage the power take off (PTO), set the parking brake, and turn the ignition key to off. Remove the key.
2. Lifting slightly on the deck handles, remove hairpin cotters from the height-of-cut posts and separate mower from carrier frame (Fig. 21).

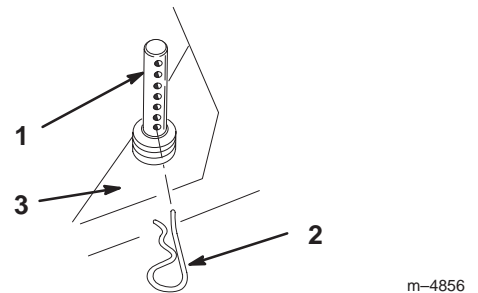

**Figure 21**

1. Height-of-cut post
2. Hairpin Cotter
3. Carrier Frame

3. Remove plenum from traction unit. Refer to Installing and Removing the Plenum on page 27.
4. Raise seat, to gain access to plenum cable. Remove washer and nut from plenum cable end (Fig. 22).

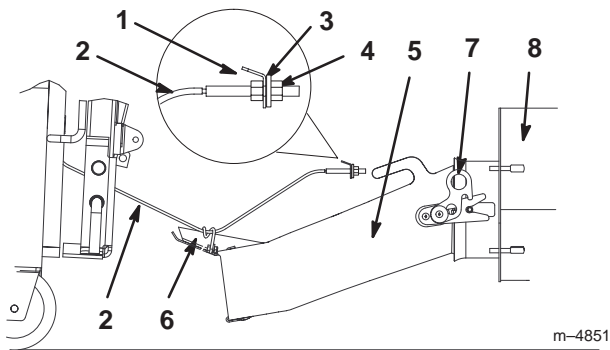

**Figure 22**

- |                 |                       |
|-----------------|-----------------------|
| 1. Bracket      | 5. Plenum             |
| 2. Plenum Cable | 6. Plenum cable guide |
| 3. Washer       | 7. Plenum Latches     |
| 4. Nut          | 8. Blower Housing     |

5. Tilt carrier frame into its upright position. Refer to Tilting the Mower on page 19.
6. Place a block, approximately 4 inches high, under the carrier frame. This will raise the frame vertically.
7. Check to see if tension has been removed from the spring assemblies. If tension remains add blocks to raise carrier frame higher. If there is too much tension use a smaller block (Fig. 23).
8. Remove shoulder bolts (3/8 x 7/8 inch) and locknuts (3/8 inch) securing spring end plate assemblies to carrier frame (Fig. 23).

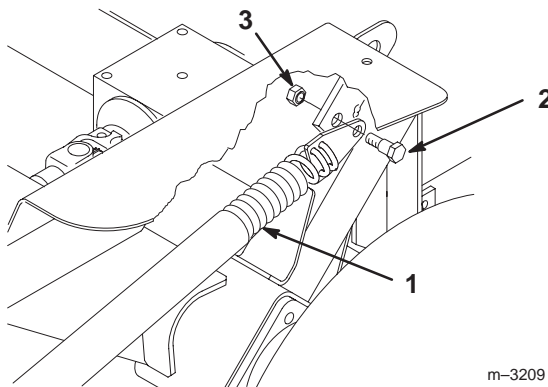

**Figure 23**

- |                                  |                      |
|----------------------------------|----------------------|
| 1. Spring Assembly               | 3. Locknut, 3/8 inch |
| 2. Shoulder Bolt, 3/8 x 7/8 inch |                      |

9. Remove the block under the carrier frame.

10. Tilt carrier frame down.

11. Remove the two nuts and bolts that hold the bar for rubber guard. The bar is under the motion control levers. Fold the rubber guard onto the footrest (Fig. 24).

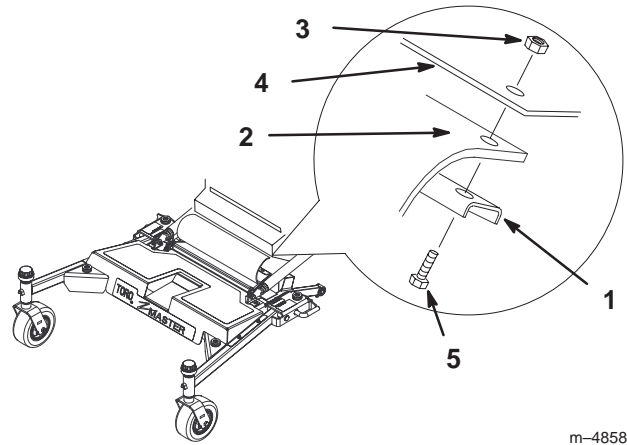
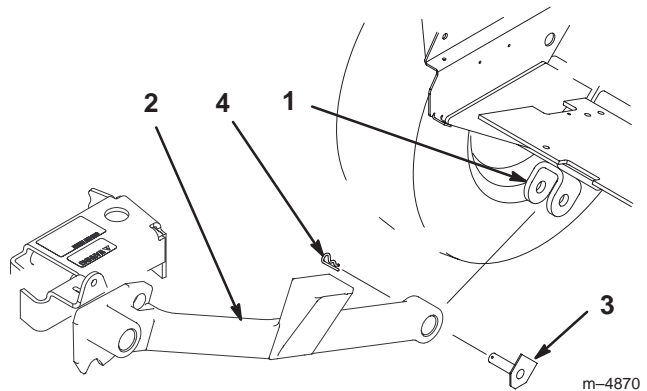

**Figure 24**

- |                 |                  |
|-----------------|------------------|
| 1. Bar          | 4. Machine Panel |
| 2. Rubber Guard | 5. Screw         |
| 3. Nut          |                  |

12. Remove hairpin cotters and pivot pin assemblies from push arms at traction unit pivot brackets (Fig. 25).

**Note:** Save all hardware for use when installing mower. Items 3 and 4 are part of traction unit.

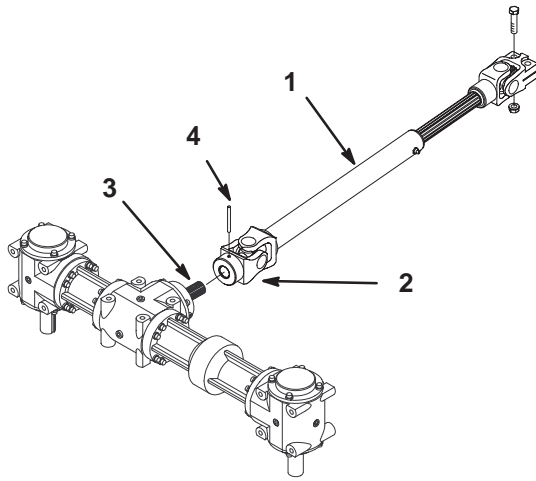

**Figure 25**

- |                  |                            |
|------------------|----------------------------|
| 1. Pivot Bracket | 3. Pivot Pin Assembly—flat |
| 2. Push Arm      | 4. Hairpin Cotter          |

**Note:** Drive shaft remains with traction unit.

13. Drive roll pin through hole in PTO drive shaft to separate from gearbox shaft (Fig. 26).



**Figure 26**

- |                    |                  |
|--------------------|------------------|
| 1. PTO Driveshaft  | 3. Gearbox shaft |
| 2. Universal Joint | 4. Roll Pin      |

M-4532

- Slide the driveshaft on gearbox shaft. Install 2 bolts (3/8 x 1-5/8 inches) and locknuts (3/8 inch) in universal joint (Fig. 28).

**Note:** The gearbox shaft has a spline to correctly align gearbox and PTO drive shaft. Align the spline and slide the PTO drive shaft onto gearbox.

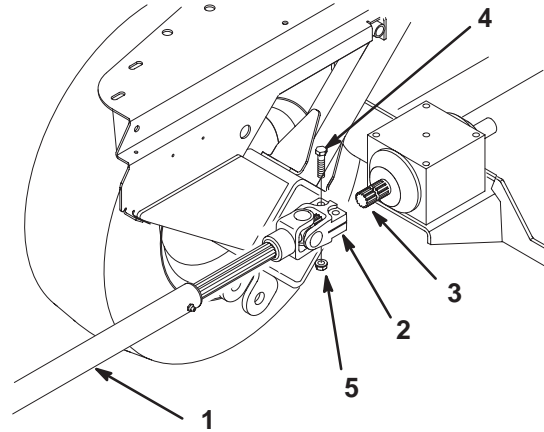

**Figure 28**

- |                    |                           |
|--------------------|---------------------------|
| 1. PTO Driveshaft  | 4. Bolt, 3/8 x 1-5/8 inch |
| 2. Universal Joint | 5. Locknut, 3/8 inch      |
| 3. Gearbox shaft   |                           |

m-3198

- Move deck and carrier frame away from traction unit.

**Important** Remove drive shaft from gearbox shaft if you do not hook up a deck immediately or when putting on optional attachments.

- Remove 2 bolts (3/8 x 1-5/8 inches) and locknuts (3/8 inch) from universal joint and slide the driveshaft off gearbox shaft (Fig. 27).

**Note:** Save all hardware for use when installing mower.

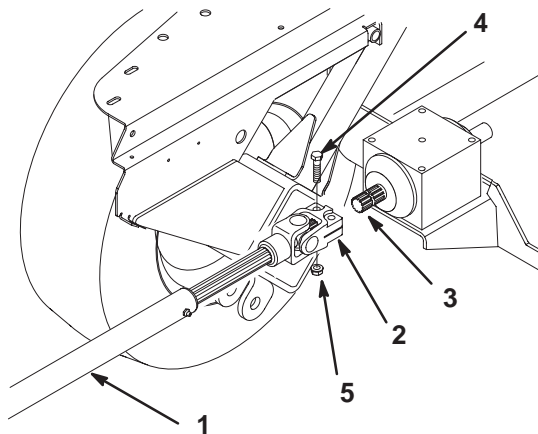

**Figure 27**

- |                    |                             |
|--------------------|-----------------------------|
| 1. PTO Driveshaft  | 4. Bolt, 3/8 x 1-5/8 inches |
| 2. Universal Joint | 5. Locknut, 3/8 inch        |
| 3. Gearbox shaft   |                             |

m-3198

- Position carrier frame in front of traction unit and place push arms into clevises (Fig. 29).
- Install push arms with pivot pin assemblies, aligned with flat against frame, and secure with hairpin cotters (Fig. 29).

**Note:** Pivot pin assemblies and hairpin cotters are part of traction unit.

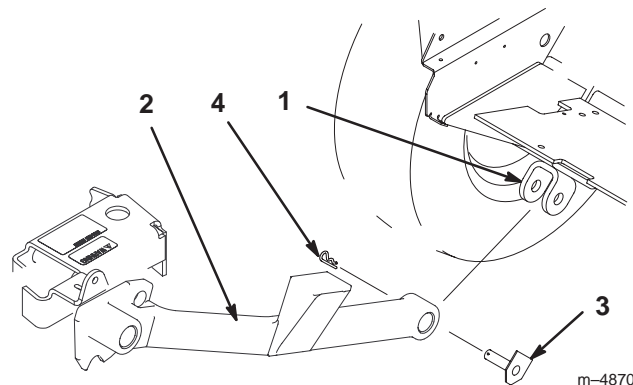

**Figure 29**

- |             |                            |
|-------------|----------------------------|
| 1. Clevis   | 3. Pivot Pin Assembly—flat |
| 2. Push Arm | 4. Hairpin Cotter          |

m-4870

- Tilt carrier frame into its upright position. Refer to Tilting the Mower on page 19.

## Installing Deck and Carrier Frame

**Note:** Install drive shaft to gearbox shaft if it is not hooked up. Proceed to step 2 if the driveshaft is hooked up.

- Place a block, approximately 4 inches high, under the carrier frame. This will raise the frame vertically.
- Secure spring end plate assembly to carrier frame with a shoulder bolt (3/8 x 7/8 inch) and a locknut (3/8 inch) (Fig. 30).

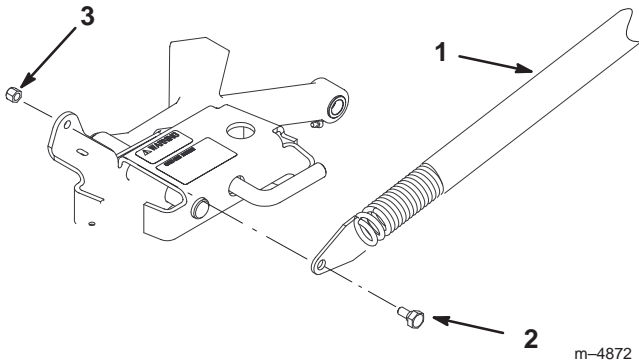
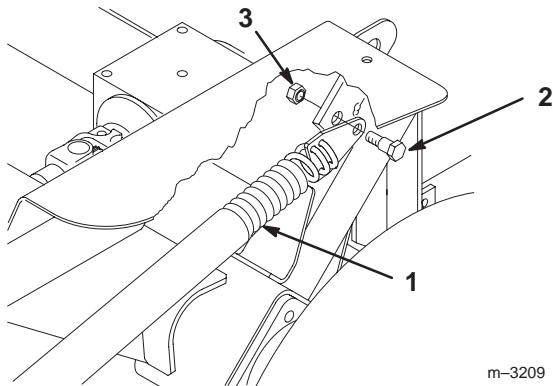

**Figure 30**

- Spring Assembly
- Shoulder Bolt, 3/8 x 7/8 inch
- Locknut, 3/8 inch

**Note:** You may have to install spring to traction unit if it is not installed.

- Install shoulder bolts (3/8 x 7/8 inch) and locknuts (3/8 inch) securing spring end plate assemblies to traction unit (Fig. 31).



**Figure 31**

- Spring Assembly
- Shoulder Bolt, 3/8 x 7/8 inch
- Locknut, 3/8 inch

- Position mower in front of traction unit.
- Rotate PTO drive shaft so holes align with hole in gearbox shaft and slide together (Fig. 32).
- Drive roll pin through hole to secure PTO drive shaft to gearbox shaft (Fig. 32).

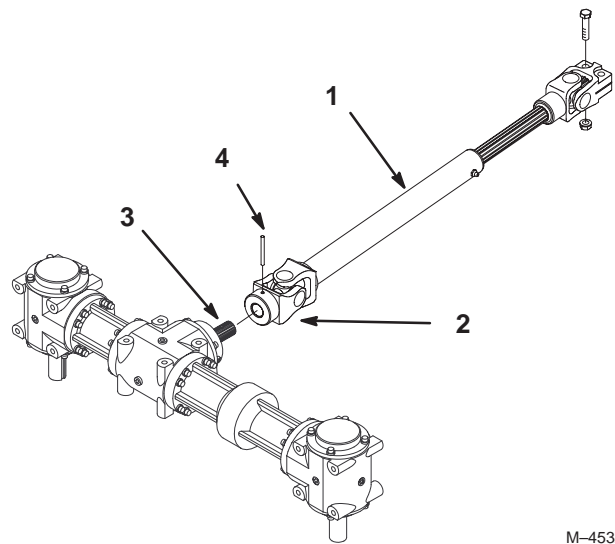

**Figure 32**

- PTO Driveshaft
- Universal Joint
- Gearbox shaft
- Roll Pin

- Remove the 4 inch block. Release the latch levers and push carrier frame down. Latch pins should lock.
- Select hole in height-of-cut post corresponding to the height-of-cut desired. Lift on side and front to align holes and hairpin cotter (Fig. 33).

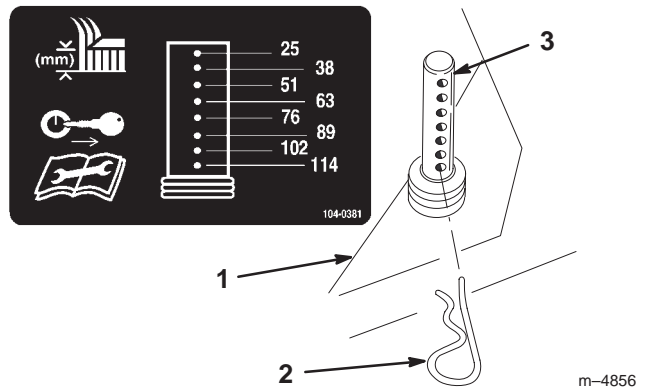
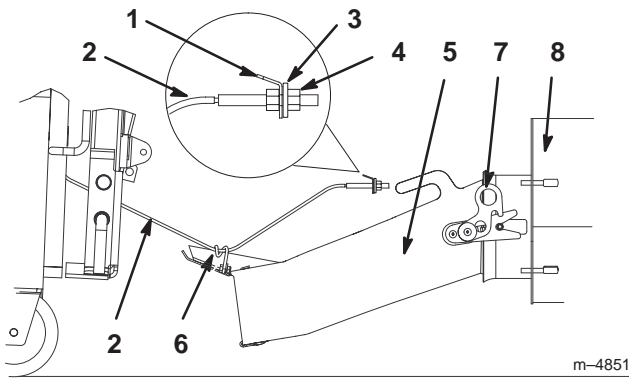

**Figure 33**

- Carrier Frame
- Hairpin Cotter
- Height-of-Cut Post

**Note:** All four hairpin cottes should be in the same hole location for a level cut.

- Tilt carrier frame into its upright position. Refer to Tilting the Mower on page 19.
- Route plenum cable under seat. Raise seat, to gain access to plenum cable. Install cable into bracket and install washer and nut (Fig. 34).

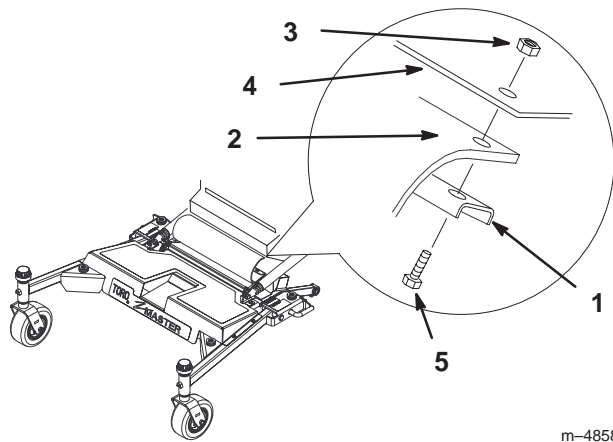

**Figure 34**

- |                 |                       |
|-----------------|-----------------------|
| 1. Bracket      | 5. Plenum             |
| 2. Plenum Cable | 6. Plenum cable guide |
| 3. Washer       | 7. Plenum Latches     |
| 4. Nut          | 8. Blower Housing     |

15. Install plenum to blower housing and wrap cable around guide. Refer to Installing and Removing the Plenum on page 27.

16. Install the rubber guard with bar, nuts and bolts under the motion control levers. (Fig. 35).



**Figure 35**

- |                 |                  |
|-----------------|------------------|
| 1. Bar          | 4. Machine Panel |
| 2. Rubber Guard | 5. Screw         |
| 3. Nut          |                  |

## Install the Mulching Baffle

Hardware to install mulching baffle is installed in deck.

1. Tilt mower into the vertical position, refer to; Tilting the Mower, page 19.
2. Remove screws, washers, left and right bagger baffles locknuts, carriage bolts, and left and right discharge baffles from the mower (Fig. 38).

**Note:** Reinstall all hardware into deck for use when reinstalling bagging baffles and safety.

3. Remove screws and washers that are installed into deck for securing mulching baffle (Fig. 36).
4. Install baffle using hardware that was removed. (Fig. 36).

**Important** All bagging and discharge baffles must be removed when mulching (Fig. 38).

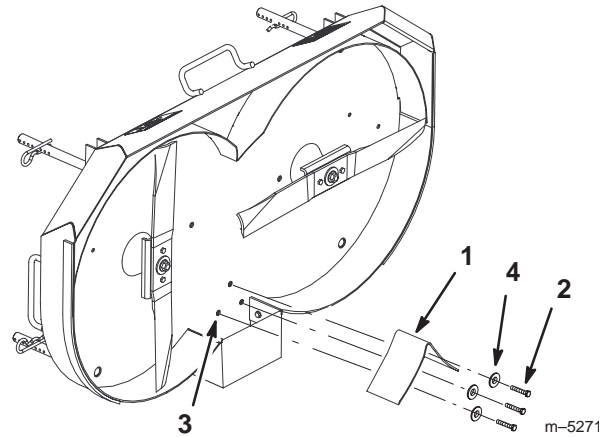

**Figure 36**

- |                    |                                       |
|--------------------|---------------------------------------|
| 1. Mulching baffle | 3. Retainer Nut (On top side of deck) |
| 2. Cap Screw       | 4. Washer                             |

## Operating with Mulching Baffle

When operating the mower with the mulching baffle installed, you must disengage the blower drive belt.

1. Stop the engine, remove the key and disconnect the spark plug wire(s) from the spark plug(s).
2. Remove hairpin cotter and clevis pin from idler arm (Fig. 37).
3. Pull up on the spring loaded idler arm, behind blower on lefthand side of unit, to relax pressure on blower belt (Fig. 37).

- Align hole in idler arm with slot in frame and insert clevis pin. Secure with hairpin cotter to hold in position.

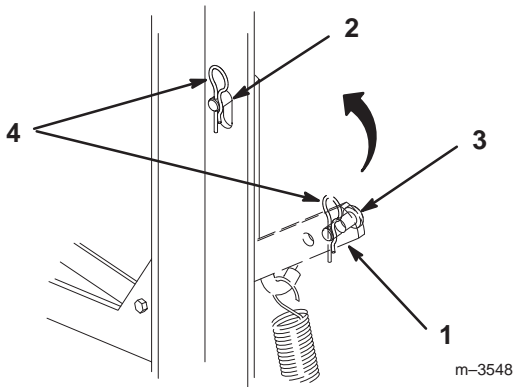

**Figure 37**

- |               |                   |
|---------------|-------------------|
| 1. Idler arm  | 3. Clevis pin     |
| 2. Frame slot | 4. Hairpin cotter |

- When operating in mulching mode, the plenum can be removed to prevent damage to it. Refer to Installing and Removing the Plenum on page 27.

## Installing the Bagger and Discharge Baffles

When changing from mulching to bagging, baffles must be removed and replaced

- Tilt mower into the vertical position, refer to Tilting the Mower on page 19.
- Remove screws, washers and mulching baffle from the mower (Fig. 36).

**Note:** Reinstall cap screws into deck for use when installing mulching baffle and safety.

- Position the left and right front bagger baffles inside the mower and secure with screws into the retainer nuts (Fig. 38).
- Position the left and right rear discharge baffles inside the mower. Secure with screws and washers through the bottom and carriage bolts inside of mower rear discharge. Secure carriage bolts with locknuts (Fig. 38).

**Important** All bagging baffles and discharge baffles must be in place when bagging.

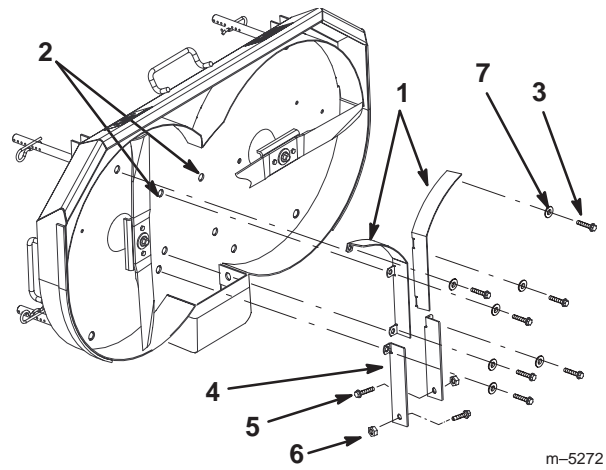

**Figure 38**

- |                     |                  |
|---------------------|------------------|
| 1. Bagger baffle    | 5. Carriage Bolt |
| 2. Retainer Nut     | 6. Lock Nut      |
| 3. Cap Screw        | 7. Washer        |
| 4. Discharge baffle |                  |

## Operating with Bagger

When operating the mower with bagger baffles installed you must engage the blower drive belt.

- Stop the engine, remove the key and disconnect the spark plug wire(s) from the spark plug(s).
- Ensure belt is around blower, idler and PTO pulleys.
- Push up on the spring loaded idler arm, behind blower on lefthand side of unit, to relax pressure on clevis pin (Fig. 39).
- Remove hairpin cotter and clevis pin from slot in frame and allow idler down, to tension belt (Fig. 39).
- Install hairpin cotter and clevis pin in outer hole of idler arm for storage (Fig. 39).

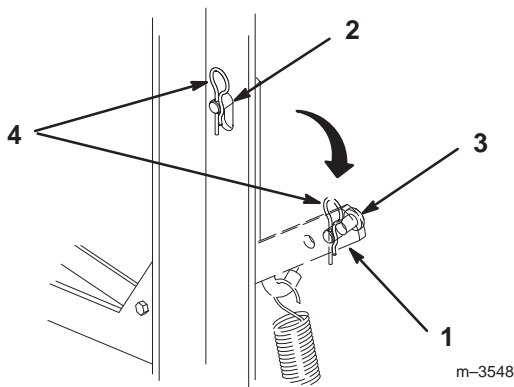

**Figure 39**

- |               |                   |
|---------------|-------------------|
| 1. Idler arm  | 3. Clevis pin     |
| 2. Frame slot | 4. Hairpin cotter |

## Installing and Removing the Plenum

To avoid damage to the plenum, remove the plenum when not in bagging mode.

! **Caution** !

**Hands and fingers can be cut when removing bagging components.**

- **Keep hands and fingers out of blower housing.**
- **Do not operate in bagging mode without entire bagging system in place.**
- **Stop engine before cleaning bagging system.**

### Removing the Removal

1. Disengage the power take off (PTO), set the parking brake, and turn the ignition key to off. Remove the key.
2. Tilt deck to upright position. Refer to Tilting the Mower on page 19.
3. Reach through from lefthand side in front of traction tire, lift plenum and unwind cable clockwise around plenum cable guide.

4. Flip seat up and unlatch plenum from both sides of blower inlet (Fig. 40).
5. Pull plenum out from blower housing and place it on the ground (Fig. 40).
6. Pull or slide plenum out from between deck and traction tire (Fig. 40).

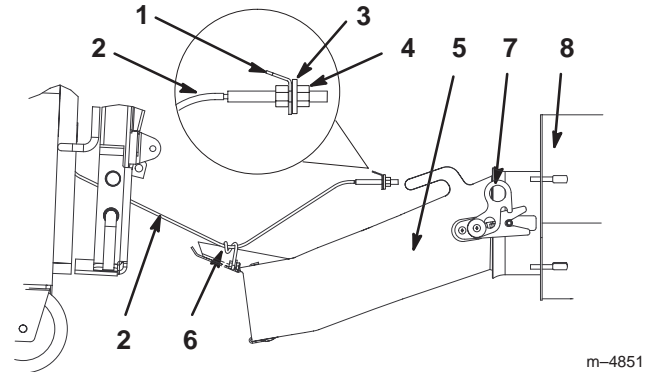

**Figure 40**

- |                 |                       |
|-----------------|-----------------------|
| 1. Bracket      | 5. Plenum             |
| 2. Plenum Cable | 6. Plenum cable guide |
| 3. Washer       | 7. Plenum Latches     |
| 4. Nut          | 8. Blower Housing     |

### Installing the Plenum

1. Tilt deck to upright position. Refer to Tilting the Mower on page 19.
2. Slide plenum, with blower end in first, between deck and traction tire.
3. Flip seat up, reach down and direct plenum into blower housing. Ensure the plenum latches lock into both sides of blower housing (Fig. 40).
4. Reach through from lefthand side in front of traction tire, lift plenum and wind cable counter clockwise around plenum cable guide (Fig. 40).

# Maintenance

**Note:** Determine the left and right sides of the machine from the normal operating position.

## Recommended Maintenance Schedule

Maintenance Service Interval	Maintenance Procedure
After first use	<ul style="list-style-type: none"> <li>• Check the hydraulic fluid level.</li> <li>• Change the oil.</li> <li>• Change the hydraulic filter.</li> </ul>
Each use	<ul style="list-style-type: none"> <li>• Check the oil level.<sup>1</sup></li> <li>• Check the safety system.</li> <li>• Clean the hopper.</li> <li>• Clean the mower housing.</li> <li>• Clean the cooling systems.</li> </ul>
Every 5 hours	<ul style="list-style-type: none"> <li>• Check the hydraulic fluid level.</li> <li>• Check the cutting blades.</li> <li>• Grease the chassis.<sup>1</sup></li> <li>• Grease the drive shaft.<sup>1</sup></li> <li>• Grease the push arm bearings.</li> <li>• Grease the PTO idler.<sup>1</sup></li> <li>• Check the battery electrolyte.</li> </ul>
Every 25 hours	<ul style="list-style-type: none"> <li>• Grease the castor wheels.</li> <li>• Service the foam air cleaner.<sup>1</sup></li> </ul>
Every 50 hours	<ul style="list-style-type: none"> <li>• Check the belts for wear/cracks.</li> <li>• Check the tire pressure.</li> </ul>
After first 100 hours	<ul style="list-style-type: none"> <li>• Change the mower gearbox oil.</li> </ul>
Every 100 hours	<ul style="list-style-type: none"> <li>• Change the engine oil.</li> <li>• Check the mower gearbox oil.</li> <li>• Check the primary air cleaner.<sup>1</sup></li> <li>• Check the hydraulic lines.</li> <li>• Change the mower gearbox oil (after initial 100 hours).</li> <li>• Clean the cooling systems.</li> </ul>
Every 200 hours	<ul style="list-style-type: none"> <li>• Change the oil filter.</li> <li>• Change the hydraulic filter.</li> <li>• Check the spark plug(s).</li> <li>• Replace the fuel filter.</li> </ul>
Every 600 hours	<ul style="list-style-type: none"> <li>• Replace the safety air cleaner.<sup>1</sup></li> </ul>
Before storage	<ul style="list-style-type: none"> <li>• Change the mower gearbox oil.</li> <li>• Perform all maintenance procedures listed above before storage</li> <li>• Drain the gasoline.</li> <li>• Charge the battery and disconnect the cables.</li> <li>• Paint chipped surfaces.</li> </ul>

<sup>1</sup>More often in dusty, dirty conditions

**Important** Refer to your engine operator's manual for additional maintenance procedures.

! **Caution** !

**If you leave the key in the ignition switch, someone could accidentally start the engine and seriously injure you or other bystanders.**

**Remove the key from the ignition and disconnect the wire(s) from the spark plug(s) before you do any maintenance. Set the wire(s) aside so that it does not accidentally contact the spark plug(s).**

## Servicing the Cutting Blades

To ensure a superior quality of cut, keep the blades sharp. For convenient sharpening and replacement, you may want to keep extra blades on hand.

! **Danger** !

**A worn or damaged blade can break, and a piece of the blade could be thrown into the operator's or bystander's area, resulting in serious personal injury or death.**

- **Inspect the blade periodically for wear or damage.**
- **Replace a worn or damaged blade.**

Blades must be replaced if a solid object is hit, if the blade is out of balance or is bent. To ensure optimum performance and continued safety conformance of the machine, use genuine TORO replacement blades. Replacement blades made by other manufacturers may result in non-conformance with safety standards.

**Important** Always check gearbox output shafts for straightness after impacting solid objects with blades. Severe damage could result if gearbox is operated with bent output shafts

## Before Inspecting or Servicing the Blades

Park the machine on a level surface, disengage the blade control (PTO) and set the parking brake. Turn the ignition key to off. Remove the key and disconnect the spark plug wire(s) from the spark plug(s).

## Inspecting the Blades

1. Inspect the cutting edges (Fig 41). If the edges are not sharp or have nicks, remove and sharpen the blades. Refer to Sharpening the Blades on page 31.
2. Inspect the blades, especially the curved area (Fig. 41). If you notice any damage, wear, or a slot forming in this area (item 3 in Fig. 41), immediately install a new blade.

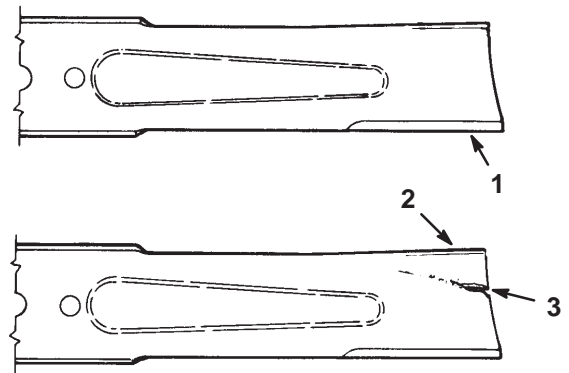

m-151

**Figure 41**

1. Cutting Edge
2. Curved Area
3. Wear/slot Forming

## Checking for Bent Blades

1. Rotate the blades until the ends face forward and backward (Fig. 42). Measure from a level surface to the cutting edge tip of the blades (Fig. 42). Note this dimension.
2. Rotate the opposite ends of the blades forward. Measure from a level surface to the cutting edge tip of the blades at the same position as in step 1 above. The difference between the dimensions obtained in steps 1 and 2 must not exceed 3 mm (1/8 inch). If this dimension exceeds

3 mm (1/8 inch), the blade is bent and must be replaced. Refer to Removing the Blades, and Installing the Blades on page 30.

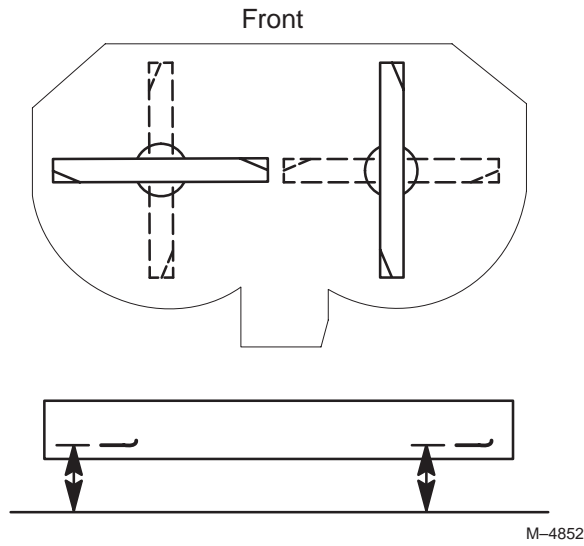

Figure 42

**Warning**

A blade that is bent or damaged could break apart and could seriously injure or kill you or bystanders.

- Always replace a bent or damaged blade with a new blade.
- Never file or create sharp notches in the edges or surfaces of the blade.

## Removing the Blades

Hold the blade end using a rag or thickly-padded glove. Remove the retainer bolt with its washer and spacer, and the shear bolts and locknuts from the blade retainer (Fig. 44).

## Installing the Blades

**Important** The blades are different for each side and rotate in opposite directions forcing clippings to the center rear of the mower. Align cutting edges properly when installing. Sails of blades must point towards the top of the deck.

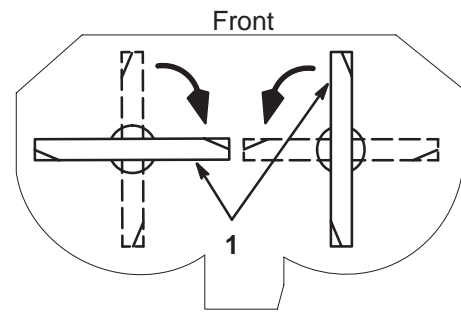

Figure 43

1. Cutting edge

**Note:** Use anti-seize lubricant on spindle and keyway before installing blade retainer.

1. Install the key in the retainer and install blade retainer to spindle (Fig. 44).
2. Install the blade, spacer, washer, and retainer bolt to spindle (Fig. 44).
3. Torque the retainer bolt to 115–140 N  $\cdot$ m (85–110 ft.-lb.).

**Important** Blade should spin after blade bolt is torqued. If not, check to make sure the spacer is installed correctly.

4. Position the blade onto the blade retainer and secure with shear bolts and locknuts (Fig. 44).

**Important** The curved part of the blade, the sail, must be pointing upward toward the top of the mower to ensure proper cutting.

5. Torque blade shear bolts to 10.2 N  $\cdot$ m (90 in.-lb.).

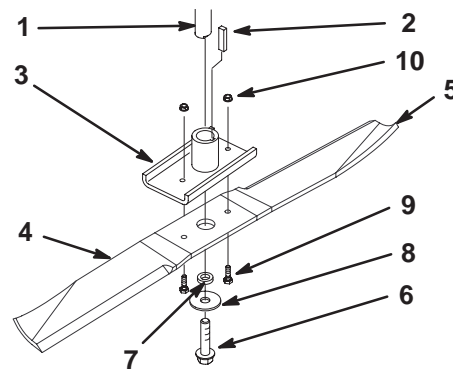
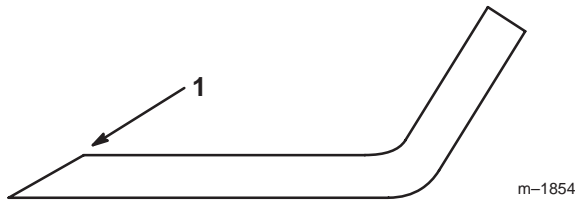

Figure 44

- |                       |                  |
|-----------------------|------------------|
| 1. Spindle            | 6. Retainer bolt |
| 2. Key                | 7. Spacer        |
| 3. Blade retainer     | 8. Washer        |
| 4. Blade              | 9. Shear Bolt    |
| 5. Sail Area of Blade | 10. Locknut      |

## Sharpening the Blades

1. Use a file to sharpen the cutting edge at both ends of the blade (Fig. 45). Maintain the original angle. The blade retains its balance if the same amount of material is removed from both cutting edges.



**Figure 45**

1. Sharpen at original angle

2. Check the balance of the blade by putting it on a blade balancer (Fig. 46). If the blade stays in a horizontal position, the blade is balanced and can be used. If the blade is not balanced, file some metal off the end of the sail area only (Fig. 46). Repeat this procedure until the blade is balanced.

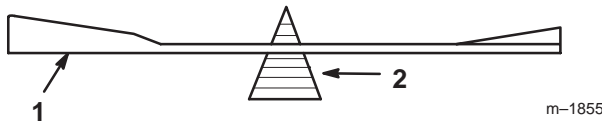

**Figure 46**

1. Blade
2. Balancer

## Correcting Cutting Unit Mismatch

If one deck blade cuts lower than the other, correct as follows:

1. Stop the engine, remove the key and disconnect the spark plug wire(s) from the spark plug(s).
2. Adjust the tire pressure in all tires to specifications and check that the blades and spindle shafts are not bent. Refer to Checking for Bent Blades on page 29.
3. Set the height-of-cut to the 63 mm (2-1/2 inches) position. Refer to Adjusting the Height-Of-Cut in the Operation section. Make sure there is no excessive wear on push arm pivot points.
4. Refer to Matching Height-of-Cut, Checking Front to Rear Pitch and Checking Side to Side Leveling on pages 31, 31 and 32.

## Matching the Height-of-Cut

The height of cut needs to be checked and correct before the front to rear pitch and side to side leveling is performed.

1. Check the tire pressure on both deck and traction unit.
2. Set the height-of-cut to the 2-1/2 inches (63 mm) position following the height-of-cut decal.
3. With the machine on level surface, position one blade front-to-rear (Fig. 47). Measure at **A** from level surface to the cutting edge of the blade tips (Fig. 48).
4. The measurement should be 2-1/2 inches (63 mm). Rotate blades and repeat for opposite blade.

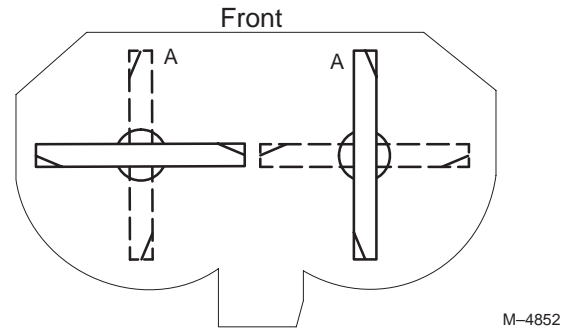

**Figure 47**

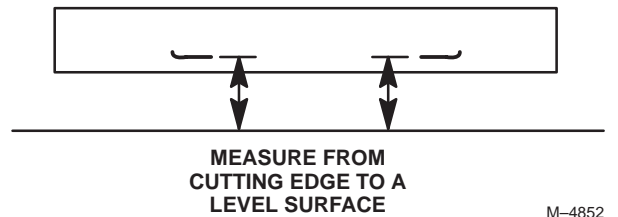

**Figure 48**

5. If it does not measure correctly remove or add washers to the height-of-cut posts. Match the hole in the post with the decal and the measured height-of-cut (Fig. 33).

**Note:** Make sure you add or remove washers from all four height-of-cut posts.

## Checking the Front-to-Rear Pitch

The height of cut needs to be checked and correct before the front to rear pitch leveling is performed.

1. Check the tire pressure on both deck and traction unit.
2. Position one blade front-to-rear (Fig. 49). Measure at **C** and **D** locations (Fig. 49) from a level surface to the cutting edge of the blade tips (Fig. 50).
3. The mower blade should be 6–9.5 mm (1/4–3/8 inch) lower in front **C** than in the rear **D**. Rotate blades and repeat for opposite blade. If it is not correct proceed to Change the Front-to-Rear Pitch.

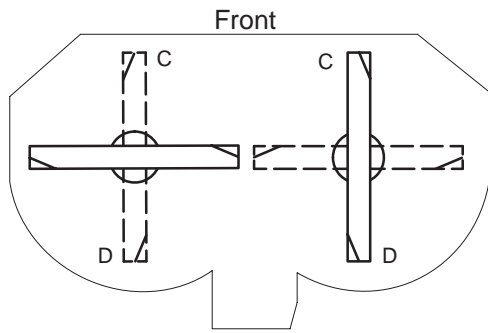

M-4852

Figure 49

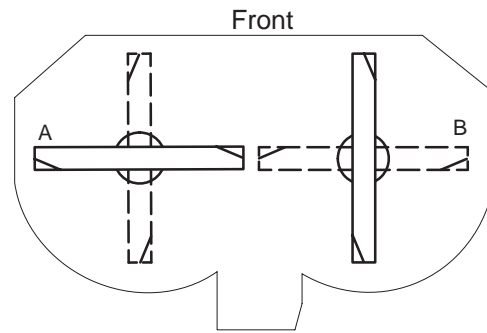

M-4852

Figure 51

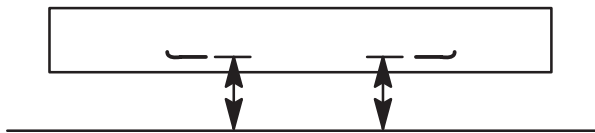

MEASURE FROM TIP  
OF CUTTING EDGE  
TO A LEVEL SUR-  
FACE

M-4852

Figure 50

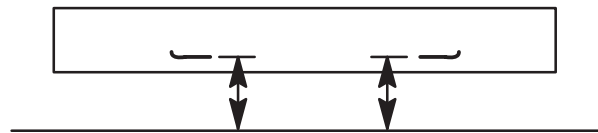

MEASURE FROM TIP  
OF CUTTING EDGE  
TO A LEVEL SUR-  
FACE

M-4852

Figure 52

## Changing the Front-to-Rear Pitch

Changing the front-to-rear pitch is done by removing or adding washers to height of cut posts.

1. Check the tire pressure on both deck and traction unit.
2. To change the front-to-rear pitch, remove the hairpin cotter and move an equal number of washers on front or rear height-of-cut posts.
3. Add washers to the height-of-cut posts to raise the mower.
4. Remove washers from the height-of-cut posts to lower the mower.
5. Check the Front-to-Rear Pitch.

## Checking the Side-to-Side Level

The height of cut needs to be checked and correct before the side to side leveling is performed.

1. Check the tire pressure on both deck and traction unit.
2. Position the blades side-to-side (Fig. 51). Measure at **A** and **B** locations (Fig. 51) from a level surface to the cutting edge of blade tips (Fig. 52).
3. The difference between measurements **A** and **B** should be no more than 6 mm (1/4 inch).

## Change the Side-to-Side Level

Changing the side-to-side leveling is done by removing or adding washers to height of cut posts. Do this to the corresponding side that needs adjustment.

1. Check the tire pressure on both deck and traction unit.
2. To change the side-to-side leveling, remove the hairpin cotter and remove or add washers on one side only.
3. Add washers to the height-of-cut posts to raise the corresponding side of the mower.
4. Remove washers from the height-of-cut posts to lower the corresponding side of the mower.
5. Recheck the front-to-rear pitch and side to side leveling of the cutting unit.

## Servicing the Air Cleaner

Primary Filter: Clean or replace every 200 operating hours or when Filter Minder reaches "Change Filter" level.

Safety Filter: Replace after every 600 operating hours.

**Note:** Service the air cleaner more frequently if operating conditions are extremely dusty or sandy.

## Using the Filter Minder

This machine contains an air cleaner **Filter Minder** gauge.

Filter Minder: Check this daily.

The plunger inside the gauge canister will change to red when the air cleaner element becomes dirty and restricted. When it changes red, air cleaner maintenance is required.

1. Start by visually checking the condition of the primary element. If the element is visually dirty, replace the primary element. **Do not attempt to clean it.**
2. Reset the gauge by depressing the button in the bottom of the canister until the plunger returns to the lowest point (Fig. 53).
3. Test run the engine and recheck the gauge. If the plunger remains in the lowest range, normal operation can resume. If the plunger returns to the "Change Filter" level, the primary element is restricted and must be replaced, even though it may not appear to be dirty.
4. The gauge may be reset at any time, however it will return to the prior position if corrective filter servicing has not been performed.

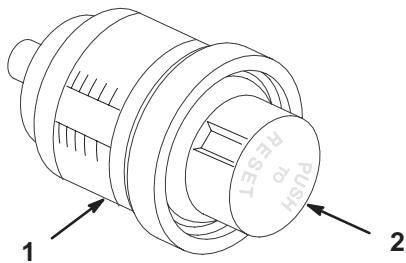

M-4824

**Figure 53**

1. Filter minder
2. Button (push to reset)

## Removing the Filter

1. Disengage the power take off (PTO), set the parking brake, and turn the ignition key to off. Remove the key.
2. Remove the wing nut from the bolt in the air filter guard. Rotate guard to gain access to filter (Fig. 54).

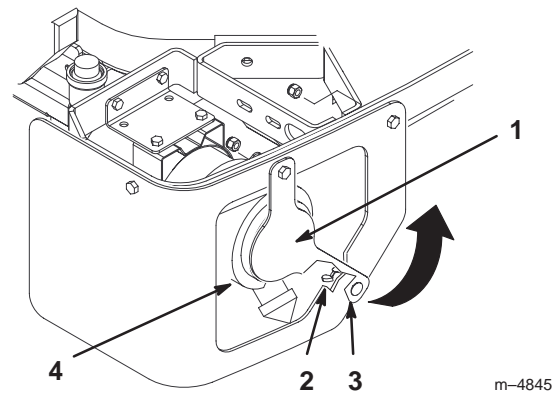

m-4845

**Figure 54**

1. Filter guard
2. Wing nut
3. Bolt
4. Filter

3. Release the latches on the air cleaner and pull the air cleaner cover off of the air cleaner body (Fig. 55).
4. Clean the inside of the air cleaner cover with compressed air.
5. Gently slide the primary filter out of the air cleaner body (Fig. 55). Avoid knocking the filter into the side of the body. Do not remove the safety filter, unless you intend to replace it as well.
6. Inspect the primary filter for damage by looking into the filter while shining a bright light on the outside of the filter. Holes in the filter will appear as bright spots. If the filter is damaged, discard it, otherwise clean it.

**Important** Never attempt to clean the safety filter. If the safety filter is dirty, then the primary filter is damaged and you should replace both filters.

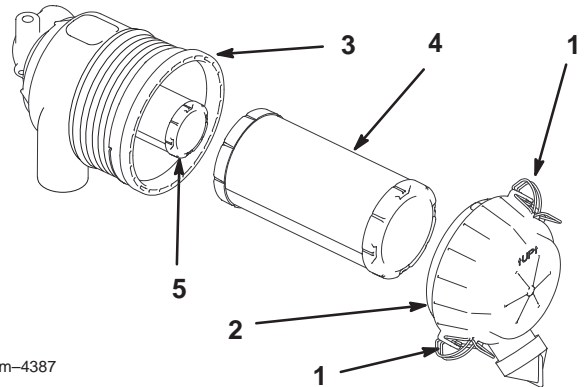

m-4387

**Figure 55**

1. Latches
2. Air cleaner cover
3. Air filter body
4. Primary filter
5. Safety filter



## Changing the Engine Oil

1. Start the engine and let it run five minutes. This warms the oil so it drains better.
2. Park the machine so that the drain side is slightly lower than the opposite side to assure the oil drains completely. Then disengage the power take off (PTO), set the parking brake, and turn the ignition key to off. Remove the key.
3. Place a pan below the oil drain. Remove the oil drain cap (Fig. 57).
4. When oil has drained completely, install the drain cap.

**Note:** Dispose of the used oil at a recycling center.

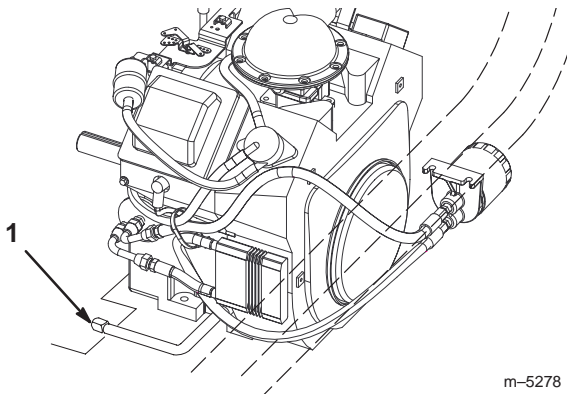

**Figure 57**

1. Oil drain cap

5. Slowly pour approximately 80% of the specified oil, on page 34, into the fill opening (Fig. 56). Now check the oil level; refer to Checking Oil Level, page 34. Slowly add additional oil to bring to full mark on dipstick.

## Changing the Engine Oil Filter

Replace the oil filter after first 8 hours of use.

Replace the oil filter every 200 hours or every other oil change.

**Note:** Change oil filter more frequently when operating conditions are extremely dusty or sandy.

1. Drain the oil from the engine; refer to Changing/Draining Oil, page 35.
2. Remove the old filter and wipe the filter adapter (Fig. 58) gasket surface.
3. Pour new oil of the proper type in through the center hole. Stop pouring when the oil reaches the bottom of the threads. Allow a minute or two for the oil to be absorbed by filter material.
4. Apply a thin coat of new oil to the rubber gasket on the replacement filter (Fig. 58).

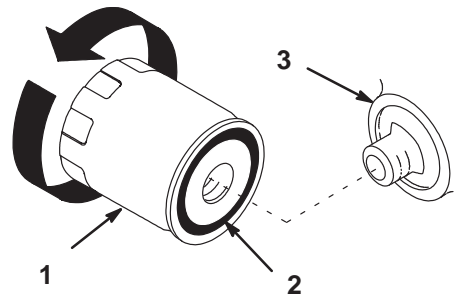

**Figure 58**

1. Oil filter
2. Gasket
3. Adapter

5. Install the replacement oil filter to the filter adapter. Turn the oil filter clockwise until the rubber gasket contacts the filter adapter, then tighten the filter an additional 1/2 turn (Fig. 58).
6. Fill the crankcase with the proper type of new oil; refer to Changing/Draining Oil, page 35.

## Servicing the Spark Plugs

Check the spark plug(s) after every 200 operating hours. Make sure the air gap between the center and side electrodes is correct before installing the spark plug. Use a spark plug wrench for removing and installing the spark plug(s) and a gapping tool/feeler gauge to check and adjust the air gap. Install a new spark plug(s) if necessary.

Type: Champion Premium Gold 2071 (or equivalent)  
Air Gap: 0.030 inch (0.76 mm)

## Removing the Spark Plugs

1. Disengage the power take off (PTO), set the parking brake, and turn the ignition key to off. Remove the key.
2. Pull the wire(s) off the spark plug(s) (Fig. 59). Now clean around the spark plug(s) to prevent dirt from falling into the engine and potentially causing damage.
3. Remove the spark plug(s) and metal washer.

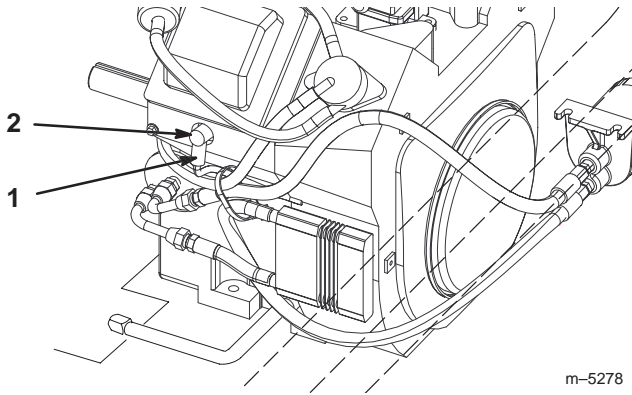

Figure 59

1. Spark plug wire
2. Spark plug

## Checking the Spark Plugs

1. Look at the center of the spark plug(s) (Fig. 60). If you see light brown or gray on the insulator, the engine is operating properly. A black coating on the insulator usually means the air cleaner is dirty.

**Important** Never clean the spark plug(s). Always replace the spark plug(s) when it has: a black coating, worn electrodes, an oily film, or cracks.

2. Check the gap between the center and side electrodes (Fig. 60). Bend the side electrode (Fig. 60) if the gap is not correct.

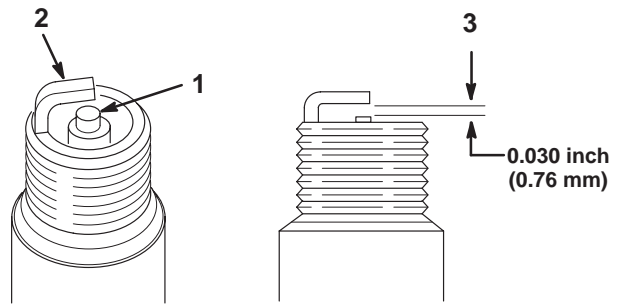

m-3215

Figure 60

1. Center electrode insulator
2. Side electrode
3. Air gap (not to scale)

## Installing the Spark Plug(s)

1. Install the spark plug(s). Make sure the air gap is set correctly.
2. Tighten the spark plug(s) to 27 N  (20 ft.-lb.).
3. Push the wire(s) onto the spark plug(s) (Fig. 59).

## Servicing the Fuel Filter

Replace the fuel filter after every 200 operating hours or yearly, whichever occurs first.

### Replacing the Fuel Filter

Never install a dirty filter if it is removed from the fuel line.

1. Disengage the power take off (PTO), set the parking brake, and turn the ignition key to off. Remove the key.
2. Close fuel shut-off valve at fuel tank (Fig. 62).
3. Squeeze the ends of the hose clamps together and slide them away from the filter (Fig. 61).
4. Remove the filter from the fuel lines.
5. Install a new filter and move the hose clamps close to the filter.
6. Open fuel shut-off valve at fuel tank (Fig. 62).



3. Install the panels onto the engine shroud.

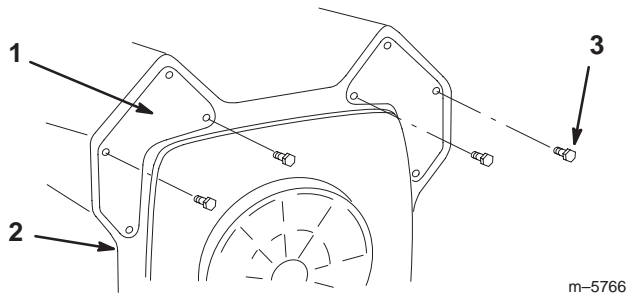

**Figure 64**

1. Panel
2. Engine shroud
3. Screws

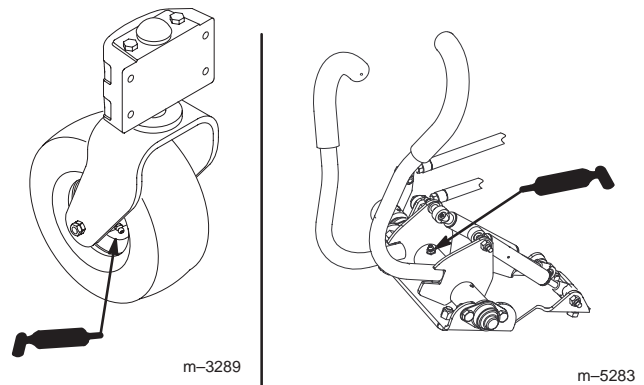

**Figure 65**

## Greasing and Lubricating

The unit must be lubricated regularly. Refer to the Recommended Maintenance Schedule on page 28.

Grease Type: No. 2 general purpose lithium base or molybdenum base grease.

### How to Grease

1. Disengage the power take off (PTO) and turn the ignition key to off. Remove the key.
2. Clean the grease fittings with a rag. Make sure to scrape any paint off the front of the fitting(s).
3. Connect a grease gun to the fitting. Pump grease into the fittings until grease begins to ooze out of the bearings.
4. Wipe up any excess grease.

### Where to Add Grease

1. Lubricate the castor wheel bearings and motion control lever pivot until grease begins to ooze out of the bearings (Fig. 65).

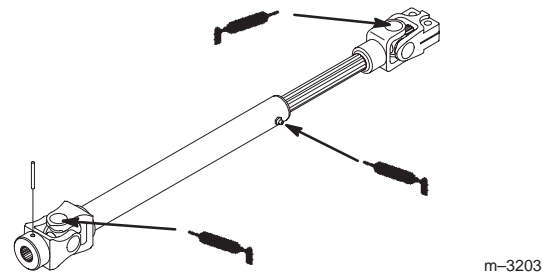

**Figure 66**

1. PTO Driveshaft
2. Universal Joint

3. Grease the fittings on push arms (Fig. 67).

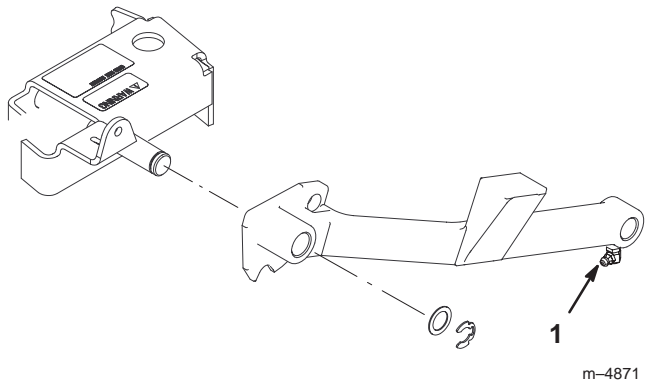

**Figure 67**

1. Push arm grease fitting

4. Grease the fittings on the carrier frame castor hubs and castor wheels (Fig. 68).

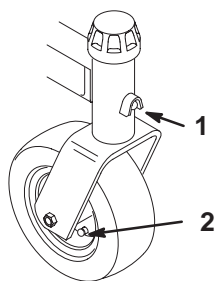

Figure 68

- |                                            |                                |
|--------------------------------------------|--------------------------------|
| 1. Carrier Frame Castor Hub Grease Fitting | 2. Castor Wheel Grease Fitting |
|--------------------------------------------|--------------------------------|

m-4846

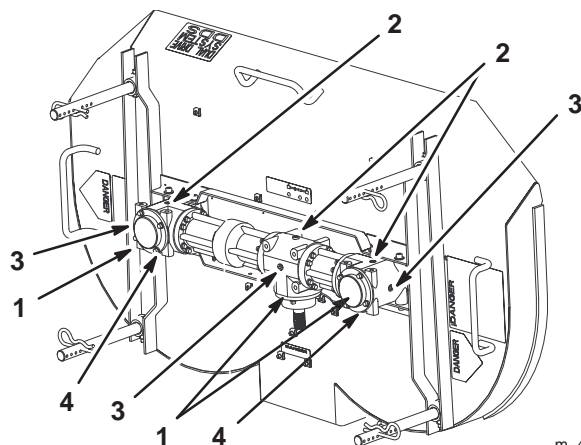

Figure 69

- |             |                |
|-------------|----------------|
| 1. Gearbox  | 3. Side plug   |
| 2. Top plug | 4. Bottom plug |

m-4857

## Servicing the Gearbox Fluid

Change fluid:

- after initial 100 operating hours.
- each year before storage.

Fluid Type: 85W-140 Mobilube  equivalent fluid.

**Important** Do not mix fluids.

Gearbox Capacity: 5-1/2 oz. (129.6 ml) each box  
16-1/2 oz. (488 ml) for all three boxes

Check fluid after every 100 operating hours.

## Changing the Gearbox Fluid

The gearbox fluid must be changed after first 100 operating hours. Change all three gearboxes.

**Important** Do not mix fluids. Use only specified fluid on page 39.

1. Warm the fluid in gearbox. Run the mower deck for a few minutes.
2. Tilt mower into the vertical position, refer to; Tilting the Mower, page 19.
3. With deck raised, remove plug on the bottom side of the gearbox. Let fluid fully drain into a pan. (Fig. 69).
4. Reinstall the bottom plug into the gearbox. Use pipe thread sealant if needed (Fig. 69).
5. Remove the top plug to fill gearbox (Fig. 69).
6. Fill gearbox with 129.6 ml (5-1/2 oz.) of fluid.
7. Reinstall the top plug into the gearbox (Fig. 69).
8. Repeat for remaining gearboxes.

## Checking the Gearbox Fluid

The gearbox fluid must be checked after every 100 operating hours. Check all three gearboxes.

1. Warm the fluid in gearbox. Run the mower deck for a few minutes.
2. Tilt mower into the vertical position, refer to; Tilting the Mower, page 19.
3. Remove plug on the side of the gearbox. The fluid level must be up to side hole in gearbox (Fig. 69).
4. If needed, fill fluid into top hole until it runs out the side hole in gearbox. It is full when it runs out the side hole (Fig. 69).

**Important** Do not mix fluids. Do not overfill gearboxes.

5. Reinstall the top and side plugs into gearbox using pipe sealant (Fig. 69).
6. Fill gearbox with fluid.
7. Repeat for remaining gearboxes.

## Replacing the Castor Wheel Fork Bushings

The castor wheel forks are mounted in bushings pressed into the top and bottom of the carrier frame castor tubes. To check the bushings, move the castor forks back and forth and side-to-side. If a castor fork is loose, the bushings are worn and must be replaced.

1. Tilt mower into the vertical position, refer to; Tilting the Mower, page 19.

- Remove the cap, thrust washer and 1/2 inch spacer from the top of the castor wheel fork (Fig. 70).
- Pull the castor wheel fork out of the mounting tube, leaving the 1 inch spacer and thrust washers on the fork. Remember the location of thrust washers on each fork to ensure correct installation, and to maintain a level deck.

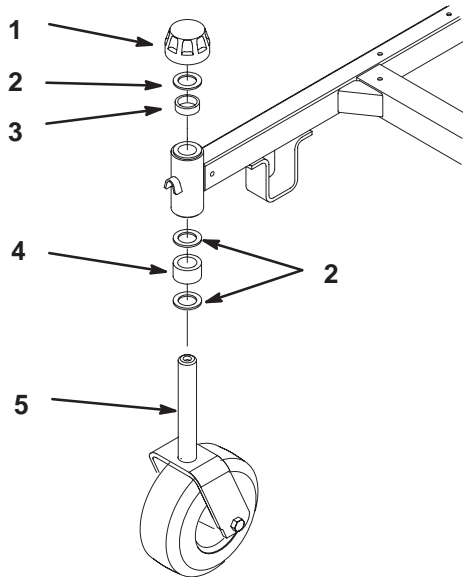

**Figure 70**

- |                                   |                           |
|-----------------------------------|---------------------------|
| 1. Cap                            | 4. Spacer, 26 mm (1 inch) |
| 2. Washer                         | 5. Caster Wheel Fork      |
| 3. Spacer, 13 mm (1/2 inch) (New) |                           |

- Insert a pin punch into the castor hub and carefully drive out the bushings (Fig. 71). Clean the inside of the mounting tube.
- Grease the inside and outside of the new bushings. Use a hammer and flat plate to carefully drive the bushings into the castor hub (Fig. 71).
- Inspect the castor wheel fork for wear and replace if necessary (Fig. 70).
- Slide the castor wheel fork through the bushings in the castor hub. Replace the 1/2 inch spacer and thrust washer onto the fork and secure with the cap (Fig. 70).

**Important** The inside diameter of the bushings may collapse slightly when installed. If the castor wheel fork does not slide into the new bushings, ream both bushings to an inside diameter of 28.6 mm (1.126 inches).

- Grease the fitting on the carrier frame castor hub using No. 2 general purpose lithium base or molybdenum base grease.

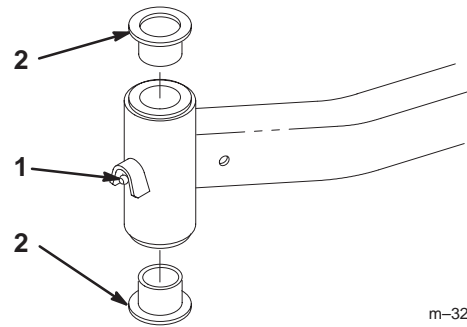

**Figure 71**

- |                             |            |
|-----------------------------|------------|
| 1. Carrier Frame Castor Hub | 2. Bushing |
|-----------------------------|------------|

## Replacing Idler Arm Bushings

There are idler arms for the blower belt, PTO belt and traction belt. All three idler arms have pressed in bushings. To check the bushings, move the idler arms side-to-side and examine for wear. If the idler arms are loose, the bushings are worn and must be replaced.

- Disengage the power take off (PTO) and turn the ignition key to off. Remove the key.
  - Remove tension on idler arms and remove belt from the idler. See one of the following figures 72, 73 or 74 that shows the idler you are checking.
  - Inspect the idler pivot pin assembly for wear and replace if necessary. To check the bushings, move the idler arms side-to-side and examine for wear.
  - If the idler arms are loose, the bushings are worn and must be replaced. Remove the hardware securing the idler pivot arm to the mower.
  - Insert a pin punch into the idler arm and carefully drive out the bushings (Figures 72, 73 or 74). Clean the inside of the idler arm.
  - Use a hammer and flat plate to carefully drive new bushings into the idler arm (Figures 72, 73 or 74).
  - Install the idler arm back onto the machine.
- Note:** Grease the PTO idler arm using No. 2 general purpose lithium base or molybdenum base grease.
- Install the belt back onto idler pulley.

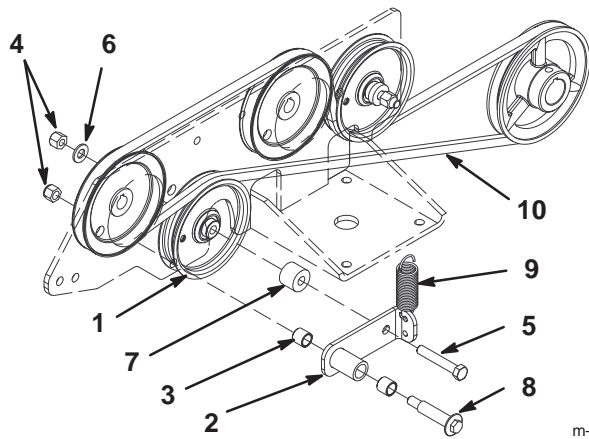

m-5299

**Figure 72**

- |                      |                   |
|----------------------|-------------------|
| 1. Pump Idler Pulley | 6. Washer         |
| 2. Idler arm         | 7. Spacer         |
| 3. Bushing           | 8. Shoulder bolt  |
| 4. Nut               | 9. Spring         |
| 5. Bolt              | 10. Traction Belt |

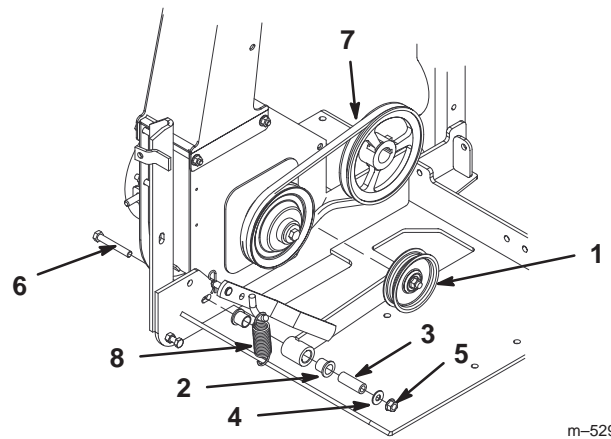

m-5297

**Figure 74**

- |                        |                |
|------------------------|----------------|
| 1. Blower Idler Pulley | 5. Nut         |
| 2. Bushing             | 6. Bolt        |
| 3. Spacer              | 7. Blower Belt |
| 4. Washer              | 8. Spring      |

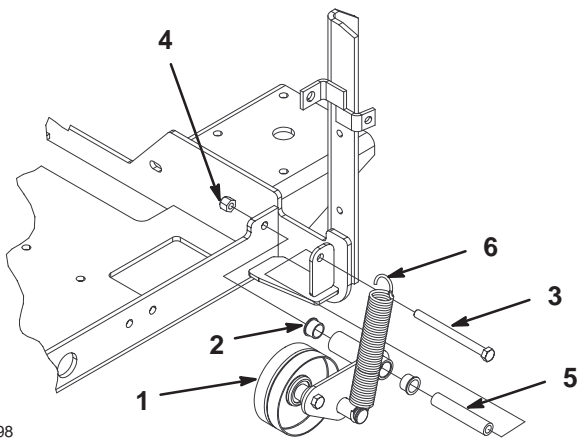

m-5298

**Figure 73**

- |                         |           |
|-------------------------|-----------|
| 1. PTO Idler and pulley | 4. Nut    |
| 2. Bushing              | 5. Spacer |
| 3. Bolt                 | 6. Spring |

## Replacing Push Arm Bushings

The push arms have pressed in bushings on the end mounted to the traction unit. To check the bushings, move the push arms side-to-side and examine for wear. If a push arm is loose, the bushings are worn and must be replaced.

1. Remove the mower: refer to Removing the Mower in the Installation section.
2. Inspect the pivot pin assembly for wear and replace if necessary.
3. Remove the retaining ring and flat washer securing the push arm to the mower (Fig. 75).

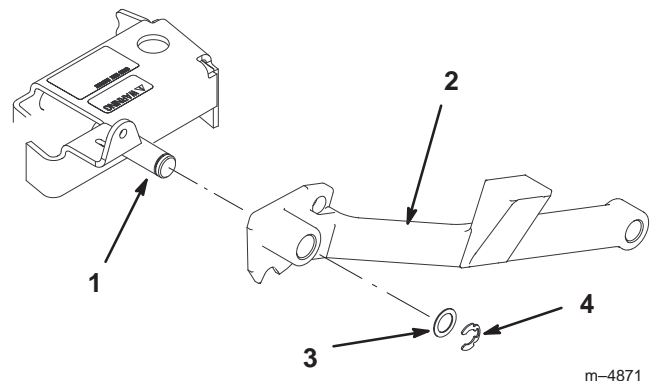

m-4871

**Figure 75**

- |             |                              |
|-------------|------------------------------|
| 1. Pin      | 3. Flat washer, 1-1/2 inches |
| 2. Push arm | 4. Retaining ring            |

4. Insert a pin punch into the push arm and carefully drive out the bushings (Fig. 76). Clean the inside of the push arm.
5. Use a hammer and flat plate to carefully drive new bushings into the end of push arm (Fig. 76).
6. Place push arm onto carrier frame pin and secure with a flat washer (1-1/2 inches) and retaining ring (Fig. 75).
7. Grease the fitting on the push arm using No. 2 general purpose lithium base or molybdenum base grease.

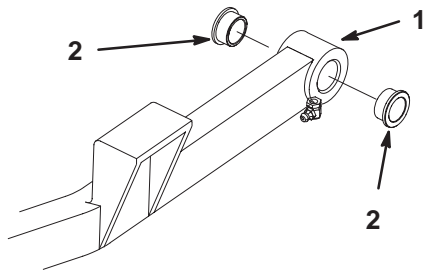
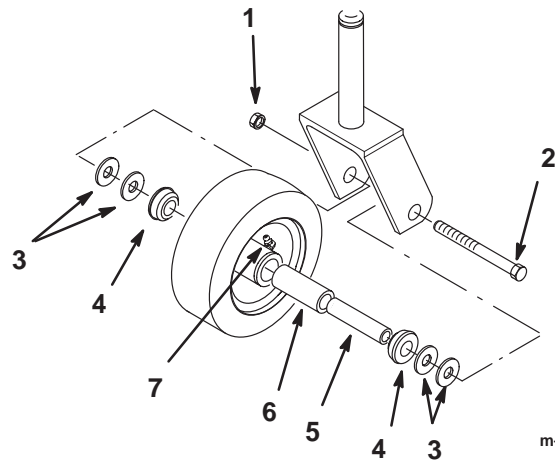

**Figure 76**

1. Push arm
2. Bushing

m-3284

6. Install the castor wheel into the castor fork and secure with the wheel bolt and locknut. Tighten the locknut until the spanner bushing bottoms against the inside of the castor forks (Fig. 77).
7. Grease the fitting on the castor wheel.



**Figure 77**

1. Locknut
2. Wheel Bolt
3. Washer
4. Bushing
5. Spanner Bushing
6. Roller Bearing
7. Grease fitting

m-3283

## Servicing the Castor Wheels and Tail Wheel Bearings

The castor wheels and tail wheel rotate on a roller bearing supported by a spanner bushing. If the bearing is kept well lubricated, wear will be minimal. Failure to keep the bearing well lubricated will cause rapid wear. A wobbly castor wheel usually indicates a worn bearing.

1. Remove the locknut and wheel bolt holding the castor wheel to the castor fork (Fig. 77).
2. Remove the washer and bushing, then pull the spanner bushing and roller bearing out of the wheel hub (Fig. 77).
3. Remove the other bushing from the wheel hub and clean any grease and dirt from the wheel hub (Fig. 77).
4. Inspect the roller bearing, bushings, spanner bushing and inside of the wheel hub for wear. Replace any defective or worn parts (Fig. 77).
5. To assemble, place one bushing into the wheel hub. Grease the roller bearing and spanner bushing and slide them into the wheel hub. Place the second bushing into the wheel hub (Fig. 77).

## Checking the Tire Pressure

Maintain the air pressure in the front and rear tires as specified. Uneven tire pressure can cause uneven cut. Check the pressure at the valve stem after every 50 operating hours or monthly, whichever occurs first (Fig. 78 and 79). Check the tires when they are cold to get the most accurate pressure reading.

Pressure: 83 kPa (12 psi) drive wheels  
 83 kPa (12 psi) tail wheel  
 345 kPa (45 psi) castor wheels

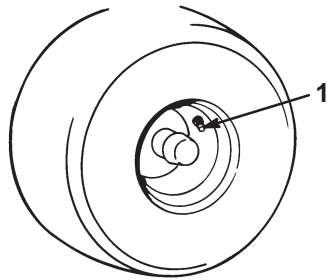

m-1872

**Figure 78**

1. Drive Wheel and Tail Wheel Valve Stem

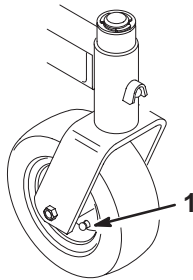

m-3281

**Figure 79**

1. Castor Wheel Valve Stem

## Servicing the Hydraulic System

### Checking the Hydraulic Fluid

Check the hydraulic fluid level before engine is first started and after every 8 operating hours.

Fluid Type: Mobil 1<sup>®</sup> TSW-50 synthetic oil or equivalent synthetic oil.

**Important** Use only oils specified. Other fluids could cause system damage.

Total System Capacity: 2.8 l (96 oz.)

1. Position machine on a level surface and set the parking brake.
2. Clean area around filler neck of hydraulic tank (Fig. 80).
3. Remove cap from filler neck. Look inside to check if there is fluid in the reservoir (Fig. 80).
4. If there is no fluid, add fluid to reservoir approximately a 6 mm (1/4 inches) below the top of baffle.
5. Run the machine 15 minutes to allow any air to purge out of the system and warm fluid.

6. Recheck level while fluid is warm. Add fluid to raise level to top of the baffle, if required.

**Note:** Fluid level should be to the top of the baffle when fluid is warm (Fig. 80).

7. Install cap on filler neck.

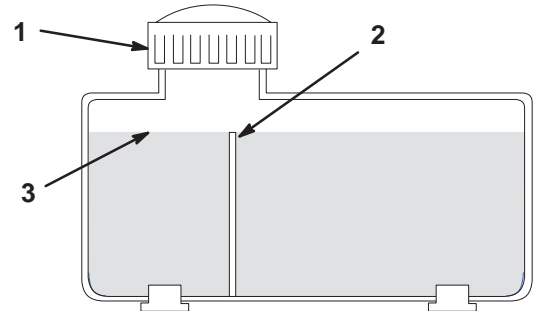

m-5279

**Figure 80**

1. Cap
2. Baffle
3. Fluid level—full

⚠
Warning
⚠

**Hydraulic fluid escaping under pressure can penetrate skin and cause injury.**

- If hydraulic fluid is injected into the skin it must be surgically removed within a few hours by a doctor familiar with this type of injury. Gangrene may result if this is not done.
- Keep body and hands away from pin hole leaks or nozzles that eject high pressure hydraulic fluid.
- Use cardboard or paper to find hydraulic leaks.
- Safely relieve all pressure in the hydraulic system before performing any work on the hydraulic system.
- Make sure all hydraulic fluid hoses and lines are in good condition and all hydraulic connections and fittings are tight before applying pressure to hydraulic system.

### Replacing the Hydraulic Filter

Change the hydraulic filter:

- After the first 8 operating hours
  - After every 200 operating hours
1. Position machine on a level surface, stop the engine, and remove key from ignition switch.

**Important** Do not substitute automotive oil filter or severe hydraulic system damage may result.

2. Remove hydro cap and temporarily cover opening with a plastic bag and rubber band to prevent all hydro fluid from draining out.
3. Place drain pan under filter, remove the old filter and wipe the filter adapter gasket surface clean (Fig. 81).

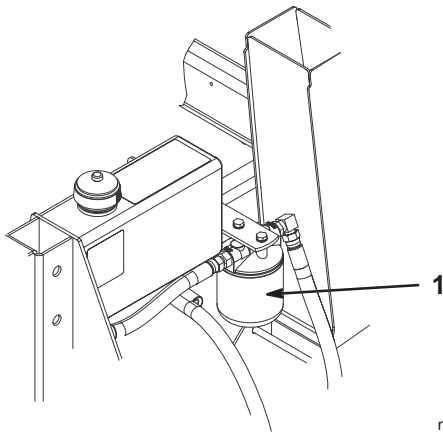

m-5284

**Figure 81**

1. Hydraulic filter

4. Apply a thin coat hydro fluid to the rubber gasket on the replacement filter (Fig. 82).
5. Install replacement hydraulic filter onto the filter adapter. Do not tighten.
6. Remove plastic bag from tank opening and allow filter to fill with hydro fluid.
7. When fluid overflows filter turn the oil filter clockwise until the rubber gasket contacts the filter adapter, then tighten the filter an additional 1/2 turn (Fig. 82).
8. Clean up any spilled fluid.
9. If there is no fluid, add fluid to reservoir approximately a 6 mm (1/4 inch) below the top of baffle.
10. Start engine and let run for about two minutes to purge air from the system. Stop the engine and check for leaks. If one or both wheels will not drive, refer Bleeding Hydraulic System, page 44.
11. Recheck level while fluid is warm. Add fluid to raise level to top of the baffle, if required. **Do not over fill.**

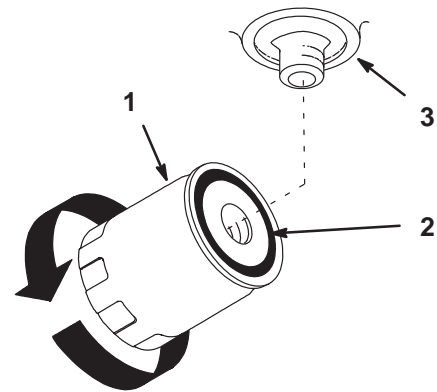

m-1256

**Figure 82**

1. Hydraulic filter
2. Gasket
3. Adapter

## Bleeding the Hydraulic System

The traction system is self bleeding, however, it may be necessary to bleed the system if fluid is changed or after work is performed on the system.

1. Raise front of the machine so wheels are off the ground and support with jack stands.
2. Start the engine and run at idle speed. Engage traction on one side and spin the wheel by hand.
3. When the wheel begins to spin on its own, keep it engaged until wheel drives smoothly. (minimum 2 minutes).
4. Check hydraulic fluid level as it drops and add as required to maintain proper level.
5. Repeat procedure on opposite wheel.

## Check the Hydraulic Lines

After every 100 operating hours, check hydraulic lines and hoses for leaks, loose fittings, kinked lines, loose mounting supports, wear, weather and chemical deterioration. Make necessary repairs before operating.



## Warning



Hydraulic fluid escaping under pressure can penetrate skin and cause injury.

- If hydraulic fluid is injected into the skin it must be surgically removed within a few hours by a doctor familiar with this type of injury. Gangrene may result if this is not done.
- Keep body and hands away from pin hole leaks or nozzles that eject high pressure hydraulic fluid.
- Use cardboard or paper to find hydraulic leaks.
- Safely relieve all pressure in the hydraulic system before performing any work on the hydraulic system.
- Make sure all hydraulic fluid hoses and lines are in good condition and all hydraulic connections and fittings are tight before applying pressure to hydraulic system.

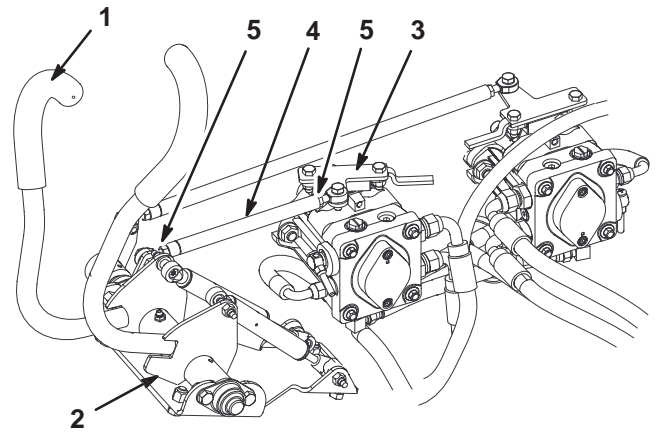

m-5285

Figure 83

- |                         |                |
|-------------------------|----------------|
| 1. Motion control lever | 4. Control rod |
| 2. Forward stop         | 5. Jam nut     |
| 3. Pump control plate   |                |

## Adjusting the Motion Controls

If motion control levers do not align, adjustment is required. Adjust each rod separately.

1. Loosen jam nuts on pump control rod (Fig. 83).
2. Push and firmly hold motion control lever against forward stop (Fig. 83).
3. Rotate pump control rod until pump control plate is in the full forward position (Fig. 83). Motion control lever will lift off forward stop.

**Important** Hold motion control lever firmly against forward stop to determine when pump control reaches stop.

4. Rotate control rod 1 turn in reverse direction and tighten jam nuts (Fig. 83).

**Important** Motion control lever must contact forward stop before pump contacts internal stop or pump damage may occur.

5. If motion control levers do not line up in neutral, identify control rod of handle closer to the seat. Rotate to lengthen this control rod a little. Tighten jam nuts.

## Replacing the Power Take Off (PTO) Belt

Check power take off (PTO) belt for wear after every 50 hours of operation.

1. Remove the bumper and guard that protects the PTO belt and pulleys (Fig. 84).

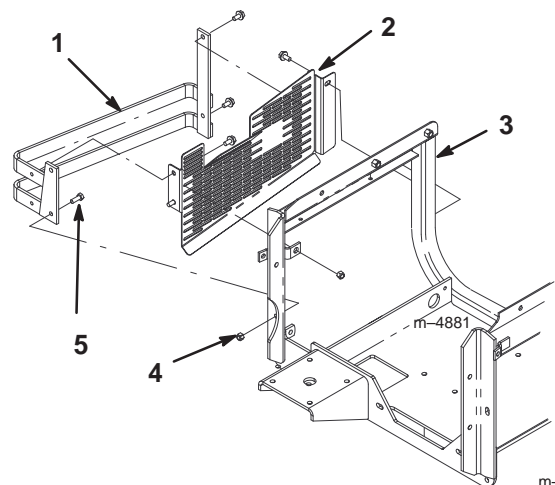

m-4881

Figure 84

- |           |         |
|-----------|---------|
| 1. Bumper | 4. Nut  |
| 2. Guard  | 5. Bolt |
| 3. Frame  |         |

- Using a rag or thickly padded glove, hold spring loaded idler against belts and pull spring down to remove from idler stud (Fig. 85).
- Lower idler to relax tension on PTO belt and remove belt from gear box pulley (Fig. 85).
- Remove clutch stop mounting bolts and unplug clutch wire harness (Fig. 85). Remove belt over clutch.

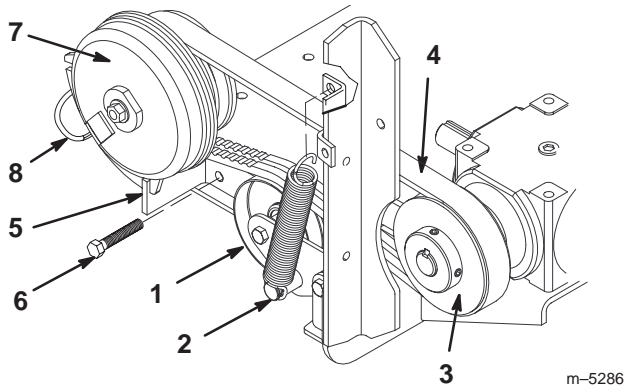

**Figure 85**

- |                    |                                |
|--------------------|--------------------------------|
| 1. Idler           | 6. Bolt                        |
| 2. Spring          | 7. Clutch                      |
| 3. Gear box pulley | 8. Clutch electrical connector |
| 4. PTO belt        |                                |
| 5. Clutch stop     |                                |

- Install new PTO belt over clutch and route around gearbox pulley and above spring loaded idler (Fig. 86).
- Hold spring loaded idler against belts and pull spring down to install on idler stud (Fig. 85).
- Install clutch stop (Fig. 85). Tighten mounting bolts securely.
- Plug clutch wire into wire harness.

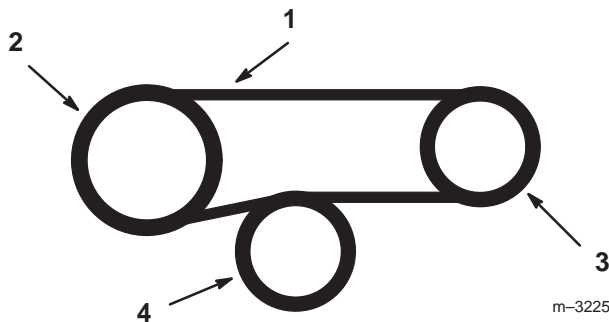

**Figure 86**

- |                  |                        |
|------------------|------------------------|
| 1. PTO belt      | 3. Gearbox pulley      |
| 2. Clutch pulley | 4. Spring loaded idler |

- Install bumper and guard that protects PTO belt (Fig. 84).

## Replacing the Traction Belt

Check traction drive belt for wear after every 50 hours of operation.

- Remove PTO belt; refer to Replacing Power Take Off (PTO) Belt on page 45.
- Push spring loaded idler down and remove traction belt from the engine, fixed idler and hydro pump pulleys (Fig. 87). Remove belt over clutch.
- Install new belt over clutch and around engine, fixed idler and hydro pump pulleys (Fig. 87).
- Push spring loaded idler down and align below traction belt. Release pressure on spring loaded idler (Fig. 87).
- Install PTO belt; refer to Replacing Power Take Off (PTO) Belt.

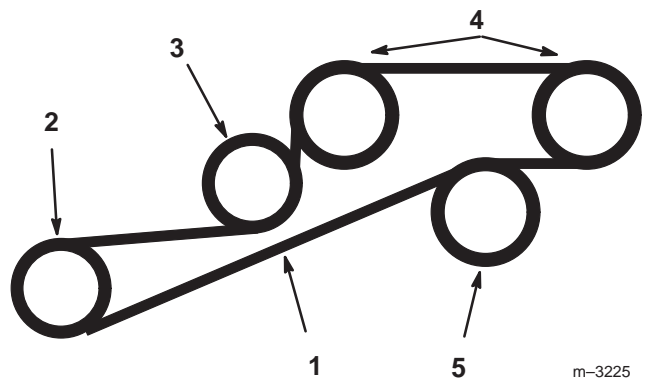

**Figure 87**

- |                       |                        |
|-----------------------|------------------------|
| 1. Traction belt      | 4. Hydro pump pulley   |
| 2. Engine pulley      | 5. Spring loaded idler |
| 3. Fixed idler pulley |                        |

## Replacing the Blower Belt

Squealing when the belt is rotating, blower slipping causing frequent clogging of chute and blower, frayed belt edges, burn marks and cracks are all signs of a worn blower belt. Replace the blower belt if any of these conditions are evident.

- Stop the engine, remove the key and disconnect the spark plug wire(s) from the spark plug(s).
- Push up on the spring loaded idler arm behind left hand traction tire to relax pressure on blower belt (Fig. 88). Lock into frame slot.
- Remove worn blower belt.
- Install new blower belt around PTO gearbox and blower pulleys. Then release spring loaded idler arm and place belt above idler pulley (Fig. 88).
- Check that belt aligns with PTO box, blower and idler pulleys (Fig. 88).

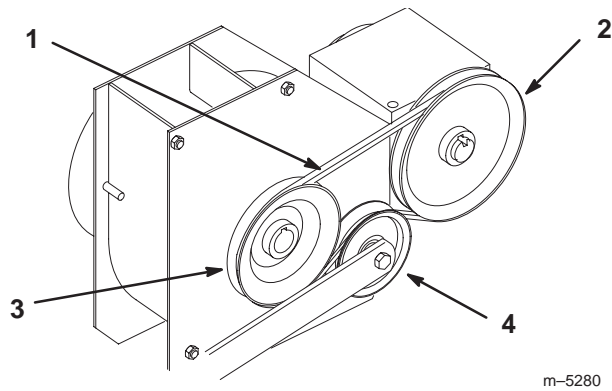

**Figure 88**

- |                       |                  |
|-----------------------|------------------|
| 1. Blower belt        | 3. Blower pulley |
| 2. PTO Gearbox pulley | 4. Idler pulley  |

## Turning Engine Lift Hook

Turn the engine lift hook if the engine is to be lifted. The engine lift hook is positioned to allow clearance for the air cleaner hose.

1. Locate on engine the lift hook in figure 89.
2. Remove the lift hook from engine. Rotate lift hook 180 degrees and reinstall.
3. Use the engine lift hook.
4. Rotate lift hook 180 degrees and reinstall to its original position.

**Important** Return lift hook to original position after engine has been reinstalled.

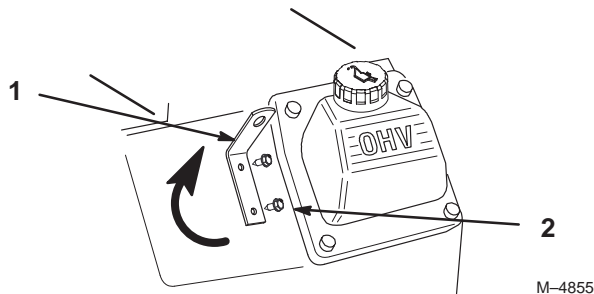

**Figure 89**

- |                     |           |
|---------------------|-----------|
| 1. Engine Lift Hook | 2. Screws |
|---------------------|-----------|

## Servicing the Fuse

### Service Interval/Specification

The electrical system is protected by fuses. It requires no maintenance, however, if a fuse blows check component/circuit for malfunction or short.

Fuse: Main F1-30 amp, blade-type  
 Alternator F2-25 amp, blade-type  
 Safety Interlock and Clutch F3-15 amp, blade-type

1. Remove dash panel screws to gain access to fuse holder (Fig. 90).
2. To replace fuses pull out on the fuse to remove it (Fig. 90).

**Important** Do not install fuses of greater capacity as call out above. It could cause electrical system damage.

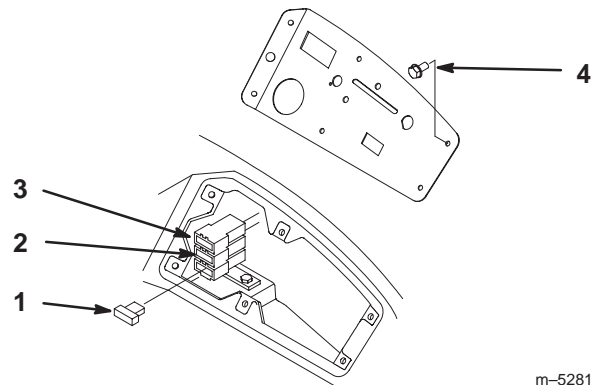

**Figure 90**

- |                      |                                       |
|----------------------|---------------------------------------|
| 1. Main-30 amp       | 3. Safety interlock and clutch-15 Amp |
| 2. Alternator-25 amp | 4. Screw                              |

## Servicing the Battery



### Warning



Battery posts, terminals, and related accessories contain lead and lead compounds, chemicals known to the State of California to cause cancer and reproductive harm. *Wash hands after handling.*

### Checking Electrolyte Level

1. With the engine off, open the hood to locate the battery.

2. Look at the side of the battery. The electrolyte must be up to the **upper** line (Fig. 91). Do not allow the electrolyte to get below the **lower** line (Fig. 91).
3. If the electrolyte is low, add the required amount of distilled water; refer to Adding Water to the Battery, page 49.

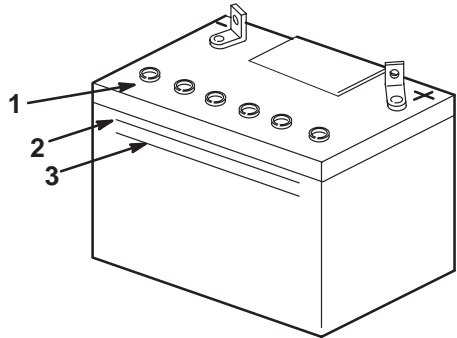

m-5004

**Figure 91**

1. Filler caps
2. **Upper** line
3. **Lower** line



## Danger



**Battery electrolyte contains sulfuric acid which is a deadly poison and causes severe burns.**

- **Do not drink electrolyte and avoid contact with skin, eyes or clothing. Wear safety glasses to shield your eyes and rubber gloves to protect your hands.**
- **Fill the battery where clean water is always available for flushing the skin.**
- **Follow all instructions and comply with all safety messages on the electrolyte container.**

## Installing the Battery



### Warning



**Battery terminals or metal tools could short against metal machine components causing sparks. Sparks can cause the battery gasses to explode, resulting in personal injury.**

- **When removing or installing the battery, do not allow the battery terminals to touch any metal parts of the machine.**
- **Do not allow metal tools to short between the battery terminals and metal parts of the machine.**

1. Position battery in tray with terminal posts toward the engine (Fig. 92).
2. First, install the positive (red) battery cable to positive (+) battery terminal.
3. Then install negative battery cable and ground wire to the negative (-) battery terminal.
4. Secure cables with 2 bolts (1/4 x 3/4 inch), 2 washers (1/4 inch), and 2 locknuts (1/4 inch) (Fig. 92).
5. Slide the red terminal boot onto the positive (red) battery post.
6. Position support rods in mounting holes (Fig. 92). Secure battery with 2 support rods, a battery clamp and 2 wing nuts (1/4 inch). Tighten wing nuts so battery is held securely in position and will not slide. **Do not overtighten.**

**Important** Route cables so they do not contact metal edges, frame members, or tail wheel.

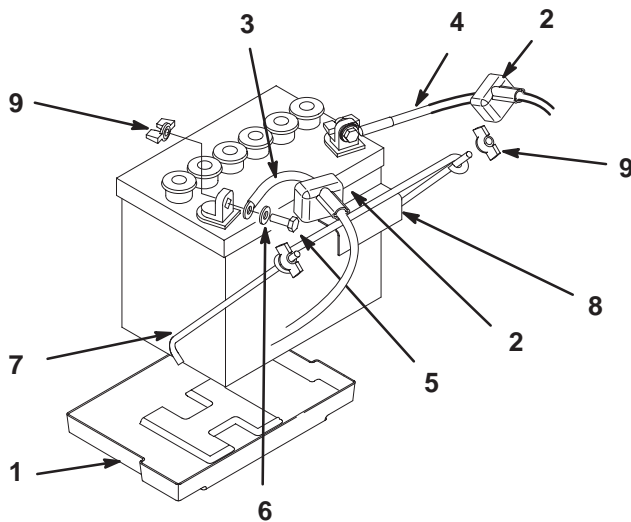

m-4886

**Figure 92**

- |                           |                        |
|---------------------------|------------------------|
| 1. Battery tray           | 6. Washer, 1/4 inch    |
| 2. Terminal boot          | 7. Battery support rod |
| 3. Positive battery cable | 8. Battery clamp       |
| 4. Negative battery cable | 9. Wing nut, 1/4 inch  |
| 5. Bolt, 1/4 x 3/4 inch   |                        |

## Removing the Battery

⚠
Warning
⚠

**Incorrect battery cable routing could damage the machine and cables causing sparks. Sparks can cause the battery gasses to explode, resulting in personal injury.**

- **Always *Disconnect* the negative (black) battery cable before disconnecting the positive (red) cable.**
- **Always *Reconnect* the positive (red) battery cable before reconnecting the negative (black) cable.**

1. Disengage the power take off (PTO), set the parking brake, and turn the ignition key to off. Remove the key.
2. First disconnect the negative battery cable and ground wire from the negative (-) battery terminal (Fig. 92).
3. Slide the red terminal boot off the positive (red) battery terminal. Then remove positive (red) battery cable (Fig. 92).
4. Remove both wing nuts (1/4 inch) securing the battery clamp and support rods (Fig. 92).
5. Remove the battery.

## Adding Water to the Battery

The best time to add distilled water to the battery is just before you operate the machine. This lets the water mix thoroughly with the electrolyte solution.

1. Remove the battery from the machine.
2. Clean the top of the battery with a paper towel.

**Note:** Never fill the battery with distilled water while the battery installed in the machine. Electrolyte could be spilled on other parts and cause corrosion.

3. Remove the vent caps from the battery (Fig. 91).
4. Slowly pour distilled water into each battery cell until the level is up to the **upper** line (Fig. 91) on the battery case.

**Important** Do not overfill the battery because electrolyte (sulfuric acid) can cause severe corrosion and damage to the chassis.

5. Wait five to ten minutes after filling the battery cells. Add distilled water, if necessary, until the electrolyte level is up to the **upper** line (Fig. 91) on the battery case.

6. Reinstall battery vent caps.

## Charging the Battery

⚠
Warning
⚠

**Charging the battery produces gasses that can explode.**

**Never smoke near the battery and keep sparks and flames away from battery.**

**Important** Always keep the battery fully charged (1.265 specific gravity). This is especially important to prevent battery damage when the temperature is below 32°F (0°C).

1. Remove the battery from the chassis; refer to Removing the Battery, page 49.
2. Check the electrolyte level; refer to Checking Electrolyte Level, page 47.
3. Make sure the filler caps are installed in battery. Charge battery for 10 to 15 minutes at 25 to 30 amps or 30 minutes at 4–6 amps.
4. When the battery is fully charged, unplug the charger from the electrical outlet, then disconnect the charger leads from the battery posts (Fig. 93).

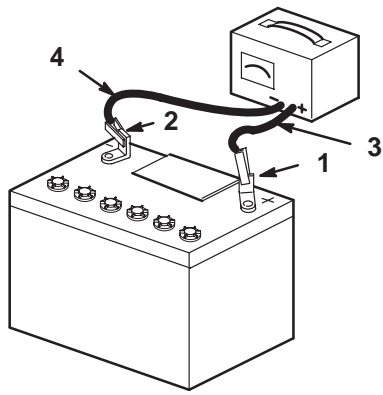

m-4970

**Figure 93**

- |                          |                           |
|--------------------------|---------------------------|
| 1. Positive Battery Post | 3. Red (+) Charger Lead   |
| 2. Negative Battery Post | 4. Black (-) Charger Lead |

5. Install the battery in the machine and connect the battery cables; refer to Installing the Battery on page 48.

**Note:** Do not run the machine with the battery disconnected, electrical damage may occur.

## Cleaning the Hopper Screens

For best clipping collection, maximum air flow through the hopper is required. To provide maximum air flow, the hopper screens must be kept clean.

1. To clean the hopper screens dump the hopper to remove grass clippings.
2. With the door open, remove the knobs at the upper front of the hopper and slide the screens out the rear of the hopper (Fig. 94).
3. Clean the screen by brushing off with your hand, blowing with compressed air or spraying with a stream of water.
4. Replace the screens and secure with knobs (Fig. 94). Close and latch the hopper door.

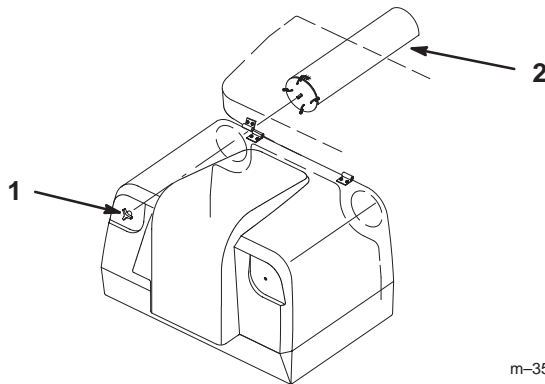

m-3546

**Figure 94**

- |         |           |
|---------|-----------|
| 1. Knob | 2. Screen |
|---------|-----------|

## Cleaning the Hopper Full Sensor

The hopper full sensor, inside the top right side of the hopper, detects a beam of light from the transmitter to the receiver. If the light beam is blocked the sensor buzzer sounds. If the lenses are covered with clippings or debris it may give false hopper full signals and needs to be cleaned.

**Note:** There are two different positions the hopper full sensors can be mounted. The lower position will signal the hopper full alarm earlier and prevent plugging of the chute and blower.

1. To clean the hopper full sensor dump the hopper to remove grass clippings.
2. With the door open, wipe off the lenses of both the transmitter and receiver with a soft cloth or paper towel (Fig. 95).
3. To test the hopper full sensor for proper operation turn the ignition key and PTO switch to on, but do not start the engine. Place a piece of heavy cardboard in front of the transmitter to block the light beam (Fig. 95). The alarm buzzer should sound.

**Note:** Do not use your hand to test for proper sensor operation as the light beam may pass through or around your hand and not properly activate the sensor.

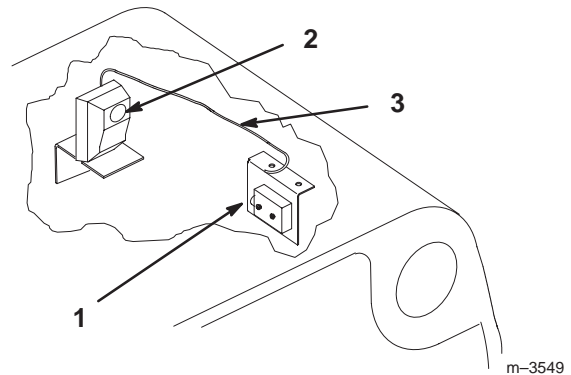

m-3549

**Figure 95**

- |                |         |
|----------------|---------|
| 1. Transmitter | 3. Wire |
| 2. Receiver    |         |

**Note:** Make sure the wire between receiver and transmitter is tight. It can collect debris and give a false hopper full signal.

# Wiring Diagram

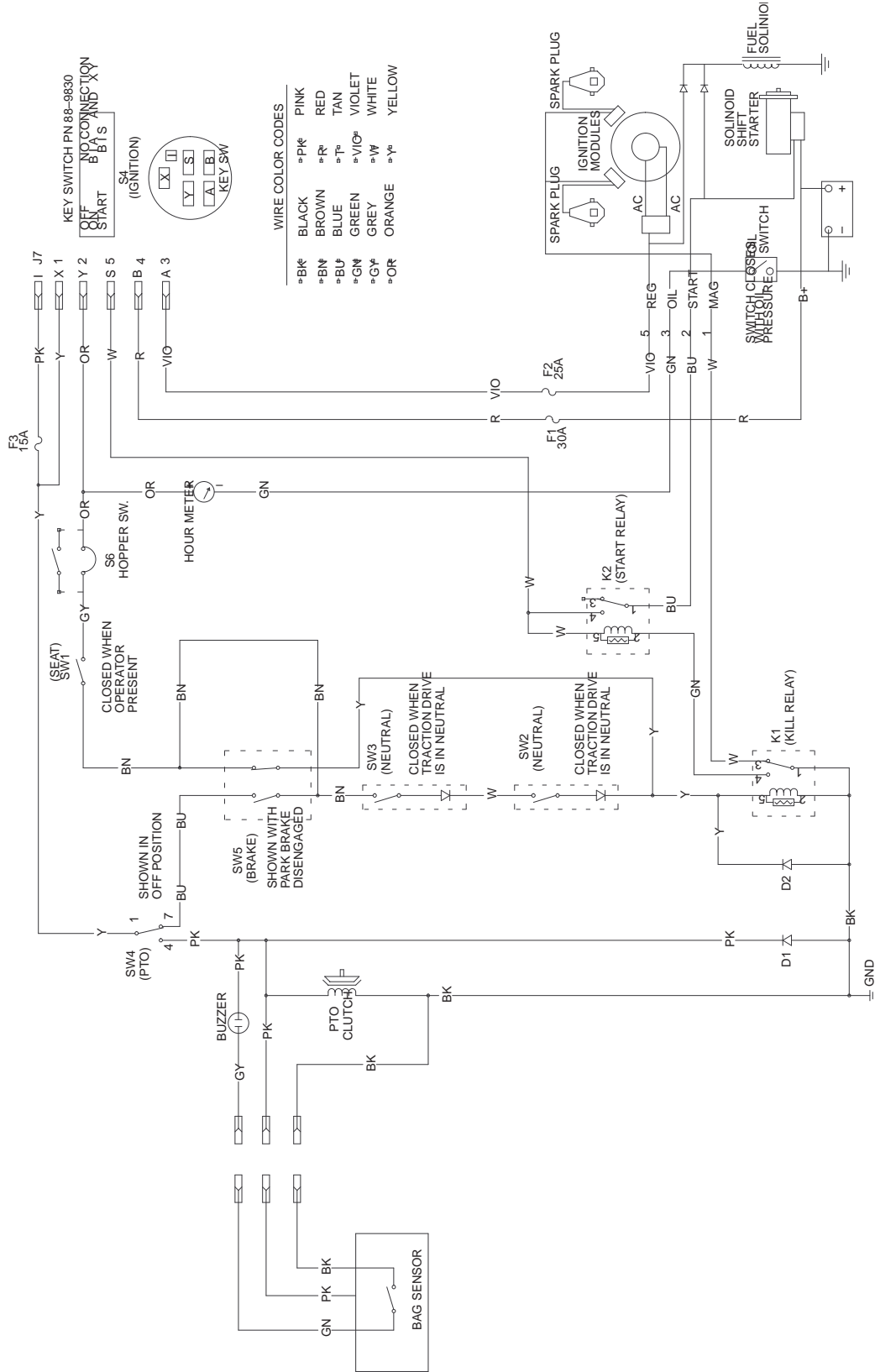

# Hydraulic Diagram

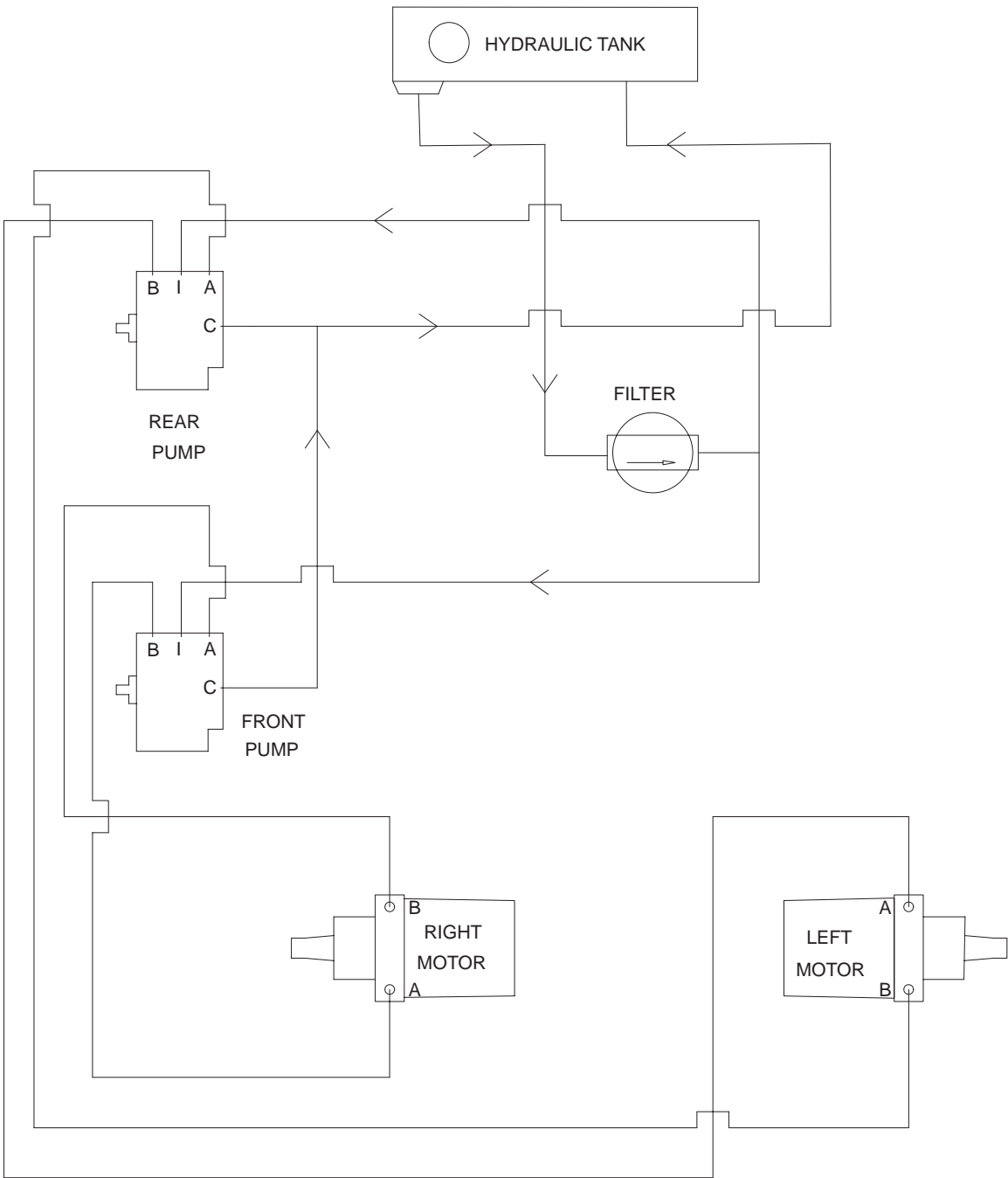

## Cleaning and Storage

1. Disengage the power take off (PTO), set the parking brake and turn the ignition key to off. Remove the key.
2. Remove grass clippings, dirt, and grime from the external parts of the entire machine, especially the engine. Clean dirt and chaff from the outside of the engine's cylinder head fins and blower housing.
3. Clean any dirt and chaff from the mower, chute, blower and hopper.
4. Scrape any heavy buildup of grass and dirt from the mower, chute, blower and hopper, then wash with a garden hose.

**Important** You can wash the machine with mild detergent and water. Do not pressure wash the machine. Avoid excessive use of water, especially near the control panel, engine, hydraulic pumps and motors.

5. Check the condition of the blades. Refer to Servicing the Cutting Blades on page 29.
6. Service the air cleaner; refer to Servicing the Air Cleaner, page 32.
7. Grease the machine; refer to Greasing and Lubricating page 38.
8. Change the crankcase oil; refer to Servicing the Engine Oil, page 34.
9. Change the hydraulic fluid; refer to Servicing the Hydraulic System, page 43.
10. For long-term storage (more than 90 days) add stabilizer/conditioner additive to fuel in the tank.
  - A. Run engine to distribute conditioned fuel through the fuel system (5 minutes).
  - B. Stop engine, allow to cool and drain the fuel tank; refer to Servicing the Fuel Tank, page 37.
  - C. Restart engine and run until it stops. Repeat, on choke until engine will not restart.
  - D. Dispose of fuel properly. Recycle as per local codes.

**Note:** Do not store stabilizer/conditioned gasoline over 90 days.

11. Remove the spark plug(s) and check its condition; refer to Servicing the Spark Plug, page 35. With the spark plug(s) removed from the engine, pour two tablespoons of engine oil into the spark plug hole. Now use the starter to crank the engine and distribute the oil inside the cylinder. Install the spark plug(s). Do not install the wire on the spark plug(s).
12. Check the condition of all belts.
13. Check the tire pressure; refer to Checking the Tire Pressure, page 42.
14. Disconnect the negative battery cable. Clean the battery and battery terminals. Check the electrolyte level and charge it fully; refer to Servicing the Battery on page 47. Leave the negative battery cable disconnected from the battery during storage.

**Important** The battery must be fully charged to prevent it from freezing and being damaged at temperatures below 32°F (0°C). A fully charged battery can be stored one winter season without recharging.

15. Check and tighten all bolts, nuts, and screws. Repair or replace any part that is damaged or defective.
16. Paint all scratched or bare metal surfaces. Paint is available from your Authorized Service Dealer.
17. Store the machine in a clean, dry garage or storage area. Remove the key from the ignition switch and keep it in a memorable place. Cover the machine to protect it and keep it clean.

# Troubleshooting

PROBLEM	POSSIBLE CAUSES	CORRECTIVE ACTION
Starter does not crank	<ol style="list-style-type: none"> <li>1. Power take off (PTO) is ENGAGED.</li> <li>2. Parking brake is not on.</li> <li>3. Motion control levers are not in neutral.</li> <li>4. Battery is dead.</li> <li>5. Electrical connections are corroded or loose.</li> <li>6. Fuse is blown.</li> <li>7. Relay or switch is defective.</li> </ol>	<ol style="list-style-type: none"> <li>1. Move power take off (PTO) to DISENGAGED.</li> <li>2. Set parking brake.</li> <li>3. Move motion control levers into neutral.</li> <li>4. Charge the battery.</li> <li>5. Check electrical connections for good contact.</li> <li>6. Replace fuse.</li> <li>7. Contact Authorized Service Dealer.</li> </ol>
Engine will not start, starts hard, or fails to keep running.	<ol style="list-style-type: none"> <li>1. Fuel tank is empty.</li> <li>2. Choke is not ON.</li> <li>3. Air cleaner is dirty.</li> <li>4. Spark plug wires is loose or disconnected.</li> <li>5. Spark plugs are pitted, fouled, or gap is incorrect.</li> <li>6. Dirt in fuel filter.</li> <li>7. Dirt, water, or stale fuel is in fuel system.</li> </ol>	<ol style="list-style-type: none"> <li>1. Fill fuel tank with gasoline.</li> <li>2. Move choke lever to ON.</li> <li>3. Clean or replace air cleaner element.</li> <li>4. Install wires on spark plug.</li> <li>5. Install new, correctly gapped spark plugs.</li> <li>6. Replace fuel filter.</li> <li>7. Contact Authorized Service Dealer.</li> </ol>
Engine loses power.	<ol style="list-style-type: none"> <li>1. Engine load is excessive.</li> <li>2. Air cleaner is dirty.</li> <li>3. Oil level in crankcase is low.</li> <li>4. Cooling fins and air passages under engine blower housing are plugged.</li> <li>5. Spark plugs are pitted, fouled, or gap is incorrect.</li> <li>6. Dirt in fuel filter.</li> <li>7. Dirt, water, or stale fuel is in fuel system.</li> </ol>	<ol style="list-style-type: none"> <li>1. Reduce ground speed.</li> <li>2. Clean air cleaner element.</li> <li>3. Add oil to crankcase.</li> <li>4. Remove obstruction from cooling fins and air passages.</li> <li>5. Install new, correctly gapped spark plugs.</li> <li>6. Replace fuel filter.</li> <li>7. Contact Authorized Service Dealer.</li> </ol>
Engine overheats.	<ol style="list-style-type: none"> <li>1. Engine load is excessive.</li> <li>2. Oil level in crankcase is low.</li> <li>3. Cooling fins and air passages under engine blower housing are plugged.</li> </ol>	<ol style="list-style-type: none"> <li>1. Reduce ground speed.</li> <li>2. Add oil to crankcase.</li> <li>3. Remove obstruction from cooling fins and air passages.</li> </ol>

PROBLEM	POSSIBLE CAUSES	CORRECTIVE ACTION
Abnormal vibration.	<ol style="list-style-type: none"> <li>1. Engine mounting bolts are loose.</li> <li>2. Loose engine pulley, idler pulley, or blade pulley.</li> <li>3. Engine pulley is damaged.</li> </ol>	<ol style="list-style-type: none"> <li>1. Tighten engine mounting bolts.</li> <li>2. Tighten the appropriate pulley.</li> <li>3. Contact Authorized Service Dealer.</li> </ol>
Machine does not drive.	<ol style="list-style-type: none"> <li>1. Parking brake is on.</li> <li>2. Traction belt is worn, loose or broken.</li> <li>3. Traction belt is off pulley.</li> <li>4. Hydro fluid level low.</li> </ol>	<ol style="list-style-type: none"> <li>1. Move parking brake to off.</li> <li>2. Contact Authorized Service Dealer.</li> <li>3. Contact Authorized Service Dealer.</li> <li>4. Add hydro fluid to reservoir.</li> </ol>

