



14-38HXLE

Wheel Horse[®] Lawn Tractor

Model No. 71245-23000001 and Up

Parts Catalog

Ordering Replacement Parts

To order replacement parts, please supply: the part number, the quantity, and the description of each part desired.

Understanding Reference Numbers

Each identified part in an illustration has a reference number. The reference number for a part also appears in the parts list, along with other information about the part.

This catalog uses two special reference number formats, one to indicate parts in a service assembly and another to indicate the quantity of a given part in an illustration.

Service Assembly Reference Numbers

Parts in service assemblies have reference numbers in the form **a:b**. The **a** represents the reference number of the entire service assembly and the **b** represents a sequential number unique to each part within the service assembly.

For example, a wheel assembly might be identified by reference number **6**, the tire by **6:1**, the valve by **6:2**, and the wheel by **6:3**. When you order the assembly identified by reference number **6**, you receive all parts identified by reference numbers **6:1**, **6:2**, and **6:3**. However, you may also order any part individually.

Reference numbers of this type appear in illustrations and in part lists.

Reference Numbers Indicating Quantity

In an illustration, if a reference number indicates more than one part, the reference number has the form **nX y**. The **n** represents the quantity of the part, the **X** is the multiplication symbol, and the **y** represents the reference number.

For example, in an illustration, the reference number **2X 37** means that two of the parts identified by reference number **37** are indicated.

Contents

Description	Page	Description	Page
Frame and Body Assembly	3	Crankshaft Assembly	
Hood and Tower Assembly	4	Engine Briggs and Stratton Model	
Rear Body and Seat Assembly	5	280H07-0160-E1	24
Steering Assembly	6	Crankcase Assembly	
Fixed Steering Assembly	7	Engine Briggs and Stratton Model	
Engine Assembly	8	280H07-0160-E1	25
Traction Clutching Assembly	9	Oil Filter, Tube and Pump Assembly	
Rear Wheel and Tire Assembly	10	Engine Briggs and Stratton Model	
Hydro Transaxle Assembly	11	280H07-0160-E1	26
Hydro Transaxle Control Assembly	12	Carburetor Assembly	
38in Deck Assembly	13	Engine Briggs and Stratton Model	
38in Deck Blade Drive and Braking Assembly ..	14	280H07-0160-E1	27
38in Deck Engagement Assembly	15	Governor Assembly	
Height of Cut Assembly	16	Engine Briggs and Stratton Model	
Electrical Assembly	17	280H07-0160-E1	28
Housing and Bearing Assembly	18	Blower Housing Assembly	
Gear Assembly	19	Engine Briggs and Stratton Model	
Axle Assembly	20	280H07-0160-E1	29
Electric Schematic	21	Starter Assembly	
Cylinder Assembly		Engine Briggs and Stratton Model	
Engine Briggs and Stratton Model		280H07-0160-E1	30
280H07-0160-E1	22	Gasket Assembly	
Cylinder Head Assembly		Engine Briggs and Stratton Model	
Engine Briggs and Stratton Model		280H07-0160-E1	31
280H07-0160-E1	23	Carburetor Overhaul Kit Assembly	
		Engine Briggs and Stratton Model	
		280H07-0160-E1	32

Part Description Abbreviations

Part descriptions in this catalog may include the following abbreviations.

Abbreviation	Meaning	Abbreviation	Meaning
AR	as required	HYD	hydraulic
ASM	assembly	INC	incorporated
CARR	carriage	LH	left hand
DEG	degrees	NI	nylon insert
FH	flat head	PPH	Phillips pan head
GA	gauge	PTH	Phillips truss head
HF	hex flange	PTO	power take off
HH	hex head	RH	right hand
HHF	hex head flange	SFH	slotted fillister head
HLH	hex lag head	SHH	slotted hex head
HJ	hex jam	SQH	square head
HOC	height-of-cut	SHWH	slotted hex washer head
HS	hex socket	SPH	slotted pan head
HSBH	hex socket button head	SRH	slotted round head
HSFH	hex socket flat head	STD	standard
HSH	hex socket head	TAP	self tapping
HWH	hex washer head	TTH	Torx truss head
HWHTF	hex washer head thread forming	WH	wing head

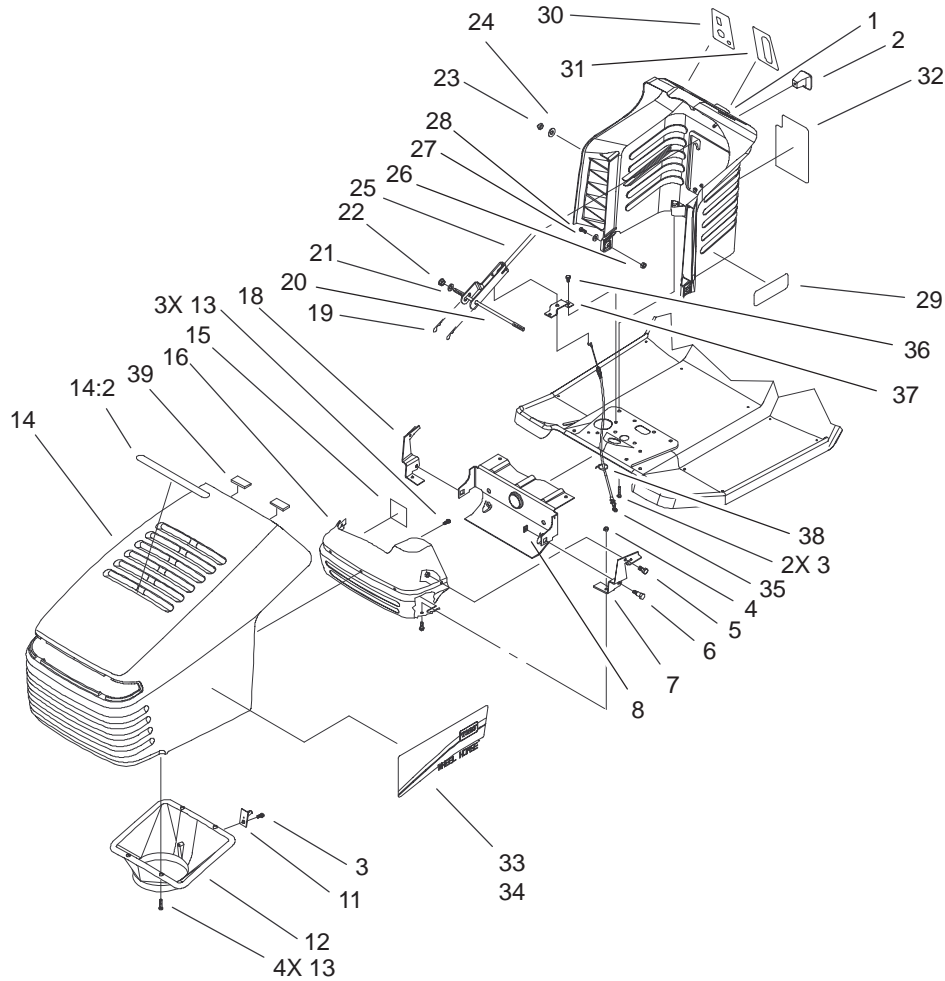

Sheet No.:3

Hood and Tower Assembly

Ref. No.	Part No.	Qty.	Description
1	99-1947	1	Tower-Steering
2	94-5565	1	Knob-Shift
3	46-8091	3	Screw-HWH
4	3296-42	4	Nut-Lock, NI
5	321-2	4	Screw-HH
6	28-0540	2	Bolt-Shoulder
7	88-6050-03	1	Bracket-Hinge, LH
8	3290-496	2	Nut-Retainer
11	94-1984	1	Latch-Pin
12	93-3891	1	Duct-Hood Air
13	46-8090	7	Screw-Plastite
14	93-3819	1	Hood-W/Decal, Toro
14:2	92-5748	1	Decal-Air Duct, Toro
15	92-5782	3	Tape-Foil
16	93-3864-03	1	Shield-Heat
18	88-6040-03	1	Bracket-Hinge, RH
19	3290-307	2	Pin-Hair
20	100-7401	1	Rod-Tower, Pivot
21	3256-24	2	Washer-Flat
22	3218-3	2	Nut-Jam
23	100-7402	2	Nut-Cap
24	100-7403	2	Washer-Flat
25	88-5190-03	1	Lever-Deck, Engage
26	3296-29	2	Nut-Lock, NI
27	3256-23	2	Washer-Flat
28	322-3	2	Screw-HH

Ref. No.	Part No.	Qty.	Description
29	106-6418	2	Decal-Tower 1438
30	99-8142	1	Decal-Ignition
31	92-5730	1	Decal-Throttle
32	93-6673	1	Decal-Deck, Engage
33	105-2497	1	Decal-Hood, LH
34	105-2496	1	Decal-Hood, RH
35	99-6837	1	Deck Cable ASM
36	9266714	2	Screw-HWH
37	93-3849	1	Bracket-Upper, Cable
38	614249	1	Strap-Tie
39	94-1980	2	Foam-Hood

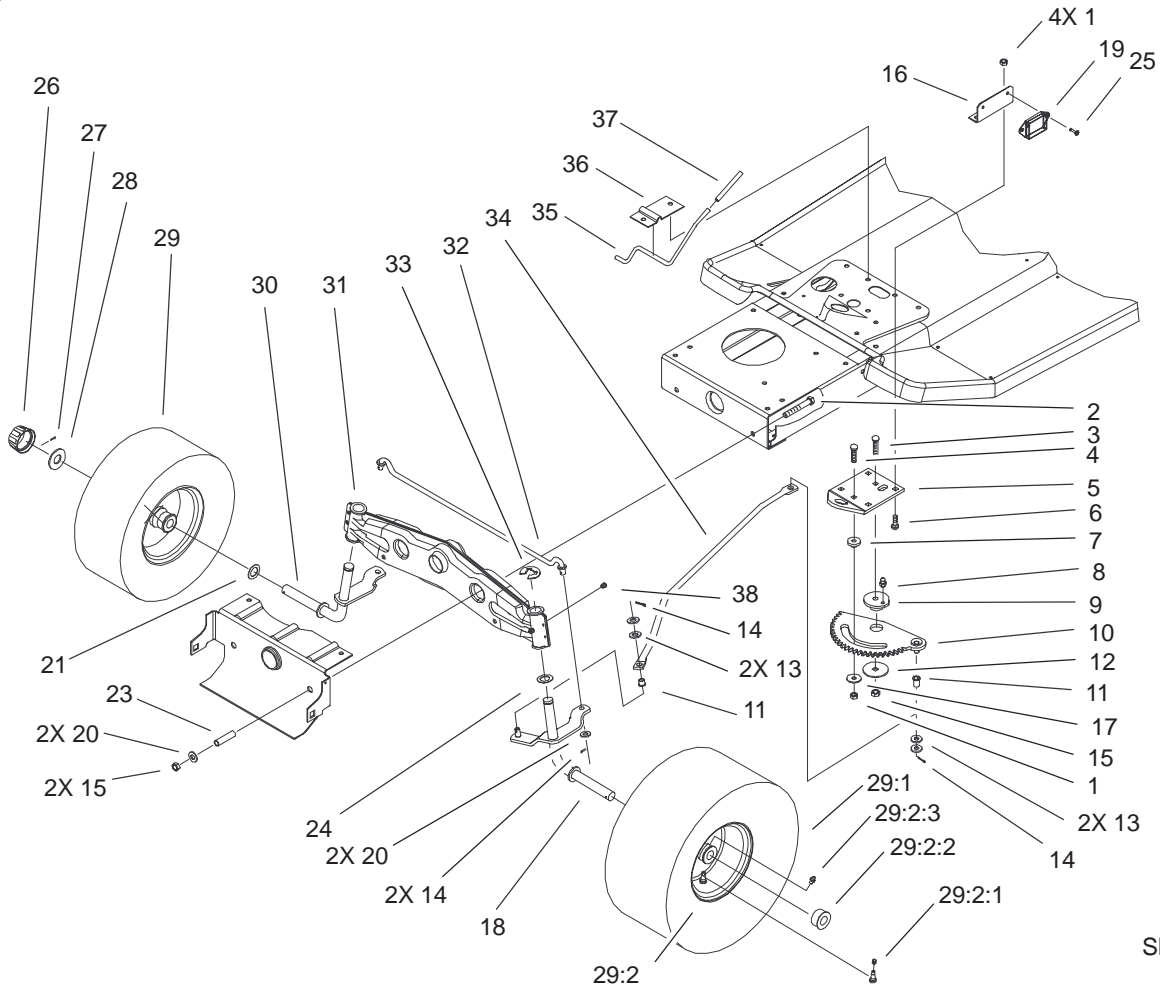

Sheet No.:5

Steering Assembly

Ref. No.	Part No.	Qty.	Description
1	3296-29	5	Nut-Lock, NI
2	323-13	2	Screw-HH
3	3231-4	1	Screw-CARR
4	3230-3	1	Screw-CARR
5	88-5130-03	1	Bracket-Steering Rack
6	3230-2	4	Bolt-CARR
7	88-5010	1	Spacer-Steering, Rack
8	302-26	1	Fitting-Grease
9	88-4670	1	Bushing-Eccentric
10	88-5200	1	Rack-Steering
11	52-2891	2	Bushing-Link, Steering
12	111419	1	Washer-Bearing
13	3256-25	4	Washer-Flat
14	3272-10	4	Pin-Cotter
15	3296-39	3	Nut-Lock, NI
16	99-2956-03	1	Bracket-Module
17	5-4460	1	Washer-Pivot
18	92-7890-03	1	Spindle-LH
19	99-3700	1	Module
20	3256-24	4	Washer-Flat
21	3-6498	4	Washer-Thrust
23	88-5470	2	Spacer-Front, Axle
24	3-6498	2	Washer-Thrust

Ref. No.	Part No.	Qty.	Description
25	9266714	2	Screw-HWH
26	61-9780	2	Cap-Hub
27	3272-12	2	Pin-Cotter
28	28-2480	2	Washer
☆29		2	Front Wheel&tire ASM
29:1	99-2988	1	Tire
29:2	88-4370	1	Rim ASM
29:2:1	232-27	1	Stem-Valve
29:2:2	88-4400	2	Bearing-Wheel
29:2:3	302-5	1	Fitting-Grease
*	232-39	1	Tube
30	92-7889-03	1	Spindle-RH
31	99-6844-03	1	Axle-Front
32	88-5380	1	Tie Rod-Steering
33	32151-48	2	E-Ring
34	88-4830	1	Link-Drag
35	88-5510	1	Rod-Parking, Brake
36	88-5520-03	1	Bracket-Parking, Brake
37	88-0890	1	Grip-Bag, Handle
38	302-5	2	Fitting-Grease

☆ Not serviced separately

* Not illustrated

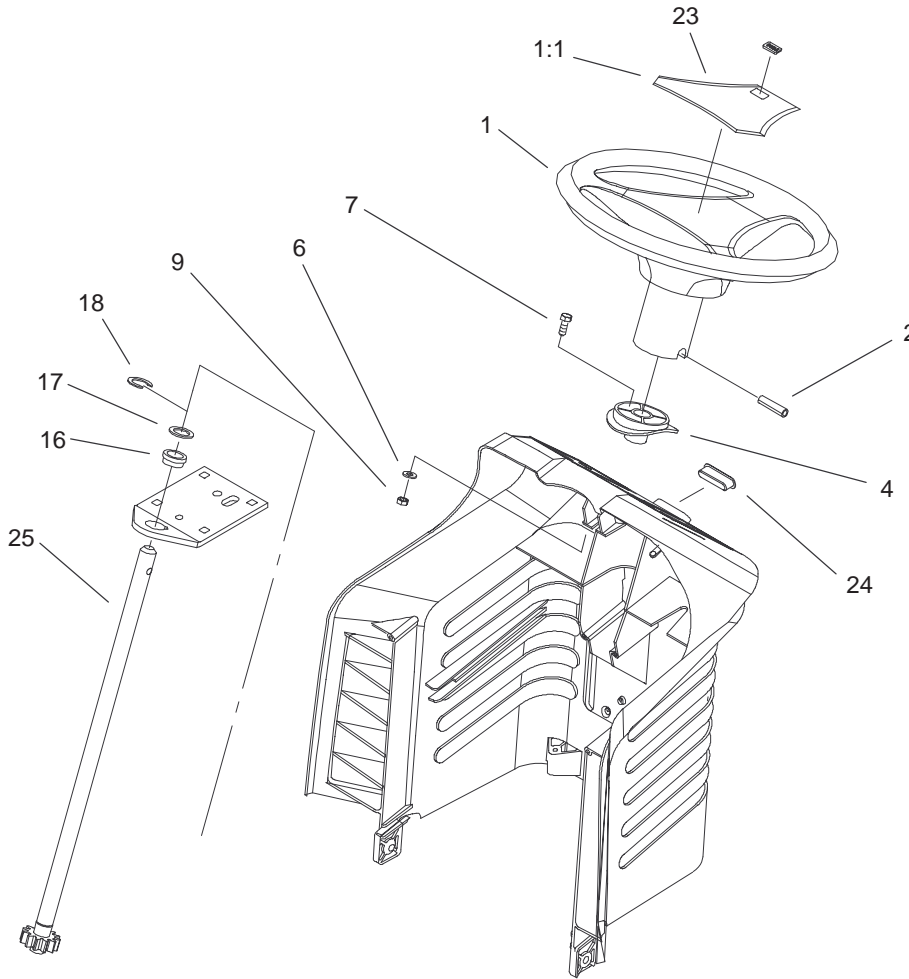

Sheet No.:7

Fixed Steering Assembly

Ref. No.	Part No.	Qty.	Description
1	98-1467	1	Wheel-Steering
1:1	98-1468	1	Cover-Wheel, Steering
2	32121-111	1	Pin-Roll
4	88-4190	1	Bushing-Sliding
6	3256-22	2	Washer-Flat
7	321-4	2	Screw-HH
9	3296-42	2	Nut-Lock, NI
16	88-5150	1	Bearing-Flange
17	3-6498	1	Washer-Thrust
18	32151-48	1	E-Ring
23	98-1459	1	Decal-Toro
24	88-4150	1	Plug
25	88-6380	1	Shaft-Long, Steering

Ref. No.	Part No.	Qty.	Description

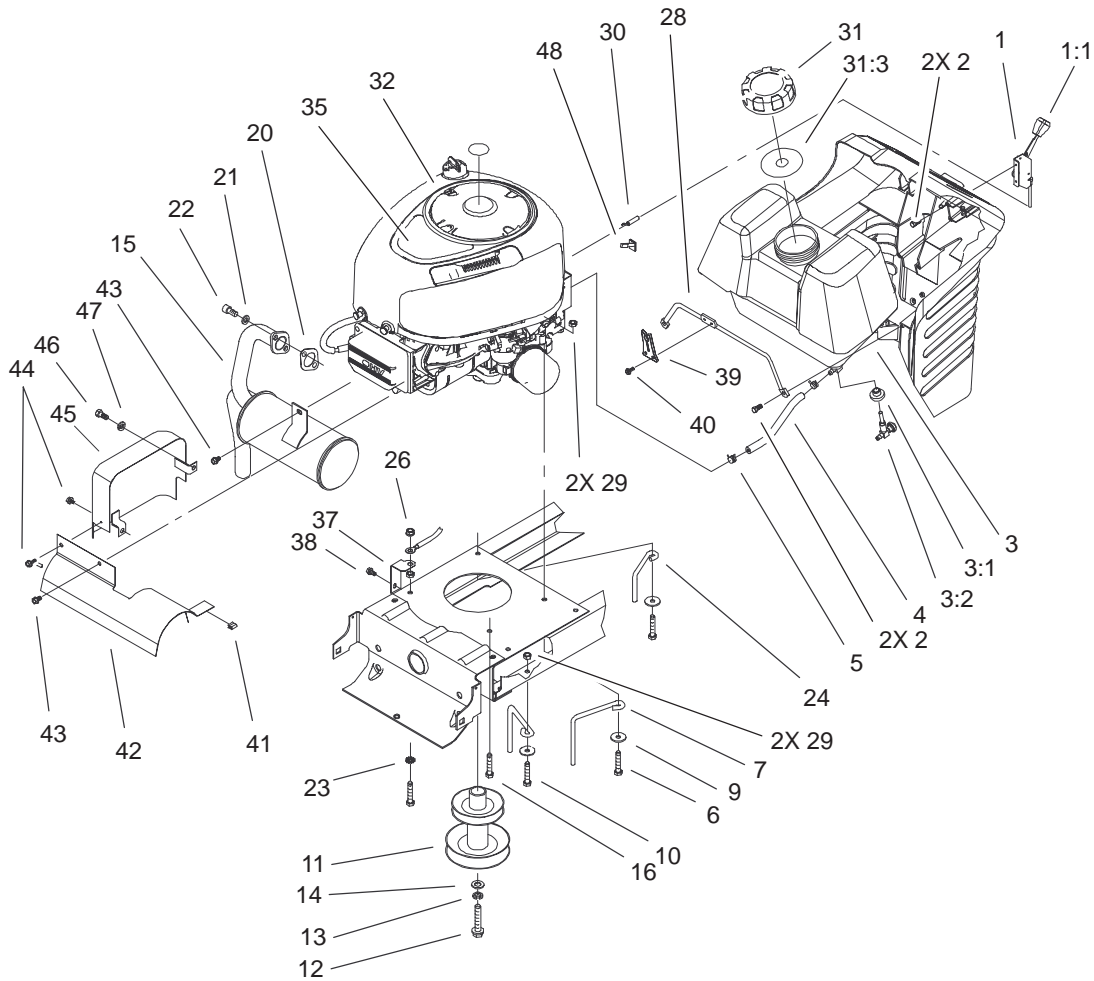

Sheet No.:8

Engine Assembly

Ref. No.	Part No.	Qty.	Description
1	88-4340	1	Control-Throttle
1:1	66-0120	1	Knob
2	27-0220	4	Screw-Special
3	88-3880	1	Gas Tank ASM
3:1	104047	1	Bushing
3:2	104048	1	Valve-Fuel
4	47-2963	1	Hose-Fuel
5	2412-98	2	Clamp
6	322-9	3	Screw-HH
7	93-3854	3	Guide-Belt, Engine
9	5-4460	4	Washer-Pivot
10	322-5	2	Screw-HH
11	94-1963	1	Pulley-Engine ASM
12	62-3760	1	Screw-HH
13	3253-22	1	Washer-Lock
14	3256-25	1	Washer-Flat
15	94-1953	1	Muffler-Exhaust
16	9267154	1	Screw
20	88-4410	1	Gasket-Muffler
21	3253-4	2	Washer-Lock
22	3274-10	2	Screw-HSH
23	3255-8	1	Washer-Lock
24	93-3855	1	Guide-Belt, RH
26	32149-1	2	Nut
28	94-1952	1	Rod-Gas, Tank
29	3296-29	4	Nut-Lock, NI

Ref. No.	Part No.	Qty.	Description
30	88-4350	1	Cable-Throttle
31	88-3980	1	Gas Cap ASM
31:3	88-4010	1	Gasket-Cap, Gas
☆32		1	Engine-14.5 Ohv Briggs And Stratton Model No. 280ho7-0160-E1
35	106-2184	1	Decal - Engine 14.5
37	93-3809	1	Bracket-Ground
38	9266714	1	Screw-HWH
39	94-1951	1	Latch-Hood
40	32144-112	2	Screw-HWHTF
41	93-3882	1	Clip-Tinnerman
42	93-3880-03	1	Shield-Muffler
43	9266714	2	Screw-HWH
44	32104-76	2	Screw
45	93-8450-03	1	Exhaust Shield ASM
46	322-3	1	Screw-HH
47	3253-4	1	Washer-Lock
48	88-4490	1	Reducer-Throttle, Rpm

☆ Not serviced separately

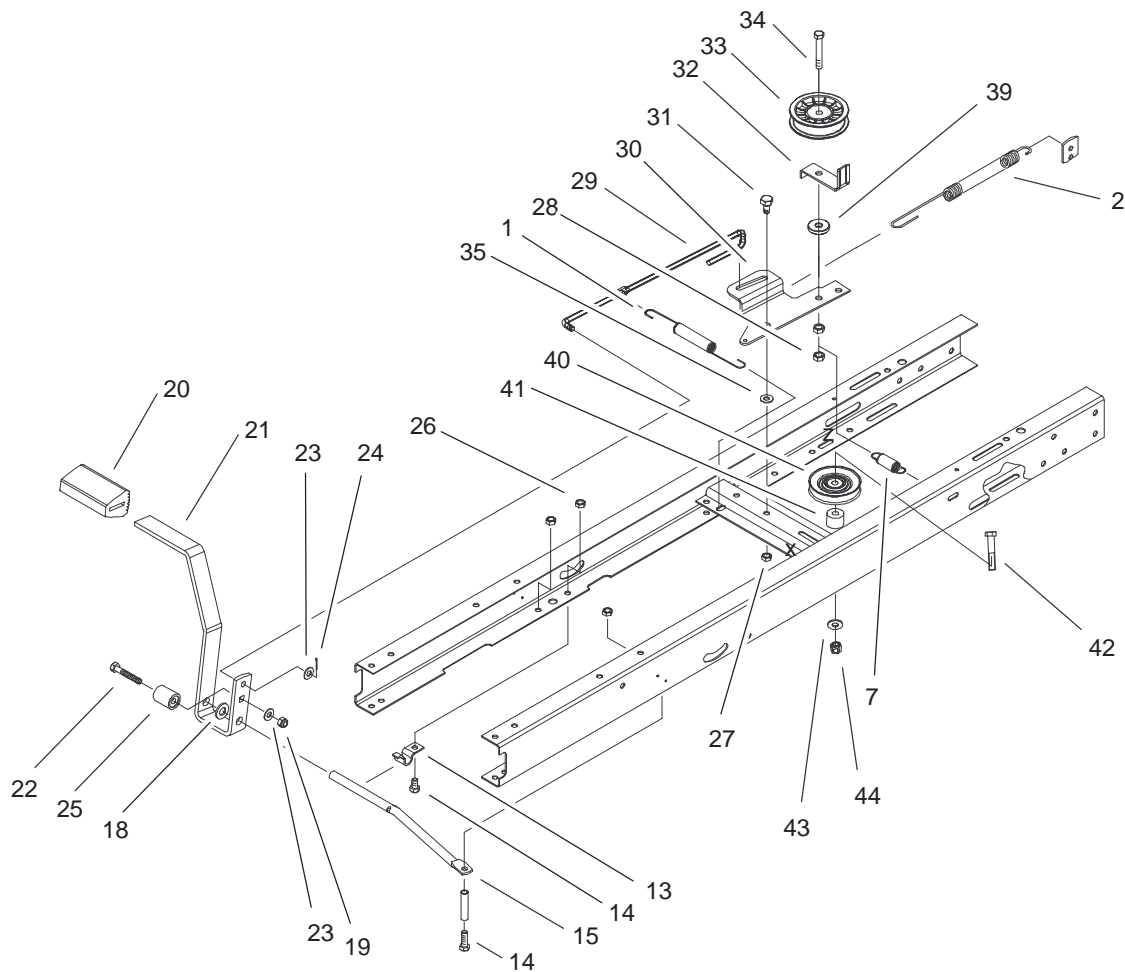

Sheet No.:9

Traction Clutching Assembly

Ref. No.	Part No.	Qty.	Description
1	27-8890	1	Spring-Return
2	100-7422	1	Spring-Brake
7	88-6330	1	Spring-Extension
13	88-4810	1	Clamp-Shift, Pivot
14	322-3	2	Screw-HH
15	88-5500	1	Rod-Pedal, Pivot
18	3256-26	1	Washer-Flat
19	3296-47	1	Nut-Lock, NI
20	65-2920	1	Pad-Pedal
21	88-5000-03	1	Pedal-Clutch/Brake
22	322-9	1	Screw-HH
23	3256-23	2	Washer-Flat
24	3272-10	1	Pin-Cotter
25	99-6836	1	Spacer-Switch
26	3296-29	2	Nut-Lock, NI
27	3296-29	1	Nut-Lock, NI
28	3296-59	2	Nut-Lock, NI
29	88-5270	1	Rod-Clutch/Brake
30	88-6070	1	Arm-Idler
31	37-8770	1	Bolt-Shoulder
32	88-5560	1	Guide-Idler, Belt
33	104-4160	1	Pulley-Idler
34	323-11	1	Screw-HH
35	5-4460	1	Washer-Pivot
39	92-4890	1	Washer-Wheel
40	92-7102	1	Pulley-Idler

Ref. No.	Part No.	Qty.	Description
41	92-5791	1	Spacer
42	323-10	1	Screw-HH
43	3256-3	1	Washer-Flat
44	3296-39	1	Nut-Lock, NI

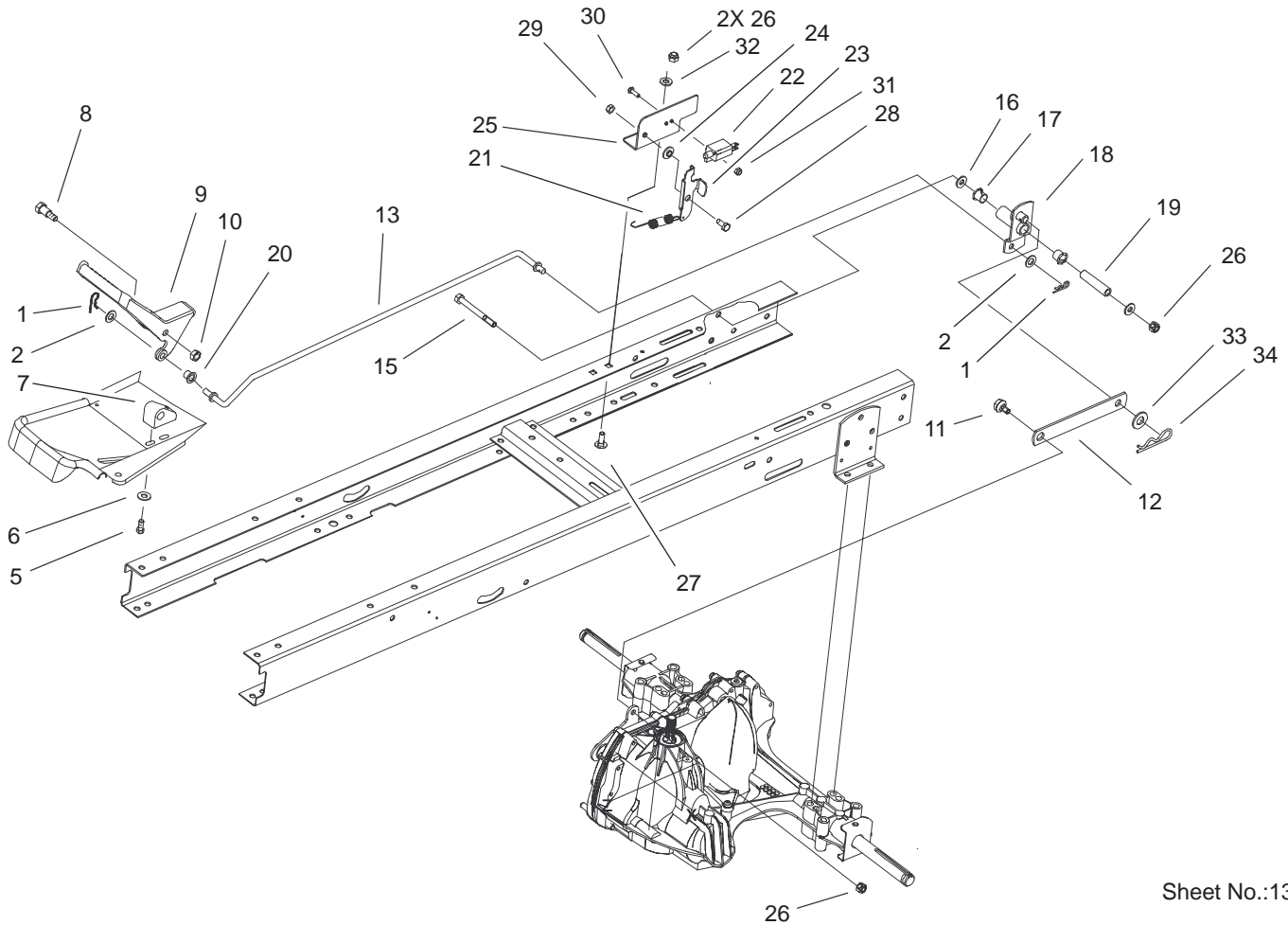

Sheet No.:13

Hydro Transaxle Control Assembly

Ref. No.	Part No.	Qty.	Description
1	3290-307	2	Pin-Hair
2	3256-38	2	Washer-Flat
5	46-8090	2	Screw-Plastite
6	3256-22	2	Washer-Flat
7	88-4690	1	Block-Pivot
8	23-0310	1	Bolt-Shoulder
9	99-6120-05	1	Pedal-Control, Speed
10	3296-59	1	Nut-Lock, NI
11	37-8770	1	Bolt-Shoulder
12	99-6833	1	Link-Control, Speed
13	99-6839	1	Rod-Control, Speed
15	322-14	1	Screw-HH
16	3256-2	2	Washer-Flat
17	256-257	2	Flange-Nyliner
18	99-6835-03	1	Pivot ASM
19	99-6832	1	Spacer-Pivot
20	99-6121	1	Bushing
21	99-6805	1	Spring-Extension
22	95-1653	1	Switch-Pole, Single
23	99-6807	1	Bracket-Pivot
24	99-6808	1	Washer-Stepped
25	99-6806	1	Bracket-Adjustment
26	3296-29	4	Nut-Lock, NI
27	3230-18	2	Screw-CARR
28	99-6810	1	Screw-HH
29	3296-42	1	Nut-Lock, NI

Ref. No.	Part No.	Qty.	Description
30	3290-392	2	Screw-HHF
31	3296-1	2	Nut-Lock NI
32	3256-23	2	Washer-Flat
33	3256-26	1	Washer-Flat
34	9335054	1	Pin-Hair

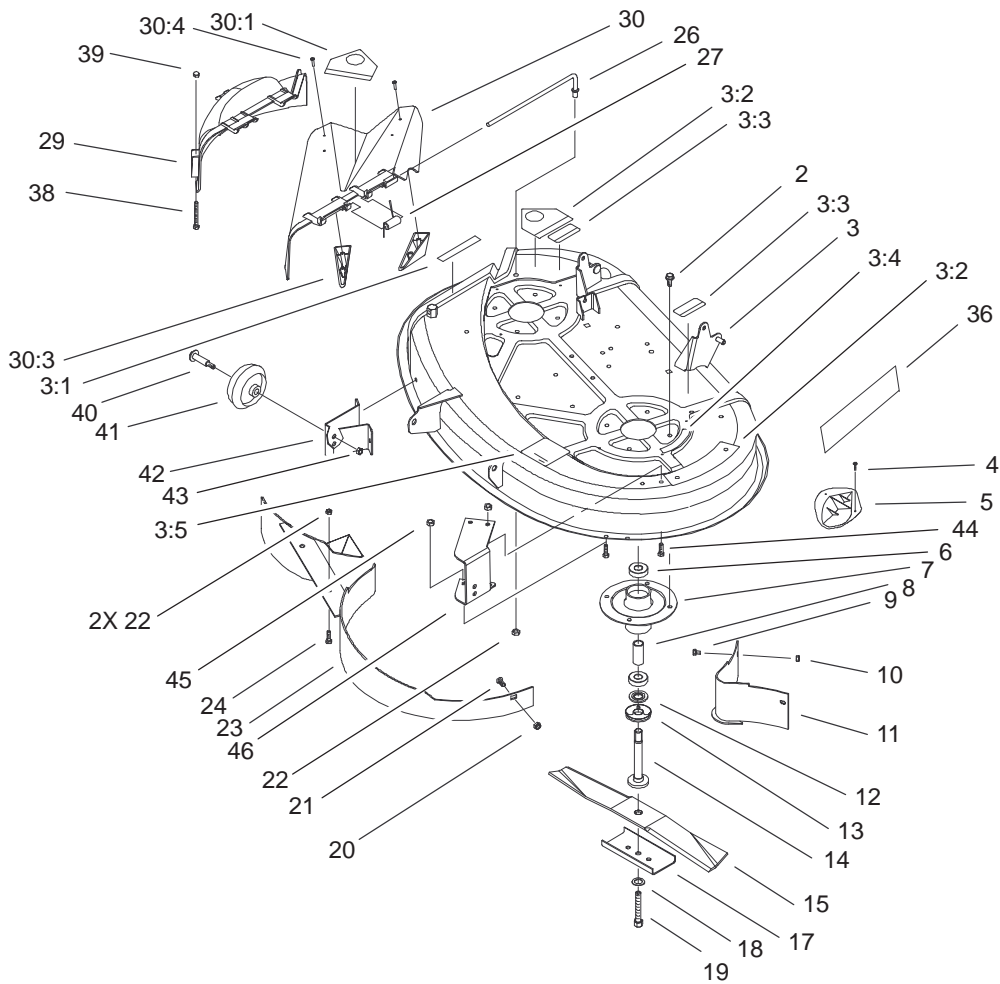

Sheet No.:16

38in Deck Assembly

Ref. No.	Part No.	Qty.	Description
2	32144-41	8	Screw-Taptite
3	99-5847	1	Deck ASM
3:1	93-7009	1	Decal-Danger
3:2	93-7010	2	Decal-Danger
3:3	93-6674	2	Decal-Warning
3:4	93-6677	1	Decal-Shield, Danger
3:5	93-6679	1	Decal-Routing, Belt
4	32144-111	8	Screw-PPH
5	76-2160	4	Plate-Kicker
6	100-1048	4	Bearing-Ball
7	88-4510	2	Spindle
8	62-3661	2	Spacer-Bearing
9	321-4	2	Screw-HH
10	3296-42	2	Nut-Lock, NI
11	79-1640-03	1	Baffle
12	80-4380	2	Spacer
13	80-4360	2	Shield-Bearing
14	80-4341	2	Spindle-Shaft
15	79-3061	2	Blade
17	80-0510-03	2	Stiffener-Blade
18	3290-465	2	Washer-Belleville
19	26-0671	2	Screw-Blade
20	3296-29	1	Nut-Lock, NI
21	3230-1	1	Bolt-CARR
22	3296-39	3	Nut-Lock, NI
23	79-1600-03	1	Baffle

Ref. No.	Part No.	Qty.	Description
24	323-5	2	Screw-HH
26	95-1661	1	Rod-Pivot
27	57-6950	1	Spring
29	88-4430	1	Recycler Cover
30	93-7695	1	Deflector ASM
30:1	93-7010	1	Decal-Danger
30:3	93-7696	2	Kicker
30:4	93-0231	4	Screw-PPH
36	106-6407	1	Decal-Recycler,38"
38	321-14	2	Screw-HH
39	32111-7	2	Nut-Cap
40	56-6591	2	Bolt-Wheel
41	701756	2	Wheel-Gage
42	88-5740-03	1	Bracket-Wheel, RH
43	3296-39	2	Nut-Lock, NI
44	322-3	6	Screw-HH
45	3296-29	6	Nut-Lock, NI
46	93-3896-03	1	Bracket-Wheel, LH

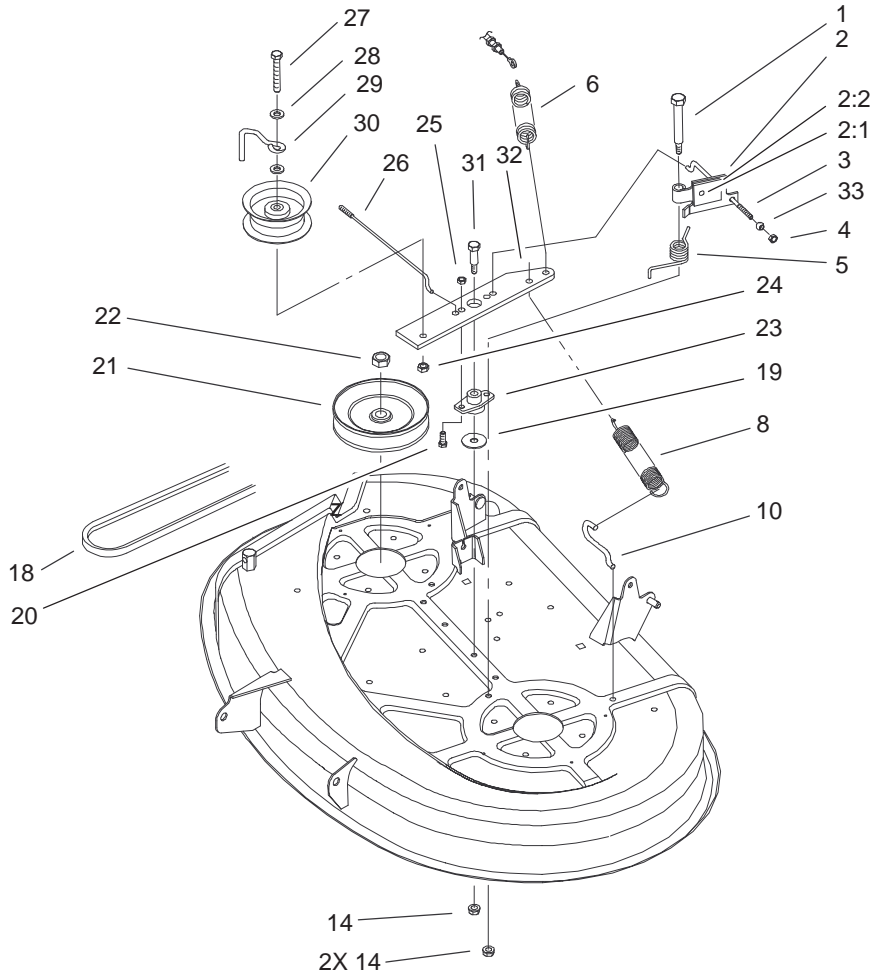

Sheet No.:17

38in Deck Blade Drive and Braking Assembly

Ref. No.	Part No.	Qty.	Description
1	88-4590	2	Bolt-Shoulder
2	88-6100	2	Brake ASM
2:1	3290-282	2	Rivet-Pop, Steel
2:2	56-9830	1	Pad-Brake
3	88-5550	1	Rod-Brake, Deck LH
4	3296-42	2	Nut-Lock, NI
5	88-5910	2	Spring-Torsion
6	88-6130	1	Spring-Deck, Engagement
8	92-8934	1	Spring-Extension
10	88-5970	1	Hook-Return, Spring
14	3296-58	3	Nut-Lock NI
18	88-6250	1	V-Belt
19	3256-68	1	Washer-Flat
20	322-5	2	Screw-HH
21	88-5330	2	Pully-Deck
22	3219-6	2	Nut-Hex
23	88-4980	1	Bushing-Idler, Arm
24	3296-39	1	Nut-Lock, NI
25	3296-29	2	Nut-Lock, NI
26	88-5540	1	Rod-Brake, Deck RH
27	323-12	1	Screw-HH
28	3256-24	2	Washer-Flat
29	88-5070	1	Guide-Idler, Belt
30	88-5630	1	Pulley-Idler Flat
31	7-0030	1	Bolt-Shoulder

Ref. No.	Part No.	Qty.	Description
32	88-4870-03	1	Arm-Idler, Deck
33	67-0710	2	Ball-Swivel, Stop

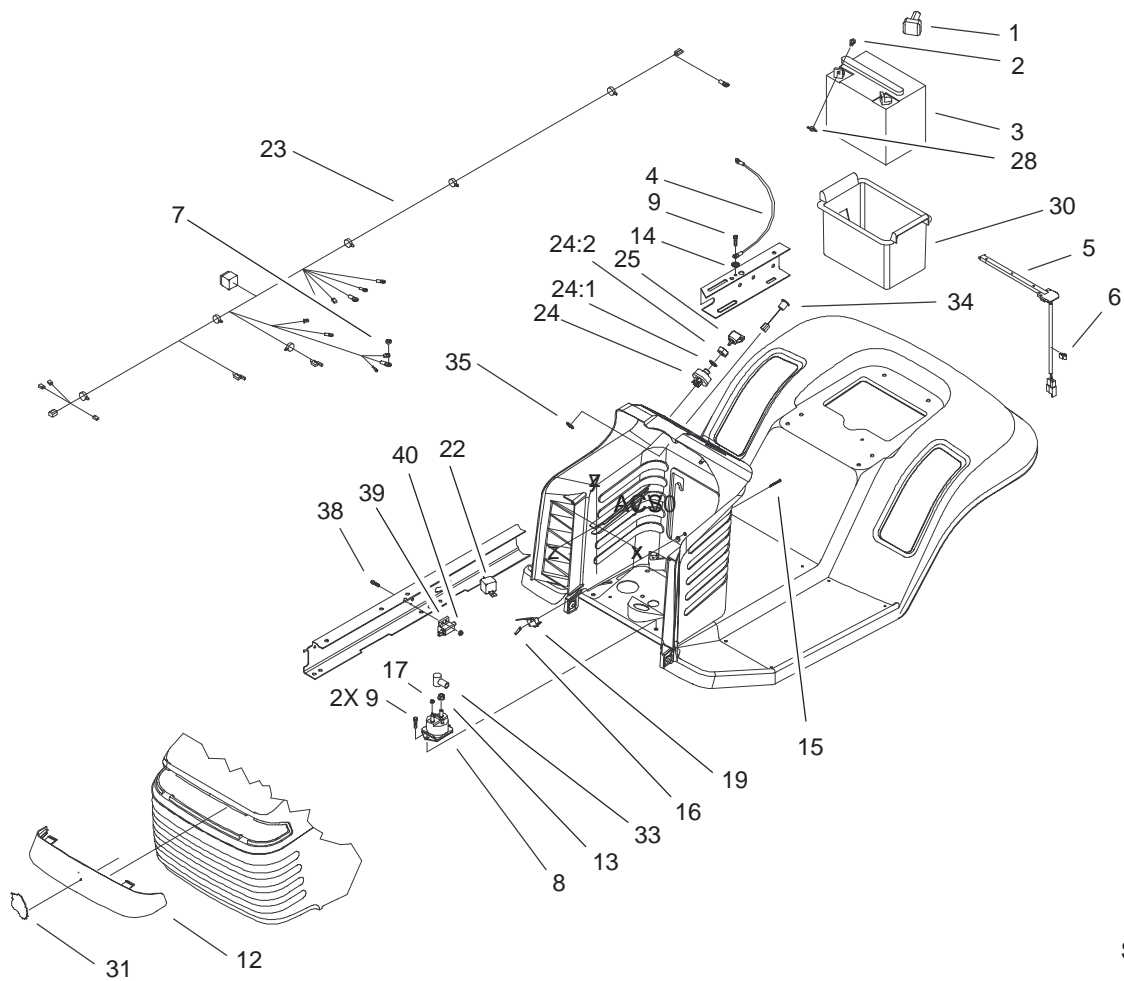

Sheet No.:20

Electrical Assembly

Ref. No.	Part No.	Qty.	Description
1	28-8080	1	Boot-Terminal
2	321-4	2	Screw-HH
3	104-1755	1	Battery
4	44-8110	1	Wire ASM
5	38-1420	1	Switch-Seat
6	702366	1	Clip-Wire Retainer
7	32149-2	1	Nut
8	28-4210	1	Solenoid
9	9266714	3	Screw-HWH
12	88-3960	1	Lens-Headlight
13	32149-1	2	Nut
14	3255-7	2	Washer-Lock/Ext
15	93-0539	2	Screw-HH
16	3290-354	1	Nut-Speed
17	32149-8	2	Nut-Keps
19	88-9932	1	Switch-Micro
22	98-7249	1	Relay
23	99-6840	1	Harness-Wire, Hydro
24	88-9830	1	Key Switch ASM
24:1	3254-5	1	Washer-Tooth
24:2	218-461	1	Nut-HH
25	63-8360	1	Key-Ignition
28	32103-22	2	Nut-Wing
30	88-4040	1	Box-Battery
31	95-4248	1	Logo-Horsehead

Ref. No.	Part No.	Qty.	Description
33	93-3190	1	Boot-Insulator, Terminal
34	95-7652	1	Light-Indicator
35	99-6059	1	Clip-Retainer
38	3274-14	2	Screw-HSH
39	65-7410	1	Switch-Pole, Single
40	3296-2	2	Nut-Lock

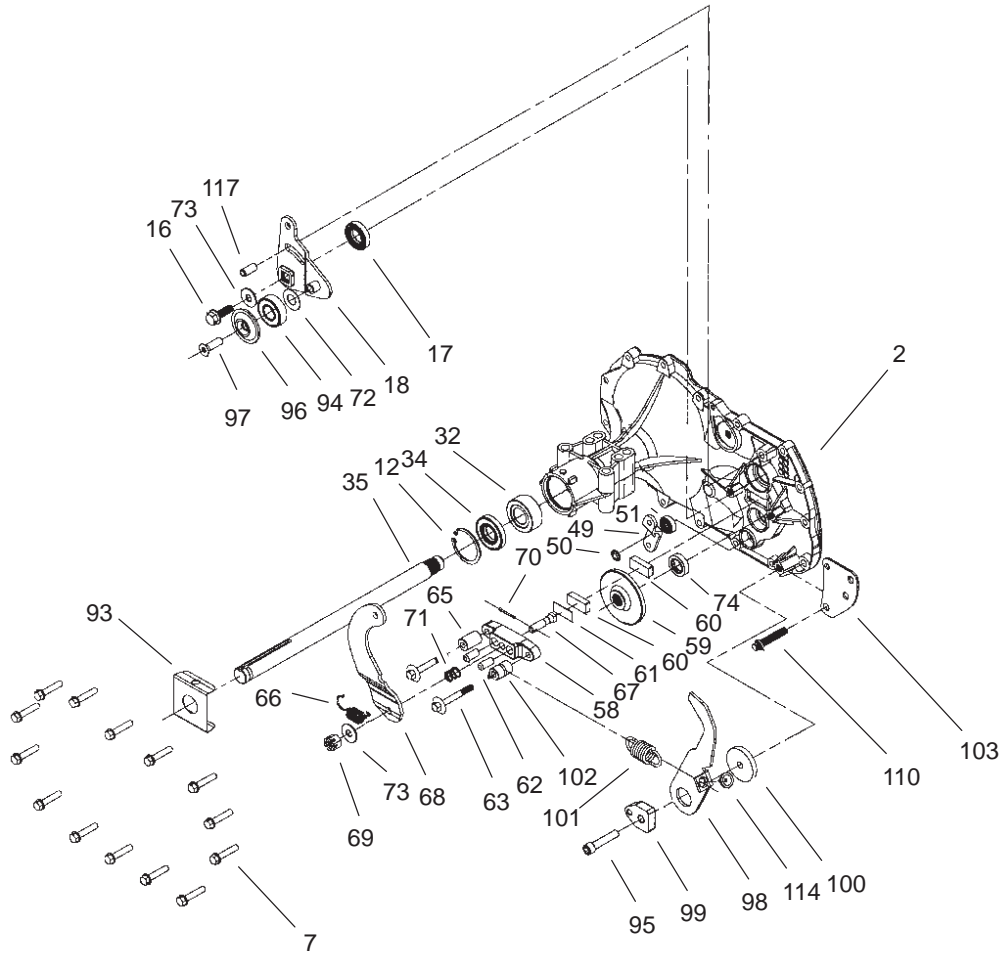

Sheet No.:3

Housing and Bearing Assembly

Ref. No.	Part No.	Qty.	Description
2	104-5302	1	Side Housing ASM
7	104-5305	14	Screw-Hex Flange
12	104-5309	1	Ring-Retaining
16	104-5312	1	Screw-Hex Flange
17	104-5313	1	Seal-Lip
18	104-5314	1	Arm-Control
32	104-5321	1	Bearing-Sleeve, Outboard
34	104-5322	1	Seal-Lip
35	104-5323	1	Shaft-Axle RH
49	104-5336	1	Arm-Bypass
50	104-5337	1	Ring-Retaining
51	104-5338	1	Seal-Lip
58	104-5343	1	Yoke-Brake
59	104-5344	1	Rotor-Brake
60	104-2171	2	Puck-Brake
61	104-2181	1	Puck-Plate
62	104-2176	2	Pin-Brake
63	104-5345	2	Screw-Hex Flange
65	104-2180	1	Spacer
66	104-2184	1	Spring-Brake Arm
67	104-2174	1	Bolt-SQH
68	104-5346	1	Arm-Brake
69	93-3807	1	Nut - Castle
70	104-2179	1	Pin-Cotter

Ref. No.	Part No.	Qty.	Description
71	104-2188	1	Spring-Brake, Anti Drag
72	94-1933	1	Washer
73	104-2146	2	Washer
74	104-5347	1	Seal-Oil
93	104-5353	1	Clip-Spring
94	104-2156	1	Bearing
95	104-2155	1	Screw
96	104-2157	1	Spacer-Locating
97	104-2158	1	Screw-Countersunk
98	104-5354	1	Arm-Return
99	104-2119	1	Puck-Adjusting
100	104-5355	1	Washer
101	104-5356	1	Spring-Extension
102	104-5357	1	Spacer
103	104-5358	1	Bracket-Torque
110	104-2148	1	Screw-TTH
114	104-5363	1	Guide-Spring
117	104-5365	1	Pin-Spring

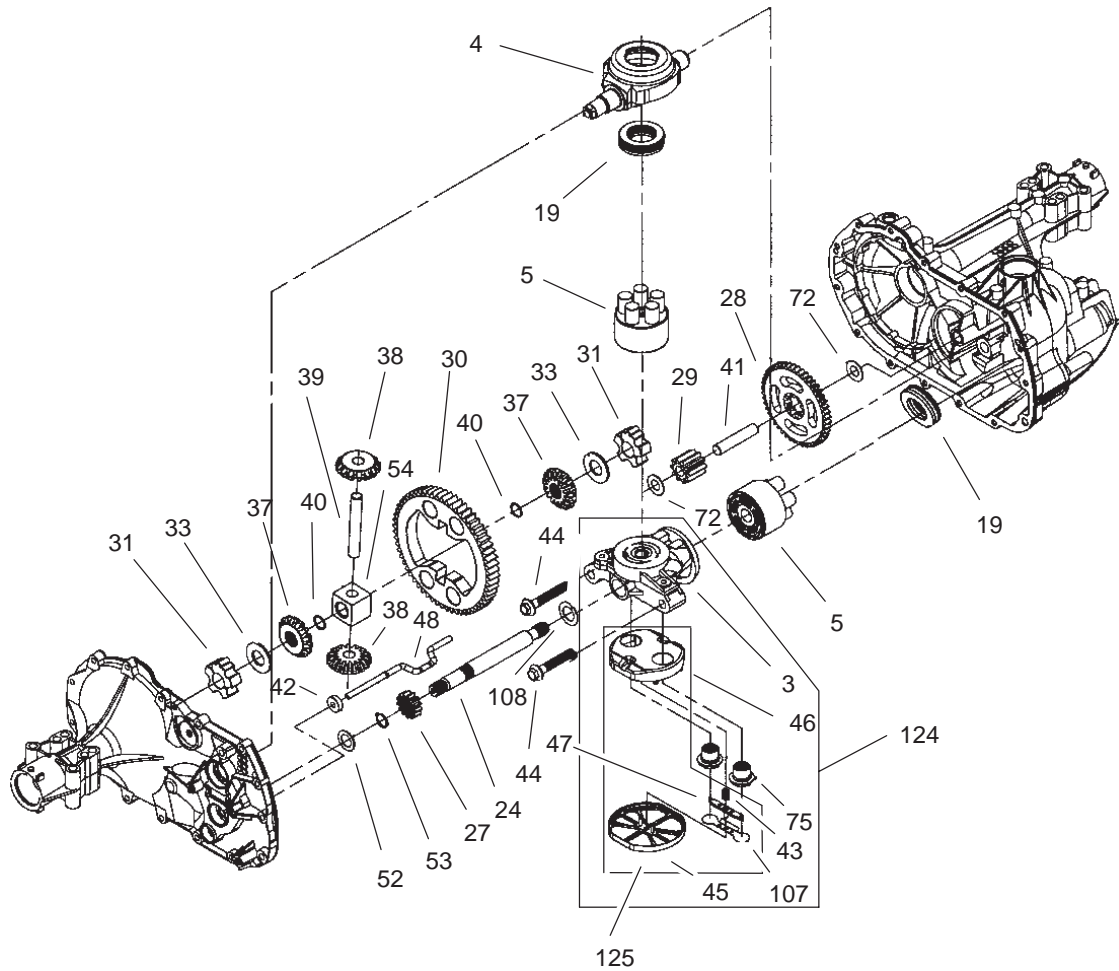

Sheet No.:4

Gear Assembly

Ref. No.	Part No.	Qty.	Description
3	104-5303	1	Center Section ASM
4	104-5304	1	Swashplate-Trunnion Machined
5	104-2106	2	Cylinder Block ASM
19	94-6922	2	Bearing-Thrust
24	104-5315	1	Shaft-Motor
27	104-5316	1	Gear-Pinion, 13t
28	104-5317	1	Gear- 10t/48t
29	104-5318	1	Gear-Jackshaft 10t
30	104-5319	1	Gear-Bull 60t
31	104-5320	2	Bearing-Sleeve
33	94-1943	2	Washer
37	104-5325	2	Gear-Miter
38	104-5326	2	Gear-Miter 15t
39	104-5327	1	Shaft
40	104-5328	2	Ring-Spiral Retaining
41	104-5329	1	Pin-Jackshaft
42	104-5330	1	Magnet-Ring
43	104-5331	1	Spring-Bypass
44	94-6926	2	Bolt
47	104-5334	1	Actuator-Bypass
48	104-5335	1	Rod-Bypass Actuator
52	104-5339	1	Washer-Flat
53	104-5340	1	Ring-Retaining
54	104-5341	1	Bearing-Center Block
72	94-1933	2	Washer

Ref. No.	Part No.	Qty.	Description
75	104-5348	2	Check Plug ASM
107	104-5359	1	Deflector
108	104-5360	1	Washer-Motor Shaft
124	106-6522	1	Bypass ASM-Center Section-Filter
125	106-6523	1	Filter Assembly
*127	104-5368	1	Seal-O-Ring Kit

* Not illustrated

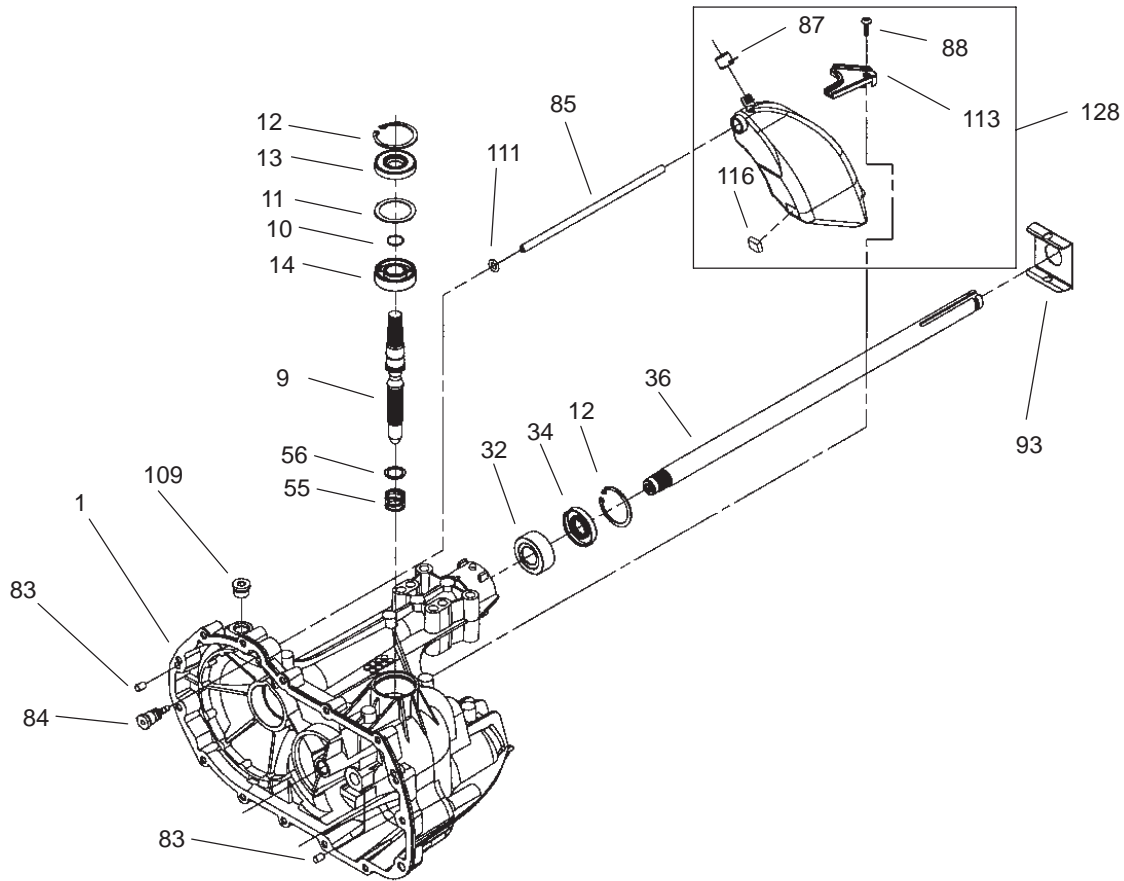

Sheet No.:5

Axle Assembly

Ref. No.	Part No.	Qty.	Description
1	104-5301	1	Main Housing ASM
9	104-5306	1	Shaft-Input
10	104-5307	1	Ring-Retaining
11	104-5308	1	Spacer
12	104-5309	2	Ring-Retaining
13	104-5310	1	Seal-Lip
14	104-5311	1	Bearing-Ball
32	104-5321	1	Bearing-Sleeve, Outboard
34	104-5322	1	Seal-Lip
36	104-5324	1	Shaft-Axle LH
55	94-1936	1	Spring-Block
56	94-1937	1	Washer-Block, Thrust
83	104-2170	2	Pin
84	104-5349	1	Fitting-Sae
85	104-5350	1	Hose-Expansion Tank
87	104-5351	1	Cap-Vent
88	104-5352	1	Bolt-Self Tapping
93	104-5353	1	Clip-Spring
109	104-2189	1	Plug-Straight Thread
111	104-5361	1	O-Ring
113	104-5362	1	Bracket-Support
116	104-5364	1	Sponge-Sillicone
128	104-5369	1	Expansion Tank Kit

Ref. No.	Part No.	Qty.	Description

Electric Schematic

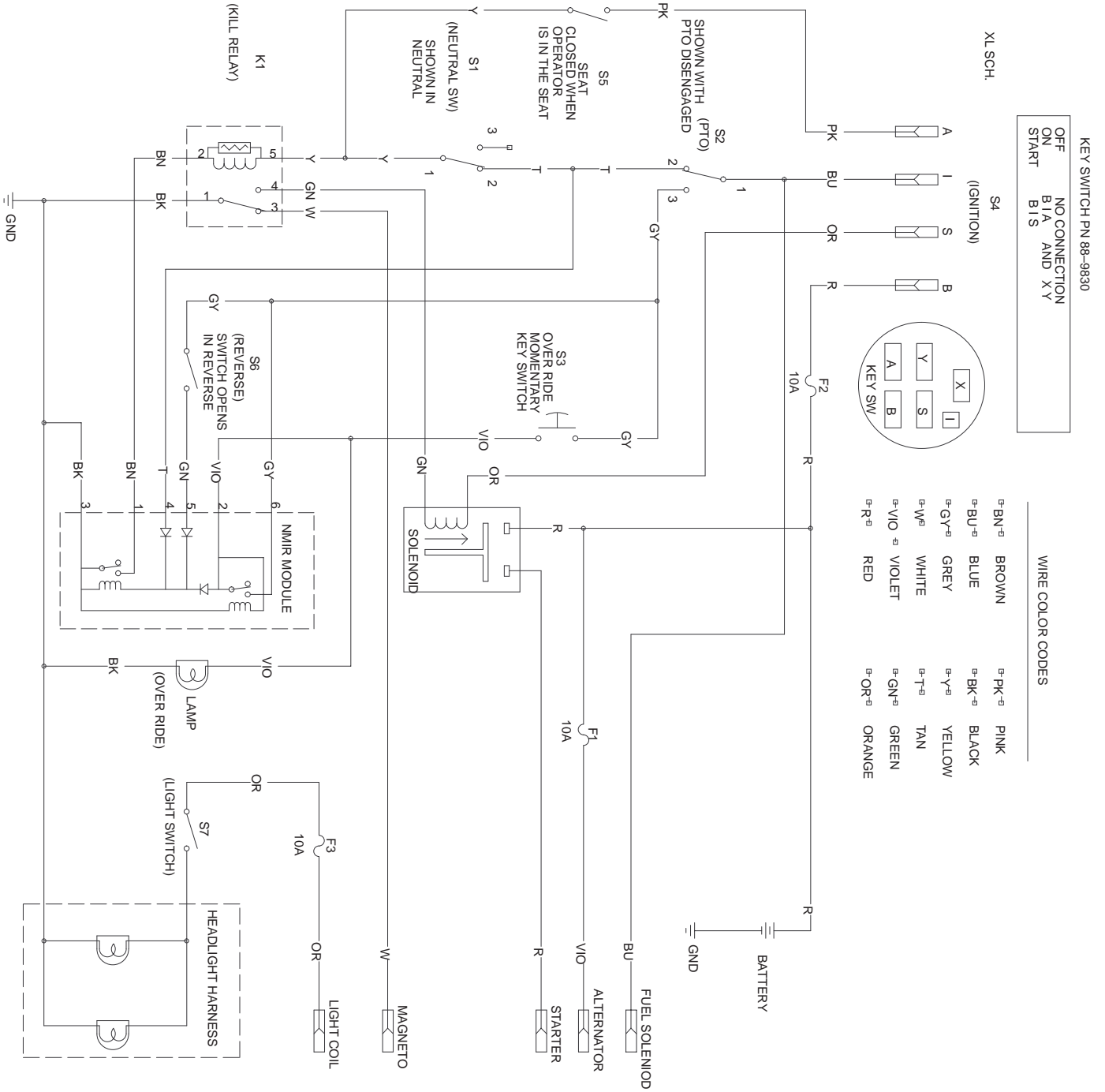

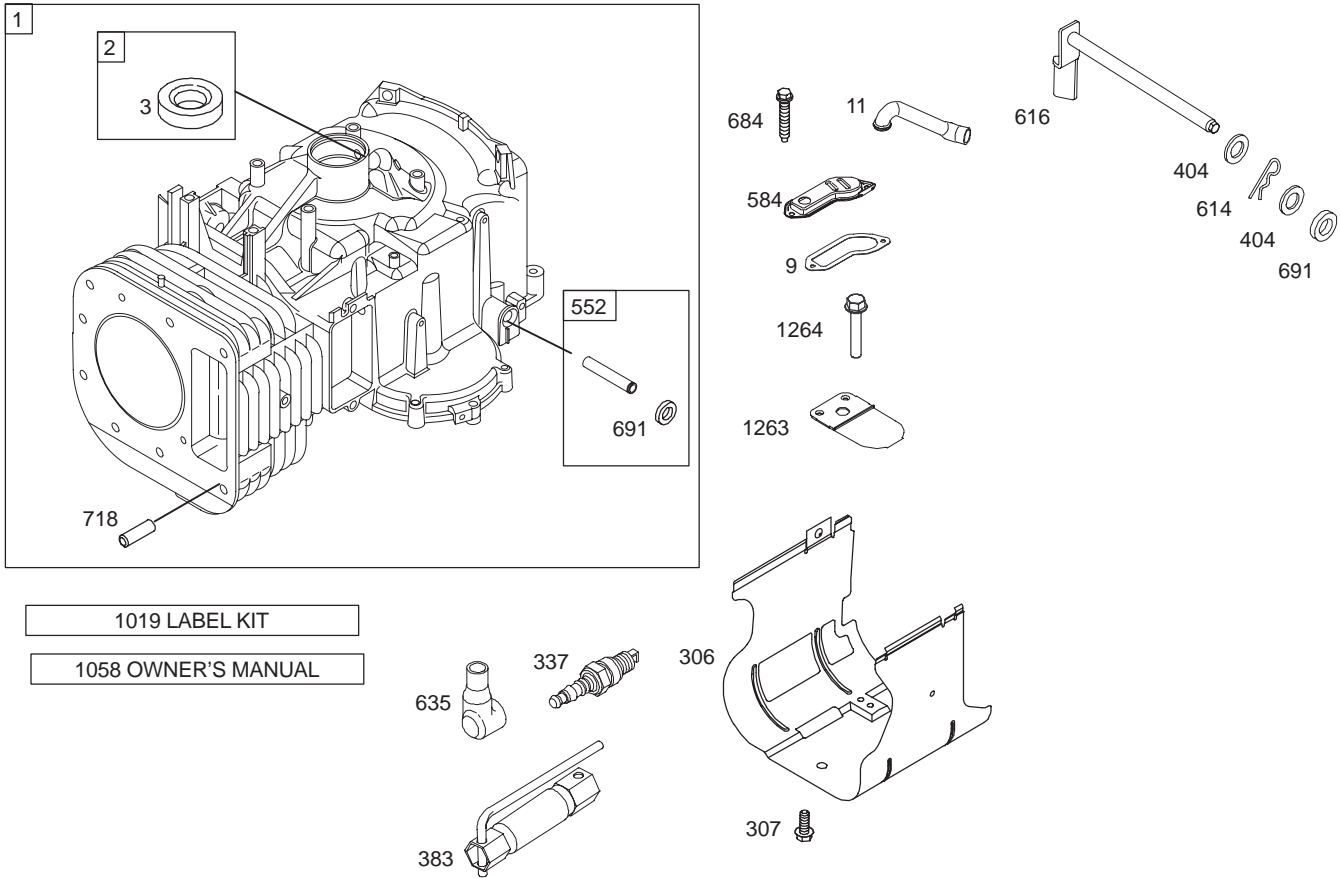

1019 LABEL KIT

1058 OWNER'S MANUAL

Assemblies include all parts shown in frames.

Cylinder Assembly Engine Briggs and Stratton Model 280H07-0160-E1

Ref. No.	Part No.	Qty.	Description
1	697132	1	Cylinder Assembly
2	399265	1	Kit-Bushing/Seal (Magneto Side)
★3	391086	1	Seal-Oil (Magneto Side)
★9	697109	1	Gasket-Breather
11	697113	1	Tube-Breather
306	697107	1	Shield-Cylinder
307	691003	1	Screw (Cylinder Shield)
337	691043	1	Plug-Spark
383	89838	1	Wrench-Spark Plug
404	691691	1	Washer (Governor Crank)
552	697144	1	Bushing-Governor Crank
584	697112	1	Cover-Breather Passage
614	691620	1	Pin-Cotter
616	692012	1	Crank-Governor
635	691909	1	Boot-Spark Plug
684	697157	1	Screw (Breather Passage Cover)

Ref. No.	Part No.	Qty.	Description
★691	692407	1	Seal-Governor Shaft
718	690959	1	Pin-Locating
1019	697143	1	Kit-Label
1058	275038	1	Owner's Manual
1263	697124	1	Reed-Breather
1264	697104	1	Screw (Breather Reed)
	691761	1	Short Block

★ Included in Engine Gasket Set-Ref. 358.

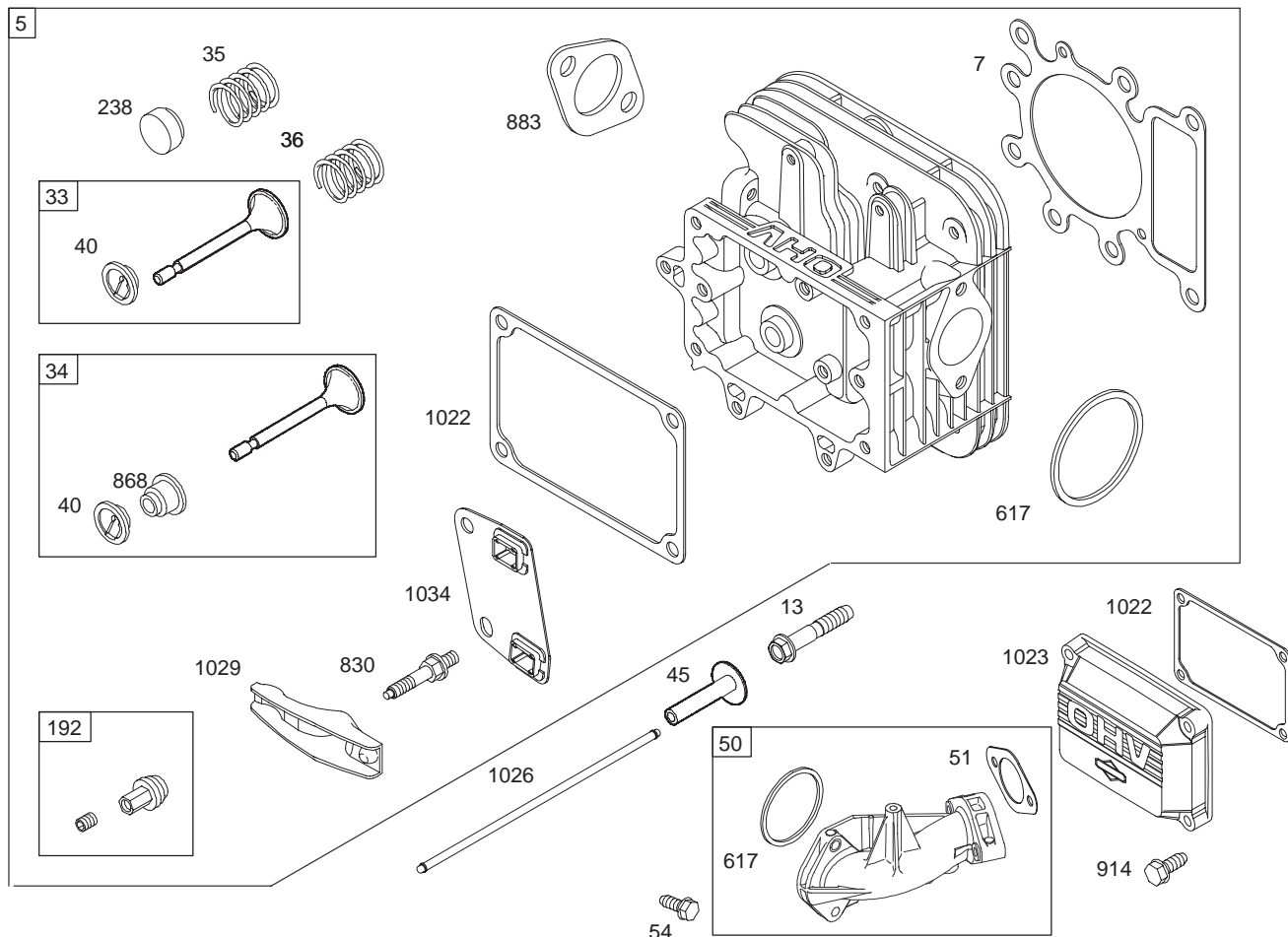

Cylinder Head Assembly Engine Briggs and Stratton Model 280H07-0160-E1

Ref. No.	Part No.	Qty.	Description
5	698148	1	Head-Cylinder
★7	273280	1	Gasket-Cylinder Head
13	690360	1	Screw (Cylinder Head Gasket)
33	695760	1	Valve-Exhaust
34	695761	1	Valve-Intake
35	691279	1	Spring-Valve (Intake)
36	691279	1	Spring-Valve (Exhaust)
40	690964	1	Retainer-Valve
45	690564	1	Tappet-Valve
50	690193	1	Manifold-Intake
★△◆51	692137	1	Gasket-Intake
54	691148	1	Screw (Intake Manifold)
192	691986	1	Adjustor-Rocker Arm
238	691843	1	Cap-Valve
★617	692138	1	Seal-O Ring (Intake Manifold)
830	691095	1	Stud-Rocker Arm
△★868	690968	1	Seal-Valve
883	692236	1	Gasket-Exhaust

Ref. No.	Part No.	Qty.	Description
914	690960	1	Screw (Rocker Cover)
★1022	272475	1	Gasket-Rocker Cover
1023	692492	1	Cover-Rocker
1026	692003	1	Rod-Push (Intake)
	692011	1	Rod-Push (Exhaust)
1029	691751	1	Arm-Rocker
1034	690822	1	Guide-Push Rod

△ Included in Valve Gasket Set-Ref. 1095.

● Included in Carburetor Overhaul Kit-Ref. 121.

★ Included in Engine Gasket Set-Ref. 358.

◆ Included in Carburetor Gasket Set-Ref. 977.

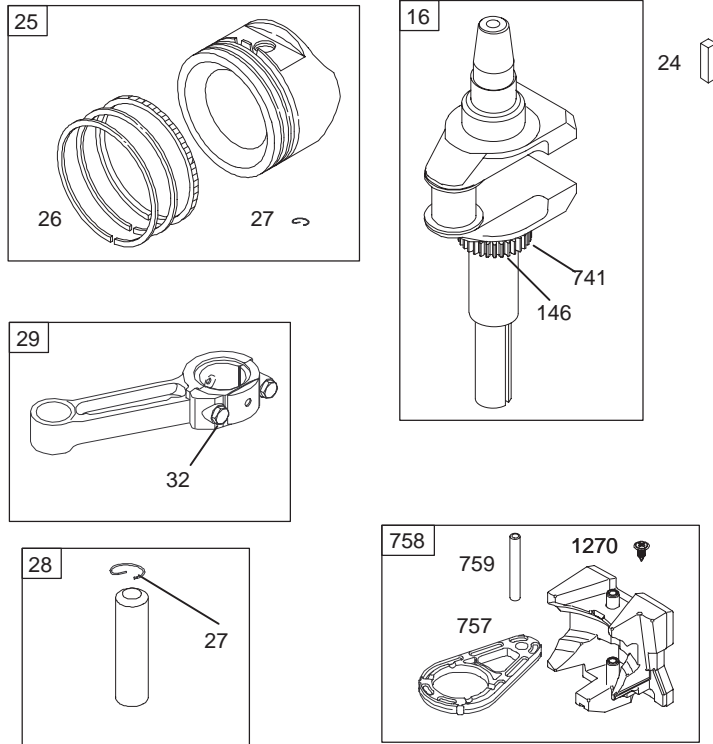

Assemblies include all parts shown in frames.

Crankshaft Assembly Engine Briggs and Stratton Model 280H07-0160-E1

Ref. No.	Part No.	Qty.	Description
16	697127	1	Crankshaft
24	222698	1	Key-Flywheel
25	698371	1	Piston Assembly (Standard)
	698372	1	Piston Assembly (.010" Oversize)
	698373	1	Piston Assembly (.020" Oversize)
	698374	1	Piston Assembly (.030" Oversize)
26	698375	1	Ring Set (Standard)
	698376	1	Ring Set (.010" Oversize)
	698377	1	Ring Set (.020" Oversize)
	698378	1	Ring Set (.030" Oversize)
27	698469	1	Lock-Piston Pin
28	697099	1	Pin-Piston (Standard)

Ref. No.	Part No.	Qty.	Description
29	697126	1	Rod-Connecting (Standard)
	697264	1	Rod-Connecting (.020" Undersize)
32	692852	1	Screw (Connecting Rod)
146	691639	1	Key-Timing
741	697128	1	Gear-Timing
757	697607	1	Link-Counterweight
758	697134	1	Counterweight
759	397392	1	Pin-Counterweight
1270	697156	1	Plug-AVS Counterweight

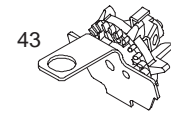
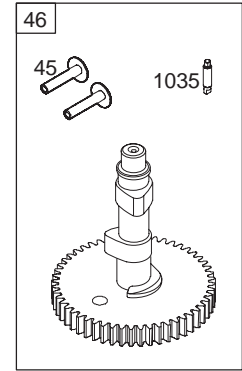
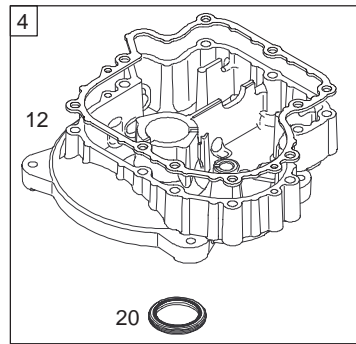

Assemblies include all parts shown in frames.

Crankcase Assembly Engine Briggs and Stratton Model 280H07-0160-E1

Ref. No.	Part No.	Qty.	Description
4	697106	1	Sump-Engine
★12	697110	1	Gasket-Crankcase
15	690946	1	Plug-Oil Drain
★20	690947	1	Oil Seal (PTO Side)
22	692125	1	Screw (Engine Sump)
43	691968	1	Governor/Oil Slinger
45	690564	1	Tappet-Valve
46	693450	1	Camshaft
1035	693784	1	Shaft-Pump

Ref. No.	Part No.	Qty.	Description

★ Included in Engine Gasket Set-Ref. 358.

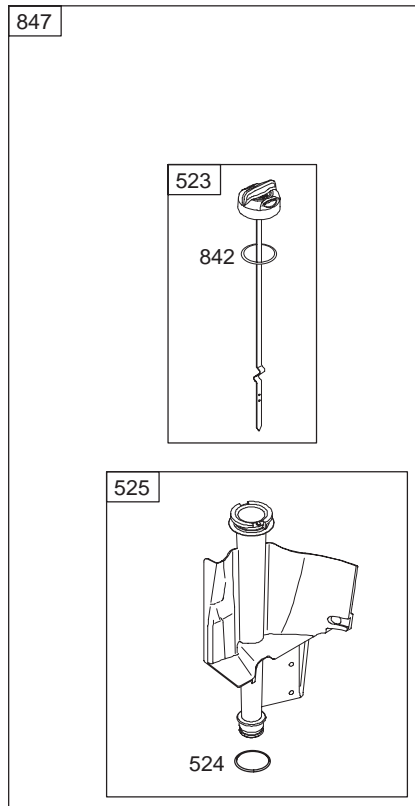

Assemblies include all parts shown in frames.

Oil Filter, Tube and Pump Assembly Engine Briggs and Stratton Model 280H07-0160-E1

Ref. No.	Part No.	Qty.	Description
523	697086	1	Dipstick
★524	691032	1	Seal-O Ring (Dipstick Tube)
525	697184	1	Tube-Dipstick
★842	691031	1	Seal-O Ring (Dipstick)
847	697611	1	Dipstick/Tube Assembly

Ref. No.	Part No.	Qty.	Description

★ Included in Engine Gasket Set-Ref. 358.

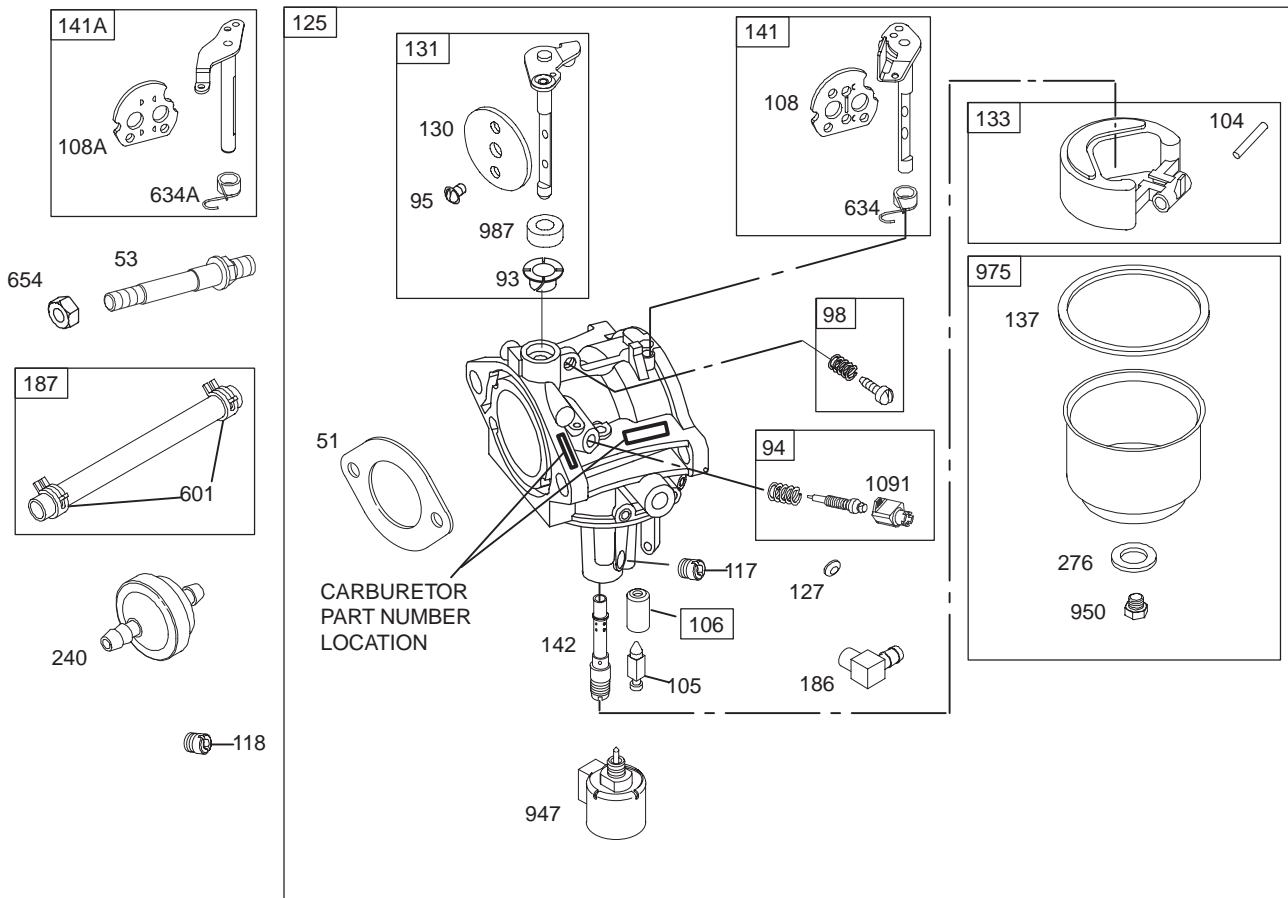

Assemblies include all parts shown in frames.

Carburetor Assembly Engine Briggs and Stratton Model 280H07-0160-E1

Ref. No.	Part No.	Qty.	Description
★▲◆51	692137	1	Gasket-Intake
53	690227	1	Stud (Carburetor)
●93	690602	1	Bushing-Throttle Shaft
94	498030	1	Kit-Idle Mixture
●95	691636	1	Screw (Throttle Valve)
98	495800	1	Kit-Idle Speed
●104	690525	1	Pin-Float Hinge
●105	231855	1	Valve-Float Needle
●106	690577	1	Seat-Inlet
108	690464	1	Valve-Choke (Manual Choke)
108A	692344	1	Valve-Choke (Choke A Matic)
●117	694352	1	Jet-Main (Standard)
118	697228	1	Jet-Main (High Altitude)
125	697190	1	Carburetor
127	695005	1	Plug-Welch
130	691750	1	Valve-Throttle
131	494379	1	Kit-Throttle Shaft
133	494381	1	Float-Carburetor

Ref. No.	Part No.	Qty.	Description
●◆137	281165	1	Gasket-Float Bowl
141	495097	1	Kit-Choke Shaft (Manual Choke)
141A	495931	1	Kit-Choke Shaft (Choke A Matic)
●142	697140	1	Nozzle-Carburetor
186	698174	1	Connector-Hose Line-Fuel (Cut to Required Length)
187	697098	1	Filter-Fuel
240	394358	1	Sealing Washer
●◆276	692255	1	Clamp-Hose
601	95162	1	Spring/Seal Assembly
●634	690801	1	Spring/Seal Assembly
●634A	690802	1	Nut (Carburetor)
654	690958	1	Solenoid-Fuel
947	694393	1	Screw (Float Bowl)
950	691657	1	Bowl-Float
975	495933	1	Seal-Throttle Shaft
●987	691326	1	Cap-Limiter
1091	691333	1	

▲ Included in Valve Gasket Set-Ref. 1095.
★ Included in Engine Gasket Set-Ref. 358.

● Included in Carburetor Overhaul Kit-Ref. 121.
◆ Included in Carburetor Gasket Set-Ref. 977.

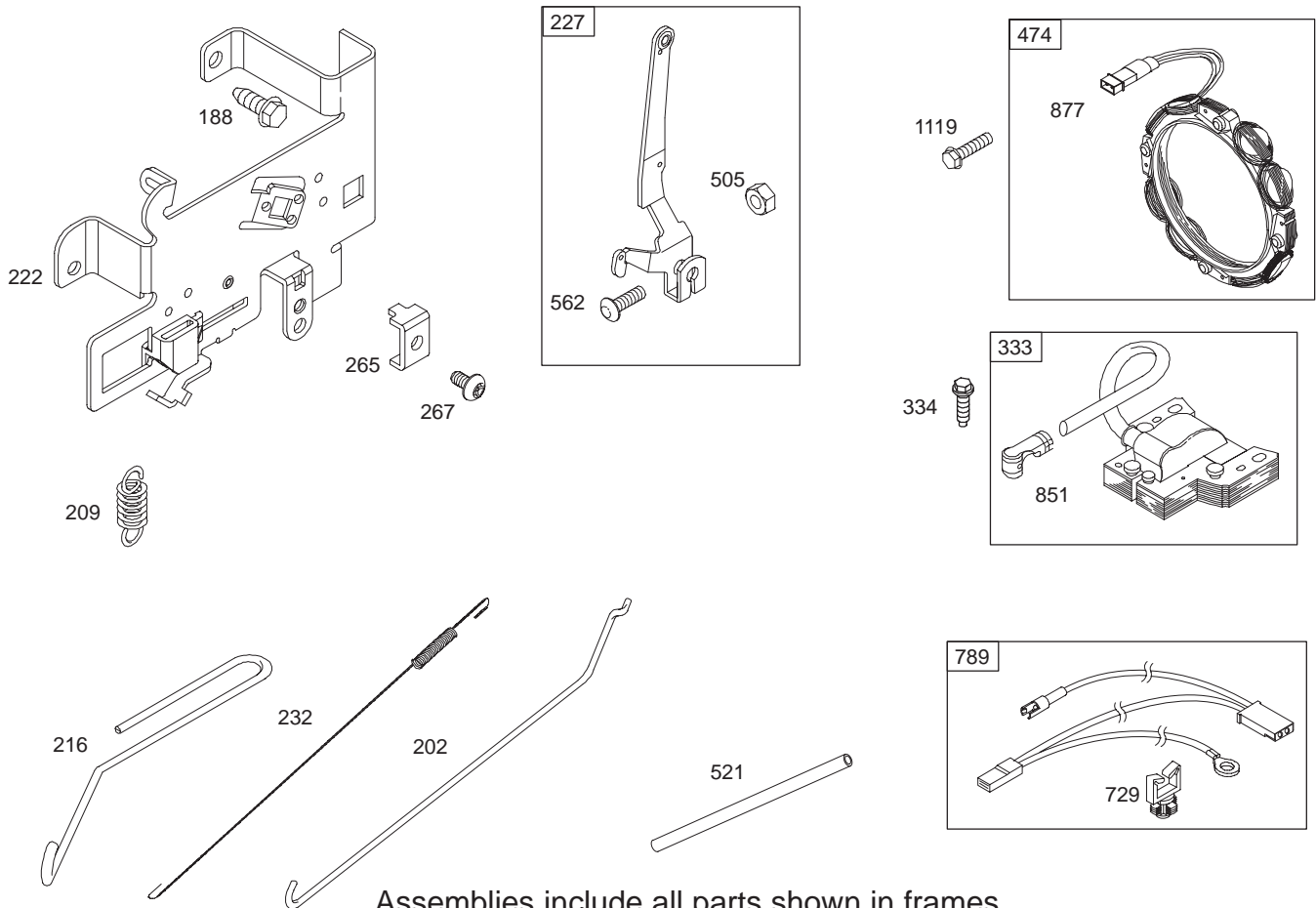

Assemblies include all parts shown in frames.

Governor Assembly Engine Briggs and Stratton Model 280H07-0160-E1

Ref. No.	Part No.	Qty.	Description
188	691693	1	Screw (Control Bracket)
202	691841	1	Link-Mechanical Governor
209	692208	1	Spring-Governor
216	691840	1	Link-Choke
222	694042	1	Bracket-Control
227	691374	1	Lever-Governor Control
232	691842	1	Spring-Governor Link
265	691024	1	Clamp-Casing
267	695134	1	Screw (Casing Clamp)
333	492341	1	Armature-Magneto
334	691061	1	Screw (Magneto Armature)
474	696459	1	Alternator
505	691251	1	Nut (Governor Control Lever)
521	690581	1	Shield-Cable
562	691119	1	Bolt (Governor Control Lever)

Ref. No.	Part No.	Qty.	Description
729	691335	1	Clip-Wire
789	692037	1	Wiring-Harness
851	493880	1	Terminal-Spark Plug
877	393456	1	Wire/Connector-Alternator
1119	691183	1	Screw (Alternator)

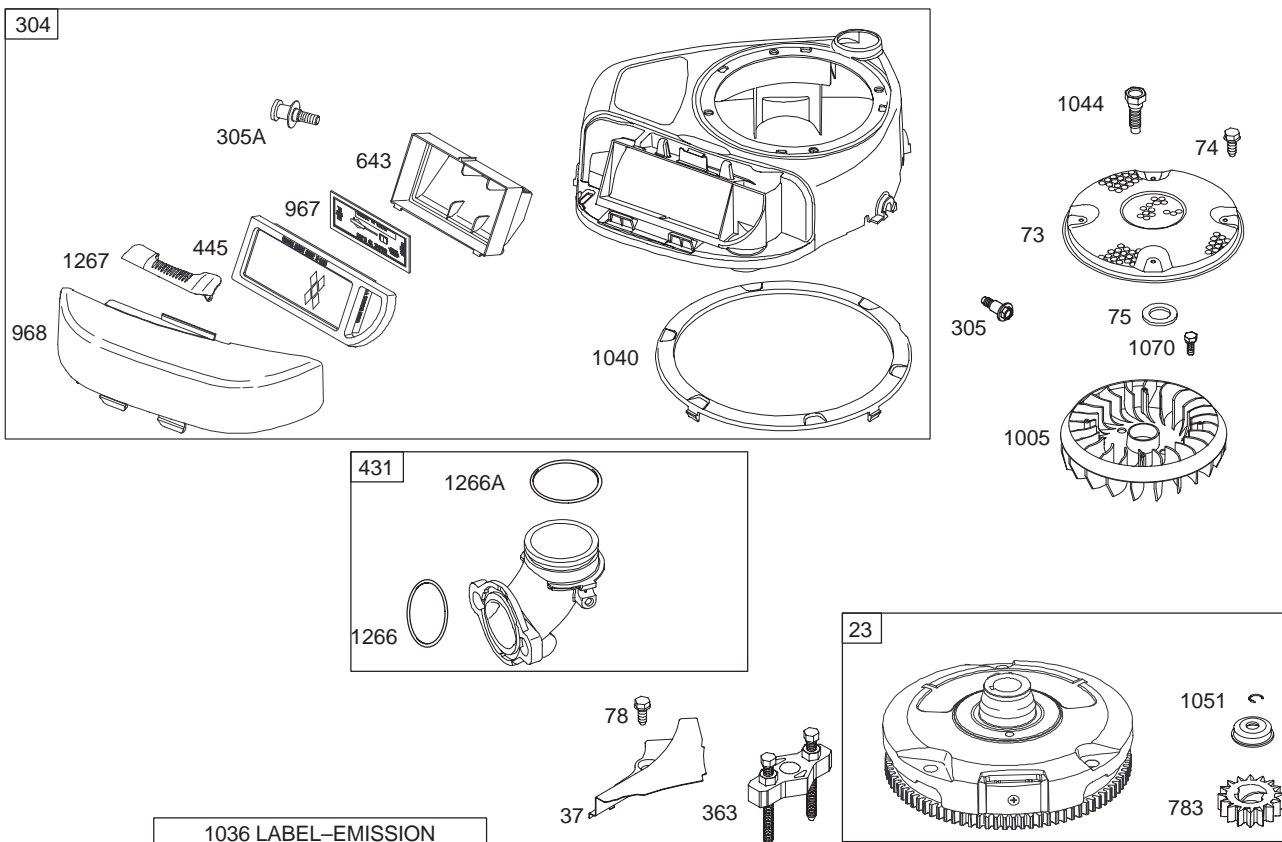

Assemblies include all parts shown in frames.

Blower Housing Assembly Engine Briggs and Stratton Model 280H07-0160-E1

Ref. No.	Part No.	Qty.	Description
23	693557	1	Flywheel
37	697352	1	Guard-Flywheel
73	697384	1	Screen-Rotating
74	690661	1	Screw (Rotating Screen)
75	690582	1	Washer (Flywheel)
78	691003	1	Screw (Flywheel Guard)
304	698599	1	Housing-Blower
305	697102	1	Screw (Blower Housing)
305A	697103	1	Screw (Blower Housing)
363	19203	1	Puller-Flywheel
431	697122	1	Elbow-Intake
445	698083	1	Filter-Air Cleaner Cartridge
643	698401	1	Retainer-Air Filter
783	693713	1	Gear-Pinion
967	697015	1	Filter-Pre Cleaner
968	698403	1	Cover-Air Cleaner
1005	697111	1	Fan-Flywheel

Ref. No.	Part No.	Qty.	Description
1036	695700	1	Label-Emission
1040	698368	1	Plate-Trim
1044	691658	1	Screw (Crankshaft Extension)
1051	691265	1	Ring-Retaining
1070	690372	1	Screw (Flywheel Fan)
★1266	691917	1	Seal-O Ring (Intake Elbow)
★1266A	697123	1	Seal-O Ring (Intake Elbow)
1267	697419	1	Latch-Blower Housing

★ Included in Engine Gasket Set-Ref. 358.

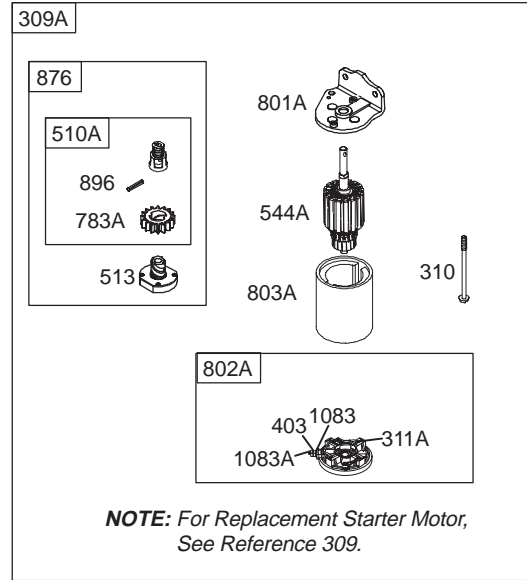
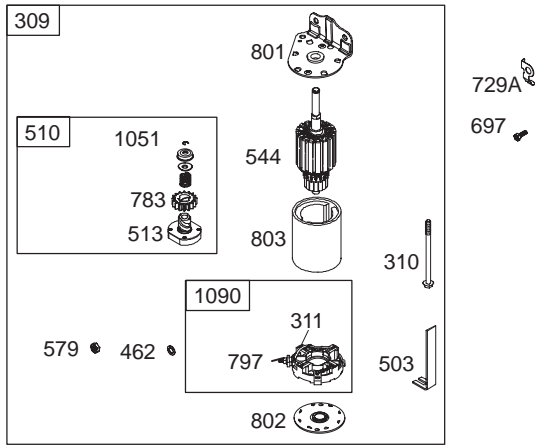

Starter Assembly Engine Briggs and Stratton Model 280H07-0160-E1

Ref. No.	Part No.	Qty.	Description
309	693551	1	Motor-Starter
309A		1	Motor-Starter (For Replacement Starter Motor, See Ref. 309)
310	690323	1	Bolt (Starter Motor)
311	497608	1	Brush Set
311A	395538	1	Brush Set
403	690288	1	Washer (End Cap)
462	691261	1	Washer (Brush Retainer)
503	691532	1	Strap-Starter
510	693699	1	Drive-Starter
510A	495878	1	Drive-Starter
513	692024	1	Drive Clutch
544	692034	1	Armature-Starter
544A	390837	1	Armature-Starter
579	691029	1	Nut (Brush Retainer)
697	690372	1	Screw (Drive Cap)
729A	691224	1	Clip-Wire

Ref. No.	Part No.	Qty.	Description
783	693713	1	Gear-Pinion
783A	693059	1	Gear-Pinion
797	693167	1	Nut (Brush Retainer)
801	691283	1	Cap-Drive
801A	691429	1	Cap-Drive
802	691286	1	Cap-End
802A	395537	1	Cap-End
803	693757	1	Housing-Starter
803A	398159	1	Housing-Starter
876	495877	1	Kit-Gear
896	691641	1	Pin-Drive Retainer
1051	691265	1	Ring-Retaining
1090	691293	1	Retainer-Brush
1083	690958	1	Nut (End Cap)
1083A	691626	1	Nut (End Cap)

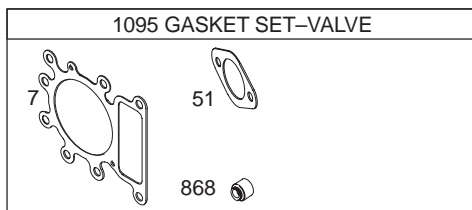
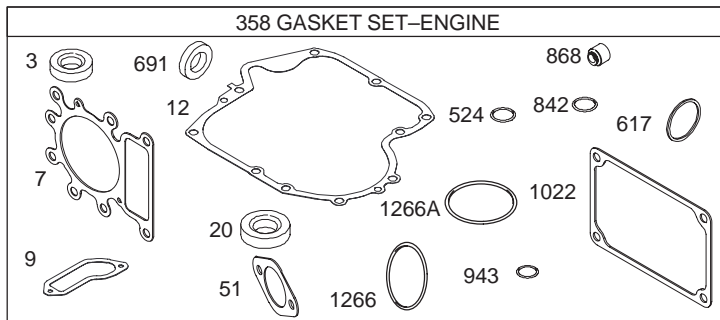

Assemblies include all parts shown in frames.

Gasket Assembly Engine Briggs and Stratton Model 280H07-0160-E1

Ref. No.	Part No.	Qty.	Description
★3	391086	1	Seal-Oil (Magneto Side)
★7	273280	1	Gasket-Cylinder Head
★9	697109	1	Gasket-Breather
★12	697110	1	Gasket-Crankcase
★20	690947	1	Seal-Oil (PTO Side)
★△◆♦51	692137	1	Gasket-Intake
358	697151	1	Gasket Set-Engine
★△◆617	692138	1	Seal-O Ring (Intake Manifold)
★524	691032	1	Seal-Dipstick Tube
★691	692407	1	Seal-Governor Shaft
★842	691031	1	Seal-O Ring (Dipstick Tube)
★△868	690968	1	Seal-Valve
★943	690589	1	Seal-O Ring (Oil Pump Cover)
★1022	272475	1	Gasket-Rocker Cover
1095	691581	1	Gasket Set-Valve
★◆1266	691917	1	Seal-O Ring (Intake Elbow)
★◆1266A	697123	1	Seal-O Ring (Intake Elbow)

Ref. No.	Part No.	Qty.	Description

△ Included in Valve Gasket Set-Ref. 1095.
★ Included in Engine Gasket Set-Ref. 358.

◆ Included in Carburetor Overhaul Kit-Ref. 121.
♦ Included in Carburetor Gasket Set-Ref. 977.

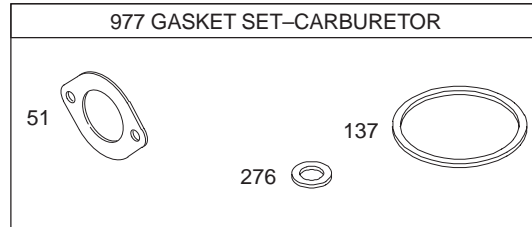
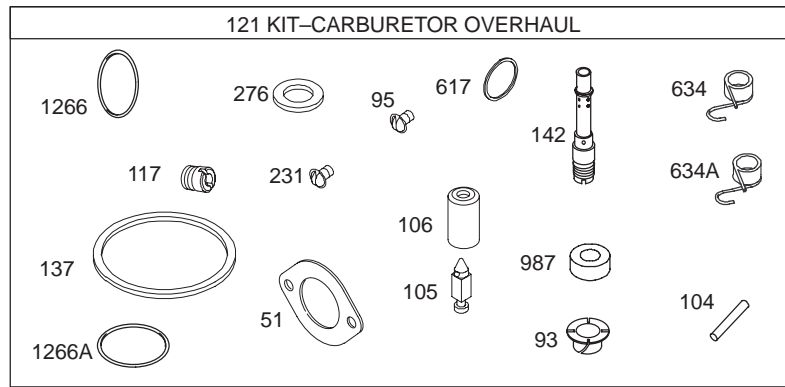

Assemblies include all parts shown in frames.

Carburetor Overhaul Kit Assembly Engine Briggs and Stratton Model 280H07-0160-E1

Ref. No.	Part No.	Qty.	Description
★△◆51	692137	1	Gasket-Intake
●93	690602	1	Bushing-Throttle Shaft
●95	691636	1	Screw (Throttle Valve)
●104	690525	1	Pin-Float Hinge
●105	231855	1	Valve-Float Needle
●106	690577	1	Seat-Inlet
●117	694352	1	Jet-Main (Standard)
121	697154	1	Kit-Carburetor Overhaul
◆137	281165	1	Gasket-Float Bowl
●142	697140	1	Nozzle-Carburetor
●231	691636	1	Screw (Choke Valve)
◆276	692255	1	Washer-Sealing
★●617	692138	1	Seal-O Ring (Intake Manifold)
●634	690801	1	Spring/Seal Assembly
●634A	690802	1	Spring/Seal Assembly
977	690192	1	Gasket Set-Carburetor
●987	691326	1	Seal-Throttle Shaft
★●1266	691917	1	Seal-O Ring (Intake Elbow)

Ref. No.	Part No.	Qty.	Description
★●1266A	697123	1	Seal-O Ring (Intake Elbow)

△ Included in Valve Gasket Set-Ref. 1095.

★ Included in Engine Gasket Set-Ref. 358.

● Included in Carburetor Overhaul Kit-Ref. 121.

◆ Included in Carburetor Gasket Set-Ref. 977.

