



Cyclone 1000 Debris Blower
Sand Pro[®]

Model No. 08857—Serial No. 230000001 and Up

Operator's Manual

Contents

	Page
Introduction	2
Safety	3
Before Operating	3
While Operating	3
Maintenance	3
Safety and Instruction Decals	5
Specifications	7
General Specifications	7
Optional Equipment	7
Setup	8
Install Wire Harness	9
Install Spline Shaft	10
Mount Bumper Assembly	10
Mount Blower	10
Install Drive Shaft	12
Grease Blower	12
Before Operating	13
Adjust Discharge Opening	13
Adjust Blower Housing Angle	13
Operation	14
Controls	14
Operating Tips	14
Lubrication	14
Grease Bearings & Bushings	14
Maintenance	15
Adjusting Belt	15
The Toro General Commercial Products Warranty ...	16

Introduction

Read this manual carefully to learn how to operate and maintain your product properly. The information in this manual can help you and others avoid injury and product damage. Although Toro designs and produces safe products, you are responsible for operating the product properly and safely.

Whenever you need service, genuine Toro parts, or additional information, contact an Authorized Service Dealer or Toro Customer Service and have the model and serial numbers of your product ready. The two numbers are stamped on a plate which is located on the rear of the blower housing.

Write the product model and serial numbers in the space below:

<p>Model No. _____</p> <p>Serial No. _____</p>
--

This manual identifies potential hazards and has special safety messages that help you and others avoid personal injury and even death. **Danger**, **Warning**, and **Caution** are signal words used to identify the level of hazard. However, regardless of the hazard, be extremely careful.

Danger signals an extreme hazard that *will* cause serious injury or death if you do not follow the recommended precautions.

Warning signals a hazard that *may* cause serious injury or death if you do not follow the recommended precautions.

Caution signals a hazard that may cause minor or moderate injury if you do not follow the recommended precautions.

This manual uses two other words to highlight information.

Important calls attention to special mechanical information and **Note**: emphasizes general information worthy of special attention.

Safety

Hazard control and accident prevention are dependent upon the awareness, concern, and proper training of the personnel involved in the operation, transport, maintenance, and storage of the machine. Improper use or maintenance of the machine can result in injury or death. To reduce the potential for injury or death, comply with the following safety instructions.

Before Operating

- Read and understand the contents of this Operator's Manual before operating the machine. Become familiar with all of the controls and know how to stop quickly. A free replacement manual is available by sending the complete Model and Serial Number to The Toro Company, 8111 Lyndale Avenue South, Bloomington, Minnesota 55420-1196.
- Never allow children to operate the machine. Do not allow adults to operate machine without proper instruction. Only trained operators who have read this manual should operate this machine.
- Never operate the machine when under the influence of drugs or alcohol.
- Keep all bystanders away from the operating area.
- Keep all shields and safety devices in place. If a shield, safety device, or decal is illegible or damaged, repair or replace it before operation is commenced. Also tighten any loose nuts, bolts, and screws to ensure that the machine is in safe operating condition.
- Do not operate the machine while wearing sandals, tennis shoes, sneakers, or shorts. Also, do not wear loose fitting clothing which could get caught in moving parts. Always wear long pants and substantial shoes. Wearing safety glasses, safety shoes, and a helmet is advisable and required by some local ordinances and insurance regulations.

While Operating

- Do not run the engine in a confined area without adequate ventilation. Exhaust fumes are hazardous and could possibly be deadly.
- The maximum seating capacity is one person. Never carry passengers.
- Sit on the seat when starting the engine and operating the machine.
- This product may exceed noise levels of 90 dB(A) at the operator position. Ear protectors are recommended for prolonged exposure to reduce the potential of permanent hearing damage.

- Using the machine demands attention. To prevent loss of control:
 - Operate only in daylight or when there is good artificial light.
 - Drive slowly and watch for holes or other hidden hazards.
 - Do not drive close to a sand trap, ditch, creek, or other hazard.
 - Reduce your speed when making sharp turns and when turning on hillsides.
 - Avoid sudden starts and stops.
 - Before backing up, look to the rear and ensure that no one is behind the machine.
 - Watch out for traffic when near or crossing roads. Always yield the right-of-way.
- Stay away from the discharge opening when the machine is operating. Keep all bystanders away from the discharge opening and don't direct discharge toward bystanders.
- If the engine stalls or the machine loses headway and cannot make it to the top of a slope, do not turn the machine around. Always back slowly straight down the slope.
- **Do not take an injury risk!** When a person or pet appears unexpectedly in or near the operating area, **stop operation.** Careless operation, combined with terrain angles, ricochets, or improperly positioned guards can lead to thrown object injuries. Do not resume operation until the area is cleared.
- Do not touch the engine or muffler while the engine is running or soon after it is stopped. These areas could be hot enough to cause a burn.

Maintenance

- Remove the key from the ignition switch to prevent accidental starting of the engine when servicing, adjusting, or storing the machine.
- Perform only those maintenance instructions described in this manual. If major repairs are ever needed or assistance is desired, contact an Authorized Toro Distributor.
- To reduce a potential fire hazard, keep the engine free of excessive grease, grass, leaves, and accumulations of dirt. Never wash a warm engine or any electrical parts with water.
- Be sure that the machine is in safe operating condition by keeping nuts, bolts, and screws tight. Check the rotor bearing mounting bolts and nuts frequently to be sure that they are tightened to specification.

- Make sure that all hydraulic line connectors are tight and all hydraulic hoses and lines are in good condition before applying pressure to the system.
- Keep your body and hands away from pin hole leaks in hydraulic lines that eject high pressure hydraulic fluid. Use cardboard or paper to find hydraulic leaks. Hydraulic fluid escaping under pressure can penetrate skin and cause injury. Fluid accidentally injected into the skin must be surgically removed within a few hours by a doctor familiar with this form of injury or gangrene may result.
- Before disconnecting or performing any work on the hydraulic system, all pressure in the system must be relieved by stopping the engine and lowering the blower to the ground.
- If the engine must be running to perform a maintenance adjustment, keep hands, feet, clothing, and other parts of the body away from the fan and other moving parts.
- Do not overspeed the engine by changing the governor settings. To be sure of safety and accuracy, have an Authorized Toro Distributor check the maximum engine speed with a tachometer.
- The engine must be shut off before checking the oil or adding oil to the crankcase.
- At the time of manufacture, the blower conformed to safety standards in effect for riding mowers; therefore, to ensure optimum performance and safety, always purchase genuine Toro replacement parts and accessories to keep the machine all Toro. **Never use “will-fit” replacement parts and accessories made by other manufacturers.** Look for the Toro logo to ensure genuineness. Using unapproved replacement parts and accessories could void the warranty.

Safety and Instruction Decals



Safety decals and instructions are easily visible to the operator and are located near any area of potential danger. Replace any decal that is damaged or lost.



98-3110

1. Warning—read the *Operator's Manual* and receive training.
2. Warning—wear hearing protection.
3. Thrown object hazard—wear eye protection and keep bystanders a safe distance from the machine.
4. Cutting hazard of hand or foot—wait for moving parts to stop.



98-3111

1. Point of rotation

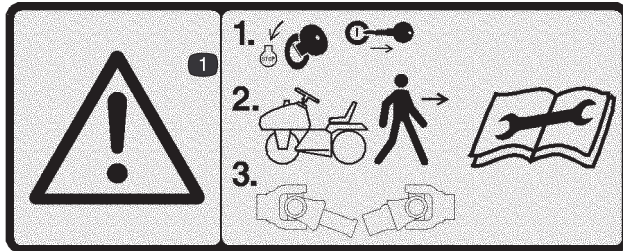

98-3113

1. Warning—stop the engine and remove the key before leaving the machine or disconnecting the PTO shaft; read the instructions before servicing or performing maintenance.

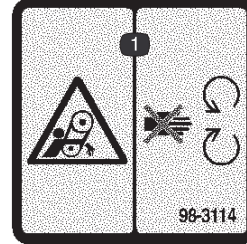

98-3114

1. Entanglement hazard—stay away from moving parts.

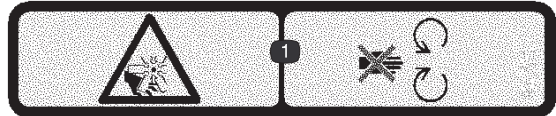

93-9083

1. Cutting/dismemberment hazard, fan—stay away from moving parts.



93-6674

1. Crushing hazard, hand—read the instructions before servicing or performing maintenance.

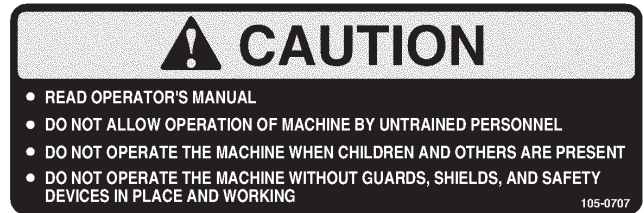

105-0707

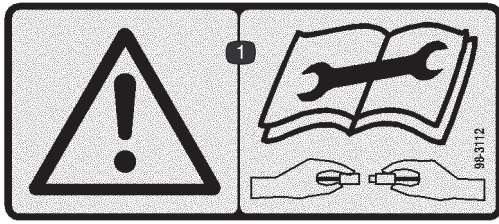

98-3112

1. Warning—read the instructions before servicing or performing maintenance on the electrical wiring.

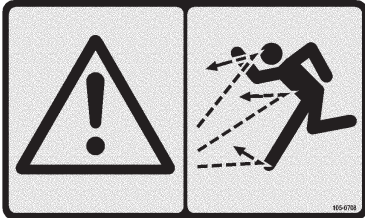

105-0708

1. Warning—thrown objects

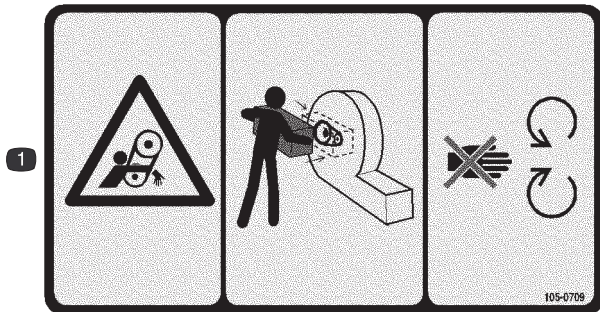

105-0709

1. Entanglement hazard, belt—place the guard over the belt and stay away from moving parts.



98-3115

1. Rotating shaft

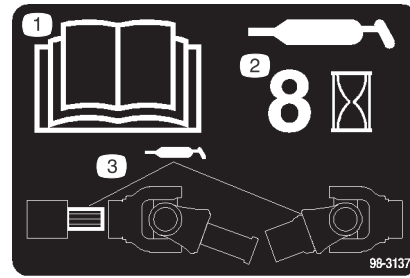

105-3137

1. Read the *Operator's Manual*.
2. Grease every 8 hours.
3. Add grease here.

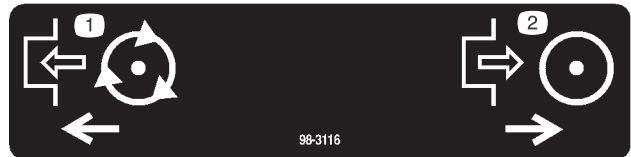

98-3116

1. Engage
2. Disengage

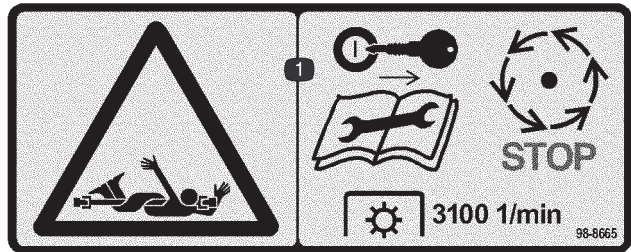

98-8665

1. Entanglement hazard, shaft—remove the ignition key, wait for moving parts to stop, and read the instructions before servicing or performing maintenance; the PTO revolves at 3100 rpm.

Specifications

Note: Specifications and design subject to change without notice.

General Specifications

Fan	Backward curved, cast aluminum fan. 12 blades per side, 21" outside diameter, 6.375" width, 34 lbs.
Fan Housing	10 gauge steel face plates welded to 10 gauge wrapper. Increasing scroll from cutoff.
Fan Drive	PTO driven single B section belt drive to fan. Final drive ratio of 1.4:1 with a over running clutch pulley on input shaft. PTO and fan shaft rotate on greaseable ball bearing.
Fan Speed	2100 rpm
Fan Output	2850 CFM, 85 mph.
Outlet	Outlet opening is 46 square in. with adjustable discharge deflector.
Weight	180 lbs.

Optional Equipment

Discharge Chute Kit

Model No. 08860

Setup

Note: Use this chart as a checklist to ensure that all parts have been received. Without these parts, total setup cannot be completed.

Description	Qty.	Use
Blower Assembly	1	Mounting
*Relay	1	Mount to Sand Pro frame
*Capscrew #10–24 x .38" lg.	1	Connect neutral switch wire to harness
*Nut #10–24	1	
*Wire Harness	1	Connect to relay, solenoid & blower
*Wire Tie	4	
*Spline Shaft	1	Mount spline shaft to output shaft
*Key	1	
*Square Head Setscrew	2	
*Power Take–Off Cover	1	
*Capscrew 3/8–16 x .50" lg. (Sand Pro 2020/3020)	2	
(Sand Pro 5000/5020 only)	4	
*Flat Washer .40 I.D. x .81 O.D. (Sand Pro 2020/3020)	2	
(Sand Pro 5000/5020 only)	4	
*Receiver Bracket	2	Mount to Sand Pro frame
*Capscrew 3/8–16 x 1.25" lg. (Sand Pro 2020/3020 only)	2	
*Capscrew 3/8–16 x 1.50" lg. (Sand Pro 5000/5020 only)	2	
*Flat Washer .40 I.D. x .81 O.D.	2	
*Locknut 3/8–16	2	
*Capscrew 1/2–13 x .875" lg.	2	
*Flat Washer .56 I.D. x 1.063 O.D.	2	
*Spacer .25" Thk. (Sand Pro 2020/3020 w/ fenders only)	2	
*Spacer .625" lg. (Sand Pro 5000/5020 only)	2	
*Spacer .375" lg. (Sand Pro 5000/5020 w/ matt rack only)	2	
Bumper Assembly	1	Mount to blower frame
Capscrew 3/8–16 x 2.00"	4	
Flat Washer .40 I.D. x .81 O.D.	4	
Locknut 3/8–16	4	

Description	Qty.	Use
Hitch	2	Mount to blower frame
Capscrew 3/8–16 x 2" lg.	8	
Flat Washer .40 I.D. x .81 O.D.	16	
Spacer	8	
Locknut 3/8–16	8	
*Clevis pin	2	Secure blower to Sand Pro
*Hair Pin Cotter	2	
*Drive Shaft	1	Mount Drive Shaft to Blower
Operator's Manual	1	Read before operating the machine.
Parts Catalog	1	
Registration card	1	Fill out and return to Toro.

Note: Determine the left and right sides of the machine from the normal operating position.

Note: One of the following installation kits is required to mount the debris blower to the Sand Pro.

- Kit Model No. 08858 for Sand Pro 2020 & 3020
- Kit Model No. 08859 for Sand Pro 5000 & 5020

Install Wire Harness

1. Mount the relay and wire harness (supplied in installation kit) to Sand Pro as follows:
 - On Sand Pro 2020/3020 only – Remove nut from capscrew securing steering bracket to frame. Insert relay and black wire from harness onto capscrew and install nut (Fig. 1).

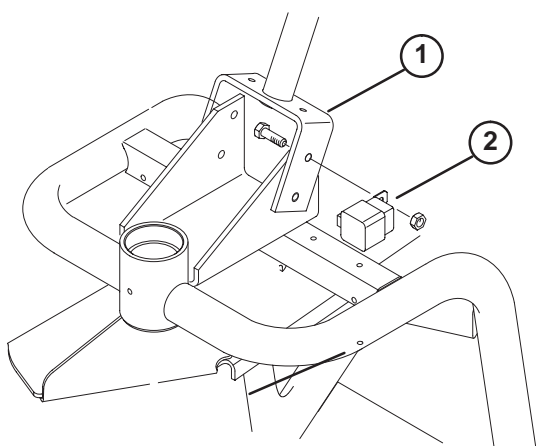

Figure 1

1. Steering bracket 2. Relay

- On Sand Pro 5000/5020 only – Remove nut from capscrew securing solenoid to frame panel. Insert relay and black wire from harness onto capscrew and install nut (Fig. 2).

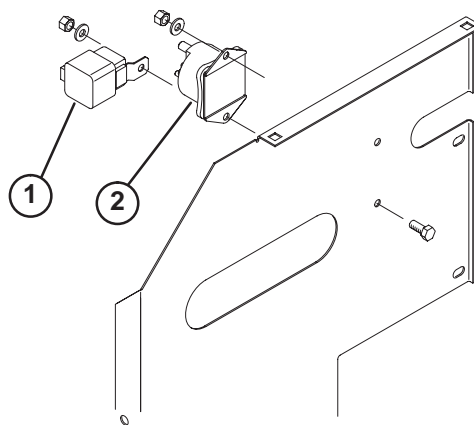
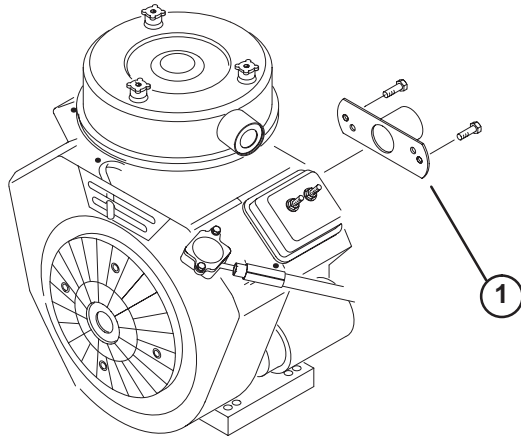

Figure 2

1. Relay
2. Disconnect gray wire (neutral switch) from solenoid and connect to blue wire on harness with #10–24 x .38" capscrew and nut. Wrap connection with electrical tape.
3. Connect gray harness wire to solenoid post that grey neutral switch wire was connected.
4. Connect orange harness wire to solenoid post that has a green wire attached to it.
5. Plug wire harness connector into relay.
6. Route wire harness to right rear corner of Sand Pro frame. Secure harness and any excess to frame with wire ties. Make sure harness does not contact any hot or moving parts.

Install Spline Shaft

1. Remove fasteners securing output shaft cover to rear of engine on Sand Pro 5000/5020 (Fig. 3) or to rear of hydrostat on Sand Pro 2020/3020. Remove and discard cover.



Sand Pro 5000 Shown

Figure 3

1. Output shaft cover

2. Mount spline shaft (supplied in installation kit) to output shaft with key and (2) square head set screw. Apply Loctite to set screw threads and Never-Seez to output shaft before installation. Torque set screws to 140 in/lb (Fig. 4).

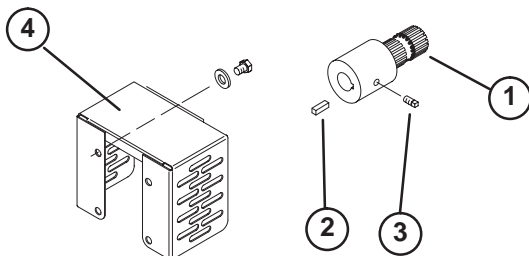

Figure 4

1. Spline shaft
2. Key
3. Square head setscrew
4. Power take-off cover (Sand Pro 5000/5020 cover shown)

3. Using old output shaft cover mounting holes, mount new power take-off cover (supplied in installation kit) with (2) 3/8-16 x .50" lg. capscrews and .40 I.D. x .81 O.D. flat washers (Fig. 4).

Mount Bumper Assembly

1. Mount bumper assembly to blower with (4) 3/8-16 x .50" Lg. capscrews, .40 I.D. x .81 O.D. flatwashers and locknuts (Fig. 5).

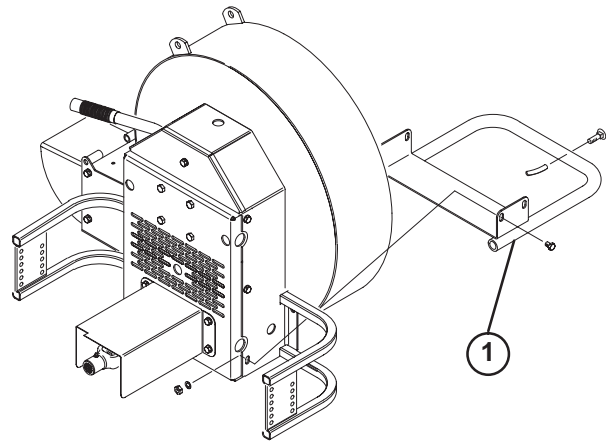

Figure 5

1. Bumper assembly

Mount Blower

1. Mount a receiver bracket (supplied in installation kit) to each end Sand Pro rear frame member as follows:
 - On Sand Pro 2020/3020 – Mount top of receiver bracket to frame with a 3/8-16 x 1.50" lg. capscrew, (2) .40 I.D. x .81 O.D. flat washers and locknut. Mount bottom of receiver bracket to frame with a 1/2-13 x .875" lg. capscrews and (2) .56 I.D. x 1.063 O.D. flat washers. Position components as shown in figure 6.

Note: Spacer, shown in figure 6, is also required If machine is equipped with fenders.

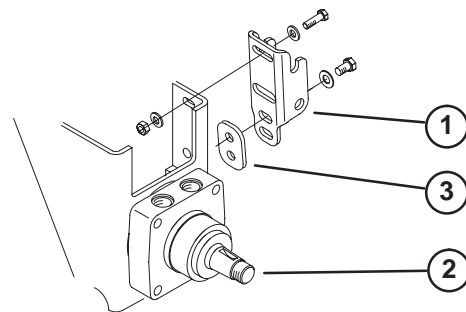

Figure 6

1. Receiver bracket
2. Left rear wheel motor
3. Spacer

Note: Rear wheel shown removed for clarity. Do not remove rear wheel.

- On Sand Pro 5000/5020 – Mount top of receiver bracket to frame with a 3/8–16 x 1.25” lg. capscrew, (2) .40 I.D. x .81 O.D. flat washers, .625” lg. spacer and locknut. Mount bottom of receiver bracket to frame with a 1/2–13 x .875” lg. capscrew and (2) .56 I.D. x 1.063 O.D. flat washers. Position components as shown in figure 7.

Note: Use .375” lg. spacers instead of .625 lg. spacers when machine is equipped with matt rack.

Note: Rear wheel shown removed for clarity. Do not remove rear wheel.

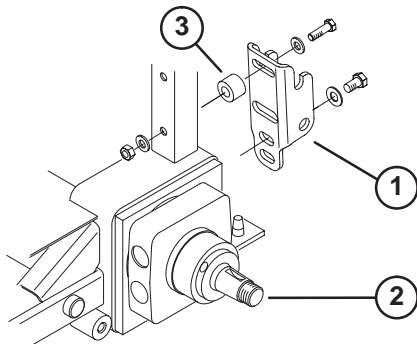

Figure 7

- | | |
|--------------------------|-----------|
| 1. Receiver bracket | 3. Spacer |
| 2. Left rear wheel motor | |

- Slide a hitch onto each side of blower frame. Use forward set of hitch mounting holes when mounting blower on a Sand Pro 2020 or Sand Pro 3020 and rear set of holes for a Sand Pro 5000/5020. Secure hitch to blower frame with (4) 3/8–16 x 2” lg. capscrews, .40 I.D. x .69 O.D. flatwashers and (8) spacers. Spacers to be positioned between frame and hitch on each side (Fig. 8).

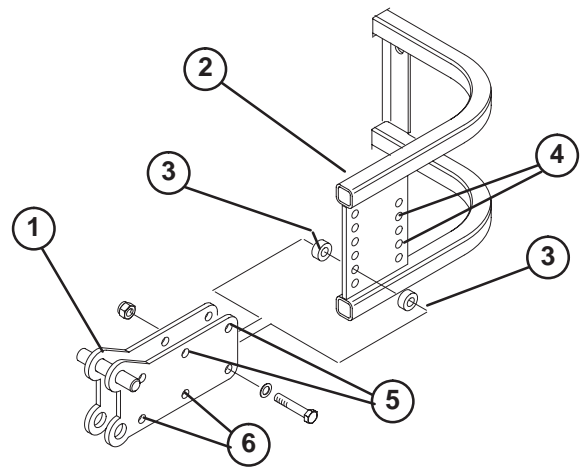

Figure 8

- | | |
|----------------------|-------------------------------|
| 1. Hitch | 5. Use for Sand Pro 5000/5020 |
| 2. Blower frame | 6. Use for Sand Pro 2020/3020 |
| 3. Spacer | |
| 4. Recommended holes | |

- Lift blower and position hitch pins into slots on top of receiver brackets on Sand Pro (Fig. 9).

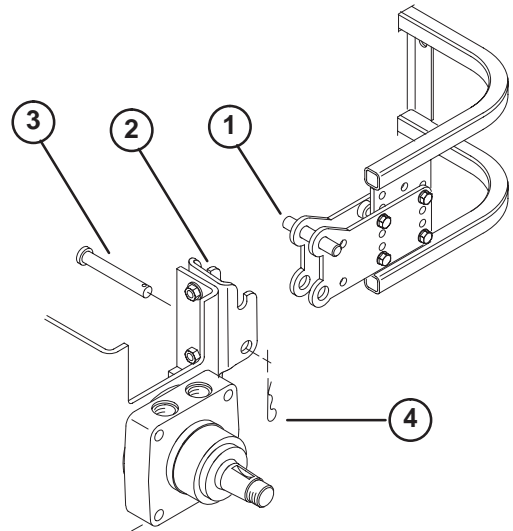

Figure 9

- | | |
|---------------------|-------------------|
| 1. Hitch pin | 3. Clevis pin |
| 2. Receiver bracket | 4. Hairpin cotter |

- Secure each hitch to receiver bracket with a clevis pin and hair pin cotter.

Install Drive Shaft

1. Insert drive shaft spline (supplied in installation kit) into blower coupler (Fig. 10).
2. Rotate shaft until splines line up.

Note: To aid in the rotation of drive shaft, insert screw driver into universal joint.

3. Slide drive shaft coupler onto spline shaft until it clicks.

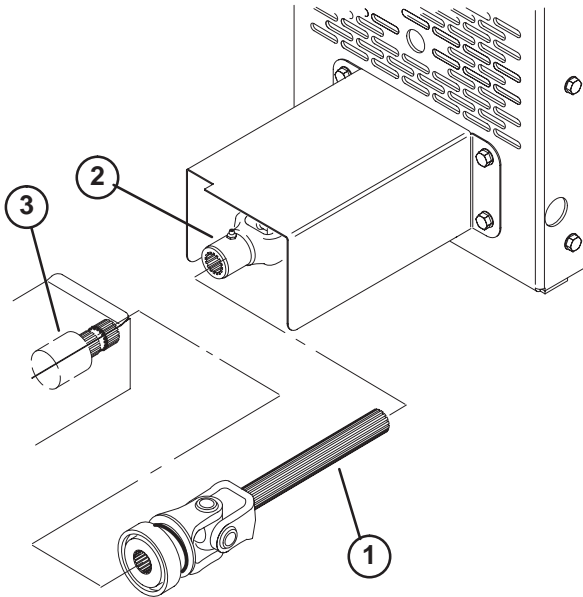

Figure 10

1. Drive shaft
2. Blower coupler
3. Spline shaft

Grease Blower

Before the Debris Blower is operated, it must be greased to assure proper lubrication. Refer to Lubrication section of manual. Failure to properly grease the unit will result in premature failure of critical parts.

4. Plug wire harness into blower harness.

Before Operating

Adjust Discharge Opening

The discharge opening (Fig. 11) is adjustable to increase or decrease air output velocity and volume. Decreasing discharge opening size will increase velocity.

1. Loosen discharge opening deflector mounting screws.
2. Pivot deflector to desired opening.
3. Tighten mounting screws.

Adjust Blower Housing Angle

The blower housing angle (Fig. 11) is adjustable to raise or lower the discharge opening of the blower.

1. Remove capscrew securing cover to rear of blower housing.
2. Loosen (4) blower housing mounting screws. Through (3) holes in rear bracket and behind cover
3. Pivot blower housing to desired angle.
4. Tighten mounting screws and install cover.

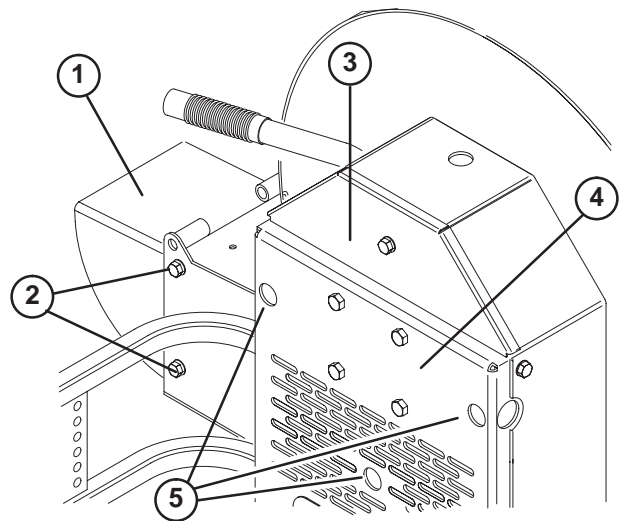

Figure 11

- | | |
|--------------------------------|---------------------|
| 1. Discharge opening deflector | 3. Cover |
| 2. Deflector mounting screws | 4. Rear bracket |
| | 5. Adjustment holes |

Operation

Controls

Clutch Engagement Lever

Pull lever (Fig. 12) upward to engage clutch, push lever downward to disengage clutch.

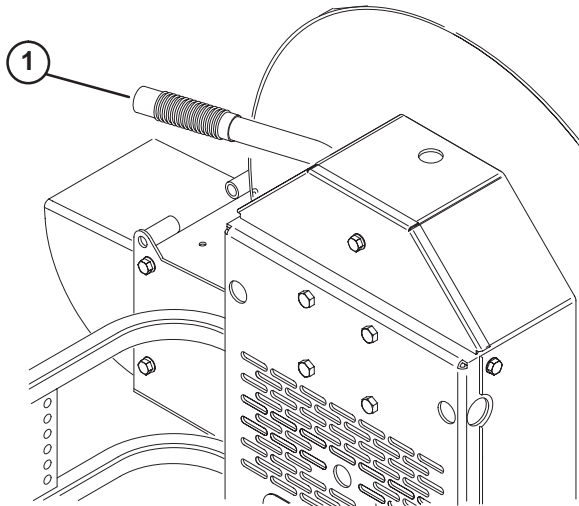

Figure 12

1. Clutch engagement lever

Operating Tips



Warning



Discharged air has considerable force and could cause injury or loss of footing.

- Stay away from discharge opening when machine is operating.
- Keep bystanders away from discharge opening when machine is running.

Practice blowing material. It is advisable to blow the same direction the wind is blowing to prevent material from blowing back into the cleared area.

Lubrication

Grease Bearings & Bushings

The debris blower must be lubricated regularly. If machine is operated under normal conditions, lubricate castor and fan bearings and bushings with No. 2 general purpose lithium base grease or molybdenum base grease, after every 8 hours of operation or daily, whichever comes first. Lubricate fittings immediately after every washing, regardless of the interval listed.

The debris blower has (6) bearings and bushings that must be lubricated (Fig. 13). The lubrication points are: fan shaft bearings (2), drive shaft bearings (2), over running clutch (1) and PTO drive shaft (2).

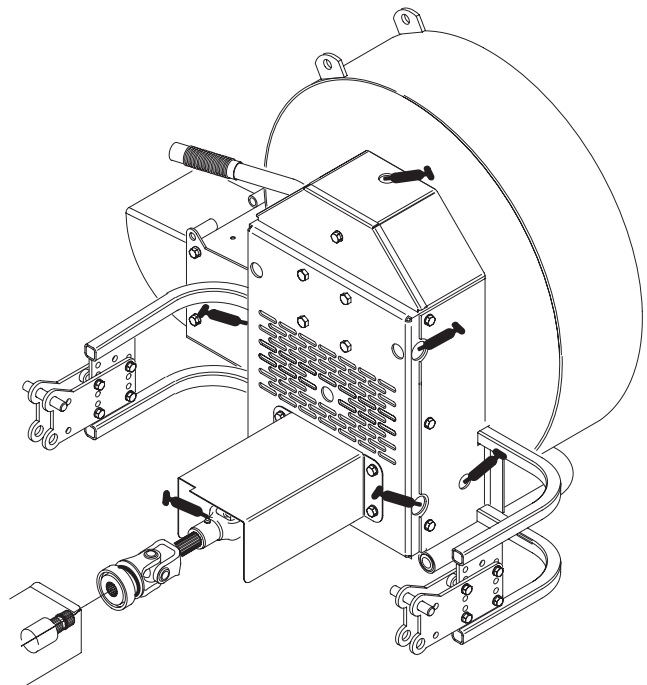

Figure 13

Maintenance

Adjusting Belt

1. Remove capscrews, flatwashers and locknuts securing bumper assembly to blower (Fig. 14). Remove bumper assembly.

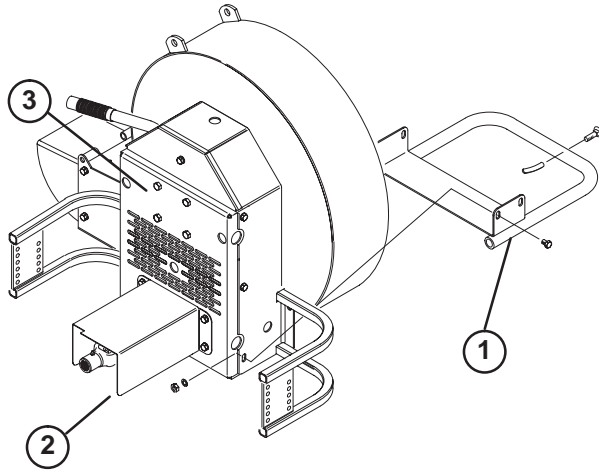

Figure 14

1. Bumper assembly
2. P.T.O. cover
3. Back cover assembly

2. Unplug wire harness from blower harness.
3. Disconnect drive shaft coupler from spline shaft.
4. Remove clevis pins and hair pin cotters securing blower hitches to receiver brackets. Remove blower from traction unit.
5. Lay blower onto front screen so mounting hitches point upward.
6. Remove capscrews and flatwashers securing P.T.O. cover to back cover assembly of blower (Fig. 14). Remove P.T.O. cover.
7. Remove (8) capscrews and locknuts securing fan shaft bearing and P.T.O. shaft bearing assemblies to inside of back cover assembly (Fig. 15). **Do not remove bearings from shafts.**
8. Remove (6) capscrews and flatwashers securing back cover assembly to blower (Fig. 15). Remove back cover assembly from blower.

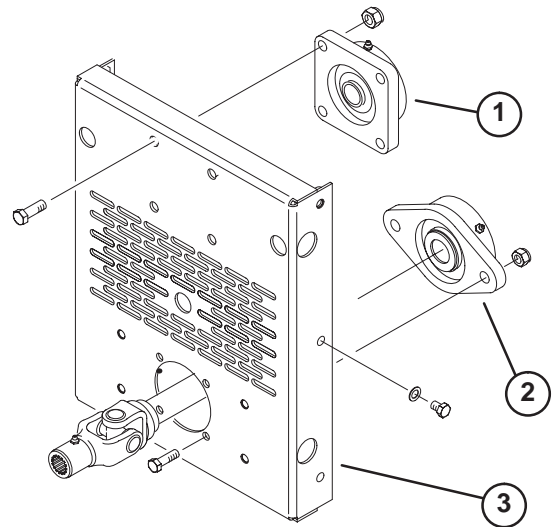

Figure 15

1. Fan shaft bearing
2. P.T.O. shaft bearing
3. Back cover assembly

9. Replace belt. Make sure belt is routed around fan and P.T.O. pulleys and against idler pulley (Fig. 16).

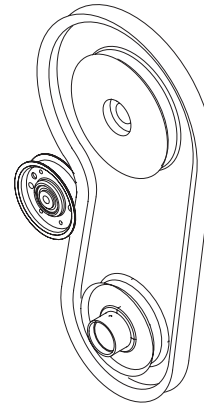

Figure 16

10. Loosely install back cover assembly to blower with (6) capscrews and flatwashers previously removed.
11. Install bearing assemblies to inside of back cover assembly with (8) capscrews and locknuts previously removed.
12. Rotate fan to check for any interference between fan and fan housing. Move back cover assembly forward or backward to gain required clearance and tighten (6) capscrews and flatwashers securing back cover assembly to blower.



The Toro General Commercial Products Warranty

A Two-Year Limited Warranty

Conditions and Products Covered

The Toro Company and its affiliate, Toro Warranty Company, pursuant to an agreement between them, jointly warrant your 1996 or newer Toro Commercial Product ("Product") purchased after January 1, 1997, to be free from defects in materials or workmanship for two years or 1500 operational hours*, whichever occurs first. Where a warrantable condition exists, we will repair the Product at no cost to you including diagnosis, labor, parts, and transportation. This warranty begins on the date the Product is delivered to the original retail purchaser.

* Product equipped with hour meter

Instructions for Obtaining Warranty Service

You are responsible for notifying the Commercial Products Distributor or Authorized Commercial Products Dealer from whom you purchased the Product as soon as you believe a warrantable condition exists.

If you need help locating a Commercial Products Distributor or Authorized Dealer, or if you have questions regarding your warranty rights or responsibilities, you may contact us at:

Toro Commercial Products Service Department
Toro Warranty Company
8111 Lyndale Avenue South
Bloomington, MN 55420-1196
952-888-8801 or 800-982-2740
E-mail: commercial.service@toro.com

Owner Responsibilities

As the Product owner, you are responsible for required maintenance and adjustments stated in your operator's manual. Failure to perform required maintenance and adjustments can be grounds for disallowing a warranty claim.

Items and Conditions Not Covered

Not all product failures or malfunctions that occur during the warranty period are defects in materials or workmanship. This express warranty does not cover the following:

- Product failures which result from the use of non-Toro replacement parts, or from installation and use of add-on, modified, or unapproved accessories
- Product failures which result from failure to perform required maintenance and/or adjustments
- Product failures which result from operating the Product in an abusive, negligent or reckless manner
- Parts subject to consumption through use unless found to be defective. Examples of parts which are consumed, or used up, during normal Product operation include, but are not limited to, blades, reels, bedknives, tines, spark plugs, castor wheels, tires, filters, belts, etc.

- Failures caused by outside influence. Items considered to be outside influence include, but are not limited to, weather, storage practices, contamination, use of unapproved coolants, lubricants, additives, or chemicals, etc.
- Normal "wear and tear" items. Normal "wear and tear" includes, but is not limited to, damage to seats due to wear or abrasion, worn painted surfaces, scratched decals or windows, etc.

Parts

Parts scheduled for replacement as required maintenance are warranted for the period of time up to the scheduled replacement time for that part.

Parts replaced under this warranty become the property of Toro. Toro will make the final decision whether to repair any existing part or assembly or replace it. Toro may use factory remanufactured parts rather than new parts for some warranty repairs.

General Conditions

Repair by an Authorized Toro Distributor or Dealer is your sole remedy under this warranty.

Neither The Toro Company nor Toro Warranty Company is liable for indirect, incidental or consequential damages in connection with the use of the Toro Products covered by this warranty, including any cost or expense of providing substitute equipment or service during reasonable periods of malfunction or non-use pending completion of repairs under this warranty. Except for the Emissions warranty referenced below, if applicable, there is no other express warranty. All implied warranties of merchantability and fitness for use are limited to the duration of this express warranty.

Some states do not allow exclusions of incidental or consequential damages, or limitations on how long an implied warranty lasts, so the above exclusions and limitations may not apply to you.

This warranty gives you specific legal rights, and you may also have other rights which vary from state to state.

Note regarding engine warranty: The Emissions Control System on your Product may be covered by a separate warranty meeting requirements established by the U.S. Environmental Protection Agency (EPA) and/or the California Air Resources Board (CARB). The hour limitations set forth above do not apply to the Emissions Control System Warranty. Refer to the Engine Emission Control Warranty Statement printed in your operator's manual or contained in the engine manufacturer's documentation for details.

Countries Other than the United States or Canada

Customers who have purchased Toro products exported from the United States or Canada should contact their Toro Distributor (Dealer) to obtain guarantee policies for your country, province, or state. If for any reason you are dissatisfied with your Distributor's service or have difficulty obtaining guarantee information, contact the Toro importer. If all other remedies fail, you may contact us at Toro Warranty Company.