



**Z147**

**Z Master<sup>®</sup> with 44" SFS Side Discharge Mower**

**Model No. 74176—Serial No. 230000001 and Up**

*PROTOTYPE*

**Operator's Manual**



## Warning



The engine exhaust from this product contains chemicals known to the State of California to cause cancer, birth defects, or other reproductive harm.

**Important** This engine is not equipped with a spark arrester muffler. It is a violation of California Public Resource Code Section 4442 to use or operate this engine on any forest-covered, brush-covered or grass-covered land. Other states or federal areas may have similar laws.

This spark ignition system complies with Canadian ICES-002.

Ce système d'allumage par étincelle de véhicule est conforme à la norme NMB-002 du Canada.

The enclosed Engine Owner's Manual is supplied for information regarding The U.S. Environmental Protection Agency (EPA) and the California Emission Control Regulation of emission systems, maintenance and warranty.

Keep this engine Owner's Manual with your unit. Should this engine Owner's Manual become damaged or illegible, replace immediately. Replacements may be ordered through the engine manufacturer.

# Contents

	Page
Introduction .....	3
Safety .....	3
Safe Operating Practices .....	3
Toro Mower Safety .....	5
Slope Chart .....	7
Safety and Instruction Decals .....	9
Gasoline and Oil .....	13
Recommended Gasoline .....	13
Using Stabilizer/Conditioner .....	13
Filling the Fuel Tank .....	13
Check Engine Oil Level .....	13
Setup .....	14
Loose Parts .....	14
Installing the Drive Wheels .....	14
Tire Pressure .....	14
Installing the Seat Retaining Rod .....	14
Installing the Motion Control Levers .....	15
Activating the Battery .....	15
Checking the Hydraulic Fluid .....	16
Greasing the Bearings .....	16
Check the Level of Mower .....	17

	Page
Check Side Discharge Chute .....	17
Check Engine Oil Level .....	17
Operation .....	17
Think Safety First .....	17
Controls .....	17
Operating the Parking Brake .....	18
Using the Blowout Baffles .....	18
Starting and Stopping the Engine .....	18
Operating the Power Take Off (PTO) .....	20
The Safety Interlock System .....	20
Testing the Safety Interlock System .....	20
Driving Forward or Backward .....	20
Stopping the Machine .....	21
Adjusting the Height-of-Cut .....	21
Adjusting Anti-Scalp Rollers .....	22
Positioning the Seat .....	23
Pushing the Machine by Hand .....	23
Using a Rollover Protection System .....	23
Operating with Side Discharge .....	23
Transporting Machines .....	24
Loading Machines .....	24
Tips for Mowing Grass .....	25
Maintenance .....	26
Recommended Maintenance Schedule .....	26
Servicing the Cutting Blades .....	27
Servicing the Air Cleaner .....	29
Servicing the Engine Oil .....	30
Servicing the Spark Plug .....	31
Servicing the Fuel Filter .....	32
Servicing the Fuel Tank .....	32
Cleaning the Cooling System .....	33
Greasing and Lubrication .....	33
Greasing the Bearings .....	34
Checking the Tire Pressure .....	34
Adjusting the Wheel Hub Slotted Nut .....	35
Adjusting the Caster Pivot Bearing .....	35
Servicing the Hydraulic System .....	35
Adjusting the Handle Neutral .....	37
Setting the Hydraulic Pump Neutral .....	39
Adjusting the Tracking .....	40
Adjusting the Parking Brake .....	40
Servicing the Fuse .....	41
Servicing the Battery .....	41
Adjusting the Mower Level .....	43
Cleaning Under the Deck .....	44
Adjusting the Push Arms .....	45
Inspecting the Belts .....	45
Replacing the Deck Belt .....	45
Replacing the Pump Drive Belt .....	46

	Page
Replacing the Grass Deflector . . . . .	46
Waste Disposal . . . . .	47
Mercury Tilt Switch . . . . .	47
Mercury Tilt Switch Disposal . . . . .	47
Wiring Diagram . . . . .	48
Cleaning and Storage . . . . .	49
Troubleshooting . . . . .	50
The Toro Total Coverage Guarantee . . . . .	56

# Introduction

Read this manual carefully to learn how to operate and maintain your product properly. The information in this manual can help you and others avoid injury and product damage. Although Toro designs and produces safe products, you are responsible for operating the product properly and safely.

Whenever you need service, genuine Toro parts, or additional information, contact an Authorized Service Dealer or Toro Customer Service and have the model and serial numbers of your product ready. Figure 1 illustrates the location of the model and serial numbers on the product.

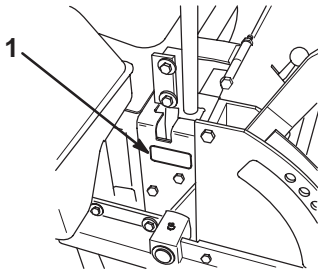

m-3648

**Figure 1**

1. Location of the model and serial numbers

Write the product model and serial numbers in the space below:

<b>Model No.</b> _____
<b>Serial No.</b> _____

This manual identifies potential hazards and has special safety messages that help you and others avoid personal injury and even death. **Danger**, **Warning**, and **Caution** are signal words used to identify the level of hazard. However, regardless of the hazard, be extremely careful.

**Danger** signals an extreme hazard that *will* cause serious injury or death if you do not follow the recommended precautions.

**Warning** signals a hazard that *may* cause serious injury or death if you do not follow the recommended precautions.

**Caution** signals a hazard that may cause minor or moderate injury if you do not follow the recommended precautions.

This manual uses two other words to highlight information. **Important** calls attention to special mechanical information and **Note**: emphasizes general information worthy of special attention.

# Safety

**This machine meets or exceeds the B71.4 1999 specifications of the American National Standards Institute, in effect at time of production.**

**Note:** The addition of attachments made by other manufacturers that do not meet American National Standards Institute certification will cause noncompliance of this machine.

**Improper use or maintenance by the operator or owner can result in injury. To reduce the potential for injury, comply with these safety instructions and always pay attention to the safety alert ⚠ symbol, which means CAUTION, WARNING, or DANGER—“personal safety instruction.” Failure to comply with the instruction may result in personal injury or death.**

# Safe Operating Practices

The following instructions are from ANSI standard B71.4—1999.

## Training

- Read the Operator’s Manual and other training material. If the operator(s) or mechanic(s) can not read English it is the owner’s responsibility to explain this material to them.
- Become familiar with the safe operation of the equipment, operator controls, and safety signs.
- All operators and mechanics should be trained. The owner is responsible for training the users.
- Never let children or untrained people operate or service the equipment. Local regulations may restrict the age of the operator.

- The owner/user can prevent and is responsible for accidents or injuries occurring to himself or herself, other people or property.

## Preparation

- Evaluate the terrain to determine what accessories and attachments are needed to properly and safely perform the job. Only use accessories and attachments approved by the manufacturer.
- Wear appropriate clothing including hard hat, safety glasses and ear protection. Long hair, loose clothing or jewelry may get tangled in moving parts.
- Inspect the area where the equipment is to be used and remove all objects such as rocks, toys and wire which can be thrown by the machine.
- Use extra care when handling gasoline and other fuels. They are flammable and vapors are explosive.
  - Use only an approved container
  - Never remove gas cap or add fuel with engine running. Allow engine to cool before refueling. Do not smoke.
  - Never refuel or drain the machine indoors.
- Check that operator's presence controls, safety switches and shields are attached and functioning properly. Do not operate unless they are functioning properly.

## Operation

- Never run an engine in an enclosed area.
- Only operate in good light, keeping away from holes and hidden hazards.
- Be sure all drives are in neutral and parking brake is engaged before starting engine. Only start engine from the operator's position. Use seat belts if provided.
- Slow down and use extra care on hillsides. Be sure to travel in the recommended direction on hillsides. Tuff conditions can affect the machine's stability. Use caution while operating near drop-offs.
- Slow down and use caution when making turns and when changing directions on slopes.
- Never raise deck with the blades running.
- Never operate with the PTO shield, or other guards not securely in place. Be sure all interlocks are attached, adjusted properly, and functioning property.
- Never operate with the discharge deflector raised, removed or altered, unless using a grass catcher.

- Do not change the engine governor setting or overspeed the engine.
- Stop on level ground, lower implements, disengage drives, engage parking brake (if provided), shut off engine before leaving the operator's position for any reason including emptying the catchers or unclogging the chute.
- Stop equipment and inspect blades after striking objects or if an abnormal vibration occurs. Make necessary repairs before resuming operations.
- Keep hands and feet away from the cutting units.
- Look behind and down before backing up to be sure of a clear path.
- Never carry passengers and keep pets and bystanders away.
- Slow down and use caution when making turns and crossing roads and sidewalks. Stop blades if not mowing.
- Be aware of the mower discharge direction and do not point it at anyone.
- Do not operate the mower under the influence of alcohol or drugs
- Use care when loading or unloading the machine into a trailer or truck
- Use care when approaching blind corners, shrubs, trees, or other objects that may obscure vision.

## Maintenance and storage

- Disengage drives, lower implement, set parking brake, stop engine and remove key or disconnect spark plug wire. Wait for all movement to stop before adjusting, cleaning or repairing.
- Clean grass and debris from cutting units, drives, mufflers, and engine to help prevent fires. Clean up oil or fuel spillage.
- Let engine cool before storing and do not store near flame.
- Shut off fuel while storing or transporting. Do not store fuel near flames or drain indoors.
- Park machine on level ground. Never allow untrained personnel to service machine.
- Use jack stands to support components when required.
- Carefully release pressure from components with stored energy.

- Disconnect battery or remove spark plug wire before making any repairs. Disconnect the negative terminal first and the positive last. Reconnect positive first and negative last.
- Use care when checking blades. Wrap the blade(s) or wear gloves, and use caution when servicing them. Only replace blades. Never straighten or weld them.
- Keep hands and feet away from moving parts. If possible, do not make adjustments with the engine running.
- Charge batteries in an open well ventilated area, away from spark and flames. Unplug charger before connecting or disconnecting from battery. Wear protective clothing and use insulated tools.
- Keep all parts in good working condition and all hardware tightened. Replace all worn or damaged decals.

## Toro Mower Safety

The following list contains safety information specific to Toro products or other safety information that you must know that is not included in the ANSI standards.

This product is capable of amputating hands and feet and throwing objects. Always follow all safety instructions to avoid serious injury or death.

This product is designed for cutting and recycling grass or, when equipped with a grass bagger, for catching cut grass. Any use for purposes other than these could prove dangerous to user and bystanders.

### General Operation

- Allow only responsible adults who are familiar with the instructions to operate the machine.
- Be sure the area is clear of other people before mowing. Stop the machine if anyone enters the area.
- Do not mow in reverse unless absolutely necessary. Always look down and behind before and while backing.
- Be aware of the mower discharge direction and do not point it at anyone. Do not operate the mower without either the entire grass catcher or the guard in place.
- Slow down before turning. Sharp turns on any terrain may cause loss of control.
- Turn off blades when not mowing.
- Keep hands, feet, hair and loose clothing away from attachment discharge area, underside of mower and any moving parts while engine is running.

- Stop the engine before removing the grass catcher or unclogging the chute.
- Mow only in daylight or good artificial light.
- Watch for traffic when operating near or crossing roadways.
- Do not touch equipment or attachment parts which may be hot from operation. Allow to cool before attempting to maintain, adjust or service.
- Before operating a machine with ROPS (roll over protection) be certain the seat belts are attached to prevent the seat from pivoting forward.
- Use only Toro-approved attachments. Warranty may be voided if used with unapproved attachments.

### Slope Operation

Slopes and ramps are a major factor related to loss-of-control and tip-over accidents, which can result in severe injury or death. All slopes and ramps require extra caution. If you cannot back up the slope or if you feel uneasy on it, do not mow it.

#### DO

- If a steep slope must be ascended, back up the hill, and drive forward down the hill, keeping the machine in gear.
- Remove obstacles such as rocks, tree limbs, etc. from the mowing area. Watch for holes, ruts or bumps, as uneven terrain could overturn the machine. Tall grass can hide obstacles.
- Use slow speed so that you will not have to stop while on the slope.
- Follow the manufacturer's recommendations for wheel weights or counterweights to improve stability.
- Use extra care with grass catchers or other attachments. These can change the stability of the machine.
- Keep all movement on slopes slow and gradual. Do not make sudden changes in speed or direction.
  - Avoid starting or stopping on a slope. If tires lose traction, disengage the blades and proceed slowly straight down the slope.
- When operating machine on slopes, banks or near drop offs, always have ROPS (roll over protection) installed.
- When operating a machine with ROPS (roll over protection) always use seat belt.
- Be certain that the seat belt can be released quickly if the machine is driven or rolls into ponds or water.

- Check carefully for overhead clearances (i.e. branches, doorways, electrical wires) before driving under any objects and do not contact them.

## **DO NOT**

- Do not mow slopes exceeding 15 degrees.
- Avoid turning on slopes. If you must turn, turn slowly and gradually downhill, if possible.
- Do not mow near drop-offs, ditches, or embankments. The machine could suddenly turn over if a wheel goes over the edge of a cliff or ditch, or if an edge caves in.
- Do not mow on wet grass. Reduced traction could cause sliding.
- Do not use a grass catcher on steep slopes. Heavy grass bags could cause loss of control or overturn the machine.

## **Service**

- Never store the machine or fuel container inside where there is an open flame, such as near a water heater or furnace.
- Keep nuts and bolts tight, especially the blade attachment bolts. Keep equipment in good condition.
- Never tamper with safety devices. Check safety systems for proper operation before each use.
- Use only genuine replacement parts to ensure that original standards are maintained.
- Check brake operation frequently. Adjust and service as required.
- Battery acid is poisonous and can cause burns. Avoid contact with skin, eyes and clothing. Protect your face, eyes and clothing when working with a battery.
- Battery gases can explode. Keep cigarettes, sparks and flames away from battery.
- Hydraulic fluid escaping under pressure can penetrate the skin and cause injury. Use cardboard or paper to find hydraulic leaks. Never use your hands.

PROTOTYPE

# Slope Chart

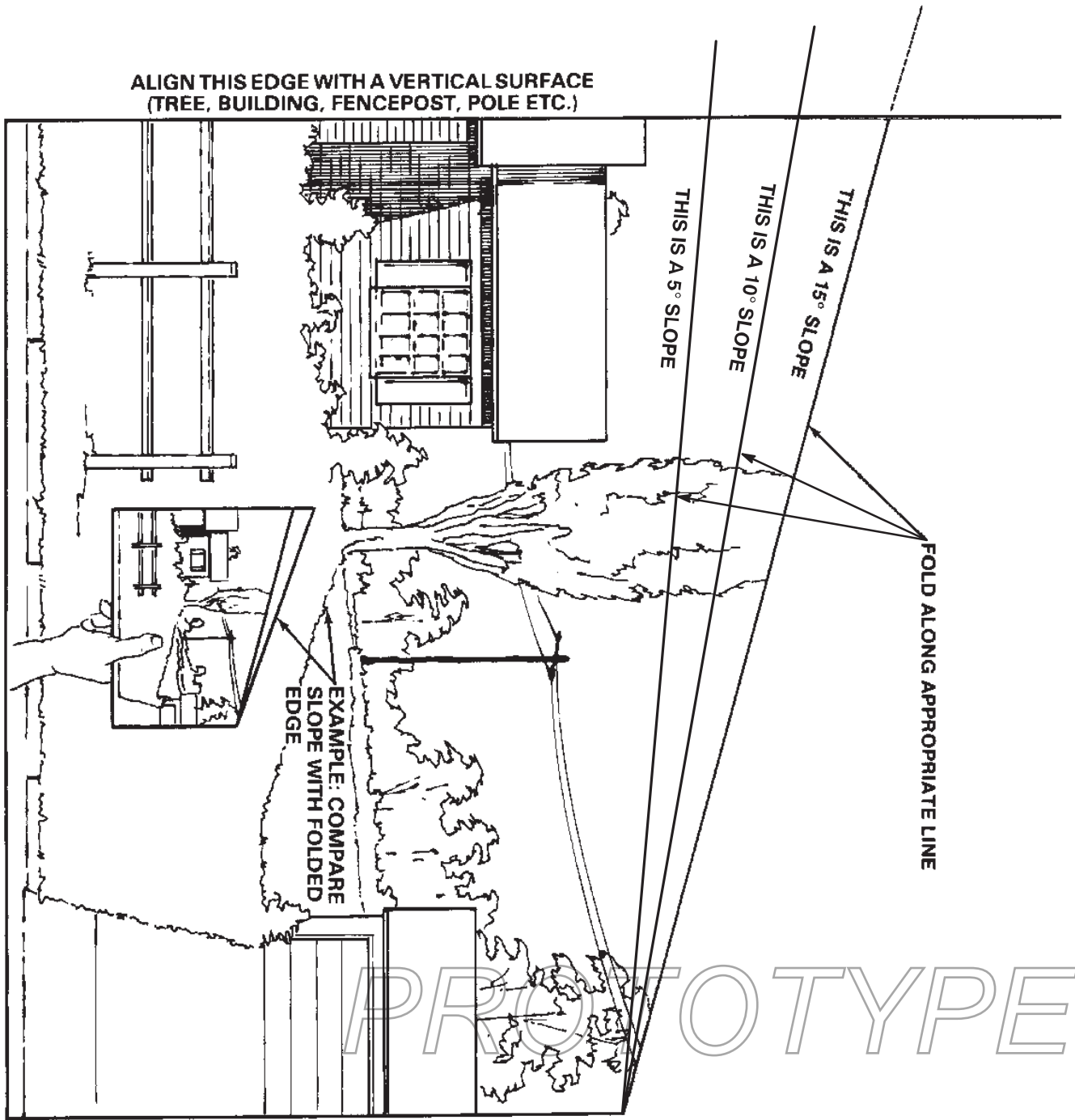

*PROTOTYPE*

# Safety and Instruction Decals



Safety decals and instructions are easily visible to the operator and are located near any area of potential danger. Replace any decal that is damaged or lost.

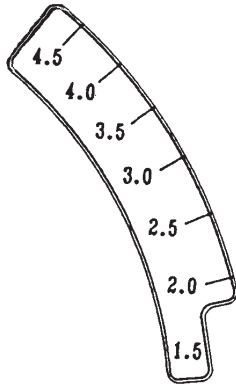

1-653140

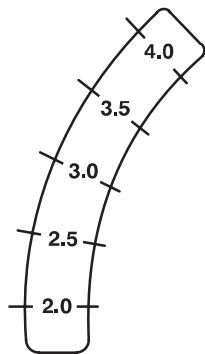

1-653147



1-523552

### CHECK SERVICE REFERENCE AID

- GREASE LUBE POINTS AT INTERVALS SHOWN.
- ▲ CHECK HYDRAULIC FLUID AT INTERVAL SHOWN. (USE ONLY MOBIL 1 15W-50 SYNTHETIC MOTOR OIL.)
- ② SEE ENGINE OPERATOR'S MANUAL FOR SERVICING ENGINE.
- ③ CHECK TIRE PRESSURE - 13 PSI AT INTERVAL SHOWN. SEE OPERATOR'S MANUAL FOR ADDITIONAL DETAILS.

99-3924

99-3924

MERCURY SWITCH 633782  
SEE OPERATOR'S MANUAL  
FOR DISPOSAL INSTRUCTIONS

E 643401

1-643401

### ▲ WARNING

- PARKING BRAKE MAY NOT HOLD MACHINE IF PARKED ON SLOPE.
- UNATTENDED UNIT MAY ROLL AWAY & CAUSE PERSONAL INJURY OR PROPERTY DAMAGE.
- DO NOT PARK ON SLOPES UNLESS WHEELS ARE CHOCKED OR BLOCKED.

E 633818

1-633818



43-8480

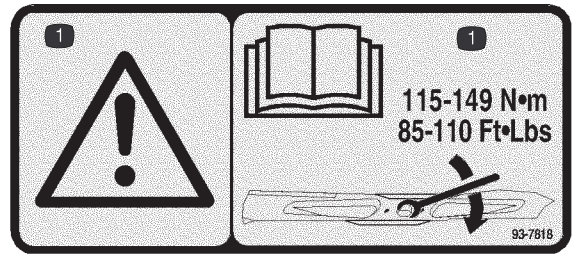

93-7818

1. Warning—read the *Operator's Manual* for instructions on torquing the blade bolt/nut to 115–149 N·m (85–110 ft·lb).



66-1340

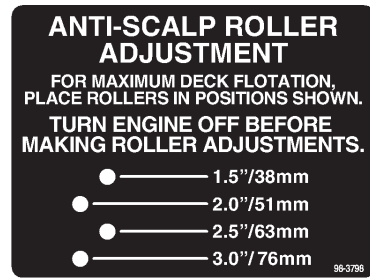

98-3798



67-5360



98-4387

1. Warning—wear hearing protection.



93-1122



98-5954

PROTOTYPE

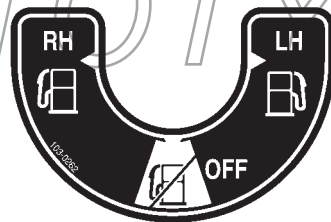

103-0262

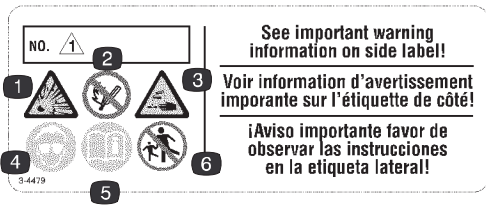

104-4163

- |  |  |
|--|--|
| 1. Explosion hazard                    | 4. Wear eye protection                               |
| 2. No fire, open flames, or smoking.   | 5. Read the <i>Operator's Manual</i> .               |
| 3. Caustic liquid/chemical burn hazard | 6. Keep bystanders a safe distance from the battery. |



104-8569

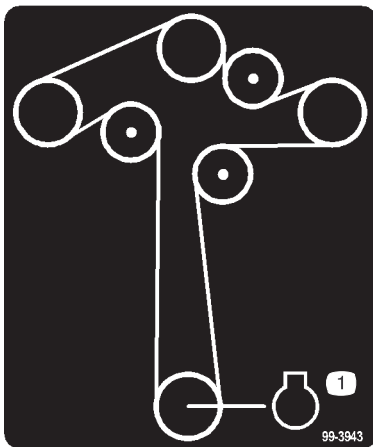

99-3943

1. Engine



65-2690



103-2644

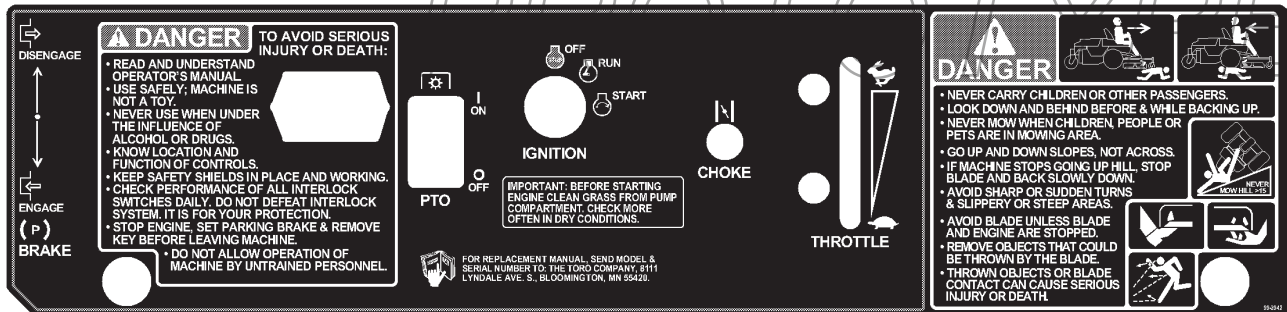

99-3942



**CAUTION**  
 Mercury in tilt switch is poisonous and can cause severe illness.  
 \* Never attempt to open or repair switch.  
 \* Avoid contact with mercury. See operator's manual for disposal rules.

**WARNING**  
 Battery contains sulfuric acid. Avoid contact and always shield eyes, face, skin and clothing from battery. Cigarettes, flames

or sparks could cause battery to explode. Do not charge or use booster cables or adjust post connections without proper training. In event of an accident flush with water and call a physician immediately. Keep out of reach of children.

**DRIVE WHEEL RELEASE**  
  
 Use 5/8 wrench  
 One turn counterclockwise to release  
 Do not over-tighten



103-1997

103-1997

**MAINTENANCE FREE • SANS ENTRETIEN • LIBRE DE MANTENIMIENTO**

NIVEAU MAXIMUM      MAXIMUM FILL      CAPACIDAD MAXIMA  
 NIVEAU MINIMUM      MINIMUM FILL      CAPACIDAD MINIMA

1  
2  
3-1808

**⚠ DANGER/POISON ¡PELIGRO/VENENO!**

<p><b>SHIELD EYES.</b> EXPLOSIVE GASES CAN CAUSE BLINDNESS OR INJURY.</p> <p><b>PROTÉGER LES YEUX. GAZ EXPLOSIFS</b> PEUVENT RENDRE AVEUGLE OU PROVOQUER DES LESIONS.</p> <p><b>PROTEJA LOS OJOS. GASES EXPLOSIVOS</b> PUEDEN CAUSAR CEGUERA O DAÑO.</p>	<p><b>NO SPARKS • FLAMES • SMOKING</b></p> <p><b>ÉLOIGNER</b> • ÉTINCELLES • FLAMMES • CIGARETTES</p> <p><b>NO</b> • CHISPAS • FLAMAS • FUMAR</p>	<p><b>SULFURIC ACID CAN CAUSE BLINDNESS OR SEVERE BURNS.</b></p> <p><b>ACIDE SULFURIQUE</b> PEUT RENDRE AVEUGLE OU PROVOQUER DES BRULURES GRAVES.</p> <p><b>ACIDO SULFURICO</b> PUEDA CAUSAR CEGUERA O QUEMADURAS SEVERAS.</p>	<p><b>FLUSH EYES IMMEDIATELY WITH WATER. GET MEDICAL HELP FAST.</b></p> <p><b>RINCER IMMEDIATEMENT LES YEUX A GRANDE EAU. CONTACTER RAPIDEMENT UN MEMBRE DE LA PROFESSION MEDICALE.</b></p> <p><b>LAVE LOS OJOS DE INMEDIATO. CONSIGA AYUDA MEDICA RAPIDO.</b></p>
--	---	--	--

**KEEP OUT OF THE REACH OF CHILDREN. DO NOT TIP. DO NOT OPEN BATTERY!**  
**MAINTENIR HORS DE LA PORTÉE DES ENFANTS. NE RENVERSEZ PAS. N'OUVREZ PAS LA BATTERIE!**  
**MANTENGASE FUERA DEL ALCANCE DE LOS NIÑOS. NO INCLINE. NO ABRA LA BATERIA!**

**HOW TO ACTIVATE DRY CHARGED BATTERIES**

1. Use only battery electrolyte (1.265 Sp.Gr.) to fill battery initially.
2. Do not overfill. Let stand for 15 minutes.
3. Charge battery at 4-5 amps until specific gravity is 1.250 or higher and temperature is at least 60°F. - all cells gassing freely.
4. After battery has been activated, add only water to replace normal loss.

Dist. by:/por:/par: The Toro Company, Bloomington, MN 55420      MADE IN U.S.A. • FABRIQUE AUX E.U.A. • HECHO EN E.U.A.

104-4164

- |                                   |  |   |  |
|-----------------------------------|--|---|--|
| 1. Contains lead; do not discard. | 3. Wear eye protection; explosive gases can cause blindness and other injuries | 5. Sulfuric acid can cause blindness or severe burns.           | 7. Maximum fill line                       |
| 2. Recycle                        | 4. No sparks, flame, or smoking  | 6. Flush eyes immediately with water and get medical help fast. | 8. Minimum fill line                       |
|                                   |  |   | 9. Instructions for activating the battery |

PROTOTYPE

# Gasoline and Oil

## Recommended Gasoline

Use UNLEADED Regular Gasoline suitable for automotive use (85 pump octane minimum). Leaded regular gasoline may be used if unleaded regular is not available.

**Important** Never use methanol, gasoline containing methanol, or gasohol containing more than 10% ethanol because the fuel system could be damaged. Do not mix oil with gasoline.



### Danger



In certain conditions, gasoline is extremely flammable and highly explosive. A fire or explosion from gasoline can burn you and others and can damage property.

- Fill the fuel tank outdoors, in an open area, when the engine is cold. Wipe up any gasoline that spills.
- Never fill the fuel tank inside an enclosed trailer.
- Do not fill the fuel tank completely full. Add gasoline to the fuel tank until the level is 1/4 to 1/2 inch (6 to 13 mm) below the bottom of the filler neck. This empty space in the tank allows gasoline to expand.
- Never smoke when handling gasoline, and stay away from an open flame or where gasoline fumes may be ignited by a spark.
- Store gasoline in an approved container and keep it out of the reach of children. Never buy more than a 30-day supply of gasoline.
- Always place gasoline containers on the ground away from your vehicle before filling.
- Do not fill gasoline containers inside a vehicle or on a truck or trailer bed because interior carpets or plastic truck bed liners may insulate the container and slow the loss of any static charge.
- When practical, remove gas-powered equipment from the truck or trailer and refuel the equipment with its wheels on the ground.
- If this is not possible, then refuel such equipment on a truck or trailer from a portable container, rather than from a gasoline dispenser nozzle.
- If a gasoline dispenser nozzle must be used, keep the nozzle in contact with the rim of the fuel tank or container opening at all times until fueling is complete.
- Do not operate without entire exhaust system in place and in proper working condition.



### Warning



Gasoline is harmful or fatal if swallowed. Long-term exposure to vapors can cause serious injury and illness.

- Avoid prolonged breathing of vapors.
- Keep face away from nozzle and gas tank or conditioner opening.
- Keep gas away from eyes and skin.

## Using Stabilizer/Conditioner

Use a fuel stabilizer/conditioner in the machine to provide the following benefits:

- Keeps gasoline fresh during storage of 90 days or less. For longer storage it is recommended that the fuel tank be drained.
- Cleans the engine while it runs
- Eliminates gum-like varnish buildup in the fuel system, which causes hard starting

**Important** Do not use fuel additives containing methanol or ethanol.

Add the correct amount of gas stabilizer/conditioner to the gas.

**Note:** A fuel stabilizer/conditioner is most effective when mixed with fresh gasoline. To minimize the chance of varnish deposits in the fuel system, use fuel stabilizer at all times.

## Filling the Fuel Tank

1. Shut the engine off and set the parking brake.
2. Clean around each fuel tank cap and remove the cap. Add unleaded regular gasoline to both fuel tanks, until the level is 1/4 to 1/2 inch (6 mm to 13 mm) below the bottom of the filler neck. This space in the tank allows gasoline to expand. Do not fill the fuel tanks completely full.
3. Install fuel tank caps securely. Wipe up any gasoline that may have spilled.

## Check Engine Oil Level

Before you start the engine and use the machine, check the oil level in the engine crankcase; refer to Checking the Engine Oil Level, page 30.

# Setup

## Loose Parts

**Note:** Use the chart below to verify all parts have been shipped.

Description	Qty.	Use
Rear Wheels	2	Installing the drive wheels
Retaining rod	1	Installing the seat retaining rod
Bolt, 5/16 x 1 inch	1	
Locknut, 5/16 inch	1	
Control lever–right	1	Installing the motion control levers
Control lever–left	1	
Bolt, 3/8 x 1 inch	4	
Spring washer, 3/8 inch	4	
Key	2	Read before operating machine
Operator's Manual	1	
Engine Operator's Manual	1	
Parts Catalog	1	
Registration card	1	Fill out and return to Toro

## Installing the Drive Wheels

1. Uncrate mower.
1. Remove wheel bolts or nuts from rear wheel hubs.
2. Align holes. Mount drive wheels with the valve stem to the outside of the traction unit.
3. Secure using wheel bolts or nuts provided. Torque to 95 ft-lb (128 N•M).

**Important** Make sure that wheel nuts are torqued to 95 ft-lb (128 N•M).

## Tire Pressure

Check the air pressure in the front and rear tires (Fig. 2).

Pressure: 13 psi (90 kPa)

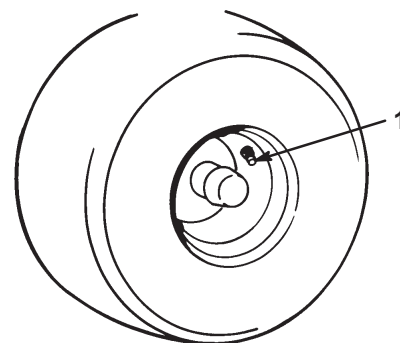

m-1872

**Figure 2**  
1. Valve stem

PROTOTYPE

## Installing the Seat Retaining Rod

1. Tilt seat up. Remove the locknut (5/16 inch) from bolt attaching seat retaining rod to seat frame (Fig. 3).
2. Remove retaining rod from seat and insert the **L** shaped end of the rod into the hole directly above the left-side hydraulic pump (Fig. 3).

- Place the seat retaining rod to the outside of the mounting tab of the seat frame and secure with a bolt (5/16 x 1 inch) bolt and locknut 5/16 inch (Fig. 3).
- Tighten until snug, then loosen so the rod pivots freely.

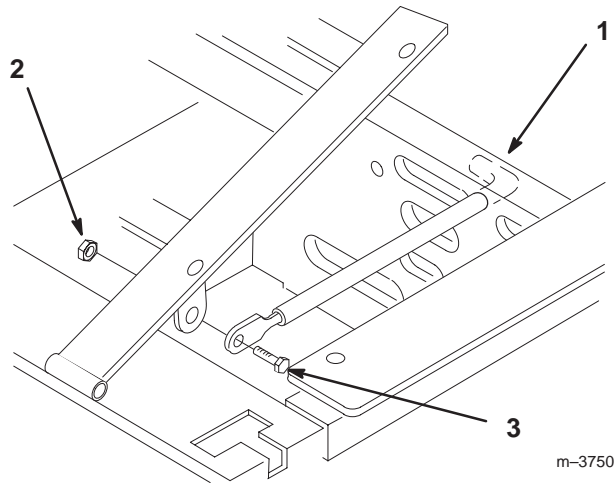

**Figure 3**

- L end of retaining rod
- Locknut, 5/16 inch
- Bolt, 5/16 x 1 inch

## Installing the Motion Control Levers

There are two positions to install the control levers, high and low. Install levers in the top and middle holes for the high position. Install levers in the middle and bottom holes for the low position.

- Remove the 4 bolts (3/8 x 1 inch) and 4 spring washers (3/8 inch) which attach the motion control levers to the control arm shafts for shipping (Fig. 4).
- Place the levers (with the mounting plate toward the rear) on the outside of the control arm shaft and secure with 4 bolts (3/8 x 1 inch) and 4 spring washers (3/8 in.) (Fig. 4).
- Position the levers so the bolts are in the center of the slots on the lever mounting plate and tighten until snug.
- Align the front/rear position of the levers, with each other, in the neutral position. Loosen hardware and adjustment by sliding/tilting the lever(s) forward or backward until properly aligned (Fig. 4).

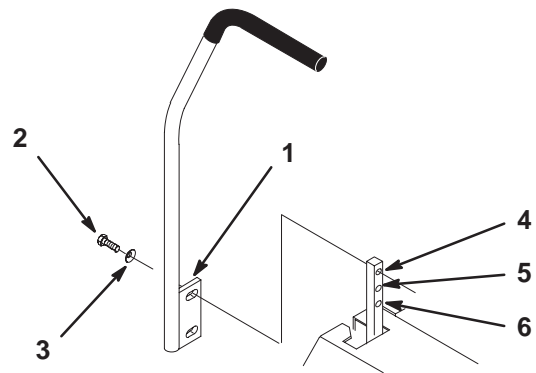

m-5596

**Figure 4**

- Mounting plate
- Bolt, 3/8 x 1 inch
- Spring washer, 3/8 inch
- Top hole
- Middle hole
- Bottom hole

- If the ends of the levers hit against each other, while in the drive position (Fig. 5) (levers rotated in as far as possible) make adjustments by moving the levers outward to the neutral lock position and carefully bend them outward. Move them back to the drive position and check for clearance. Repeat if necessary.

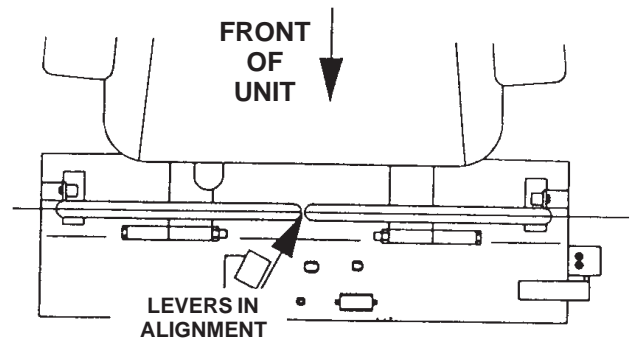

**Figure 5**

## Activating the Battery

Bulk electrolyte with 1.265 specific gravity must be purchased from a local battery supply outlet.



## Danger



Battery electrolyte contains sulfuric acid which is a deadly poison and causes severe burns.

- Do not drink electrolyte and avoid contact with skin, eyes or clothing. Wear safety glasses to shield your eyes and rubber gloves to protect your hands.
- Fill the battery where clean water is always available for flushing the skin.
- Follow all instructions and comply with all safety messages on the electrolyte container.

1. Remove the battery from the machine. Refer to Removing the Battery on page 42.

2. Clean the top of the battery with a paper towel.

**Note:** Never fill the battery with electrolyte while the battery is installed in the machine. Electrolyte could be spilled on other parts and cause corrosion.

3. Remove the vent caps from the battery (Fig. 56).

4. Slowly pour electrolyte into each battery cell until the level is up to the **upper** line (Fig. 56) on the battery case.

**Important** Do not overfill the battery because electrolyte (sulfuric acid) can cause severe corrosion and damage to the chassis.

5. Wait five to ten minutes after filling the battery cells. Add electrolyte, if necessary, until the electrolyte level is up to the **upper** line (Fig. 56) on the battery case.

6. Reinstall battery filler caps.

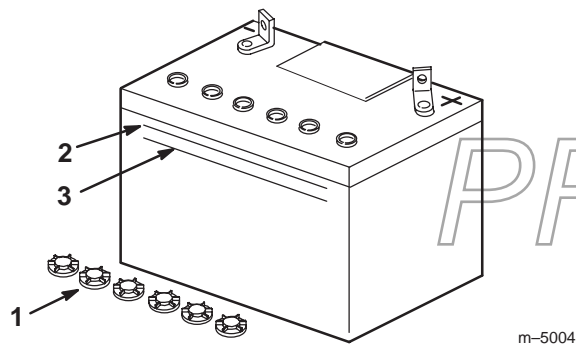

Figure 6

1. Filler caps
2. **Upper** line

3. **Lower** line



## Warning



Charging battery produces gasses that can explode and cause serious injury.

- Keep cigarettes, sparks and flames away from battery.
- Make sure the ignition switch is off.
- Ventilate when charging or using battery in an enclosed space.

7. Charge the battery. Refer to Charging the Battery on page 43.

8. Install the battery into the machine. Refer to Installing the Battery on page 42.

**Note:** Do not run the machine with the battery disconnected, electrical damage may occur.

## Checking the Hydraulic Fluid

Check the hydraulic fluid level before the engine is first started.

Refer to Checking the Hydraulic Fluid on page 35.

## Greasing the Bearings

**Make sure cutting unit spindles are full of grease before engine is first started.**

Grease with No. 2 general purpose lithium base or molybdenum base grease.

1. Grease the fittings on the three spindle bearings. Grease until it comes out lower seals (Fig. 7).

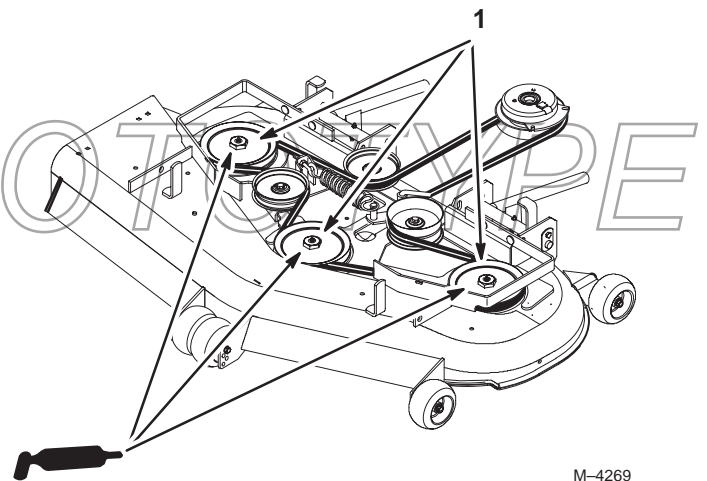

Figure 7

1. Spindles

## Check the Level of Mower

Check the level of the deck before machine is first put into use.

Refer to Adjusting the Mower Level section on page 43.

## Check Side Discharge Chute

Remove plastic tie holding side discharge chute up and lower into place.

## Check Engine Oil Level

Before you start the engine and use the machine, check the oil level in the engine crankcase; refer to Checking the Engine Oil Level, page 30.

# Operation

## Think Safety First

Please read all safety instructions and symbols in the safety section. Knowing this information could help you, your family, pets or bystanders avoid injury.

The use of protective equipment for eyes, ears, feet, and head is recommended.

⚠
Caution
⚠

**This machine produces sound levels in excess of 85 dBA at the operator's ear and can cause hearing loss through extended periods of exposure.**

**Wear hearing protection when operating this machine.**

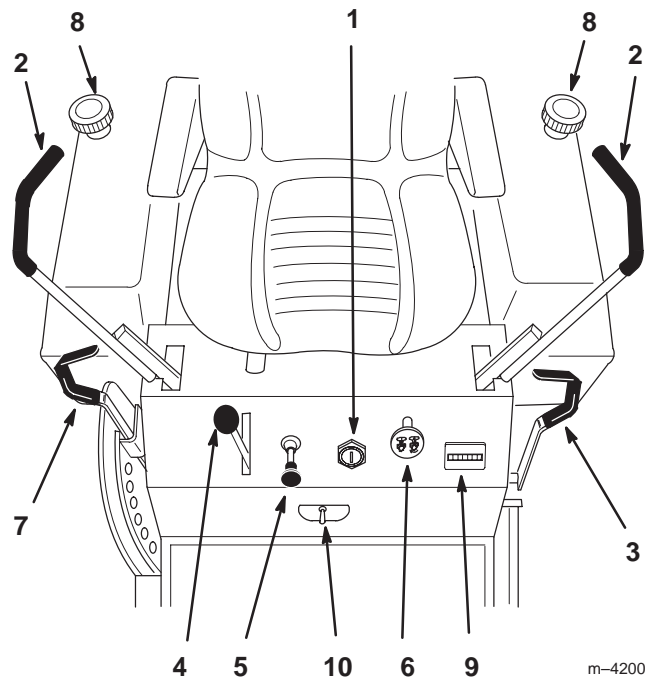

**Figure 8**

1. Warning—wear hearing protection.

## Controls

Become familiar with all the controls (Fig. 9) before you start the engine and operate the machine.

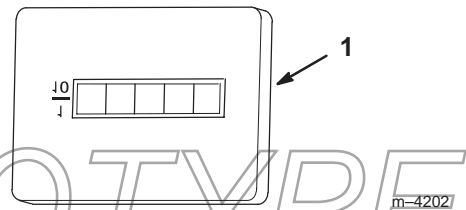

**Figure 9**

- |                         |                         |
|-------------------------|-------------------------|
| 1. Ignition switch      | 6. Power take off (PTO) |
| 2. Motion control lever | 7. Height-of-Cut lever  |
| 3. Parking brake lever  | 8. Fuel cap             |
| 4. Throttle             | 9. Hourmeter            |
| 5. Choke                | 10. Fuel shut-off valve |

## Using the Hour Meter

The hour meter records the number of hours the engine has operated. It operates when the engine is running. Use these times for scheduling regular maintenance.



**Figure 10**

1. Hour meter

## Switching the Fuel Tanks

The unit has two fuel tanks, one located on the left side and one on the right side. Each tank connects to the fuel shut off valve in the control panel. From there a common fuel line leads to the engine (Fig. 11).

To use the right side fuel tank rotate the fuel shut off valve 1/4 turn to the right from the off location. This uses fuel from the right side tank only. When the right fuel tank is empty, move the fuel shut off valve 1/4 turn to the left from the off position.

Close fuel shut off valve, on front panel before transporting or storing machine.

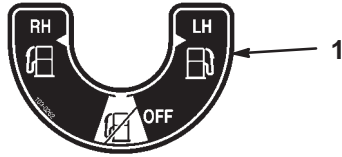

**Figure 11**

1. Shut-off valve

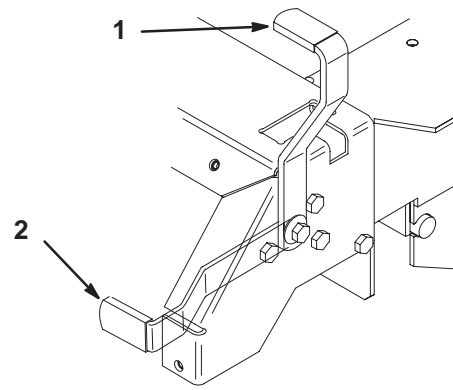

**Figure 12**

1. Parking brake—ON
2. Parking brake—OFF

m-4121

## Operating the Parking Brake

Always set the parking brake when you stop the machine or leave it unattended.

**Important** Do not park on slopes unless wheels are chocked or blocked.

### Setting the Parking Brake

1. Move the motion control levers (Fig. 9) out to the neutral lock position.
2. Pull back and up on the parking brake lever to set the parking brake (Fig. 12). The parking brake lever should stay firmly in the engaged position.

### Releasing the Parking Brake

1. Push forward and down on the parking brake lever to release the parking brake (Fig. 12). The parking brake is disengaged and the lever rests against the brake stop.

## Using the Blowout Baffles

Blowout baffles are used when in side discharge mode only.

**Important** Do not use blowout baffles while in recycling mode.

1. To install or remove blowout baffles, install or remove bolts as shown in Figure 13.

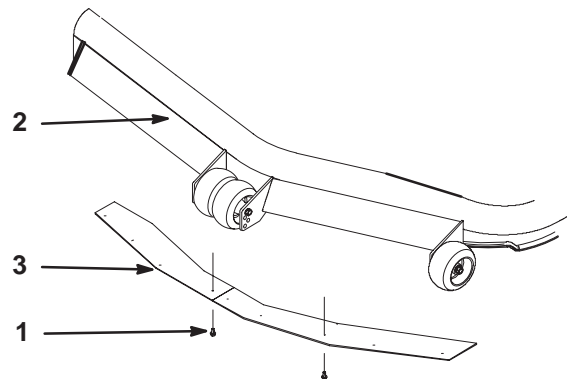

**Figure 13**

1. Bolts
2. Front of deck
3. Baffles

M-4661

PROTOTYPE

## Starting and Stopping the Engine

### Starting the Engine

1. Sit down on the seat and move the motion controls to neutral locked position.
2. Set the parking brake; refer to Setting the Parking Brake, page 18.

3. Move the PTO (power take off) to the *off* position (Fig. 14).
4. Move the choke control to *on* position before starting a cold engine (Fig. 15).

**Note:** A warm or hot engine may require choking. After engine starts, move choke control to the *off* position.

5. Move the throttle control to the fast position before starting a cold engine (Fig. 16).
6. Turn ignition key to start to energize starter. When engine starts, release key (Fig. 17).

**Important** Do not engage starter for more than 10 seconds at a time. If engine fails to start allow 30 second cool-down period between attempts. Failure to follow these instructions can burn out starter motor.

7. After the engine starts, move the choke to *off* (Fig. 15). If the engine stalls or hesitates, move the choke back to *on* for a few seconds. Then move the throttle lever to desired setting. Repeat this as required.

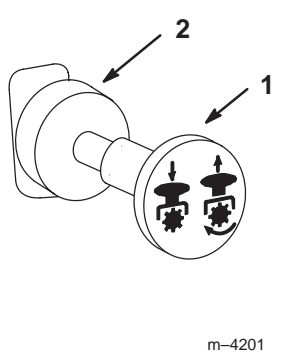

**Figure 14**

1. PTO—On
2. PTO—Off

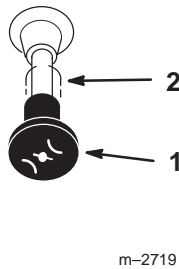

**Figure 15**

1. Choke—On
2. Choke—Off

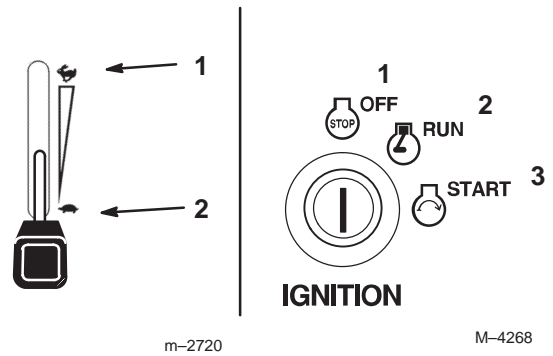

**Figure 16**

1. Fast
2. Slow

**Figure 17**

1. Off
2. Run
3. Start

## Stopping the Engine

1. Push the PTO to off (Fig. 16).
2. Move the throttle lever midway between the slow and fast positions (Fig. 16).
3. Let the engine idle for 60 seconds (Fig. 17).
4. Turn the ignition key to off (Fig. 17).
5. Pull wire off spark plug(s) to prevent possibility of someone accidentally starting the machine before transporting or storing machine.
6. Close fuel shut off valve, on front panel before transporting or storing machine.

**Important** Make sure that the fuel shut off valve is closed before transporting or storing the machine, as fuel leakage may occur. Set the parking brake before transporting. Make sure to remove the key as the fuel pump may run and cause the battery to lose charge.

**Caution**

**Children or bystanders may be injured if they move or attempt to operate the tractor while it is unattended.**

**Always remove the ignition key and set the parking brake when leaving the machine unattended, even if just for a few minutes.**

# Operating the Power Take Off (PTO)

The power take off (PTO) switch engages and disengages power to the electric clutch.

## Engaging the PTO

1. While seated in the seat, release pressure on the traction control levers and place in neutral.
2. Place throttle to the fast position.
3. Pull out on the power take off (PTO) switch to engage the PTO (Fig. 18).

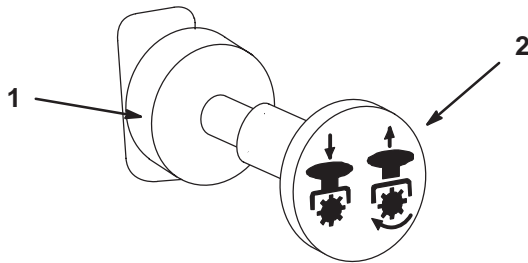

m-4201

Figure 18

1. PTO—Off                      2. PTO—On

## Disengaging the PTO

1. To disengage push the PTO switch to the *off* position (Fig. 18).

## The Safety Interlock System

**Caution**

If safety interlock switches are disconnected or damaged the machine could operate unexpectedly causing personal injury.

- Do not tamper with the interlock switches.
- Check the operation of the interlock switches daily and replace any damaged switches before operating the machine.

## Understanding the Safety Interlock System

The safety interlock system is designed to prevent the engine from starting unless:

- You are sitting on the seat.
- The parking brake is engaged.
- The power take off (PTO) is disengaged.
- The motion control levers are in neutral locked position.

The safety interlock system also is designed to stop the engine when the traction controls are moved from the locked position with the parking brake **engaged** or if you rise from the seat when the PTO is **on** or engaged.

## Testing the Safety Interlock System

Test the safety interlock system before you use the machine each time. If the safety system does not operate as described below, have an Authorized Service Dealer repair the safety system immediately.

1. Sitting on the seat, engage the parking brake and move the PTO to on. Try starting the engine; the engine should not crank.
2. Sitting on the seat, engage the parking brake and move the PTO to on. Move either motion control lever (out of neutral locked position). Try starting the engine; the engine should not crank. Repeat for other control lever.
3. Sitting on the seat, engage the parking brake, move the PTO switch to off and move the motion control levers to neutral lock position. Now start the engine. While the engine is running, release the parking brake, engage the PTO and rise slightly from the seat; the engine should stop.
4. Sitting on the seat, engage the parking brake, move the PTO switch to off, and move the motion control levers to neutral lock position. Now start the engine. While the engine is running, center either motion control and move (forward or reverse); the engine should stop. Repeat for other motion control.
5. Sitting on the seat, disengage the parking brake, move the PTO switch to off and move the motion control levers to neutral lock position. Try starting the engine; the engine should not crank.

## Driving Forward or Backward

The throttle control regulates the engine speed as measured in rpm (revolutions per minute). Place the throttle control in the *fast* position for best performance. Always operate in the full throttle position

**Caution**

**Machine can spin very rapidly. Operator may lose control of machine and cause personal injury or damage to machine.**

- Use caution when making turns.
- Slow the machine down before making sharp turns.

## Driving Forward

1. Release the parking brake; refer to Releasing the Parking Brake, page 18.
2. Move levers to the center, un-locked position.
3. To go forward, slowly push the motion control levers forward (Fig. 19).

**Note:** Engine will kill if traction control levers are moved with parking brake engaged.

To go straight, apply equal pressure to both motion control levers (Fig. 19).

To turn, release pressure on the motion control lever toward the direction you want to turn (Fig. 19).

The farther you move the traction control levers in either direction, the faster the machine will move in that direction.

To stop pull the motion control levers to neutral.

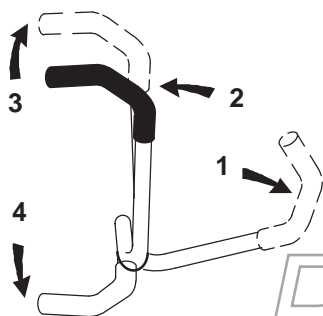

**Figure 19**

- |   |                           |
|---|---------------------------|
| 1. Motion control lever—neutral lock position | 2. Center unlock position |
|   | 3. Forward                |
|   | 4. Backward               |

## Driving Backward

1. Move levers to the center, unlocked position.
2. To go backward, slowly pull the motion control levers rearward (Fig. 19).

To go straight, apply equal pressure to both motion control levers (Fig. 19).

To turn, release pressure on the motion control lever toward the direction you want to turn (Fig. 19).

To stop push the motion control levers to neutral.

## Stopping the Machine

To stop the machine, move the traction control levers to neutral and move to locked position, disengage the power take off (PTO), and turn the ignition key to off. Also set the parking brake when you leave the machine; refer to Setting the Parking Brake, page 18. Remember to remove the key from the ignition switch.

**Caution**

**Children or bystanders may be injured if they move or attempt to operate the tractor while it is unattended.**

**Always remove the ignition key and set the parking brake when leaving the machine unattended, even if just for a few minutes.**

## Adjusting the Height-of-Cut

The height-of-cut is adjusted from 1-1/2 to 4-1/2 inch (38 to 114 mm) in 1/4 inch (6 mm) increments by relocating clevis pin in different hole locations.

1. Raise the height-of-cut lever to the transport position (also the 4-1/2-inch (114 mm) cutting height position) (Fig. 20).
2. To adjust, remove hairpin cotter and clevis pin from height-of-cut bracket (Fig. 20).
3. Select hole in height-of-cut bracket corresponding to the height-of-cut desired, and insert clevis pin (Fig. 20).
4. Secure clevis pin with hairpin cotter (Fig. 20).

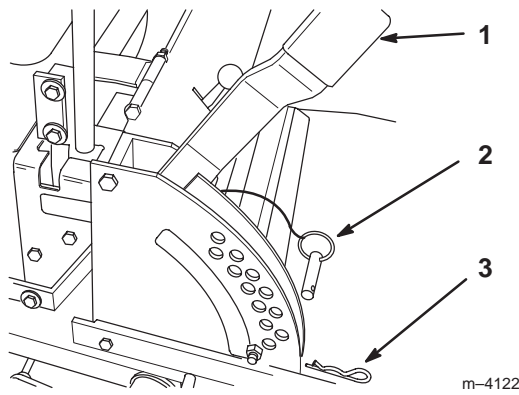

**Figure 20**

- 1. Height-of-cut lever
- 2. Clevis pin
- 3. Hairpin cotter

5. Lower height-of-cut lever onto clevis pin.

## Adjusting Anti-Scalp Rollers

Whenever you change the height-of-cut it is recommended to adjust the height of the anti-scalp rollers.

### Adjusting the Outside Rollers

1. Disengage the power take off (PTO) and turn the ignition key to off. Move controllers to neutral locked position and apply parking brake. Remove the key.
2. After adjusting height-of-cut remove nut and washer while holding stud with wrench (Fig. 21).

**Note:** Do not remove the wheel nut and washer (Fig. 21).

3. Select hole so gage wheel is positioned to the nearest corresponding height-of-cut desired (Fig. 21).
4. Reinstall the flange nut and spring disk. Torque to 40–45 ft-lb (54.2–61.0 N•m) (Fig. 21).
5. Repeat adjustment on other gage wheels.

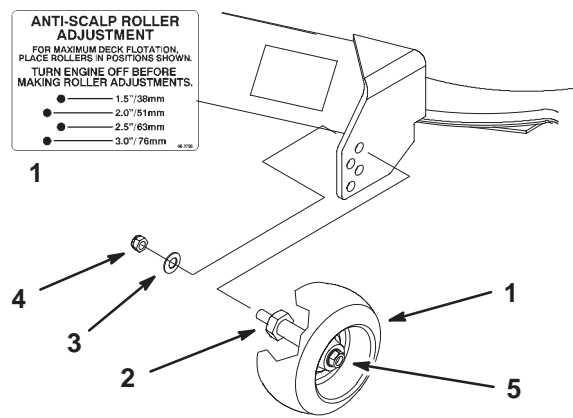

**Figure 21**

- 1. Gage wheel
- 2. Stud
- 3. Washer
- 4. Nut
- 5. Wheel nut and washer. Do not remove.

### Adjusting the Center Rollers

1. Disengage the power take off (PTO) and turn the ignition key to off. Move controllers to neutral locked position and apply parking brake.
2. After adjusting height-of-cut, remove bolt and nut (Fig. 22).
3. Select hole so gage wheel is positioned to the nearest corresponding height-of-cut desired (Fig. 22).

**Note:** Do not adjust rollers to support the deck.

4. Reinstall the bolt, center rollers and nut (Fig. 22).

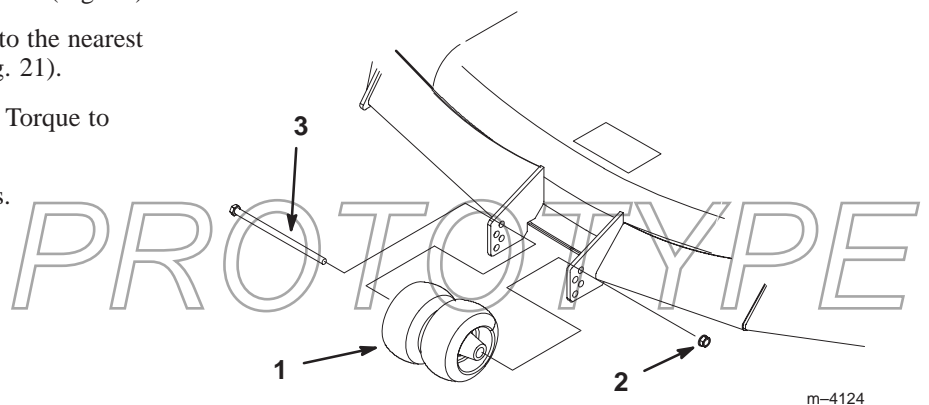

**Figure 22**

- 1. Center rollers and spacer
- 2. Nut
- 3. Bolt

## Positioning the Seat

The seat can move forward and backward. Position the seat where you have the best control of the machine and are most comfortable.

1. To adjust, move the lever sideways to unlock seat (Fig. 23).
2. Slide the seat to the desired position and release lever to lock in position.

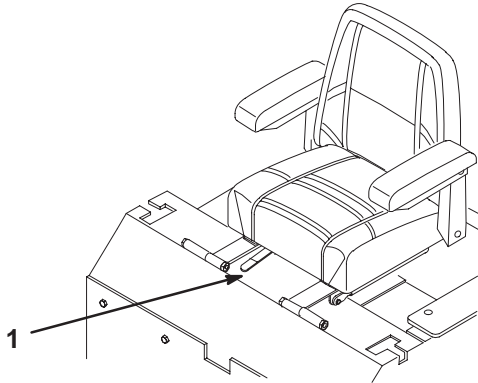

**Figure 23**

1. Adjustment lever

m-3655

**Note:** Do not over tighten the by-pass valves.

**Note:** The machine will not drive unless by-pass valves are turned in.

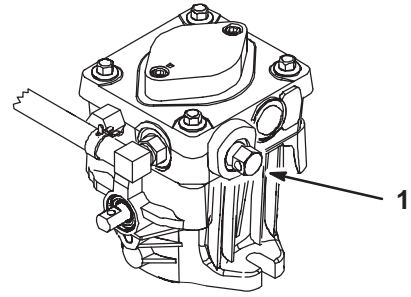

m-6279

**Figure 24**

1. By-pass valve

## Using a Rollover Protection System

Rollover protection systems (ROPS) are available for many riding machines. Contact an Authorized Service Dealer for information on obtaining ROPS for your machine.

## Operating with Side Discharge

The mower has a hinged grass deflector that disperses clippings to the side and down toward the turf.

## Pushing the Machine by Hand

**Important** Always push the machine by hand. Never tow the machine because hydraulic damage may occur.

### To Push the Machine

1. Disengage the power take off (PTO) and turn the ignition key to off. Move levers to neutral locked position and apply parking brake.
2. Rotate the by-pass valves counterclockwise 1 turn to push. This allows hydraulic fluid to by-pass the pump enabling the wheels to turn (Fig. 24).

**Important** Do not rotate by-pass valves more than 1 turn. This prevents valves from coming out of the body and causing fluid to run out.

3. Disengage parking brake before pushing.

### Changing to Machine Operation

1. Rotate the by-pass valves clockwise 1 turn to operate machine (Fig. 24).

PROTOTYPE



## Danger



Without the grass deflector, discharge cover, or complete grass catcher assembly mounted in place, you and others are exposed to blade contact and thrown debris. Contact with rotating mower blade(s) and thrown debris will cause injury or death.

- Never remove the grass deflector from the mower because the grass deflector routes material down toward the turf. If the grass deflector is ever damaged, replace it immediately.
- Never put your hands or feet under the mower.
- Never try to clear discharge area or mower blades unless you move the power take off (PTO) to off and rotate the ignition key to off. Also remove the key and pull the wire off the spark plug(s).

## Transporting Machines

Use a heavy-duty trailer or truck to transport the machine. Ensure that the trailer or truck has all necessary lighting and marking as required by law. Please carefully read all the safety instructions. Knowing this information could help you, your family, pets or bystanders avoid injury.

To transport the machine:

- Lock brake and block wheels.
- Securely fasten the machine to the trailer or truck with straps, chains, cable, or ropes.
- Secure a trailer to towing vehicle with safety chains.



## Warning



Driving on street or roadway without turn signals, lights, reflective markings, or a slow moving vehicle emblem is dangerous and can lead to accidents causing personal injury.

Do not drive machine on a public street or roadway.

## Loading Machines

Use extreme caution when loading units on trailers or trucks. One full width ramp that is wide enough to extend beyond the rear tires is recommended instead of individual ramps for each side of the unit. The lower rear section of the tractor frame extends back between the rear wheels and serves as a stop for tipping backward. Having a full width ramp provides a surface for the frame members to contact if the unit starts to tip backward. If it is not possible to use one full width ramp, use enough individual ramps to simulate a full width continuous ramp.

Ramp should be long enough so that the angles between the ramp and the ground and the ramp and the trailer or truck do not exceed 15 degrees. A steeper angle may cause mower deck components to get caught as the unit moves from ramp to trailer or truck. Steeper angles may also cause the unit to tip backward. If loading on or near a slope, position the trailer or truck so it is on the down side of the slope and the ramp extends up the slope. This will minimize the ramp angle. The trailer or truck should be as level as possible.

**Important** Do not attempt to turn the unit while on the ramp; you may lose control and drive off the side.

Avoid sudden acceleration when driving up a ramp and sudden deceleration when backing down a ramp. Both maneuvers can cause the unit to tip backward.



## Warning



Loading a unit onto a trailer or truck increases the possibility of backward tip-over and could cause serious injury or death.

- Use extreme caution when operating a unit on a ramp.
- Use only a single, full width ramp; Do not use individual ramps for each side of the unit.
- If individual ramps must be used, use enough ramps to create an unbroken ramp surface wider than the unit.
- Do not exceed a 15 degree angle between ramp and ground or between ramp and trailer or truck.
- Avoid sudden acceleration while driving unit up a ramp to avoid tipping backward.
- Avoid sudden deceleration while backing unit down a ramp to avoid tipping backward.

# Tips for Mowing Grass

## Fast Throttle Setting

For best mowing and maximum air circulation, operate the engine at fast. Air is required to thoroughly cut grass clippings, so do not set the height-of-cut so low as to totally surround the mower by uncut grass. Always try to have one side of the mower free from uncut grass, which allows air to be drawn into the mower.

## Cutting a Lawn for the First Time

Cut grass slightly longer than normal to ensure the cutting height of the mower does not scalp any uneven ground. However, the cutting height used in the past is generally the best one to use. When cutting grass longer than six inches tall, you may want to cut the lawn twice to ensure an acceptable quality of cut.

## Cut 1/3 of the Grass Blade

It is best to cut only about 1/3 of the grass blade. Cutting more than that is not recommended unless grass is sparse, or it is late fall when grass grows more slowly.

## Mowing Direction

Alternate mowing direction to keep the grass standing straight. This also helps disperse clippings which enhances decomposition and fertilization.

## Mow at Correct Intervals

Normally, mow every four days. But remember, grass grows at different rates at different times. So to maintain the same cutting height, which is a good practice, mow more often in early spring. As the grass growth rate slows in mid summer, mow less frequently. If you cannot mow for an extended period, first mow at a high cutting height; then mow again two days later at a lower height setting.

## Cutting Speed

To improve cut quality, use a slower ground speed.

## Avoid Cutting Too Low

If the cutting width of the mower is wider than the mower you previously used, raise the cutting height to ensure that uneven turf is not cut too short.

## Long Grass

If the grass is ever allowed to grow slightly longer than normal, or if it contains a high degree of moisture, raise the cutting height higher than usual and cut the grass at this setting. Then cut the grass again using the lower, normal setting.

## When Stopping

If the machine's forward motion must be stopped while mowing, a clump of grass clippings may drop onto your lawn. To avoid this, move onto a previously cut area with the blades engaged.

## Keep the Underside of the Mower Clean

Clean clippings and dirt from the underside of the mower after each use. If grass and dirt build up inside the mower, cutting quality will eventually become unsatisfactory.

## Blade Maintenance

Maintain a sharp blade throughout the cutting season because a sharp blade cuts cleanly without tearing or shredding the grass blades. Tearing and shredding turns grass brown at the edges, which slows growth and increases the chance of disease. Check the cutter blades daily for sharpness, and for any wear or damage. File down any nicks and sharpen the blades as necessary. If a blade is damaged or worn, replace it immediately with a genuine TORO replacement blade.

PROTOTYPE

# Maintenance

## Recommended Maintenance Schedule

Maintenance Service Interval	Maintenance Procedure
After First Use	<ul style="list-style-type: none"> <li>• Check hydraulic fluid level</li> <li>• Change engine oil</li> <li>• Change hydraulic filter</li> </ul>
Each Use	<ul style="list-style-type: none"> <li>• Check oil level</li> <li>• Check safety system</li> <li>• Clean cooling systems</li> <li>• Clean mower housing</li> </ul>
Every 5 Hours	<ul style="list-style-type: none"> <li>• Check cutting blades</li> <li>• Grease blade spindle bearings</li> </ul>
Every 25 Hours	<ul style="list-style-type: none"> <li>• Check hydraulic fluid level</li> <li>• Grease chassis<sup>1</sup></li> <li>• Oil linkage bushings<sup>1</sup></li> <li>• Service foam air cleaner<sup>1</sup></li> <li>• Check belts for wear/cracks</li> <li>• Check battery electrolyte</li> <li>• Check tire pressure</li> <li>• Idler pulley pivot</li> </ul>
Every 100 Hours	<ul style="list-style-type: none"> <li>• Change oil<sup>1</sup></li> <li>• Service paper air cleaner<sup>1</sup></li> <li>• Check spark plug(s)</li> <li>• Check hydraulic lines</li> </ul>
Every 200 Hours	<ul style="list-style-type: none"> <li>• Change oil filter</li> <li>• Change hydraulic filter</li> <li>• Replace fuel filter</li> </ul>
Every 300 Hours	<ul style="list-style-type: none"> <li>• Replace paper air cleaner<sup>1</sup></li> </ul>
Every 500 Hours or Storage	<ul style="list-style-type: none"> <li>• Adjust caster pivot</li> <li>• Adjust Wheel Hub Slotted Nut</li> </ul>
Before Storage	<ul style="list-style-type: none"> <li>• Perform all maintenance procedures listed above before storage</li> <li>• Drain gasoline</li> <li>• Charge battery, disconnect cables</li> <li>• Paint chipped surfaces</li> </ul>

<sup>1</sup>More often in dusty, dirty conditions

**Important** Refer to your engine operator's manual for additional maintenance procedures.



## Caution



If you leave the key in the ignition switch, someone could accidentally start the engine and seriously injure you or other bystanders.

Remove the key from the ignition and disconnect the wire from the spark plug(s) before you do any maintenance. Set the wire aside so that it does not accidentally contact the spark plug.

## Servicing the Cutting Blades

Maintain sharp blades throughout the cutting season because sharp blades cut cleanly without tearing or shredding the grass blades. Tearing and shredding turns grass brown at the edges, which slows growth and increases the chance of disease.

Check the cutter blades daily for sharpness, and for any wear or damage. File down any nicks and sharpen the blades as necessary. If a blade is damaged or worn, replace it immediately with a genuine TORO replacement blade. For convenient sharpening and replacement, you may want to keep extra blades on hand.



## Danger



A worn or damaged blade can break, and a piece of the blade could be thrown into the operator's or bystander's area, resulting in serious personal injury or death.

- Inspect the blade periodically for wear or damage.
- Replace a worn or damaged blade.

## Before Inspecting or Servicing the Blades

Disengage the blade control (PTO) and set the parking brake. Turn the ignition key to off. Remove the key and disconnect the spark plug wire(s) from the spark plug(s).

## Inspecting the Blades

1. Inspect the cutting edges (Fig 25). If the edges are not sharp or have nicks, remove and sharpen the blades. Refer to Sharpening the Blades on page 28.
2. Inspect the blades, especially the curved area (Fig. 25). If you notice any damage, wear, or a slot forming in this area (item 3 in Fig. 25), immediately install a new blade.

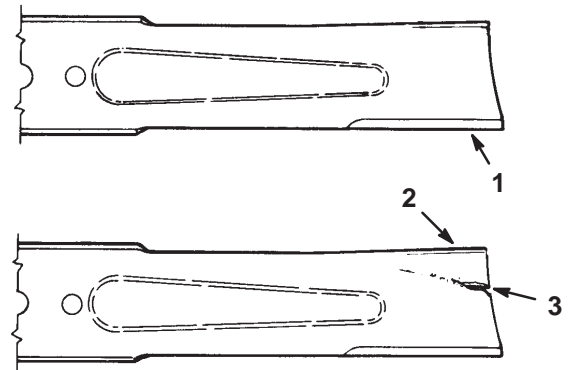

m-151

Figure 25

1. Cutting edge
2. Curved area
3. Wear/slot forming

## Checking for Bent Blades

1. Rotate the blades until the ends face forward and backward (Fig. 26). Measure from a level surface to the cutting edge of the blades (Fig. 27). Note this dimension.

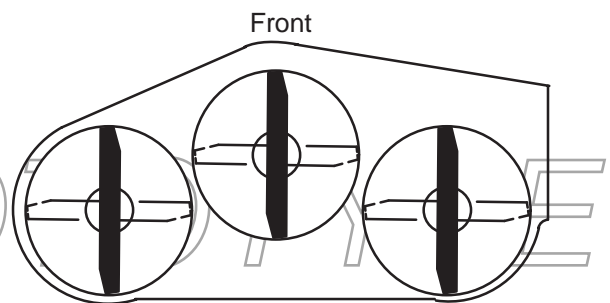

m-1078

Figure 26

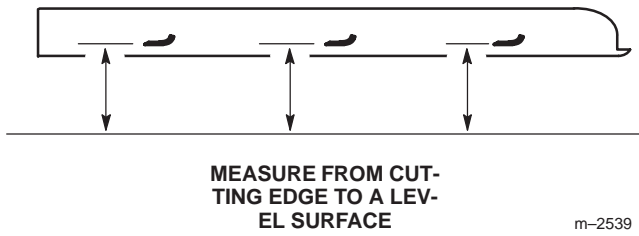

Figure 27

m-2539

2. Rotate the opposite ends of the blades forward.
3. Measure from a level surface to the cutting edge of the blades at the same position as in step 1 above. The difference between the dimensions obtained in steps 1 and 2 must not exceed 1/8 inch (3 mm). If this dimension exceeds 1/8 inch (3 mm), the blade is bent and must be replaced. Refer to Removing the Blades, and Installing the Blades on page 29.

**Warning**

**A blade that is bent or damaged could break apart and could seriously injure or kill you or bystanders.**

- Always replace bent or damaged blade with a new blade.
- Never file or create sharp notches in the edges or surfaces of blade.

### Removing the Blades

Blades must be replaced if a solid object is hit, if the blade is out of balance or is bent. To ensure optimum performance and continued safety conformance of the machine, use genuine TORO replacement blades. Replacement blades made by other manufacturers may result in non-conformance with safety standards.

**Warning**

**Contact with sharp blade can cause serious injury.**

**Wear gloves or wrap sharp edges of the blade with a rag.**

Hold the blade end using a rag or thickly-padded glove. Remove the blade bolt, flat washer, split lockwasher and blade from the spindle shaft (Fig. 28).

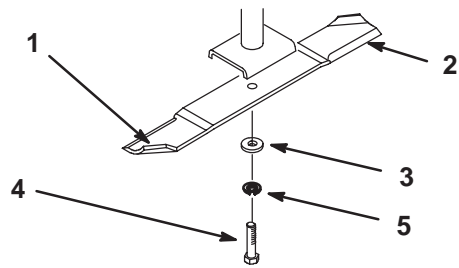

Figure 28

m-4318

- |                       |                     |
|-----------------------|---------------------|
| 1. Sail area of blade | 4. Blade bolt       |
| 2. Blade              | 5. Split lockwasher |
| 3. Flat washer        |                     |

### Sharpening the Blades

**Warning**

**When sharpening blade, pieces of blade could be thrown and cause serious injury.**

**Wear proper eye protection when sharpening blade.**

1. Use a file to sharpen the cutting edge at both ends of the blade (Fig. 29). Maintain the original angle. The blade retains its balance if the same amount of material is removed from both cutting edges.

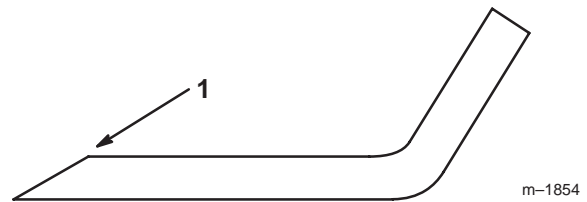

Figure 29

m-1854

1. Sharpen at original angle

2. Check the balance of the blade by putting it on a blade balancer (Fig. 30). If the blade stays in a horizontal position, the blade is balanced and can be used. If the blade is not balanced, file some metal off the end of the sail area only (Fig. 28). Repeat this procedure until the blade is balanced.

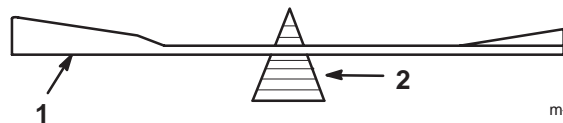

Figure 30

m-1855

- |          |             |
|----------|-------------|
| 1. Blade | 2. Balancer |
|----------|-------------|

## Installing the Blades

1. Install the blade onto the spindle shaft (Fig. 28).

**Important** The curved part of the blade must be pointing upward toward the inside of the mower to ensure proper cutting.

2. Install the flat washer, lock washer and blade bolt (Fig. 28). Torque the blade bolt to 85–110 ft-lb (115–150 N•m).

**Important** Make sure blade is torqued to 85–110 ft-lb (115–150 N•m).

## Servicing the Air Cleaner

Foam Element: Clean and re-oil after every 25 operating hours.

Paper Element: Clean after every 100 operating hours. Replace after every 300 operating hours or yearly. Which ever comes first.

**Note:** Service the air cleaner more frequently (every few hours) if operating conditions are extremely dusty or sandy.

## Removing the Foam and Paper Elements

1. Disengage the power take off (PTO), set the parking brake, and turn the ignition key to off. Remove the key.
2. Clean around the air cleaner to prevent dirt from getting into the engine and causing damage. Unlatch two side latches and remove the air cleaner cover (Fig. 31).

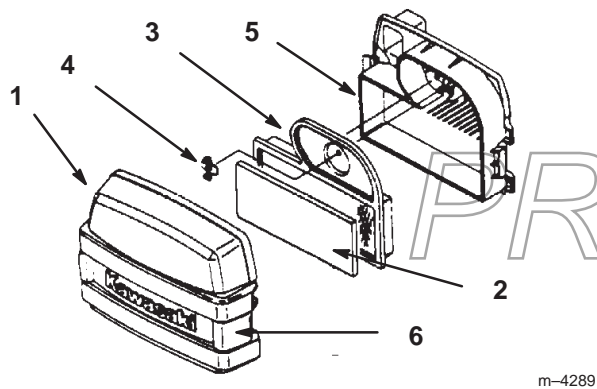

Figure 31

- |                  |                     |
|------------------|---------------------|
| 1. Cover         | 4. Wing nut         |
| 2. Foam element  | 5. Air cleaner base |
| 3. Paper element | 6. Latches          |

3. Carefully remove the foam element from the paper element (Fig. 31).

4. Unscrew the wing nut and remove the paper element (Fig. 31).

## Cleaning the Foam Element

1. Wash the foam element in liquid soap and warm water. When the element is clean, rinse it thoroughly.
2. Dry the element by squeezing it in a clean cloth (do not wring).
3. Soak element in new engine oil. (Fig. 32). Squeeze the element to remove excess oil.

**Important** Replace the foam element if it is torn or worn.

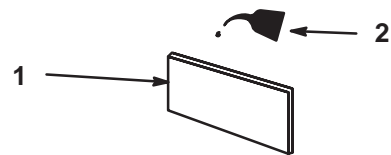

Figure 32

- |                 |        |
|-----------------|--------|
| 1. Foam element | 2. Oil |
|-----------------|--------|

## Cleaning the Paper Element

1. Lightly tap the element on a flat surface to remove dust and dirt (Fig. 33).
2. Inspect the element for tears, an oily film, and damage to the rubber seal.

**Important** Never clean the paper element with pressurized air or liquids, such as solvent, gas, or kerosene. Replace the paper element if it is damaged or cannot be cleaned thoroughly.

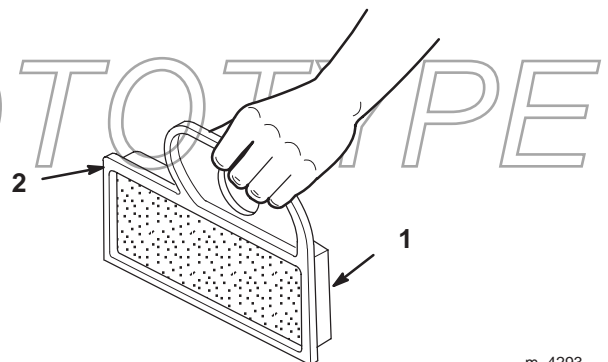

Figure 33

- |                  |                |
|------------------|----------------|
| 1. Paper element | 2. Rubber seal |
|------------------|----------------|

## Installing the Foam and Paper Elements

**Important** To prevent engine damage, always operate the engine with the complete foam and paper air cleaner assembly installed.

1. Carefully slide the foam element into the paper air cleaner element (Fig. 31).
2. Place the air cleaner assembly onto the air cleaner base and install wing nut (Fig. 31).
3. Install the air cleaner cover and latch (Fig. 31).

## Servicing the Engine Oil

Change oil:

- After the first 8 operating hours.
- After every 100 operating hours.

**Note:** Change oil more frequently when operating conditions are extremely dusty or sandy.

Oil Type: Detergent oil (API service SG or SH)

Crankcase Capacity: w/filter, 61 oz. (1.8 l)

Viscosity: See table below

### USE THESE SAE VISCOSITY OILS

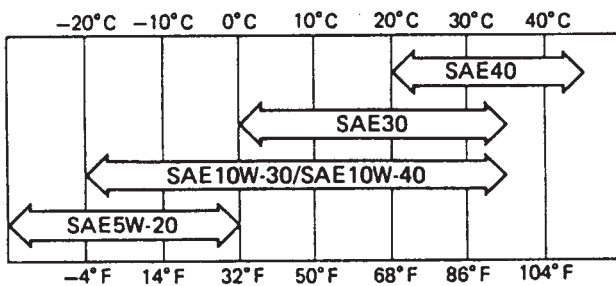

## Checking the Engine Oil Level

1. Park the machine on a level surface, disengage the power take off (PTO) and turn the ignition key to off. Remove the key.
2. Clean around the oil dipstick (Fig. 34) so dirt cannot fall into the filler hole and damage the engine.
3. Unscrew the oil dipstick and wipe the end clean (Fig. 34).

4. Slide the oil dipstick fully into the filler tube, do not thread onto tube (Fig. 34). Pull the dipstick out and look at the end. If oil level is low, slowly pour only enough oil into the filler tube to raise the level to the *full* mark.

**Important** Do not overfill the crankcase with oil because the engine may be damaged.

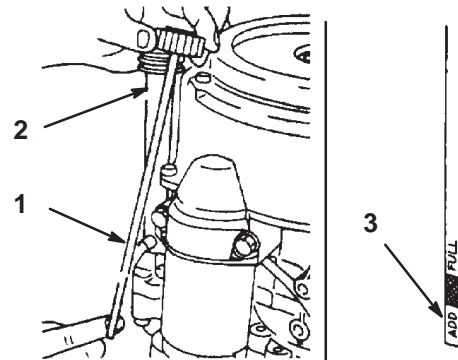

m-4291

Figure 34

1. Oil dipstick
2. Filler tube
3. Dipstick end

## Changing the Engine Oil

1. Start the engine and let it run five minutes. This warms the oil so it drains better.
2. Park the machine so that the drain side is slightly lower than the opposite side to assure the oil drains completely. Then disengage the power take off (PTO), set the parking brake, and turn the ignition key to off. Remove the key.
3. Place a pan below the oil drain. Use either a flat screw driver, 3/8 inch or 10 mm wrench to open valve (Fig. 35).
4. Rotate valve end clockwise to close valve. Rotate valve end counterclockwise to open valve (Fig. 35).
5. When oil has drained completely, close the drain valve (Fig. 35).

**Note:** Dispose of the used oil at a recycling center.

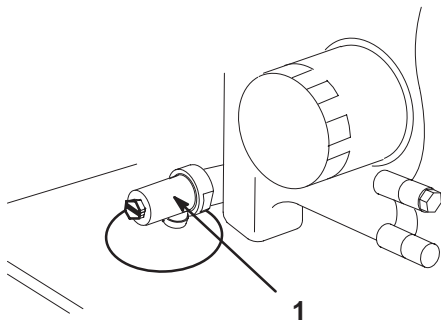

m-4674

**Figure 35**

1. Oil drain valve

6. Slowly pour approximately 80% of the specified oil into the filler cap (Fig. 34). Refer to Servicing the Engine Oil, page 30.
7. Check the oil level; refer to Checking the Oil Level, page 30.
8. Slowly add additional oil to bring it to the full mark.

## Changing the Oil Filter

Replace the oil filter every 200 hours or every other oil change.

**Note:** Change oil filter more frequently when operating conditions are extremely dusty or sandy.

1. Drain the oil from the engine; refer to Changing the Engine Oil, page 30.
2. Remove the old filter (Fig. 36).
3. Apply a thin coat of new oil to the rubber gasket on the replacement filter (Fig. 36).

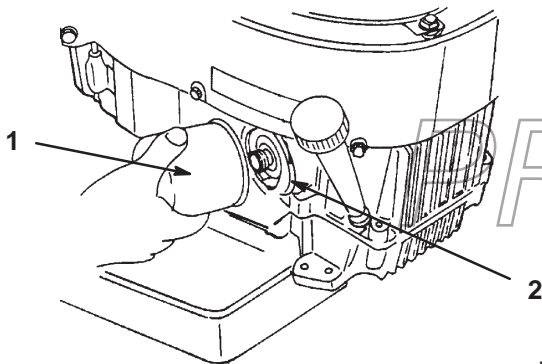

M-4288

**Figure 36**

1. Oil filter
2. Adapter

4. Install the replacement oil filter to the adapter. Turn the oil filter clockwise until the rubber gasket contacts the filter adapter, then tighten the filter an additional 3/4 turn (Fig. 36).

5. Fill the crankcase with the proper type of new oil; refer to Changing the Engine Oil, page 30.

## Servicing the Spark Plug

Check the spark plug(s) after every 100 operating hours. Make sure the air gap between the center and side electrodes is correct before installing the spark plug. Use a spark plug wrench for removing and installing the spark plug(s) and a gapping tool/feeler gauge to check and adjust the air gap. Install a new spark plug(s) if necessary.

Type: Champion RCJ8Y (or equivalent)

Air Gap: 0.040 inch (1.0 mm)

### Removing the Spark Plug(s)

1. Disengage the power take off (PTO), set the parking brake, and turn the ignition key to off. Remove the key.
2. Pull the wire(s) off the spark plug(s) (Fig. 37). Now clean around the spark plug(s) to prevent dirt from falling into the engine and potentially causing damage.
3. Remove the spark plug(s).

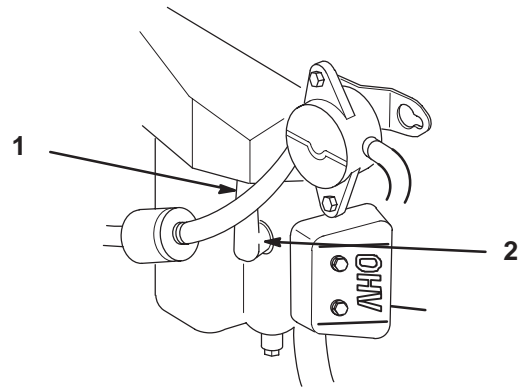

M-4294

**Figure 37**

1. Spark plug wire installed
2. Spark plug

### Checking the Spark Plug

1. Look at the center of the spark plug(s) (Fig. 38). If you see light brown or gray on the insulator, the engine is operating properly. A black coating on the insulator usually means the air cleaner is dirty.

**Important** Never clean the spark plug(s). Always replace the spark plug(s) when it has a black coating, worn electrodes, an oily film, or cracks.

2. Check the gap between the center and side electrodes (Fig. 38). Bend the side electrode (Fig. 38) if the gap is not correct.

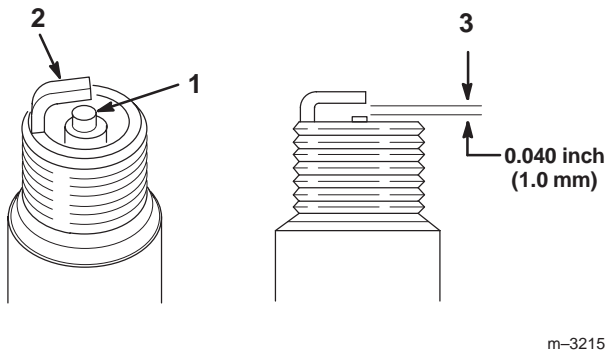

**Figure 38**

1. Center electrode insulator
2. Side electrode
3. Air gap (not to scale)

m-3215

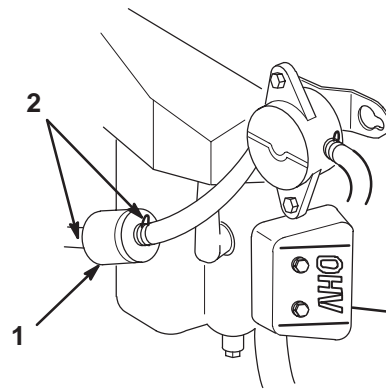

**Figure 39**

1. Filter
2. Hose clamp

M-4294

## Installing the Spark Plug(s)

1. Install the spark plug(s). Make sure the air gap is set correctly.
2. Tighten the spark plug(s) to 11 ft-lb (15 N.m).
3. Push the wire(s) onto the spark plug(s) (Fig. 37).

## Servicing the Fuel Filter

Replace the fuel filter after every 200 operating hours or yearly, whichever occurs first.

### Replacing the Fuel Filter

Never install a dirty filter if it is removed from the fuel line.

1. Disengage the power take off (PTO), set the parking brake, and turn the ignition key to off. Remove the key.
2. Close fuel shut-off valve on console.
3. Squeeze the ends of the hose clamps together and slide them away from the filter (Fig. 39).
4. Remove the filter from the fuel lines.
5. Install a new filter and move the hose clamps close to the filter (Fig. 40).
6. Open fuel shut-off valve on console.

## Servicing the Fuel Tank

### Draining The Fuel Tank

⚠
Danger
⚠

**In certain conditions, gasoline is extremely flammable and highly explosive. A fire or explosion from gasoline can burn you and others and can damage property.**

- **Drain gasoline from the fuel tank when the engine is cold. Do this outdoors in an open area. Wipe up any gasoline that spills.**
- **Never smoke when draining gasoline, and stay away from an open flame or where a spark may ignite the gasoline fumes.**

1. Park the machine on a level surface, to assure fuel tanks drain completely. Then disengage the power take off (PTO), set the parking brake, and turn the ignition key to off. Remove the key.
2. Close fuel shut-off valve (Fig. 40).
3. Loosen the hose clamp at the fuel filter and slide it up the fuel line away from the fuel filter (Fig. 40).
4. Pull the fuel line off fuel filter (Fig. 40).
5. Open fuel shut-off valve for left and right tanks. Allow gasoline to drain into a gas can or drain pan. (Fig. 40).

**Note:** Now is the best time to install a new fuel filter because the fuel tank is empty.

6. Install the fuel line onto the fuel filter. Slide the hose clamp close to the fuel filter to secure the fuel line (Fig. 40).

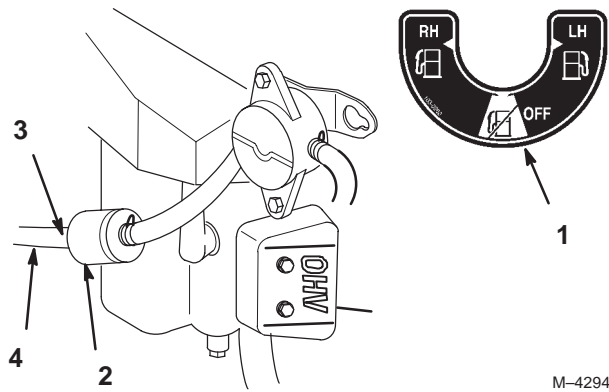

**Figure 40**

- |                        |               |
|------------------------|---------------|
| 1. Fuel shut-off valve | 3. Hose clamp |
| 2. Fuel filter         | 4. Fuel line  |

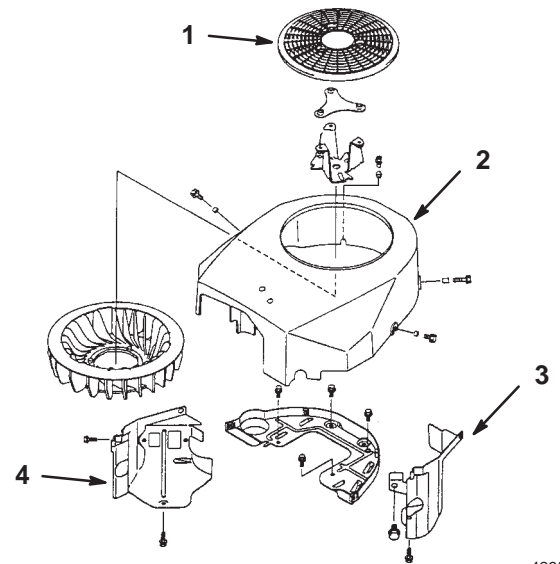

**Figure 41**

- |                      |                   |
|----------------------|-------------------|
| 1. Air intake screen | 3. Cylinder cover |
| 2. Fan housing       | 4. Cylinder cover |

## Cleaning the Cooling System

Clean the air intake screen from grass and debris before each use.

Clean cooling fins and engine shrouds every 300 hours or yearly, whichever comes first.

1. Stop the engine, set the parking brake, remove the key and disconnect the spark plug wire(s) from the spark plug(s).
2. Remove air intake screen, cylinder covers and fan housing.
3. Clean debris and grass from parts.
4. Reinstall air intake screen, cylinder covers and fan housing.

## Greasing and Lubrication

Lubricate the machine when shown on the **Check Service Reference Aid** decal (Fig. 42). Grease more frequently when operating conditions are extremely dusty or sandy.

Grease with No. 2 general purpose lithium base or molybdenum base grease.

### How to Grease

1. Disengage the power take off (PTO) and turn the ignition key to off. Move levers to neutral locked position and apply parking brake. Remove the key.
2. Clean the grease fittings with a rag. Make sure to scrape any paint off the front of the fitting(s).
3. Connect a grease gun to the fitting. Pump grease into the fittings until grease begins to ooze out of the bearings.
4. Wipe up any excess grease.

### Where to Add Grease

Lubricate the grease fittings as shown on the **Check Service Reference Aid** decal (Fig. 42).

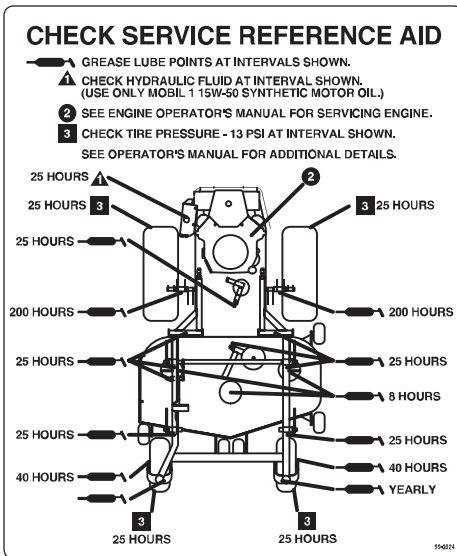
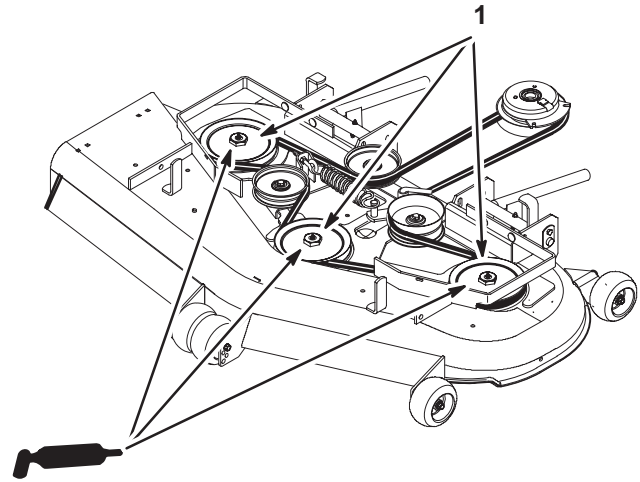

Figure 42



M-4269

Figure 43

## Greasing the Front Caster Pivots

Lubricate the front caster pivots once a year.

1. Remove the dust cap and adjust the caster pivots. Keep dust cap off until greasing is done. Refer to Adjusting the Caster Pivot Bearing, page 35.
2. Remove the hex plug. Thread a grease zerk into hole.
3. Pump grease into zerk until it oozes out around top bearing.
4. Remove grease zerk in hole. Reinstall hex plug and cap.

## Greasing the Bearings

The cutting unit must be lubricated regularly. Refer to the Recommended Maintenance Schedule on page 26. Grease with No. 2 general purpose lithium base or molybdenum base grease.

1. Stop the engine, set the parking brake, remove the key and disconnect the spark plug wire(s) from the spark plug(s).
2. Grease the fittings on the three spindle bearings (Fig. 43).
3. Grease the idler pulley pivot (Fig. 43).
4. Grease the fittings on the push arms (Fig. 43).

## Where to Add Light Oil or Spray Lubrication

Lubricate the machine in the following areas with spray type lubricant or light oil. Lubricate every 160 hours.

- Seat switch actuator.
- Brake handle pivot.
- Brake rod bushings.
- Motion control bronze bushings.

## Checking the Tire Pressure

Maintain the air pressure in the front and rear tires as specified. Uneven tire pressure can cause uneven cut. Check the pressure at the valve stem after every 50 operating hours or monthly, whichever occurs first (Fig. 44). Check the tires when they are cold to get the most accurate pressure reading.

Pressure: 13 psi (90 kPa) drive wheels and caster wheels.

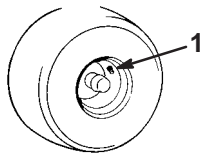

m-1872

**Figure 44**

1. Valve stem

## Adjusting the Wheel Hub Slotted Nut

Check after every 500 operating hours.

The slotted nut needs to be torqued to 125 ft-lb (170 N•m).

1. Stop the engine, set the parking brake, remove the key and disconnect the spark plug wire(s) from the spark plug(s).
2. Remove cotter pin.
3. Torque slotted nut to 125 ft-lb (170 N•m) (Fig. 45).
4. Check the distance from bottom of slot in nut to inside edge of hole. Two threads or less should be showing (Fig. 45).
5. If more than two threads are showing remove nut and install washer between hub and nut (Fig. 45).
6. Torque the slotted nut to 125 ft-lb (170 N•m) (Fig. 45).
7. Tighten nut until the next set of slots line up with the hole in the shaft (Fig. 45).
8. Replace cotter pin.

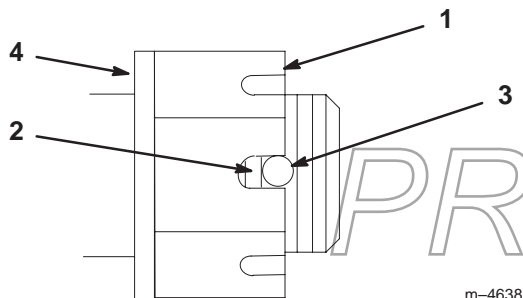

m-4638

**Figure 45**

- |                                |                         |
|--------------------------------|-------------------------|
| 1. Slotted nut                 | 3. Hole in threaded rod |
| 2. Two threads or less showing | 4. Washer (if needed)   |

## Adjusting the Caster Pivot Bearing

Check after every 500 operating hours or at storage, whichever comes first.

1. Stop the engine, set the parking brake, remove the key and disconnect the spark plug wire(s) from the spark plug(s).
2. Remove dust cap from caster and tighten lock nut (Fig. 46).
3. Tighten until spring washers are flat and then back off a 1/4 turn to properly set the pre-load on the bearings (Fig. 46).
4. Grease caster pivot. Refer to Greasing and Lubrication on page 33.

**Important** Make sure spring washers are installed correctly as shown in figure 46.

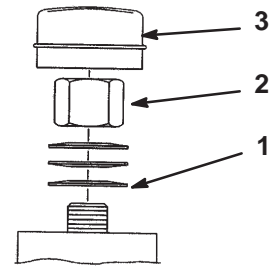

M-4640

**Figure 46**

- |                   |             |
|-------------------|-------------|
| 1. Spring washers | 3. Dust cap |
| 2. Lock nut       |             |

## Servicing the Hydraulic System

### Checking the Hydraulic Fluid

Check the hydraulic fluid level before engine is first started.

Check the hydraulic fluid level after first 8 operating hours.

Check the hydraulic fluid level after every 25 operating hours.

Fluid Type: Mobil 1 15W-50 synthetic motor oil or equivalent synthetic oil.

**Important** Use oil specified or equivalent. Other fluids could cause system damage.

Hydraulic System Oil Capacity: 67 oz. (2.0 l)

**Note:** There are two ways of checking the hydraulic oil. One is when the oil is warm and one is when the oil is cold. The baffle inside the tank has two levels depending if the oil is warm or cold.

1. Position machine on a level surface and set the parking brake.
2. Clean area around filler neck of hydraulic tank (Fig. 47).
3. Remove cap from filler neck. Look inside to check if there is fluid in the reservoir. (Fig. 47).
4. If there is no fluid, add fluid to the reservoir until it reaches the *cold* level of the baffle.
5. Run the machine at low idle for 15 minutes to allow any air to purge out of the system and warm fluid. Refer to Starting and Stopping the Engine on page 18.
6. Recheck the fluid level while the fluid is warm. If required, add fluid to the reservoir until it reaches the *hot* level of the baffle.

**Note:** The fluid level should be to the top of the *hot* level of the baffle, when the fluid is warm (Fig. 47).

7. Install cap on filler neck.

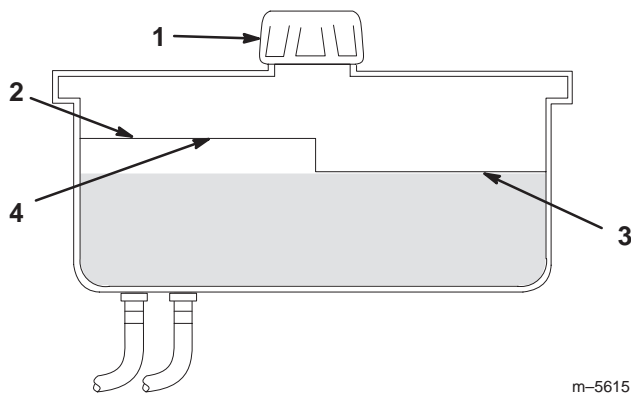

**Figure 47**

- |           |                          |
|-----------|--------------------------|
| 1. Cap    | 3. Cold fluid level—full |
| 2. Baffle | 4. Hot fluid level—full  |

! **Warning** !

**Hydraulic fluid escaping under pressure can penetrate skin and cause injury.**

- **If hydraulic fluid is injected into the skin it must be surgically removed within a few hours by a doctor familiar with this type of injury. Gangrene may result if this is not done.**
- **Keep body and hands away from pin hole leaks or nozzles that eject high pressure hydraulic fluid.**
- **Use cardboard or paper to find hydraulic leaks.**
- **Safely relieve all pressure in the hydraulic system before performing any work on the hydraulic system.**
- **Make sure all hydraulic fluid hoses and lines are in good condition and all hydraulic connections and fittings are tight before applying pressure to hydraulic system.**

## Replacing the Hydraulic Filter

Change the hydraulic filter:

- After the first 8 operating hours.
  - After every 200 operating hours.
1. Position machine on a level surface, stop the engine, and remove key from ignition switch.

**Important** Do not substitute automotive oil filter or severe hydraulic system damage may result.

2. Remove hydro cap and temporarily cover opening with a plastic bag and rubber band to prevent all hydro fluid from draining out.
3. Place drain pan under filter, remove the old filter and wipe the filter adapter gasket surface clean (Fig. 48).

PROTOTYPE

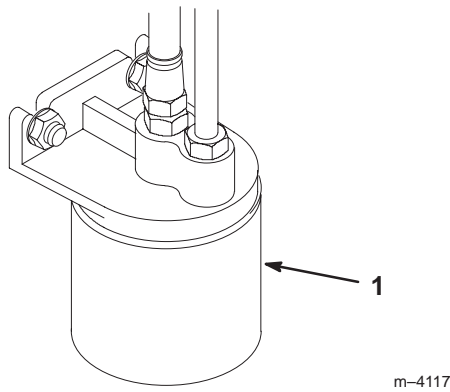

**Figure 48**

1. Hydraulic filter

4. Apply a thin coat hydro fluid to the rubber gasket on the replacement filter (Fig. 49).
5. Install replacement hydraulic filter onto the filter adapter. Do not tighten.
6. Remove plastic bag from tank opening and allow filter to fill with hydro fluid.
7. When fluid overflows filter turn the oil filter clockwise until the rubber gasket contacts the filter adapter, then tighten the filter an additional 1/2 turn (Fig. 49).

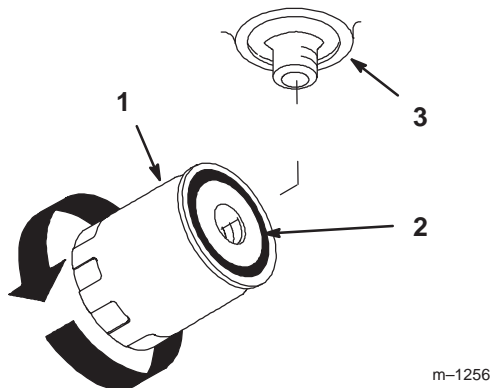

**Figure 49**

1. Hydraulic filter  
2. Gasket

3. Adapter

8. Clean up any spilled fluid.
9. If there is no fluid, add fluid to reservoir approximately a 1/4 inch (6mm) below the top of baffle.
10. Start engine and let run for about two minutes to purge air from the system. Stop the engine and check for leaks. If one or both wheels will not drive, refer Bleeding Hydraulic System, page 37.
11. Recheck level while fluid is warm. Add fluid to raise level to top of the baffle, if required. **Do not overfill.**

## Bleeding Hydraulic System

The traction system is self bleeding, however, it may be necessary to bleed the system if fluid is changed or after work is performed on the system.

1. Raise rear of the machine so wheels are off the ground and support with jack stands.
2. Start the engine and run at idle speed. Engage traction on one side and spin the wheel by hand.
3. When the wheel begins to spin on its own, keep it engaged until wheel drives smoothly (minimum 2 minute).
4. Check hydraulic fluid level as it drops and add as required to maintain proper level.
5. Repeat procedure on opposite wheel.

## Check Hydraulic Lines

After every 100 operating hours, check hydraulic lines and hoses for leaks, loose fittings, kinked lines, loose mounting supports, wear, weather and chemical deterioration. Make necessary repairs before operating.

**Note:** Keep areas around hydraulic system clean from grass and debris build up.



### Warning



Hydraulic fluid escaping under pressure can penetrate skin and cause injury.

- If hydraulic fluid is injected into the skin it must be surgically removed within a few hours by a doctor familiar with this type of injury. Gangrene may result if this is not done.
- Keep body and hands away from pin hole leaks or nozzles that eject high pressure hydraulic fluid.
- Use cardboard or paper to find hydraulic leaks.
- Safely relieve all pressure in the hydraulic system before performing any work on the hydraulic system.
- Make sure all hydraulic fluid hoses and lines are in good condition and all hydraulic connections and fittings are tight before applying pressure to hydraulic system.

## Adjusting the Handle Neutral

If motion control levers do not align, or move easily into the console notch, adjustment is required. Adjust each lever, spring and rod separately.

**Note:** Motion control levers must be installed correctly. See Installing the Motion Control Levers, page 15.

1. Stop the engine, remove ignition key and tilt seat forward.
2. Begin with either the left or right motion control lever.
3. Move lever to the neutral position but **not locked** (Fig. 50).
4. Pull lever back until the clevis pin (on arm below pivot shaft) contacts the end of the slot (just beginning to put pressure on the spring) (Fig. 51).
5. Check where the control lever is relative to notch in console (Fig. 50). It should be centered allowing lever to pivot outward to the neutral lock position.

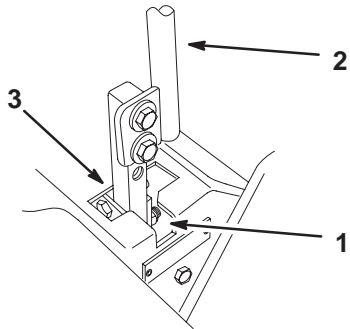

**Figure 50**

- |                            |                     |
|----------------------------|---------------------|
| 1. Neutral locked position | 3. Neutral position |
| 2. Control lever           |                     |

m-6282

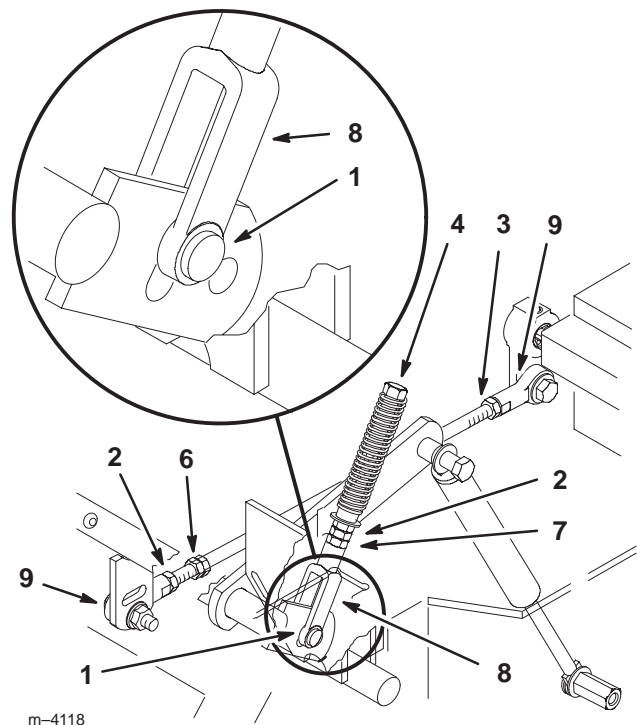

m-4118

**Figure 51**

- |                         |                |
|-------------------------|----------------|
| 1. Clevis pin in slot   | 6. Double nuts |
| 2. Nut                  | 7. Jam nut     |
| 3. Nut—Left hand thread | 8. Yoke        |
| 4. Adjustment bolt      | 9. Ball joint  |
| 5. Pump rod             |                |

6. If adjustment is needed, loosen the nut and jam nut against the yoke (Fig. 51).
  7. Apply slight rearward pressure on the motion control lever, turn the head of the adjustment bolt in the appropriate direction until the control lever is centered in neutral lock position (Fig. 50).
- Note:** Keeping rearward pressure on the lever will keep the pin at the end of the slot and allow the adjustment bolt to move the lever to the appropriate position.
8. Tighten the nut and jam nut (Fig. 51).
  9. Repeat on the opposite side of unit.

PROTOTYPE

## Setting the Hydraulic Pump Neutral

**Note:** Adjust handle neutral first. That has to be correct before the following adjustment can be made.

! **Danger** !

**Mechanical or hydraulic jacks may fail to support machine and cause a serious injury.**

- Use jack stand when supporting machine.
- Do not use hydraulic jacks.

! **Warning** !

**Engine must be running so motion control adjustment can be performed. Contact with moving parts or hot surfaces may cause personal injury.**

**Keep hands, feet, face, clothing and other body parts away from rotating parts, muffler and other hot surfaces.**

This adjustment must be made with drive wheels turning.

1. Raise the frame and block up the machine so drive wheels can rotate freely.
2. Disconnect electrical connector from the seat safety switch. **Temporarily** install a jumper wire across terminals in the wiring harness connector.
3. Slide seat forward, disconnect prop rod and tilt seat fully forward.

### Setting the Left-hand Hydraulic Pump Neutral

1. Start the engine, open throttle 1/2 way and release parking brake. Refer to Starting and Stopping the Engine, page 18.

**Note:** Motion control lever must be in neutral while making any adjustments.

2. Adjust pump rod length by rotating the knob, in the appropriate direction, until the wheel is still or slightly creeping in reverse (Fig. 52).
3. Move motion control lever forward and reverse, then back to neutral. Wheel must stop turning or slightly creep in reverse.

4. Open throttle to fast. Make sure wheel remains stopped or slightly creeps in reverse, adjust if necessary.

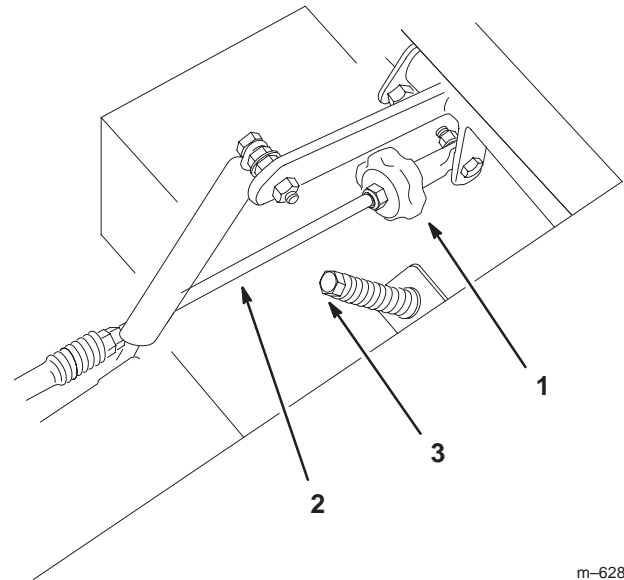

**Figure 52**

- |                  |                    |
|------------------|--------------------|
| 1. Tracking knob | 3. Adjustment bolt |
| 2. Pump rod      |                    |

### Setting the Right-hand Hydraulic Pump Neutral

1. Loosen the locknuts at the ball joints on pump control rod (Fig. 51).
2. Start the engine, open throttle 1/2 way and release parking brake. Refer to Starting and Stopping the Engine, page 18.

**Note:** Motion control lever must be in neutral while making any adjustments.

**Note:** The front nut on the pump rod has left-hand threads.

3. Adjust pump rod length by rotating double-nuts on rod, in the appropriate direction, until wheel is still or slightly creeps in reverse (Fig. 51).
4. Move motion control lever forward and reverse, then back to neutral. Wheel must stop turning or slightly creep in reverse.
5. Open throttle to fast. Make sure wheel remains stopped or slightly creeps in reverse, re-adjust if necessary.
6. Tighten the nuts at the ball joints (Fig. 51).

PROTOTYPE



## Warning



Electrical system will not perform proper safety shut off with jumper wire installed.

- Remove jumper wire from wire harness connector and plug connector into seat switch when adjustment is completed.
- Never operate this unit with jumper installed and seat switch bypassed.

7. After both pump neutrals are set, shut off the machine.
8. Remove jumper wire from wire harness connector and plug connector into seat switch.
9. Reinstall prop rod and lower the seat into position.

## Adjusting the Tracking

The left-hand pump has a knob for adjusting the tracking.

**Important** Adjust the handle neutral and hydraulic pump neutral before adjusting the tracking. Refer to Adjusting the Handle Neutral on page 37 and Adjusting the Hydraulic Pump Neutral on page 39.

1. Push both control levers forward the same distance.
2. Check if the machine pulls to one side. If it does, stop the machine and set the parking brake.
3. Tip the seat up to access the tracking knob.

**Note:** Determine the left and right sides of the machine from the normal operating position.

4. To make the machine go right, turn the knob towards the rightside of the machine. Refer to figure 53.
5. To make the machine go left, turn the knob towards the leftside of the machine. Refer to figure 53.
6. Repeat adjustment until the tracking is correct.

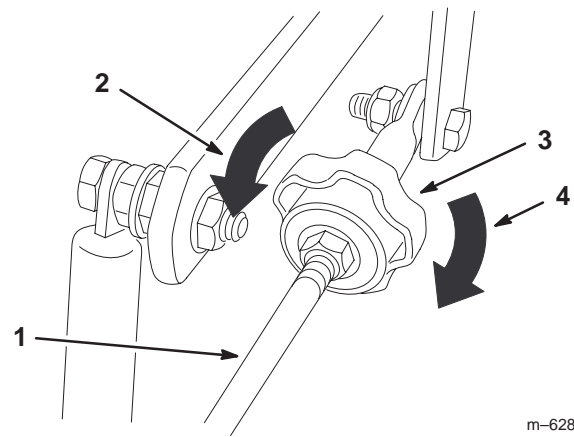

m-6280

Figure 53

- |                                |                                 |
|--------------------------------|---------------------------------|
| 1. Pump rod                    | 3. Tracking knob                |
| 2. Turn this way to track left | 4. Turn this way to track right |

## Adjusting the Parking Brake

Check parking brake for proper adjustment.

1. Disengage brake lever (lever down).
2. Measure the length of the spring. Measurement should be 2-3/4 inch (70 mm) between washers (Fig. 54).
3. If adjustment is necessary, loosen the jam nut below the spring and tighten the nut directly below the yoke (Fig. 54). Turn the nut until the correct measurement is obtained. Tighten the two nuts together and repeat on opposite side of unit.
4. Turn nuts clockwise to shorten spring length and turn counterclockwise to lengthen the spring.
5. Engage parking brake, lever up.
6. Measure the distance between the trunnion roller and the collar on brake rod. Measurement should be 3/16 -1/4 inch (5-7 mm) (Fig. 54).
7. If adjustment is necessary, loosen the jam nut directly below the yoke. Turn the bottom adjusting nuts until the correct measurement is obtained (Fig. 54). Tighten jam nut at yoke

PROTOTYPE

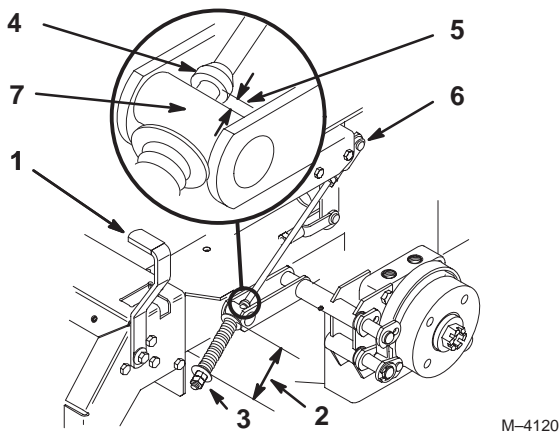

**Figure 54**

- |                              |                             |
|------------------------------|-----------------------------|
| 1. Brake lever               | 5. 3/16 – 1/4 inch (5–7 mm) |
| 2. Spring 2–3/4 inch (70 mm) | 6. Jam nut and yoke         |
| 3. Adjusting nuts            | 7. Trunion                  |
| 4. Collar on brake rod       |                             |

## Servicing the Fuse

### Service Interval/Specification

The electrical system is protected by fuses. It requires no maintenance: however, if a fuse blows check component/circuit for malfunction or short.

Fuse: Main F1—20 amp, blade-type  
 Alternator F2—20 amp, blade-type

1. Raise the seat to gain access to fuse holder (Fig. 55).
2. To replace fuses pull out on the fuse to remove it (Fig. 55).

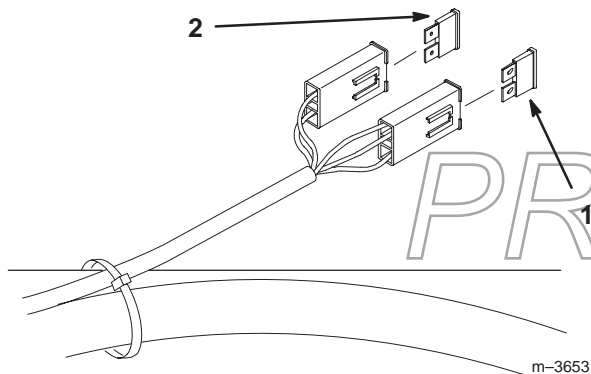

**Figure 55**

- |                |                      |
|----------------|----------------------|
| 1. Main—20 amp | 2. Alternator—20 amp |
|----------------|----------------------|

## Servicing the Battery

⚠
Warning
⚠

Battery posts, terminals, and related accessories contain lead and lead compounds, chemicals known to the State of California to cause cancer and reproductive harm. *Wash hands after handling.*

### Checking Electrolyte Level

1. With the engine off, open the hood to locate the battery.
2. Look at the side of the battery. The electrolyte must be up to the **upper** line (Fig. 56). Do not allow the electrolyte to get below the **lower** line (Fig. 56).
3. If the electrolyte is low, add the required amount of distilled water; refer to Adding Water to the Battery, page 42.

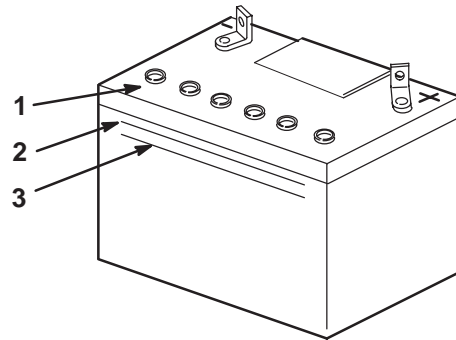

**Figure 56**

- |                |               |
|----------------|---------------|
| 1. Filler caps | 3. Lower line |
| 2. Upper line  |               |

⚠
Danger
⚠

Battery electrolyte contains sulfuric acid which is a deadly poison and causes severe burns.

- Do not drink electrolyte and avoid contact with skin, eyes or clothing. Wear safety glasses to shield your eyes and rubber gloves to protect your hands.
- Fill the battery where clean water is always available for flushing the skin.
- Follow all instructions and comply with all safety messages on the electrolyte container.

## Installing the Battery

1. Position battery in tray with terminal posts toward the engine (Fig. 57).
2. First, install the positive (red) battery cable to positive (+) battery terminal.
3. Then install negative battery cable and ground wire to the negative (-) battery terminal.
4. Secure cables with 2 bolts (1/4 x 3/4 inch), 2 washers (1/4 inch), and 2 locknuts (1/4 inch) (Fig. 57).
5. Slide the red terminal boot onto the positive (red) battery post.
6. Secure battery with J-bolts, hold down clamp and 2 washers (1/4 inch), and 2 wing nuts (1/4 inch) (Fig. 57).

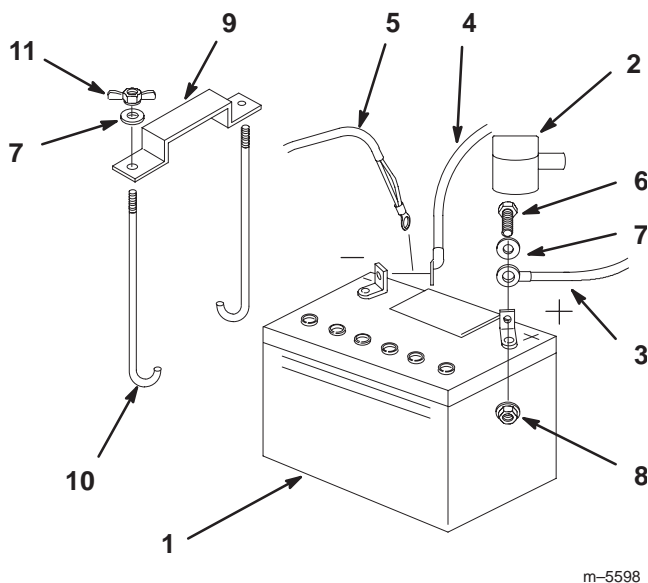

Figure 57

- |                           |                        |
|---------------------------|------------------------|
| 1. Battery                | 7. Washer, 1/4 inch    |
| 2. Terminal boot          | 8. Locknut, 1/4 inch   |
| 3. Positive battery cable | 9. Battery clamp       |
| 4. Negative battery cable | 10. J-bolts            |
| 5. Ground wire            | 11. Wing nut, 1/4 inch |
| 6. Bolt, 1/4 x 3/4 inch   |                        |

## Removing the Battery



### Warning



Battery terminals or metal tools could short against metal machine components causing sparks. Sparks can cause the battery gasses to explode, resulting in personal injury.

- When removing or installing the battery, do not allow the battery terminals to touch any metal parts of the machine.
- Do not allow metal tools to short between the battery terminals and metal parts of the machine.



### Warning



Incorrect battery cable routing could damage the machine and cables causing sparks. Sparks can cause the battery gasses to explode, resulting in personal injury.

- Always *Disconnect* the negative (black) battery cable before disconnecting the positive (red) cable.
- Always *Reconnect* the positive (red) battery cable before reconnecting the negative (black) cable.

1. Disengage the power take off (PTO), set the parking brake, and turn the ignition key to off. Remove the key.
2. Tilt seat up.
3. First disconnect the negative battery cable and ground wire from the negative (-) battery terminal (Fig. 57).
4. Slide the red terminal boot off the positive (red) battery terminal. Then remove positive (red) battery cable (Fig. 57).
5. Remove both wing nuts (1/4 inch) securing the battery clamp (Fig. 57).
6. Remove the battery.

## Adding Water to the Battery

The best time to add distilled water to the battery is just before you operate the machine. This lets the water mix thoroughly with the electrolyte solution.

1. Remove the battery from the machine.
2. Clean the top of the battery with a paper towel.

**Note:** Never fill the battery with distilled water while the battery installed in the machine. Electrolyte could be spilled on other parts and cause corrosion.

3. Remove the vent caps from the battery (Fig. 56).
4. Slowly pour distilled water into each battery cell until the level is up to the **upper** line (Fig. 56) on the battery case.

**Important** Do not overfill the battery because electrolyte (sulfuric acid) can cause severe corrosion and damage to the chassis.

5. Wait five to ten minutes after filling the battery cells. Add distilled water, if necessary, until the electrolyte level is up to the **upper** line (Fig. 56) on the battery case.
6. Reinstall battery vent caps.

## Charging the Battery



### Warning



Charging the battery produces gasses that can explode.

Never smoke near the battery and keep sparks and flames away from battery.

**Important** Always keep the battery fully charged (1.265 specific gravity). This is especially important to prevent battery damage when the temperature is below 32°F (0°C).

1. Remove the battery from the chassis; refer to Removing the Battery, page 42.
2. Check the electrolyte level; refer to Checking Electrolyte Level, page 41.
3. Make sure the filler caps are installed in battery. Charge battery for 10 to 15 minutes at 25 to 30 amps or 30 minutes at 4–6 amps.
4. When the battery is fully charged, unplug the charger from the electrical outlet, then disconnect the charger leads from the battery posts (Fig. 58).

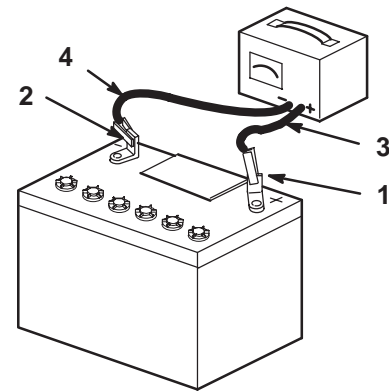

m-4970

**Figure 58**

1. Positive Battery Post
2. Negative Battery Post
3. Red (+) Charger Lead
4. Black (-) Charger Lead

5. Install the battery in the machine and connect the battery cables; refer to Installing the Battery on page 42.

**Note:** Do not run the machine with the battery disconnected, electrical damage may occur.

## Adjusting the Mower Level

1. Position mower on a flat surface. Stop the engine, set the parking brake, remove the key and disconnect the spark plug wire(s) from the spark plug(s).
2. Check tire pressure of all four (4) tires. If needed, adjust to 13 psi (90 kPa)
3. Set anti-scalp rollers to top holes or remove them completely for this adjustment.
4. Raise the deck to the transport position (Fig. 59). Take force off of the two large deck lift springs by loosening jam nut and front spring nut, in front of each spring, as far as possible (Fig. 60).
5. Place two 1-1/4 inch (35 mm) thick blocks under rear left and right lower edge of mower. Place one 1-3/8 inch (44 mm) block under front center lower edge of mower. Not under anti-scalp roller brackets. Lower mower to the 1-1/2 inch (38 mm) height-of-cut position (Fig. 59).

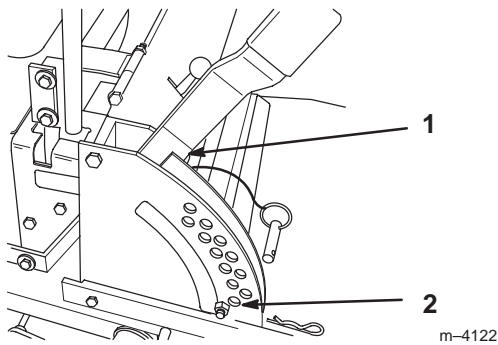

**Figure 59**

- |                       |                                     |
|-----------------------|-------------------------------------|
| 1. Transport position | 2. 1-1/2 inch (38 mm) height-of-cut |
|-----------------------|-------------------------------------|

6. Loosen bottom chain bolt in slot at rear of deck. Repeat for opposite side. (Fig. 60).

**Note:** Do not loosen front chain hardware.

7. Loosen front and rear locking nut on either side of front swivel. Loosen until front chains are loose and deck is supported by blocks. Repeat for opposite side. (Fig. 60).

**Note:** When hardware is loose, deck will rotate the lift handle up out of position.

8. When hardware is loosened, remaining tension in the large support springs will tend to rotate the deck lift handle up, out of the 1-1/2 inch (38 mm) position. Press down on the rear deck support arm to firmly return the deck lift handle to the 1-1/2 inch (38 mm) position (Fig. 60).

**Note:** Do not push on deck lift handle.

9. While continuing to press down on rear deck support arm, take the slack out of the rear chain and tighten hardware at the bottom (Fig. 60). Downward pressure may now be released. Repeat for opposite side.

10. Adjust front swivel using rear locking nut until the front chain is tight and front of deck is still touching block. Tighten front locking nut. Repeat for opposite side.

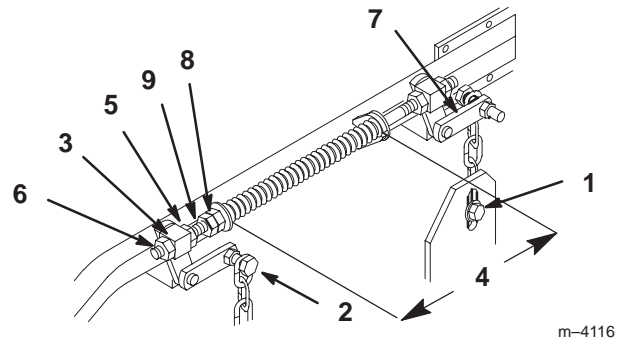

**Figure 60**

- |   |                          |
|---|--------------------------|
| 1. Bottom chain bolt                      | 5. Rear locking nut      |
| 2. Top chain bolt                         | 6. Front locking nut     |
| 3. Front swivel                           | 7. Rear deck support arm |
| 4. 10-1/4 inch (260 mm) spring compressed | 8. Front spring nut      |
|   | 9. Jam nut               |

11. Recheck that blocks fit just snugly under the mower and that tension on all four chains are approximately equal.

12. Raise deck to 3 inch (76 mm) height of cut and measure actual height from blade tips to ground. Height of cut for the front blade tips should be 3 inch ± 1/8 inch (76 mm ± 3 mm). Height of cut for rear blade tips should be 3-1/4 inch ± 1/8 inch (83 mm ± 3 mm). Readjust if needed.

**Note:** When checking blade tip heights make sure blades are not bent and check blade pointing front to rear.

13. Install anti-scalp rollers for proper height-of-cut and tighten securely. See Adjusting Anti Scalp Rollers on page 22.

14. Raise deck lift lever to the transport position (Fig. 59).

15. Adjust compression springs by turning the front spring nuts so the distance between the two large washers is 10-1/4 inch (260 mm). Then tighten jam nut (Fig. 60).

**Note:** Make sure all hardware is tight.

## Cleaning Under the Deck

Remove grass build up under deck daily.

1. Position mower on a flat surface. Stop the engine, set the parking brake, remove the key and disconnect the spark plug wire(s) from the spark plug(s).
2. Raise deck to the transport position.
3. Lift the front of unit and support unit using jack stands.

**Danger**

**Mechanical or hydraulic jacks may fail to support machine and cause a serious injury.**

- Use jack stand when supporting machine.
- Do not use hydraulic jacks.

## Adjusting the Push Arms

1. To adjust push arms, loosen jam nut and rotate ball joint counterclockwise, one turn at a time. (Fig. 61).
2. Adjust each side the same amount. Each push arm should have a nominal length of 15-5/16 inch (389mm) (Fig. 61).

**Note:** Increase tension by lengthening the push arms and decrease tension by shortening push arms.

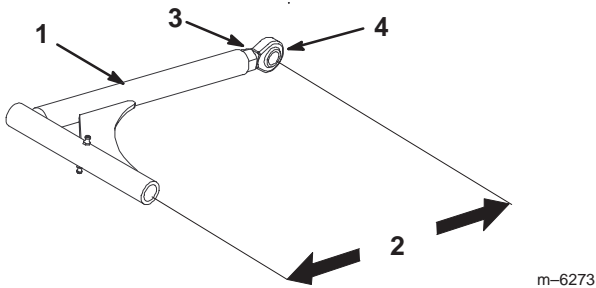

**Figure 61**

- |                                  |               |
|----------------------------------|---------------|
| 1. Push arm                      | 3. Jam nut    |
| 2. 15-5/16 inch (389 mm) nominal | 4. Ball joint |

## Inspecting the Belts

Inspect all belts every 100 hours.

1. Check belts for cracks, frayed edges, burn marks or any other damage. Replace damaged belts.

## Replacing the Deck Belt

Squealing when the belt is rotating, blades slipping when cutting grass, frayed belt edges, burn marks and cracks are signs of a worn deck belt. Replace the deck belt if any of these conditions are evident.

1. Stop the engine, set the parking brake, remove the key and disconnect the spark plug wire(s) from the spark plug(s).
2. Remove belt covers over outside spindles.
3. Loosen outer nut on spring eye bolt (Fig. 62).

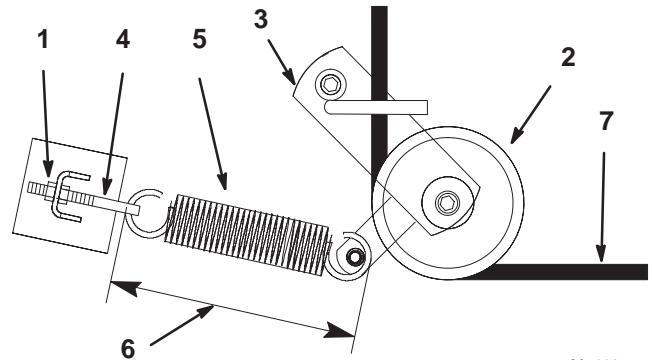

**Figure 62**

Top View

- |                    |                                      |
|--------------------|--------------------------------------|
| 1. Outer nut       | 5. Spring                            |
| 2. Idler pulley    | 6. 9-3/8 inch ± 1/8 inch (238±.3 mm) |
| 3. Idler arm       | 7. Deck belt                         |
| 4. Spring eye bolt |                                      |

4. Remove belt. Start at outside pulley and rotate off (Fig. 63).

**Note:** Do not remove spring.

**Caution**

**Spring is under tension when installed and can cause personal injury.**

**Do not remove spring from spring eye bolt.**

5. Remove spring loaded idler pulley (Fig. 62).
6. Route new belt through idler arm (Fig. 62).
7. Reinstall idler pulley and route belt onto other pulleys (Fig. 63).

8. Retighten outer nut on spring eye bolt (Fig. 62).

**Note:** Check spring length. The spring should measure 9-3/8 inch ± 1/8 inch (238 mm ± 3 mm) when installed. Adjust if it does not (Fig. 62).

9. Install belt covers over outside spindles.

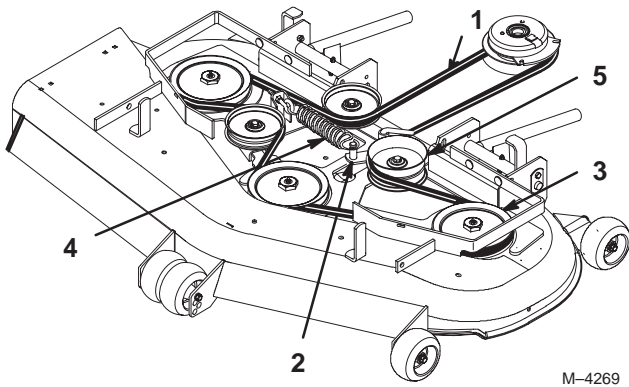

**Figure 63**

Top View

- |                   |                 |
|-------------------|-----------------|
| 1. Deck belt      | 4. Spring       |
| 2. Idler arm      | 5. Idler pulley |
| 3. Outside pulley |                 |

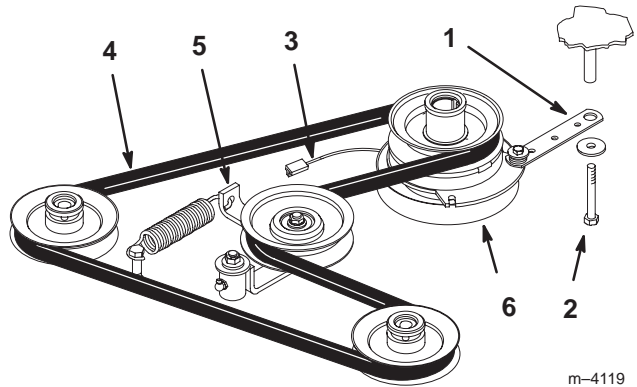

**Figure 64**

- |                           |           |
|---------------------------|-----------|
| 1. Clutch strap           | 4. Belt   |
| 2. Bolt                   | 5. Idler  |
| 3. Clutch electrical wire | 6. Clutch |

## Replacing the Pump Drive Belt

Check pump drive belt for wear after every 50 hours of operation.

1. Remove deck belt first. See Replacing the Deck Belt on page 45.
2. Remove bolt from clutch strap and unplug clutch electrical wire (Fig. 64).
3. Pull spring loaded idler to side. Remove traction belt from the engine and hydro pump pulleys (Fig. 64).
4. Install new belt around engine and hydro pump pulleys (Fig. 64).
5. Pull spring loaded idler to side and align belt. Release pressure on spring loaded idler (Fig. 64).
6. Reinstall deck belt.

## Replacing the Grass Deflector

**Warning**

**An uncovered discharge opening could allow the lawn mower to throw objects in the operator's or bystander's direction and result in serious injury. Also, contact with the blade could occur.**

**Never operate the lawn mower unless you install a cover plate, a mulch plate, or a grass chute and catcher.**

1. Remove the locknut, bolt, spring and spacer holding the deflector to the pivot brackets (Fig. 65). Remove damaged or worn grass deflector.
2. Place spacer and spring onto grass deflector. Place the straight end of spring behind deck edge.

**Note:** Make sure the straight end of spring is installed behind deck edge before installing the bolt as shown in figure 65.

3. Install bolt and nut. Place hook end of spring around grass deflector (Fig. 65).

**Important** The grass deflector must be able to lower down into position. Lift the deflector up to test that it lowers into the full down position.

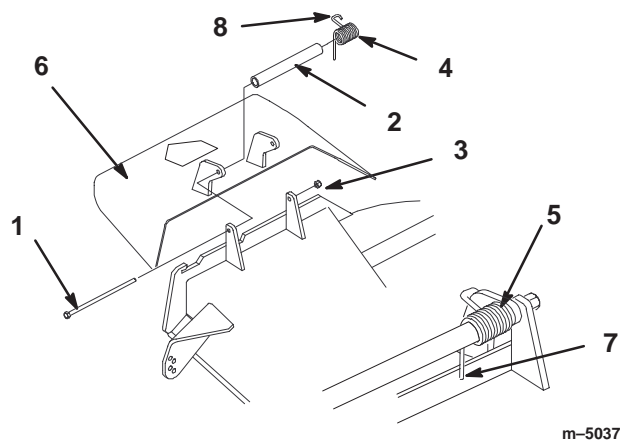

Figure 65

- |                     |  |
|---------------------|--|
| 1. Bolt             | 6. Grass Deflector                               |
| 2. Spacer           | 7. Place behind deck edge before installing bolt |
| 3. Locknut          | 8. Hook end of spring                            |
| 4. Spring           |  |
| 5. Spring installed |  |

## Waste Disposal

Engine oil, hydraulic oil and engine coolant are pollutants to the environment. Dispose of these according to your state and local regulations.

## Mercury Tilt Switch

The tilt switch on this unit is located under the seat. Tilt seat up to gain access.

The tilt switch on this unit contains mercury, a hazardous material. Mercury that is outside a sealed container vaporizes at room temperature. The vapors are harmful. Mercury can be absorbed through the skin. Do not attempt to open or repair this switch.

A very small amount of mercury is contained in a hermetically sealed body. The steel switch is then potted in a hard epoxy in a plastic case. It is unlikely that the mercury will ever escape from the enclosure. These high performance and reliable inexpensive switches are recyclable.

Mercury is an important and beneficial compound but requires special care in handling and disposal. When used and managed properly, mercury is not a threat to people or the environment. This information is presented to users so that they are aware that these switches contain mercury and will apply sound disposal practices when these devices reach their normal end of life or are damaged.

## Mercury Tilt Switch Disposal

Several states have passed laws concerning the disposal of devices containing mercury. In all the remaining states it is advisable to follow similar procedures. The laws state that these sealed devices contain mercury and should not be placed in the garbage until the mercury is removed and reused, recycled or otherwise managed to insure that it does not become part of solid waste or waters. Management and disposal practices must be within relevant federal, state or local laws.

Return the switch to your Toro dealer if it is faulty and is being replaced or if the unit containing the switch is no longer operating and is being scrapped. If the switch is damaged or broken open use extreme caution in handling. Call your local waste management authority or Toro Customer Service for instructions.

⚠
Caution
⚠

**The mercury contained in the tilt switch is poisonous and exposure to mercury can cause severe illness.**

- **Never attempt to open or repair the tilt switch.**
- **Avoid contact with the mercury.**

PROTOTYPE

# Wiring Diagram

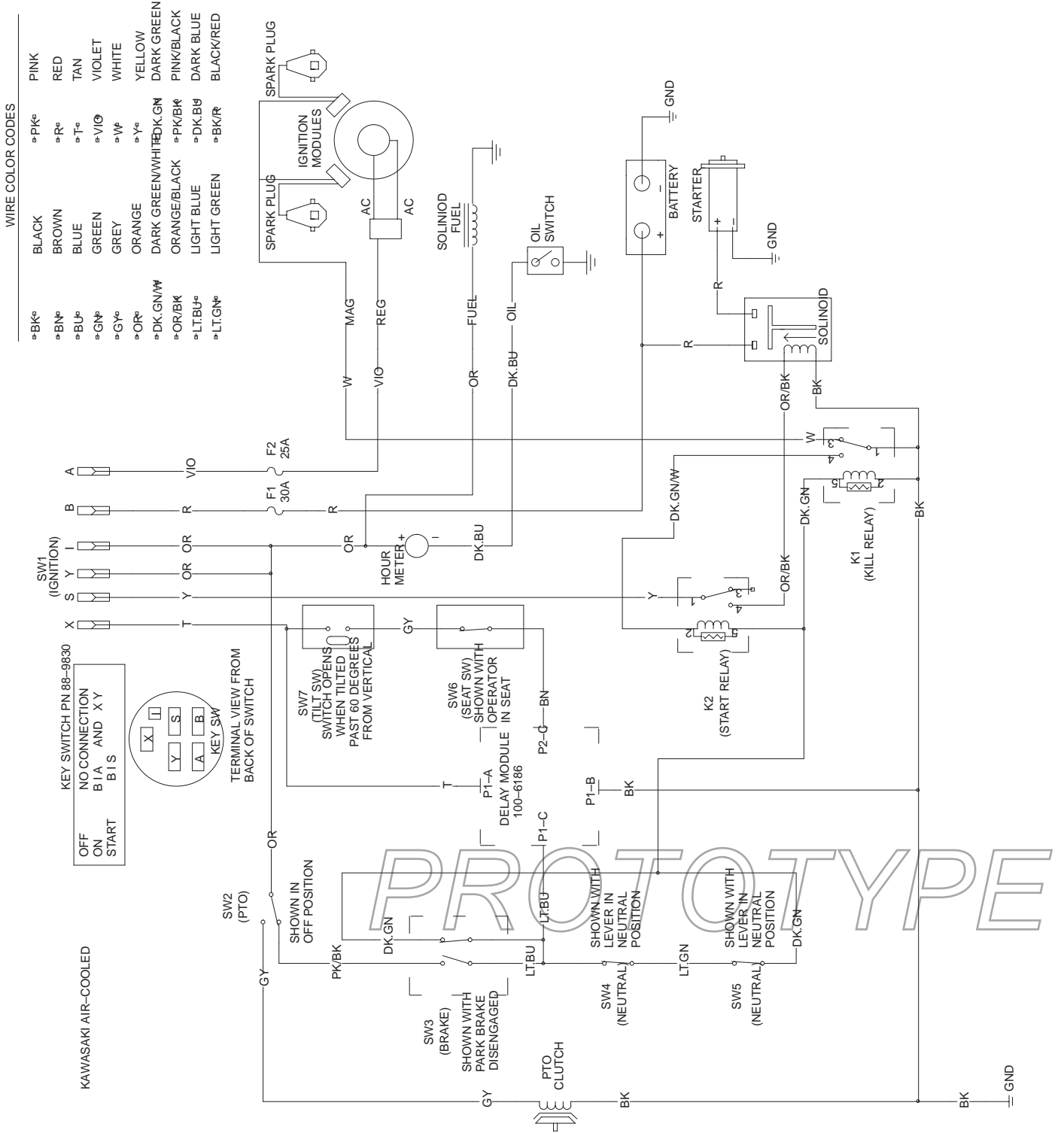

## Cleaning and Storage

1. Disengage the power take off (PTO), set the parking brake and turn the ignition key to off. Remove spark plug wire. Remove the key.
2. Remove grass clippings, dirt, and grime from the external parts of the entire machine, especially the engine and hydraulic system. Clean dirt and chaff from the outside of the engine's cylinder head fins and blower housing.

**Important** You can wash the machine with mild detergent and water. Do not pressure wash the machine. Avoid excessive use of water, especially near the control panel, engine, hydraulic pumps and motors.

3. Service the air cleaner; refer to Servicing the Air Cleaner, page 29.
4. Grease and oil the machine; refer to Greasing and Lubrication, page 33.
5. Change the crankcase oil and filter; refer to Servicing the Engine Oil, page 30.
6. Change the hydraulic filter; refer to Servicing the Hydraulic System, page 35.
7. Check the tire pressure; refer to Checking the Tire Pressure, page 34.
8. Charge the battery; refer to Servicing the Battery page 41.
9. Scrape any heavy buildup of grass and dirt from the underside of the mower, then wash the mower with a garden hose.
10. Check the condition of the blades. Refer to Servicing the Cutting Blades on page 27.
11. Prepare the machine for storage when non-use occurs over 30 days. Prepare machine for storage as follows.

- A. Add a petroleum based stabilizer/conditioner to fuel in the tank. Follow mixing instructions from stabilizer manufacture. **Do not use an alcohol based stabilizer (ethanol or methanol).**

**Note:** A fuel stabilizer/conditioner is most effective when mixed with fresh gasoline and used at all times.

- B. Run engine to distribute conditioned fuel through the fuel system (5 minutes).
- C. Stop engine, allow to cool and drain the fuel tank; refer to Servicing the Fuel Tank, page 32.
- D. Restart engine and run it until it stops.
- E. Choke or prime the engine. Start and run engine until it will not start. Operate primer, if equipped on machine, several times to ensure fuel remains in primer system.
- F. Dispose of fuel properly. Recycle as per local codes.

**Important** Do not store stabilizer/conditioned gasoline over 90 days.

12. Remove the spark plug(s) and check its condition; refer to Servicing the Spark Plug, page 31. With the spark plug(s) removed from the engine, pour two tablespoons of engine oil into the spark plug hole. Now use the starter to crank the engine and distribute the oil inside the cylinder. Install the spark plug(s). Do not install the wire on the spark plug(s).
13. Check and tighten all bolts, nuts, and screws. Repair or replace any part that is damaged or defective.
14. Paint all scratched or bare metal surfaces. Paint is available from your Authorized Service Dealer.
15. Store the machine in a clean, dry garage or storage area. Remove the key from the ignition switch and keep it in a memorable place out of reach of children or other unauthorized users. Cover the machine to protect it and keep it clean.

PROTOTYPE

# Troubleshooting

Problem	Possible Causes	Corrective Action
Starter does not crank	<ol style="list-style-type: none"> <li>1. Blade control (PTO) is engaged.</li> <li>2. Parking brake is not on.</li> <li>3. Operator is not seated.</li> <li>4. Battery is dead.</li> <li>5. Electrical connections are corroded or loose.</li> <li>6. Fuse is blown.</li> <li>7. Relay or switch is defective.</li> </ol>	<ol style="list-style-type: none"> <li>1. Move blade control (PTO) to disengage.</li> <li>2. Set parking brake.</li> <li>3. Sit on the seat.</li> <li>4. Charge the battery.</li> <li>5. Check electrical connections for good contact.</li> <li>6. Replace fuse.</li> <li>7. Contact Authorized Service Dealer.</li> </ol>
Engine will not start, starts hard, or fails to keep running.	<ol style="list-style-type: none"> <li>1. Fuel tank is empty.</li> <li>2. Fuel valve turned off.</li> <li>3. Choke is not on.</li> <li>4. Air cleaner is dirty.</li> <li>5. Spark plug wires are loose or disconnected.</li> <li>6. Spark plugs are pitted, fouled, or gap is incorrect.</li> <li>7. Dirt in fuel filter.</li> <li>8. Dirt, water, or stale fuel is in fuel system.</li> </ol>	<ol style="list-style-type: none"> <li>1. Fill fuel tank with gasoline.</li> <li>2. Open fuel valve.</li> <li>3. Move choke lever to on.</li> <li>4. Clean or replace air cleaner element.</li> <li>5. Install wires on spark plug.</li> <li>6. Install new, correctly gapped spark plugs.</li> <li>7. Replace fuel filter.</li> <li>8. Contact Authorized Service Dealer.</li> </ol>
Engine loses power.	<ol style="list-style-type: none"> <li>1. Engine load is excessive.</li> <li>2. Air cleaner is dirty.</li> <li>3. Oil level in crankcase is low.</li> <li>4. Cooling fins and air passages under engine blower housing are plugged.</li> <li>5. Spark plugs are pitted, fouled, or gap is incorrect.</li> <li>6. Vent in fuel cap is closed.</li> <li>7. Dirt in fuel filter.</li> <li>8. Dirt, water, or stale fuel is in fuel system.</li> </ol>	<ol style="list-style-type: none"> <li>1. Reduce ground speed.</li> <li>2. Clean air cleaner element.</li> <li>3. Add oil to crankcase.</li> <li>4. Remove obstruction from cooling fins and air passages.</li> <li>5. Install new, correctly gapped spark plugs.</li> <li>6. Open vent in fuel cap.</li> <li>7. Replace fuel filter.</li> <li>8. Contact Authorized Service Dealer.</li> </ol>
Engine overheats.	<ol style="list-style-type: none"> <li>1. Engine load is excessive.</li> <li>2. Oil level in crankcase is low.</li> <li>3. Cooling fins and air passages under engine blower housing are plugged.</li> </ol>	<ol style="list-style-type: none"> <li>1. Reduce ground speed.</li> <li>2. Add oil to crankcase.</li> <li>3. Remove obstruction from cooling fins and air passages.</li> </ol>

<b>Problem</b>	<b>Possible Causes</b>	<b>Corrective Action</b>
Abnormal vibration.	<ol style="list-style-type: none"> <li>1. Engine mounting bolts are loose.</li> <li>2. Loose engine pulley, idler pulley, or blade pulley.</li> <li>3. Engine pulley is damaged.</li> </ol>	<ol style="list-style-type: none"> <li>1. Tighten engine mounting bolts.</li> <li>2. Tighten the appropriate pulley.</li> <li>3. Contact Authorized Service Dealer.</li> </ol>
Machine does not drive.	<ol style="list-style-type: none"> <li>1. Traction belt is worn, loose or broken.</li> <li>2. Traction belt is off pulley.</li> <li>3. Hydro fluid level low.</li> </ol>	<ol style="list-style-type: none"> <li>1. Contact Authorized Service Dealer.</li> <li>2. Contact Authorized Service Dealer.</li> <li>3. Add hydro fluid to reservoir.</li> </ol>
Abnormal vibration.	<ol style="list-style-type: none"> <li>1. Engine mounting bolts are loose.</li> <li>2. Loose engine pulley, idler pulley, or blade pulley.</li> <li>3. Engine pulley is damaged.</li> <li>4. Cutting blade(s) is/are bent or unbalanced.</li> <li>5. Blade mounting bolt is loose.</li> <li>6. Engine mounting bolts are loose.</li> <li>7. Loose engine pulley, idler pulley, or blade pulley.</li> <li>8. Engine pulley is damaged.</li> <li>9. Blade spindle bent.</li> </ol>	<ol style="list-style-type: none"> <li>1. Tighten engine mounting bolts.</li> <li>2. Tighten the appropriate pulley.</li> <li>3. Contact Authorized Service Dealer.</li> <li>4. Install new cutting blade(s).</li> <li>5. Tighten blade mounting bolt.</li> <li>6. Tighten engine mounting bolts.</li> <li>7. Tighten the appropriate pulley.</li> <li>8. Contact Authorized Service Dealer.</li> <li>9. Contact Authorized Service Dealer.</li> </ol>
Uneven cutting height.	<ol style="list-style-type: none"> <li>1. Blade(s) not sharp.</li> <li>2. Cutting blade(s) is/are bent.</li> <li>3. Mower is not level.</li> <li>4. Gage wheel not set correctly.</li> <li>5. Underside of mower is dirty.</li> <li>6. Tire pressure is incorrect.</li> <li>7. Blade spindle bent.</li> </ol>	<ol style="list-style-type: none"> <li>1. Sharpen blade(s).</li> <li>2. Install new cutting blade(s).</li> <li>3. Level mower from side-to-side and front-to-rear.</li> <li>4. Adjust gage wheel height.</li> <li>5. Clean the underside of the mower.</li> <li>6. Adjust tire pressure.</li> <li>7. Contact Authorized Service Dealer.</li> </ol>

<b>Problem</b>	<b>Possible Causes</b>	<b>Corrective Action</b>
Blades do not rotate.	<ol style="list-style-type: none"><li>1. Drive belt is worn, loose or broken.</li><li>2. Drive belt is off pulley.</li><li>3. Deck belt is worn, loose or broken.</li></ol>	<ol style="list-style-type: none"><li>1. Install new drive belt.</li><li>2. Install drive belt and check adjusting shafts and belt guides for correct position.</li><li>3. Install new deck belt.</li></ol>

*PROTOTYPE*

*PROTOTYPE*

*PROTOTYPE*

*PROTOTYPE*



LCE

# The Toro Total Coverage Guarantee

## A Limited Warranty

### Conditions and Products Covered

The Toro Company and its affiliate, Toro Warranty Company, pursuant to an agreement between them, jointly promise to repair the listed Toro Products if defective in materials or workmanship. The following time periods apply from the date of purchase:

<u>Products</u>	<u>Warranty Period</u>
• All Products	1 year
• All Spindles	2 years parts and labor; third year, parts only
• Engines/Hydraulic Systems* on the following: Outfront and Mid-Mount Z's ProLine Mid-Size Mowers Groundsmaster® Riding Mowers Backpack Blowers	2 years
• Deck Shells (36"–72") on the following: ProLine Mid-Size Mowers Mid-Mount Z's	2 years
• Electric Clutch on 200 Series Mid-Mount Z's	2 years

This warranty includes the cost of parts and labor, but you must pay transportation costs.

This warranty applies to:

- Outfront and Mid-Mount Z's
- ProLine Mid-Size Mowers
- Groundsmaster Riding Mowers
- Turf Maintenance Equipment
- Debris Management Equipment

\* Some engines used on Toro LCE Products are warranted by the engine manufacturer.

### Instructions for Obtaining Warranty Service

If you think that your Toro Product contains a defect in materials or workmanship, follow this procedure:

1. Contact any Toro Authorized or Master Service Dealer to arrange service at their dealership. To locate a dealer convenient to you, access our website at [www.Toro.com](http://www.Toro.com). U.S. Customers may also call 800-348-2424.
2. Bring the product and your proof of purchase (sales receipt) to the Service Dealer.

If for any reason you are dissatisfied with the Service Dealer's analysis or with the assistance provided, contact us at:

LCB Customer Service Department  
Toro Warranty Company  
8111 Lyndale Avenue South  
Bloomington, MN 55420-1196  
888-577-7466 (U.S. customers)  
877-484-9255 (Canada customers)

### Countries Other than the United States or Canada

Customers who have purchased Toro products exported from the United States or Canada should contact their Toro Distributor (Dealer) to obtain guarantee policies for your country, province, or state. If for any reason you are dissatisfied with your Distributor's service or have difficulty obtaining guarantee information, contact the Toro importer. If all other remedies fail, you may contact us at Toro Warranty Company.

### Owner Responsibilities

You must maintain your Toro Product by following the maintenance procedures described in the operator's manual. Such routine maintenance, whether performed by a dealer or by you, is at your expense.

### Items and Conditions Not Covered

There is no other express warranty except for special emission system coverage on some products. This express warranty does not cover the following:

- Cost of regular maintenance service or parts, such as filters, fuel, lubricants, tune-up parts, blade sharpening, brake and clutch adjustments.
- Any product or part which has been altered or misused or required replacement or repair due to normal wear, accidents, or lack of proper maintenance.
- Repairs necessary due to improper fuel, contaminants in the fuel system, or failure to properly prepare the fuel system prior to any period of non-use over three months.
- Pickup and delivery charges.

All repairs covered by this warranty must be performed by an Authorized Toro Service Dealer using Toro approved replacement parts.

### General Conditions

Repair by an Authorized Toro Service Dealer is your sole remedy under this warranty.

Neither The Toro Company nor Toro Warranty Company is liable for indirect, incidental or consequential damages in connection with the use of the Toro Products covered by this warranty, including any cost or expense of providing substitute equipment or service during reasonable periods of malfunction or non-use pending completion of repairs under this warranty.

Some states do not allow exclusions of incidental or consequential damages, or limitations on how long an implied warranty lasts, so the above exclusions and limitations may not apply to you.

All implied warranties of merchantability (that the product is fit for ordinary use) and fitness for use (that the product is fit for a particular purpose) are limited to the duration of the express warranty.

This warranty gives you specific legal rights, and you may also have other rights which vary from state to state.

