



## Z257

### Z Master<sup>®</sup> with 52in SFS Side Discharge Mower

Model No. 74230—230000001 and Up

## Parts Catalog

---

### Ordering Replacement Parts

To order replacement parts, please supply: the part number, the quantity, and the description of each part desired.

### Understanding Reference Numbers

Each identified part in an illustration has a reference number. The reference number for a part also appears in the parts list, along with other information about the part.

This catalog uses two special reference number formats, one to indicate parts in a service assembly and another to indicate the quantity of a given part in an illustration.

### Service Assembly Reference Numbers

Parts in service assemblies have reference numbers in the form **a:b**. The **a** represents the reference number of the entire service assembly and the **b** represents a sequential number unique to each part within the service assembly.

For example, a wheel assembly might be identified by reference number **6**, the tire by **6:1**, the valve by **6:2**, and the wheel by **6:3**. When you order the assembly identified by reference number **6**, you receive all parts identified by reference numbers **6:1**, **6:2**, and **6:3**. However, you may also order any part individually.

Reference numbers of this type appear in illustrations and in part lists.

### Reference Numbers Indicating Quantity

In an illustration, if a reference number indicates more than one part, the reference number has the form **nX y**. The **n** represents the quantity of the part, the **X** is the multiplication symbol, and the **y** represents the reference number.

For example, in an illustration, the reference number **2X 37** means that two of the parts identified by reference number **37** are indicated.

## Contents

<b>Description</b>	<b>Page</b>	<b>Description</b>	<b>Page</b>
Front Frame Assembly .....	3	Stand Assembly .....	13
Caster and Wheel Assembly .....	4	Engine and Clutch Assembly .....	14
Main Frame Assembly .....	5	Guard Assembly .....	15
Brake and Wheel Hub Assembly .....	6	Fuel System Assembly .....	16
Steering Control Assembly .....	7	Electrical System Assembly .....	17
Hydraulic System Assembly .....	8	Deck, Deflector and Roller Assembly .....	18
Seat Assembly .....	10	Spindle and Pulley Assembly .....	19
Deck Connection Assembly .....	11	Belt and Idler Arm Assembly .....	20
Drive Idler Assembly .....	12	Electrical Schematic .....	21

## Accessories

<b>Description</b>	<b>Model / Part No.</b>	<b>Description</b>	<b>Model / Part No.</b>
Suspension Seat Kit .....	99-8522	Hitch Kit .....	99-8925
Atomic Blade Assembly .....	104-1303	Spark Arrestor Kit .....	105-1672
Striping Kit .....	30163	Filter Minder .....	99-4664
Recycler Kit .....	100-9600		

## Part Description Abbreviations

Part descriptions in this catalog may include the following abbreviations.

<b>Abbreviation</b>	<b>Meaning</b>	<b>Abbreviation</b>	<b>Meaning</b>
AR .....	as required	HYD .....	hydraulic
ASM .....	assembly	INC .....	incorporated
CARR .....	carriage	LH .....	left hand
DEG .....	degrees	NI .....	nylon insert
FH .....	flat head	PPH .....	Phillips pan head
GA .....	gauge	PTH .....	Phillips truss head
HF .....	hex flange	PTO .....	power take off
HH .....	hex head	RH .....	right hand
HHF .....	hex head flange	SFH .....	slotted fillister head
HLH .....	hex lag head	SHH .....	slotted hex head
HJ .....	hex jam	SQH .....	square head
HOC .....	height-of-cut	SHWH .....	slotted hex washer head
HS .....	hex socket	SPH .....	slotted pan head
HSBH .....	hex socket button head	SRH .....	slotted round head
HSFH .....	hex socket flat head	STD .....	standard
HSH .....	hex socket head	TAP .....	self tapping
HWH .....	hex washer head	TTH .....	Torx truss head
HWHTF .....	hex washer head thread forming	WH .....	wing head

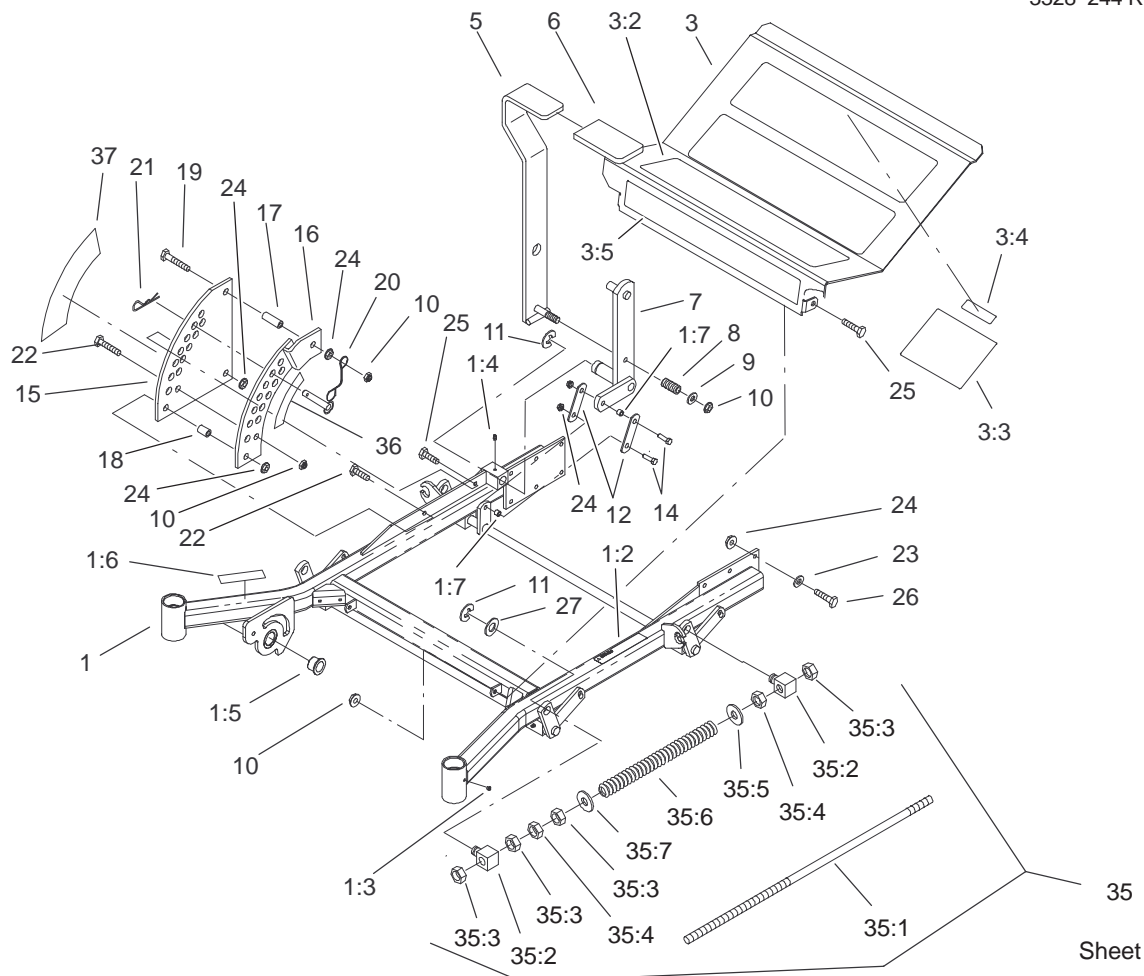

Sheet No.: 2

## Front Frame Assembly

Ref. No.	Part No.	Qty.	Description
1	104-5131	1	Frame ASM
1:2	1-633818	1	Decal-Warning
1:3	1-811010	2	Plug
1:4	302-19	5	Fitting-Grease
1:5	94-1291	2	Bushing-Special
1:6	104-7759	1	Decal-Warning
1:7	103-1918	1	Bushing
3	100-6509	1	Floorpan ASM
3:2	1-633553	3	Pad-Antiskid
3:3	1-633766	1	Decal-Check
3:4	98-5954	1	Decal-Missing, Cover
3:5	1-633737	1	Decal-Z Master
5	103-2083-03	1	Lever-Lift
6	1-633295	1	Grip-Lever, Lift
7	103-2064-03	1	Arm-Lift, Deck
8	1-633325	1	Spring-Compression
9	3256-24	1	Washer-Flat
10	3296-39	5	Nut-Lock, NI
11	32151-103	5	Ring-Snap
12	1-633068	2	Arm-Lift, Deck
14	323-29	2	Screw-HH
15	1-633889-01	1	Plate-Lift, Deck
16	1-632899-01	1	Plate-Lift, Deck
17	1-633082	1	Bushing-Lever, Lift
18	1-633080	1	Bushing-Lever, Lift
19	323-13	1	Screw-HH

Ref. No.	Part No.	Qty.	Description
20	1-633097	1	Pin-Hitch W/Lanyard
21	1-806005	1	Pin-Hair
22	323-9	2	Screw-HH
23	98-5975	12	Washer-Belleville
24	3290-357	17	Nut-HHF
25	323-6	3	Screw-HH
26	323-7	12	Screw-HH
27	3256-29	4	Washer-Flat
☆35		2	Spring ASM
35:1	1-633096	1	Rod-Lift, Deck
35:2	1-633441	2	Swivel-Deck Mount, Rear
35:3	3217-11	4	Nut-Hex
35:4	3218-6	2	Nut-Jam
35:5	3256-7	1	Washer-Flat
35:6	1-653009	1	Spring-Compression
35:7	3256-27	1	Washer-Flat
36	1-633706	1	Decal-Height, Deck
37	1-633345	1	Decal-Height, Deck

☆ Not serviced separately



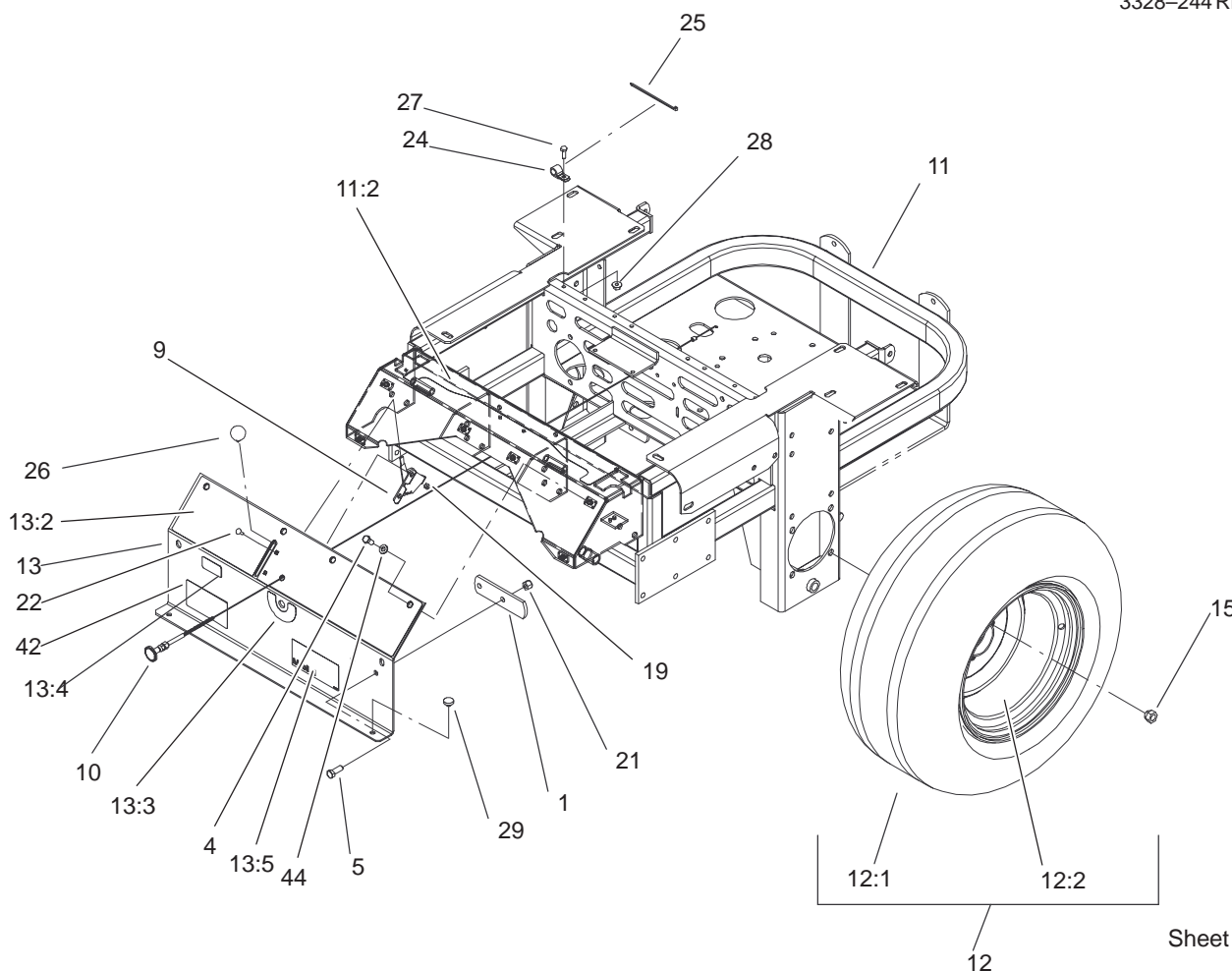

Sheet No.: 4

## Main Frame Assembly

Ref. No.	Part No.	Qty.	Description	Ref. No.	Part No.	Qty.	Description
1	1-633964-03	1	Stop-Brake, Park	42	106-6561	1	Decal-Z257
4	322-3	6	Screw-HH	44	3256-23	6	Washer-Flat
5	323-6	2	Screw-HH				
9	1-633696	1	Cable-Throttle				
10	1-603336	1	Control-Choke				
11	105-3648	1	Main Frame ASM				
11:2	103-2433	1	Decal-Console, Top				
12	1-653010	2	Wheel And Tire ASM				
12:1	1-653160	1	Tire				
12:2	1-653158	1	Wheel				
13	99-4623	1	Console ASM				
13:2	100-4311	1	Decal-Panel, Control				
13:3	103-0262	1	Decal-Valve, Fuel				
13:4	98-4387	1	Decal-Protection, Ear				
13:5	104-8172	1	Decal-Mobil 1				
15	242-50	8	Nut-Lug				
19	3296-2	2	Nut-Lock				
21	3296-39	2	Nut-Lock, NI				
22	1-807513	2	Bolt-CARR				
24	1-513762	1	Clip-Loom				
25	1-303335	1	Tie-Plastic				
26	1-513592	1	Knob-Ball				
27	321-4	1	Screw-HH				
28	32128-33	1	Nut-HF				
29	1-513658	2	Bumper-Catcher, Grass				

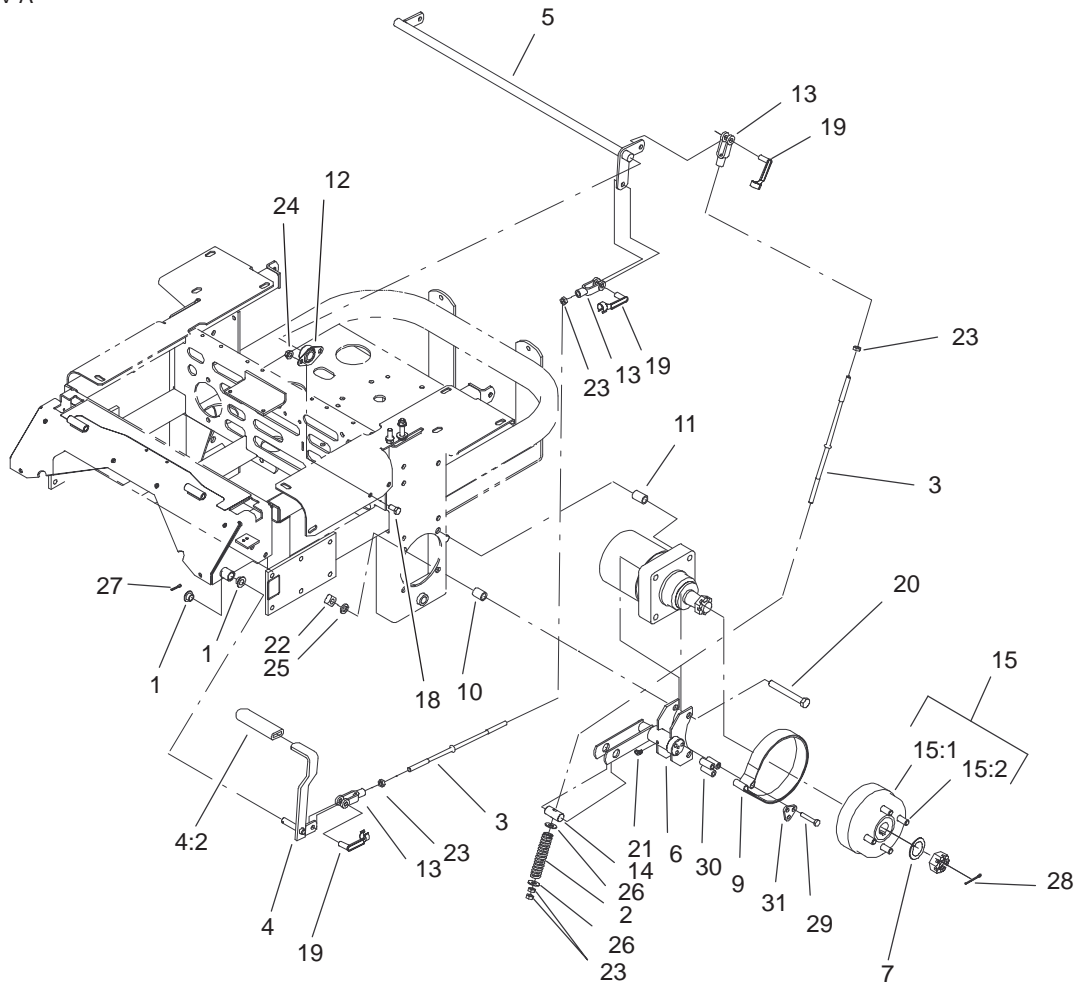

Sheet No.: 5

## Brake and Wheel Hub Assembly

Ref. No.	Part No.	Qty.	Description
1	1-513140	2	Bearing-Control
2	1-633454	2	Spring-Brake
3	1-633477	3	Rod-Brake
4	1-634500	1	Brake Lever ASM
4:2	1-633268	1	Grip-Lever, Brake
5	1-632217-03	1	Shaft-Brake
6	103-0352-03	2	Bracket-Brake
7	1-523157	2	Washer-Spacer
9	103-0355	2	Band-Brake
10	1-633380	4	Spacer-Wheel, Short
11	1-633382	4	Spacer-Wheel, Long
12	1-633102	2	Bearing-Flange, Side
13	1-633131	4	Yoke-Linkage, Brake
14	1-633144	2	Pin-Trunion
15	103-0590	2	Hub-Wheel
15:1	103-0589	1	Hub-Wheel
15:2	1-633926	4	Stud-Wheel
18	323-4	4	Screw-HH
19	103-2399	4	Pin-Spring, Clevis
20	325-17	8	Screw-HH
21	1481	2	Fitting-Grease
22	103-0131	8	Nut-Square
23	3219-3	8	Nut-HH
24	3290-357	4	Nut-HHF
25	3253-7	8	Washer-Lock
26	3256-4	4	Washer-Flat

Ref. No.	Part No.	Qty.	Description
27	3272-10	1	Pin-Cotter
28	1-806800	2	Pin-Cotter
29	322-9	6	Screw-HH
30	103-0384	6	Spacer
31	103-0374	2	Retainer-Band, Brake

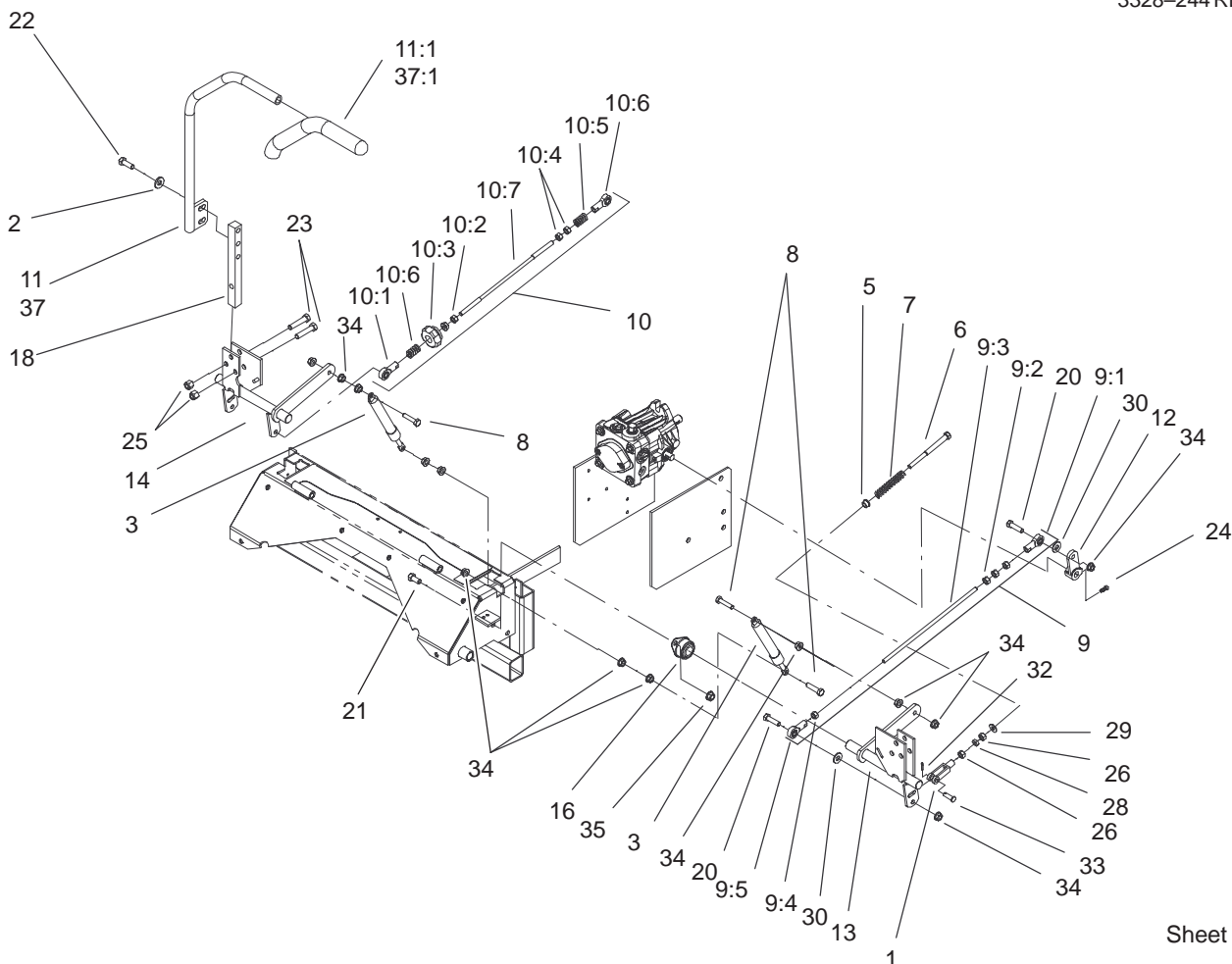

Sheet No.: 6

## Steering Control Assembly

Ref. No.	Part No.	Qty.	Description
1	1-303105	2	Yoke-Adjustable
2	98-5975	4	Washer-Belleville
3	103-2913	2	Damper-Control, Motion
5	1-603735	2	Bushing-Flanged
6	1-603737	2	Bolt-Return, Neutral
7	1-603807	2	Spring-Return, Neutral
8	1-403180	4	Screw-HH
9	1-634275	1	LH Pump Linkage ASM
9:1	1-543017	1	Balljoint-RH
9:2	3219-2	3	Nut-Hex
9:3	1-633153	1	Link-Rod, Tracking
9:4	1-804524	1	Nut
9:5	1-633152	1	Balljoint-Thread, LH
10	103-3061	1	Tracking Rod ASM
10:1	1-543017	1	Balljoint-RH
10:2	3219-2	1	Nut-Hex
10:3	103-3060	1	Knob-Tracking
10:4	1-804524	2	Nut
10:5	1-323245	2	Spring-Compression
10:6	1-633152	1	Balljoint-Thread, LH
10:7	103-3064	1	Link-Rod, Tracking
11	103-0632	1	RH Lever ASM
11:1	1-633257	1	Grip-Control, Motion

Ref. No.	Part No.	Qty.	Description
12	1-632208	2	Arm-Control, Pump
13	1-642319	1	Control-Motion, LH
14	1-642320	1	Control-Motion, RH
16	1-633102	4	Bearing-Flange, Side
18	103-0407	2	Arm-Shaft, Control
20	322-6	4	Screw-HH
21	323-4	8	Screw-HH
22	323-6	4	Screw-HH
23	323-9	6	Screw-HH
24	1-803022	2	Screw-Set
25	3296-39	6	Nut-Lock, NI
26	3219-2	4	Nut-Hex
28	3220-2	2	Nut
29	3256-2	2	Washer-Flat
30	3256-3	4	Washer-Flat
32	3272-5	2	Pin-Cotter
33	1-808280	2	Pin-Clevis
34	32128-20	16	Nut-HF
35	3290-357	8	Nut-HHF
37	103-0631	1	LH Lever ASM
37:1	1-633257	1	Grip-Control, Motion

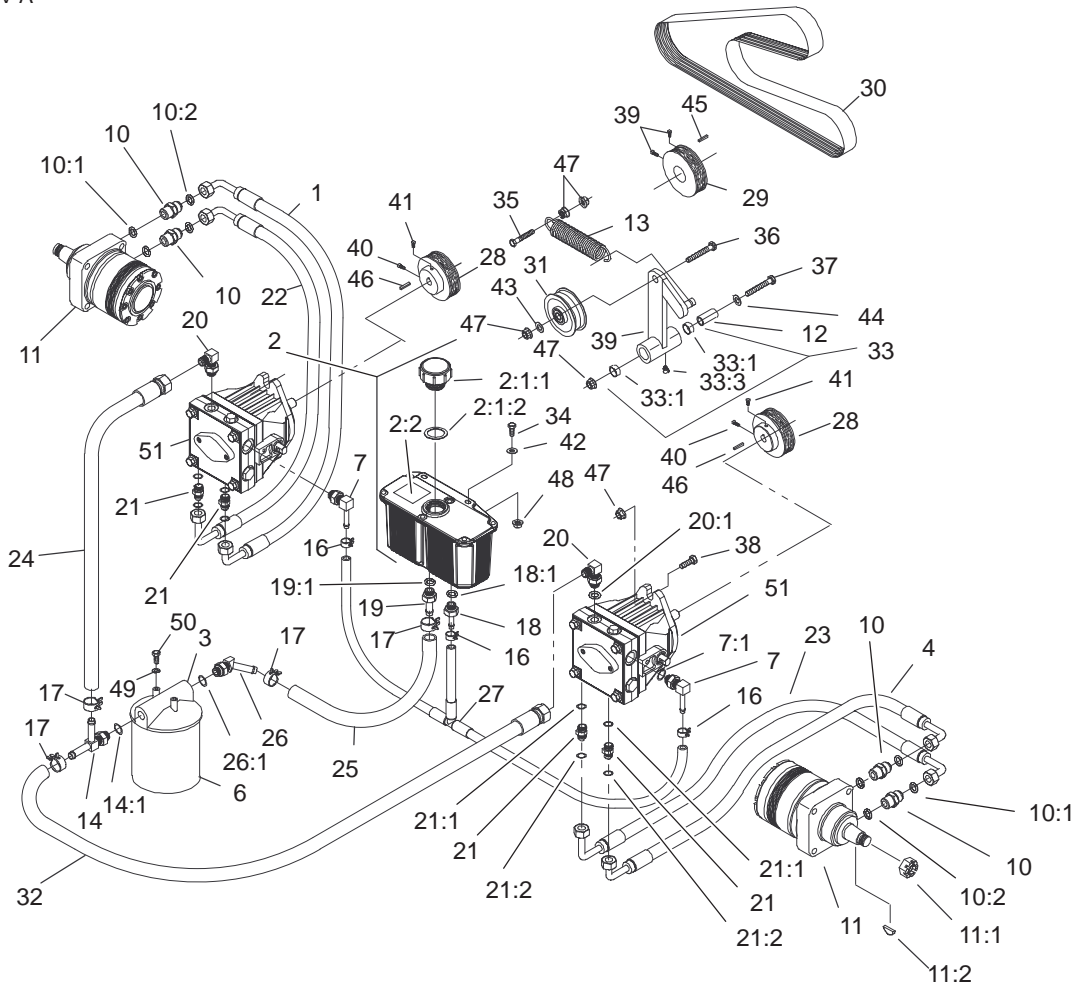

Sheet No.: 7

## Hydraulic System Assembly

Ref. No.	Part No.	Qty.	Description
1	103-1764	1	Upper RH Hose ASM
2	103-1947	1	HYD Reservoir ASM
☆2:1		1	Reservoir-HYD
2:1:1	103-1948	1	Cap-Reservoir, HYD
2:1:2	103-1949	1	Gasket-Cap
2:2	1-523552	1	Decal-Tank, HYD
3	104-7836	1	Head-Filter
4	103-1682	1	Upper LH Hose ASM
6	1-633752	1	Filter-HYD, Winter
6	1-633750	1	Filter-HYD
7	103-1799	2	Elbow-90°
7:1	237-42	1	O-Ring
10	1-603991	4	Fitting-Straight
10:1	237-80	1	O-Ring
10:2	1-603992	1	O-Ring
11	1-523328	2	Motor-Wheel
11:1	1-809036	1	Nut-HH
11:2	3257-42	1	Key-Woodruff
*11:99	1-000099	1	Seal Kit
*11:99	1-000139	1	Bearing Kit
*11:99	103-2748	1	Drive Link Kit
12	1-603384	1	Bushing-Pivot, Idler
13	1-633151	1	Spring-Extension
14	103-1828	1	Adapter-Run, Tee
14:1	237-42	1	O-Ring
16	103-1716	3	Clamp-Hose

Ref. No.	Part No.	Qty.	Description
17	103-1988	4	Clamp-Hose
18	103-1801	1	Adapter-Straight
18:1	237-42	1	O-Ring
19	103-1912	1	Adapter-Straight
19:1	237-42	1	O-Ring
20	103-1802	2	Elbow-HYD, 90°
20:1	237-42	1	O-Ring
21	1-603990	4	Fitting-Straight
21:1	237-79	1	O-Ring
21:2	1-603992	1	O-Ring
22	103-1765	1	Lower RH Hose ASM
23	103-1683	1	Lower LH Hose ASM
24	103-1826	1	HYD Hose ASM
25	103-1808	1	Hose-HYD
26	103-1807	1	Elbow-45°
26:1	237-42	1	O-Ring
27	103-1806	1	HYD Hose ASM
28	1-633568	2	Sheave
29	1-633567	1	Sheave
30	1-633749	1	Belt-Drive, Pump
31	1-633167	1	Sheave-Idler
32	103-1827	1	HYD Hose ASM
33	1-634277	1	Bearing Arm ASM
33:1	1-513034	2	Sleeve-Bearing
33:3	302-40	1	Fitting-Grease
34	321-6	2	Screw-HH

☆ Not serviced separately

\* Not illustrated



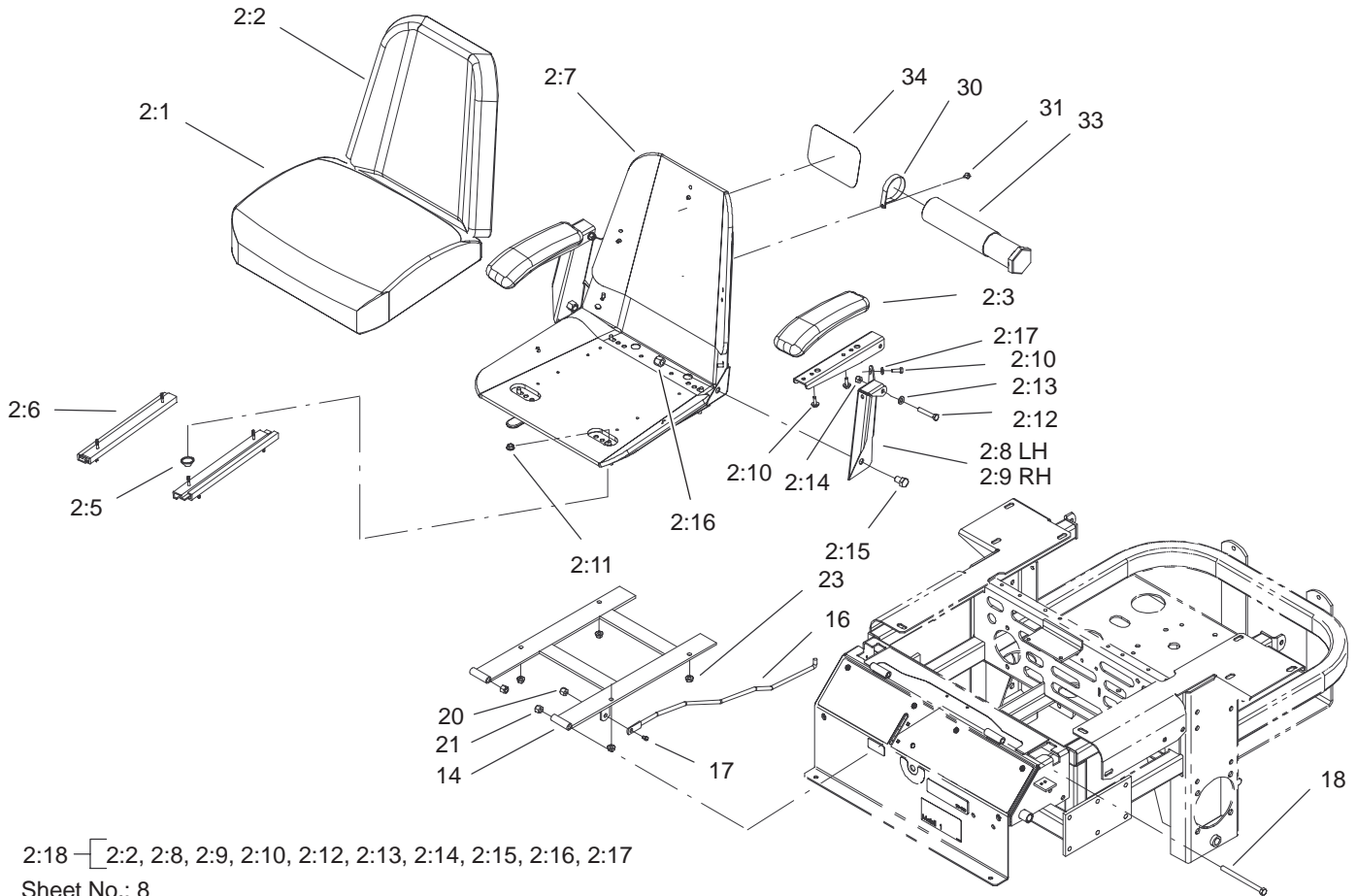

## Seat Assembly

Ref. No.	Part No.	Qty.	Description
2	1-633705	1	Seat ASM
2:1	103-0290	1	Cushion-Seat, Bottom
2:2	104-7754	1	Cushion-Seat, Back
2:3	1-633710	2	Cushion-Armrest
2:5	1-543401	4	Spacer-Track
2:6	1-643255	1	Track-Seat
2:7	1-633859	1	Frame-Seat
2:8	105-3622	1	Bracket-Armrest, LH
2:9	105-3621	1	Bracket-Armrest, RH
2:10	321-4	11	Screw-HH
2:11	32128-20	4	Nut-HF
2:12	322-10	2	Screw-HH
2:13	3256-23	4	Washer-Flat
2:14	3296-29	2	Nut-Lock, NI
2:15	325-2	2	Screw-HH
2:16	3296-23	2	Nut-Lock, NI
2:17	3256-22	11	Washer-Flat
2:18	105-3620	1	Kit-Armrest
14	1-632187-03	1	Frame-Seat
16	1-633293	1	Rod-Holdup, Seat
17	322-5	1	Screw-HH
18	323-39	2	Screw-HH
20	3296-29	1	Nut-Lock, NI
21	3296-39	2	Nut-Lock, NI
23	32128-20	4	Nut-HF
30	2412-120	2	R-Clamp

Ref. No.	Part No.	Qty.	Description
31	32104-76	2	Screw
33	74-0720	1	Tube-Manual
34	99-4693	1	Decal-Toro







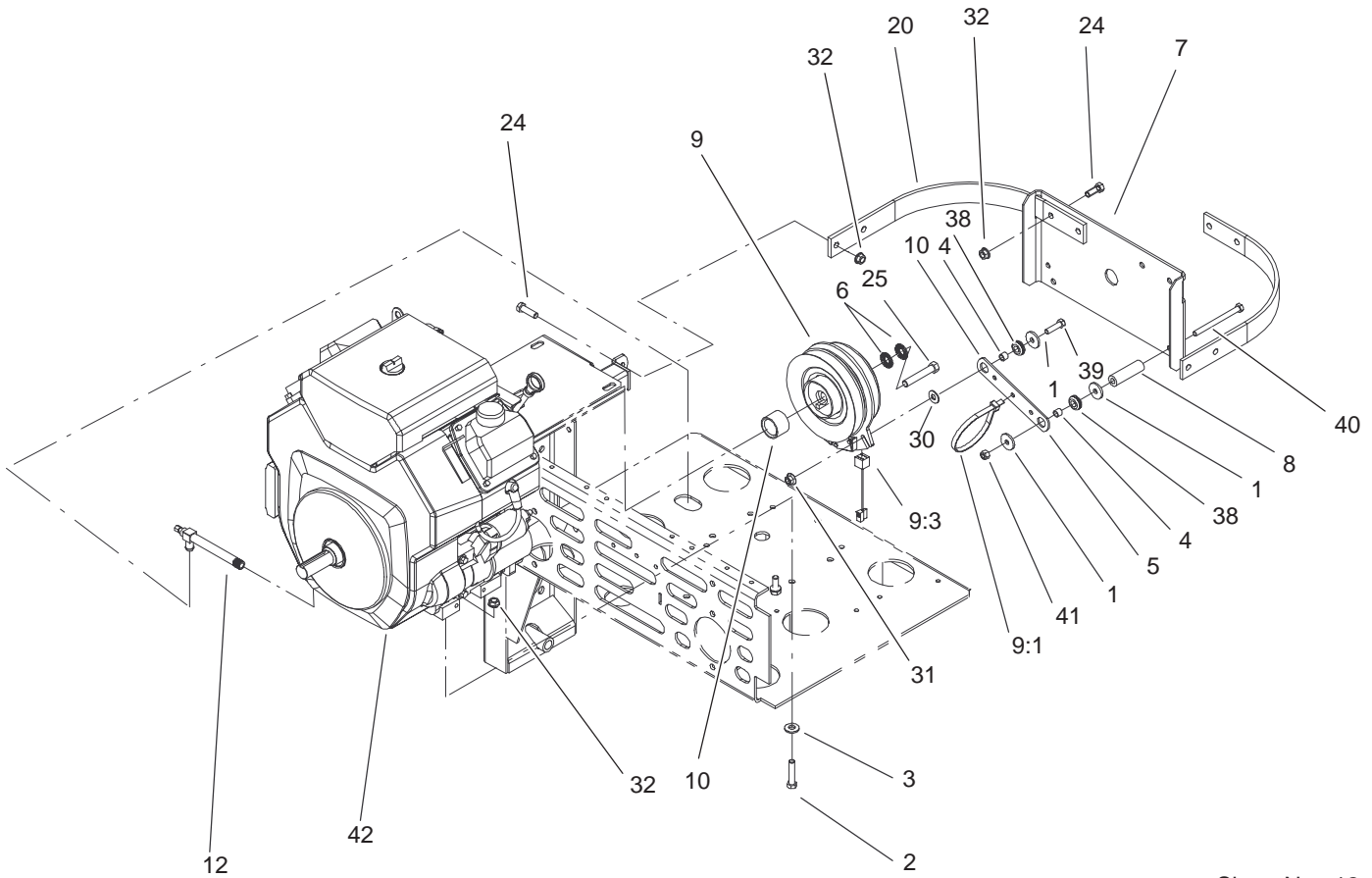

Sheet No.: 12

## Engine and Clutch Assembly

Ref. No.	Part No.	Qty.	Description
1	1-613235	4	Washer
2	323-9	4	Screw-HH
3	98-5975	4	Washer-Belleville
4	1-633545	2	Spacer-Grommet
5	1-633543-03	1	Strap-Clutch, Brake
6	1-603610	2	Washer-Spring
7	1-633615-03	1	Guard-Clutch
8	1-633988	1	Spacer-Anchor, Clutch
9	103-0665	1	Clutch ASM
9:1	1-303335	1	Tie-Plastic
9:3	105-1670	1	Harness-Jumper, Clutch
10	1-633179	1	Spacer-Clutch
12	103-1996	1	Valve-Oil Drain, Long
20	1-643264-03	2	Bracket-Guard, Top
24	323-6	6	Screw-HH
25	3212-10	1	Screw-HH
30	3256-3	1	Washer-Flat
31	32128-20	1	Nut-HF
32	3290-357	8	Nut-HHF
38	1-633630	2	Grommet-Brake
39	322-6	1	Screw-HH
40	322-19	1	Screw-HH
41	3296-29	1	Nut-Lock, NI

Ref. No.	Part No.	Qty.	Description
☆42		1	Engine-Kohler, Ch740s-0007

☆ Not serviced separately

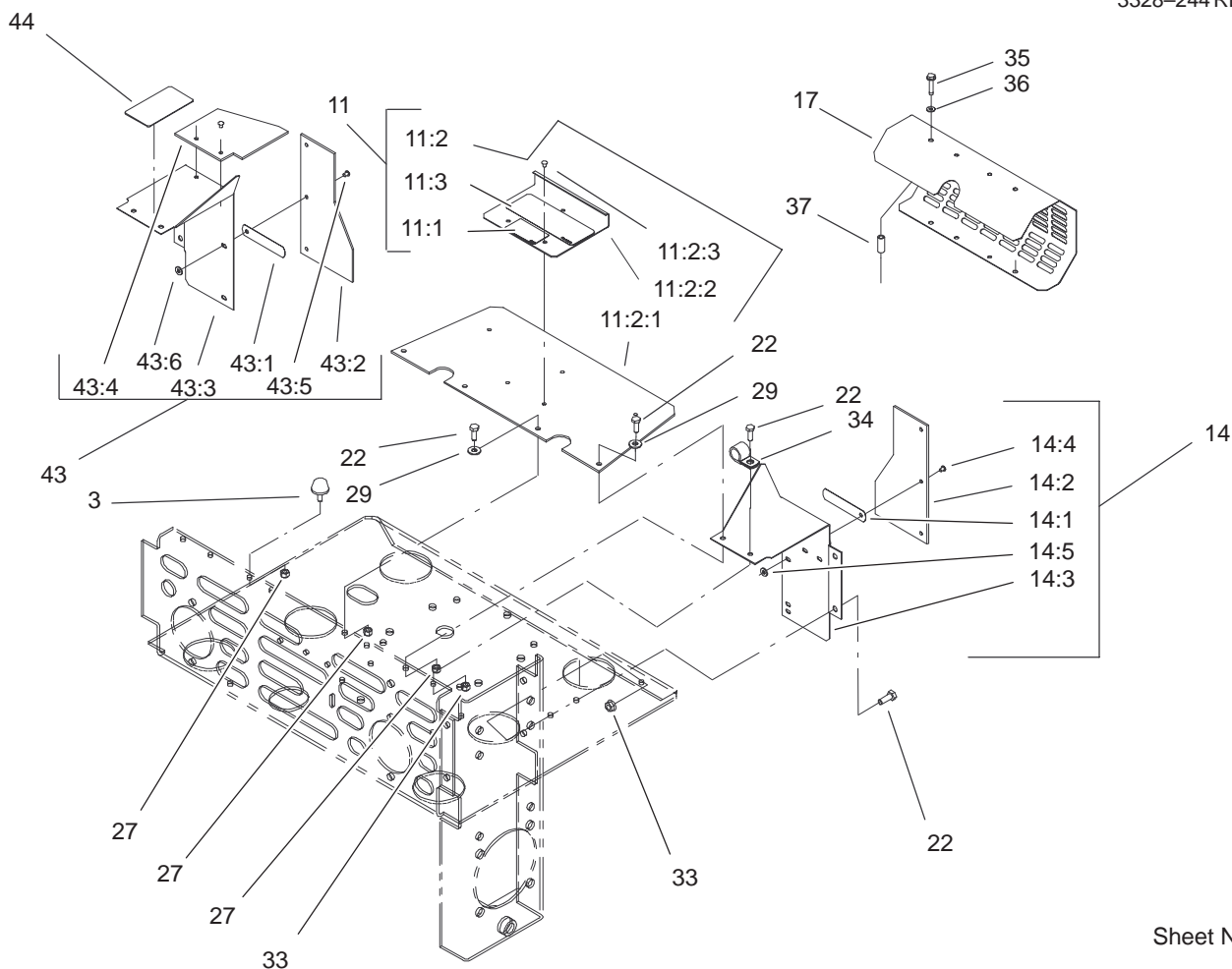

Sheet No.: 13

### Guard Assembly

Ref. No.	Part No.	Qty.	Description
3	1-523420	2	Bumper
11	1-644276	1	Shield ASM
11:1	1-633462	1	Decal-Important
11:2	1-634308	1	Shield/Lift ASM
11:2:1	103-1308	1	Shield-Engine
11:2:2	1-633300-03	1	Lift-Shield
11:2:3	1-803035	3	Rivet-Pop
11:3	103-0368	1	Decal-Devices, Rotating
14	1-634796	1	LH Shield ASM
14:1	1-523285	1	Clip-Baffle, Rear
14:2	1-633301	1	Shield-Engine
14:3	1-633795-03	1	Baffle-Engine Shield, LH
14:4	1-803035	3	Rivet-Pop
14:5	3256-63	3	Washer-Flat
17	1-643313-03	1	Guard-Muffler
22	321-4	10	Screw-HH
27	3296-42	6	Nut-Lock, NI
29	3256-2	4	Washer-Flat
33	32128-33	5	Nut-HF
34	1-633396	1	Clip-Loom
35	1-809076	2	Screw
36	1-323235	2	Washer-Spring
37	1-323236	2	Spacer
43	1-644316	1	RH Shield ASM

Ref. No.	Part No.	Qty.	Description
43:1	1-523285	1	Clip-Baffle, Rear
43:2	1-633301	1	Shield-Engine
43:3	1-633794-03	1	Baffle-Engine Shield, RH
43:4	1-643315	1	Baffle-Cooler, Engine
43:5	1-803035	5	Rivet-Pop
43:6	3256-63	5	Washer-Flat
44	1-643339	1	Decal-Routing, Belt



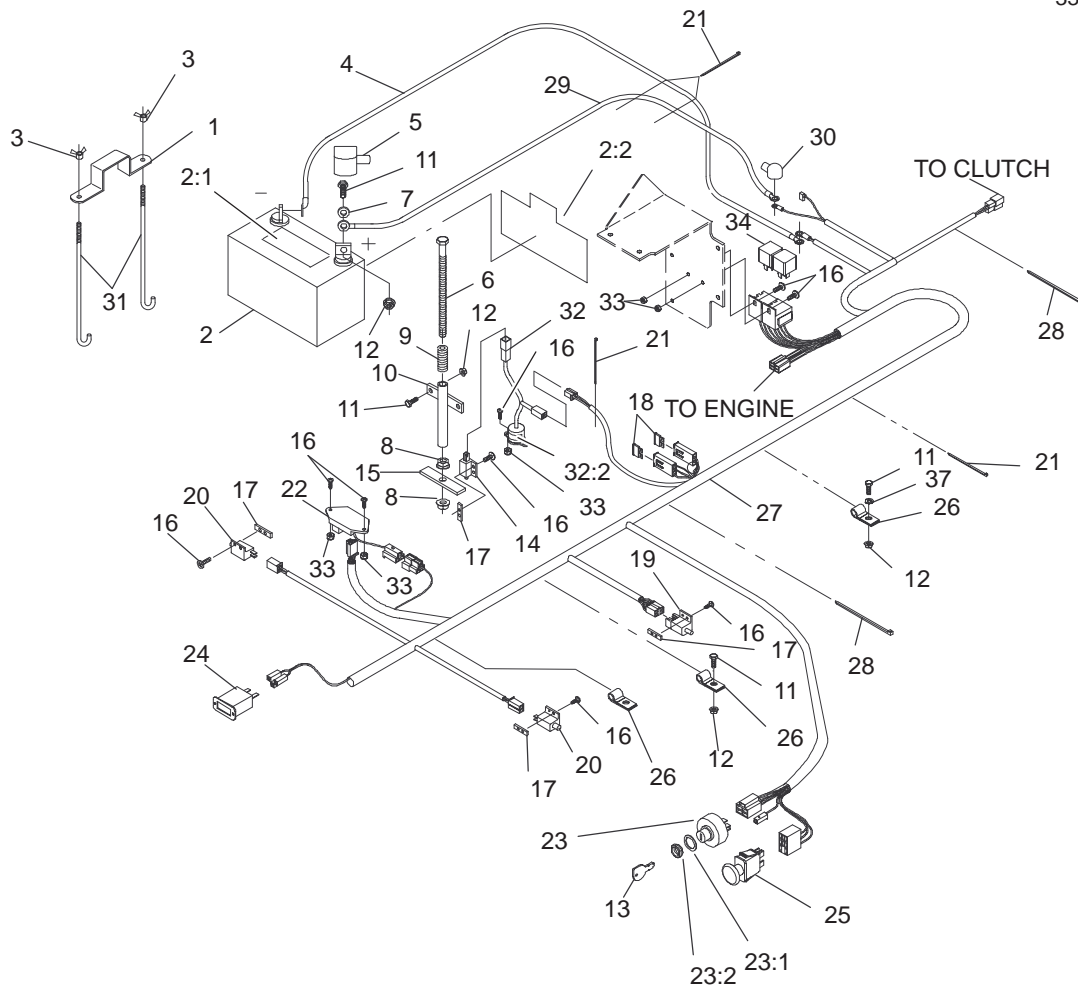

Sheet No.: 27

## Electrical System Assembly

Ref. No.	Part No.	Qty.	Description
1	1-633652-03	1	Strap-Holddown
2	105-1692	1	Battery
2:1	104-4163	1	Decal-Battery
2:2	104-4164	1	Decal-Battery
3	1-543792	2	Wingnut
4	1-633307	1	Wire-Ground
5	1-543391	1	Insulator-Battery
6	1-800282	1	Screw-HH
7	3256-2	2	Washer-Flat
8	32128-20	2	Nut-HF
9	1-523415	1	Spring-Switch, Seat
10	1-522424-03	1	Mount-Spring, Seat
11	321-4	6	Screw-HH
12	32128-33	6	Nut-HF
13	63-8360	2	Key-Ignition
14	1-513152	1	Switch-Closed, Normally
15	1-513180	1	Plate-Switch, Seat
16	3290-500	14	Screw-PPH
17	1-633181	4	Plate-Tapped
18	1-816001	2	Fuse-Type, Blade
19	1-633111	1	Switch
20	1-513051	2	Switch-Open, Normally
21	1-303287	5	Tie-Plastic
22	100-6186	1	Module-Delay, Seat

Ref. No.	Part No.	Qty.	Description
23	88-9830	1	Key Switch ASM
23:1	3254-5	1	Washer-Lock, Internal
23:2	218-461	1	Nut-HH
24	1-513374	1	Meter-Hour
25	1-633673	1	Switch-Delta
26	1-633396	3	Clip-Loom
27	100-4340	1	Harness-Wire
28	1-303335	2	Tie-Plastic
29	1-523281	1	Wire-Starter
30	1-543393	1	Insulator-Solenoid
31	1-633651	2	Bolt-Holddown
32	1-644427	1	Tilt Switch ASM
32:2	1-643401	1	Decal-Switch, Mercury
33	3296-2	6	Nut-Lock
34	1-643275	2	Relay
37	3256-22	1	Washer-Flat



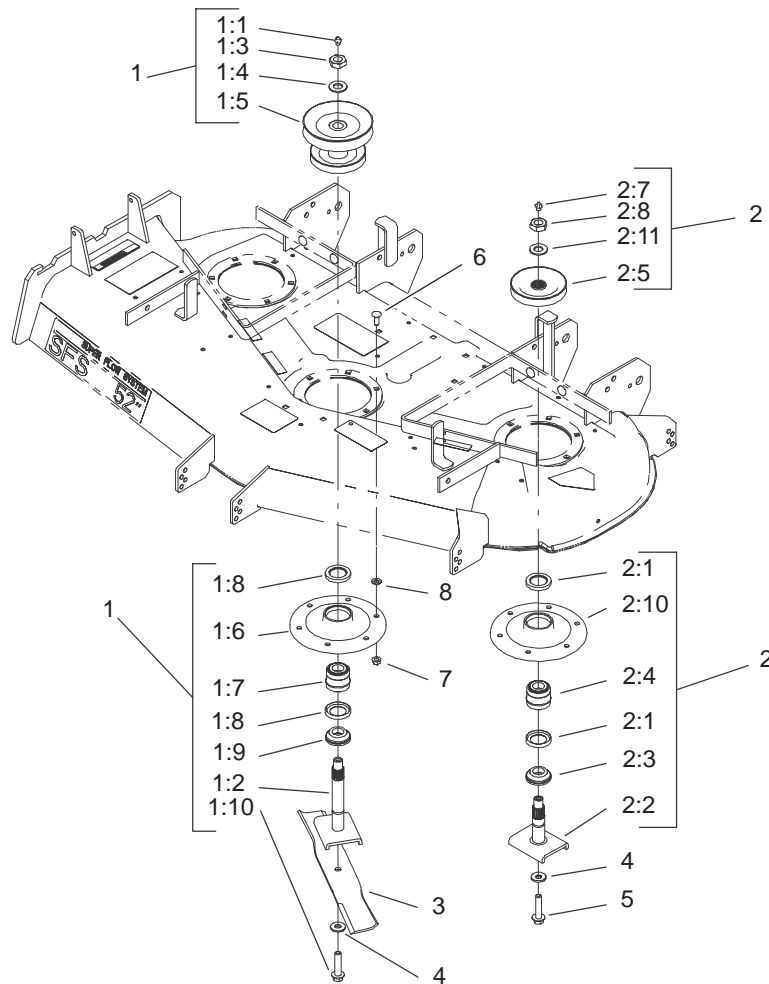

Sheet No.: 52

## Spindle and Pulley Assembly

Ref. No.	Part No.	Qty.	Description
1	105-1687	1	Spindle Housing ASM
1:1	302-2	1	Fitting-Grease
1:2	105-1686	1	Spindle Shaft ASM
1:3	32146-20	1	Nut-Jam
1:4	92-5836	1	Washer
1:5	100-2312	1	Pulley/Hub ASM
1:6	61-4160	1	Housing
1:7	46-8530	1	Bearing ASM
1:8	253-139	2	Seal-Oil
1:9	27-0950	1	Spacer
1:10	92-5816	1	Bolt-Blade
2	99-4639	2	Outer Spindle ASM
2:1	253-139	2	Seal-Oil
2:2	27-0920	1	Shaft
2:3	27-0950	1	Spacer
2:4	46-8530	1	Bearing ASM
2:5	99-4613	1	Pulley ASM
2:7	302-2	1	Fitting-Grease
2:8	32146-20	1	Nut-Jam
2:10	61-4160	1	Housing
2:11	7-4150	1	Washer
3	27-0990	3	Blade
4	1-513435	3	Washer-Spring
5	92-5816	2	Bolt-Blade
6	3231-22	16	Screw-CARR

Ref. No.	Part No.	Qty.	Description
7	32128-21	16	Nut-HF
8	3256-24	1	Washer-Flat









