



Grooming Reel Kit
Greensmaster® 3000 Cutting Unit
Model No. 04455

Form No. 3314-585 Rev A

Operator's Manual

Setup

Loose Parts

Note: Use this chart as a checklist to ensure that all parts necessary for assembly have been received. Without these parts, total setup cannot be completed. Some parts may have already been assembled at the factory.

Description	Qty.	Use
Frame Assembly, R.H.	3	Attaches to right frame
Frame Assembly, L.H.	3	Attaches to left frame
Bearing Adapter	6	Connects groomer to reel frame
Spacers	12	Connects groomer to reel frame
Bearing Adapter Studs	6	Fastens bearing adapters
Flat Head Screws	6	Fastens bearing adapters
Lock Nut	12	Fastens bearing adapters
Lock Nut	6	Secures hydraulic motor
Grooming Reel Assembly	3	41 blades, 1/2" spacing
Driven Pulley	3	Attaches to grooming reel
Lock Nut	3	Attaches to grooming reel
Roller Extension Assembly, R.H.	3	Holds roller
Roller Extension Assembly, L.H.	3	Holds roller
Clutch Assembly	3	Drives belt
Driven Belt	3	Drives grooming reel
Splined Nut	3	Replaces right side reel nut
Pivot Screw and Washer	6	Replaces SPA shield pivots
Loctite RC 680	.5 ml.	Apply to reel extension shaft
Parts manual	1	
Operator's manual	1	

Important Read this Operator's Manual thoroughly before setting up or operating the groomer. Failure to follow set up or operating instructions in this manual may result in damage to the cutting unit and/or the groomer or the turf.

Important The additional weight of the grooming reel requires that the Greensmaster 3000 Frame Brace Kit, Part No. 63-9990, be added to all traction units prior to Model No. 04350, Serial No. 80437. Some older model traction unit lift arms have sharp top edges that could cause excessive cutting unit lift bail wear. This can be prevented by rounding off the edges with a file.

Note: The Greensmaster 3000 Grooming Reel Kit fits the following Toro riding greens mower cutting units: 04405, 04406, 04407, 04408, 04440, 04450, 04458 and 04468.

Note: Terms *left* and *right* used in the text refer to left and right sides of the unit as viewed from operator's seated position.

The following installation procedures apply to both Single Point Adjustment (SPA) cutting units (Models 04440, 04448, 04450, 04458 & 04468) and 4 Bolt Adjustment (4 Bolt) cutting units (Models 04405, 04406, 04407 & 04408).

1. Remove grass shield assembly. On all units, save the (2) hex head capscrews, (4) flatwashers and (2) locknuts for reuse (Fig. 1 & 2). Discard the two pivot screws and lockwashers on SPA units (Fig. 1).

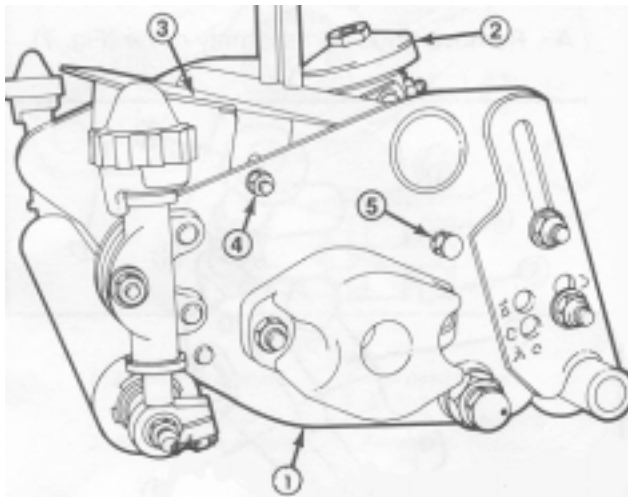

Figure 1

- | | |
|--|--|
| 1. Single point adjustment cutting unit (SPA) | 4. Shield fastening capscrew and locknut (2) |
| 2. Bedknife adjusting knob (i.e. single point) | 5. Pivot screws and lockwashers (2) |
| 3. Shield | |

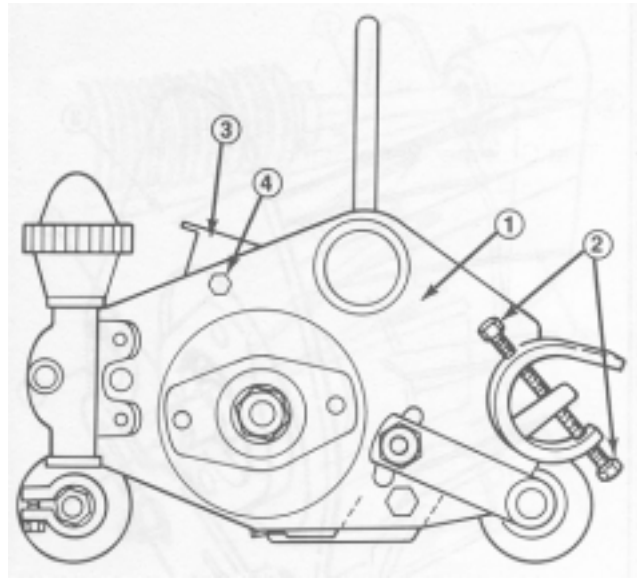

Figure 2

- | | |
|---|--|
| 1. Four bolt cutting unit (i.e. 4 Bolt) | 3. Shield |
| 2. Bedknife adjusting screws (4) | 4. Shield fastening capscrew, washer, lockwasher & hex nut (2) |

2. Remove the carriage bolts, flat head machine screws and capscrews securing the two front height of cut brackets and remove brackets and front roller (Fig. 3). Discard all parts except the roller.

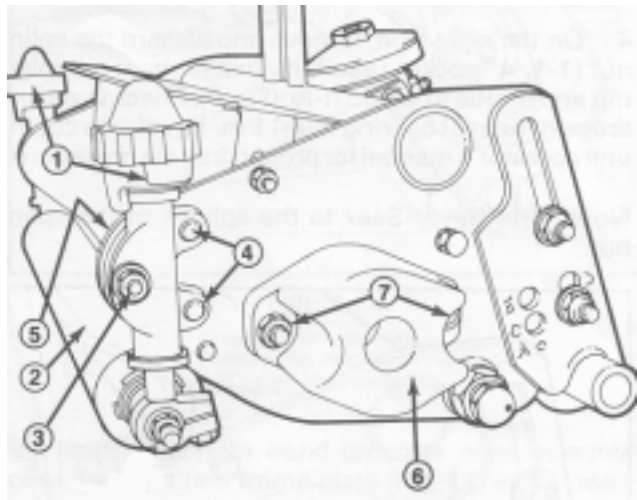

Figure 3

- | | |
|--------------------------------------|--|
| 1. Front height of cut brackets (2) | 5. Capscrew and lockwasher (2) (hidden behind plate) |
| 2. Front roller | 6. Left side counter balance end cap |
| 3. Carriage bolt, washer and nut (2) | 7. Locknut (4) |
| 4. Flat head machine screw (4) | |

3. Disassemble two locknuts and remove the left side counterbalance (Fig. 3) and remove the backlap screw (Fig. 4). Discard all parts.

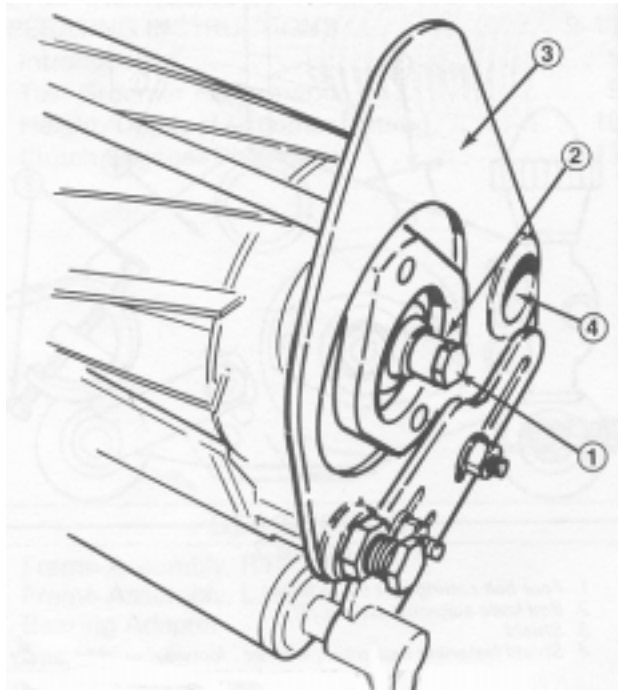

Figure 4

- | | |
|-------------------------|--------------------|
| 1. Backlap screw | 3. Left reel frame |
| 2. Reel shaft extension | 4. Reel frame tube |

4. On the right side, remove and discard the splined nut (1-1/4" socket required).
5. Apply Loc Tite 242 (not supplied with kit) to threads of new splined nut.
6. Install the new splined nut and torque to 45-55 ft-lb. (Fig. 5). Check to ensure drag on reel bearing is 7-11 in-lb; refer to cutting unit Operator's Manual for proper drag set procedures.

Note: Add Never-Seez to the splines of the splined nut.

7. On the left side, measure the reel shaft extension diameter (Fig. 4). The diameter, over the length of the shaft, must be between .621" to .626" to allow the clutch adapter to fit over the extension. If the shaft diameter exceeds .626" reduce it by hand rotating the shaft and applying a file or emery cloth. Ensure the internal shaft threads are free of rust and debris.

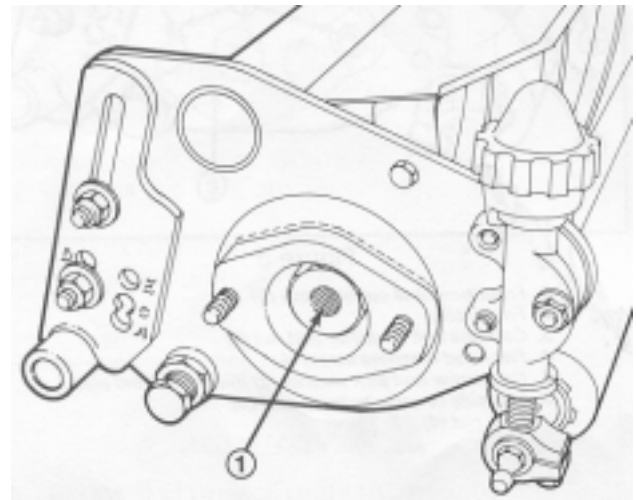

Figure 5

1. Right side splined nut

8. On each end, unscrew the machine screws securing the reel bearing housings to allow the screw heads to be cut off. Cut off the screw heads (Fig. 6). From the outside of the unit, back the remainder of the screws out away from the reel with a screwdriver or pliers.

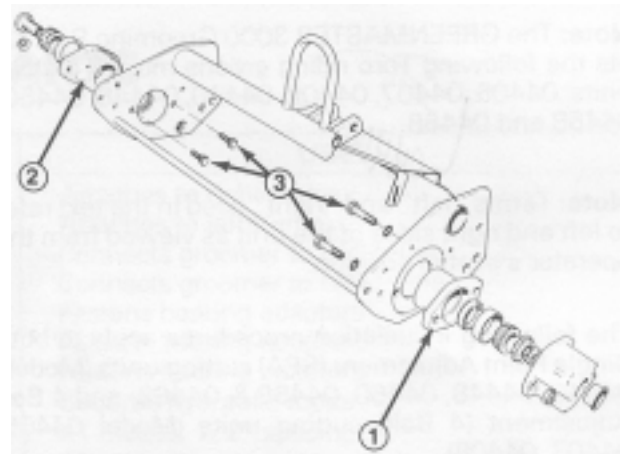

Figure 6

- | | |
|-------------------------------|-----------------------|
| 1. Left reel bearing housing | 3. Machine screws (4) |
| 2. Right reel bearing housing | |

9. Install the left grooming reel housing onto the left reel frame as follows:

- A. Remove the housing assembly cover (Fig. 7).

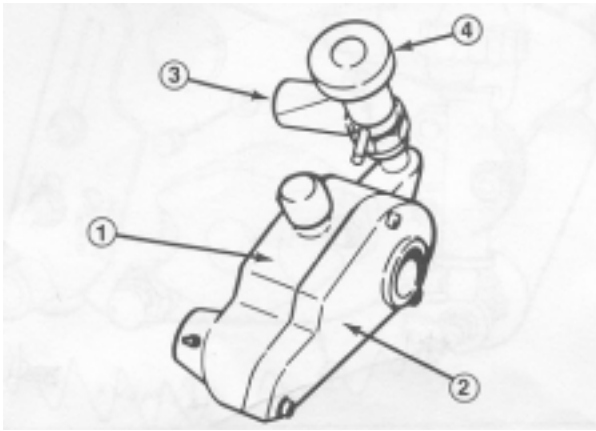

Figure 7

- | | |
|---------------------------------------|-----------------------------|
| 1. Left groomer reel housing assembly | 3. Mounting block |
| 2. Housing cover | 4. Adjustment knob assembly |

B. Disassemble the adjustment knob assembly and separate the mounting block from the assembly (Fig. 7). Discard cotter pin (pin for shipping purpose only).

	Caution	
The adjustment knob assembly is spring loaded.		

C. Remove paint and flash from inside the reel frame tube (Fig. 4). Insert the mounting block into the reel frame tube and tighten socket head capscrew enough to hold the assembly in the tube.

D. Install flathead screws (3/8–16 x 1–3/4”) through bearing adapter and position spacers on the ends of the screws. Align bearing adapter and spacers with bronze bearing and slots in groomer belt housing. Mount belt housing assembly to cutting unit bearing housing and torque flathead screws to 17–21 ft–lb. Assemble locknuts to the flathead screws and torque to 23–27 ft–lb (Fig. 8)

10. Slide the grooming shaft assembly into the bearing support in the left belt housing (Fig. 9). Using a 3/8” allen socket and torque wrench, install the driven pulley (left–hand thread) and torque to 29–32 ft–lb (Fig. 10).

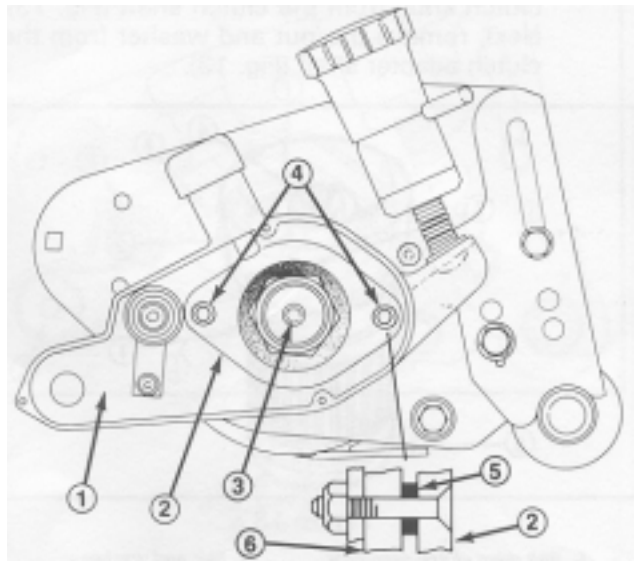

Figure 8

- | | |
|------------------------------|---------------------------------|
| 1. Left side groomer housing | 5. Spacer |
| 2. Bearing adapter | 6. Cutting unit bearing housing |
| 3. Reel bearing housing | |
| 4. Flat head screw | |

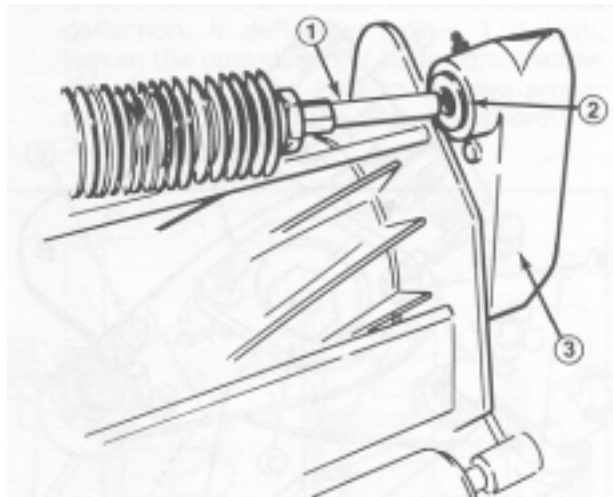

Figure 9

- | | |
|---------------------------|---------------------------|
| 1. Groomer shaft assembly | 3. Left side cast housing |
| 2. Bearing support | |

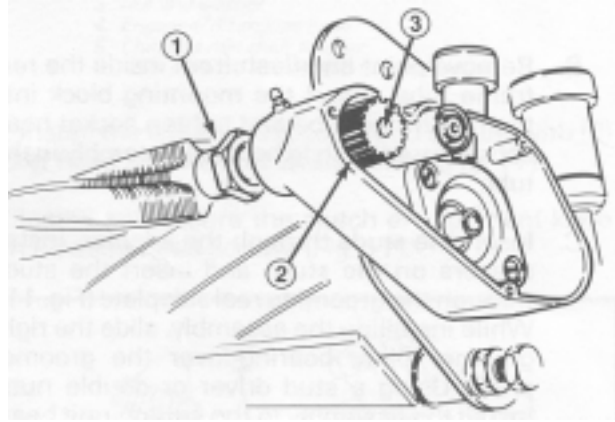

Figure 10

- | | |
|-------------------------------------|---------------------------|
| 1. Groomer shaft assembly | 3. 3/8" allen head socket |
| 2. Driven pulley (left hand thread) | |

11. Install the right hand groomer plate assembly onto the right reel frame plate (Fig. 11) as follows:

A. Disassemble the adjustment knob assembly and separate the mounting block from the assembly (Fig. 11).

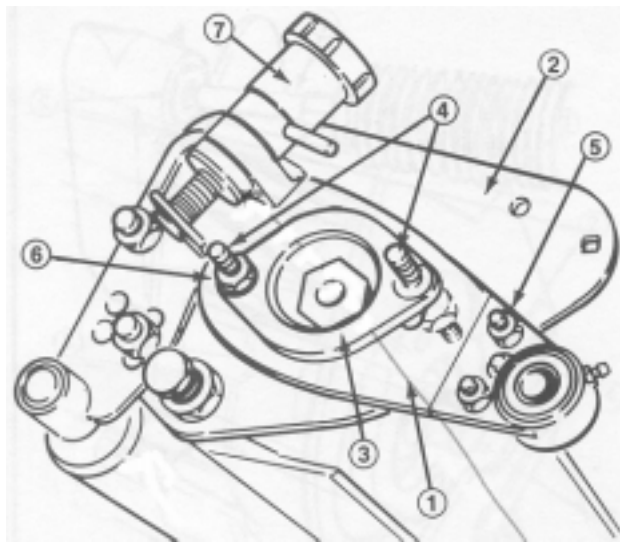

Figure 11

- | | |
|---------------------------------------|-----------------------------|
| 1. Right side, groomer plate assembly | 5. Inside locknuts (2) |
| 2. Right reel frame plate | 6. Outside locknuts (2) |
| 3. Groomer bearing adapter | 7. Adjustment knob assembly |
| 4. Special studs (2) | |

Caution

The adjustment knob assembly is spring loaded.

B. Remove paint and flash from inside the reel frame tube. Insert the mounting block into the reel frame tube and tighten socket head capscrew enough to hold the assembly in the tube.

C. Insert the studs through the adapter, install spacers on the studs and insert the studs through the grooming reel sideplate (Fig. 11). While installing the assembly, slide the right groomer plate bearing over the groomer shaft. Using a stud driver or double nuts, install the assembly to the cutting unit bearing housing. Torque the studs to 17–21 ft-lb.

D. Assemble locknuts to the studs and torque to 23–27 ft-lb.

E. Thread flange locknuts onto each stud. These eventually will be use to mount the reel drive motor (Fig. 11).

F. Install locknut on right side of groomer shaft (left hand thread) and torque to 29–35 ft-lb.

12. Align mounting block from adjustment knob assembly with the belt drive housing. Insert the quick up ramp into the mounting block. From the underside, insert the carriage bolt through the hole in the belt drive housing, up through the quick up ramp and mounting block. Rotate the mounting block, if necessary, to allow the carriage bolt to pass through and center it in the mounting block, quick up ramp assembly.

13. Remove the carriage bolt and quick up ramp. Hold the mounting block in position and tighten the allen head set screw to secure the mounting block assembly into the cutting unit cross tube (Fig. 12).

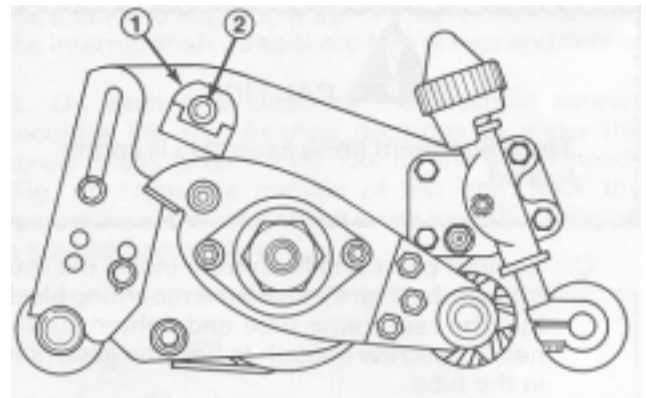

Figure 12

- | | |
|-------------------|----------------|
| 1. Mounting block | 2. Allen screw |
|-------------------|----------------|

14. Repeat steps 10 and 11 on the opposite side. Assemble both adjustment knobs assemblies. Apply grease to threads on locking knob assemblies and tighten large nuts (Fig. 11).

15. Install the belt drive clutch as follows:

- A. Loosen two allen set screws and remove the clutch knob from the clutch shaft (Fig. 13). Next, remove the nut and washer from the clutch adapter shaft (Fig. 13).

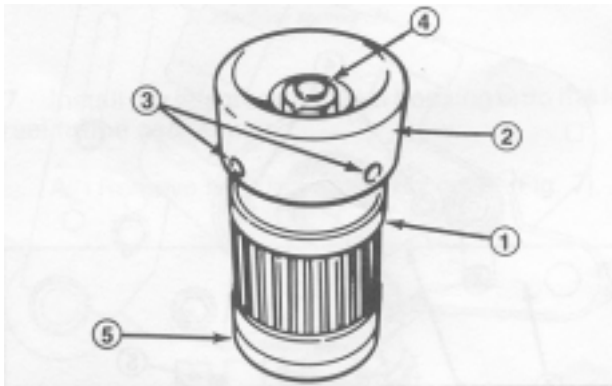

Figure 13

- | | |
|-------------------------------|------------------------------|
| 1. Belt drive clutch assembly | 3. Allen head set screws (2) |
| 2. Engaged/disengaged knob | 4. Nut and washer |
| | 5. Clutch adapter shaft |

- B. Remove the clutch adapter shaft from the clutch assembly.
- C. Apply Loctite RC 680 (supplied with kit) to outside of left reel shaft extension. **DO NOT APPLY LOCTITE TO THREADED AREAS.** Thread clutch assembly onto left reel shaft extension (Fig. 14). Secure the reel from turning with a block of wood and torque the clutch adapter to 17 ft-lb.

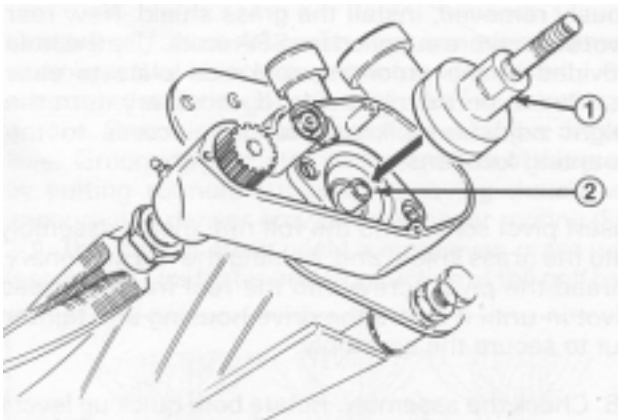

Figure 14

- | | |
|-------------------------|-------------------------|
| 1. Clutch adapter shaft | 2. Reel shaft extension |
|-------------------------|-------------------------|

- D. Fit the toothed belt over the drive pulley (removed in step 13B). Hold the belt in position and slide the drive pulley in place on the clutch adapter while positioning the belt around the driven pulley and under the backside idler (Fig. 15).

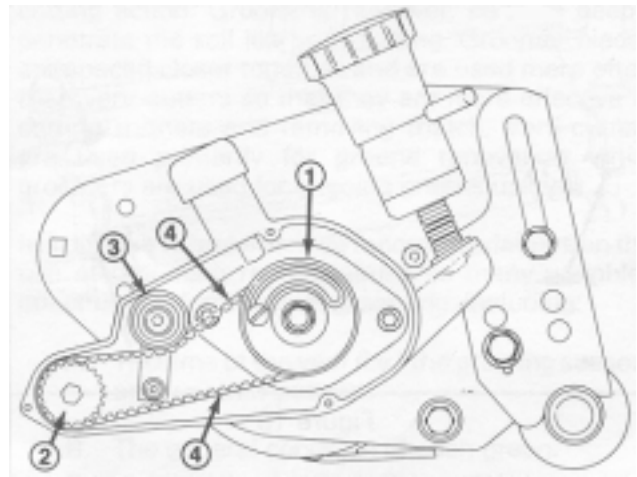

Figure 15

- | | |
|------------------|-------------------|
| 1. Drive pulley | 3. Backside idler |
| 2. Driven pulley | 4. Drive belt |

Important If the clutch mechanism has separated due to removal of the nut and washer (step 13A), ensure the belleville washers are properly installed; refer to figure 16.

- E. Install the washer and nut (removed in 13A) onto clutch adapter shaft. Secure the reel from turning with a block of wood and torque to 10–14 ft-lb.
- F. Apply 5–10 lbs. of force on the belt midway between the pulleys to check tension on the drive belt. There should be 1/4 inch belt deflection. If deflection is not 1/4 inch, loosen the backside idler pulley pivot screw (Fig. 15). Pivot the idler to achieve proper tension and torque the allen head screw to 7–10 ft-lb.

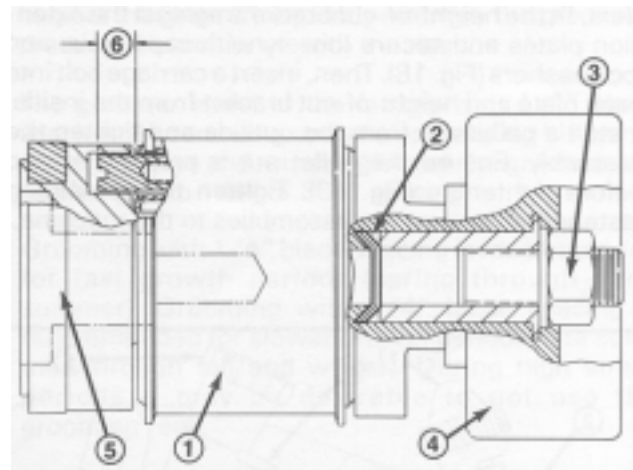

Figure 16

- | | |
|---------------------------|---|
| 1. Clutch body | 5. Clutch to reel shaft adapter |
| 2. Belleville washers (2) | 6. .250 inch \pm .010 (with pin fully extended) |
| 3. Nut and washer | |
| 4. Engaged/disengage knob | |

16. Install the left housing cover and secure with (3) socket head screws and lockwashers (Fig. 17).
17. Install and secure the clutch engagement knob with (2) allen head screws (Fig. 17).

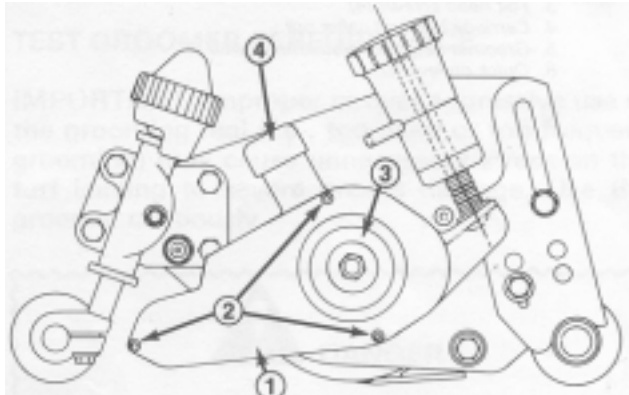

Figure 17

- | | |
|---------------------------------------|---------------------------------|
| 1. Left assembly housing cover | 3. Clutch engagement knob cover |
| 2. Socket head screws and washers (3) | 4. Clutch snubber |

18. Mount the right and left roller extension assemblies over the roller shaft. Use flat head screws and locknuts in the top holes and hex head capscrews and locknuts in the lower holes to secure the roller extension plates to the side plates (Fig. 18).

Note: When installing a grooming reel kit on a 4-bolt adjustment cutting unit, two different roller extension plates must be used, Part No. 70-2320 and Part No. 70-2330. These parts are included in the kit, and are marked with 4-bolt on the plate.

Next, fit the height of cut brackets against the extension plates and secure loosely with capscrews and lockwashers (Fig. 18). Then, insert a carriage bolt into each plate and height of cut bracket from the inside, install a pallet nut from the outside and tighten the assembly. Ensure the pallet nut is properly seated before tightening (Fig. 18). Tighten the remaining fasteners to secure the assemblies to the machine.

19. Using capscrews, flatwashers and locknuts previously removed, install the grass shield. New rear pivot screws are supplied for SPA units. Use the hole provided in the grooming reel side plate to ease installation on the right side. If necessary, turn the height adjustment knob to gain access to the mounting locations.

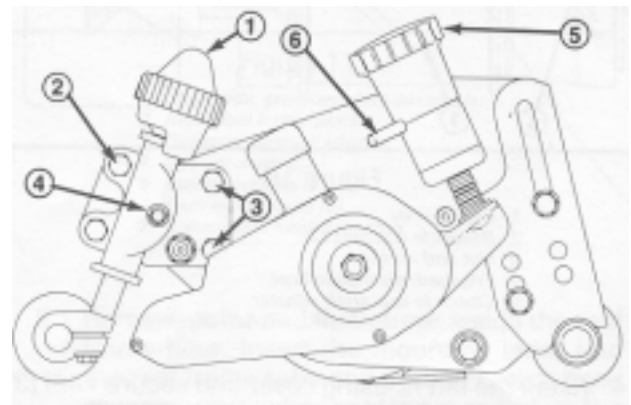

Figure 18

- | | |
|---|--------------------------------------|
| 1. Left roller extension assembly (i.e. front height of cut adjustment bracket) | 3. Flat head screws (4) |
| 2. Cap screw and locknut hidden behind assembly (2) | 4. Carriage bolt and pallet nut |
| | 5. Groomer height of adjustment knob |
| | 6. Quick up lever (2) |

Insert pivot screw into the full nut, install assembly into the grass shield and, holding the nut stationary, thread the pivot screw into the reel frame. Thread pivot in until it clears the drive housing and tighten nut to secure the assembly

20. Check the assembly. Rotate both quick up levers to raise the grooming reel into transport position (Fig. 18). Hold the clutch snubber down and rotate the clutch knob clockwise to disengage the clutch (Fig. 17). Correct any problems and recheck assembly.

21. Using a hand grease gun, lubricate the grooming reel shaft bearings (Fig. 19). Pump only 2-3 pumps maximum to avoid prematurely damaging the grease seals.

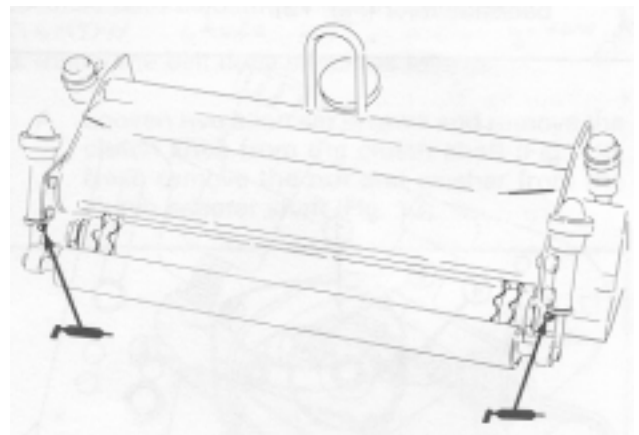

Figure 19

Operation

Introduction

Grooming golf course greens is a variation of an old technique that is receiving new found popularity. It is associated with the golfers desire for faster and truer greens. Grooming is usually performed above the soil level. Grooming promotes vertical growth of the grass by cutting runners (stolons), removing thatch and encouraging denser growth and deeper rooting (Fig. 20). This can, in effect, yield a more even grass with less "grain" for faster and truer action of the golf ball.

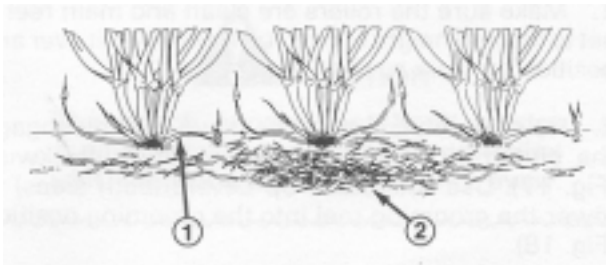

Figure 20

1. Grass runners (Stolons) 2. Thatch

Grooming is similar to verti-cutting in its runner cutting action. Grooming however, can not deeply penetrate the soil like verti-cutting. Groomer blades are spaced closer together and are used more often than verti-cutters so that they are more effective in cutting runners and removing thatch. Verti-cutters are used primarily for greens renovation while groomers are used for ongoing greens upkeep.

It is difficult to make precise recommendations on the use of grooming reels because so many variables affect the performance of grooming, including:

- A. The time of the year (i.e., the growing season) and weather pattern.
- B. The general condition of each green.
- C. The frequency of grooming/cutting—both how many cuttings per week and how many passes per cutting.
- D. The height of cut setting on the main cutting reel.
- E. The height/depth setting on the grooming reel.
- F. How long the grooming reel has been in use on this green.
- G. Type of grass on the green.
- H. The overall greens management program (i.e. irrigation, fertilizing, spraying, coring, over seeding, etc.).
- I. Traffic

- J. Stress periods (i.e., high temperatures, high humidity, unusually high traffic.)

These factors can vary from golf course to golf course and from green to green. It is important, therefore, to inspect the greens frequently and vary the grooming practice in accordance with the need.

The groomer is set at the factory with 1/2" blade spacing. By removing spacers and adding blades or by adding spacers and removing blades the groomer can be changed to 1/4" or 3/4" spacing.



Grooming with 1/4" blade spacing is recommended for fast growth periods (spring through early summer). Grooming with 3/4" spacing is recommended for slower growth periods (late summer through fall and winter). During high stress periods it may be desirable to use the grooming reel.

Note: Grooming with 1/4" blade spacing will tend to remove grass blades and thatch and cut runners. Grooming with 3/4" blade spacing primarily removes thatch and cuts runners. If grooming with 1/4" blade spacing, up to two groomings per week will probably be sufficient except during maximum growth periods.

Note: The practice of changing the direction of cut each time the green is cut should be continued when a groomer is used. This rotation will enhance the effects of the grooming

Test Groomer Performance

Important Improper or over aggressive use of the grooming reel (i.e., too deep or too frequent grooming) may cause unnecessary stress on the turf leading to severe greens damage. Use the groomer cautiously.

 **Danger** 

Before making any adjustments to cutting units, disengage the reels, set the parking brake, turn the engine off and remove the key.

It is important to determine the performance of the groomer before putting it into regular use on greens. Toro strongly suggests that a formal test procedure to be used. The following is a practical way of determining the proper height/depth setting:

1. Set the main cutting reels to the height of cut that would normally be used without the grooming reel. Use a Wiehle roller on the front and a full roller with scrapers on the rear (a Wiehle roller can be used on the rear at height of cut settings 3/16" or below but this may result in a slightly deeper cut).
2. Set each of the grooming reels at a different setting as follows:
 - A. One groomer 1/32" above the roller level.

- B. One groomer flush with the roller level.
 - C. One groomer disengaged and raised into the transport position.
3. Make a pass over the test green and look at the results. The reel with the groomer set at 1/32" above the roller will have removed more grass and thatch than the reel with the groomer disengaged. The reel with the groomer set flush with the roller level will have removed significantly more grass and thatch than the other two reels.
 4. Examine the test green and determine if one of the two areas gives the desired results. If not, lower and engage the third groomer, increase or decrease the height/depth of the groomers, and make another test pass. The amount of grass removed is a key indicator in determining the height/depth setting of the grooming reel.

Check the test green 2 or 3 days after the first grooming for general condition/damage. If the groomed areas are turning yellow/brown, and the non groomed areas are green, then the grooming was too aggressive.

Note: The color of the grass will change when the grooming reel is used. This can be observed with the first grooming and will continue over time. Experience will allow the greens superintendent to judge by color of the turf (along with close examination) if the current grooming practice is appropriate for the particular green. Because the grooming reel stands up more grass and removes thatch, the quality of the cut will not be the same as without

Note: On multiple passes (i.e., double and triple cutting), the groomer will continue to penetrate deeper on each successive pass. Multiple passes are not recommended.

5. After testing the performance of the groomer on a test green and satisfactory results are obtained, grooming on the playing greens can begin. It is important to realize, however, that each green may respond differently to grooming. In addition, grooming conditions are constantly changing. Inspect the groomed greens frequently and make adjustments to the grooming procedure as often as necessary.

Height/Depth of Groomer Setting

The groomer blade height/depth of grooming can be set using the following procedure:

1. Make sure the rollers are clean and main reel is set to desired height of cut. Turn cutting unit over and position on work surface (Fig. 21).

2. Hold the clutch snubber down and disengage the clutch by turning the clutch knob clockwise (Fig. 17). Use the Quick Up Levers (both sides) to lower the grooming reel into the grooming position (Fig. 18).
3. On one end of the cutting unit, place a gauge bar across the front and rear rollers. Measure the distance from the lowest tip of a groomer blade to the gauge bar (Fig. 21). Lift and turn the micro adjustment (Fig. 21) to raise or lower blade tip. Each notch of the micro adjustment knob is equal to approximately .007 inch of groomer depth.

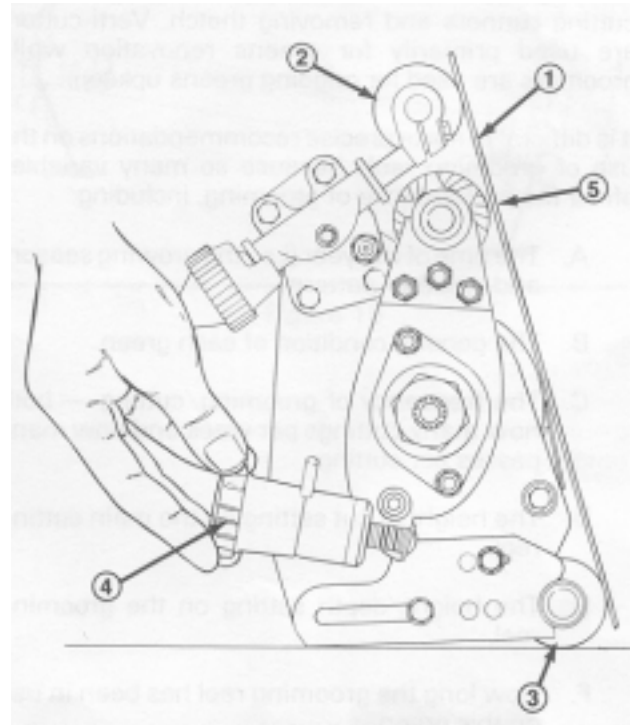

Figure 21

- | | |
|-----------------|------------------------------|
| 1. Gauge bar | 4. Micro adjustment knob (2) |
| 2. Front roller | 5. Measure distance here |
| 3. Rear roller | |
-
4. Repeat step 4 on the other side of the groomer blade. Go back to the first side and check height/ depth setting.
 5. Reinstall the cutting unit on the traction unit. Put the grooming reel into the transport position and disengage the clutch.

Clutch Engage/Disengage



Caution



The clutch engagement knob rotates during normal operation of the grooming unit. Keep loose clothing, hair, etc., away.

The grooming reel should be disengaged at all times except during grooming. To operate the clutch, depress the clutch snubber and engage the clutch by turning the clutch knob counter-clockwise, turn the clutch knob clockwise to disengage the clutch (Fig. 17).

Important When engaging or disengaging the clutch, be sure to turn the knob all the way (it will come to a firm stop). Failure to do so could cause damage to the clutch.

Transport Mode

Important When transporting the traction unit be sure to disengage the groomer clutch and raise the grooming reel into its transport (raised) position. To raise the grooming reel, rotate the right and left quick up levers so they face to the rear (Fig. 18). To lower the grooming reel, turn the quick up levers forward and engage the clutch.

Grass Basket and Rollers

When using the grooming reel with grass baskets, check the gap between the basket and the grooming reel. The reel to basket gap should be 1/4 inch. When the reel is in the fully raised (transport) position it may contact the basket and damage it if the clutch is engaged. To change the basket gap, adjust the pull arms (see procedure in the GREENSMaster Traction Unit Operator's Manual).

The grooming reel will increase the amount of grass and thatch picked up. This means the grass baskets will have to be emptied more often.

If the grooming reels are set to a negative depth relative to the rollers, the groomer will penetrate deeper than the cutting unit. Because of this, the groomer will cut into the base of the grass blade which is stickier. Grass will tend to build up on the rear roller faster than without the groomer. A rear roller scraper is strongly advised when grooming reels are used.

A Wiehle roller is recommended on the front when using a grooming reel. A Wiehle roller can also be used on the rear to avoid grass build up if the height of cut is at or below 3/16". If the height of cut is set over 3/16", then a full roller with scrapers is advised.

Maintenance

Important The reel bearing drag (7 to 11 in.-lb) should be checked more often on units with the grooming reel kit. The drive belt and clutch require removal for drag measurement and adjustment.

Cleaning

Hose off the grooming reel after use. Do not direct the water stream directly at the groomer bearing seals. Do not permit the grooming reel to stand in water so that the components rust.

Lubrication

Lubricate the grooming reel shaft bearings with a hand pump or grease gun (2 or 3 pumps maximum) (Fig. 19). Do not over grease as excess grease may cause seal failure.

Note: When lubricating the main reel bearings, do not over lubricate because excess grease can work its way into the grooming reel clutch and drive belt mechanism.

Blade Inspection

Inspect grooming reel blades frequently for damage and wear. Bent blades may be straightened with a pliers. Worn blades can be replaced or the grooming reel shaft reversed to put the sharpest edge of the blade forward (Fig. 22). When inspecting the blades, check to see that the right and left blade shaft end nuts are tight.

Note: Because the groomer may introduce more debris (i.e., dirt and sand) into the cutting unit than what the reel would normally be exposed, the bedknife and main reel should be checked for wear more frequently. This is especially important in sandy soil and/or when the groomer is set for penetration.

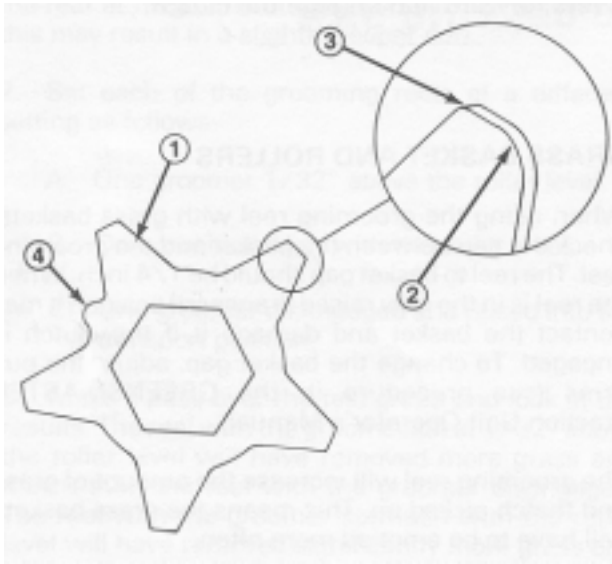

Figure 22

- | | |
|------------------------|------------------|
| 1. Grooming blade | 3. Sharp edge |
| 2. Dull (rounded edge) | 4. Location mark |

Grooming Reel Replacement

The grooming reel can be removed in order to replace individual blades, replace the entire shaft, or to reverse the shaft so that the sharpest edge of the blades is forward. Remove and replace the grooming reel shaft using the following procedure:

1. Remove the left side grooming reel housing cover (Fig. 17). Remove the drive belt by loosening the idler pulley (Fig. 15).
2. Remove the grooming reel shaft drive pulley (left hand thread) using an allen wrench (Fig. 10). Then remove the locknut securing the grooming reel to the right bearing housing bracket.
3. Remove the right side grooming reel housing bearing bracket by unfastening the three bolts and nuts (Fig. 11). Remove the grooming reel shaft.
4. Assemble the shaft in reverse order. Using the location marks on each blade as a guide, assemble each blade so the location mark is offset one flat on the hexagonal shaft.

Note: The location marks on each blade are offset so they can be used to achieve proper grooming reel setup. Stack the blades and match the location marks before installing them on the groomer reel shaft.

Torque the drive pulley and locknut (left hand thread) to 29–35 ft–lb (Fig. 10). Check drive belt tension. There should be 1/4 inch deflection when a force of 5–10 lb is applied midway between the drive and driven pulleys

(Fig. 15). To adjust belt tension, loosen the backside idler pivot screw and pivot the idler to achieve proper tension. Torque the pivot screw to 7–10 ft–lb.

5. Using a hand pump grease gun, lubricate the grooming reel shaft bearings. Pump only 2–3 pumps maximum to avoid permanently damaging the grease seals.
6. Check grooming reel height/depth setting.

