



**Topdresser 1800**  
**Workman 3000/4000 Series**  
Model No. 44225—230000001 and Up

## Parts Catalog

### Ordering Replacement Parts

To order replacement parts, please supply: the part number, the quantity, and the description of each part desired.

### Understanding Reference Numbers

Each identified part in an illustration has a reference number. The reference number for a part also appears in the parts list, along with other information about the part.

This catalog uses two special reference number formats, one to indicate parts in a service assembly and another to indicate the quantity of a given part in an illustration.

### Service Assembly Reference Numbers

Parts in service assemblies have reference numbers in the form **a:b**. The **a** represents the reference number of the entire service assembly and the **b** represents a sequential number unique to each part within the service assembly.

For example, a wheel assembly might be identified by reference number **6**, the tire by **6:1**, the valve by **6:2**, and the wheel by **6:3**. When you order the assembly identified by reference number **6**, you receive all parts identified by reference numbers **6:1**, **6:2**, and **6:3**. However, you may also order any part individually.

Reference numbers of this type appear in illustrations and in part lists.

### Reference Numbers Indicating Quantity

In an illustration, if a reference number indicates more than one part, the reference number has the form **nX y**. The **n** represents the quantity of the part, the **X** is the multiplication symbol, and the **y** represents the reference number.

For example, in an illustration, the reference number **2X 37** means that two of the parts identified by reference number **37** are indicated.

## Contents

<b>Description</b>	<b>Page</b>	<b>Description</b>	<b>Page</b>
Base Assembly .....	3	Hopper Assembly .....	7
Slider Bed and Roller Assembly .....	4	Gate Slide and Brush Guard Assembly .....	8
Gate Assembly .....	5	Chain, Sprocket and Guard Assembly .....	9
Brush and Motor Assembly .....	6		

## Accessories

<b>Description</b>	<b>Model / Part No.</b>	<b>Description</b>	<b>Model / Part No.</b>
Lift Bracket Assembly .....	92-4453	Jack Stands .....	Contact Distributor

## Part Description Abbreviations

Part descriptions in this catalog may include the following abbreviations.

<b>Abbreviation</b>	<b>Meaning</b>	<b>Abbreviation</b>	<b>Meaning</b>
AR .....	as required	HYD .....	hydraulic
ASM .....	assembly	INC .....	incorporated
CARR .....	carriage	LH .....	left hand
DEG .....	degrees	NI .....	nylon insert
FH .....	flat head	PPH .....	Phillips pan head
GA .....	gauge	PTH .....	Phillips truss head
HF .....	hex flange	PTO .....	power take off
HH .....	hex head	RH .....	right hand
HHF .....	hex head flange	SFH .....	slotted fillister head
HLH .....	hex lag head	SHH .....	slotted hex head
HJ .....	hex jam	SQH .....	square head
HOC .....	height-of-cut	SHWH .....	slotted hex washer head
HS .....	hex socket	SPH .....	slotted pan head
HSBH .....	hex socket button head	SRH .....	slotted round head
HSFH .....	hex socket flat head	STD .....	standard
HSH .....	hex socket head	TAP .....	self tapping
HWH .....	hex washer head	TTH .....	Torx truss head
HWHTF .....	hex washer head thread forming	WH .....	wing head

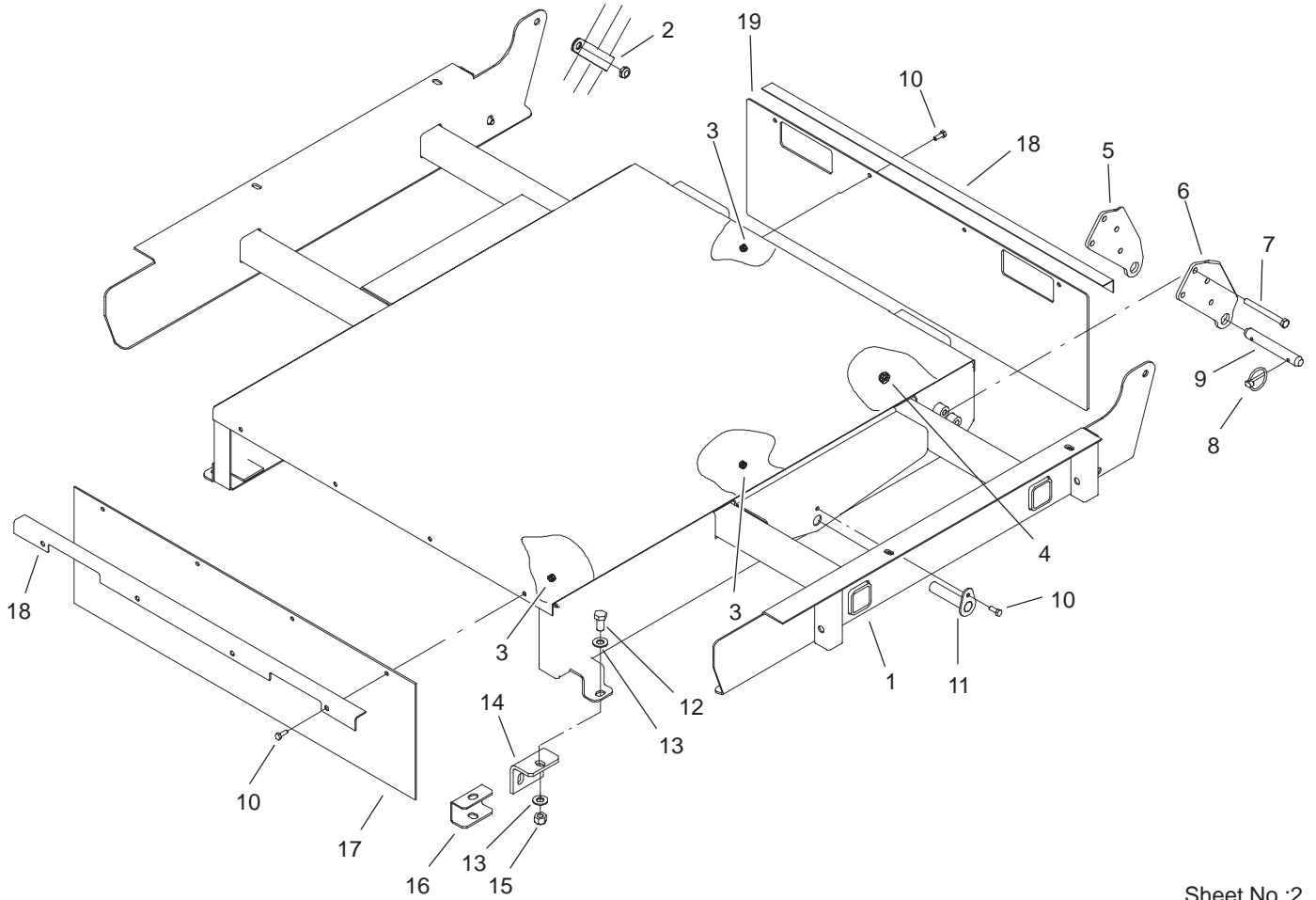

Sheet No.:2

## Base Assembly

Ref. No.	Part No.	Qty.	Description
1	106-7857-01	1	Base ASM
2	100-1424	1	Clamp-R
3	3296-42	10	Nut-Lock, NI
4	3296-44	8	Nut-Lock, NI
5	93-9721	2	Bracket-Pivot, Long RH
6	93-9720	2	Bracket-Pivot, Long LH
7	323-42	8	Screw-HH
8	92-1298	4	Pin-Lynch
9	92-1233	2	Pin-Clevis
10	321-4	10	Screw-HH
11	92-4459	2	Pin-Cylinder
12	325-4	4	Screw-HH
13	3256-26	8	Washer-Flat
14	92-2667-03	2	Bracket-Attachment, Mount
15	3296-25	4	Nut-Lock, NI
16	92-4576	2	Spacer-Mount
17	100-1423	1	Cover-Rubber
18	106-7859	2	Clamp-Rubber
19	106-7860	1	Cover-Rubber

Ref. No.	Part No.	Qty.	Description

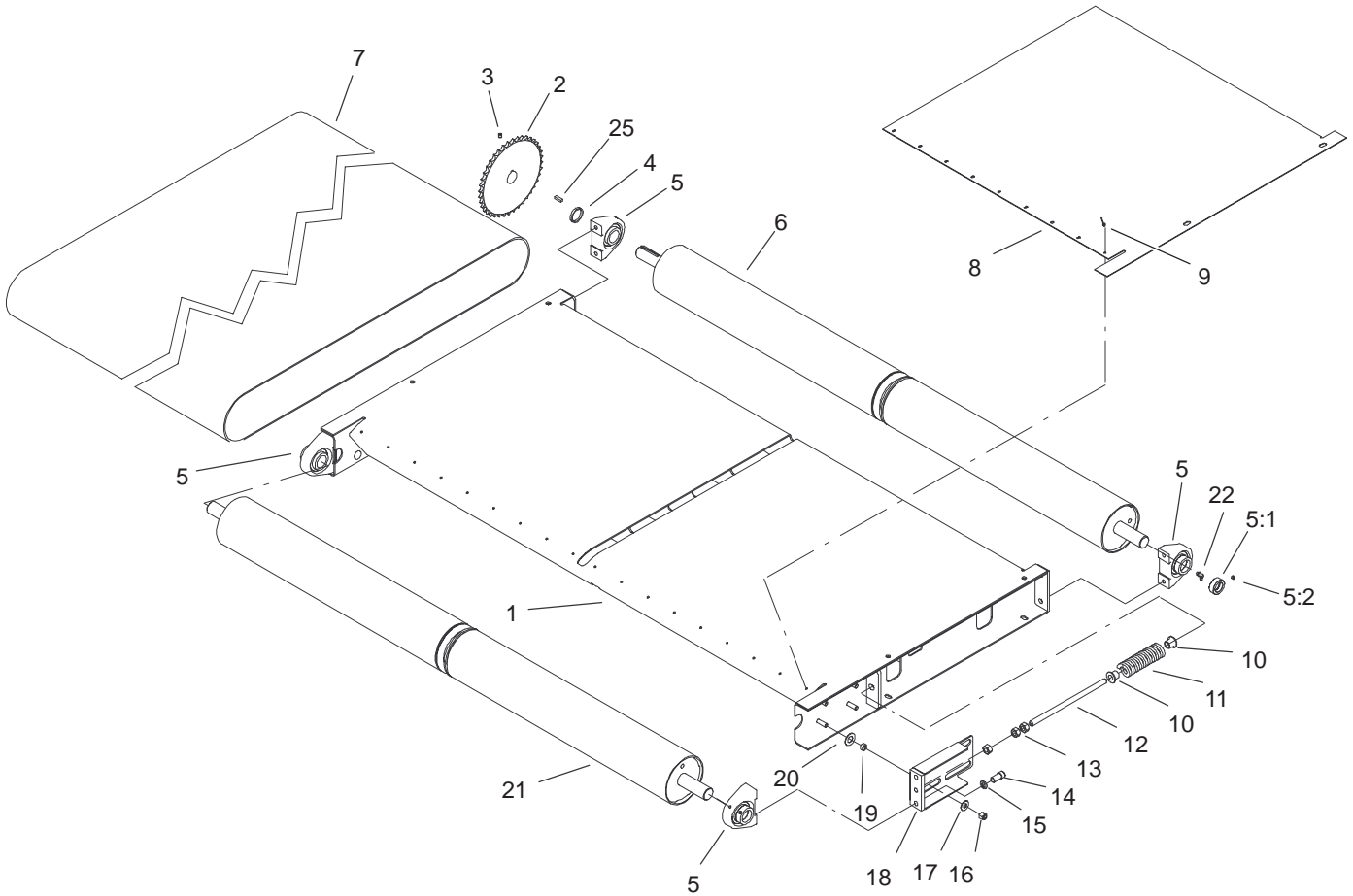

Sheet No.:3

# Slider Bed and Roller Assembly

Ref. No.	Part No.	Qty.	Description	Ref. No.	Part No.	Qty.	Description
1	99-0038-01	1	Frame-Bed, Slider				
2	99-0166-03	1	Sprocket-Driven				
3	3246-3	2	Screw-HS				
4	99-0017-01	1	Spacer-Sprocket				
5	99-0158	4	Bearing-Base, Tapped				
5:1	251-246	1	Collar W/Set Screws				
5:2	3245-35	1	Screw-HS				
6	99-0046	1	Roller-Rear				
7	100-1425	1	Belt Kit				
8	99-0047	2	Plate-W ear				
9	3269-28	18	Rivet-Pop				
10	100-1414	4	Holder-Spring				
11	99-0163	2	Spring-Compression				
12	99-01 18	2	Pin-Spring				
13	3217-9	6	Nut-HH				
14	100-1438	8	Screw-Socket Head, Torx				
15	3253-6	8	Washer-Lock				
16	3296-39	8	Nut-Lock, NI				
17	3256-4	8	Washer-Flat				
18	99-0050-01	2	Spring Plate ASM				
19	99-0052	8	Washer-Slide				
20	100-1401	8	Spacer-Slide, Spring				
21	99-0044	1	Roller-Front				
22	302-60	4	Fitting-Grease				
25	10-7070	1	Key-Square				

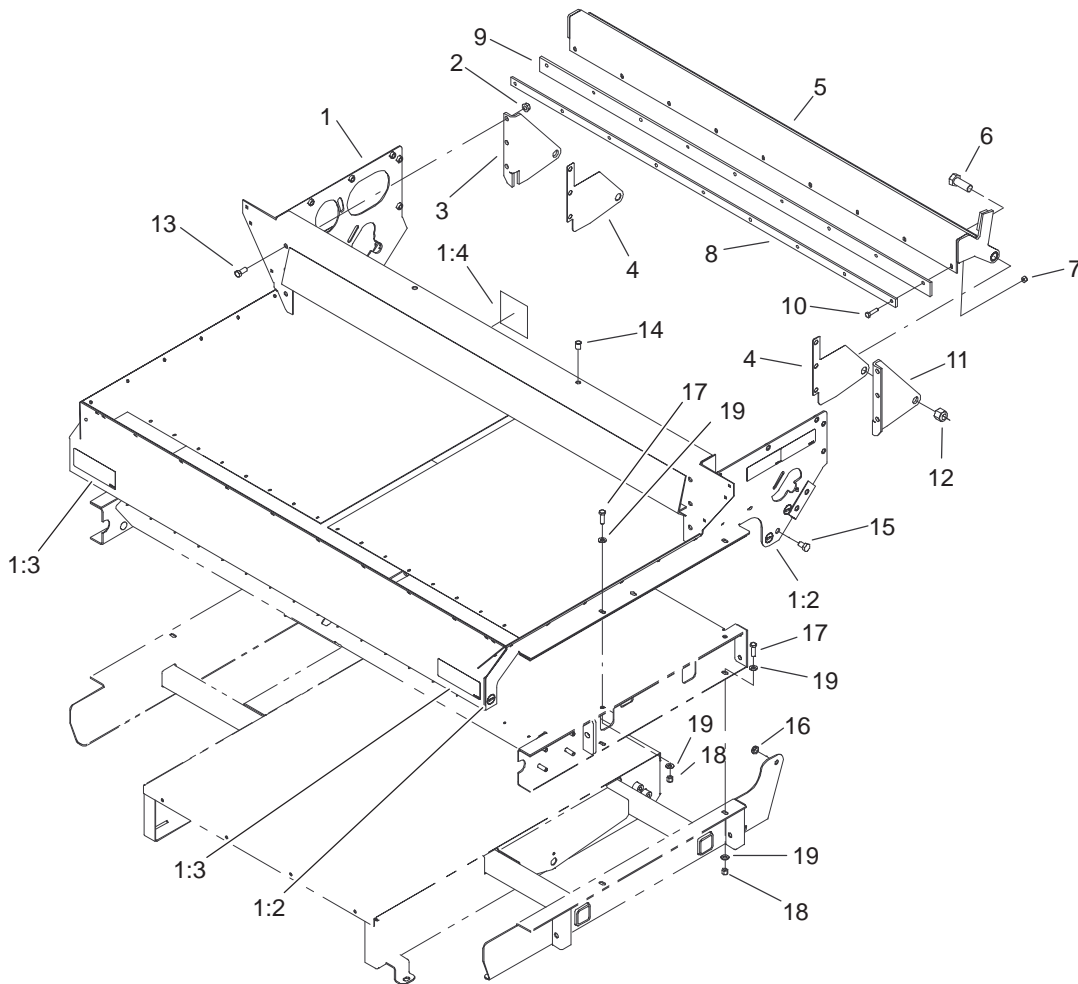

Sheet No.:4

## Gate Assembly

Ref. No.	Part No.	Qty.	Description
1	100-1435	1	Hopper Frame ASM
1:2	58-6520	4	Decal-Grease
1:3	93-9092	2	Decal-W arning
1:4	105-4586	1	Decal-Shield
2	32128-37	6	Nut-HF
3	99-0079-01	1	Bracket-Gate Pivot, RH
4	99-01 17	2	Wareplate-Gate
5	99-0068-01	1	Gate ASM
6	328-24	2	Screw-HH
7	3296-29	9	Nut-Lock, NI
8	99-0089-01	1	Plate-Backing
9	99-0074	1	Seal-Gate
10	322-6	9	Screw-HH
11	99-0078-01	1	Bracket-Gate Pivot, LH
12	3296-51	2	Nut-Lock, NI
13	324-4	6	Screw-HH
14	32148-9	2	Insert-Nut
15	325-2	2	Screw-HH
16	3296-45	2	Nut-Lock, NI
17	323-7	8	Screw-HH
18	3296-39	8	Nut-Lock, NI
19	3256-24	12	Washer-Flat

Ref. No.	Part No.	Qty.	Description

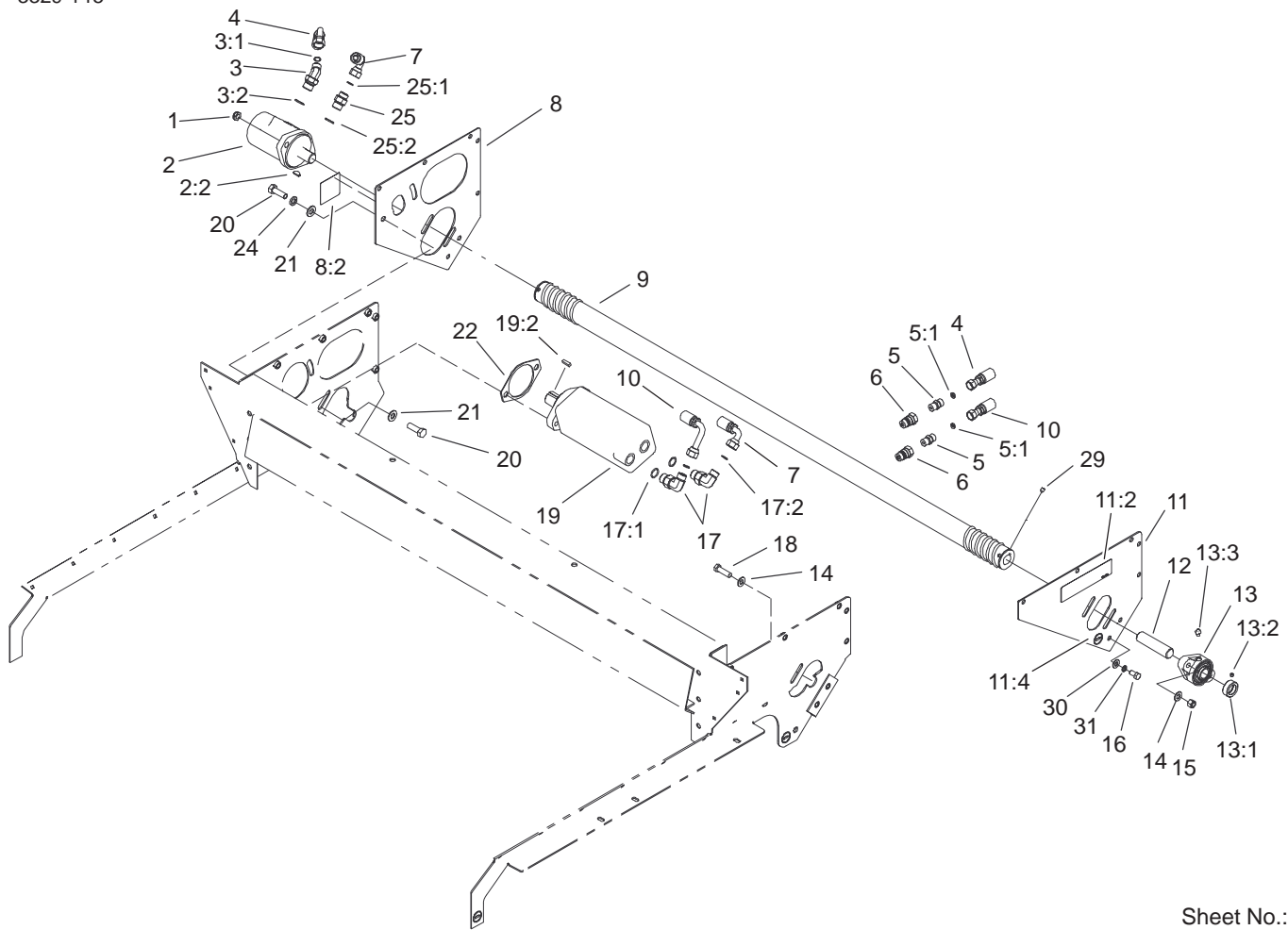

Sheet No.:5

## Brush and Motor Assembly

Ref. No.	Part No.	Qty.	Description
1	3296-45	2	Nut-Lock, NI
2	99-0156	1	Motor-HYD
*2:1	100-1446	1	Seal Kit
2:2	3257-43	1	Key-W oodruff
3	340-89	1	Fitting-HYD, 45°
3:1	237-30	1	O-Ring
3:2	237-80	1	O-Ring
4	99-0191	1	Hose-Pressure
5	340-12	2	Fitting-Straight
5:1	237-22	1	O-Ring
6	92-2672	2	Coupling-HYD
7	99-0177	1	Hose-HYD
8	100-1431	1	RH Motor Brace ASM
8:2	105-4586	1	Decal-Shield
9	99-0162	1	Brush
10	99-0192	1	Hose-Return
11	100-1430	1	LH Motor Brace ASM
11:2	106-7750	1	Decal-Danger
11:4	58-6520	1	Decal-Grease
12	99-0041	1	Shaft-Brush
13	99-0160	1	Bearing
13:1	251-249	1	Collar W/Set Screws
13:2	3245-35	1	Screw-HS
13:3	302-2	1	Fitting-Grease
14	3256-25	4	Washer-Flat
15	3296-48	2	Nut-Lock NI

Ref. No.	Part No.	Qty.	Description
16	323-4	4	Screw-HH
17	340-105	2	Fitting-HYD, 90°
17:1	237-80	1	O-Ring
17:2	237-30	1	O-Ring
18	324-6	2	Screw-HH
19	99-0155	1	HYD Motor Conveyor ASM
*19:1	100-1447	1	Seal Kit
19:2	10-7070	1	Key-Square
20	325-6	4	Screw-HH
21	3256-26	4	Washer-Flat
22	99-0116	1	Plate-Spacer
24	3253-7	2	Washer-Lock
25	340-6	1	Fitting-HYD, Straight
25:1	237-30	1	O-Ring
25:2	237-80	1	O-Ring
29	3246-3	4	Screw-HS
30	3256-24	4	Washer-Flat
31	3253-21	4	Washer-Lock

\* Not illustrated

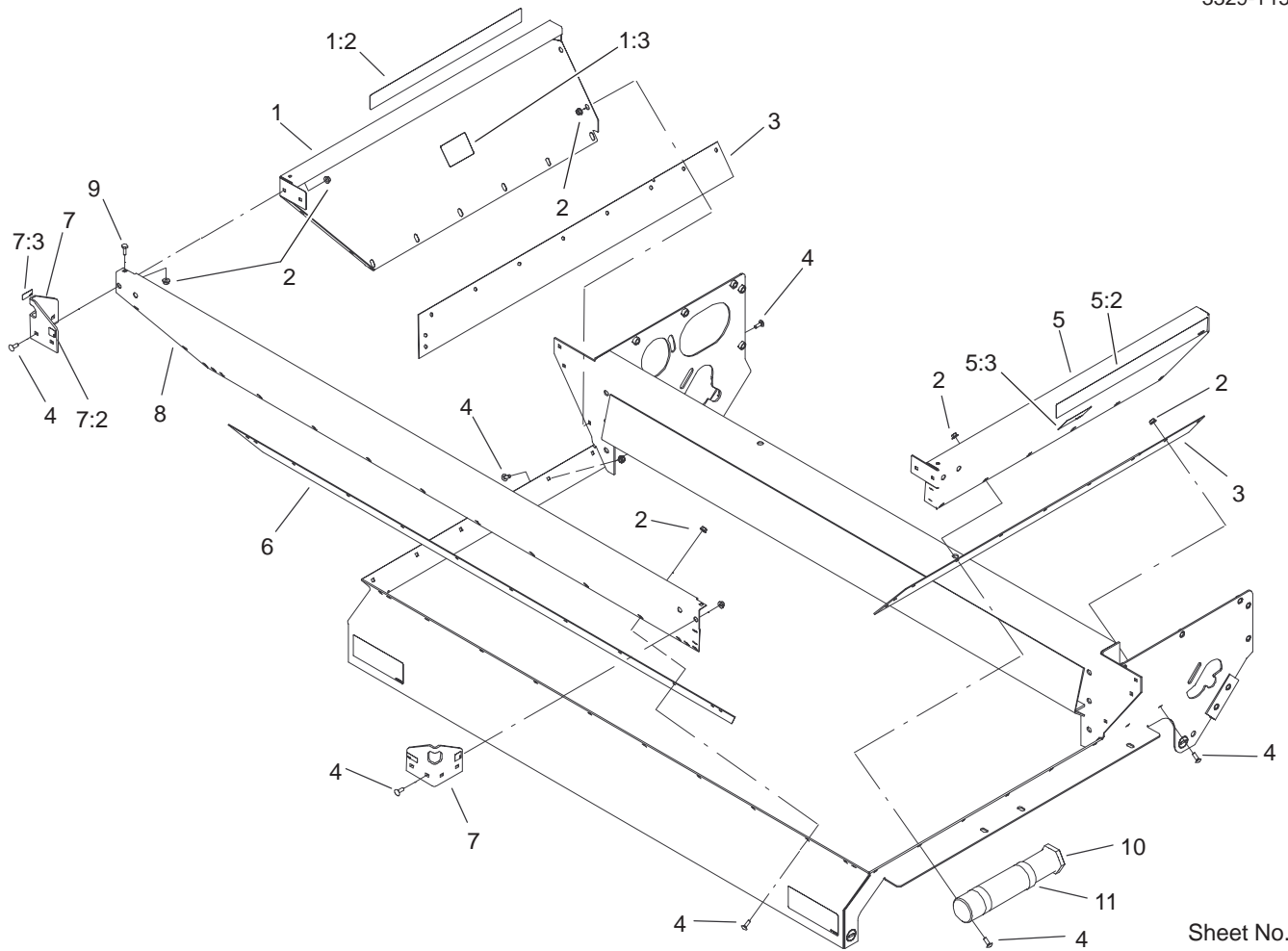

Sheet No.:6

## Hopper Assembly

Ref. No.	Part No.	Qty.	Description
1	100-1434	1	RH Hopper Panel ASM
1:2	99-0013	1	Decal-1800, Topdresser
1:3	94-1235	1	Decal-Capacity
2	32128-33	44	Nut-HF
3	99-0142	2	Seal-Sand, Side
4	3229-25	40	Screw-CARR
5	100-1433	1	LH Hopper Panel ASM
5:2	99-0013	1	Decal-1800, Topdresser
5:3	94-1235	1	Decal-Capacity
6	99-0143	1	Seal-Sand, Front
7	100-1428	2	Front Lift Eye ASM
7:2	93-9084	1	Decal-Point, Lift
7:3	93-9529	1	Decal-Value, Kg
8	99-0020	1	Panel-Hopper, Front
9	321-4	4	Screw-HH
10	74-0720	1	Tube-Manual
11	2412-133	2	R-Clamp

Ref. No.	Part No.	Qty.	Description

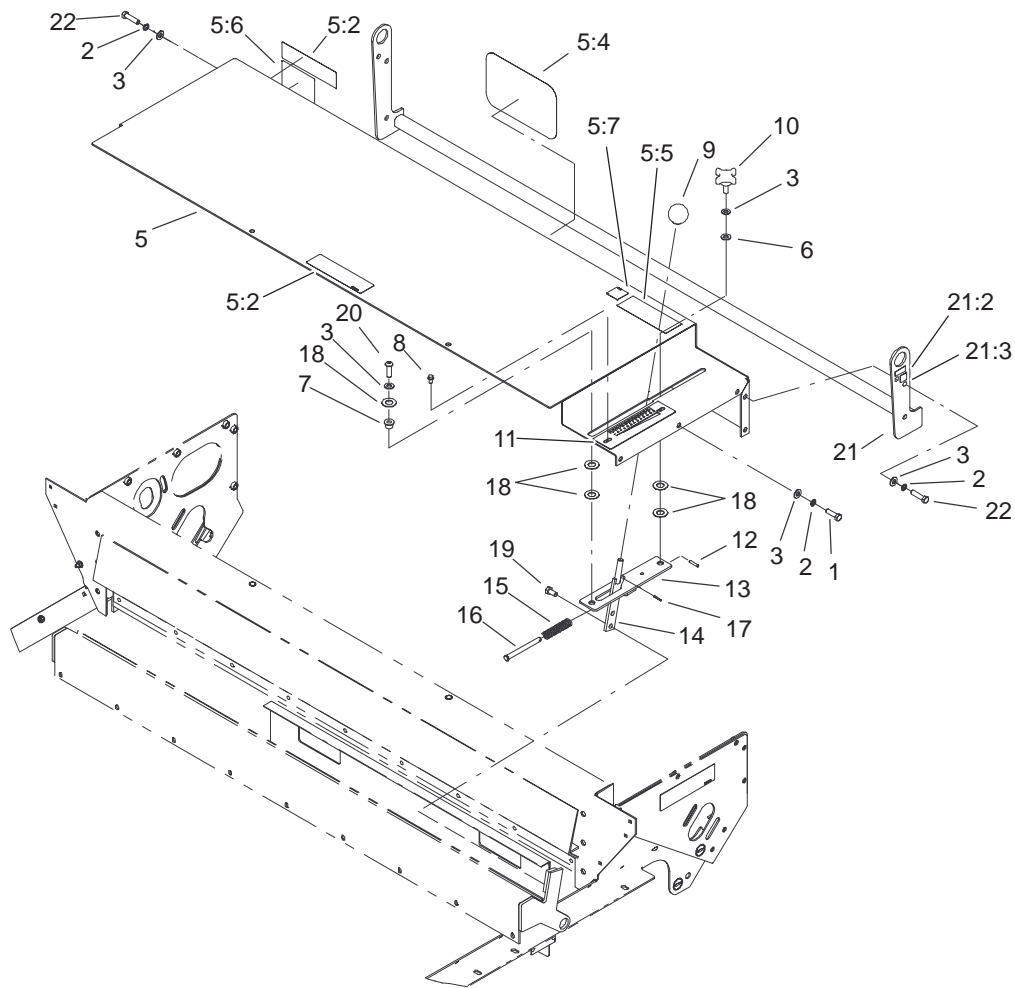

Sheet No.:7

## Gate Slide and Brush Guard Assembly

Ref. No.	Part No.	Qty.	Description
1	323-7	6	Screw-HH
2	3253-21	12	Washer-Lock
3	3256-24	13	Washer-Flat
5	100-1432	1	Brush Guard ASM
5:2	106-7750	2	Decal-Danger
5:4	92-1242	1	Decal-T oro
5:5	105-0707	1	Decal-Ansi
5:6	105-0708	1	Decal-Danger
5:7	98-31 14	1	Decal-W arning, Belt Drive, Ce
6	95-4896	1	Washer-Nylon
7	256-259	1	Bushing-Flange
8	93-6083	2	Screw-HWH
9	233-48	1	Knob
10	100-1449	1	Knob
11	100-1416	1	Plate-Gate
12	32121-45	1	Pin-Spring
13	99-0073-03	1	Slide Block Plate ASM
14	100-1406-03	1	Gate Handle ASM
15	100-1448	1	Spring-Gate
16	100-1413	1	Pin-Clevis
17	32121-40	1	Pin-Spring
18	99-0052	5	Washer-Slide
19	323-4	2	Screw-HH
20	3274-63	1	Screw-Socket, Button Head

Ref. No.	Part No.	Qty.	Description
21	106-0281	1	Bumper ASM
21:2	93-9529	2	Decal-V alue, Kg
21:3	93-9084	2	Decal-Point, Lift
22	323-8	6	Screw-HH
23	105-0698	1	Decal-Caution



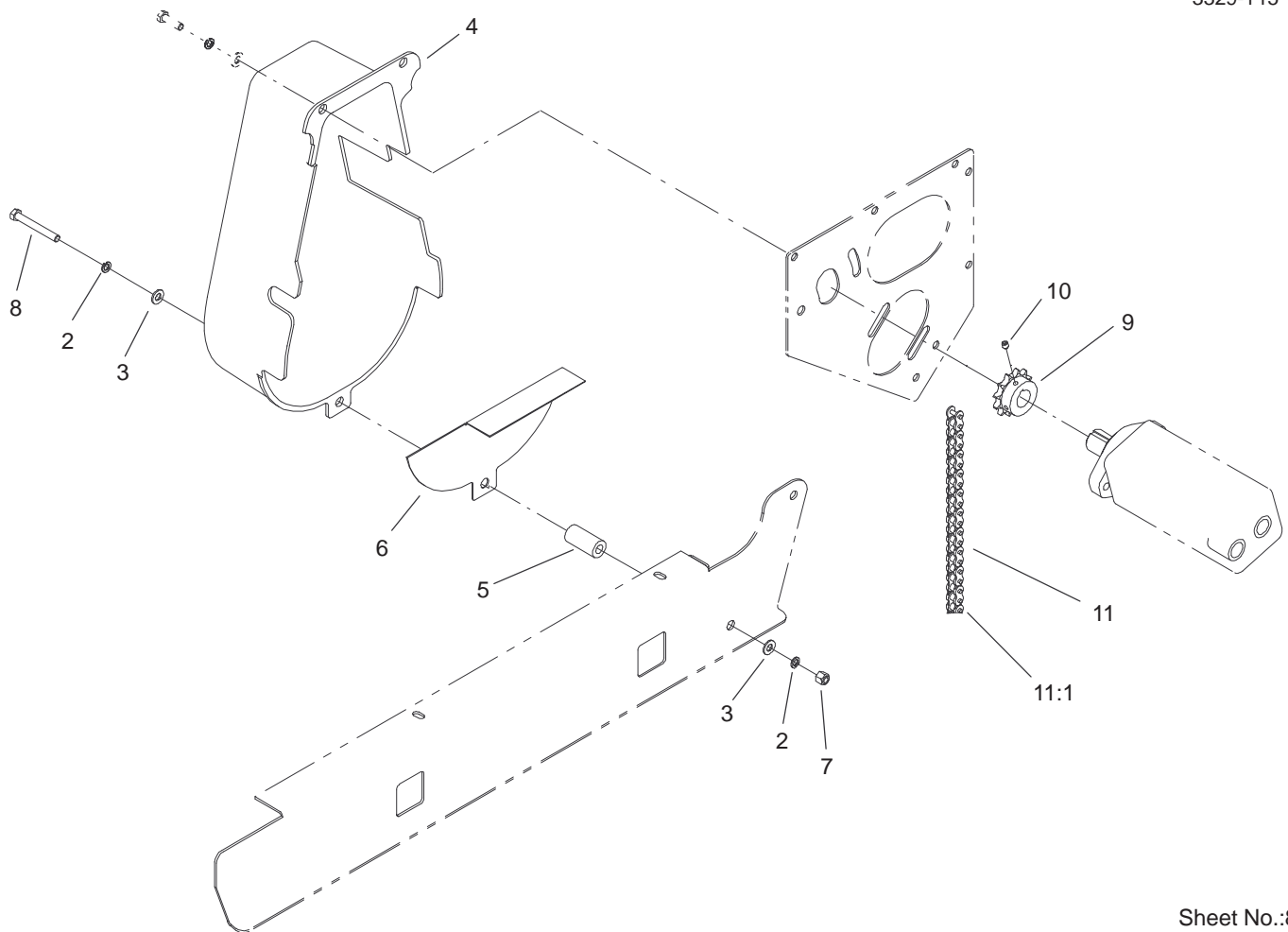

Sheet No.:8

## Chain, Sprocket and Guard Assembly

Ref. No.	Part No.	Qty.	Description
2	3253-21	2	Washer-Lock
3	3256-24	2	Washer-Flat
4	99-0171	1	Guard-Chain (Plastic)
5	100-1442	1	Spacer-Guard
6	106-2326-03	1	Guard-Finger
7	3296-39	1	Nut-Lock, NI
8	323-14	1	Screw-HH
9	99-0165-03	1	Sprocket-Drive
10	3246-3	2	Screw-HS
11	99-0164	1	Chain-Roller
11:1	2710-16	1	Link-Chain

Ref. No.	Part No.	Qty.	Description

# Maintenance Record

Date								

# Maintenance Record

Date								

