



Greensmaster[®] 3100
2 Wheel Drive Traction Unit
Model No. 04356—230000001 and Up

Parts Catalog

Ordering Replacement Parts

To order replacement parts, please supply: the part number, the quantity, and the description of each part desired.

Understanding Reference Numbers

Each identified part in an illustration has a reference number. The reference number for a part also appears in the parts list, along with other information about the part.

This catalog uses two special reference number formats, one to indicate parts in a service assembly and another to indicate the quantity of a given part in an illustration.

Service Assembly Reference Numbers

Parts in service assemblies have reference numbers in the form **a:b**. The **a** represents the reference number of the entire service assembly and the **b** represents a sequential number unique to each part within the service assembly.

For example, a wheel assembly might be identified by reference number **6**, the tire by **6:1**, the valve by **6:2**, and the wheel by **6:3**. When you order the assembly identified by reference number **6**, you receive all parts identified by reference numbers **6:1**, **6:2**, and **6:3**. However, you may also order any part individually.

Reference numbers of this type appear in illustrations and in part lists.

Reference Numbers Indicating Quantity

In an illustration, if a reference number indicates more than one part, the reference number has the form **nX y**. The **n** represents the quantity of the part, the **X** is the multiplication symbol, and the **y** represents the reference number.

For example, in an illustration, the reference number **2X 37** means that two of the parts identified by reference number **37** are indicated.

Contents

Description	Page	Description	Page
Control Pedal Assembly	4	Hydraulic Schematic	41
Control Pedal Assembly (Continued)	5	Cylinder Assembly	
Traction Controls Assembly	6	Briggs and Stratton Model 350447-1331-E1	42
Front Wheel and Brake Assembly	7	Crankshaft Assembly	
Hydraulic Drive Motor Assembly No. 92-9199 .	8	Briggs and Stratton Model 350447-1331-E1	43
Steering Arm Assembly	9	Cylinder Head Assembly	
Power Steering Valve Assembly No. 92-8690 .	10	Briggs and Stratton Model 350447-1331-E1	44
Right Hand Pull Frame Assembly	11	Cylinder Head Assembly	
Hydraulic Cylinder Assembly No. 105-3822 ...	12	Briggs and Stratton Model 350447-1331-E1	45
Left Hand Pull Frame Assembly	13	Intake Manifold and Rocker Cover Assembly	
Rear Pull Frame Assembly	15	Briggs and Stratton Model 350447-1331-E1	46
Hydraulic Cylinder Assembly No. 105-3823 ...	17	Carburetor Assembly	
Seat Assembly	18	Briggs and Stratton Model 350447-1331-E1	47
Control Valve Installation Assembly	20	Governor Assembly	
Control Valve Assembly No. 105-3800	22	Briggs and Stratton Model 350447-1331-E1	48
Section 1 Assembly No. 105-3801	23	Alternator Assembly	
Section 2 Assembly No. 105-3802	24	Briggs and Stratton Model 350447-1331-E1	49
Section 3 Assembly No. 105-3803	25	Fuel Pump, Oil Pump and Dipstick Assembly	
Section 4 Assembly No. 105-3804	26	Briggs and Stratton Model 350447-1331-E1	50
Section 5 Assembly No. 93-1386	27	Air Cleaner Assembly	
Engine Installation Assembly	28	Briggs and Stratton Model 350447-1331-E1	51
Hydraulic Pump Installation Assembly	29	Blower Housing Assembly	
Hydraulic Pump Assembly No. 92-9764	30	Briggs and Stratton Model 350447-1331-E1	52
Frame Assembly	31	Flywheel Assembly	
Rear Wheel Assembly	32	Briggs and Stratton Model 350447-1331-E1	53
Hydraulic Cylinder Assembly No. 83-2330	33	Starter Assembly	
Control Panel Assembly	34	Briggs and Stratton Model 350447-1331-E1	54
Hydraulic Reservoir Assembly	35	Starter Assembly	
Fuel Tank Assembly	36	Briggs and Stratton Model 350447-1331-E1	55
Reel Motor Installation Assembly	37	Gasket Assembly	
Hydraulic Motor Assembly No. 105-9770	38	Briggs and Stratton Model 350447-1331-E1	56
Electrical Schematic	39	Carburetor Overhaul Kit Assembly	
Grass Basket Assembly and		Briggs and Stratton Model 350447-1331-E1	57
Miscellaneous Parts	40	Special Tools	58

Accessories

Description	Model / Part No.	Description	Model / Part No.
Individual Reel Shut Off Kit	28-2150	8 Blade, 4 Bolt (Heavy Duty) Cutting Unit	04404
Basket Reinforcement Kit	26-0900	8 Blade, 4 Bolt Cutting Unit	04408
Thatching Reels	04493	11 Blade, 4 Bolt Cutting Unit	04406
Variable Speed Kit	04422	8 Blade, SPA Cutting Unit	04468
Traction Tire	231-124	11 Blade, SPA Cutting Unit	04450
Armrests	30707	8 Blade, 4 Bolt Cutting Unit	04470
Spiker	04494	11 Blade, 4 Bolt Cutting Unit	04471
Tri-Roller	04495	8 Blade, SPA Cutting Unit	04472
Backlapping Kit	92-9656	11 Blade, SPA Cutting Unit	04473
Backlap Kit - 2 Speed, 3 Position	94-1870	Light Kit	105-3848

Part Description Abbreviations

Part descriptions in this catalog may include the following abbreviations.

Abbreviation	Meaning	Abbreviation	Meaning
AR	as required	HYD	hydraulic
ASM	assembly	INC	incorporated
CARR	carriage	LH	left hand
DEG	degrees	NI	nylon insert
FH	flat head	PPH	Phillips pan head
GA	gauge	PTH	Phillips truss head
HF	hex flange	PTO	power take off
HH	hex head	RH	right hand
HHF	hex head flange	SFH	slotted fillister head
HLH	hex lag head	SHH	slotted hex head
HJ	hex jam	SQH	square head
HOC	height-of-cut	SHWH	slotted hex washer head
HS	hex socket	SPH	slotted pan head
HSBH	hex socket button head	SRH	slotted round head
HSFH	hex socket flat head	STD	standard
HSH	hex socket head	TAP	self tapping
HWH	hex washer head	TTH	Torx truss head
HWHTF	hex washer head thread forming	WH	wing head

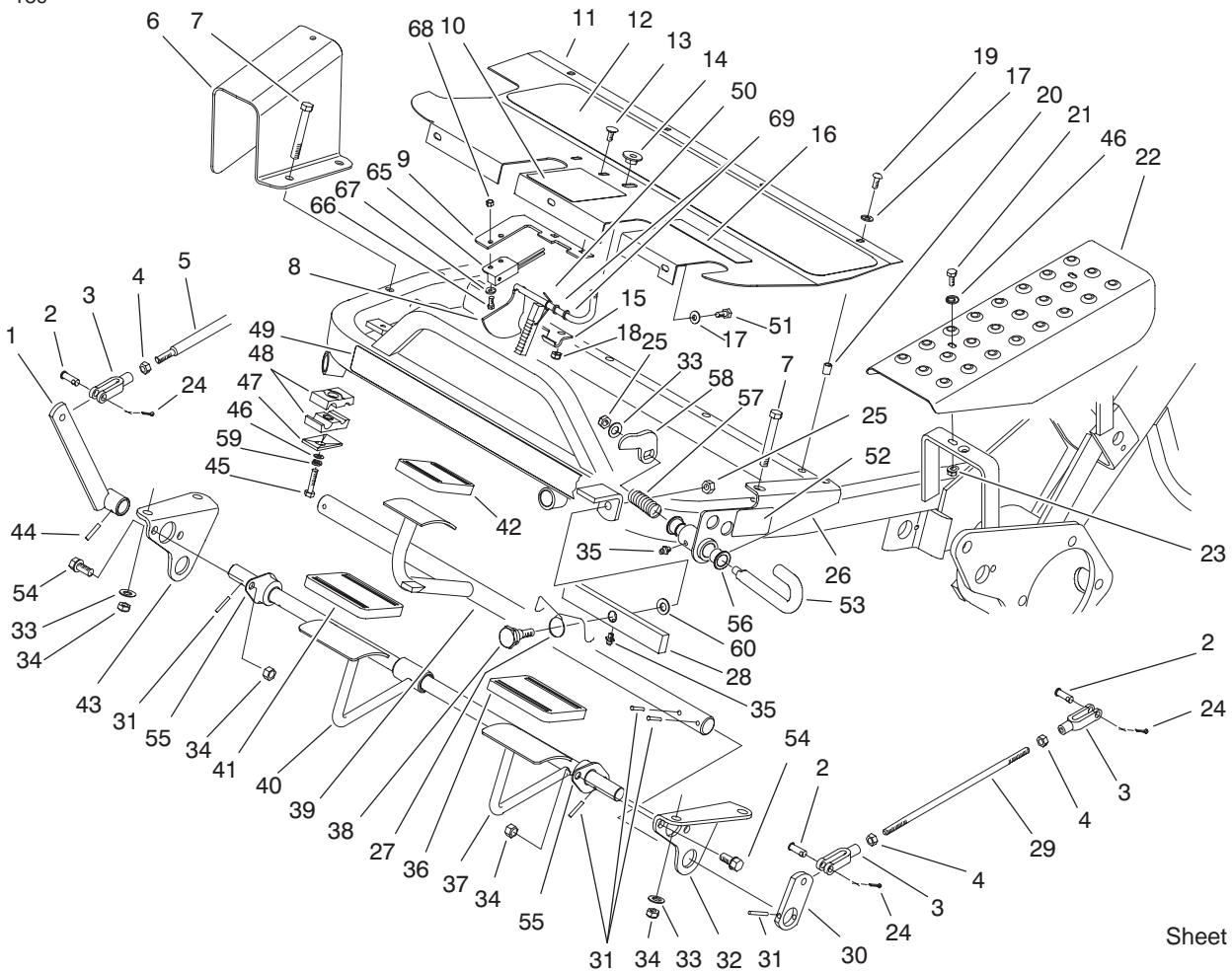

Sheet No.: 2

Control Pedal Assembly

Ref. No.	Part No.	Qty.	Description
1	49-6200-01	1	Lever-Cutting
2	283-61	5	Pin-Yoke
3	282-2	5	Yoke
4	3220-2	5	Nut
5	49-5430	1	Rod-Control
6	49-6110-01	1	Guard
7	323-13	4	Screw-HH
8	100-9819	1	Latch ASM
9	100-9821	1	Plate-Switch, Reed
10	93-8062	1	Decal-Brake, Parking
11	83-0640-01	1	Plate-Footrest
12	49-6120	1	Pad-Footrest
13	3229-11	2	Screw-CARR
14	32141-111	1	Nut-Adjusting
15	95-1629	1	Hinge-Lower
16	93-8075	1	Decal-Mow/Lift
17	3256-1	7	Washer-Flat
18	3296-16	2	Nut-Lock, NI
19	3274-31	4	Screw-HSBH
20	32148-6	8	Insert-Nut
21	321-4	2	Screw-HH
22	83-0200-01	1	Plate-Cover, LH
23	32128-33	2	Nut-HF
24	3272-6	5	Pin-Cotter
25	3296-39	2	Nut-Lock, NI
26	93-9901-01	1	Bracket-Lockout, Mow

Ref. No.	Part No.	Qty.	Description
27	83-0080	1	Spring-Pivot, Lift
28	106-6396	1	Lift-Pivot
29	27-2270	2	Rod-Adjustment, Brake
30	10-8100-01	2	Strap-Shaft, Brake
31	32121-35	8	Pin-Roll
32	88-9640-01	1	Bracket-Lift Pivot, LH
33	3256-24	5	Washer-Flat
34	3296-59	8	Nut-Lock, NI
35	302-5	2	Fitting-Grease
36	93-7631	1	Pad-Foot, Lift
37	106-6395	1	Cutting Control Shaft ASM
38	83-2590	1	Bolt-Shoulder, Pivot
39	83-0160	1	Shaft-Brake
40	106-6394	1	Mow Pedal ASM
41	93-7630	1	Pad-Foot
42	93-7629	1	Pad-Foot, Brake
43	88-9630-01	1	Bracket-Lift Pivot, RH
44	32121-6	1	Pin-Roll
45	321-11	1	Screw-HH
46	3256-22	3	Washer-Flat
47	69-9760	1	Coverplate
48	56-7970	2	Clamp-Tube
49	88-9620	1	Decal-Gr3100
50	10-8140	1	Spring-Latch, Brake

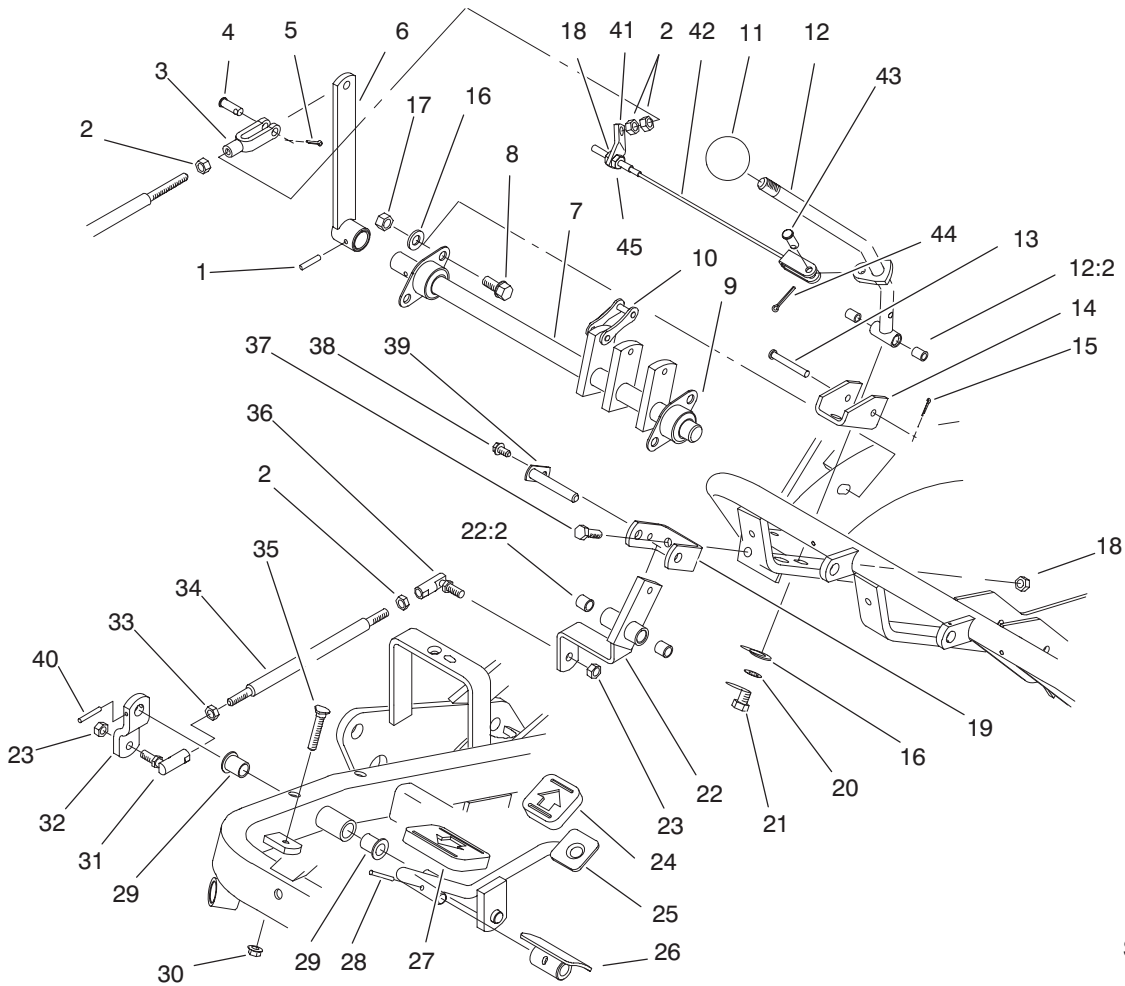

Sheet No.: 3

Traction Controls Assembly

Ref. No.	Part No.	Qty.	Description
1	32121-6	1	Pin-Roll
2	3220-2	4	Nut
3	282-2	1	Yoke
4	283-61	1	Pin-Yoke
5	3272-6	1	Pin-Cotter
6	47-5320-01	1	Lever
7	44-0870	1	Cam Shaft ASM
8	3234-1	4	Screw-HHF
9	27-2320	2	Bearing
10	57-6220	5	Link-Connecting
11	233-48	1	Knob
12	93-9934	1	Handle-Traction
12:2	256-251	2	Bushing
13	283-57	1	Pin
14	49-6220	1	Bracket-Arm, Control
15	3272-4	1	Pin-Cotter
16	3256-24	6	Washer-Flat
17	3296-59	4	Nut-Lock, NI
18	3296-29	3	Nut-Lock, NI
19	49-6250	1	Bracket-Pivot
20	3254-6	2	Washer-Lock, Internal
21	3211-2	2	Screw-HH
22	49-6260	1	Pivot ASM
22:2	256-2	2	Bushing
23	3296-4	2	Nut-Lock, NI
24	74-9110	1	Pad-Pedal, Reverse

Ref. No.	Part No.	Qty.	Description
25	83-0540-01	1	Traction Pedal ASM
26	49-6440-03	1	Pedal-Forward
27	74-9100	1	Pad-Pedal, Forward
28	32121-45	1	Pin-Spring
29	256-155	2	Bushing-Flange
30	32128-20	1	Nut-HF
31	2411-42	1	Joint-Ball, LH
32	83-0630	1	Arm-Pivot, Traction
33	3220-20	1	Nut-Jam
34	83-0580	1	Rod-Control, Traction
35	17-9420	1	Screw-Handle
36	2411-43	1	Joint-Ball
37	322-5	2	Screw-HH
38	12-3270	1	Screw
39	49-6290	1	Pivot Shaft ASM
40	32121-51	1	Pin-Roll
41	93-9936	1	Bracket-Return, Traction
42	93-9937	1	Traction Cable ASM
43	283-62	1	Pin-Clevis
44	3272-10	1	Pin-Cotter
45	3217-6	1	Nut-Hex

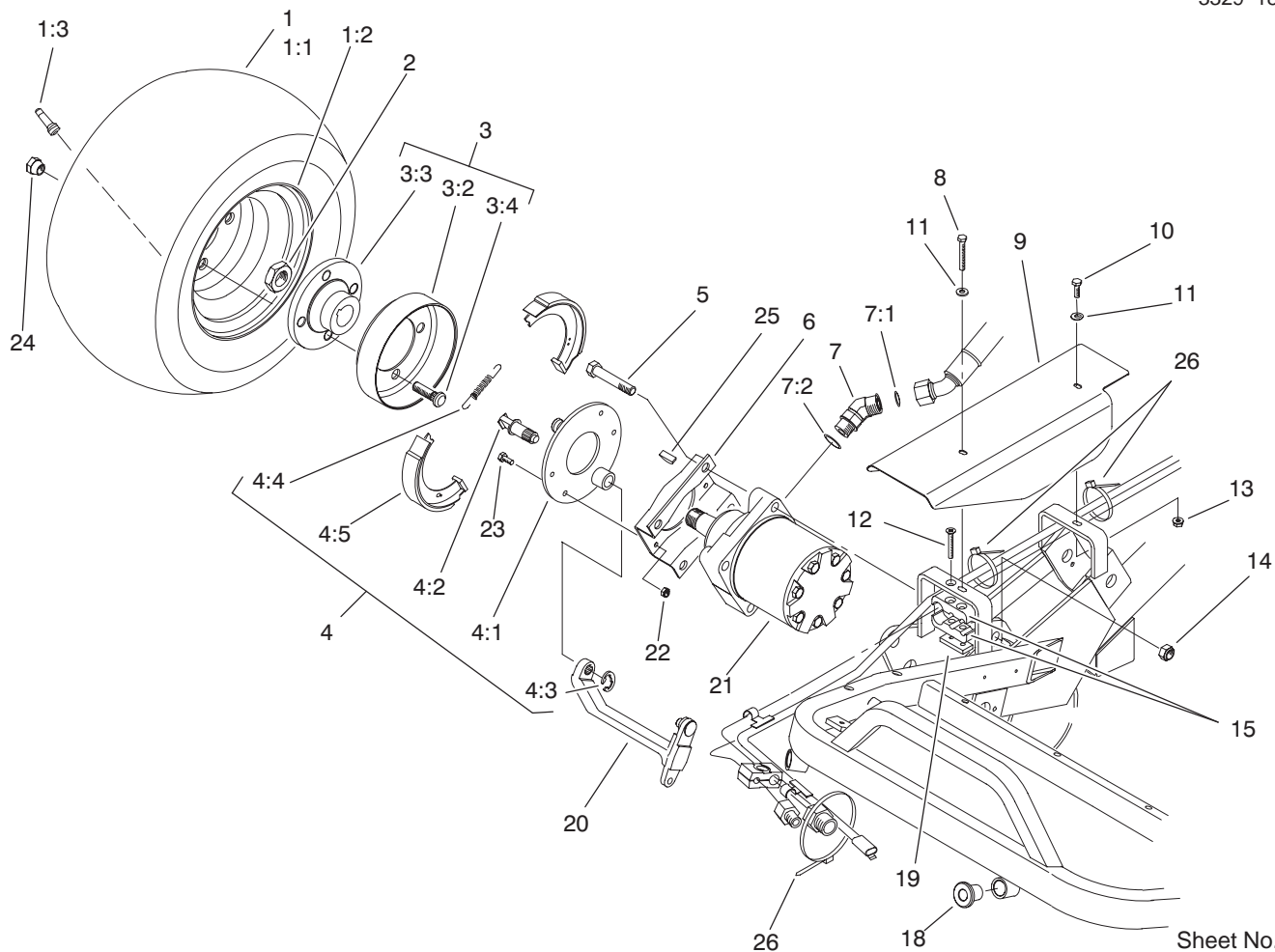

Sheet No.: 4

Front Wheel and Brake Assembly

Ref. No.	Part No.	Qty.	Description
☆1		2	Wheel And Tire ASM
1:1	28-3680	1	Tire
1:2	217-60	1	Rim
1:3	232-27	1	Stem-Valve
1:5	232-37	1	Tube
2	26-3790	2	Nut-Lock
3	10-6821	2	Brake Drum ASM
3:2	10-6850	1	Drum-Brake
3:3	10-6870-03	1	Hub-Wheel
3:4	85-6540	4	Stud-Drive
4	104-7705	2	Brake ASM
4:1	70-9870	1	Plate-Backing
4:2	104-7707	1	Shaft-Cam, Brake
4:3	104-7706	1	E-Ring-Bowed
4:4	70-9880	2	Spring-Return
4:5	70-9840	2	Shoe-Brake
5	325-11	8	Screw-HH
6	84-2000-03	2	Bracket-Brake
7	340-14	4	Fitting-HYD, 45°
7:1	237-65	1	O-Ring
7:2	237-80	1	O-Ring
8	321-11	1	Screw-HH
9	83-0190-01	1	Cover-RH
10	321-4	1	Screw-HH
11	3256-22	2	Washer-Flat
12	32108-100	1	Screw-FH

Ref. No.	Part No.	Qty.	Description
13	32128-33	1	Nut-HF
14	3296-23	8	Nut-Lock, NI
15	57-6140	2	Clamp-Tube, Half
18	83-1700	2	Bushing-Flange
19	83-1220	1	Plate-Clamp
20	93-2096	2	Lever-Brake
21	92-9199	2	Motor-Wheel, HYD
22	3296-42	8	Nut-Lock, NI
23	321-5	8	Screw-HH
24	242-50	8	Nut-Lug
25	3257-42	2	Key-Woodruff
26	3290-378	3	Tie-Cable

☆ Not serviced separately

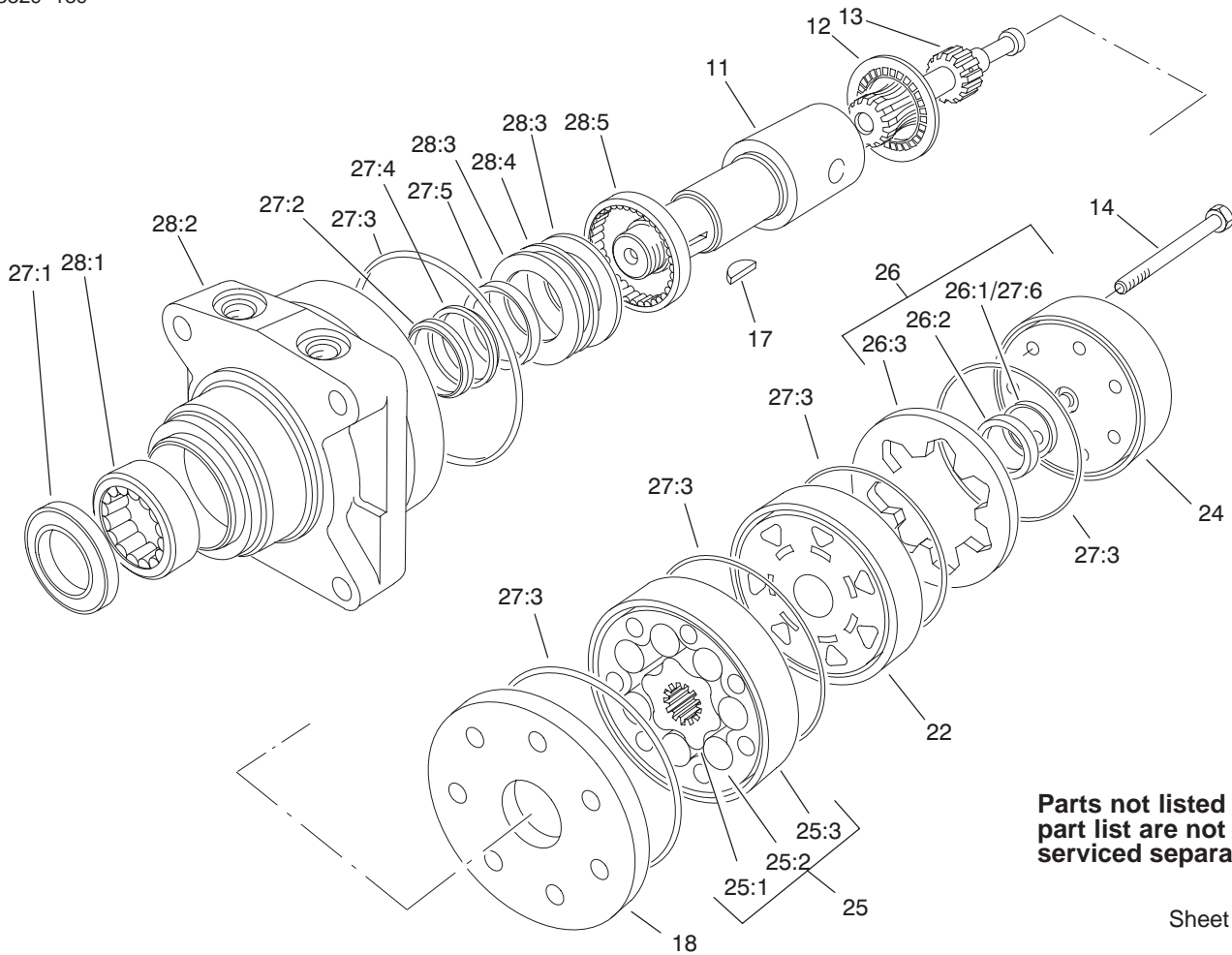

Sheet No.: A1
T-0983

Hydraulic Drive Motor Assembly No. 92-9199

Ref. No.	Part No.	Qty.	Description
11	76-0860	1	Shaft-Coupling
12	76-0850	1	Bearing-Thrust
13	92-9761	1	Link-Drive
14	92-9762	7	Screw-HH
17	3257-42	1	Key-Woodruff
18	76-0870	1	Plate-Wear
22	76-0840	1	Manifold
24	76-0940	1	End Cover ASM
25	92-9763	1	Rotor Set
☆25:1		1	Rotor
☆25:2		1	Vane
☆25:3		1	Stator
26	76-0880	1	Commutator ASM
☆26:1		1	Seal-Commutator
☆26:2		1	Commutator
☆26:3		1	Ring-Commutator
27	94-8178	1	Seal Kit
☆27:1		1	Seal-Dirt And Water
☆27:2		1	Washer-Backup
☆27:3		5	Seal-Ring
☆27:4		1	Washer-Backup
☆27:5		1	Seal-Inner
☆27:6		1	Seal-Commutator
28	76-0810	1	Housing ASM
☆28:1		1	Bearing
☆28:2		1	Housing

Ref. No.	Part No.	Qty.	Description
☆28:3		2	Washer-Thrust
☆28:4		1	Bearing-Thrust
☆28:5		1	Bearing

☆ Not serviced separately

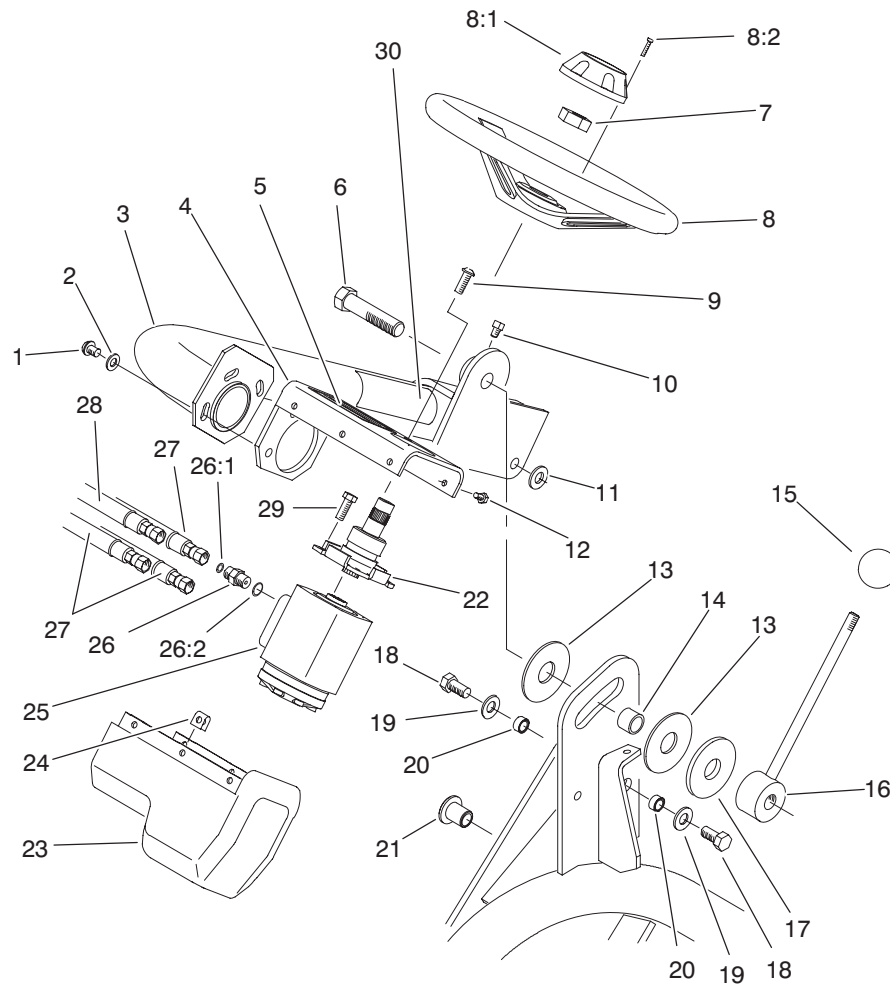

Sheet No.: 5

Steering Arm Assembly

Ref. No.	Part No.	Qty.	Description
1	3274-80	3	Screw-HH
2	3256-80	3	Washer-Flat
3	83-0650-01	1	Arm-Steering
4	83-0780-03	1	Support-Valve, Steering
5	93-8063	1	Decal-Warning (Europe)
5	104-2053	1	Decal-Warning
6	83-0750	1	Capscrew-HH, LH Thread
7	47-6990	1	Nut
8	68-5130	1	Wheel-Steering
8:1	68-5140	1	Cap-Steering Wheel
8:2	32144-21	1	Screw
9	3274-63	2	Screw-HSBH
10	3242-2	1	Screw-SQH
11	65-6390	1	Washer-Thrust, Plain
12	3274-39	6	Screw-HSBH
13	83-0740	2	Disc-Friction
14	83-0730	1	Spacer-Lockup
15	233-48	1	Knob
16	83-0700-03	1	Handle-Lockup
17	83-0760	1	Spacer-Plate, Lockup
18	325-4	2	Screw-HH
19	3256-26	2	Washer-Flat
20	47-2890	2	Bushing

Ref. No.	Part No.	Qty.	Description
21	83-1700	1	Bushing-Flange
22	83-1420	1	Column-Steering
23	83-0810	1	Cover-Steering
24	3290-277	6	Nut-Speed
25	92-8690	1	Steering Control Valve ASM
26	340-1	4	Adapter
26:1	237-35	1	O-Ring
26:2	237-42	1	O-Ring
27	83-1350	3	Hose-HYD
28	83-1360	1	Hose-HYD
29	323-4	2	Screw-HH
30	93-8068	1	Decal-Arm, Steering

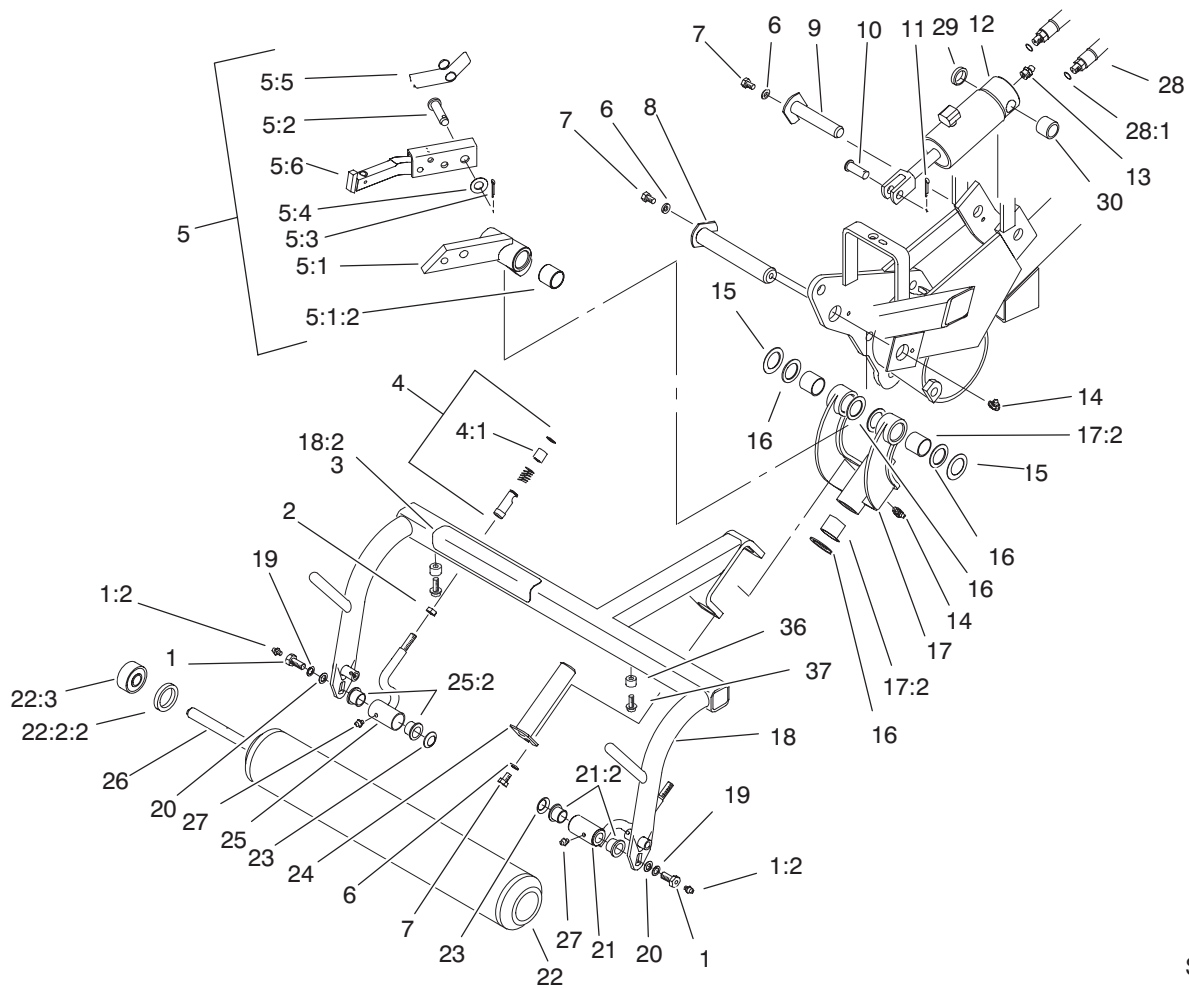

Sheet No.: 6

Right Hand Pull Frame Assembly

Ref. No.	Part No.	Qty.	Description
1	11-0160	2	Roller Shaft Screw ASM
1:2	302-5	1	Fitting-Grease
2	3220-3	2	Nut-Jam
3	93-8064	1	Decal-Danger (Europe)
4	99-1460	2	Ball Joint Receiver ASM
4:1	99-1461	1	Sleeve-Joint, Ball
☆5		1	RH Lift Arm ASM
5:1	62-2440	1	Lift Arm ASM
5:1:2	3-0348	2	Bushing
5:2	63-8750	1	Pin-Pivot
5:3	3272-11	1	Pin-Cotter
5:4	3256-26	1	Washer-Flat
5:5	57-7650	1	Spring-Torsion
5:6	94-5588-01	1	Bar-Lift
6	3256-23	3	Washer-Flat
7	322-1	3	Screw-HH
8	10-6110	1	Pin-Hinge
9	10-6060	1	Pin-Pivot, Ram
10	283-8	1	Pin-Clevis
11	3272-11	1	Pin-Cotter
12	105-3822	1	HYD Cylinder ASM
13	302-2	1	Fitting-Grease
14	302-60	2	Fitting-Grease

Ref. No.	Part No.	Qty.	Description
15	5-1226	2	Washer
16	10-8110	6	Washer-Thrust
17	10-7820	1	Pivot Hinge ASM
17:2	3-0348	4	Bushing
18	104-2055	1	Right Pull Frame ASM
18:2	62-5070	1	Decal-Warning
19	3253-21	2	Washer-Lock
20	3256-24	2	Washer-Flat
21	92-0586	1	Pull Arm ASM
21:2	3-1506	2	Bushing
22	99-4277	1	Roller ASM
☆*22:2		2	Hub Yoke ASM
22:2:2	253-83	1	Seal-Oil
22:3	251-141	2	Bearing-Ball
23	3290-317	2	Washer-Spring
24	10-6090	1	Pin-Pivot
25	92-0585	1	Pull Arm ASM
25:2	3-1506	2	Bushing
26	21-8470	1	Shaft-Roller
27	302-5	2	Fitting-Grease
28	92-9767	2	Hose
28:1	237-78	1	O-Ring
29	105-3828	1	Spacer
30	74-3730	1	Spacer-Spindle, Rear
36	94-4548	2	Bumper-Recessed
37	32144-44	2	Screw-HWH

☆ Not serviced separately

* Not illustrated

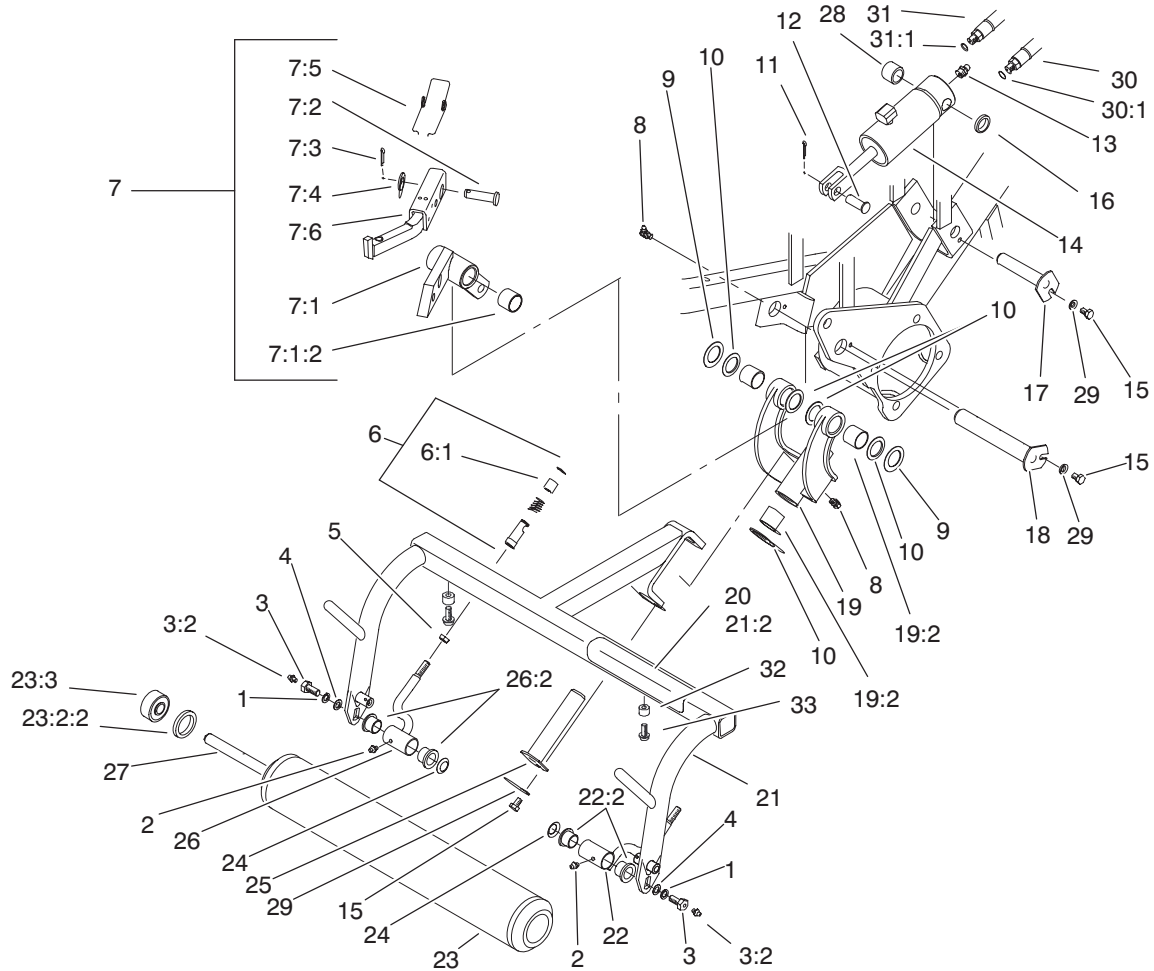

Sheet No.: 7

Left Hand Pull Frame Assembly

Ref. No.	Part No.	Qty.	Description
1	3253-21	2	Washer-Lock
2	302-5	2	Fitting-Grease
3	11-0160	2	Roller Shaft Screw
3:2	302-5	1	Fitting-Grease
4	3256-24	2	Washer-Flat
5	3220-3	2	Nut-Jam
6	99-1460	2	Ball Joint Receiver
6:1	99-1461	1	Sleeve-Joint, Ball
☆7		1	LH Lift Arm ASM
7:1	62-2460	1	Lift Arm ASM
7:1:2	3-0348	2	Bushing
7:2	63-8750	1	Pin-Pivot
7:3	3272-11	1	Pin-Cotter
7:4	3256-26	1	Washer-Flat
7:5	57-7650	1	Spring-Torsion
7:6	94-5586-01	1	Bar-Lift
8	302-60	2	Fitting-Grease
9	5-1226	2	Washer
10	10-8110	6	Washer-Thrust
11	3272-11	1	Pin-Cotter
12	283-8	1	Pin-Clevis
13	302-2	1	Fitting-Grease
14	105-3822	1	HYD Cylinder ASM
15	322-1	3	Screw-HH

Ref. No.	Part No.	Qty.	Description
16	105-3828	1	Spacer
17	10-6060	1	Pin-Pivot, Ram
18	10-6110	1	Pin-Hinge
19	10-7820	1	Pivot Hinge ASM
19:2	3-0348	4	Bushing
20	93-8064	1	Decal-Danger
21	104-2054	1	Left Pull Frame ASM
21:2	62-5070	1	Decal-Warning
22	92-0586	1	Pull Arm ASM
22:2	3-1506	2	Bushing
23	99-4277	1	Roller ASM
☆*23:2		2	Hub Yoke ASM
23:2:2	253-83	1	Seal-Oil
23:3	251-141	2	Bearing-Ball
24	3290-317	2	Washer-Spring
25	10-6090	1	Pin-Pivot
26	92-0585	1	Pull Arm ASM
26:2	3-1506	2	Bushing
27	21-8470	1	Shaft-Roller
28	74-3730	1	Spacer-Spindle, Rear
29	3256-23	3	Washer-Flat
30	83-1690	1	Hose-HYD
30:1	237-78	1	O-Ring
31	63-3850	1	Hose ASM
31:1	237-78	1	O-Ring

☆ Not serviced separately

* Not illustrated

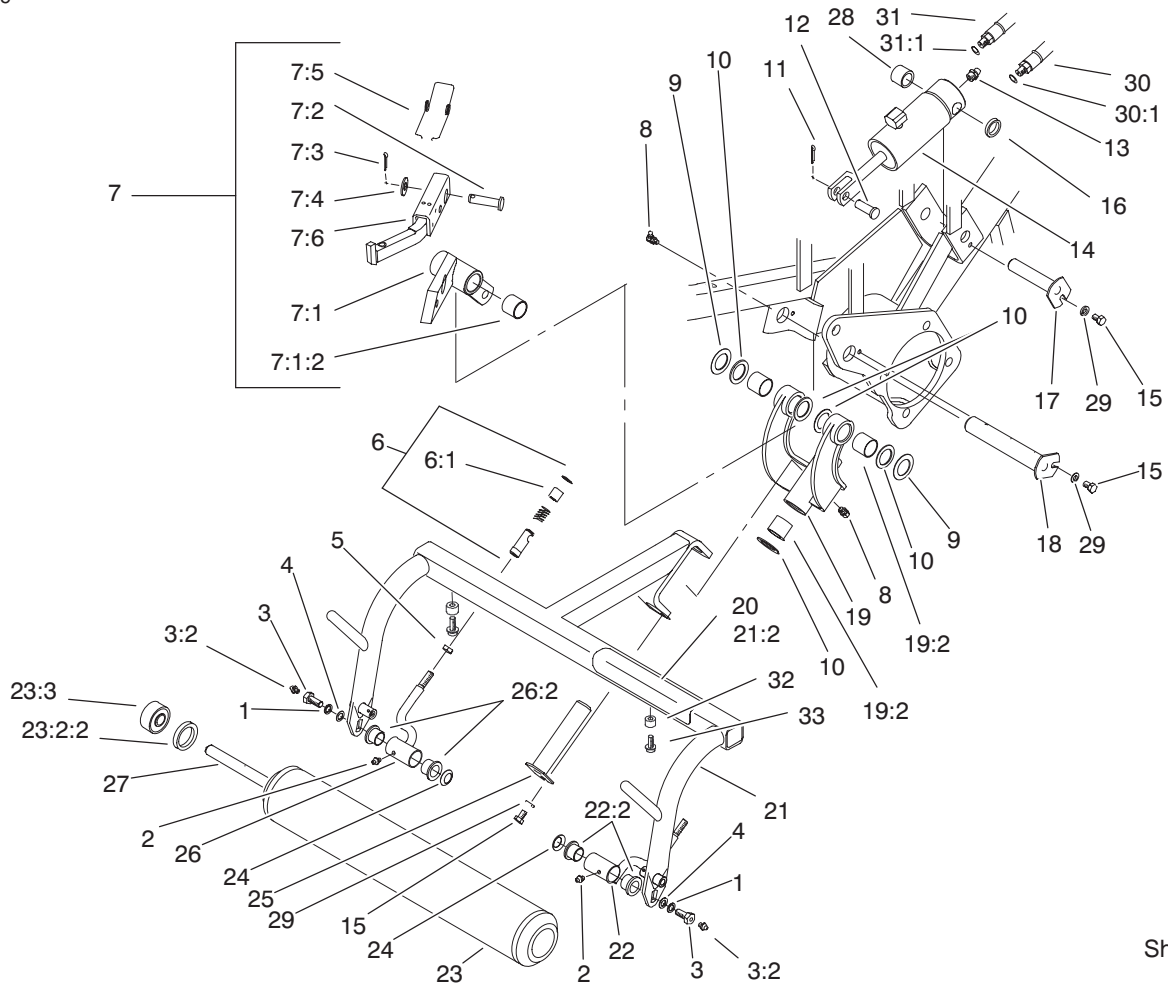

Sheet No.: 7

Left Hand Pull Frame Assembly (Continued)

Ref. No.	Part No.	Qty.	Description
32	94-4548	2	Bumper-Recessed
33	32144-44	2	Screw-HWH

Ref. No.	Part No.	Qty.	Description
----------	----------	------	-------------

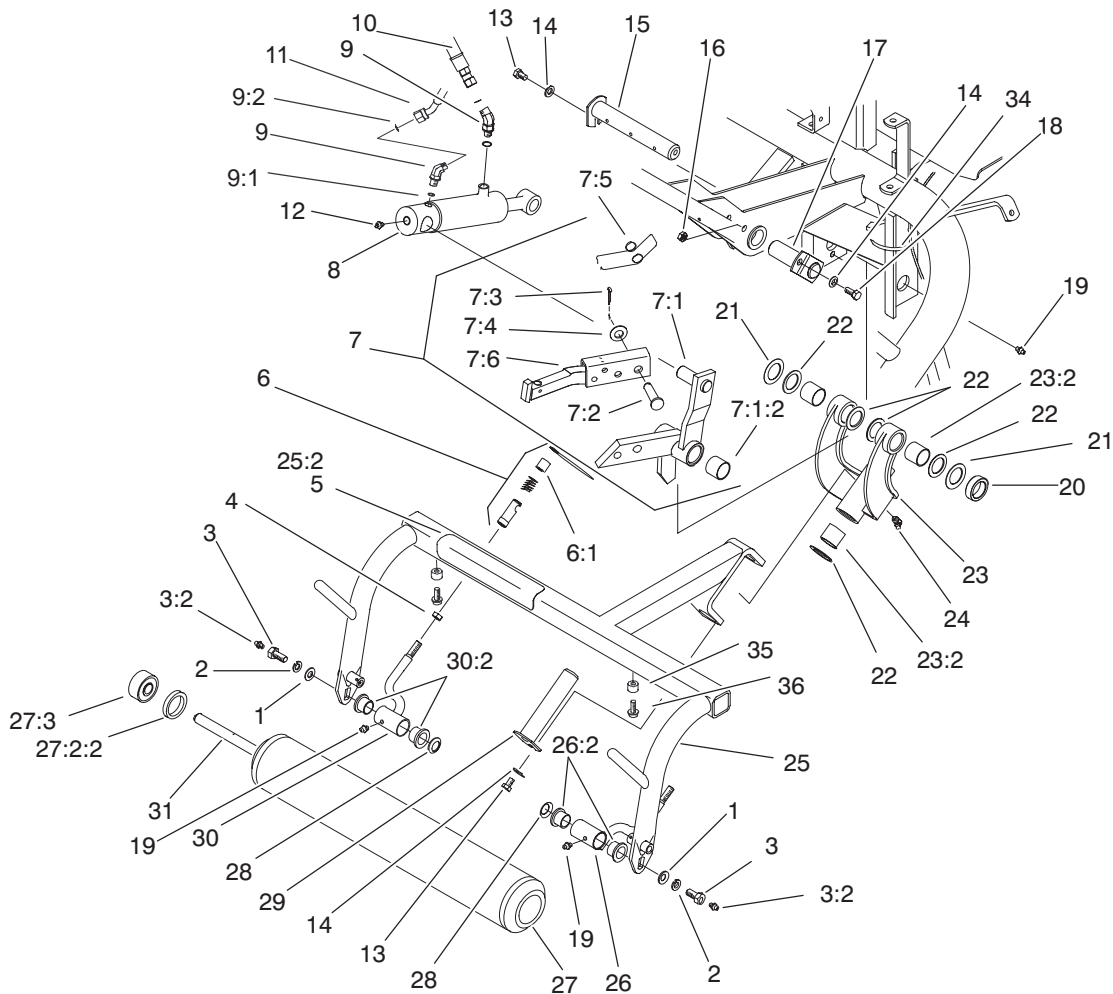

Sheet No.: 8

Rear Pull Frame Assembly

Ref. No.	Part No.	Qty.	Description	Ref. No.	Part No.	Qty.	Description
1	3256-24	2	Washer-Flat	12	302-2	1	Fitting-Grease
2	3253-21	2	Washer-Lock	13	322-1	2	Screw-HH
3	11-0160	2	Roller Shaft Screw	14	3256-23	3	Washer-Flat
3:2	302-5	1	Fitting-Grease	15	27-2550	1	Pin-Hinge
4	3220-3	2	Nut-Jam	16	3296-29	1	Nut-Lock, NI
5	93-8064	1	Decal-Danger (Europe)	17	68-5560	1	Pin-Cylinder, Pivot
6	99-1460	2	Ball Joint Receiver	18	322-3	1	Screw-HH
6:1	99-1461	1	Sleeve-Joint, Ball	19	302-5	3	Fitting-Grease
☆7		1	Center Lift Arm ASM	20	93-2384	1	Spacer-Carrier
7:1	68-5380	1	Center Lift Arm ASM	21	5-1226	2	Washer
7:1:2	3-0348	2	Bushing	22	10-8110	6	Washer-Thrust
7:2	63-8750	1	Pin-Pivot	23	105-0452	1	Pivot Hinge ASM
7:3	3272-11	1	Pin-Cotter	23:2	3-0348	4	Bushing
7:4	3256-26	1	Washer-Flat	24	302-60	1	Fitting-Grease
7:5	57-7650	1	Spring-Torsion	25	105-0451	1	Rear Pull Frame ASM
7:6	62-2420-01	1	Bar-Lift	25:2	62-5070	1	Decal-Warning
8	105-3823	1	Hydraulic Cylinder	26	92-0586	1	Pull Arm ASM
9	340-103	2	Fitting-HYD, 45°	26:2	3-1506	2	Bushing
9:1	237-78	1	O-Ring	27	99-4277	1	Roller ASM
9:2	237-21	1	O-Ring	☆*27:2		2	Hub Yoke ASM
10	83-1680	1	Hose-HYD	27:2:2	253-83	1	Seal-Oil
11	88-9700	1	Hose-HYD	27:3	251-141	2	Bearing-Ball
				28	3290-317	2	Washer-Spring
				29	10-6090	1	Pin-Pivot
				30	92-0585	1	Pull Arm ASM
				30:2	3-1506	2	Bushing

☆ Not serviced separately

* Not illustrated

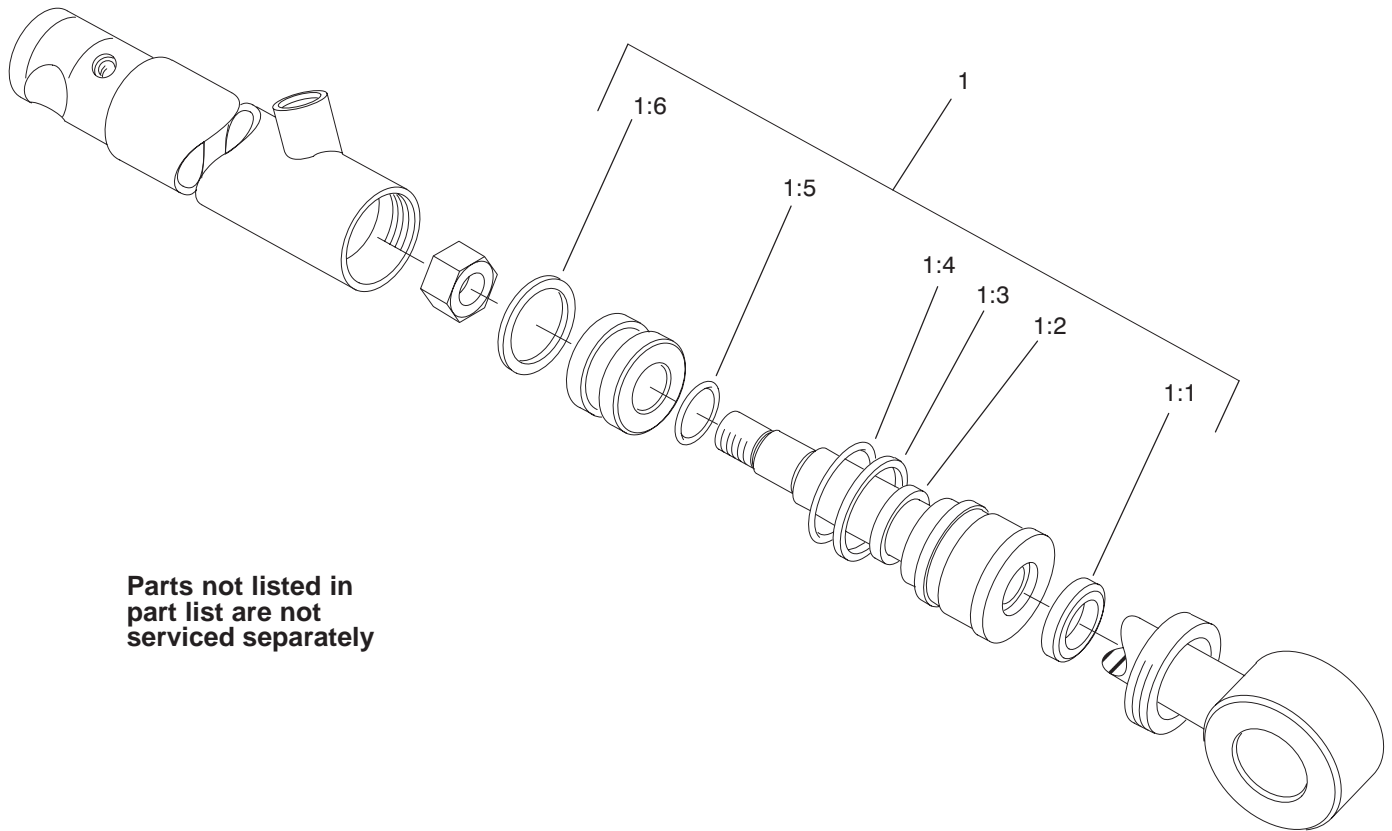

**Parts not listed in
part list are not
serviced separately**

Sheet No.: A4
T-3848

Hydraulic Cylinder Assembly No. 105-3823

Ref. No.	Part No.	Qty.	Description
1	105-3835	1	Seal Kit
☆1:1		1	Seal-Dust
☆1:2		1	Seal-Rod
☆1:3		1	Backup
☆1:4		1	O-Ring
☆1:5		1	O-Ring
☆1:6		1	T-Seal

Ref. No.	Part No.	Qty.	Description

☆ Not serviced separately

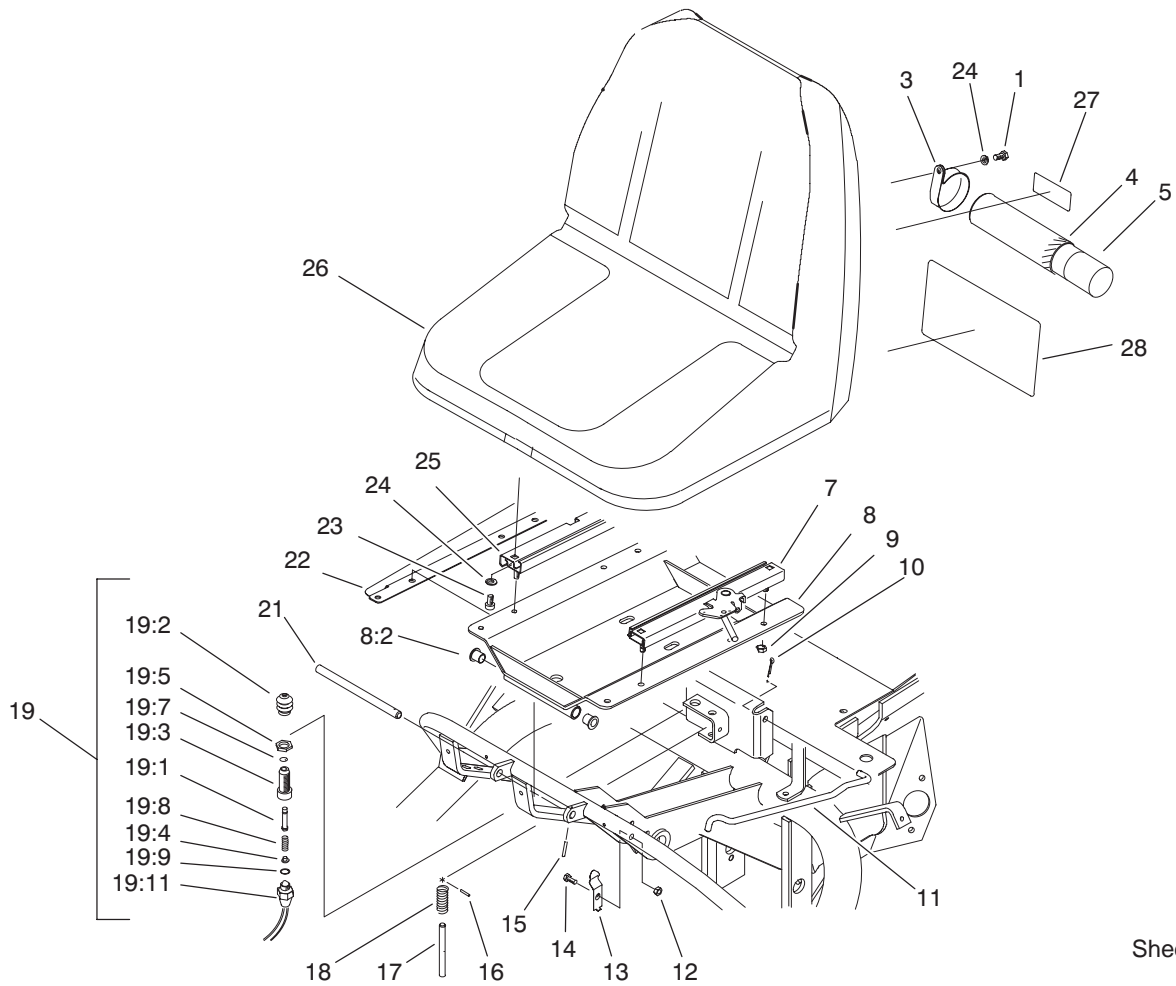

Sheet No.: 9

Seat Assembly

Ref. No.	Part No.	Qty.	Description
1	322-2	2	Screw-HH
3	2412-133	2	R-Clamp
4	104-7050	1	Housing-Manual
5	104-7048	1	Cap-Housing
7	51-0790	1	Adjuster-Seat, LH
8	83-1270	1	Seat Support ASM
8:2	256-155	2	Bushing-Flange
9	3296-29	4	Nut-Lock, NI
10	3272-11	1	Pin-Cotter
11	68-5100	1	Rod-Seat, Prop
12	3296-16	1	Nut-Lock, NI
13	68-5310	1	Clip-Rod, Prop
14	321-3	1	Screw-HH
15	32121-45	1	Pin-Spring
16	3284-3	1	Pin-Groove
17	51-0350	1	Pin-Spring, Seat
18	3-6685	1	Spring
19	43-9071	1	Limit Switch ASM
19:1	43-8860	1	Plunger-Switch
19:2	43-8870	1	Boot-Switch
19:3	43-8620	1	Pin-Guide, Switch
19:4	43-8610	1	Guide
19:5	218-461	2	Nut-HH
19:7	237-7	1	O-Ring
19:8	43-8600	1	Spring-Compression
19:9	237-30	1	O-Ring

Ref. No.	Part No.	Qty.	Description
19:11	72-4320	1	Switch-Ball, N.o.
21	49-5880	1	Shaft-Support, Seat
22	83-1840-01	1	Cover-Valve, RH
23	3274-12	4	Screw-HSH
24	3256-23	6	Washer-Flat
25	51-0780	1	Slider-Seat
26	100-3187	1	Seat ASM
27	93-6686	1	Decal-Oil, HYD
28	106-6374	1	Decal-Service, Portuguese
28	106-6375	1	Decal-Service, Norwegian
28	106-6370	1	Decal-Service, French
28	106-6367	1	Decal-Service
28	106-6368	1	Decal-Service, Japanese
28	106-6369	1	Decal-Service, Spanish
28	106-6371	1	Decal-Service, German
28	106-6372	1	Decal-Service, Swedish
28	106-6373	1	Decal-Service, Italian
28	106-6376	1	Decal-Service, Finnish
28	106-6377	1	Decal-Service, Danish

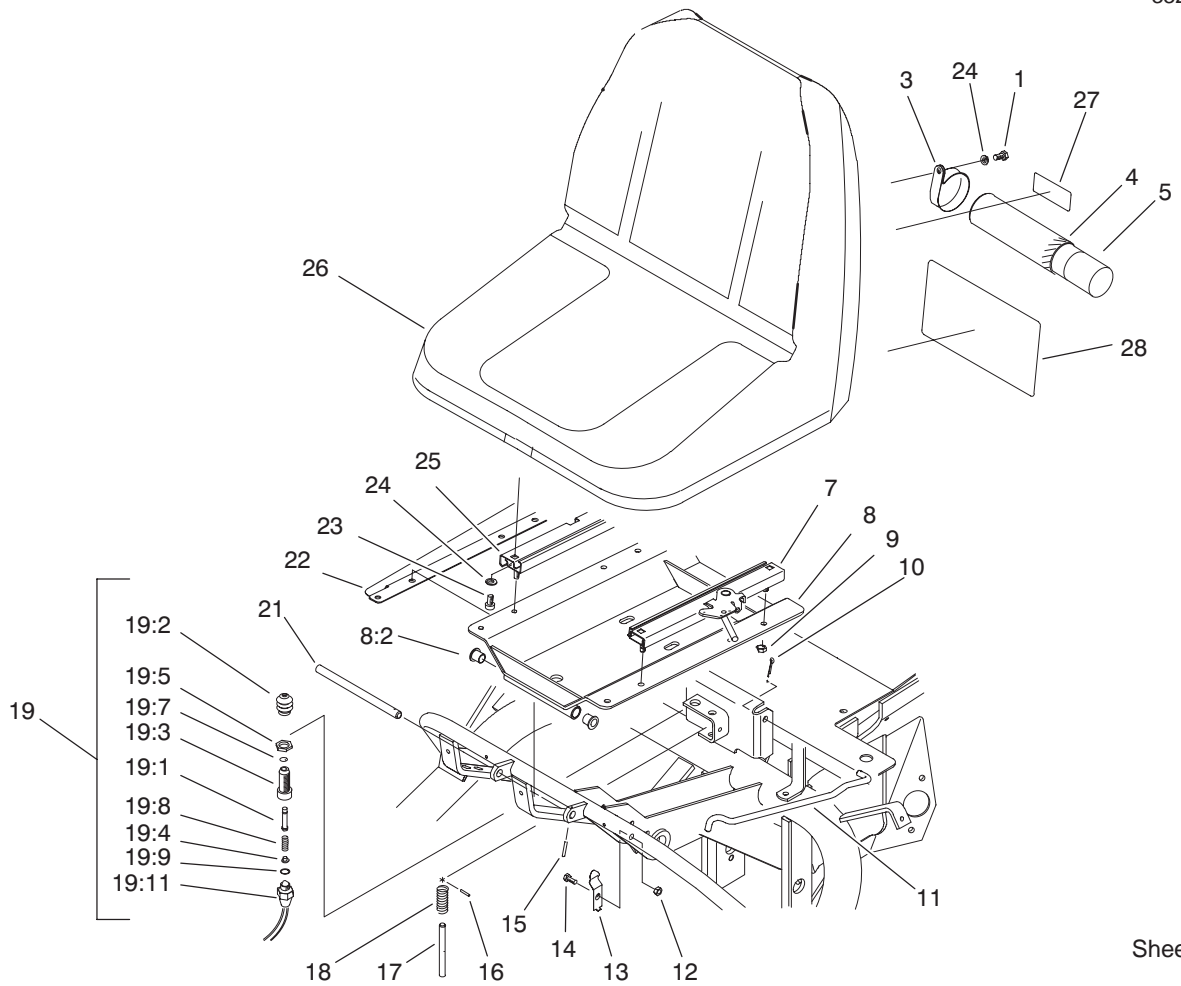

Sheet No.: 9

Seat Assembly (Continued)

Ref. No.	Part No.	Qty.	Description
28	106-6378	1	Decal-Service, Dutch

Ref. No.	Part No.	Qty.	Description

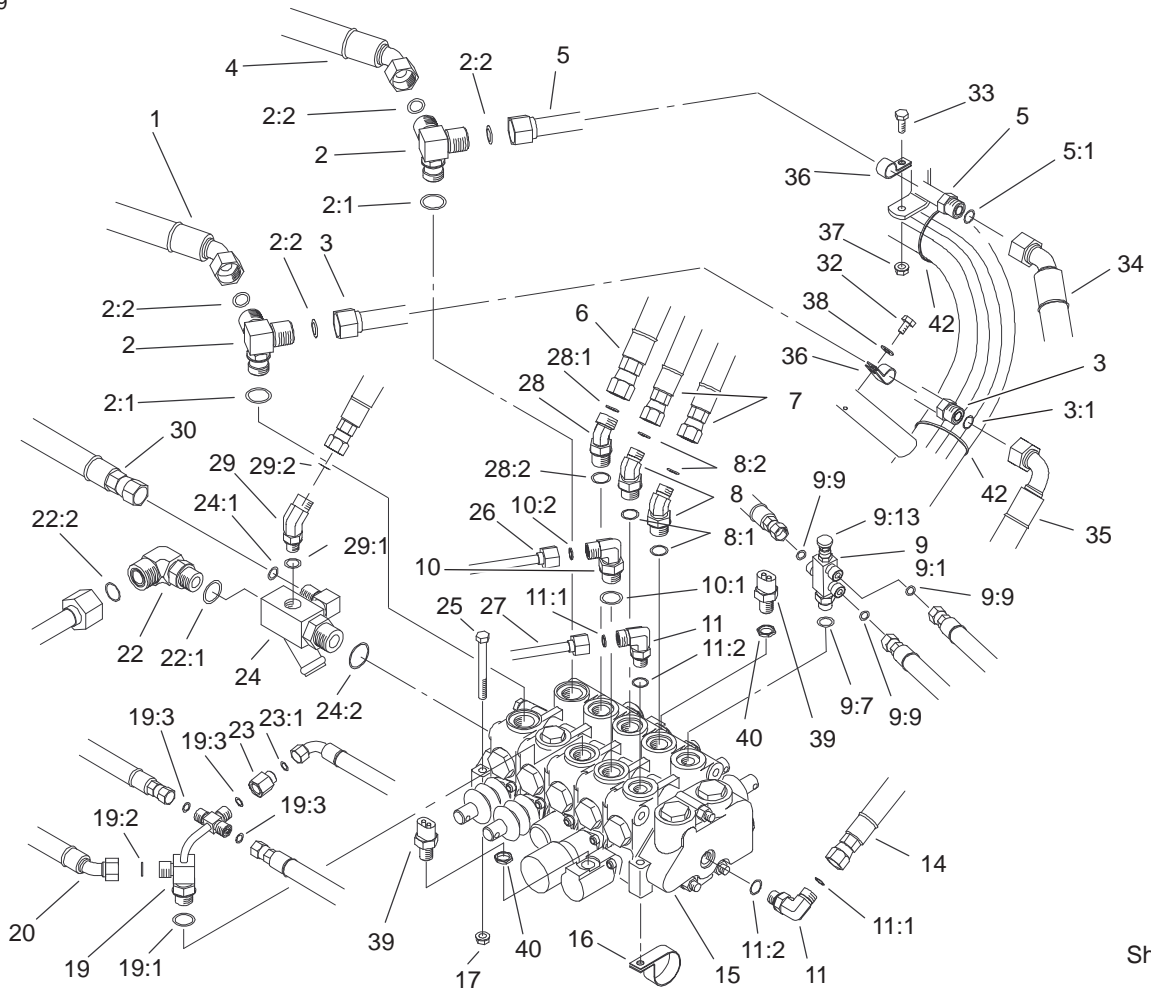

Sheet No.: 10

Control Valve Installation Assembly

Ref. No.	Part No.	Qty.	Description
1	98-0647	1	Hose-HYD
2	63-4050	2	Fitting
2:1	237-80	1	O-Ring
2:2	237-65	2	O-Ring
3	70-7130	1	Line-Tube
3:1	237-65	2	O-Ring
4	98-0646	1	Hose-Hydraulic
5	83-1200	1	Tube-Traction, LH Lower
5:1	237-65	1	O-Ring
6	98-2151	1	Hose-HYD
7	98-0649	2	Hose-HYD
8	340-138	2	Fitting-HYD, 45°
8:1	237-79	1	O-Ring
8:2	237-22	1	O-Ring
9	93-2556	1	Needle Valve ASM
9:1	93-2555	1	Fitting-Body
9:7	237-42	1	O-Ring
9:9	237-21	3	O-Ring
9:13	93-2554	1	Needle ASM
10	340-18	1	Fitting-HYD, 90°
10:1	237-79	1	O-Ring
10:2	237-22	1	O-Ring
11	340-77	2	Fitting-HYD, 90°
11:1	237-22	1	O-Ring
11:2	237-42	1	O-Ring

Ref. No.	Part No.	Qty.	Description
14	98-2150	1	Hose-HYD
15	105-3800	1	Control Valve ASM
16	304-61	1	Clamp-Hose
17	32128-20	3	Nut-HF
19	83-1670	1	Fitting ASM
19:1	237-79	1	O-Ring
19:2	237-22	1	O-Ring
19:3	237-21	3	O-Ring
20	95-5986	1	Hose-HYD
22	340-16	1	Fitting-Elbow-90
22:1	237-80	1	O-Ring
22:2	237-58	1	O-Ring
23	71-0990	1	Orifice
23:1	237-21	1	O-Ring
24	68-5260	1	Manifold-Tee
24:1	237-30	1	O-Ring
24:2	237-81	1	O-Ring
25	322-14	3	Screw-HH
26	63-4030	1	Tube-HYD
27	63-4020	1	Tube-HYD
28	340-101	1	Fitting-HYD, 90°
28:1	237-30	1	O-Ring
28:2	237-79	1	O-Ring
29	340-137	1	Fitting
29:1	237-21	1	O-Ring
29:2	237-42	1	O-Ring

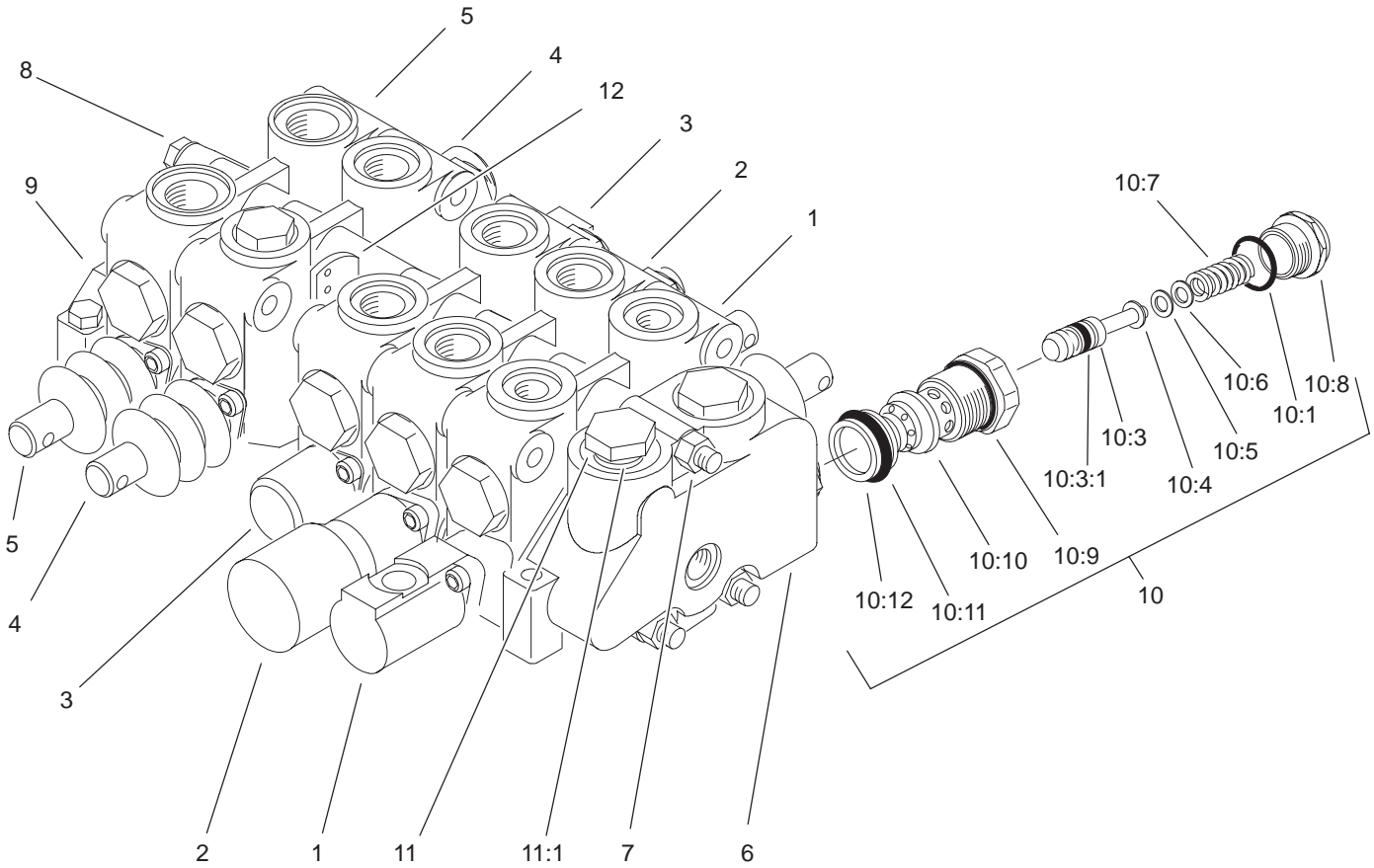

T-3794
Sheet No.:A5

Control Valve Assembly No. 105-3800

Ref. No.	Part No.	Qty.	Description
1	105-3801	1	Section 1 ASM
2	105-3802	1	Section 2 ASM
3	105-3803	1	Section 3 ASM
4	105-3804	1	Section 4 ASM
5	93-1386	1	Section 5 ASM
6	353-772	1	Cover-Left
7	3217-7	3	Nut-Hex
8	353-853	3	Bolt
9	353-668	1	Plate-Cover
10	353-766	1	Cart-Relief
10:1	237-54	1	O-Ring
10:3	353-531	1	Poppet And Ring ASM
10:3:1	353-392	1	Ring-Piston
10:4	353-328	1	Shim (.040)
10:5	353-329	1	Shim (.020)
10:6	353-330	1	Shim (.010)
10:7	353-855	1	Spring
10:8	353-334	1	Cap-Relief
10:9	353-331	1	O-Ring
10:10	353-760	1	Relief-Body
10:11	353-758	1	O-Ring
10:12	353-952	1	Seal-Back-Up
11	353-721	2	Plug
11:1	237-54	1	O-Ring
12	354-122	1	Disc-Seal
*13	92-2545	1	Spool Set Kit

Ref. No.	Part No.	Qty.	Description
*14	84-2190	1	Section Seal Kit
☆*14:1		12	O-Ring
☆*14:2		12	O-Ring
☆*14:3		16	O-Ring
☆*14:4		8	O-Ring
☆*14:5		1	Disc-Seal
☆*14:6		1	Disc-Seal

* Not illustrated
☆ Not serviced separately

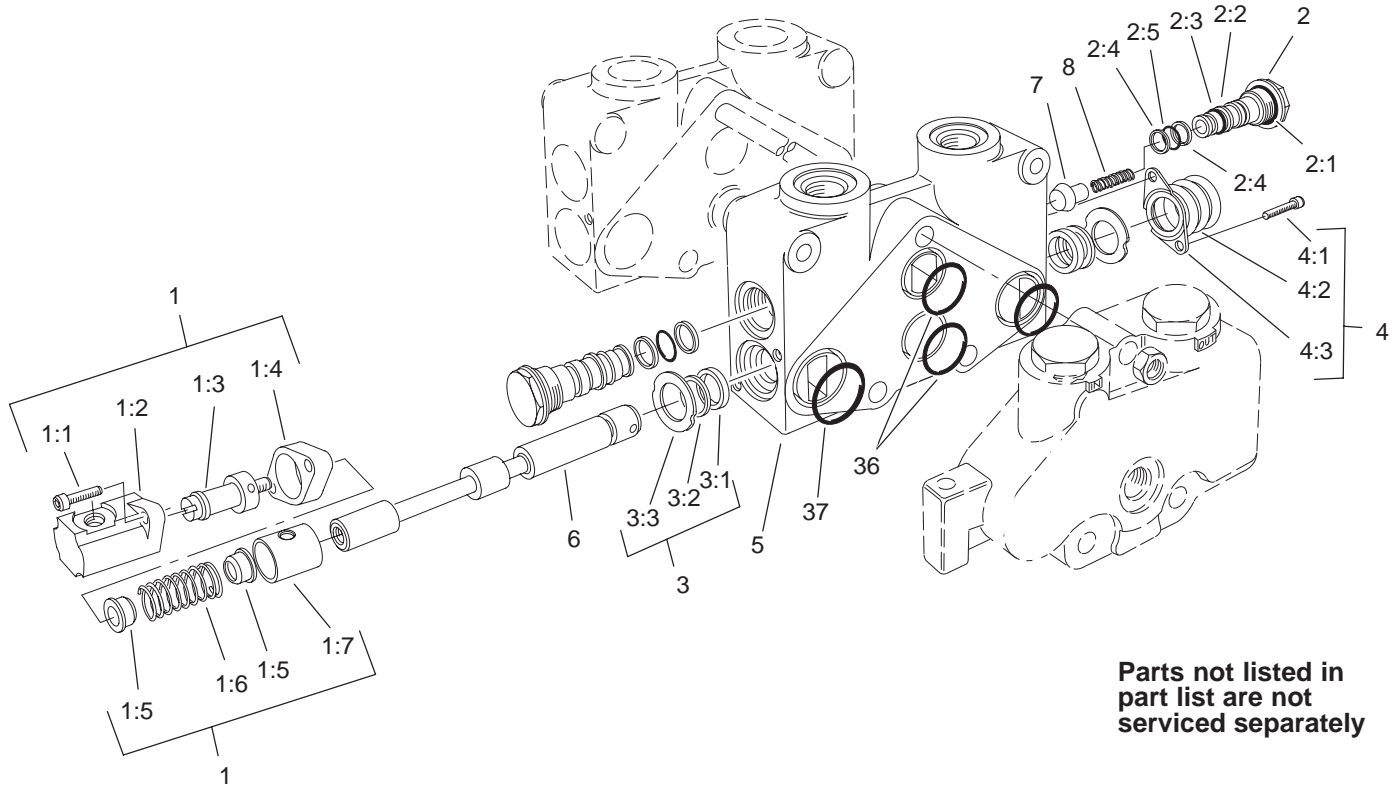

T-3777
Sheet No.:A6

Section 1 Assembly No. 105-3801

Ref. No.	Part No.	Qty.	Description
1	105-3807	1	Positioner-Interlock
1:1	3274-70	2	Screw-HSH
1:2	353-727	1	Bonnet-Special
1:3	104-7739	1	Spud-V20
1:4	353-733	1	Spacer-Bonnet
1:5	353-417	2	Collar-Stop
1:6	104-7741	1	Spring
1:7	353-728	1	Sleeve
2	353-481	2	Lift Check ASM
2:1	237-54	1	O-Ring
2:2	353-306	1	Washer-Backup
2:3	353-305	1	O-Ring
2:4	353-303	2	Washer-Backup
2:5	353-302	1	O-Ring
3	92-2548	2	Spool Set Kit
3:1	353-957	1	Cup-Seal
3:2	92-2546	1	Wiper-Seal
3:3	92-2547	1	Seal-Retainer
4	93-3652	1	Boot-Dust
4:1	3274-52	2	Screw-HSH
4:2	353-575	1	Boot
4:3	93-3651	1	Retainer-Boot
☆5		1	Housing-V20c
☆6		1	Spool-V20c
7	353-301	1	Check-Lift, Poppet
8	353-304	1	Spring-Check, Lift

Ref. No.	Part No.	Qty.	Description
☆36		2	O-Ring
☆37		2	O-Ring

☆ Not serviced separately

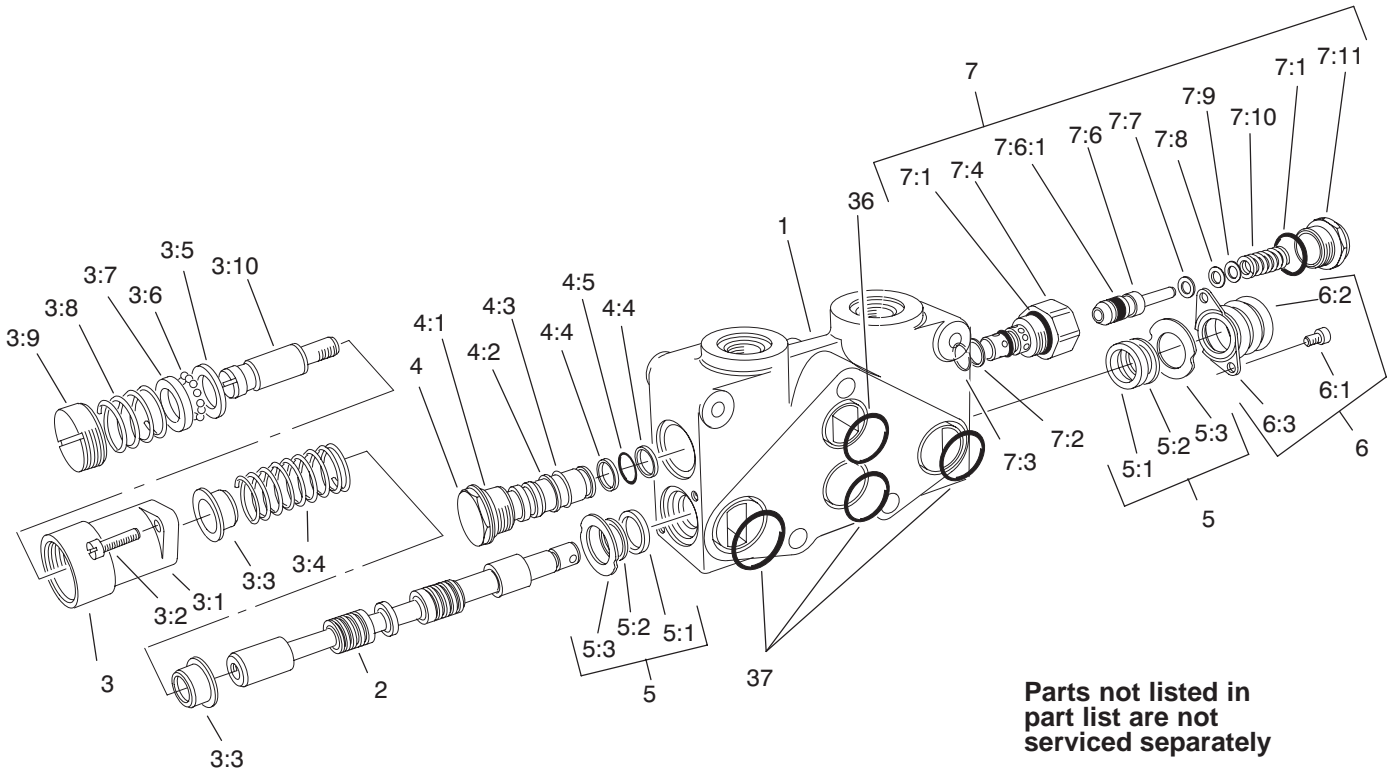

T-3778
Sheet No.:A7

Section 2 Assembly No. 105-3802

Ref. No.	Part No.	Qty.	Description
☆1		1	Housing-V20t
☆2		1	Spool-V20
3	105-3806	1	Positioner
3:1	99-8181	1	Bonnet-R
3:2	3274-15	2	Screw-HSH
3:3	353-417	2	Collar-Stop
3:4	104-7741	1	Spring
3:5	354-29	1	Plate-Thrust
3:6	52-5880	12	Ball-Detent
3:7	42-2680	1	Race-Ball
3:8	104-7727	1	Spring-Detent
3:9	353-763	1	Cap-Adjustment
3:10	353-762	1	Spud-Out
4	353-481	1	Lift Check ASM
4:1	237-54	1	O-Ring
4:2	353-306	1	Washer-Backup
4:3	353-305	1	O-Ring
4:4	353-303	2	Washer-Backup
4:5	353-302	1	O-Ring
5	92-2548	2	Spool Set Kit
5:1	353-957	1	Cup-Seal
5:2	92-2546	1	Wiper-Seal
5:3	92-2547	1	Seal-Retainer
6	93-3652	1	Boot-Dust
6:1	3274-52	2	Screw-HSH
6:2	353-575	1	Boot

Ref. No.	Part No.	Qty.	Description
6:3	93-3651	1	Retainer-Boot
7	353-642	1	Cartridge-Relief
7:1	237-54	2	O-Ring
7:2	353-306	1	Washer-Backup
7:3	353-305	1	O-Ring
7:4	353-851	1	Body-Relief
7:6	353-531	1	Poppet And Ring ASM
7:6:1	353-392	1	Ring-Piston
7:7	353-328	1	Shim (.040)
7:8	353-329	1	Shim (.020)
7:9	353-330	1	Shim (.010)
7:10	353-398	1	Spring
7:11	353-334	1	Cap-Relief
☆36		1	O-Ring
☆37		3	O-Ring

☆ Not serviced separately

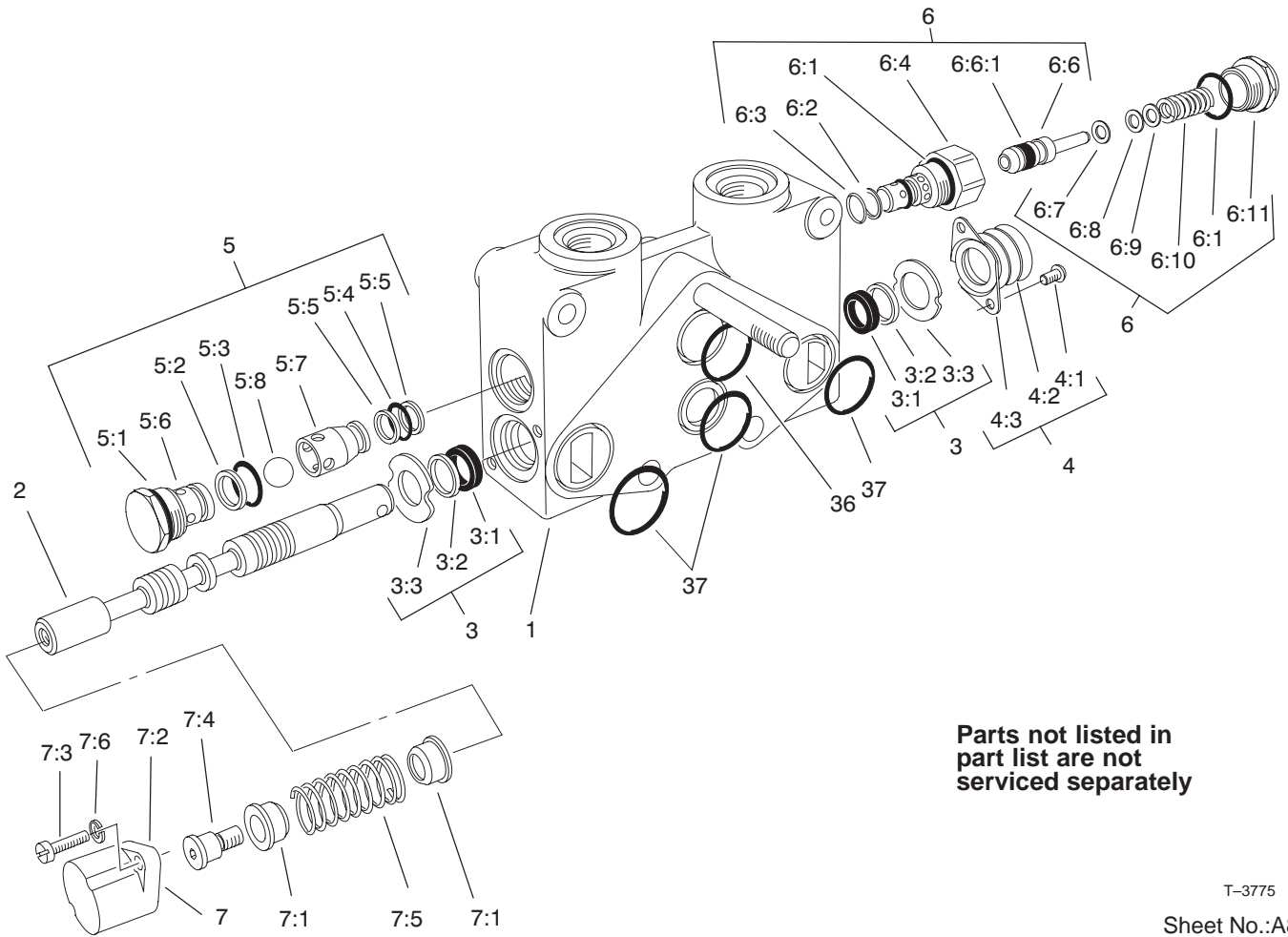

T-3775

Sheet No.:A8

Section 3 Assembly No. 105-3803

Ref. No.	Part No.	Qty.	Description
☆1		1	Housing-V20t
☆2		1	Spool-V20
3	92-2548	2	Spool Set Kit
3:1	353-957	1	Cup-Seal
3:2	92-2546	1	Wiper-Seal
3:3	92-2547	1	Seal-Retainer
4	93-3652	1	Boot-Dust
4:1	3274-52	2	Screw-HSH
4:2	353-575	1	Boot
4:3	93-3651	1	Retainer-Boot
5	354-129	1	Anticavitation Check ASM
5:1	237-54	1	O-Ring
5:2	353-306	1	Washer-Backup
5:3	353-305	1	O-Ring
5:4	353-302	1	O-Ring
5:5	353-303	2	Washer-Backup
5:6	353-483	1	Body-Check
5:7	353-484	1	Return-Ball, Check
5:8	353-737	1	Ball-Check
6	353-642	1	Cartridge-Relief
6:1	237-54	2	O-Ring
6:2	353-306	1	Washer-Backup
6:3	353-305	1	O-Ring
6:4	353-851	1	Body-Relief
6:6	353-531	1	Poppet And Ring ASM

Ref. No.	Part No.	Qty.	Description
6:6:1	353-392	1	Ring-Piston
6:7	353-328	1	Shim (.040)
6:8	353-329	1	Shim (.020)
6:9	353-330	1	Shim (.010)
6:10	353-398	1	Spring
6:11	353-334	1	Cap-Relief
7	105-3808	1	Positioner-Spring Return
7:1	353-417	2	Collar-Stop
7:2	99-6895	1	Bonnet
7:3	52-5900	2	Screw
7:4	52-5860	1	Collar-Spool
7:5	104-7741	1	Spring
7:6	3253-3	2	Washer-Lock
☆36		1	O-Ring
☆37		3	O-Ring

☆ Not serviced separately

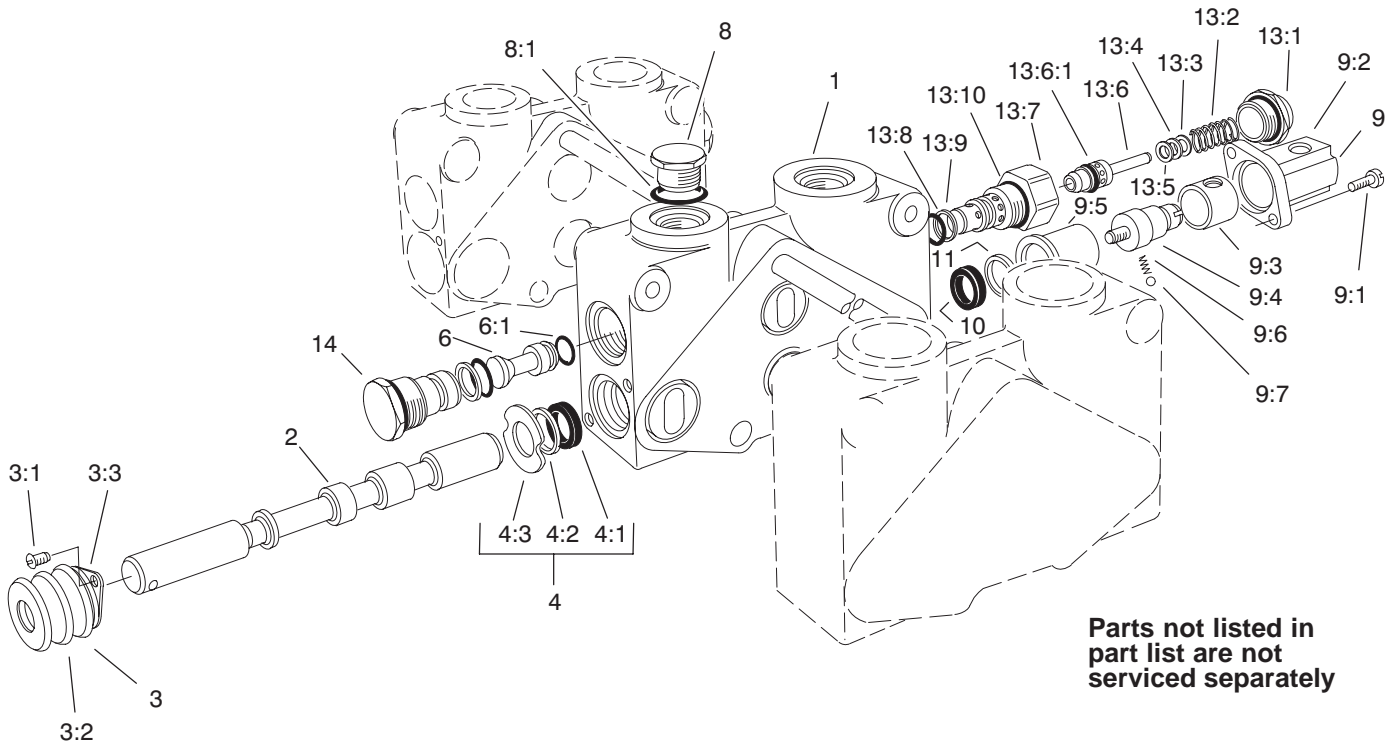

T-3776
Sheet No.:A9

Section 4 Assembly No. 105-3804

Ref. No.	Part No.	Qty.	Description
☆1		1	Housing-V20p
☆2		1	Spool-V20
3	93-3652	1	Boot-Dust
3:1	3274-52	2	Screw-HSH
3:2	353-575	1	Boot
3:3	93-3651	1	Retainer-Boot
4	92-2548	1	Spool Set Kit
4:1	353-957	1	Cup-Seal
4:2	92-2546	1	Wiper-Seal
4:3	92-2547	1	Seal-Retainer
6	353-844	1	Plug
6:1	353-850	1	O-Ring
8	353-550	1	Plug-HYD
8:1	237-79	1	O-Ring
9	353-840	1	Bonnet ASM
9:1	52-5900	2	Screw
9:2	353-847	1	Bonnet
9:3	353-849	1	Sleeve
9:4	353-846	1	Spud
9:5	353-845	1	Sleeve-Detent
9:6	353-730	1	Spring
9:7	353-731	1	Ball
10	353-957	1	Cup-Seal
11	353-958	1	Washer
13	354-140	1	Relief-Rcm
13:1	353-334	1	Cap-Relief

Ref. No.	Part No.	Qty.	Description
13:2	353-398	1	Spring
13:3	353-330	1	Shim (.010)
13:4	353-329	1	Shim (.020)
13:5	353-328	1	Shim (.040)
13:6	353-531	1	Poppet And Ring ASM
13:6:1	353-392	1	Ring-Piston
13:7	353-851	1	Body-Relief
13:8	353-305	1	O-Ring
13:9	353-306	1	Washer-Backup
13:10	237-54	2	O-Ring
14	353-953	1	Plug ASM

☆ Not serviced separately

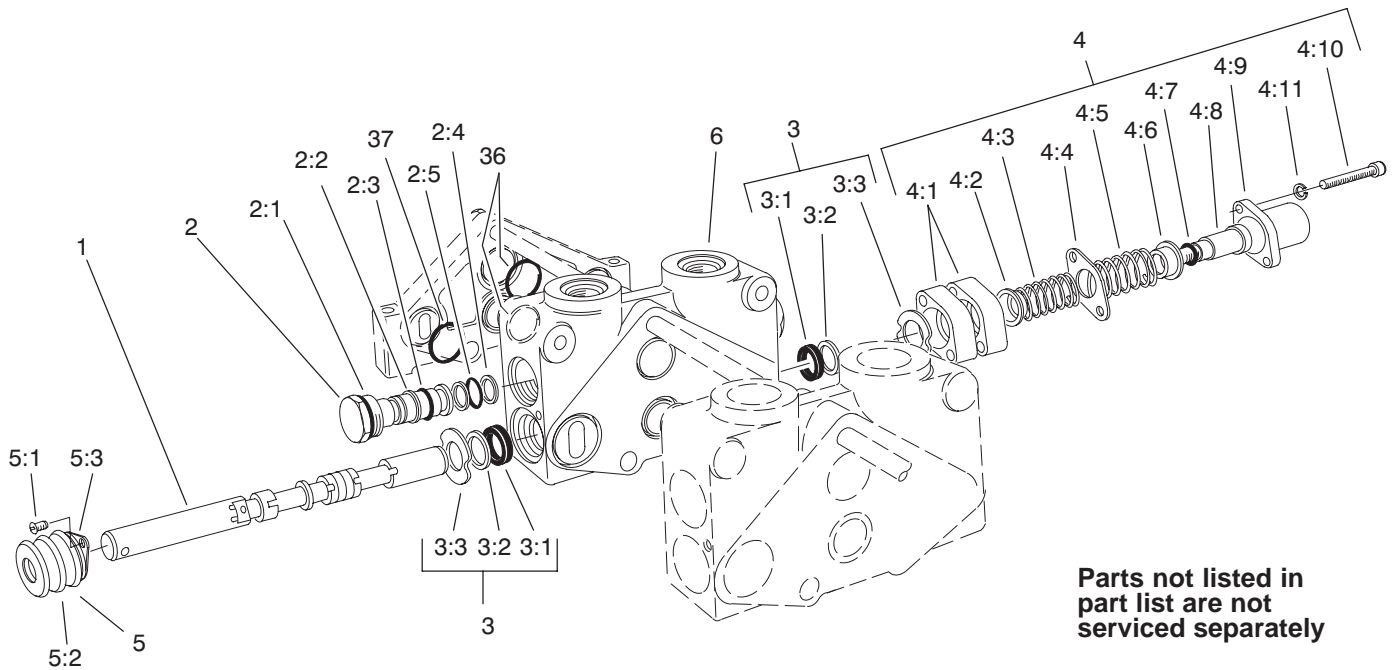

T-3779
Sheet No.:B1

Section 5 Assembly No. 93-1386

Ref. No.	Part No.	Qty.	Description
1	94-5434	1	Spool
2	353-481	2	Lift Check ASM
2:1	237-54	1	O-Ring
2:2	353-306	1	Washer-Backup
2:3	353-305	1	O-Ring
2:4	353-303	2	Washer-Backup
2:5	353-302	1	O-Ring
3	92-2548	2	Spool Set Kit
3:1	353-957	1	Cup-Seal
3:2	92-2546	1	Wiper-Seal
3:3	92-2547	1	Seal-Retainer
4	353-833	1	Positioner ASM
4:1	353-733	2	Spacer-Bonnet
4:2	353-417	1	Collar-Stop
4:3	353-831	1	Spring
4:4	353-529	1	Plate-Retainer, Seal
4:5	92-3148	1	Spring-Traction
4:6	353-808	1	Collar-Spring
4:7	353-830	1	O-Ring
4:8	94-4248	1	Collar-Spool
4:9	99-6895	1	Bonnet
4:10	354-28	2	Screw-HS
4:11	3253-4	2	Washer-Lock
5	93-3652	1	Boot-Dust
5:1	3274-52	2	Screw-HSH
5:2	353-575	1	Boot

Ref. No.	Part No.	Qty.	Description
5:3	93-3651	1	Retainer-Boot
☆6		1	Housing-V20p
☆36		1	O-Ring
☆37		3	O-Ring

☆ Not serviced separately

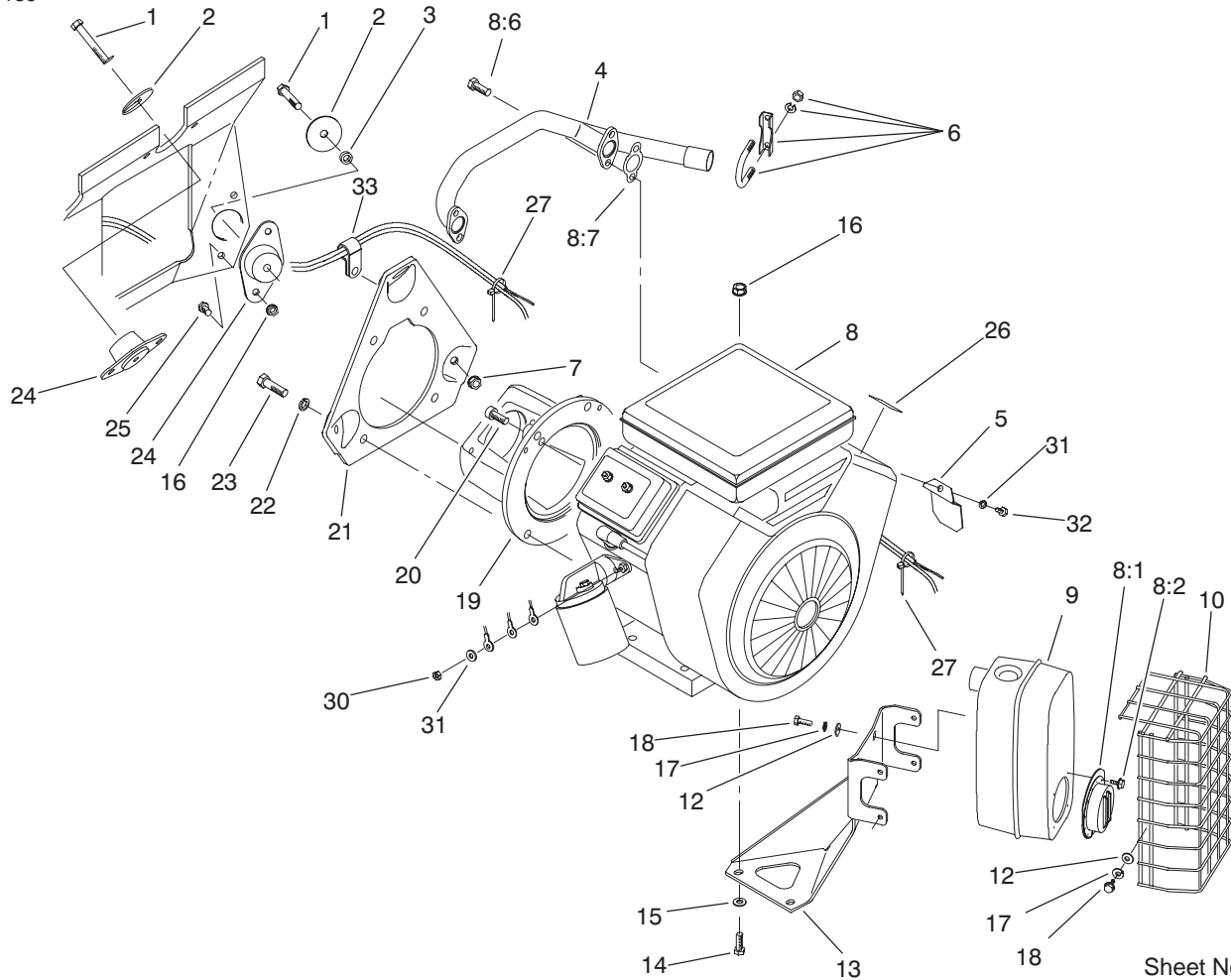

Sheet No.: 11

Engine Installation Assembly

Ref. No.	Part No.	Qty.	Description
1	323-12	3	Screw-HH
2	83-1040	3	Washer-Flat
3	83-1050	2	Spacer
4	83-1080	1	Exhaust Manifold ASM
5	83-2310	1	Shield-Regulator
6	2112-11	1	Clamp-Muffler
7	3290-357	3	Nut-HHF
8	106-4618	1	Engine-18hp, Vanguard
☆8:1		1	Deflector-Exhaust
☆8:2		4	Screw-HH
☆8:6		4	Capscrew-Flange, HH
☆8:7		2	Gasket-Manifold, Exhaust
9	98-0616	1	Muffler ASM
10	83-1400-03	1	Shield-Muffler
12	3256-1	8	Washer-Flat
13	83-1630-03	1	Bracket-Support, Muffler
14	322-8	2	Screw-HH
15	3256-23	2	Washer-Flat
16	32128-20	8	Nut-HF
17	3253-3	8	Washer-Lock
18	49-2040	8	Screw-Tapping
19	83-1060-03	1	Adapter-Pump
20	3274-7	2	Screw-HSH

Ref. No.	Part No.	Qty.	Description
21	85-8120-03	1	Plate-Mount, Engine
22	3253-6	4	Washer-Lock
23	324-7	4	Screw-HH
24	83-1030	3	Mount-Engine
25	322-3	6	Screw-HH
26	93-8069	1	Decal-Surface, Hot
27	3290-379	2	Tie-Cable
30	43-2830	1	Nut-Hex
31	43-5930	2	Washer-Spring
32	33113-016	1	Screw-HH
33	2412-81	1	Clamp

☆ Not serviced separately

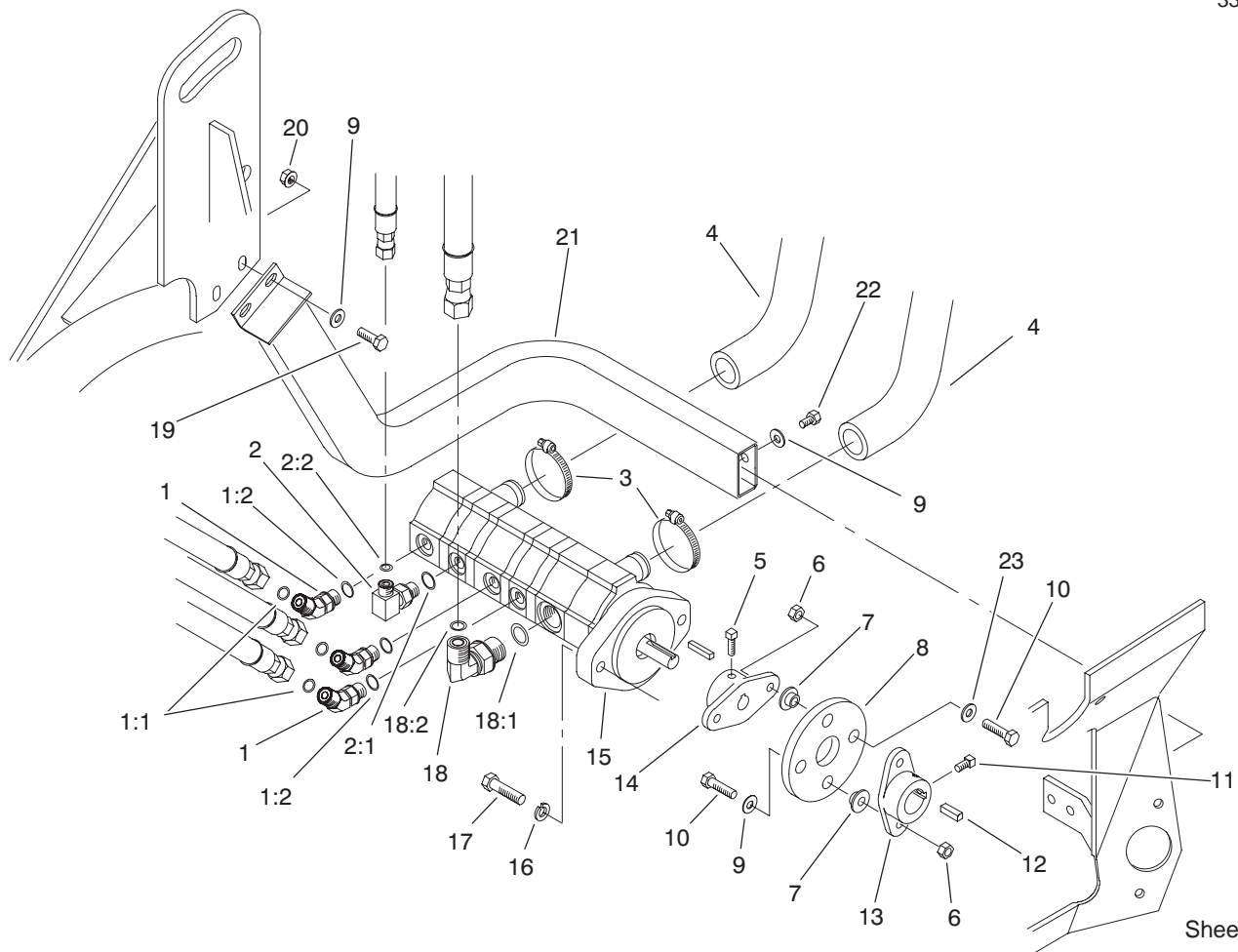

Sheet No.: 12

Hydraulic Pump Installation Assembly

Ref. No.	Part No.	Qty.	Description
1	340-87	3	Fitting-HYD, 45°
1:1	237-22	1	O-Ring
1:2	237-42	1	O-Ring
2	340-82	1	Adapter
2:1	237-42	1	O-Ring
2:2	237-21	1	O-Ring
3	2412-34	2	Clamp-Hose
4	95-5966	2	Hose-Pump Inlet
5	3241-6	2	Screw-SQH
6	3296-29	4	Nut-Lock, NI
7	27-6600	4	Spacer-Coupling
8	44-2230	1	Coupling-Rubber
9	3256-23	4	Washer-Flat
10	322-6	4	Screw-HH
11	3241-2	2	Screw-SQH
12	10-7070	1	Key-Square
13	27-1960	1	Hub-Engine
14	27-1970	1	Hub-Pump
15	92-9764	1	HYD Pump ASM
16	3253-21	2	Washer-Lock
17	323-8	2	Screw-HH
18	340-105	1	Fitting-HYD, 90°
18:1	237-80	1	O-Ring
18:2	237-30	1	O-Ring
19	322-4	2	Screw-HH
20	32128-20	2	Nut-HF

Ref. No.	Part No.	Qty.	Description
21	83-1940-01	1	Guard-Pump
22	322-1	2	Screw-HH
23	3256-3	4	Washer-Flat

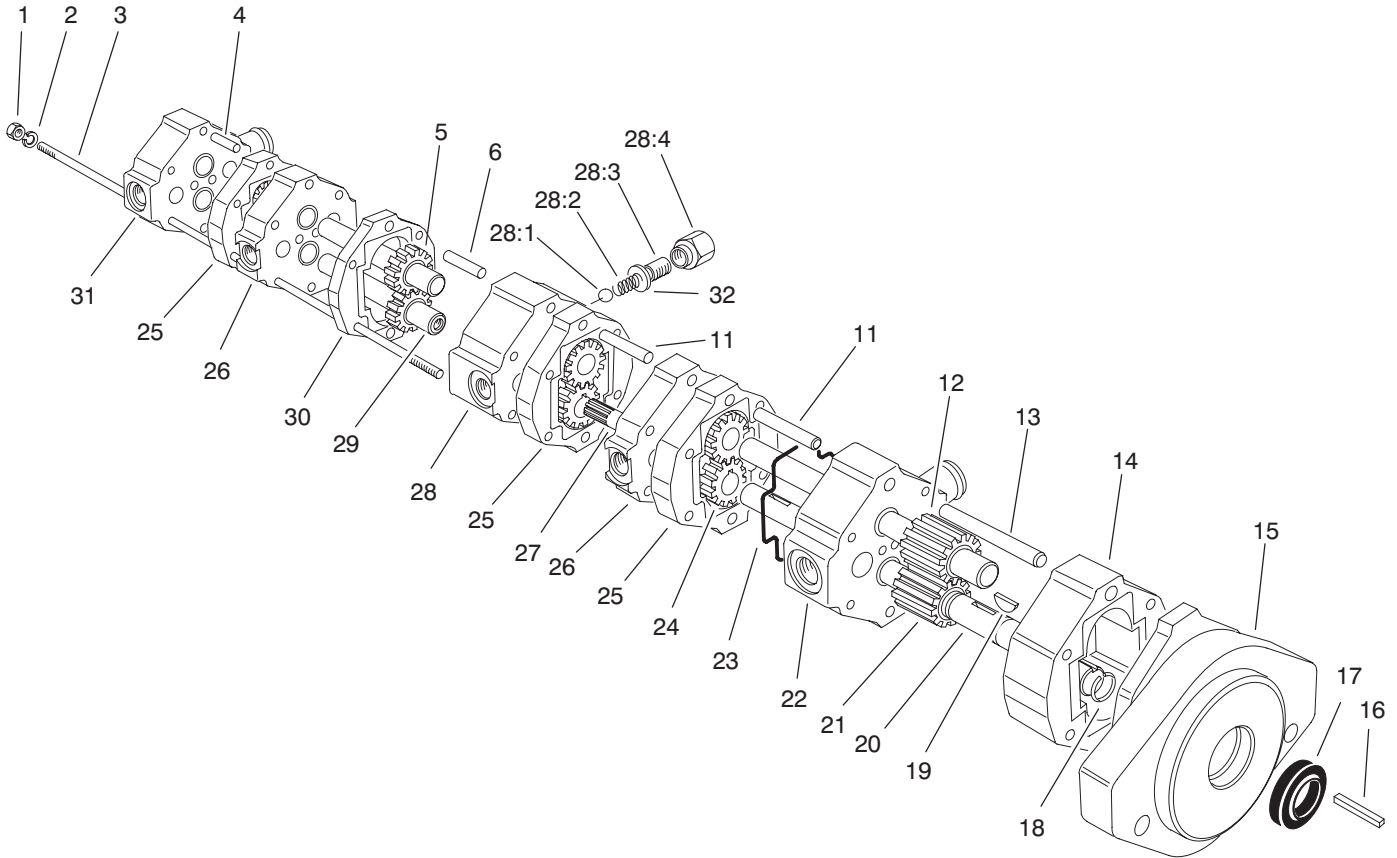

Sheet No.: B2
T-3374

Hydraulic Pump Assembly No. 92-9764

Ref. No.	Part No.	Qty.	Description
1	3217-6	4	Nut-Hex
2	354-16	4	Washer
3	354-17	4	Stud
4	354-11	2	Dowel
5	354-9	1	Idler Shaft And Gear ASM
6	354-12	2	Dowel
11	354-13	4	Dowel
12	92-9774	1	Shaft
13	354-14	2	Pin-Dowel
14	92-9766	1	Plate-Gear
15	354-2	1	Body ASM
16	5-0946	1	Key-Square
17	353-931	1	Seal-Oil
18	353-886	2	Ring-Retaining
19	353-884	4	Key
20	92-9772	1	Shaft-Drive
21	92-9773	1	Gear-59b
22	354-3	1	Bearing Plate ASM
23	353-922	10	Ring-Seal
24	353-967	6	Gear
25	353-969	3	Plate-Gear
26	353-923	2	Plate
27	354-5	1	Adaptor-Splined
28	354-4	1	Bearing Plate ASM
☆28:1		1	Ball-Valve

Ref. No.	Part No.	Qty.	Description
☆28:2		1	Spring-Compression
☆28:3		1	Adjuster-Valve
☆28:4		1	Cap-Adjuster, Valve
29	354-8	1	Drive Shaft And Gear ASM
30	354-6	1	Plate-Gear
31	354-7	1	Pump Cover ASM
32	354-35	1	Gasket

☆ Not serviced separately

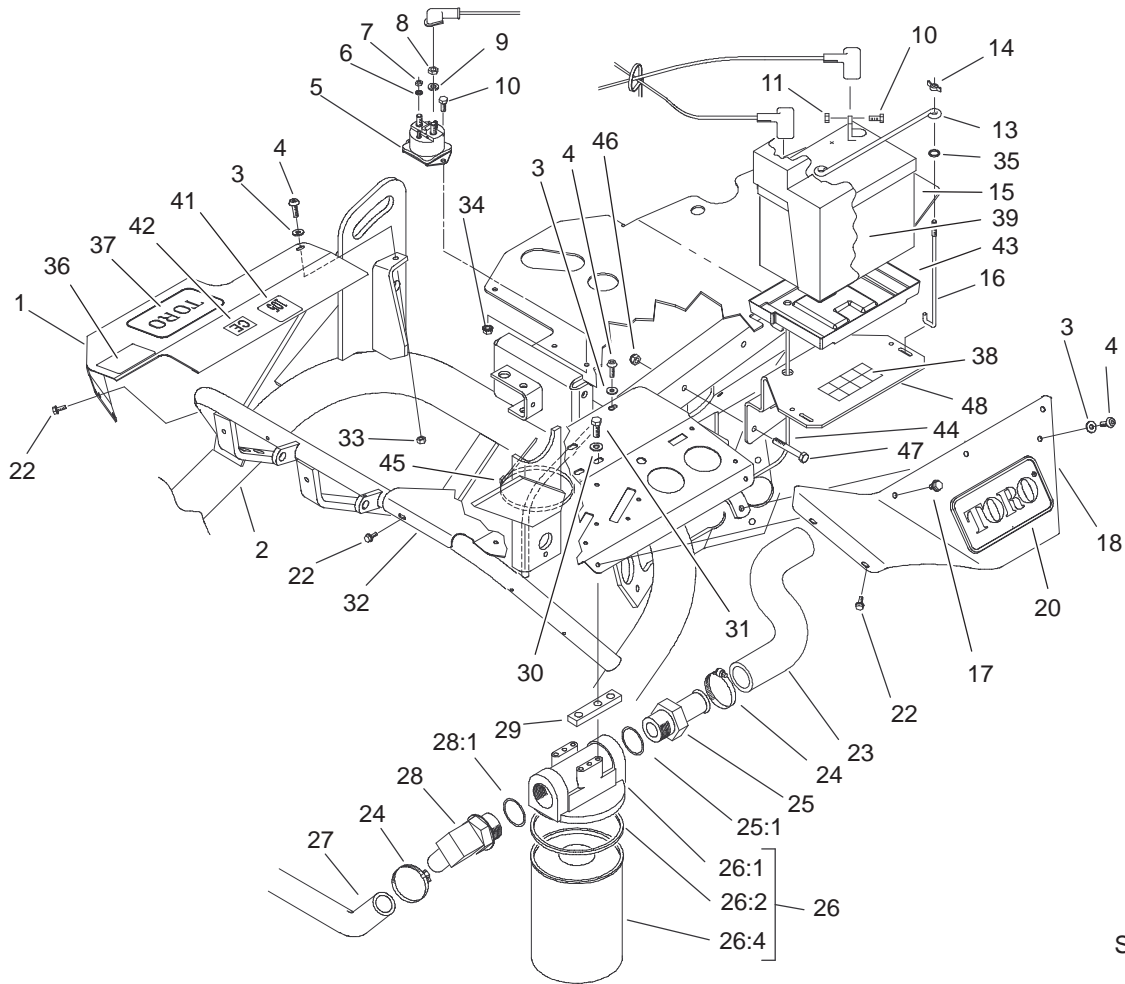

Sheet No.: 13

Frame Assembly

Ref. No.	Part No.	Qty.	Description
1	94-2694-01	1	Cover-RH
2	106-6365-01	1	Frame ASM
3	3256-1	3	Washer-Flat
4	3274-69	3	Screw-HSBH
5	28-4210	1	Solenoid
6	3254-1	2	Washer-Lock, Int
7	3219-14	2	Nut-Hex
8	3218-13	2	Nut-Jam
9	3253-4	2	Washer-Lock
10	321-3	4	Screw-HH
11	3217-5	2	Nut-Hex
13	100-6434	1	Rod-Battery, Hold Down
14	32103-22	2	Nut-Wing
15	104-8162	1	Battery
16	100-6435	2	Post-Battery
17	46-8560	3	Screw-HHF
18	83-0840-01	1	Shield-Cover, Valve
20	105-9751	1	Decal-Toro Logo
22	32104-116	5	Screw
23	95-7119	1	Hose-Line, Return
24	2412-34	3	Clamp-Hose
25	353-563	1	Fitting-HYD, Straight
25:1	237-101	1	O-Ring
☆26		1	Filter And Head ASM
26:1	44-5560	1	Head-Filter, Oil

Ref. No.	Part No.	Qty.	Description
26:2	72-3850	1	Seal-Filter, Oil
26:4	74-3570	1	Filter
27	68-5880	1	Hose-HYD
28	353-564	1	Fitting-90°
28:1	237-101	1	O-Ring
29	27-2380	2	Spacer
30	3256-23	4	Washer-Flat
31	322-4	4	Screw-HH
32	83-0830-01	1	Panel-Control, Upper
33	3296-16	3	Nut-Lock, NI
34	32149-2	2	Nut
35	237-143	2	O-Ring
36	93-8065	1	Decal-Traction
37	67-1300	1	Decal-Toro
38	93-7276	1	Decal-Danger
39	106-9062	1	Cover-Battery
41	105-4674	1	Decal-Noise, Ce
42	93-7252	1	Decal-International
43	106948	1	Tray-Battery
44	98-0601	1	Tube-Drain, Battery
45	3290-379	1	Tie-Cable
46	3296-29	2	Nut-Lock, NI
47	322-11	2	Screw-HH
48	104-2064-03	1	Battery Base ASM

☆ Not serviced separately

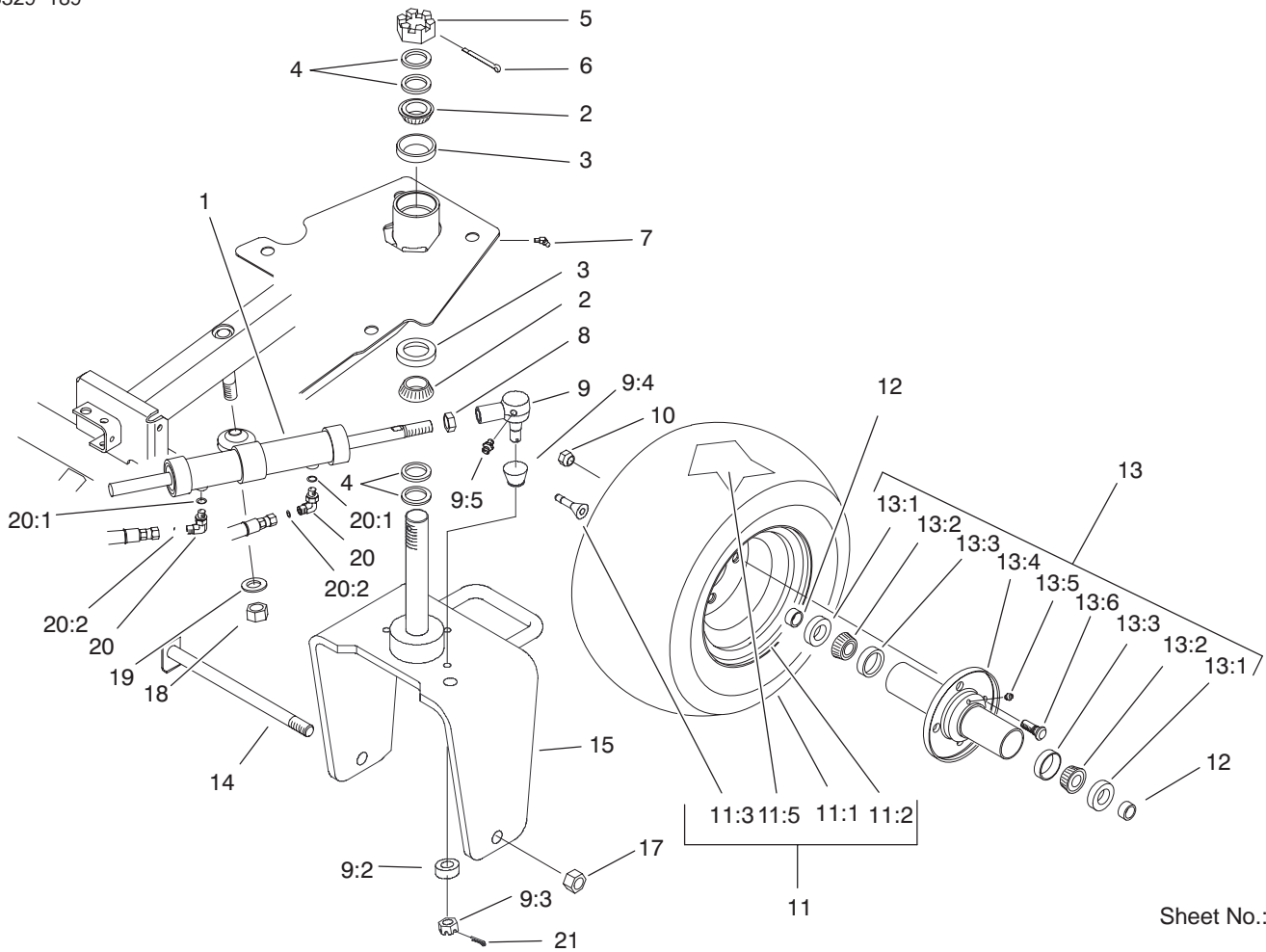

Sheet No.: 14

Rear Wheel Assembly

Ref. No.	Part No.	Qty.	Description
1	83-2330	1	Cylinder-Steering
2	254-70	2	Bearing-Cone
3	254-61	2	Bearing-Cup
4	18-6320	4	Washer-Steering
5	32136-9	1	Nut-Hex, Slot
6	3272-37	1	Pin-Cotter
7	302-11	1	Fitting-Lube, 45°
8	84-5300	1	Nut-Jam
9	105-7841	1	Rod End ASM
9:2	105-7942	1	Spacer
9:3	32136-2	1	Nut-SHH
9:4	105-7835	1	Seal
9:5	302-5	1	Fitting-Grease
10	242-50	4	Nut-Lug
☆11		1	Wheel And Tire ASM
11:1	28-3680	1	Tire
11:2	217-60	1	Rim
11:3	232-27	1	Stem-Valve
11:5	232-37	1	Tube
12	74-3730	2	Spacer-Spindle, Rear
13	72-9710	1	Hub-Tire, Sulky
13:1	253-111	2	Seal-Oil
13:2	254-78	2	Bearing-Cone
13:3	254-79	2	Bearing-Roller, Cup
13:4	75-9440	1	Hub ASM
13:5	302-55	1	Zerk

Ref. No.	Part No.	Qty.	Description
13:6	10-6830	4	Stud-Type, Drive
14	5-3934	1	Bolt-Caster
15	95-5952-01	1	Fork-Castor
17	3296-67	1	Nut-Lock NI
18	3217-12	1	Nut-Hex
19	3256-28	1	Washer-Flat
20	340-132	2	Fitting-HYD, 90°
20:1	237-78	1	O-Ring
20:2	237-21	1	O-Ring
21	3272-12	1	Pin-Cotter

☆ Not serviced separately

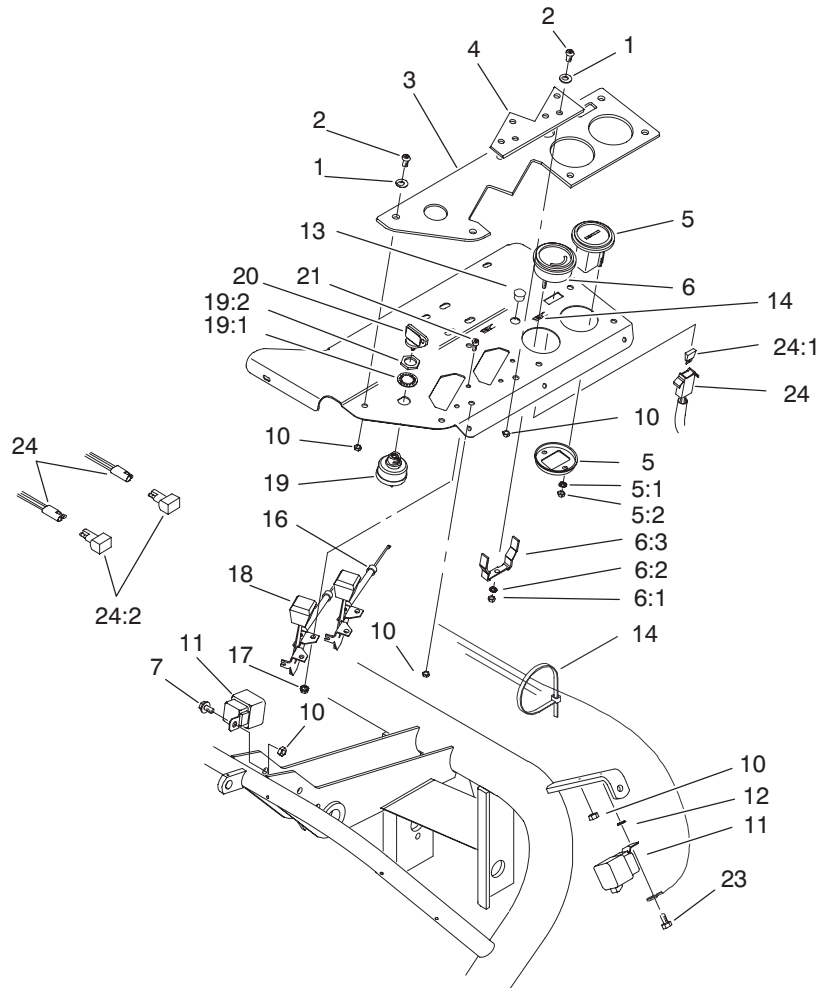

Sheet No.: 15

Control Panel Assembly

Ref. No.	Part No.	Qty.	Description
1	3256-1	8	Washer-Flat
2	3274-69	8	Screw-HSBH
3	93-8061	1	Panel-Control
4	83-2030	1	Plate-Filler
5	66-2950	1	Gauge-Hourmeter
5:1	3255-20	2	Washer-Lock
5:2	3217-25	2	Nut-Hex
6	98-2160	1	Voltmeter
6:1	3217-27	1	Nut-Hex
6:2	3255-25	1	Washer-Lock
6:3	78-0080	1	Clamp-Mounting
7	321-4	1	Screw-HH
10	3296-16	9	Nut-Lock, NI
11	70-1480	2	Relay
12	3255-7	1	Washer-Lock/Ext
13	2410-64	1	Plug-Button
14	3290-378	3	Tie-Cable
16	83-0040	1	Control-Choke
17	3296-27	4	Nut-Lock NI
18	83-0030	1	Control-Throttle
19	88-9830	1	Key Switch ASM
19:1	3254-5	1	Washer-Tooth
19:2	218-461	1	Nut-HH
20	63-8360	2	Key-Ignition
21	3273-26	4	Screw-HSH
23	32104-95	1	Screw-HWH

Ref. No.	Part No.	Qty.	Description
24	104-2058	1	Harness-Wire, Main
24:1	218-578	1	Fuse-10 Amp
24:2	100-4918	2	Diode
*24:3	106-2790	1	Link-Fusible
*24:4	106-2791	1	Link-Fusible

* Not illustrated

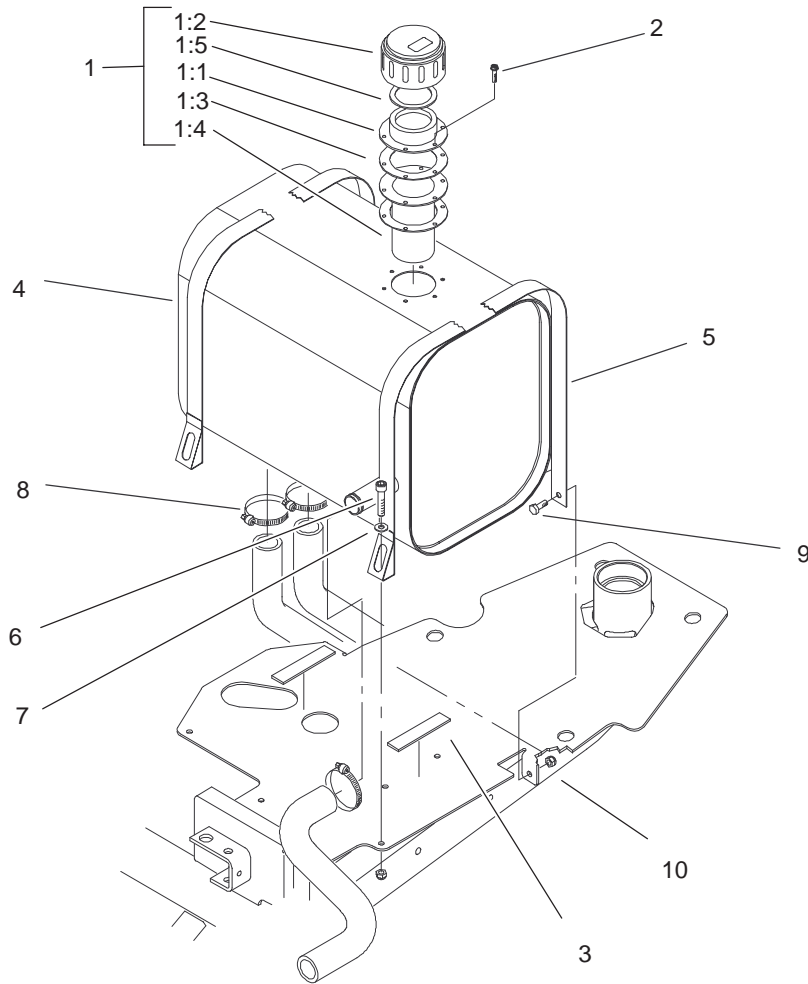

Sheet No.: 16

Hydraulic Reservoir Assembly

Ref. No.	Part No.	Qty.	Description
1	62-2570	1	Filler Cap ASM
1:1	353-961	1	Flange
1:2	353-962	1	Cap ASM
1:3	353-963	2	Gasket
1:4	62-2610	1	Strainer-Cap, Filler
1:5	76-1720	1	Gasket-Cap, Filler
2	32144-34	6	Screw-Forming, Thread
3	95-5951	2	Strip-Seal
4	95-7118	1	Tank-Hydraulic
5	27-2400	2	Reservoir Strap ASM
6	3274-19	2	Screw-HSH
7	3256-22	2	Washer-Flat
8	2412-34	3	Clamp-Hose
9	321-3	2	Screw-HH
10	3296-16	4	Nut-Lock, NI

Ref. No.	Part No.	Qty.	Description

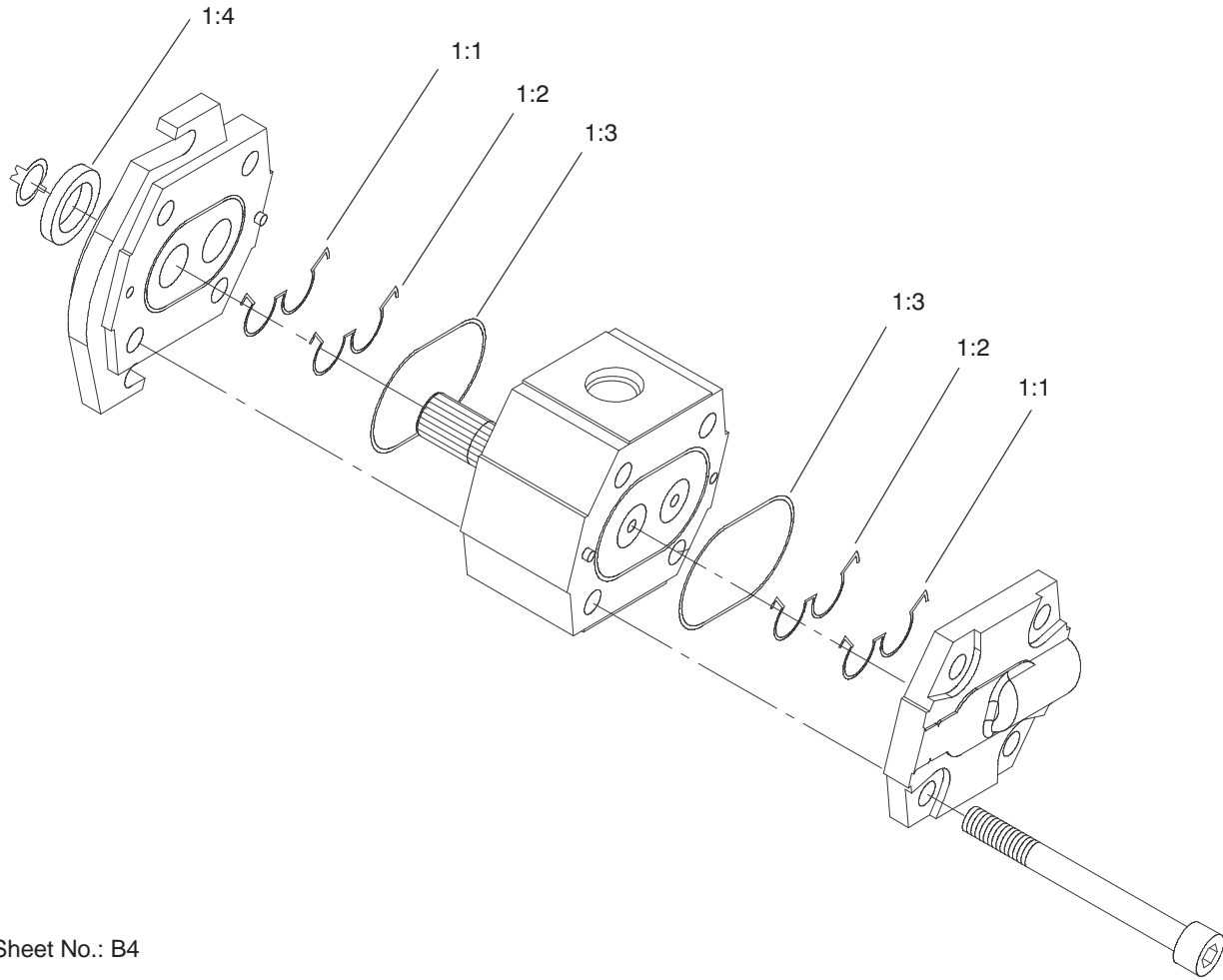

Sheet No.: B4

Hydraulic Motor Assembly No. 105-9770

Ref. No.	Part No.	Qty.	Description
1	106-6362	1	Kit-Seal
☆1:1		2	Seal-Extrusion, Anti
☆1:2		2	Seal-Pressure
			Loading
☆1:3		2	O-Ring
☆1:4		1	Seal-Shaft

Ref. No.	Part No.	Qty.	Description

☆ Not serviced separately

BK BLACK
 BN BROWN
 BU BLUE
 FL FUSIBLE LINK
 GY GRAY
 OR ORANGE
 PU PURPLE
 R RED
 W WHITE
 Y YELLOW
 SP SPLICE

STOP — NONE
 RUN — B++A; X+Y
 START — B++S

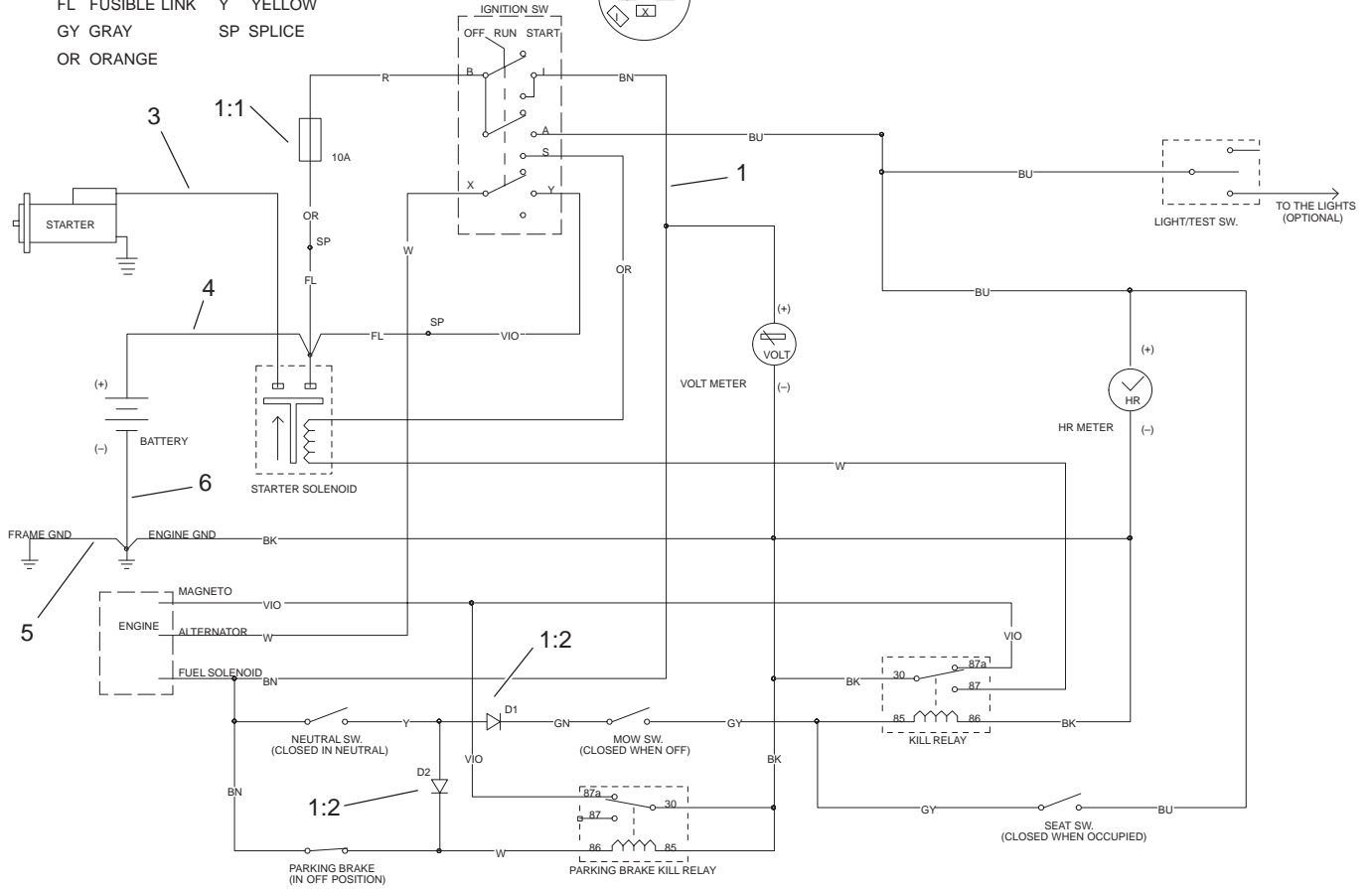
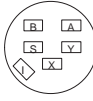

Electrical Schematic

Ref. No.	Part No.	Qty.	Description
1	104-2058	1	Harness-Wire, Main
1:1	218-578	1	Fuse-10 Amp
1:2	100-4918	2	Diode
*1:3	106-2790	1	Link-Fusible
*1:4	106-2791	1	Link-Fusible
3	98-2161	1	Cable-Battery, Positive
4	95-7144	1	Positive Cable ASM
*4:2	28-8080	1	Boot-Terminal
*4:3	83-2430	1	Boot-Terminal
5	83-1150	1	Engine Ground Wire ASM
6	98-0604	1	Negative Cable ASM
*6:2	98-0603	1	Boot-Terminal

Ref. No.	Part No.	Qty.	Description

* Not illustrated

Hydraulic Schematic

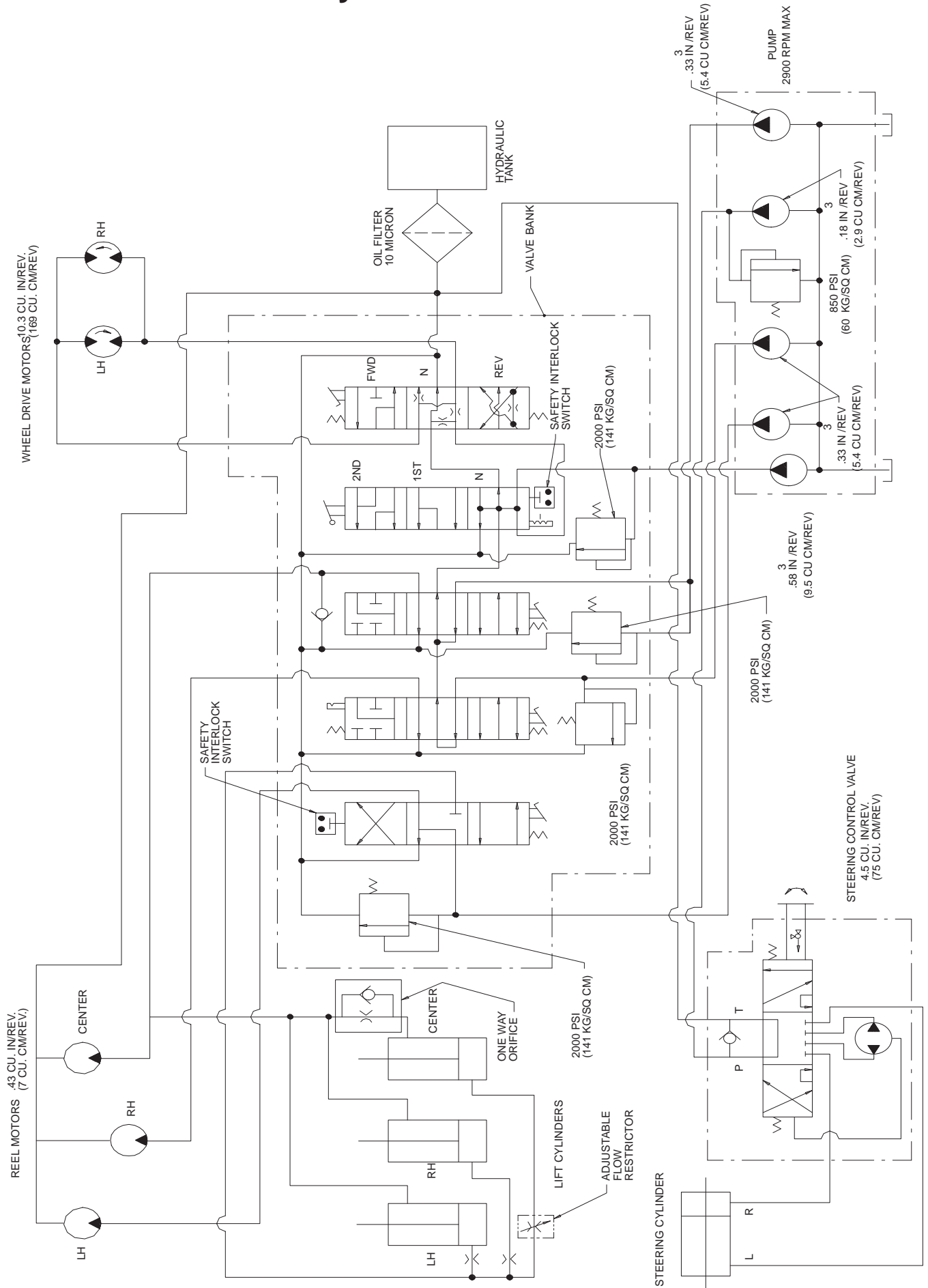

1019 LABEL KIT

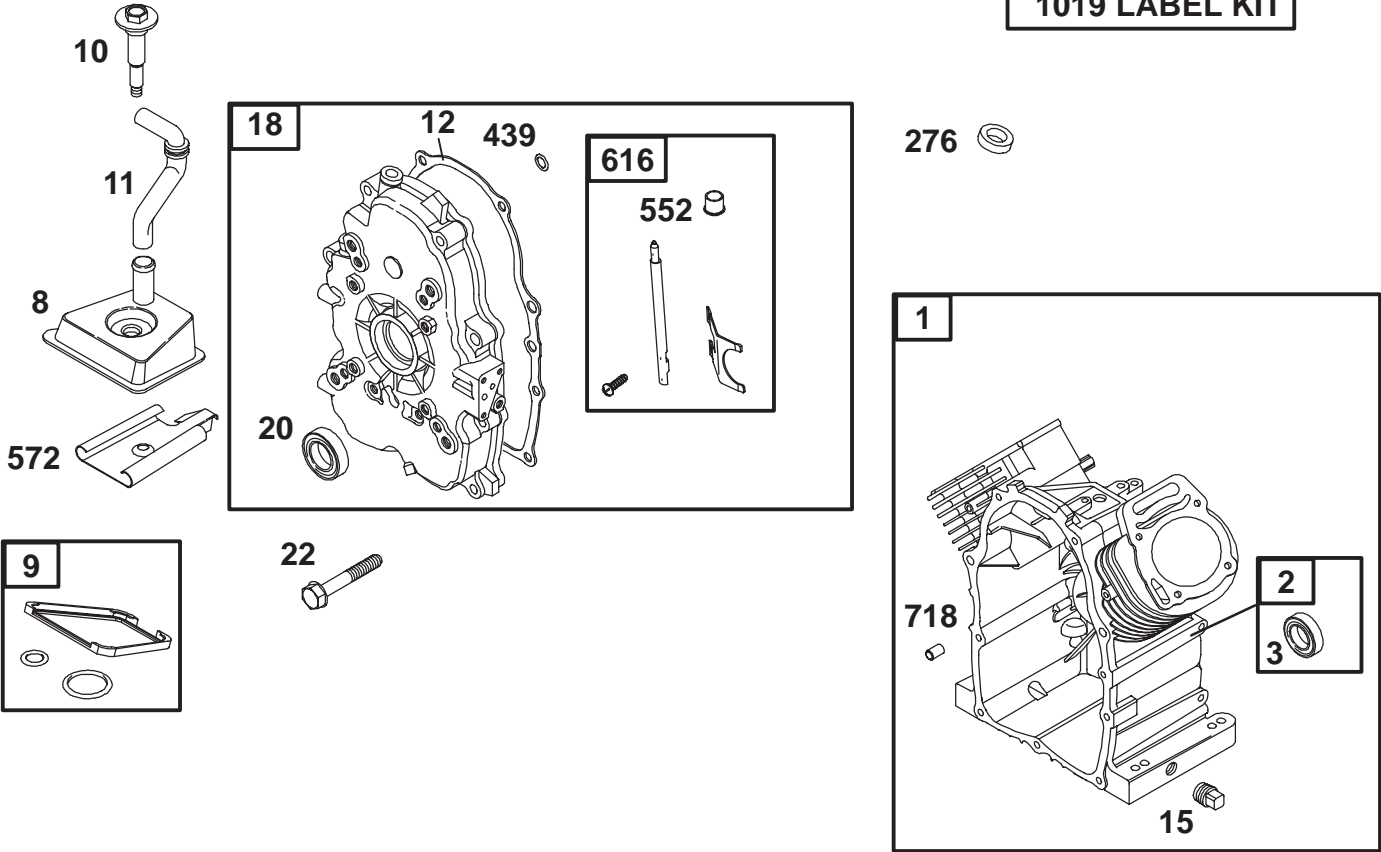

Assemblies include all parts shown in frames.

Cylinder Assembly Briggs and Stratton Model 350447-1331-E1

Ref. No.	Part No.	Qty.	Description
1	692544	1	Cylinder Assembly
2	808534	1	Bearing/Seal Kit
★3	805101	1	Oil Seal
8	808984	1	Breather Assembly
△★9	809094	1	Valve Cover Gasket
10	690751	1	Screw (Breather Assembly)
11	806083	1	Breather Tube
★12	691684	1	Crankcase Gasket
15	690946	1	Oil Drain Plug
18	808847	1	Crankcase Cover
★20	805049	1	Oil Seal
22	692540	1	Screw (Crankcase Gasket)
276	690704	1	Sealing Washer
★439	692154	1	O Ring Seal (Crankcase Cover)
552	806686	1	Governor Crank Bushing
572	690686	1	Breather Baffle
616	806685	1	Governor Crank
718	806469	1	Locating Pin
1019	808036	1	Label Kit

Ref. No.	Part No.	Qty.	Description

△ Included in Valve Gasket Set-Ref. 1095.

★ Included in Engine Gasket Set-Ref. 358.

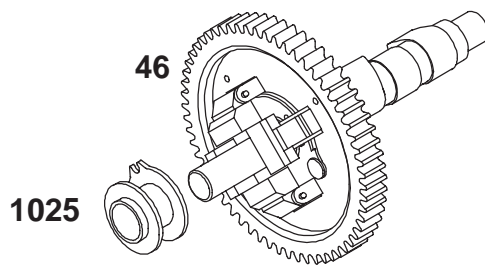
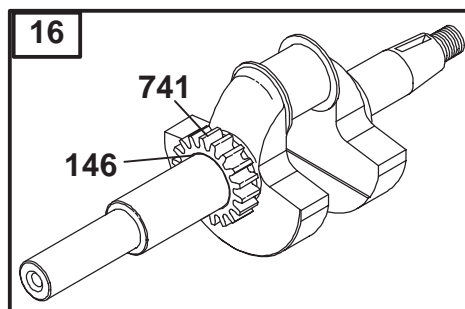
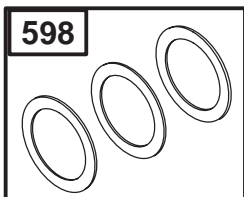
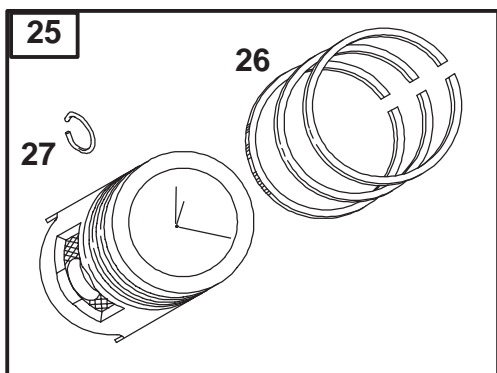
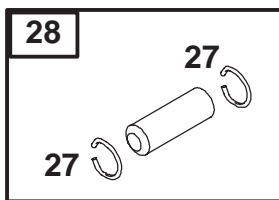
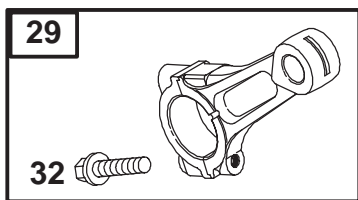

Assemblies include all parts shown in frames.

Crankshaft Assembly Briggs and Stratton Model 350447-1331-E1

Ref. No.	Part No.	Qty.	Description
16	692171	1	Crankshaft
17	690752	1	Ball Bearing
25	808326	1	Piston Assembly (Standard)
	808336	1	Piston Assembly (.010 O.S.)
	808337	1	Piston Assembly (.020 O.S.)
	808338	1	Piston Assembly (.030 O.S.)
26	807889	1	Ring Set (Standard)
	807994	1	Ring Set (.010 O.S.)
	807995	1	Ring Set (.020 O.S.)
	807996	1	Ring Set (.030 O.S.)
27	690683	1	Piston Pin Lock
28	807886	1	Piston Pin (Standard)
29	807900	1	Connecting Rod (Standard)
	807803	1	Connecting Rod (.020 Undersize)
32	690698	1	Screw (Connecting Rod 1 7/8")
46	691557	1	Camshaft

Ref. No.	Part No.	Qty.	Description
146	691639	1	Timing Key
377	808095	1	Woodruff Key
598	807625	1	End Play Shim
741	691530	1	Timing Gear
1025	690689	1	Governor Spool

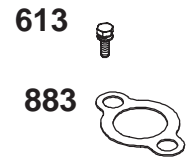
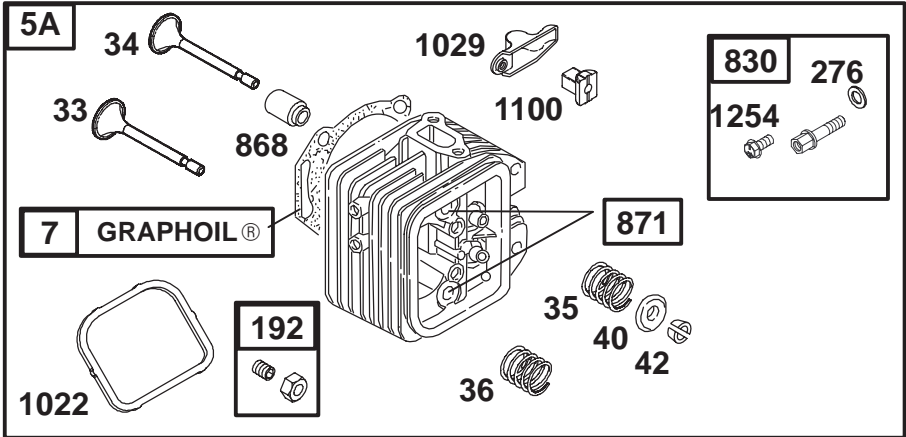
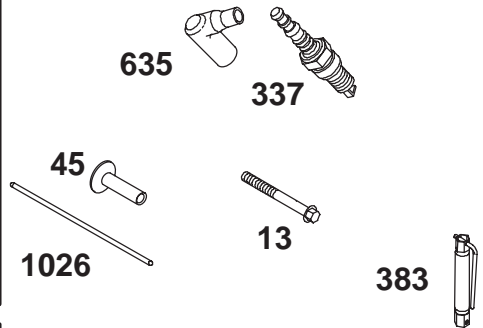
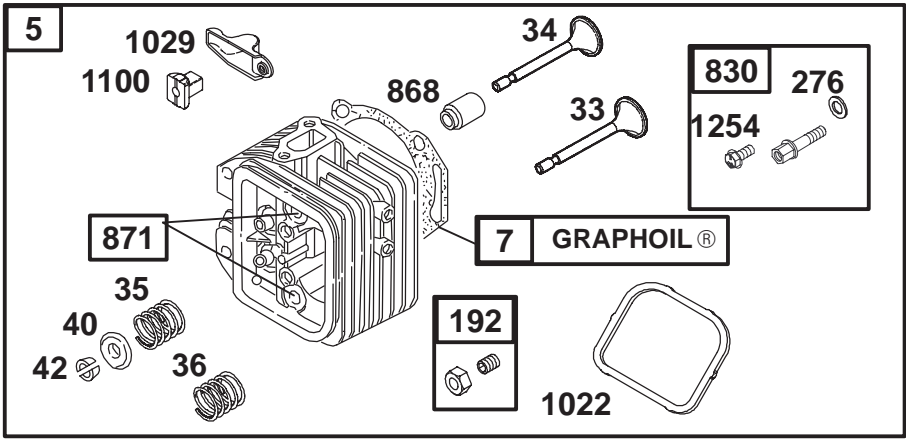

Assemblies include all parts shown in frames.

Cylinder Head Assembly Briggs and Stratton Model 350447-1331-E1

Ref. No.	Part No.	Qty.	Description
5	809185	1	Cylinder Head (No. 1) (Used After Date Code 01120200)
5A	809186	1	Cylinder Head (No. 2) (Used After Date Code 01120200)
Δ★7	690888	1	Cylinder Head Gasket
13	692059	1	Screw (Cylinder Head)
33	807681	1	Exhaust Valve
34	807680	1	Intake Valve
35	692084	1	Valve Spring (Intake)
36	692084	1	Valve Spring (Exhaust)
40	692058	1	Valve Retainer
42	807683	1	Valve Retainer
45	690977	1	Valve Tappet
192	807623	1	Rocker Arm Adjuster
276A	807085	1	Sealing Washer
337	496018	1	Sparkplug
383	19374	1	Sparkplug Wrench

Ref. No.	Part No.	Qty.	Description
613	691902	1	Screw (Exhaust Manifold)
635	692076	1	Sparkplug Boot
830	809157	1	Stud (Rocker Arm)
868	691963	1	Valve Seal
871	692057	1	Bushing Guide
883	691613	1	Exhaust Gasket
Δ★1022	806039	1	Rocker Cover Gasket
1026	691836	1	Push Rod (Steel-Intake)
	691758	1	Push Rod (Aluminum-Exhaust)
1029	691543	1	Rocker Arm
1100	690973	1	Rocker Arm Pivot
1254	807084	1	Screw (Rocker Arm Stud)

Δ Included in Valve Overhaul Gasket Set-Ref. 1095.

★ Included in Engine Gasket Set-Ref. 358.

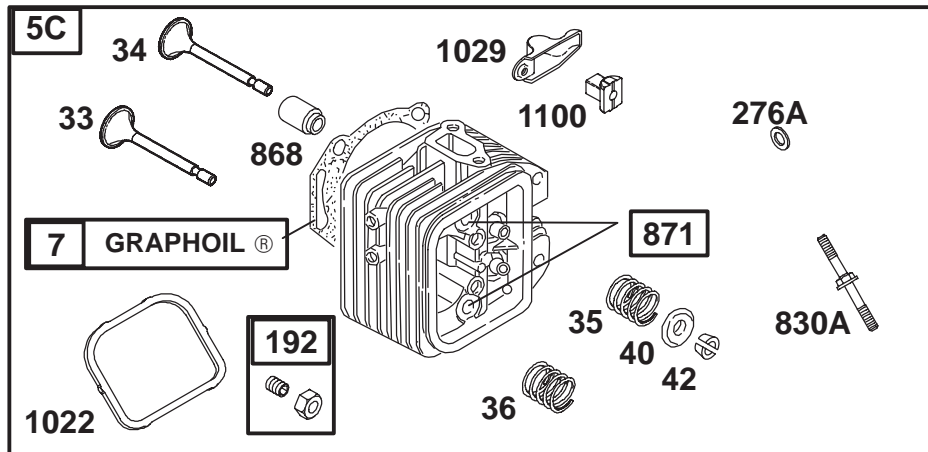
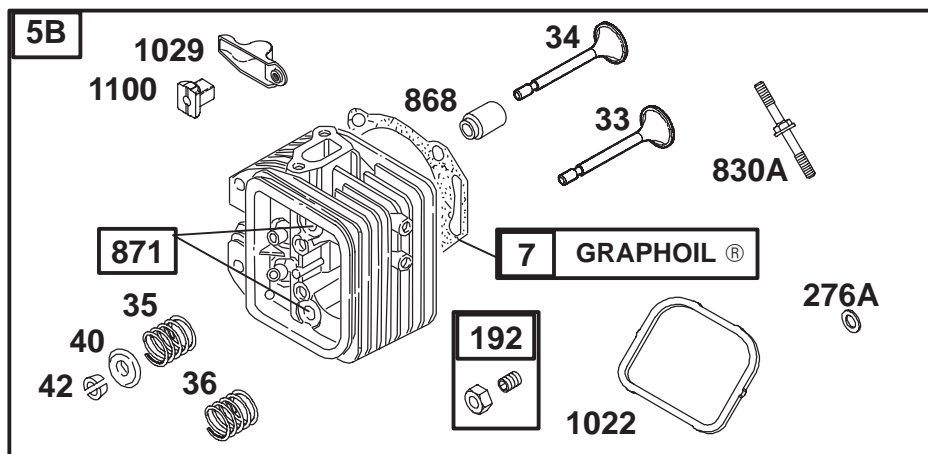

Assemblies include all parts shown in frames.

Cylinder Head Assembly Briggs and Stratton Model 350447-1331-E1

Ref. No.	Part No.	Qty.	Description
5B	808383	1	Cylinder Head (No. 1) (Used Before Date Code 01120300)
5C	808384	1	Cylinder Head (No. 2) (Used Before Date Code 01120300)
Δ★7	690888	1	Cylinder Head Gasket
13	692059	1	Screw (Cylinder Head)
33	807681	1	Exhaust Valve
34	807680	1	Intake Valve
35	692084	1	Valve Spring (Intake)
36	692084	1	Valve Spring (Exhaust)
40	692058	1	Valve Retainer
42	807683	1	Valve Retainer
45	690977	1	Valve Tappet
192	807623	1	Rocker Arm Adjuster
276A	691766	1	Sealing Washer (Used Before Date Code 01120300)

Ref. No.	Part No.	Qty.	Description
830A	691544	1	Stud (Rocker Arm) (Used Before Date Code 01120300)
868	691963	1	Valve Seal
871	692057	1	Bushing Guide
Δ★1022	806039	1	Rocker Cover Gasket
1026	691836	1	Push Rod (Steel-Intake)
	691758	1	Push Rod (Aluminum-Exhaust)
1029	691543	1	Rocker Arm
1100	690973	1	Rocker Arm Pivot

Δ Included in Valve Overhaul Gasket Set-Ref. 1095.

★ Included in Engine Gasket Set-Ref. 358.

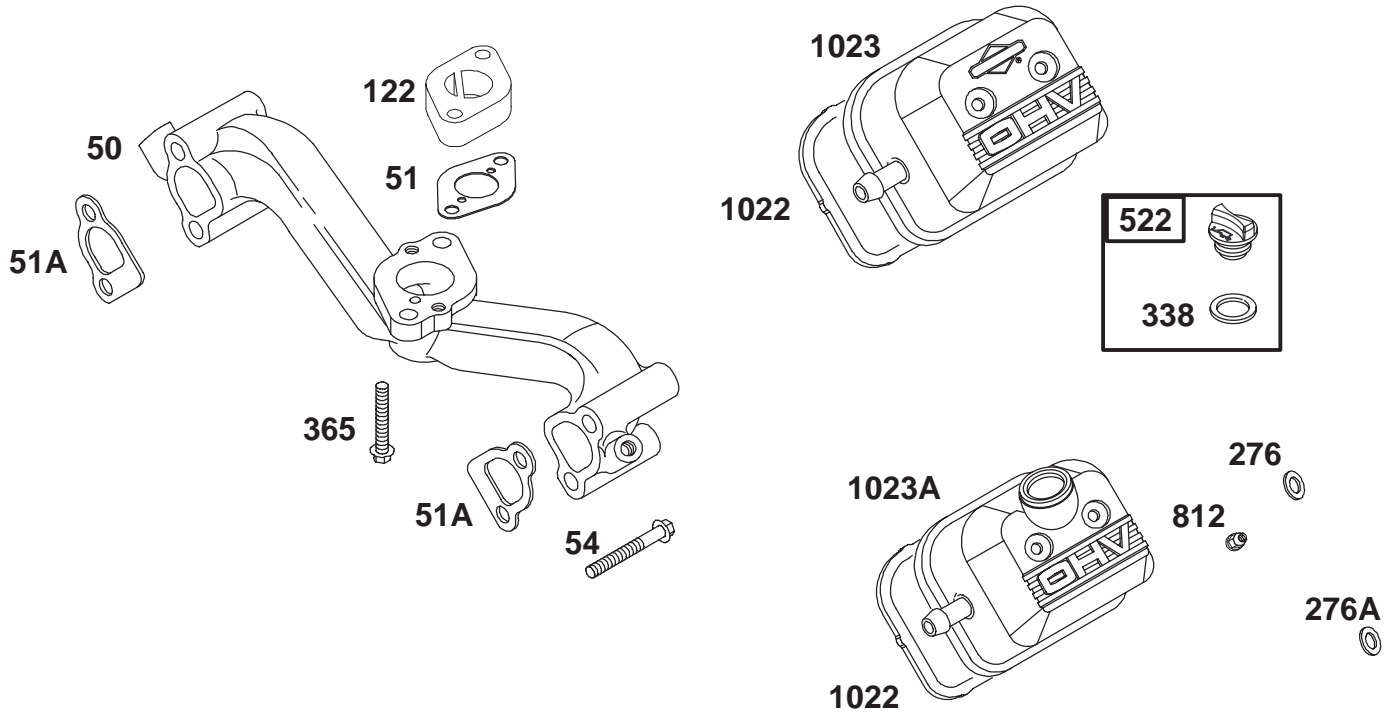

Assemblies include all parts shown in frames.

Intake Manifold and Rocker Cover Assembly Briggs and Stratton Model 350447-1331-E1

Ref. No.	Part No.	Qty.	Description
50	690754	1	Intake Manifold
★51	691694	1	Intake Gasket
Δ★51A	692035	1	Intake Gasket
54	690676	1	Screw (Intake Manifold)
122	690691	1	Carburetor Spacer
276	807085	1	Sealing Washer (Used After Date Code 01120200)
276A	691766	1	Sealing Washer (Used Before Code Date 01120300)
338	691312	1	Dipstick Gasket
365	690711	1	Screw (Carburetor)
522	491832	1	Dipstick/Fill Plug
812	692055	1	Nut (Rocker Arm Cover) (Used Before Code Date 01120300)
Δ★1022	806039	1	Rocker Cover Gasket
1023	691494	1	Rocker Cover
1023A	690910	1	Rocker Cover

Ref. No.	Part No.	Qty.	Description

Δ Included in Valve Overhaul Gasket Set—Ref. 1095.

★ Included in Engine Gasket Set—Ref. 358.

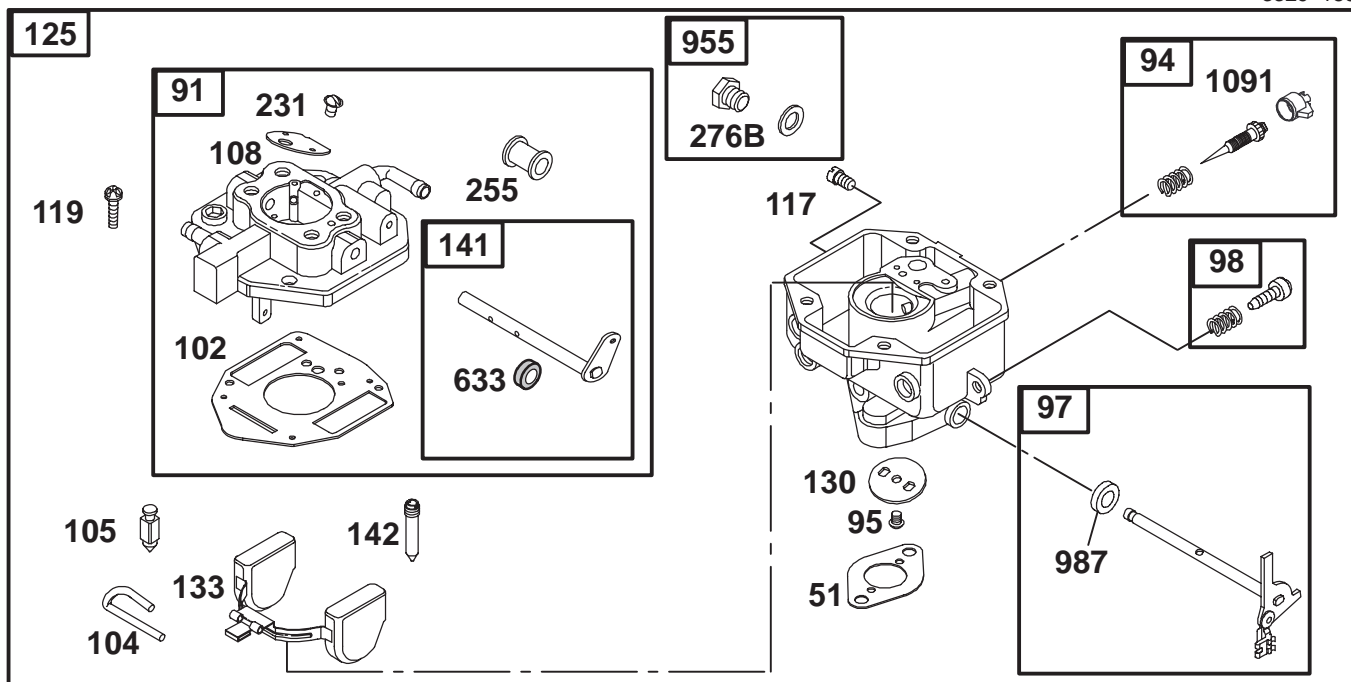

Assemblies include all parts shown in frames.

Carburetor Assembly Briggs and Stratton Model 350447-1331-E1

Ref. No.	Part No.	Qty.	Description
★51	691694	1	Intake Gasket
91	809208	1	Upper Carburetor Body
●94	808257	1	Idle Mixture Kit
●95	690718	1	Screw (Throttle Valve)
97	808973	1	Throttle Shaft Kit
98	808981	1	Idle Speed Kit
●102	692077	1	Carburetor Body Gasket
●104	690723	1	Float Hinge Pin
●105	692078	1	Float Needle Valve
108	690719	1	Choke Valve
109	809096	1	Choke Shaft
●117	808406	1	Main Jet (Standard)
119	690720	1	Screw (Upper to Lower Carburetor Body)
125	809209	1	Carburetor
130	690726	1	Throttle Valve
133	806961	1	Carburetor Float
●142	690725	1	Carburetor Nozzle
●231	690718	1	Screw (Choke Valve)
●255	690721	1	Choke Shaft Bushing
●276B	690724	1	Sealing Washer
276C	806137	1	Sealing Washer
●633	690722	1	Choke/Throttle Shaft

Ref. No.	Part No.	Qty.	Description
			Seal
947	692094	1	Fuel Solenoid
955	807723	1	Carburetor Plug
●987	806131	1	Throttle Shaft Seal
●1091	691516	1	Limiter Cap

● Included in Carburetor Overhaul Kit—Ref. 121.

★ Included in Engine Gasket Set—Ref. 358.

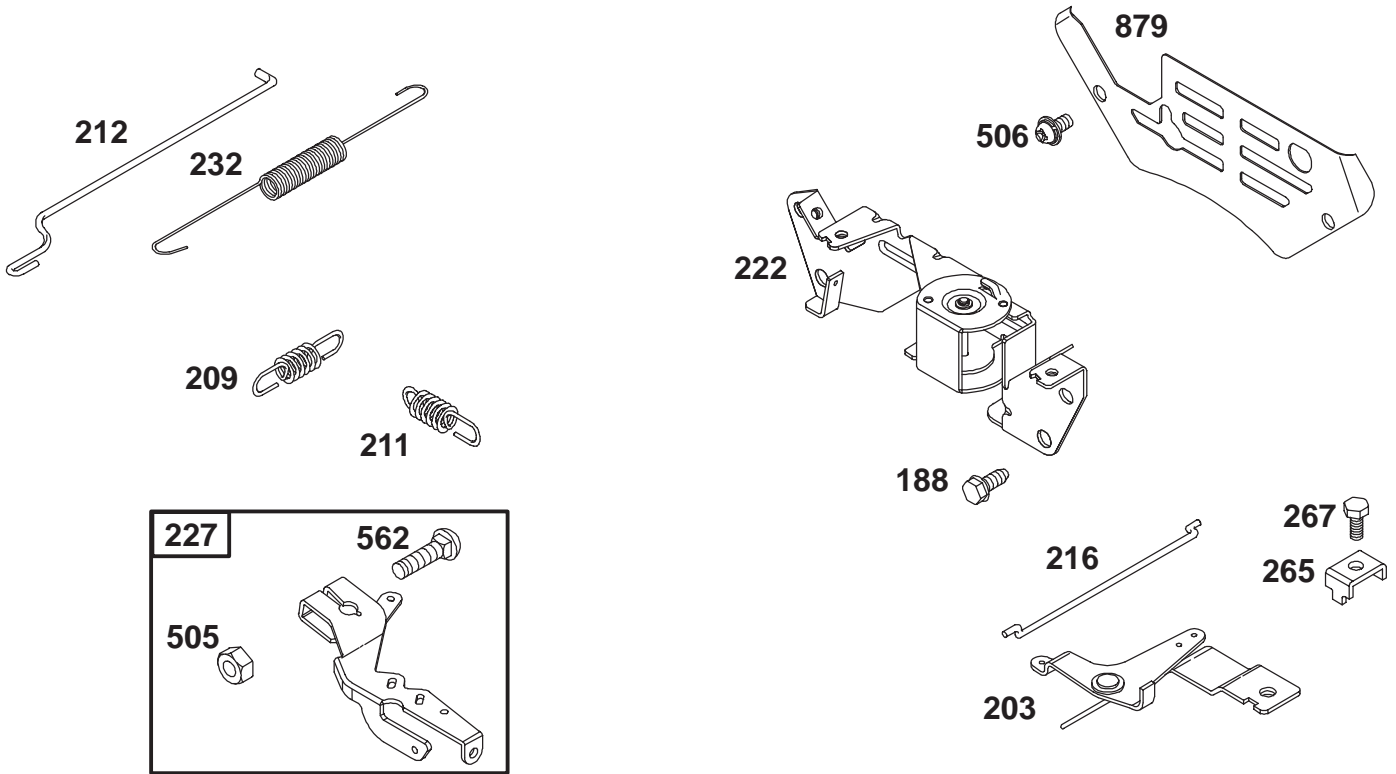

Assemblies include all parts shown in frames.

Governor Assembly Briggs and Stratton Model 350447-1331-E1

Ref. No.	Part No.	Qty.	Description
188	692056	1	Screw (Control Bracket)
203	690923	1	Bell Crank
209	806872	1	Governor Spring
211	806868	1	Governed Idle Spring
	692068	1	Governed Idle Spring (Secondary)
212	690712	1	Throttle Link
216	690705	1	Choke Link
222	808454	1	Control Bracket
227	690236	1	Governor Control Lever
232	692073	1	Governor Link Spring
265	691024	1	Casing Clamp
267	692083	1	Screw (Casing Clamp)
505	690238	1	Nut (Governor Control Lever)
506	690677	1	Screw (Carburetor Cover)
562	690239	1	Bolt (Governor Control Lever)
879	690757	1	Carburetor Cover

Ref. No.	Part No.	Qty.	Description

★ Included in Engine Gasket Set-Ref. 358.

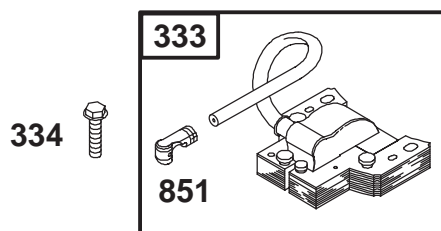
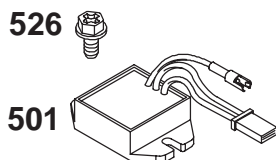
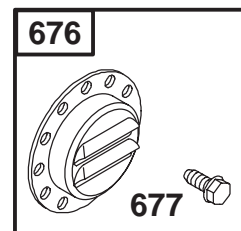
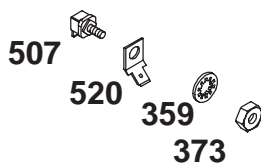
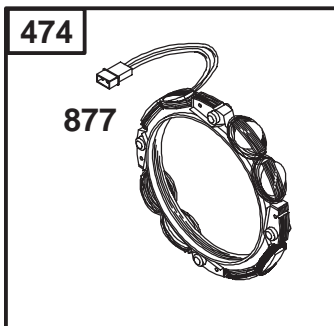

Assemblies include all parts shown in frames.

Alternator Assembly Briggs and Stratton Model 350447-1331-E1

Ref. No.	Part No.	Qty.	Description
333	492341	1	Magneto Armature
334	692066	1	Screw (Magneto Armature)
359	691077	1	Washer (Ground Terminal)
373	691612	1	Nut (Ground Terminal)
474	696458	1	Alternator
501	691185	1	Regulator
507	691972	1	Insulator
520	691084	1	Ground Terminal
526	692067	1	Screw (Regulator)
529	690744	1	Grommet
578	692319	1	Wire Assembly
676	397630	1	Muffler Deflector
677	690661	1	Screw (Muffler Deflector)
729	690586	1	Wire Clip
851	493880	1	Sparkplug Terminal
877	399916	1	Alternator Harness
1054	280275	1	Cable Tie
1119	691552	1	Screw (Alternator)

Ref. No.	Part No.	Qty.	Description

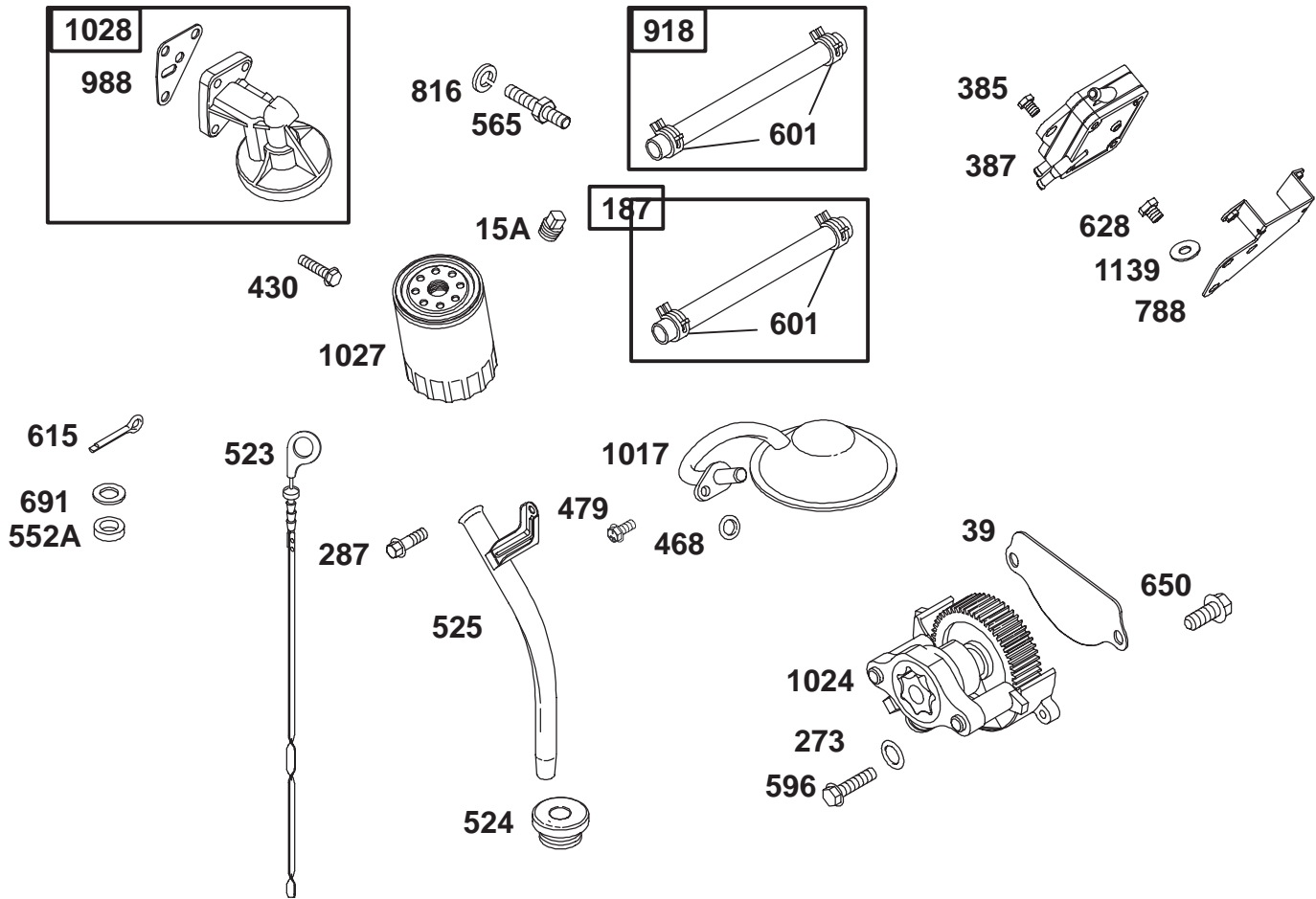

Assemblies include all parts shown in frames.

Fuel Pump, Oil Pump and Dipstick Assembly Briggs and Stratton Model 350447-1331-E1

Ref. No.	Part No.	Qty.	Description
15A	690283	1	Oil Drain Plug
39	690745	1	Oil Deflector
187	691050	1	Fuel Line (Cut to Required Length)
★273	690681	1	O-Ring Seal (Oil Pump)
287	692062	1	Screw (Dipstick Tube)
385	693169	1	Screw (Fuel Pump)
387	808969	1	Fuel Pump
430	690679	1	Bolt (Oil Pump)
★468	690690	1	O-Ring Seal (Oil Pump Screen)
479	807084	1	Screw (Oil Pump Screen)
523	693175	1	Dipstick
524	693172	1	Dipstick Tube Seal
525	693174	1	Dipstick Tube
552A	690701	1	Governor Crank Bushing
565	690682	1	Stud (Oil Filter)
596	691492	1	Screw (Oil Pump)
601	691038	1	Hose Clamp
615	691550	1	Governor Shaft

Ref. No.	Part No.	Qty.	Description
			Retainer
628	692062	1	Screw (Pump Bracket)
650	692539	1	Screw (Oil Deflector)
691	690680	1	Governor Shaft Seal
788	691559	1	Pump Bracket
816	690706	1	Washer (Oil Filter)
918	393815	1	Vacuum Hose
★988	692063	1	Oil Adapter Gasket
1017	690900	1	Oil Pump Screen
1024	693185	1	Oil Pump
1027	492932	1	Oil Filter
1028	808235	1	Oil Filter Adapter
1139	806497	1	Washer (Fuel Pump Bracket)

★ Included in Engine Gasket Set-Ref. 358.

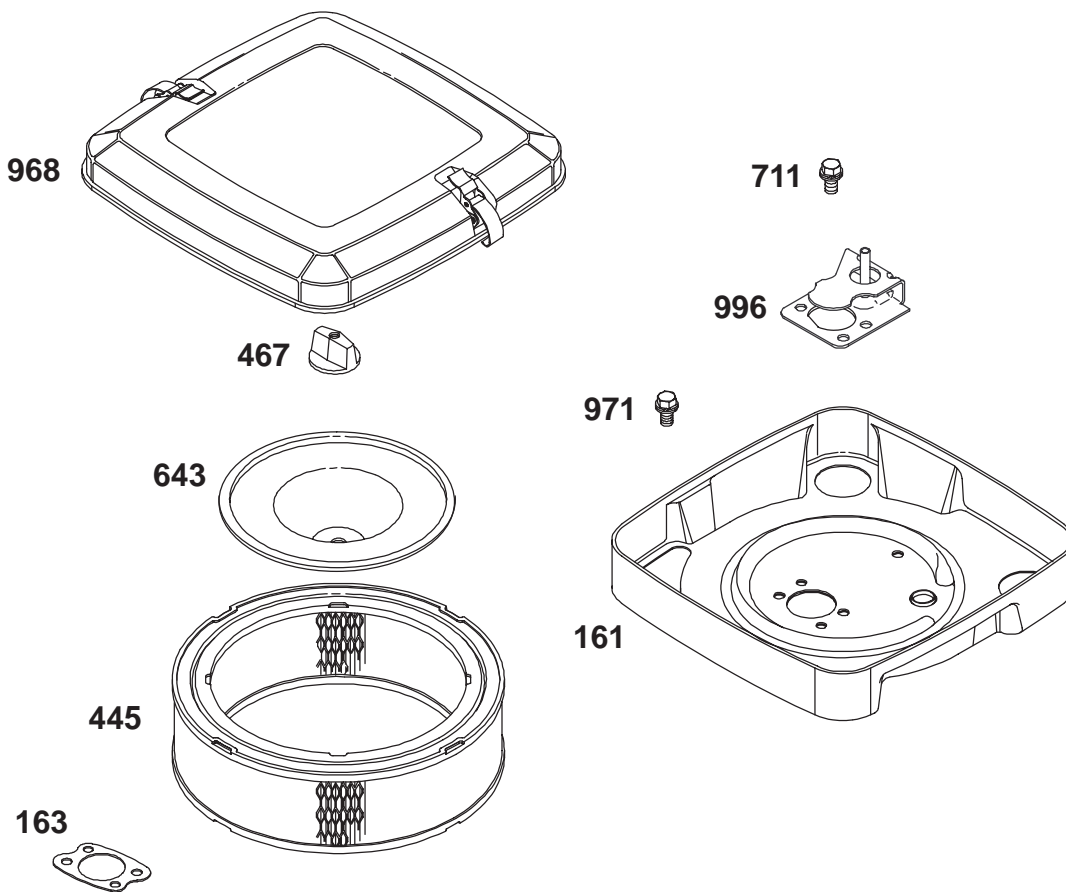

Assemblies include all parts shown in frames.

Air Cleaner Assembly Briggs and Stratton Model 350447-1331-E1

Ref. No.	Part No.	Qty.	Description
161	691561	1	Air Cleaner Base
163	692081	1	Air Cleaner Gasket
445	394018	1	Air Cleaner Cartridge Filter
467	691985	1	Air Cleaner Knob
643	692079	1	Air Filter Retainer
711	692539	1	Screw (Carburetor Shield)
968	692097	1	Air Cleaner Cover
971	692537	1	Screw (Air Cleaner Base)
996	691577	1	Carburetor Shield

Ref. No.	Part No.	Qty.	Description

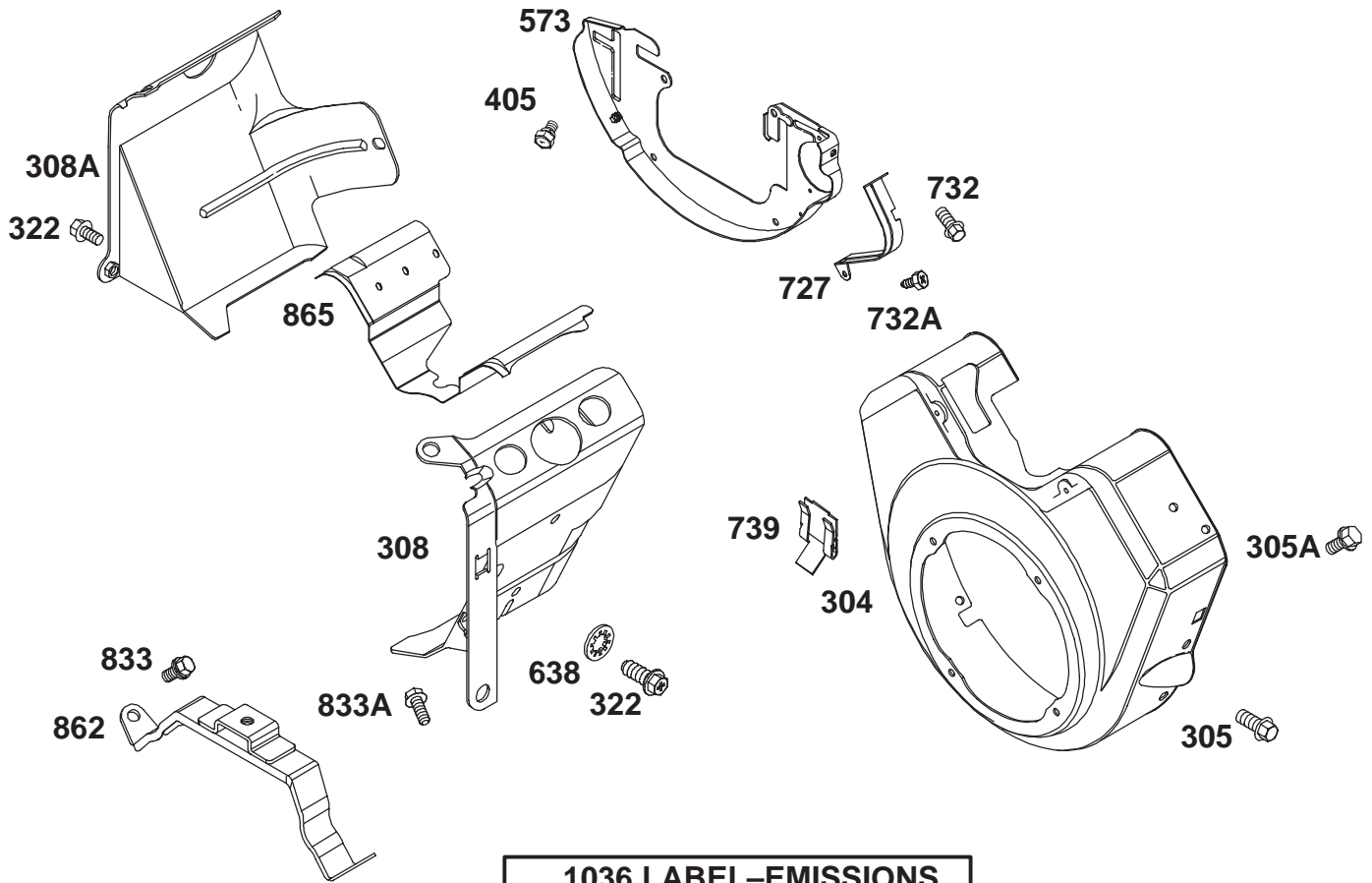

Assemblies include all parts shown in frames.

Blower Housing Assembly Briggs and Stratton Model 350447-1331-E1

Ref. No.	Part No.	Qty.	Description
304	690929	1	Blower Housing
305	692539	1	Screw (Blower Housing)
305A	692056	1	Screw (Blower Housing)
308	806547	1	Cylinder Head Cover (Cylinder #1)
308A	806546	1	Cylinder Head Cover (Cylinder #2)
322	692539	1	Screw (Cylinder Head Cover)
405	807163	1	Screw (Back Plate)
573	690902	1	Back Plate
638	691551	1	Washer (Cylinder Head Cover)
727	690714	1	Starter Drive Cover
732	692539	1	Screw (Starter Drive Cover)
732A	690688	1	Screw (Starter Drive Cover)
739	690451	1	Debris Clip
833	692539	1	Screw (Cleaner Mounting Strap)
833A	690872	1	Screw (Cleaner

Ref. No.	Part No.	Qty.	Description
862	692153	1	Mounting Strap) Cleaner Mounting Strap
865	690750	1	Air Guide Cover
1036	806885	1	Emissions Label

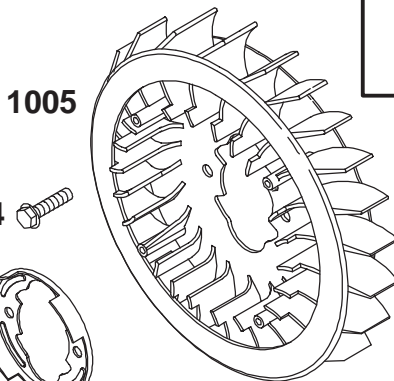
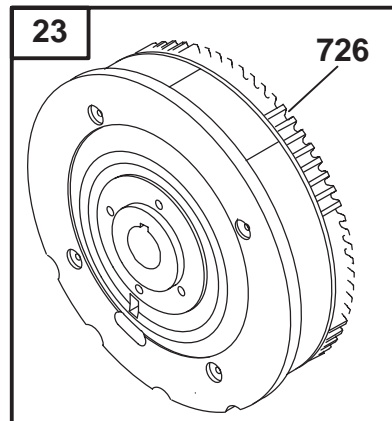
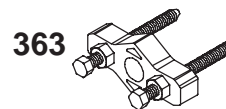
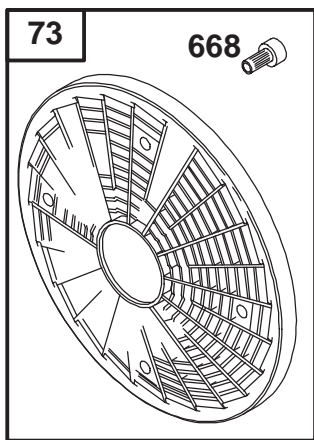

Assemblies include all parts shown in frames.

Flywheel Assembly Briggs and Stratton Model 350447-1331-E1

Ref. No.	Part No.	Qty.	Description
23	808768	1	Flywheel
73	494439	1	Rotating Screen
74	691647	1	Screw (Rotating Screen)
332	690887	1	Nut (Flywheel)
363	19203	1	Flywheel Puller
668	691500	1	Spacer
726		1	Ring Gear (Sold in Flywheel Kit Only, See Ref. 23)
934	691058	1	Screw (Fan Retainer)
1005	690911	1	Flywheel Fan
1006	690452	1	Fan Retainer

Ref. No.	Part No.	Qty.	Description

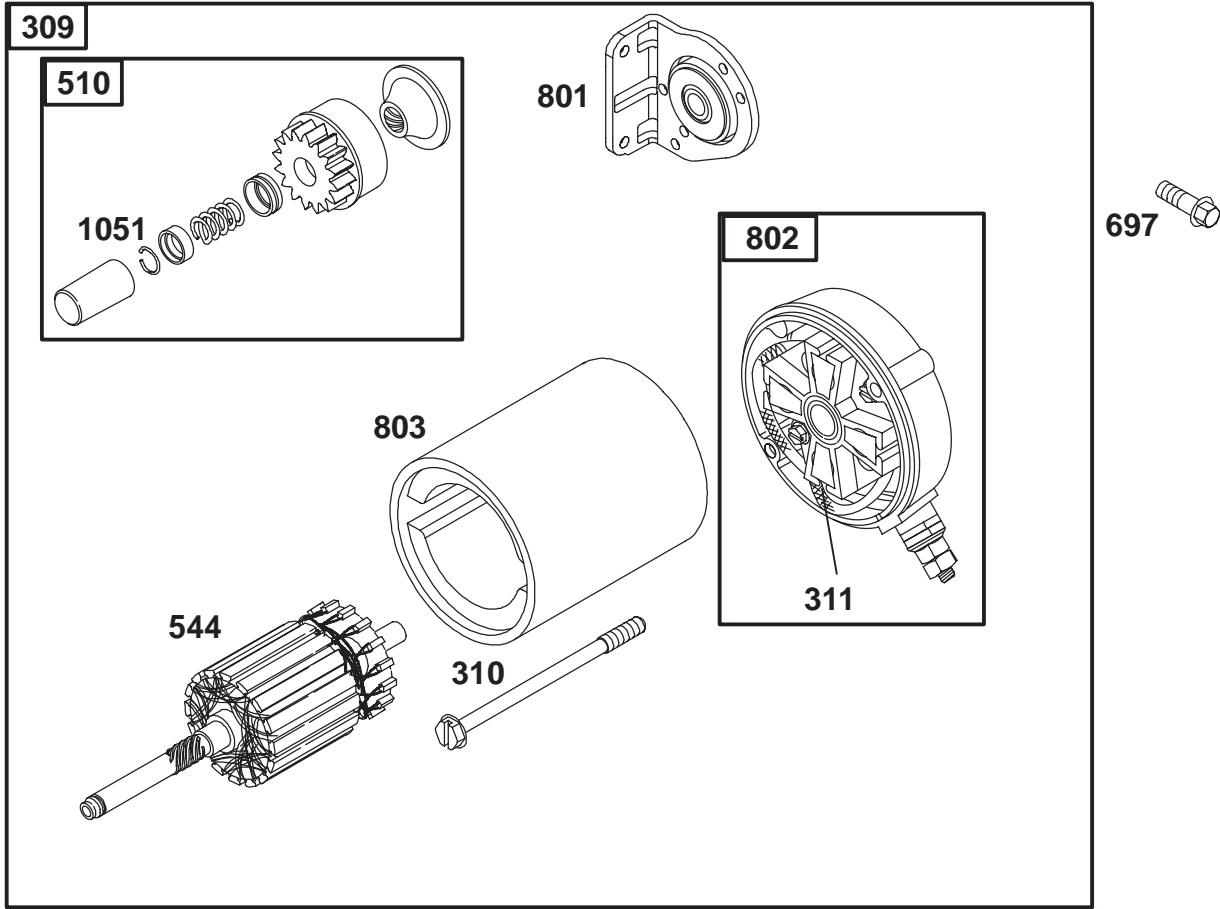

Assemblies include all parts shown in frames.

Starter Assembly Briggs and Stratton Model 350447-1331-E1

Ref. No.	Part No.	Qty.	Description
309	691564		Starter Motor
310	496880	1	Screw (Starter Housing)
311	496887	1	Brush Set
510	496881	1	Starter Drive
544	690855	1	Starter Armature
697	692062	1	Screw (Drive Cap)
801	808778	1	Drive Cap
802	496813	1	End Cap
803	690854	1	Starter Housing
1051	691124	1	Ring-Retaining

Ref. No.	Part No.	Qty.	Description

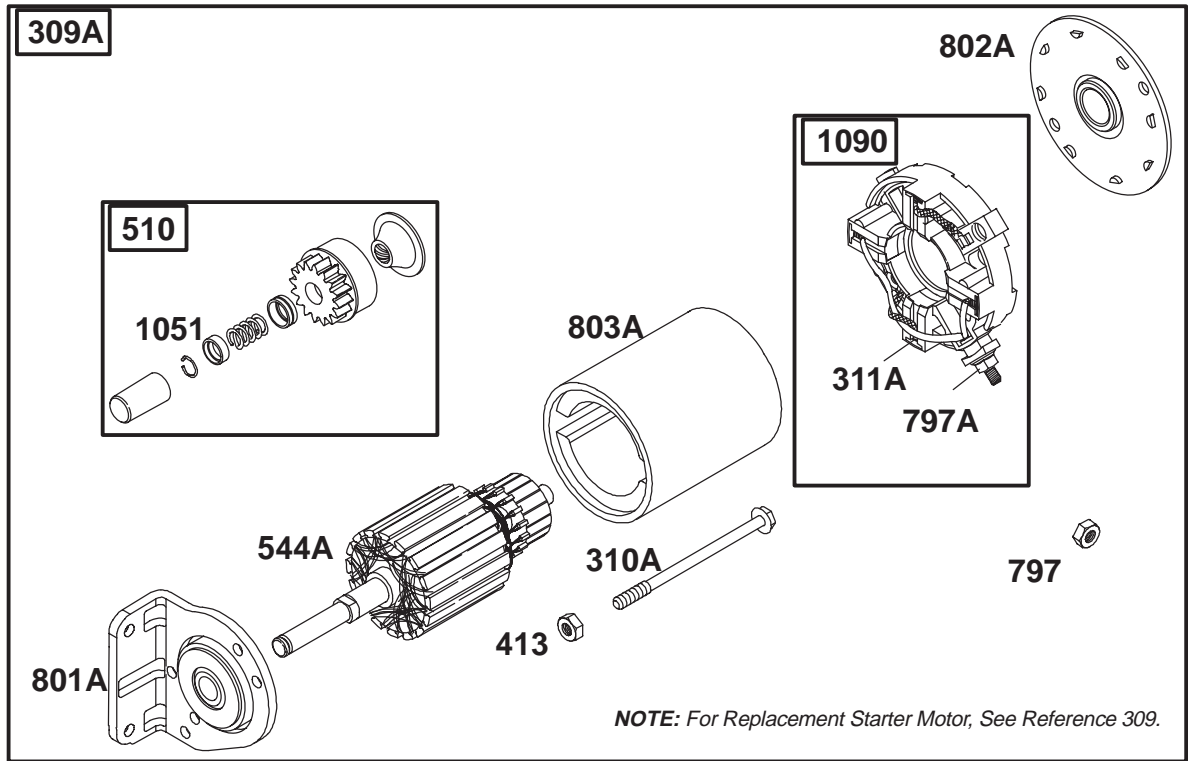

Assemblies include all parts shown in frames.

Starter Assembly Briggs and Stratton Model 350447-1331-E1

Ref. No.	Part No.	Qty.	Description
309A			Starter Motor (For Replacement Starter Motor, See Ref. 309)
310A	690323	1	Screw (Starter Motor)
311A	497608	1	Brush Set
413	693587	1	Nut (Starter Motor)
510	496881	1	Starter Drive
544A	693548	1	Starter Armature
797	691029	1	Nut (Starter Cable)
797A	693167	1	Nut (Starter Cable)
801A	808777	1	Drive Cap
802A	691286	1	End Cap
803A	693547	1	Starter Housing
1051	691124	1	Ring-Retaining
1090	691293	1	Brush Retainer

Ref. No.	Part No.	Qty.	Description

Special Tools Reel Motor Seal Installation Tools

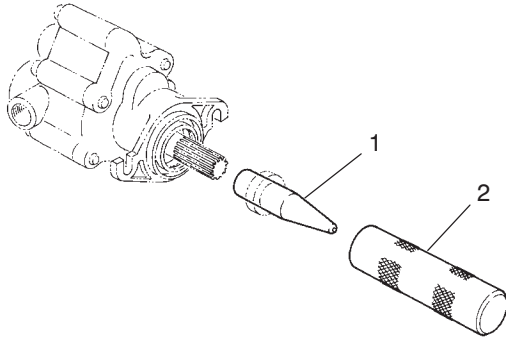

T-0727

Ref. No.	Part No.	Qty.	Description
1	TOR491430	1	Protector-Seal
2	TOR491450	1	Installer-Seal

Bed Knife Screw Tool No. TOR510880

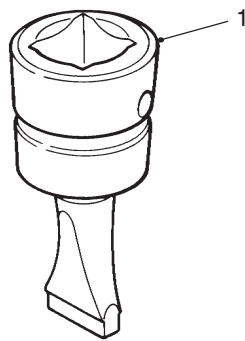

T-0729

Ref. No.	Part No.	Qty.	Description
1		1	Tool-Bed Knife Screw

Bearing Replacement Tool Kit No. TOR238900

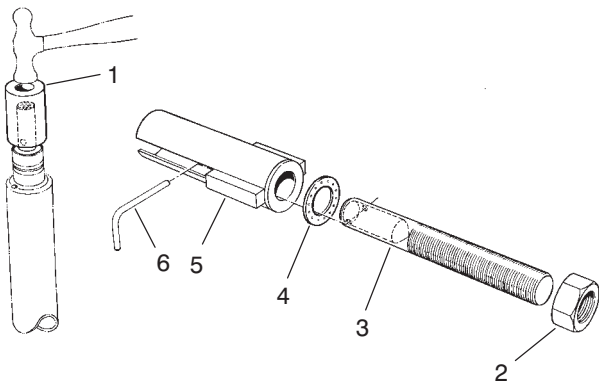

T-0730

Ref. No.	Part No.	Qty.	Description
1	23-8880	2	Driver-Bearing
2	3219-18	1	Nut-Hex
3	23-8840	1	Puller-Bolt
4	22-6090	1	Washer-Thrust
5	23-8850	1	Tube-Support
6	23-8860	1	Pin-Replacement, Bearing

Backlapping Brush Assembly No. 29-9100

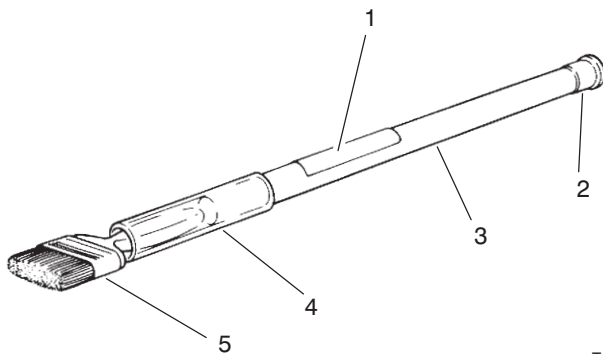

T-0731

Ref. No.	Part No.	Qty.	Description
1	12-9140	1	Decal
2	2410-18	1	Plug
3	29-9080	1	Handle
4	29-9090	1	Hose-Handle
5	36-4310	1	Brush

Note: Special tools may be ordered from: Owatonna Tool Company 2013 4th St. NW Owatonna, MN 55060

Special Tools (Continued)

Alignment Tool No. TOR200120

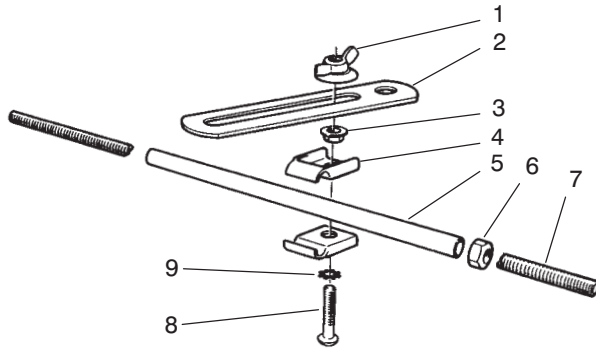

T-0732

Ref. No.	Part No.	Qty.	Description
1	3-4808	1	Nut-Wingl
2	20-0110	1	Bracket-Alignment
3	32123-20	1	Nut-Lock, Flange
4	3-6657	2	Clip-Skid
5	20-0070	1	Tube
6	3219-2	1	Nut-Hex
7	20-0080	1	Rod
8	32122-35	1	Screw-Head, Truss
9	3255-8	1	Washer-Lock, Int. Tooth

**Note: Special tools may be ordered from: Owatonna Tool Company
2013 4th St. NW
Owatonna, MN 55060**

