



## Debris Blower 600

Model No. 44536-23000001 and Up

### Parts Catalog

---

#### Ordering Replacement Parts

To order replacement parts, please supply: the part number, the quantity, and the description of each part desired.

#### Understanding Reference Numbers

Each identified part in an illustration has a reference number. The reference number for a part also appears in the parts list, along with other information about the part.

This catalog uses two special reference number formats, one to indicate parts in a service assembly and another to indicate the quantity of a given part in an illustration.

#### Service Assembly Reference Numbers

Parts in service assemblies have reference numbers in the form **a:b**. The **a** represents the reference number of the entire service assembly and the **b** represents a sequential number unique to each part within the service assembly.

For example, a wheel assembly might be identified by reference number **6**, the tire by **6:1**, the valve by **6:2**, and the wheel by **6:3**. When you order the assembly identified by reference number **6**, you receive all parts identified by reference numbers **6:1**, **6:2**, and **6:3**. However, you may also order any part individually.

Reference numbers of this type appear in illustrations and in part lists.

#### Reference Numbers Indicating Quantity

In an illustration, if a reference number indicates more than one part, the reference number has the form **nX y**. The **n** represents the quantity of the part, the **X** is the multiplication symbol, and the **y** represents the reference number.

For example, in an illustration, the reference number **2X 37** means that two of the parts identified by reference number **37** are indicated.

## Contents

<b>Description</b>	<b>Page</b>	<b>Description</b>	<b>Page</b>
Housing and Impeller Assembly .....	3	Chute and Roller Assembly .....	5
Drive Assembly .....	4		

## Part Description Abbreviations

Part descriptions in this catalog may include the following abbreviations.

<b>Abbreviation</b>	<b>Meaning</b>	<b>Abbreviation</b>	<b>Meaning</b>
AR .....	as required	HYD .....	hydraulic
ASM .....	assembly	INC .....	incorporated
CARR .....	carriage	LH .....	left hand
DEG .....	degrees	NI .....	nylon insert
FH .....	flat head	PPH .....	Phillips pan head
GA .....	gauge	PTH .....	Phillips truss head
HF .....	hex flange	PTO .....	power take off
HH .....	hex head	RH .....	right hand
HHF .....	hex head flange	SFH .....	slotted fillister head
HLH .....	hex lag head	SHH .....	slotted hex head
HJ .....	hex jam	SQH .....	square head
HOC .....	height-of-cut	SHWH .....	slotted hex washer head
HS .....	hex socket	SPH .....	slotted pan head
HSBH .....	hex socket button head	SRH .....	slotted round head
HSFH .....	hex socket flat head	STD .....	standard
HSH .....	hex socket head	TAP .....	self tapping
HWH .....	hex washer head	TTH .....	Torx truss head
HWHTF .....	hex washer head thread forming	WH .....	wing head



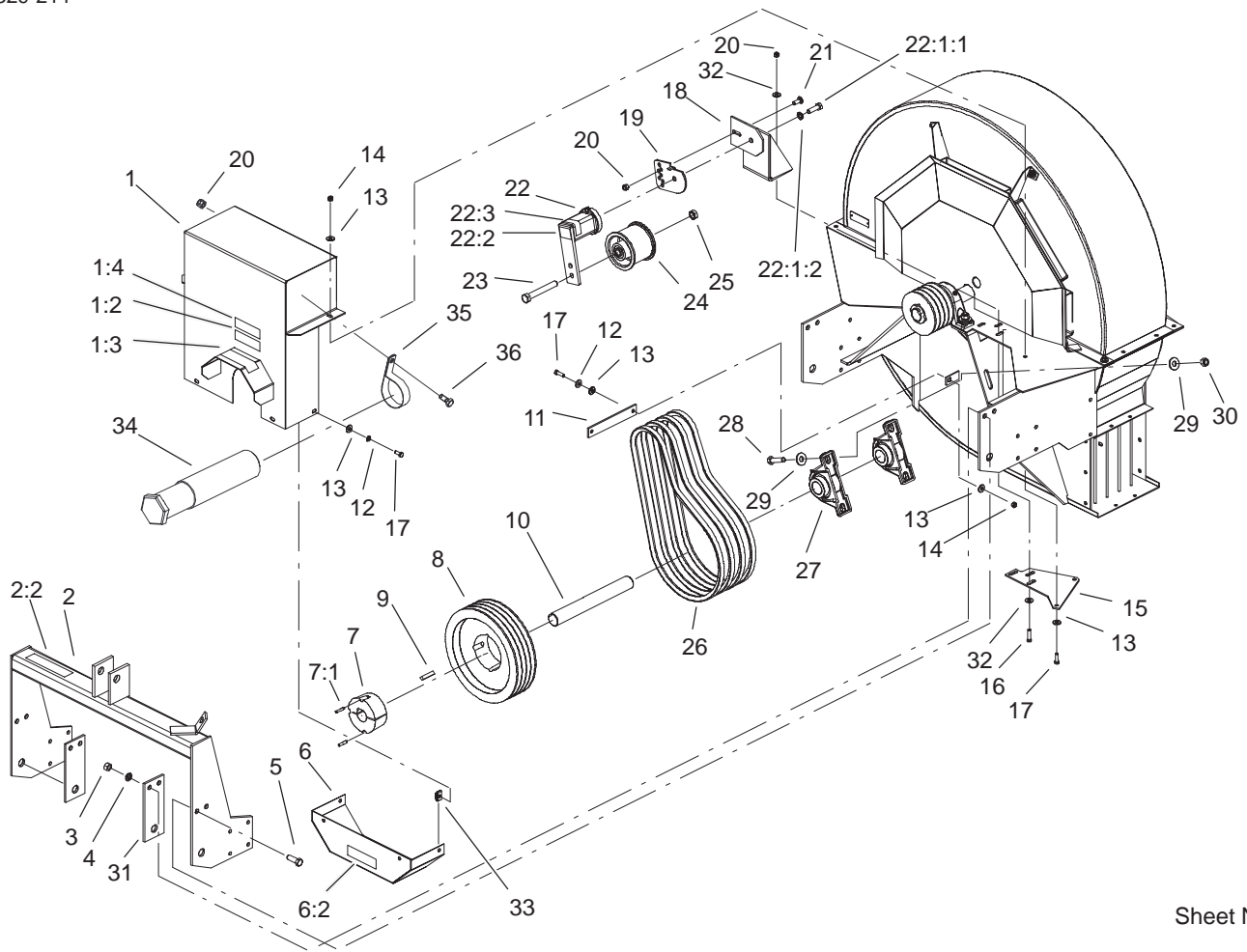

Sheet No.:3

## Drive Assembly

Ref. No.	Part No.	Qty.	Description
1	105-0685	1	Shield-Belt
1:2	93-7814	1	Decal-Danger
1:3	105-0628	1	Decal-Caution, U-Joint
1:4	105-0627	1	Decal-Caution
2	105-0714	1	Hitch ASM
2:2	105-0707	1	Decal-Ansi
3	3296-23	4	Nut-Lock, NI
4	3256-6	4	Washer-Flat
5	325-6	4	Screw-HH
6	105-0686	1	Shield-Lower
6:2	93-7814	1	Decal-Danger
7	LDB13400	1	Bushing-Taper, Lock
7:1	105-0683	2	Screw-Set
8	LDB12400	1	Pulley-Taper, Lock
9	41-004-5241	1	Key
10	LDB12100	1	Shaft-Input
11	LDB15700-01	1	Stabilizer-Shield
12	3253-4	4	Washer-Lock
13	3256-23	10	Washer-Flat
14	3296-29	3	Nut-Lock, NI
15	LDB14200-01	1	Support-Deck
16	323-8	3	Screw-HH
17	322-5	7	Screw-HH
18	LDB13200-01	1	Mount-Idler
19	105-4787-01	1	Stabilizer-Tensioner

Ref. No.	Part No.	Qty.	Description
20	3296-39	4	Nut-Lock, NI
21	3231-2	1	Screw-CARR
22	105-0667	1	Tensioner-Idler
22:1:1	33116-040	1	Screw-HH
22:1:2	3253-7	1	Washer-Lock
22:2	105-0668	1	Decal-Align
22:3	105-0669	1	Decal-Angle
23	3214-15	1	Screw-HH
24	105-4821	1	Idler-Pulley
25	3220-6	1	Nut-Jam
26	LDB13000	4	V-Belt
27	105-0621	2	Bearing-Block, Pillow
28	325-9	4	Screw-HH
29	3256-6	8	Washer-Flat
30	3296-23	4	Nut-Lock, NI
31	LDB10300-01	2	Stiffener-Hitch
32	3256-4	6	Washer-Flat
33	CSP11700	4	Nut-Thin, Tinnerman
34	74-0720	1	Tube-Manual
35	2412-133	2	R-Clamp
36	323-5	2	Screw-HH

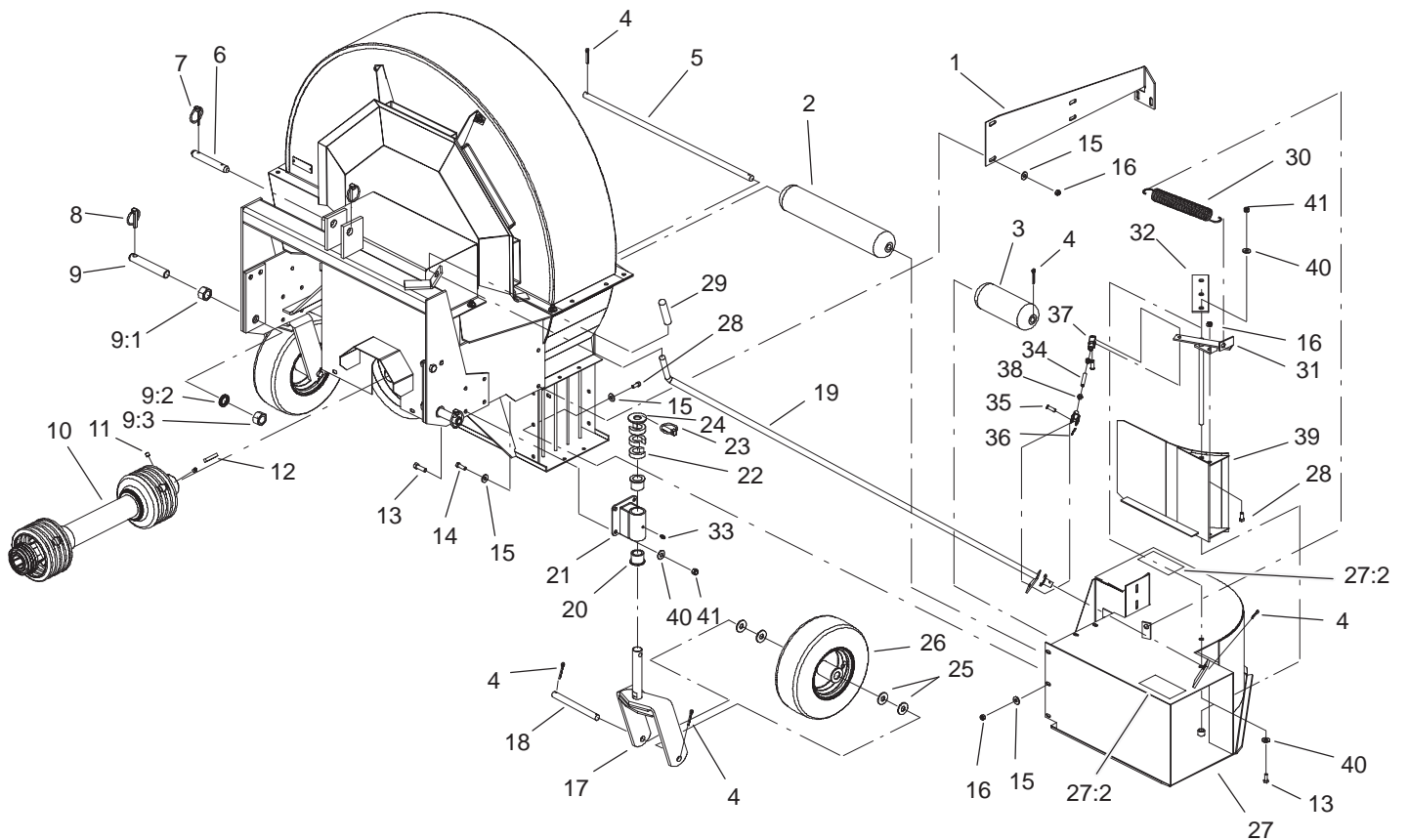

Sheet No.:4

## Chute and Roller Assembly

Ref. No.	Part No.	Qty.	Description
1	LDB11600-01	1	Brace-Discharge, Back
2	105-4823	1	Roller-Turf
3	LDB13300	1	Roller-Turf, Short
4	3272-22	7	Pin-Cotter
5	LDB13500	1	Axle-Roller
6	92-1233	1	Pin-Clevis
7	92-1298	2	Pin-Lynch
8	283-71	2	Pin-Lynch
9	01-252-0010	2	Lift Arm Pin Adjustment ASM
9:1	3219-18	1	Nut-Hex
9:2	3253-28	1	Washer-Lock/Sp
9:3	3219-8	1	Nut-Hex
10	105-4924	1	Driveshaft ASM
11	3247-2	2	Screw-Set, HS
12	41-004-5241	1	Key
13	323-6	10	Screw-HH
14	322-5	6	Screw-HH
15	3256-23	32	Washer-Flat
16	3296-29	17	Nut-Lock, NI
17	LDB10900-01	2	Caster-Fork
18	LDB11000	2	Axle-Wheel, Caster
19	LDB10700-01	1	Handle-Diverter
20	LDB11103	4	Bushing-Flange
21	LDB11100-01	2	Mount-Caster

Ref. No.	Part No.	Qty.	Description
22	LDB12600	6	Spacer-Slotted
23	283-71	2	Pin-Lynch
24	3256-62	2	Washer-Flat
25	3256-7	8	Washer-Flat
26	LDB12500	2	Castor Wheel ASM
27	105-0688	1	Discharge-Chute
27:2	105-0708	2	Decal-Danger
28	322-3	13	Screw-HH
29	PT503-00	1	Cover-Handle
30	105-4825	1	Spring-Ext
31	LDB10600-01	1	Pivot-Diverter
32	LDB10800-01	1	Plate-Top, Pin
33	302-58	2	Fitting-Grease
34	LDB14400	1	Rod-Threaded
35	283-1	2	Pin-Yoke
36	3272-10	2	Pin-Cotter
37	282-2	2	Yoke
38	3220-2	2	Nut
39	LDB11800-01	1	Gate ASM
40	3256-24	12	Washer-Flat
41	3296-39	10	Nut-Lock, NI





