



# Spiker Kit

## Greensmaster® 3000 Series Attachment

Model No. 04494—Serial No. 220000001 and Up

Form No. 3329–232 Rev A

### Operator's Manual

**Important** Read this *Operator's Manual* thoroughly before operating the Spiker Kit. Failure to do so may result in damage to the spiker.

## Setup Instructions

### Mounting the Pull Arm Bumpers (Greensmaster 3050, 3100, 3150, and 3200)

1. Using the dimensions shown in Figure 1, locate, mark, and drill two 0.221 in. diameter holes in the underside of each pull frame cross tube.

**Note:** Holes may already be present in the cross tubes.

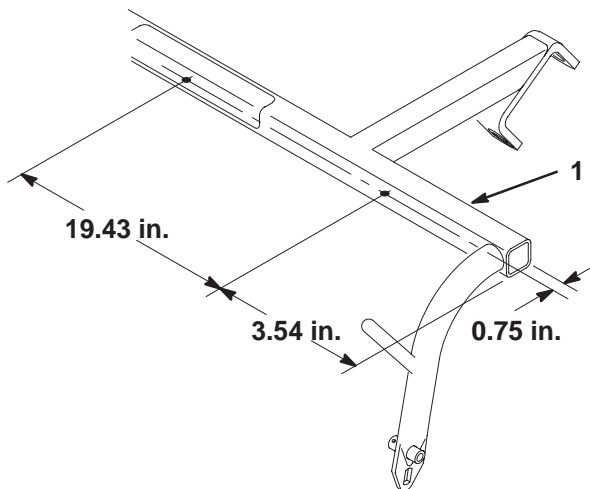
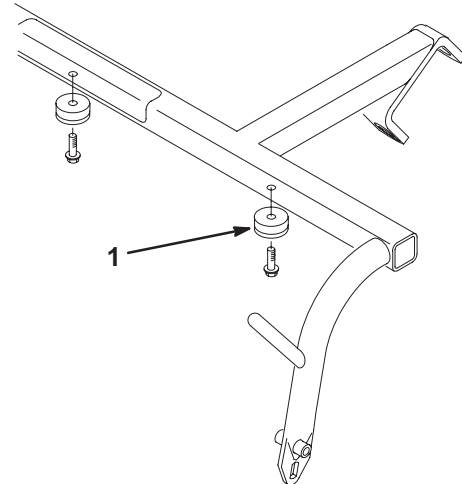

**Figure 1**

Greensmaster 3050, 3100, and 3150 Shown

1. Pull frame cross tube

2. Mount the 2 recessed bumpers to the underside of each pull frame cross tube with 2 washer head self tapping screws (1/4 x 3/4 in.) (Fig. 2).



**Figure 2**

Greensmaster 3050, 3100, and 3150 Shown

1. Recessed bumper

### Adjusting the Rear Roller Scrapers

**Note:** The rear roller scraper is adjusted at the factory but can be adjusted to meet turf conditions.

1. Loosen the locknuts securing the scraper to the frame.
2. Adjust the scraper until there is 0.03–0.06 in. clearance between the edge of the scraper and the roller.
3. Tighten the locknuts securing the scraper.

## Mounting the Spikers

1. Park the machine on a level surface, lower the lift arms, stop the engine, and set the parking brake.

**Note:** If the carrier frames are equipped with single point pull frames, the pull frame and attaching ball joint must be removed (Fig. 3).

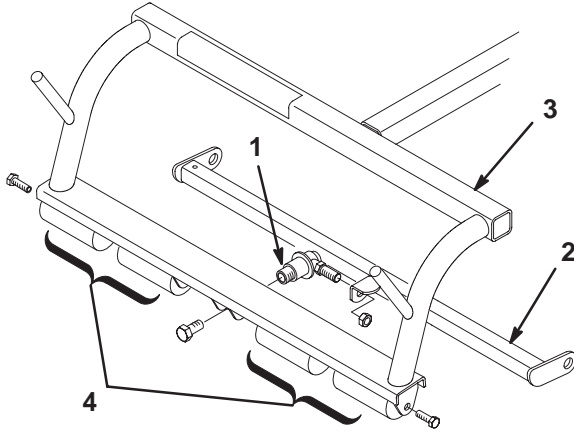
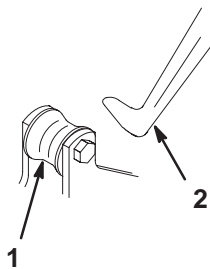

**Figure 3**

Greensmaster 3200 Only

- |                |                  |
|----------------|------------------|
| 1. Ball socket | 3. Carrier frame |
| 2. Pull frame  | 4. Roller sets   |

2. Slide the spiker unit under the traction unit pull frame while hooking the lift roller onto the lift arm (Fig. 4).



**Figure 4**

- |                |             |
|----------------|-------------|
| 1. Lift roller | 2. Lift arm |
|----------------|-------------|

3. Mount the pull link assemblies to the **Greensmaster 3200 and 3250** pull arms as follows:

- A. Remove the screws securing the outside ends of each anti-scalp roller shaft to each end of the carrier frame (outside end of shafts only) (Fig. 3).
- B. Assemble a jam nut and ball joint receiver onto each pull link assembly as shown in Figures 5 and 6.
- C. Mount a pull link assembly to each end of the carrier frame with a spacer, washer, and screw (Fig. 5 and 6). Make sure that the nylon bushing is in the pull link.

- D. Install a ball stud and lock washer to each end of the spiker (Fig. 5 and 6).
- E. Adjust the pull links all of the way forward and tighten the jam nut.
- F. Slide the sleeve back on each ball joint receiver and hook them onto the ball studs (Fig. 5 and 6).

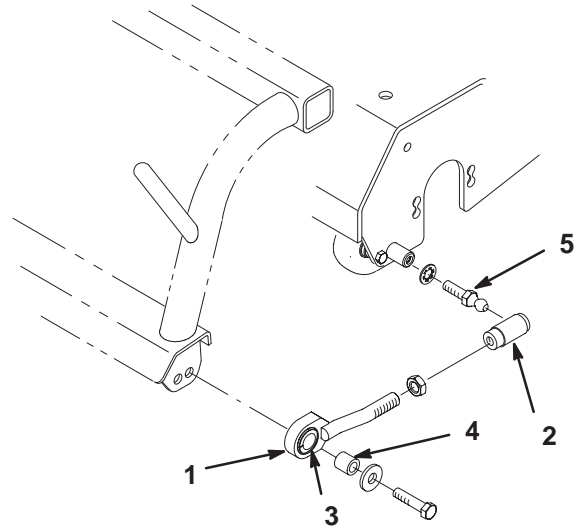

**Figure 5**

Greensmaster 3200 Shown

- |                        |                               |
|------------------------|-------------------------------|
| 1. Pull link assembly  | 4. Spacer                     |
| 2. Ball joint receiver | 5. Ball stud (large diameter) |
| 3. Nylon bushing       |                               |

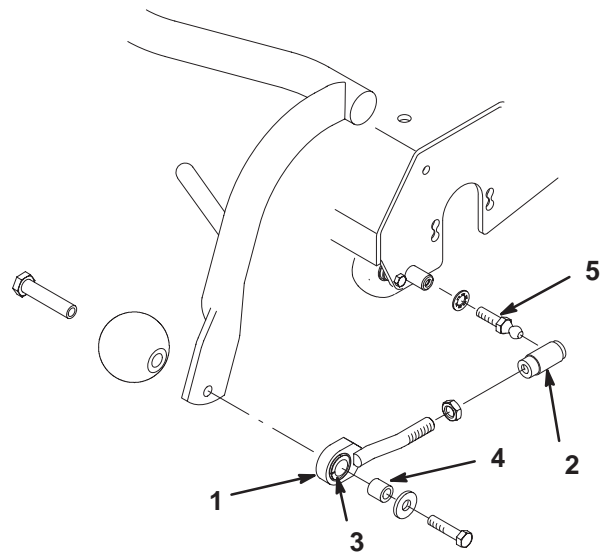
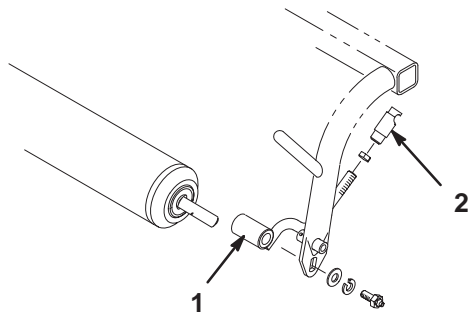

**Figure 6**

Greensmaster 3250 Shown

- |                        |                               |
|------------------------|-------------------------------|
| 1. Pull link assembly  | 4. Spacer                     |
| 2. Ball joint receiver | 5. Ball stud (large diameter) |
| 3. Nylon bushing       |                               |

4. Mount the pull link assemblies to the **Greensmaster 3050, 3100, and 3150** pull arms as follows:
  - A. Remove the fasteners securing the roller shaft and pull arms to each end of the carrier frame (Fig. 7).
  - B. Install the roller and new pull arm assemblies to the carrier frame with the fasteners that were previously removed (Fig. 7). Position the pull arms so that they bend outward.



**Figure 7**

1. Pull link assembly
2. Ball joint receiver

- C. Assemble a jam nut and ball joint receiver onto each pull link assembly as shown in Figure 7.
- D. Install a ball stud and lock washer to each end of the spiker (Fig. 5 and 6).
- E. Adjust the pull links all of the way forward and tighten the jam nut.
- F. Slide the sleeve back on each ball joint receiver and hook them onto the ball studs (Fig. 5 and 6).

**Note:** To avoid spiker interference with the traction pedal linkage, it may be necessary to lower the spikers when the reels are in the raised (transport) position; refer to Adjusting the Lift Cylinders in the Maintenance section of the traction unit *Operator's Manual*.

**Note:** When mounting the Spiker Kit in the right front position on the Greensmaster 3200 and 3250 traction units, remove the counter weight from the left end of the unit and mount it on the right end. The motor is to be connected to the left end.

5. Mount the front reel motors into the storage positions as follows:
  - A. Loosen the mounting screws for the reel motor to each spiker. Leave approximately 1/2 in. of threads exposed on each mounting screw (Fig. 8).

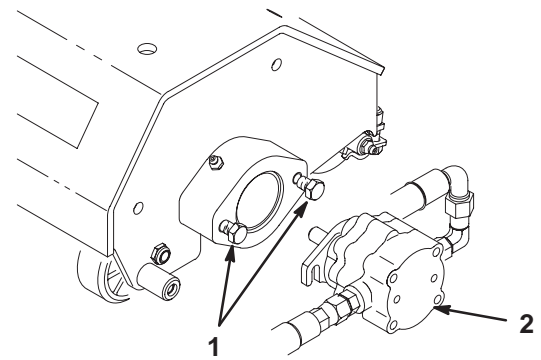

**Figure 8**

1. Screws and washers
2. Reel motor

- B. Install the motor by rotating the motor clockwise so the motor flanges clear the screws. Rotate the motor counterclockwise until the flanges encircle the screws. Tighten the screws.
6. Store the rear reel motor on the Greensmaster 3150, 3200, and 3250 the same as the front reel motors.
7. Store the rear reel motor on the Greensmaster 3100 and Greensmaster 3050 as follows:
  - A. Using the dimensions shown in Figure 9, locate and scribe a line on the appropriate frame member.

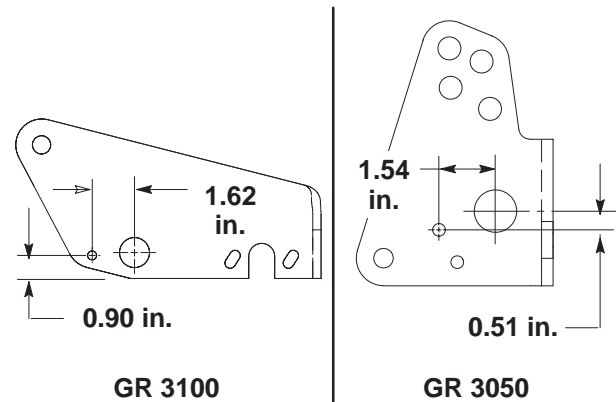
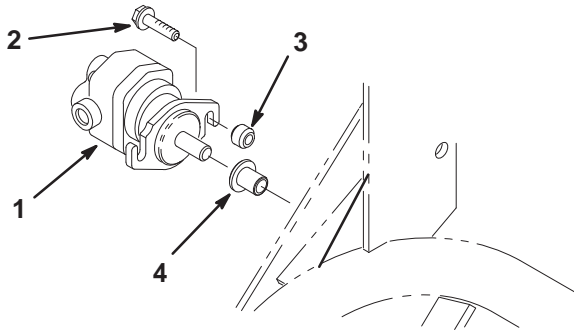

**Figure 9**

- B. Insert the splined shaft of the reel motor into the storage tube on the frame (Fig. 10).
- C. Using the reel motor flange as a template and positioning it as shown in Figure 10, locate, mark, and drill a 0.344 in. diameter hole on the scribed line.

**Note:** The hole in the frame may already be present.

D. Position the spacer between the reel motor flange and the frame while aligning the holes. Secure the reel motor and spacer to the frame with a self tapping screw.



**Figure 10**

- |                       |                 |
|-----------------------|-----------------|
| 1. Reel motor         | 3. Spacer       |
| 2. Self tapping screw | 4. Storage tube |

8. Mount the counter weight to the right side of the rear spiker with 2 capscrews and washers.

### Installing the Rear Weight

The Greensmaster Traction Units comply with ANSI B71.4-1999 and EN836:1997 Standards when 43 lbs. of calcium chloride ballast is added to the rear wheel and also equipped with rear weight. Order the appropriate weight kit (see below) from your local Authorized Toro Distributor.

Traction Unit	Weight Kit Part No.
Greensmaster 3050, 3100, or 3200 2-Wheel Drive	99-1640
Greensmaster 3100, 3150, 3200, or 3250 3-Wheel Drive or with 3-Wheel Drive Kit	99-1645
Greensmaster 3100 (Model No. 04356), 3150 (Model No. 04357), and 3250-D (Model No. 04383) (2-Wheel Drive)	100-6442
Greensmaster 3150, 3200 or 3250 with ROPS only and 2-Wheel Drive	100-6442

## Operation

### Training Period

Before spiking greens with the spiker attachments, find a clear area and practice starting, stopping, raising, lowering, and spiking with the spiker reels. This training period will be beneficial to the operator in gaining confidence in the performance of the spiker reels.

### Operating Tips

Maintain a straight line when spiking. Do not turn when the spiking units are in the ground.

When the edge of the green is reached, raise the spiker reels before turning or stopping. The spiker reels must be raised **completely** before making turns. Never use the grass catcher with the spiking reels. Survey the green to determine if there are any obstacles that will be damaged or will result in damage to the spiker reels such as sprinkler heads and protruding objects.

## Maintenance

### Lubrication

There are 4 grease fittings on each spiker unit, which must be lubricated after every 15 hours of operation. Lubricate using a #2 multipurpose lithium base grease. For best results, use a hand operated grease gun.

1. Wipe each grease fitting with a clean rag.
2. Apply grease to the spiker shaft bearings and rear roller bearings (Fig. 11) until pressure is felt.

**Important** Do not apply too much pressure or grease seals will be permanently damaged.

3. Wipe excess grease away.

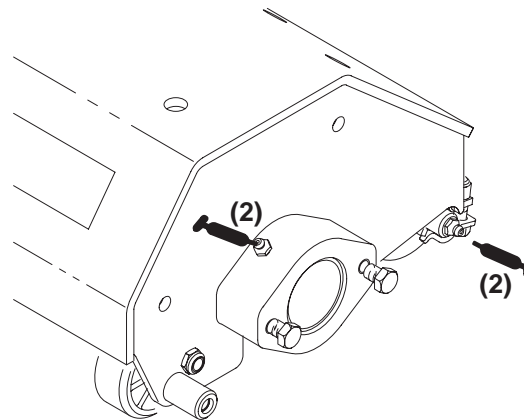

**Figure 11**