



GeoLink® Precision Spray System Finishing Kit

Serial number 31600000 and After Multi Pro® 5800 Turf Sprayer
Model No. 41743—Serial No. 41540000 and Up

Installation Instructions

Note: Install the Finishing Kit with GeoLink Model 41712 or 41713.

Introduction

The GeoLink spray system kit is an attachment for a Toro Multi Pro turf spray application vehicle and is intended to be used by professional, hired operators in commercial applications. It is designed primarily for spraying on well-maintained lawns in parks, golf courses, sports fields, and on commercial grounds. Using this product for purposes other than its intended use could prove dangerous to you and bystanders.

Read this information carefully to learn how to operate and maintain your product properly and to avoid injury and product damage. You are responsible for operating the product properly and safely.

Visit www.Toro.com for product safety and operation training materials, accessory information, help finding a dealer, or to register your product.

Whenever you need service, genuine Toro parts, or additional information, contact an Authorized Service Dealer or Toro Customer Service and have the model and serial numbers of your product ready. [Figure 1](#) identifies the location of the model and serial numbers on the product. Write the numbers in the space provided.

Important: With your mobile device, you can scan the QR code (if equipped) on the serial number plate to access warranty, parts, and other product information.

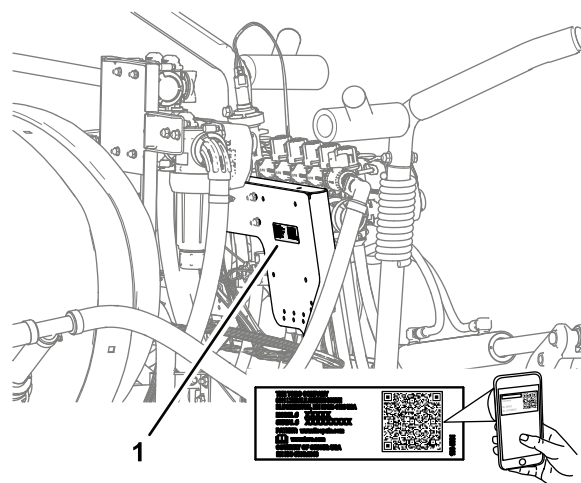

g281138

Figure 1

1. Model and serial number location

<p>Model No. _____</p> <p>Serial No. _____</p>
--

This manual identifies potential hazards and has safety messages identified by the safety-alert symbol ([Figure 2](#)), which signals a hazard that may cause serious injury or death if you do not follow the recommended precautions.



g000502

Figure 2

1. Safety-alert symbol

This manual uses 2 words to highlight information. **Important** calls attention to special mechanical information and **Note** emphasizes general information worthy of special attention.



Contents

Introduction	1
Safety	2
Safety and Instructional Decals	3
Setup	4
1 Preparing the Machine	6
2 Removing the Undercarriage Shroud	7
3 Removing the Engine Control Module and Mounting Bracket	8
4 Disconnecting the Pressure Sense Tube for the Dash Gauge	8
5 Removing the Rear Wire Harness for the Machine	9
6 Removing the Rate Control Switch	13
7 Removing the Boom-Section Valves	14
8 Relocating the Pressure Transducer	21
9 Installing the Valve Mount, Rate/Section Controller, and Section Valves	22
10 Removing the Hoses for the 3-Section System	25
11 Installing the Hoses	27
12 Assembling the Rear Wiring Harness to the Machine	34
13 Installing the Engine Control Module and Mounting Bracket	38
14 Installing the Undercarriage Shroud	38
15 Connecting the Rear Wire Harness	39
16 Connecting the Pressure Sense Tube for the Dash Gauge	47
17 Installing the Navigation Receiver	47
18 Installing the Modem Antennas to the Machine	48
19 Installing the Display	49
20 Installing the Wire Harnesses for the Navigation Components	51
21 Assembling the Modem Power Harness to the Machine	55
22 Assembling the Modem Data Harness to the Machine	58
23 Installing the CL-55 Modem	59
24 Routing the ISO-CAN Bus Harness	61
25 Removing the CAN Bus Resistor	63
26 Installing the Adapter Harness and Terminating Resistor	65
27 Completing the Installation of the GeoLink Spray System-Finishing Kit	65
28 Powering the GeoLink Components	68
29 Completing the Software Setup	68

Safety

⚠ WARNING

Chemical substances used in the spray system may be hazardous and toxic to you, bystanders, animals, plants, soil, or other property.

- Carefully read and follow the chemical warning labels and safety data sheet (SDS) for all chemicals used and protect yourself according to the chemical manufacturer's recommendations. For example, use appropriate personal protective equipment (PPE), including face and eye protection, gloves, or other equipment to guard against personal contact with a chemical.
- There may be more than 1 chemical used and information on each chemical; assess each chemical.
- Refuse to operate or work on the sprayer if this information is not available.
- Before working on a spray system, ensure that the system has been triple rinsed and neutralized according to the recommendations of the chemical manufacturer(s) and that all the valves are cycled 3 times.
- Verify that there is an adequate supply of clean water and soap nearby, and immediately wash off any chemicals that contact you.

Safety and Instructional Decals



Safety decals and instructions are easily visible to the operator and are located near any area of potential danger. Replace any decal that is damaged or missing.

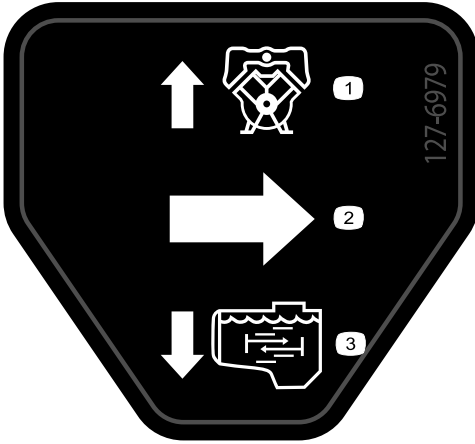

127-6979

decal127-6979

- 1. Bypass-return flow
- 2. Flow
- 3. Agitation flow

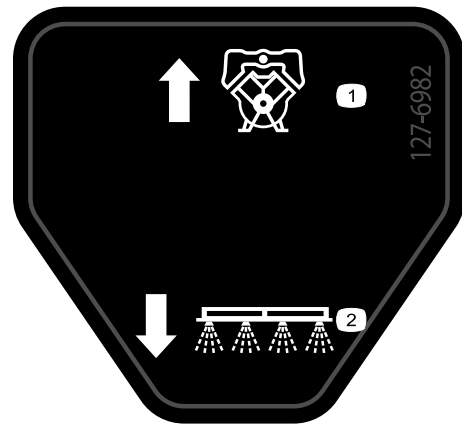

127-6982

decal127-6982

- 1. Bypass-return flow
- 2. Boom spray



127-6976

decal127-6976

- 1. Decrease
- 2. Increase

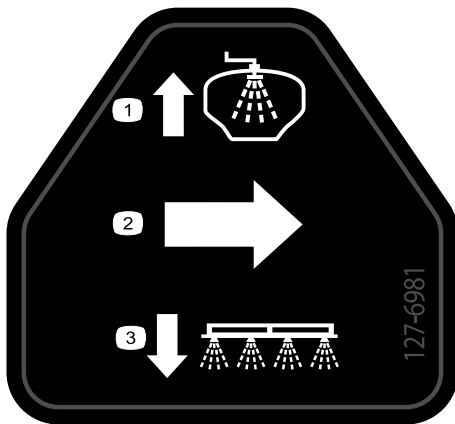

127-6981

decal127-6981

- 1. Bypass-return flow
- 2. Flow
- 3. Boom spray

Installation

Loose Parts

Use the chart below to verify that all parts have been shipped.

Procedure	Description	Qty.	Use
1	No parts required	–	Prepare the machine.
2	No parts required	–	Remove the undercarriage shroud.
3	No parts required	–	Remove the engine control module and mounting bracket.
4	No parts required	–	Disconnecting the pressure sense tube for the dash gauge.
5	No parts required	–	Remove the rear wire harness for the machine.
6	Cable tie Switch plug	1 1	Remove the rate control switch.
7	Fitting cap Cap (quick coupler) Retainer	1 3 3	Remove the boom-section valves.
8	Barbed-flange fitting (1 inch) Hose (1 x 7-1/4 inches) Hose clamp Pressure transducer Manifold Hose (1 x 8-1/2 inches) R-clamp	1 1 3 1 1 1 1	Relocate the pressure transducer.
9	Valve mount and valve assembly Rate/Section controller Magnet Bolt (#8) Washer (8) Locknut (#8) Flange-head bolts (5/16 x 3/4 inch) Flange locknuts (5/16 inch) Hose clamp Flange head bolt (1/4 x 3/4 inch) Flange locknut (1/4 inch)	1 1 4 4 4 4 8 8 1 2 2	Install the valve mount, rate/section controller, and valves.
10	No parts required	–	Remove the hoses.
11	Supply hose 279 cm (110 inches) Supply hose 234 cm (92 inches) Supply hose 188 cm (74 inches) Supply hose 81 cm (32 inches) R-clamp Double R-clamp Single R-clamp	2 2 4 2 2 2 2	Install the hoses.
12	Rear wire harness Cable tie	1 3	Assemble the rear wiring harness to the machine.

Procedure	Description	Qty.	Use
13	No parts required	–	Install the engine control module and mounting bracket.
14	No parts required	–	Install the undercarriage shroud.
15	Cable tie	3	Connect the rear wire harness.
16	No parts required	–	Connect the pressure sense tube for the dash gauge.
17	Navigation receiver Receiver mount Bolts (M5) Lock washer U-bolt Flange locknut (3/8 inch)	1 1 4 4 4 4	Install the navigation receiver.
18	Antenna mount Rivet Magnet Modem antenna High gain antenna Cable ties	1 2 2 1 1 7	Install the modem antennas to the machine.
19	Display Ball mount Monitor arm Stiffener bracket Hex-head bolt (1/4-20 x 1-1/2 inches) Washer (1/4 inch) Locknut (1/4 inch)	1 1 1 1 8 4 8	Install the display.
20	Harness adapter Data and electrical harness Cable tie	1 1 8	Install the wire harnesses for the navigation components.
21	Modem power harness—1850 mm (72-7/8 inches)—GeoLink precision spray system kit (Model 41712 or Model 41713) Cable ties—GeoLink precision spray system kit (Model 41712 or Model 41713)	1 5	Install the modem power harness.
22	Modem data harness—300 cm (118 inches) Cable ties	1 8	Route the modem data harness.
23	CL-55 modem Modem bracket Bolt (#10 x 1-3/4 inch) Spacer Locknut (#10)	1 1 2 2 2	Install the CL-55 modem.
24	ISO-CAN bus harness—302 cm (119 inches) Cable ties	1 12	Route the ISO-CAN bus harness.
25	No parts required	–	Remove the CAN bus resistor.

Procedure	Description	Qty.	Use
26	Adapter harness—13 cm (5 inches) Cable tie	1 1	Install the adapter harness and terminating resistor.
27	No parts required	–	Complete the installation of the GeoLink spray system-finishing kit.
28	No parts required	–	Power the GeoLink components.
29	No parts required	–	Complete the software setup.

1

Preparing the Machine

No Parts Required

Procedure

Refer to the *Operator's Manual* for your machine.

1. Park the machine on a level surface and engage the parking brake.
2. Extend the left and right boom sections to the horizontal position.
3. Shut off the engine, remove the key, and disconnect the battery.
4. Clean the sprayer.

Important: You must completely empty the spray tank before installing the GeoLink Spray System Finishing Kit.

2

Removing the Undercarriage Shroud

No Parts Required

Procedure

- Remove and retain the following hardware that secures the rear of the undercarriage shroud to the chassis of the machine:
 - 2016 machines**—7 flange-head bolts (5/16 x 7/8 inch) and 7 washers (5/16 inch)
 - 2017 and later machines**—5 flange-head bolts (5/16 x 7/8 inch) and 5 washers (5/16 inch)

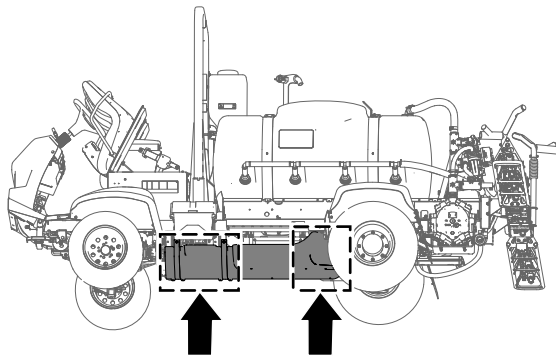

g189584

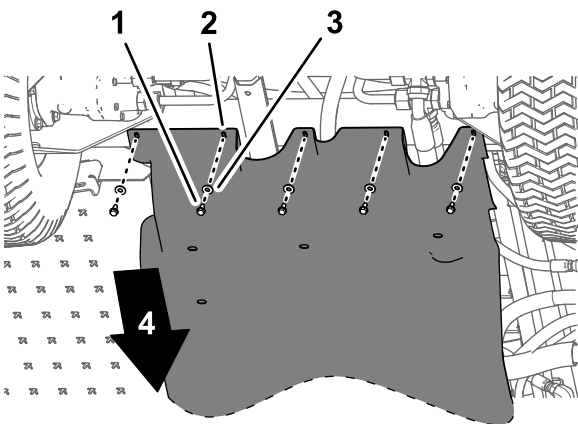

g189585

Figure 3

2017 machine shown; 2016 machines are similar

- Flange-head bolts (5/16 x 7/8 inch)
- Undercarriage shroud
- Washers (5/16 inch)
- Front of the machine

the support straps of the undercarriage shroud to the engine-mount brackets of the machine.

Note: Do not remove the bolts from the machine.

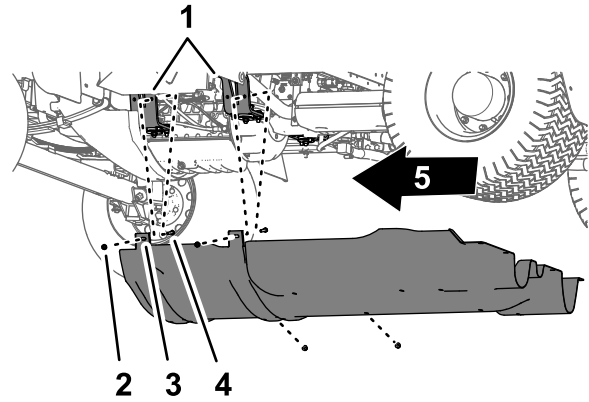

g189583

Figure 4

- Engine mounts
- Bolt—shown for clarity; do not remove
- Undercarriage shroud
- Flange locknuts (5/16 inch)
- Front of the machine

- Lift the support straps over the bolts that secure the undercarriage shroud to the engine-mount brackets.
- Remove the undercarriage shroud from the machine.

- Remove and retain the 4 flange locknuts (5/16 inch) from the bolts and carriage bolt that secure

3

Removing the Engine Control Module and Mounting Bracket

No Parts Required

Procedure

1. Remove and retain the 3 flange head bolts and 1 flange nut that secure the mounting bracket for the engine control module to the support bracket of the engine and accessory case of the engine.

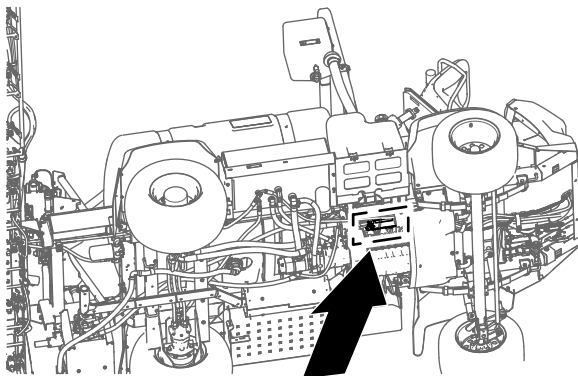

g189642

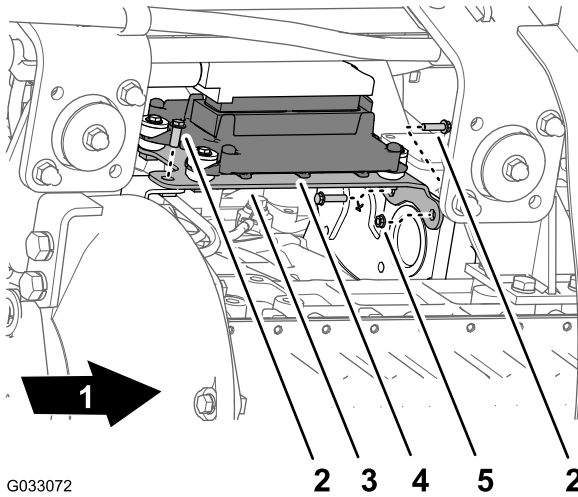

G033072

g033072

Figure 5

1. Front of the machine
2. Flange head bolt
3. Mounting bracket
4. Engine control module
5. Flange nut

2. Move the engine control module and mounting bracket down and rearward to provide access to the connectors of the front and rear wiring harnesses for the machine.

Note: Do not remove or disconnect the engine control module from the engine.

4

Disconnecting the Pressure Sense Tube for the Dash Gauge

No Parts Required

Procedure

1. Press in the collar for the tube coupler at the 90° elbow at the right boom-section valve.

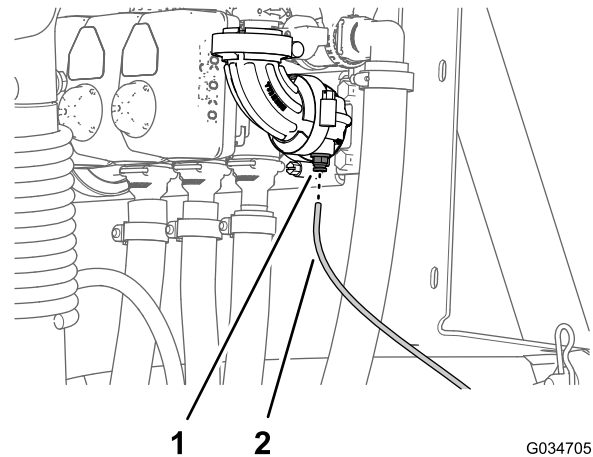

G034705

g034705

Figure 6

1. Tube coupler (90° elbow at the right boom-section valve)
 2. Pressure sense tube
-
2. Pull the pressure sense tube for the dash pressure gauge out of the tube coupler.

5

Removing the Rear Wire Harness for the Machine

No Parts Required

Disconnecting the Front and Rear Wire Harnesses

Note: Use a machine hoist when disconnecting the front and rear wire harnesses.

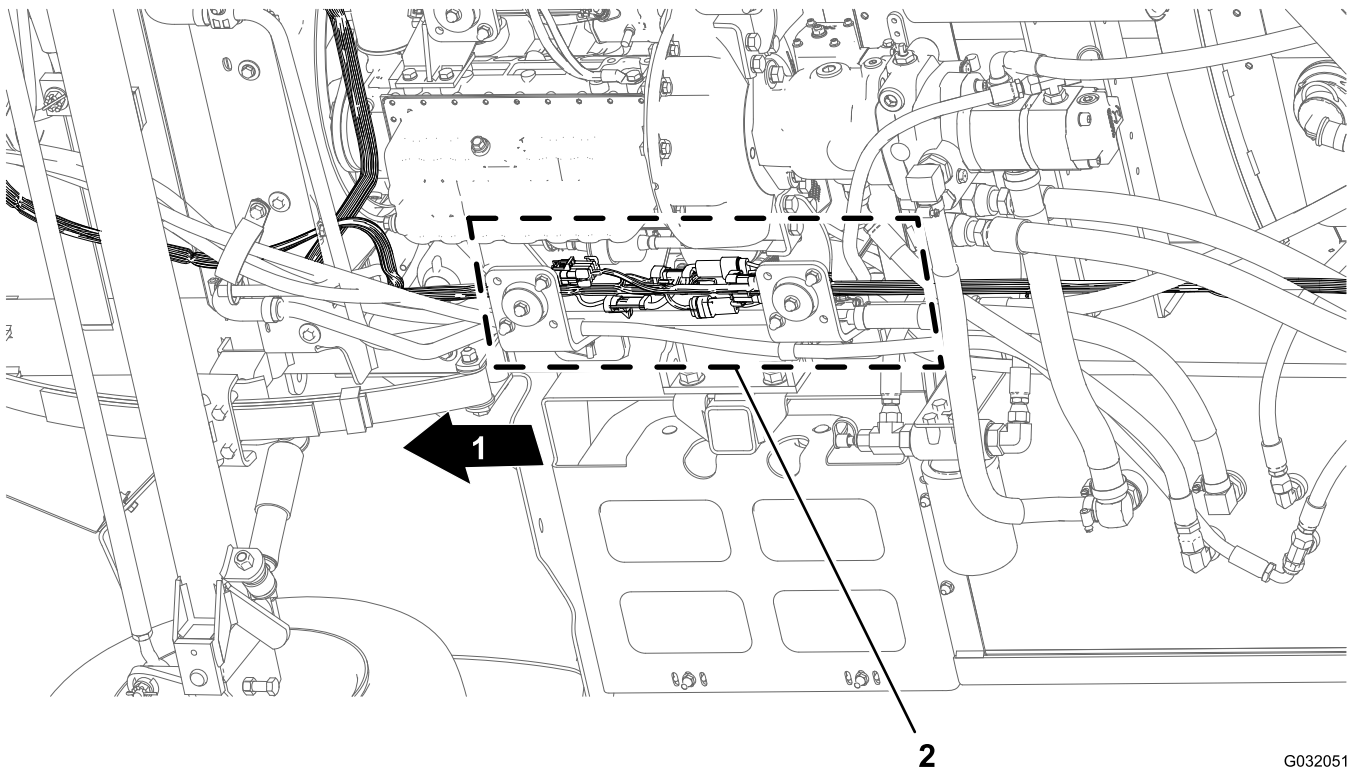

G032051
g032051

Figure 7

1. Front of the machine
2. Connector interfaces (front and rear wire harnesses)

1. From under the machine along the right frame tube, locate the electrical connectors for the front and rear wire harnesses of the machine (Figure 7).
2. Disconnect the 6 pairs of connectors between the front and rear wire harnesses as shown in Figure 8 through Figure 13.

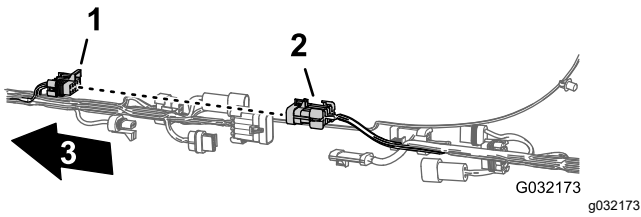

Figure 8

1. 10-pin connector—sprayer-harness interconnect (rear harness)
2. 10-socket connector—sprayer-harness interconnect (front harness)
3. Front of the machine

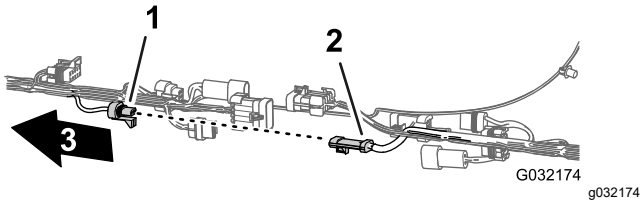

Figure 9

1. 3-pin connector—flow meter (rear harness)
2. 3-socket connector—flow meter (front harness)
3. Front of the machine

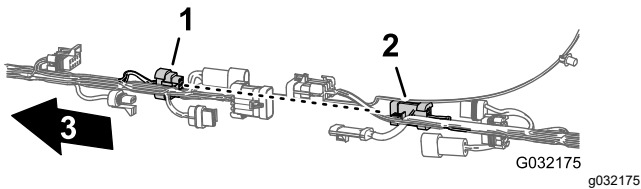

Figure 10

1. 8-pin connector—sprayer-harness interconnect (rear harness)
2. 8-socket connector—sprayer-harness interconnect (front harness)
3. Front of the machine

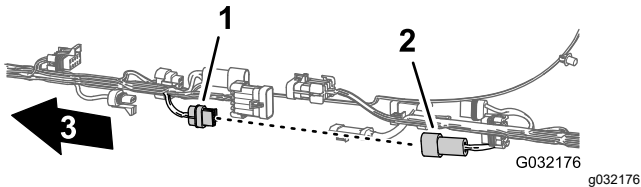

Figure 11

1. 2-pin connector—rinse pump (rear harness)
2. 2-socket connector—rinse pump (front harness)
3. Front of the machine

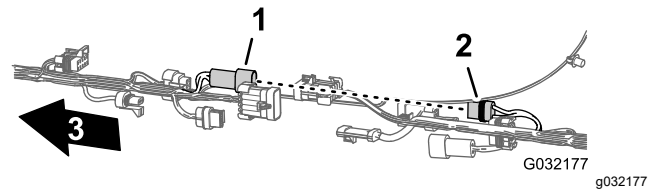

Figure 12

1. 2-pin connector—hose reel (front harness)
2. 2-socket connector—hose reel (rear harness)
3. Front of the machine

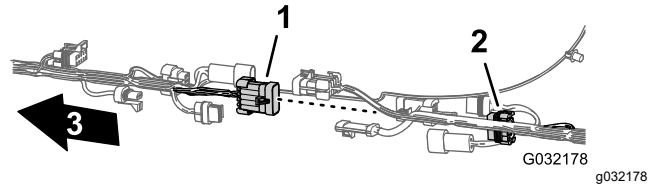

Figure 13

1. 10-pin connector—sprayer-harness interconnect (front harness)
2. 10-socket connector—sprayer-harness interconnect (rear harness)
3. Front of the machine

3. Remove the 3 push-in fasteners that secure the rear wire harness to the holes in the right frame tube of the machine (Figure 14).

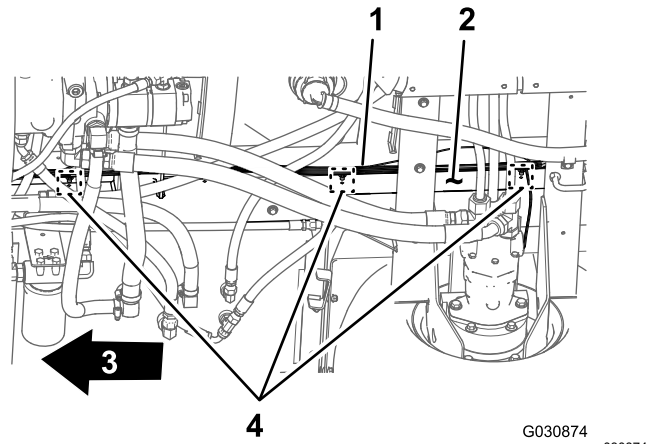

Figure 14

1. Rear wire harness
2. Right frame tube
3. Front of the machine
4. Push-in fasteners

Disconnecting the Connectors for the Components

- At back of the machine (between the right frame tube and the right fender), disconnect the 3-pin connector of the speed-sensor harness at the right hydraulic traction motor from the 3-socket connector of the rear, main harness.

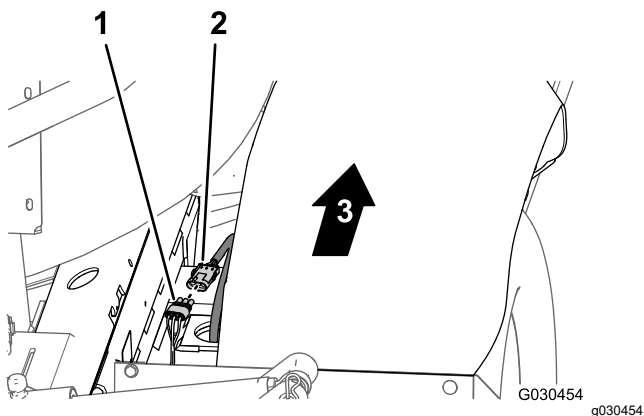

Figure 15

- 3-socket connector (rear, main harness)
- 3-pin connector (hydraulic-motor harness)
- Front of the machine

- At the back of the manifold mount, disconnect the 3-socket connector from the agitation valve and the 3-socket connectors from the 3 boom-section valves.

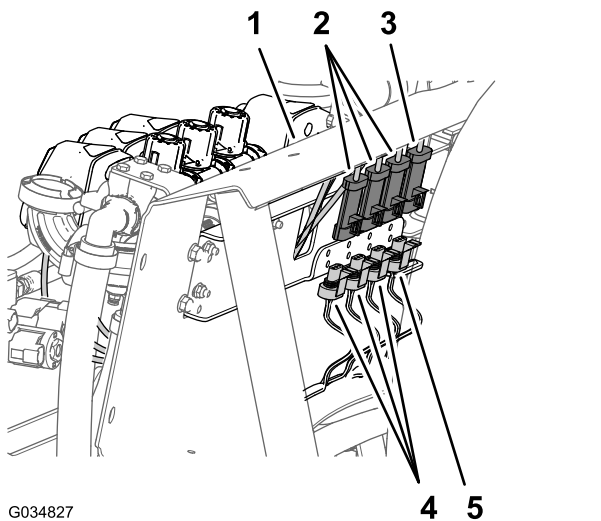

Figure 16

- Manifold mount
- 3-socket connectors (boom-section valve harnesses)
- 3-socket connector (agitation valve harness)
- 3-pin connectors (machine wire harness—rear)
- 3-pin connector (machine wire harness—rear)

- Remove the push-in fasteners that secure the rear wire harness to the holes at the forward side and lower plate of the manifold mount.

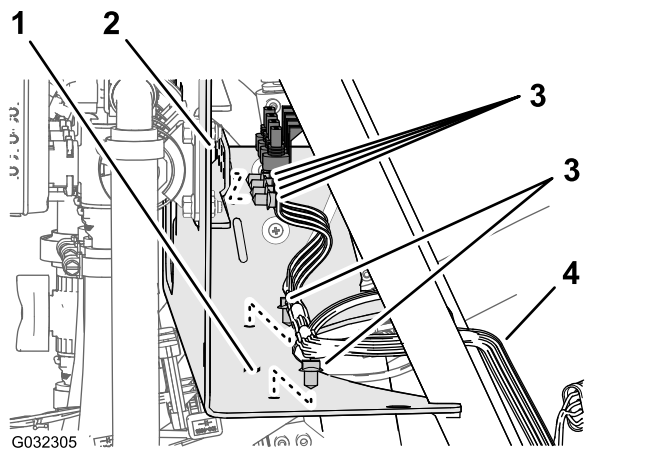

Figure 17

- Manifold mount (lower side)
- Manifold mount (forward side)
- Push-in fasteners
- Rear wire harness

- Disconnect the 3-socket connector of the rear-wire-harness from the 3-pin connector of the pressure transducer.

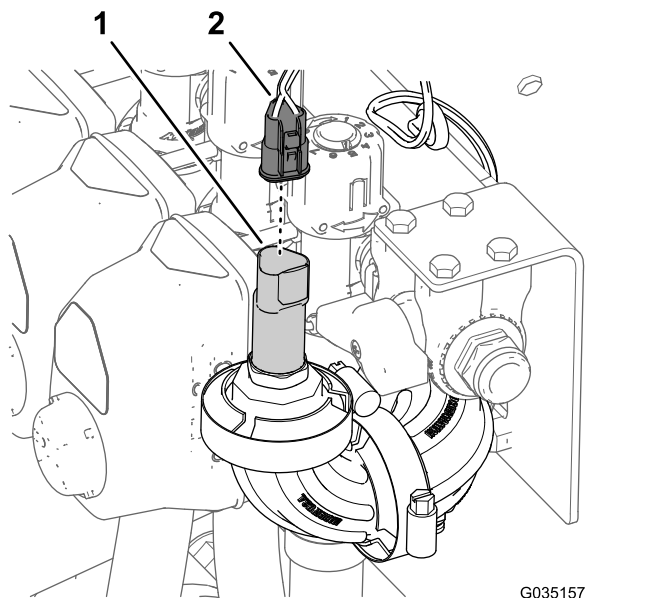

Figure 18

- 3-pin connector (pressure transducer)
- 3-socket connector (rear-wire-harness)

- At the back of the machine, disconnect the following 2-socket connectors for the lift-cylinder manifold as follows:

- Right—up solenoid
- Left—up solenoid

- Enable solenoid
- Right—down solenoid
- Left—down solenoid

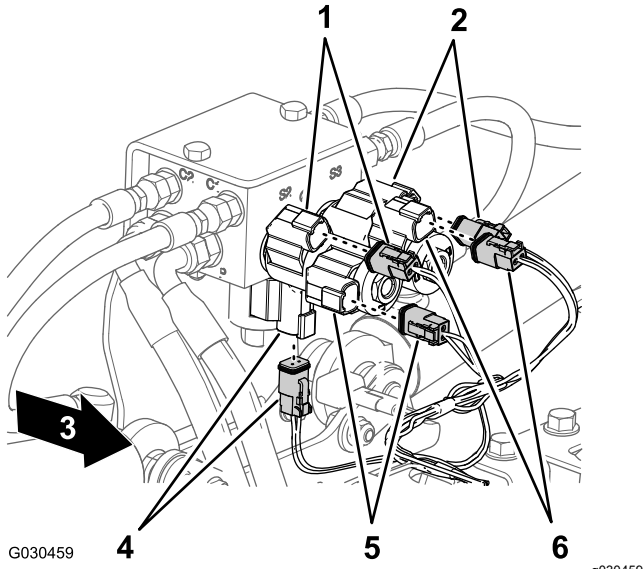

Figure 19

- | | |
|---|---|
| 1. Right—up (solenoid and main-harness connector) | 4. Enable (solenoid and main-harness connector) |
| 2. Left—up (solenoid and main-harness connector) | 5. Right—down (solenoid and main-harness connector) |
| 3. Front of the machine | 6. Left—down (solenoid and main-harness connector) |

6. At the back of the machine, inboard of the spray pump, disconnect the 2-socket connector of the rear, main harness from the 2-pin connector of the relay for the pump.

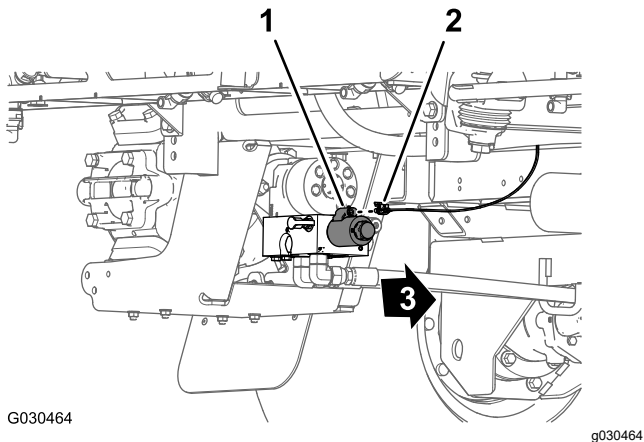

Figure 20

- | | |
|--|-------------------------|
| 1. 2-pin connector (pump relay) | 3. Front of the machine |
| 2. 2-socket connector (rear, main harness) | |

7. Remove the push-in fastener that secures the rear wire harness to the holes in the rear cross tube (rearward of the hydraulic-traction motors).

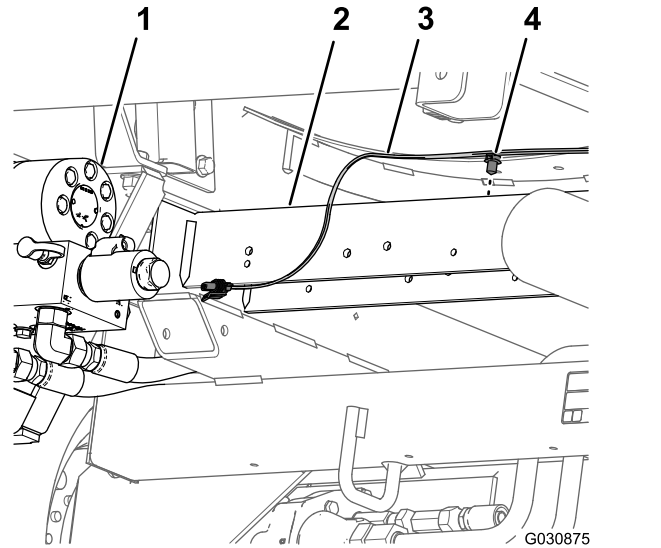

Figure 21

- | | |
|--------------------|----------------------|
| 1. Spray pump | 3. Rear wire harness |
| 2. Rear cross tube | 4. Push-in fastener |

8. Remove the pressure sense tube for the dash gauge from the rear wire harness from the machine.

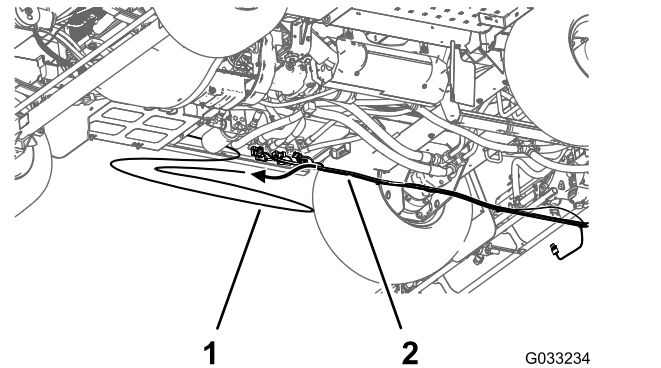

Figure 22

- | | |
|-------------------------------------|----------------------|
| 1. Pressure sense tube (dash gauge) | 2. Rear wire harness |
|-------------------------------------|----------------------|

9. Remove the rear wire harness from the machine.

Note: You no longer need the rear main harness that you removed from the machine.

6

Removing the Rate Control Switch

Parts needed for this procedure:

1	Cable tie
1	Switch plug

Procedure

1. From under the dash panel of the machine, squeeze the lock tabs of the rate-control switch together and push up the rate-control switch out of the dash panel.

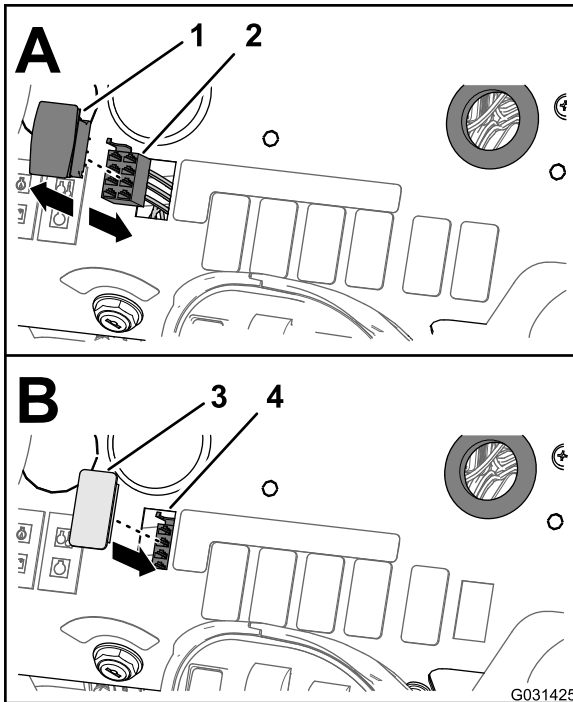

Figure 23

1. Rate-control switch
2. 8-socket connector(front harness)
3. Switch plug
4. Opening (dash panel)

2. Disconnect the 8-socket connector of the front harness of the machine (labeled **Rate Switch**) from the 8-pin connector of the switch.

Note: You no longer need the rate switch that you removed from the machine.

3. Route the branch of the front harness for the rate switch through the opening in the dash

and secure the wiring branch against the front harness with a cable tie.

4. Insert the switch plug into the dash panel until the plug snaps into the panel securely.

7

Removing the Boom-Section Valves

Parts needed for this procedure:

1	Fitting cap
3	Cap (quick coupler)
3	Retainer

Removing the Pressure Transducer from the Section Valve

1. Remove and retain the flange clamp that secures the ported-fitting cap, pressure transducer, and gasket to the 90° elbow at the end of the right-section valve, and remove the cap, transducer, and gasket.

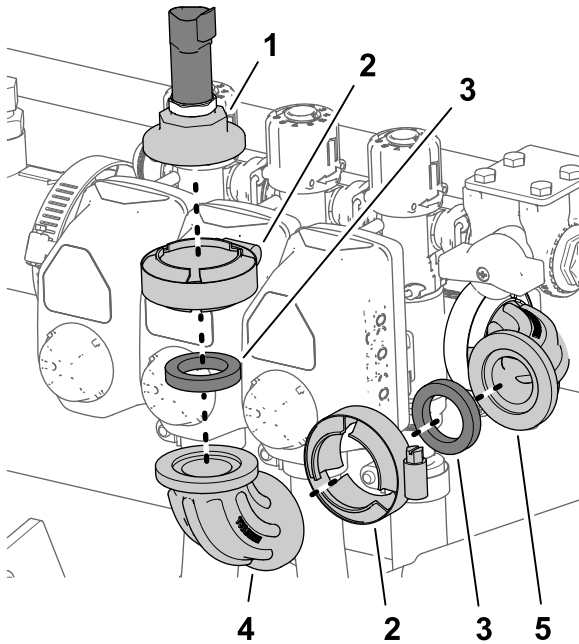

Figure 24

g187815

1. Pressure transducer and ported-fitting cap
2. Flange clamp
3. Gasket
4. 90° elbow (non-ported—right-section valve)
5. Ported 90° elbow

2. Remove the flange clamp, 90° elbow (non-ported), and gasket from the ported 90° elbow.

3. Secure the fitting cap and gasket to the 90° elbow with the previously removed flange clamp.

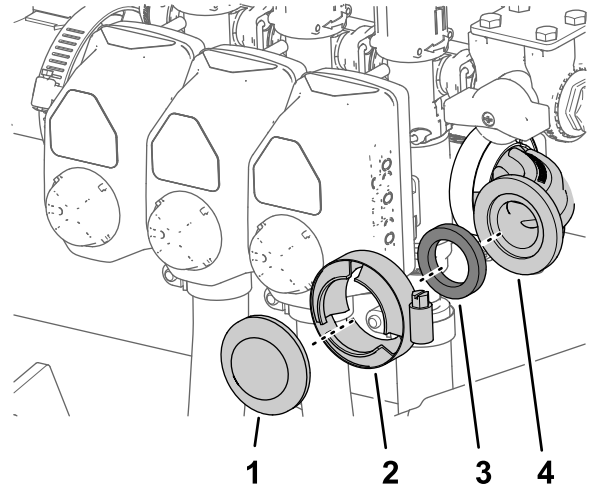

Figure 25

g187813

1. Fitting cap
2. Flange clamp
3. Gasket
4. Ported 90° elbow

Removing the Coupling Tube and Reducer Adapter

1. Loosen the 4 flange-head bolts (1/4 x 3/4 inch) and 4 flange locknuts (1/4 inch) that secure the 3 section valves to the manifold mount.

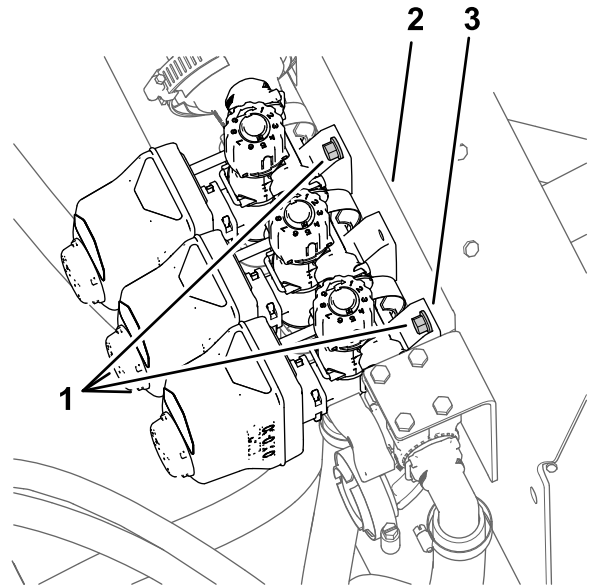

Figure 26

g187814

1. Flange-head bolts (1/4 x 3/4 inch)
2. Valve housing (section valve)
3. Manifold mount

- Remove the flange clamp and gasket that secures the reducer adapter to the left boom-section valve.

Note: Do not remove the reducer adapter or the flow meter.

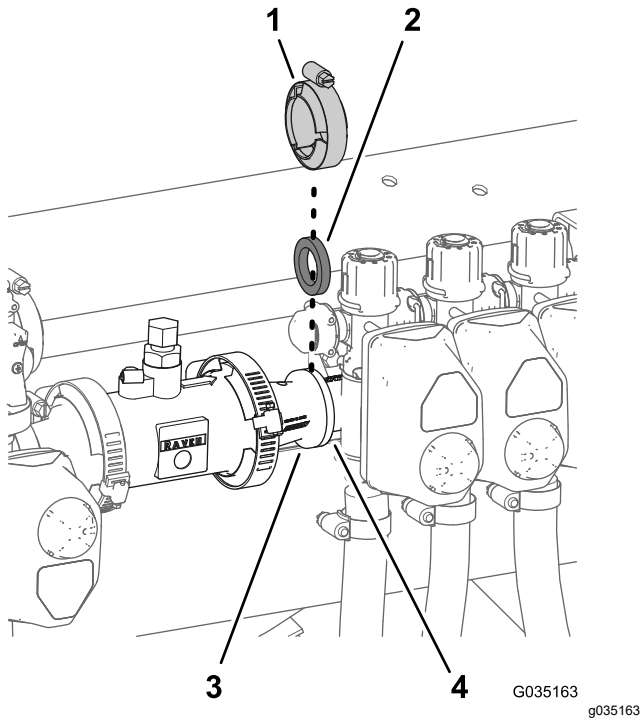

Figure 27

- | | |
|--|-------------------------------------|
| 1. Flange clamp 51 mm (2 inches) | 3. Reducer adapter |
| 2. Gasket (1-5/16 inch outside diameter) | 4. Flange (left boom-section valve) |

Removing the Boom-Section Hoses

- At the outer boom section, remove the hose clamp that secures the supply hose for the boom section to the barbed T-fitting.

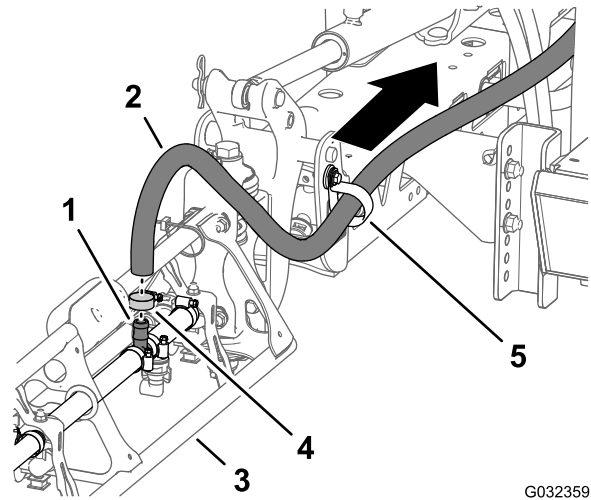

Figure 28

- | | |
|-------------------------------------|---------------|
| 1. Barbed T-fitting | 4. Hose clamp |
| 2. Supply hose (outer-boom section) | 5. R-clamp |
| 3. Outer-boom section | |

- Remove the hose from the T-fitting.
- Remove the free end of the hose from the R-clamp.
- Repeat steps 1 through 3 for the supply hose at the other outer-boom section.
- Under the center-boom section, remove the hose clamp that secures the supply hose for the boom section to the barbed T-fitting.

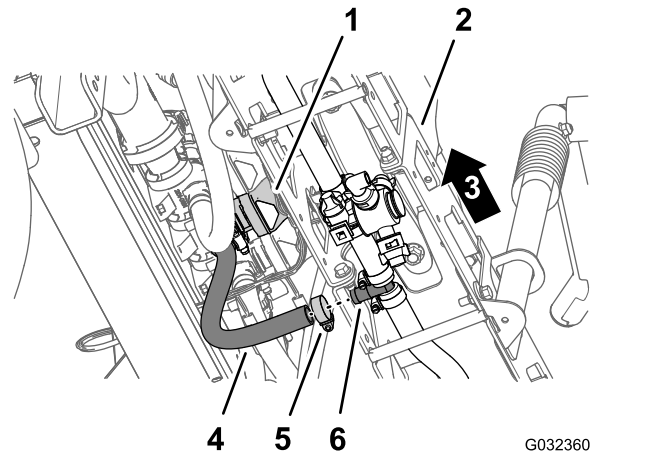

Figure 29

- | | |
|------------------------------|-------------------------------|
| 1. Center boom-section valve | 4. Hose (center-boom section) |
| 2. Center-boom section | 5. Hose clamp |
| 3. Left side of the machine | 6. Barbed T-fitting |

- Remove the retainers that secure the straight barbed fittings to the quick disconnect fittings of the left, center, and right boom-section valves.

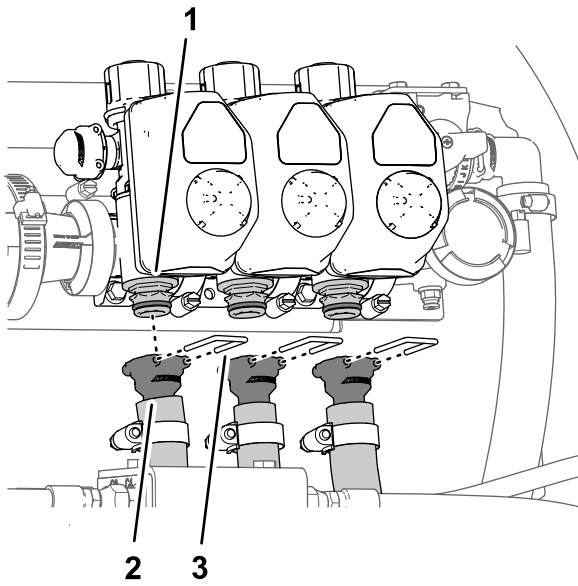

Figure 30

g187838

1. Quick disconnect fitting (boom section valve)
2. Straight barbed fitting
3. Retainer

7. Remove and discard the hoses for the left, center, and right boom section valves from the machine.

Removing the Bypass Hoses

1. At the lower end of the upper bypass hose, remove the flange-head bolt (5/16 x 3/4 inch), washer (5/16 inch), and R-clamp that secures the upper bypass hose to the rear-saddle plate of the machine.

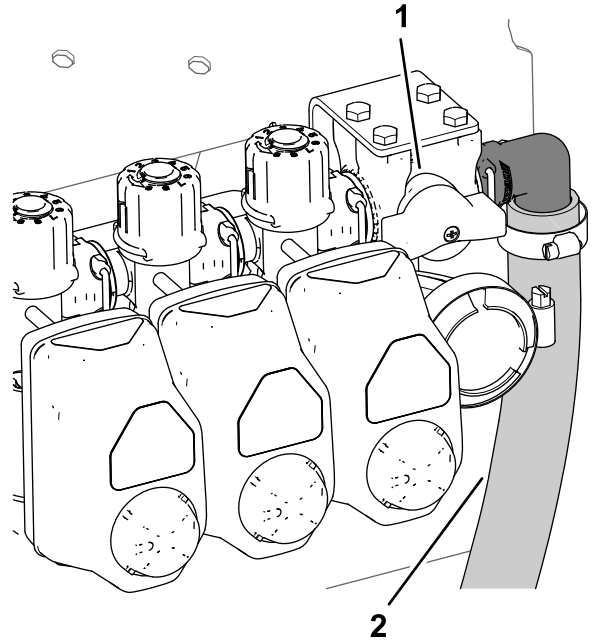

Figure 31

g187826

1. Bypass-shutoff valve
2. Upper bypass hose

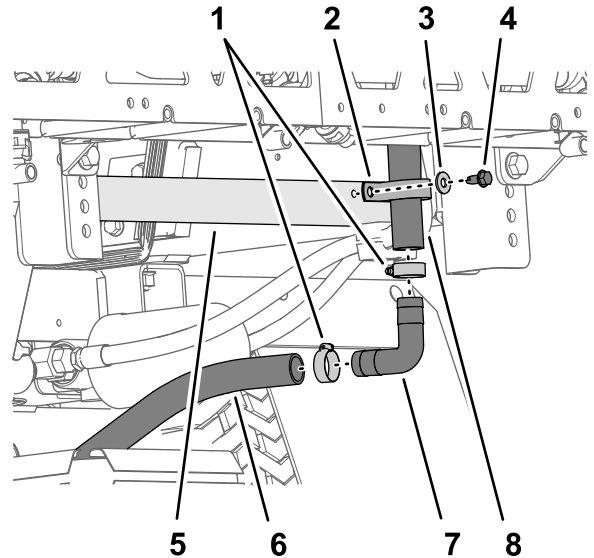

Figure 32

g189630

1. Hose clamp
2. R-clamp
3. Washer (5/16 inch)
4. Flange head bolt (5/16 x 3/4 inch)
5. Rear saddle plate (chassis frame)
6. Lower bypass hose
7. 90° barbed fitting
8. Upper bypass hose

- Remove and retain the 2 hose clamps that secure the upper bypass hose and the lower bypass hose to the 90° barbed fitting.
- Remove and retain the 90° barbed fitting from the hoses.
- Remove the hose clamps that secure the drain-valve hose and the rear tank-drain hose to the barbed T-fitting.

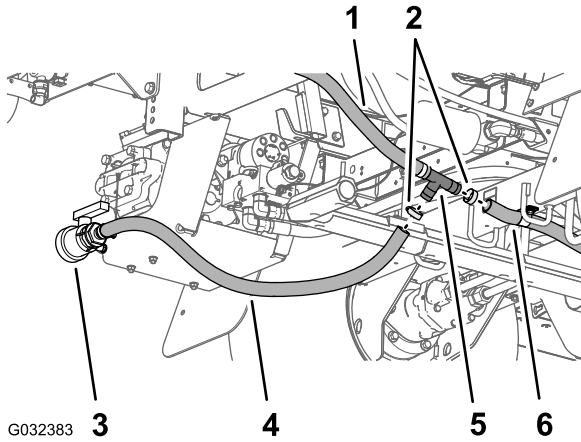

Figure 33
2016 Machine

- | | |
|----------------------|-------------------------|
| 1. Lower bypass hose | 4. Drain valve hose |
| 2. Hose clamp | 5. Barbed T-fitting |
| 3. Drain valve | 6. Rear tank-drain hose |

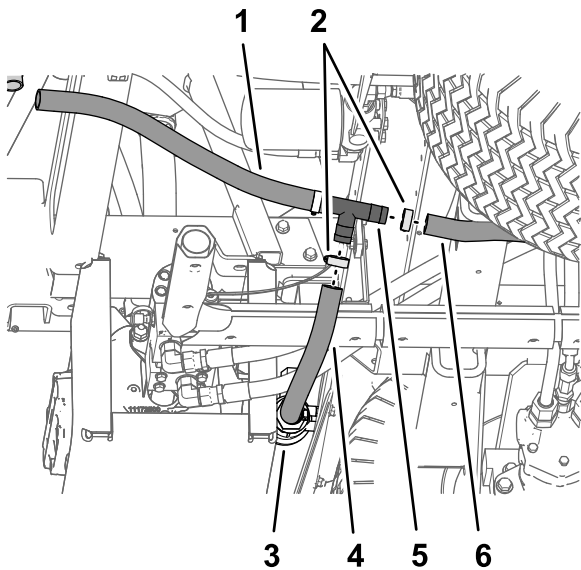

Figure 34
2017 and later machine

- | | |
|----------------------|-------------------------|
| 1. Lower bypass hose | 4. Drain valve hose |
| 2. Hose clamp | 5. Barbed T-fitting |
| 3. Drain valve | 6. Rear tank-drain hose |

- Remove the T-fitting from the drain-valve hose from the rear tank-drain hose.

- Remove the retainer that secures the 90° barbed fitting of the bypass hose to the quick-disconnect fitting of the bypass valve at the right boom-section valve, and separate the hose and valve fittings.

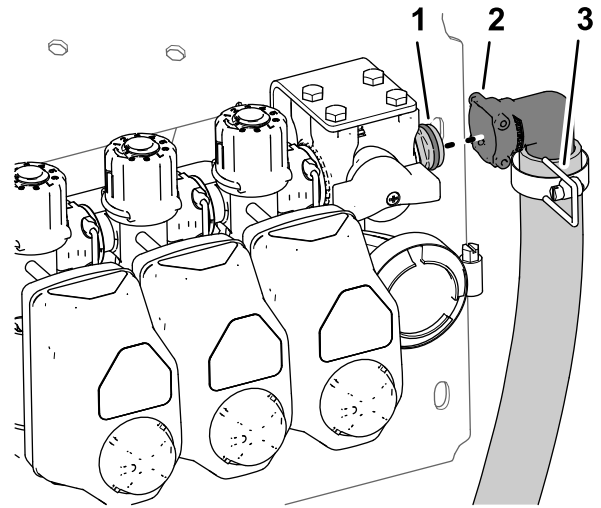

Figure 35

- | | |
|-----------------------------|-------------|
| 1. Quick disconnect fitting | 3. Retainer |
| 2. 90° barbed fitting | |

- Remove the upper and lower bypass hoses from the machine.

Note: You no longer need the shutoff valve, T-fitting, upper bypass hose, and lower bypass hose.

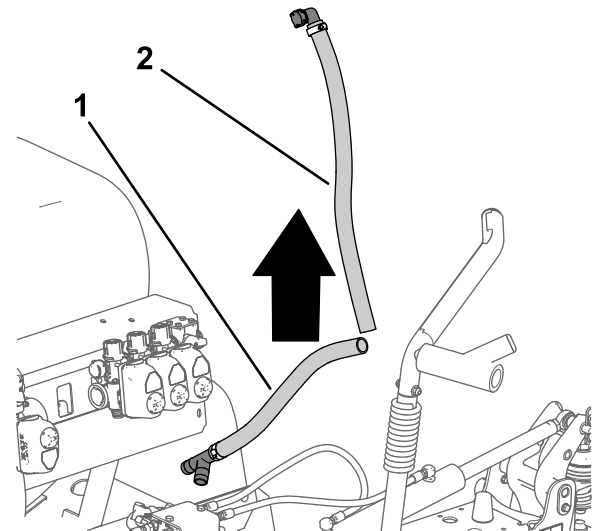

Figure 36

- | | |
|----------------------|----------------------|
| 1. Lower bypass hose | 2. Upper bypass hose |
|----------------------|----------------------|

- Insert the 90° barbed fitting that you removed in step 3 into the drain-valve hose and the rear tank-drain hose.

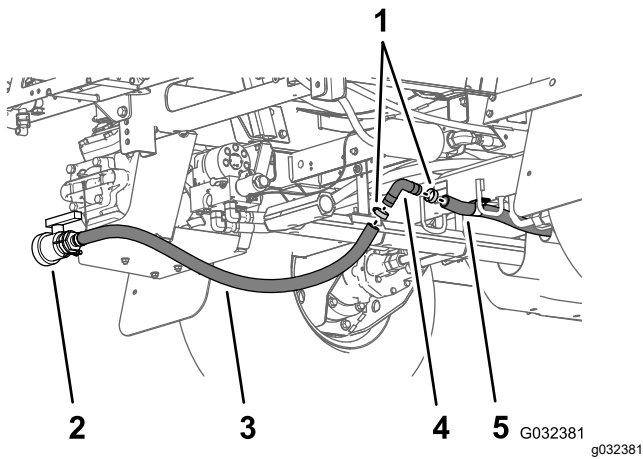

Figure 37
2016 Machines

- | | |
|---------------------|-------------------------|
| 1. Hose clamp | 4. 90° barbed fitting |
| 2. Drain valve | 5. Rear tank-drain hose |
| 3. Drain-valve hose | |

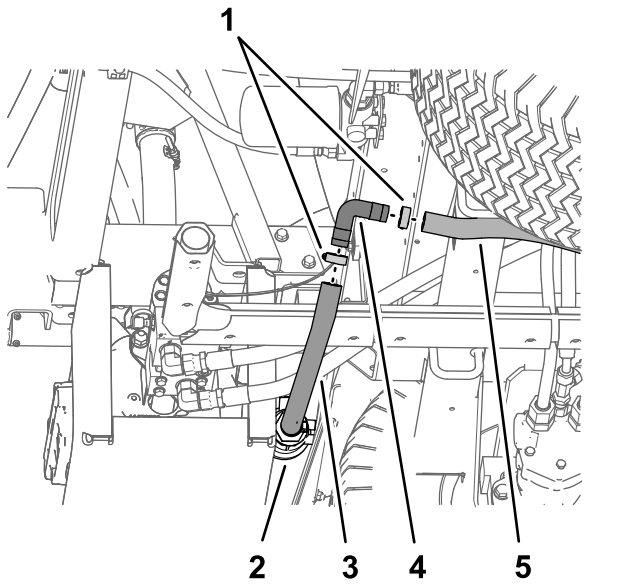

Figure 38
2017 and later machines

- | | |
|---------------------|-------------------------|
| 1. Hose clamp | 4. 90° barbed fitting |
| 2. Drain valve | 5. Rear tank-drain hose |
| 3. Drain-valve hose | |

9. Secure the 90° barbed fitting and drain hoses with the 2 hose clamps that you removed in step 2.

Removing the Valve Actuator

1. Remove and retain the retainer that secures the actuator to the manifold valve of the section valve assembly.

Note: Squeeze the 2 legs of the retainer together while pushing it down.

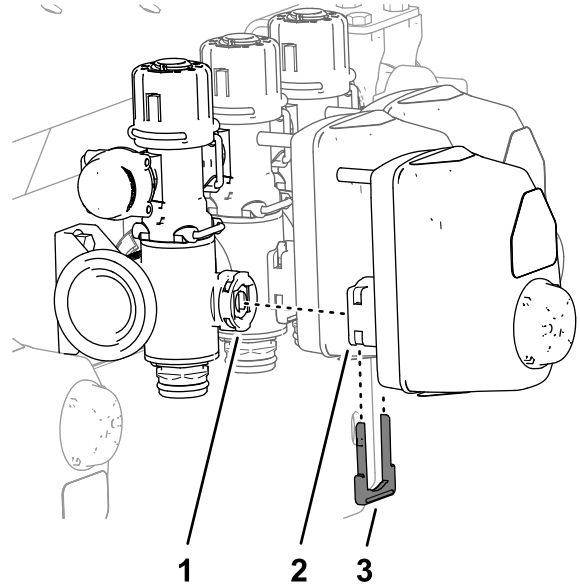

Figure 39

- | | |
|-------------------------------|-------------|
| 1. Stem port (manifold valve) | 3. Retainer |
| 2. Actuator (section valve) | |

2. Remove and retain the actuator from the manifold valve.
3. Repeat these steps for the 2 other valve actuators.

Removing the Bypass Shutoff Valve and Installing the Bypass Valve with Caps

1. Remove the 4 bolts (6 x 12 mm) that secure the bypass shutoff valve to the valve support bracket.
2. Remove the retainer that secures the bypass-shutoff valve to the bypass valve for the right boom section valve, and remove the shutoff valve (.

Note: You no longer need the bypass-shutoff valve and the 4 bolts (6 x 12 mm).

3. Remove the 3 retainers that secure the 3 bypass valves to the 3 manifold valves.

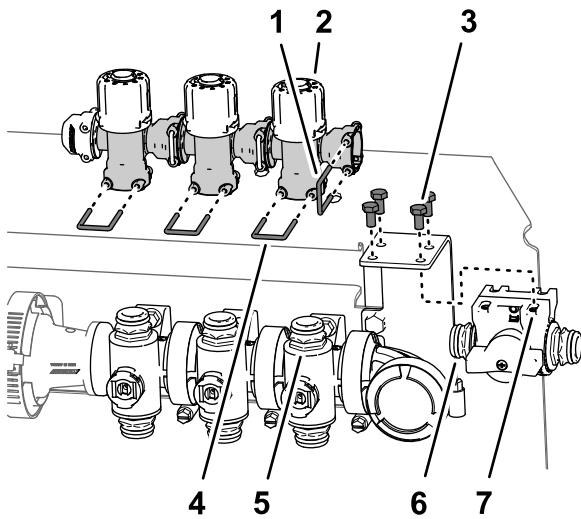

Figure 40

g187902

- | | |
|-----------------------------------|---|
| 1. Retainer | 5. Quick coupler (bypass-shutoff valve) |
| 2. Bypass valves | 6. Bypass-shutoff valve |
| 3. Bolt (6 x 12 mm) | 7. Valve mount |
| 4. Quick coupler (manifold valve) | |

- Remove and discard the 3 bypass valves from the 3 quick couplers of the manifold valves.
- Lubricate the upper and lower O-rings on the quick coupler of the manifold valve with the grease provided with the quick coupler cap.

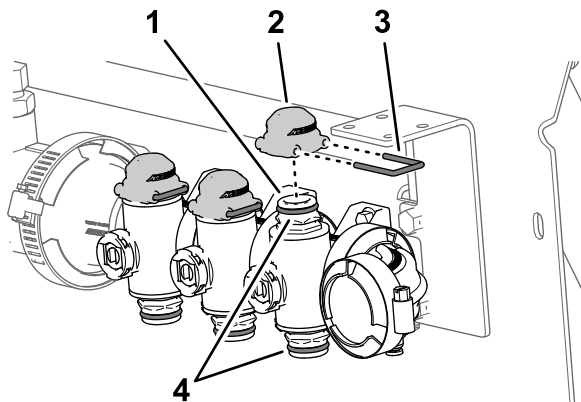

Figure 41

g187927

- | | |
|-----------------------------------|-------------|
| 1. Quick coupler (manifold valve) | 3. Retainer |
| 2. Cap (quick coupler) | 4. O-rings |

- Assemble the 3 caps for the quick couplers onto the 3 quick couplers for the manifold valves.
- Secure the 3 caps to the 3 quick couplers with the 3 retainers.
- Align the coupler of the previously removed section valve actuator (Figure 39) with the stem port of the manifold valve.

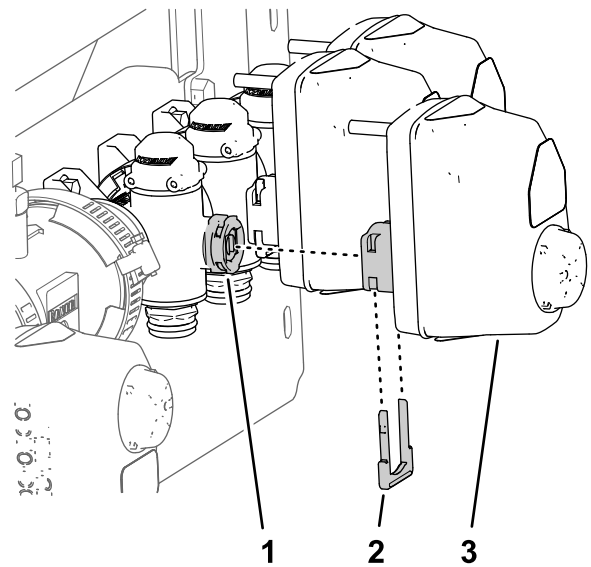

Figure 42

g187925

- | | |
|-------------------------------------|-------------------------------|
| 1. Retainer | 3. Stem port (manifold valve) |
| 2. Coupler (section-valve actuator) | |

- Secure the section valve actuator to the manifold valve with the previously removed retainer (Figure 39) as shown in Figure 42.

Disassembling the Boom Section Valves from the Manifold Mount

Note: You will add the boom-section valves to the valves for the 10 valve system in [Assembling Spray Valves 8, 9, and 10 to the Valve Mount](#) (page 24).

- Remove the 2 flange head bolts (1/4 x 3/4 inch) and 2 locknuts (1/4 inch) that secure the right boom-section valve to the manifold mount.

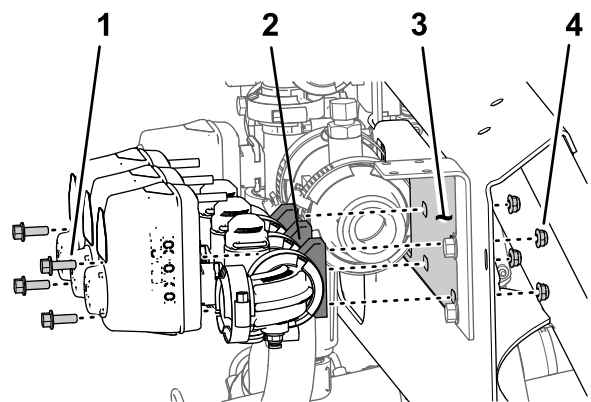

Figure 43

g187928

- | | |
|--------------------------------------|-----------------------|
| 1. Flange head bolt (1/4 x 3/4 inch) | 3. Manifold mount |
| 2. Boom section valve | 4. Locknut (1/4 inch) |

2. Remove the 2 flange head bolts (1/4 x 3/4 inch) and 2 locknuts (1/4 inch) that secure the left boom-section valve to the manifold mount.
3. Remove the boom section valves from the manifold mount and set aside the valves.

Note: Retain the boom section valves. Discard the 4 flange-head bolts and 4 locknuts.

4. Remove the 6 decals from the 3 boom-section valves.

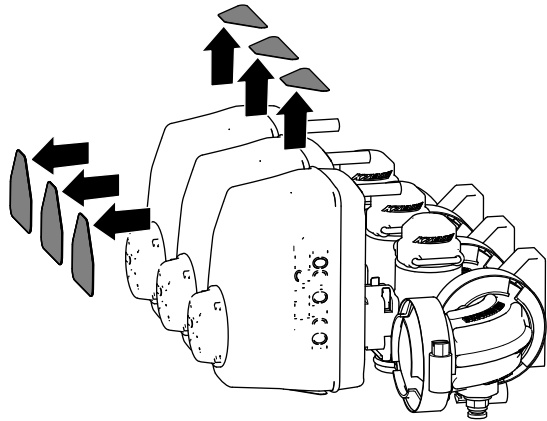

Figure 44

g187926

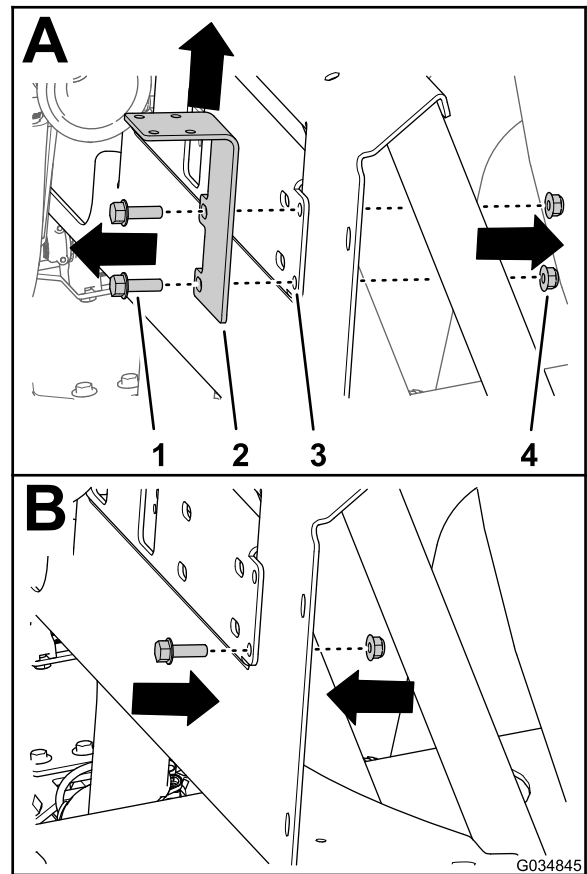

Figure 45

G034845

g034845

5. Remove the 2 flange head bolts (5/16 x 1 inch) and 2 flange locknuts (5/16 inch) that secure the support bracket for the bypass-shutoff valve to the manifold mount (A of [Figure 45](#)), and remove the shutoff-valve bracket.

1. Flange head bolt (5/16 x 1 inch)
2. Support bracket (bypass shutoff valve)
3. Manifold mount
4. Flange locknuts (5/16 inch)

6. Assemble a flange head bolt (5/16 x 1 inch) and flange locknut (5/16 inch) to the manifold mount (B of [Figure 45](#)) at the lower hole position for the shutoff valve bracket.

Note: Retain the other flange head bolt and flange locknut.

7. Torque the flange bolt and flange nut to 1978 to 2542 N·cm (175 to 225 in·lb).

8

Relocating the Pressure Transducer

Parts needed for this procedure:

1	Barbed-flange fitting (1 inch)
1	Hose (1 x 7-1/4 inches)
3	Hose clamp
1	Pressure transducer
1	Manifold
1	Hose (1 x 8-1/2 inches)
1	R-clamp

Assembling the Pressure Transducer to the Manifold

1. Align the ported fitting cap with pressure transducer and gasket to the T-fitting flange of the manifold.

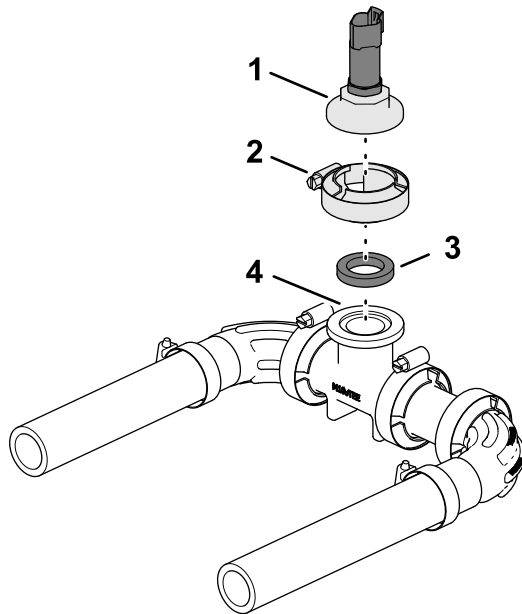

Figure 46

g187688

- | | |
|---|-------------------------|
| 1. Pressure transducer and ported fitting cap | 3. Gasket |
| 2. Flange clamp | 4. T-fitting (manifold) |

2. Secure the fitting cap and gasket to the T-fitting with the flange clamp.

Installing the Pressure-Transducer Manifold

1. Assemble the hose (1 x 7-1/4 inches) onto the barbed elbow fitting of the pressure transducer and manifold.

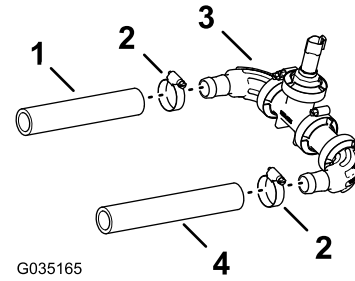

G035165

g035165

Figure 47

- | | |
|----------------------------|-------------------------------------|
| 1. Hose (1 x 7-1/4 inches) | 3. Pressure transducer and manifold |
| 2. Hose clamp | 4. Hose (1 x 8-1/2 inches) |

2. Secure the hose and barbed fittings with a hose clamp.
3. Assemble the hose (1 x 8-1/2 inches) onto the other barbed elbow-fitting of the pressure transducer and manifold.
4. Secure the hose and barbed fitting with a hose clamp.

Installing the Pressure Transducer onto the Machine

1. Assemble the hose (1 x 7-1/4 inches) that is attached to the pressure transducer and manifold onto the barbed flange fitting (1 inch).

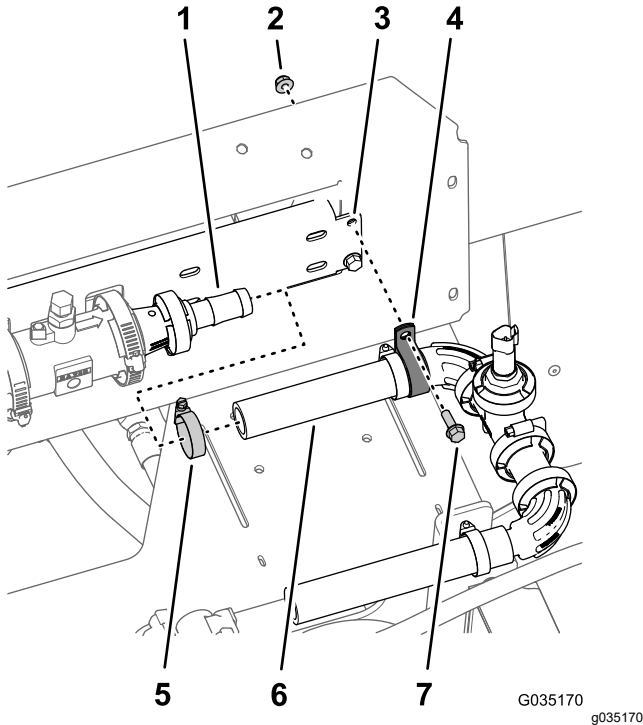

Figure 48

- | | |
|-----------------------------------|--------------------------------------|
| 1. Barbed flange fitting (1 inch) | 5. Hose clamp |
| 2. Flange locknut (1/4 inch) | 6. Hose (1 x 7-1/4 inches) |
| 3. Slot (Manifold mount) | 7. Flange-head bolt (1/4 x 3/4 inch) |
| 4. R-clamp | |

2. Loosely secure the hose to the barbed flange fitting with a hose clamp.
3. Secure the pressure transducer and manifold to the slot in the manifold mount with a R-clamp and the previously removed (Figure 45) flange head bolt (1/4 x 3/4 inch) and flange locknut (1/4 inch).

9

Installing the Valve Mount, Rate/Section Controller, and Section Valves

Parts needed for this procedure:

1	Valve mount and valve assembly
1	Rate/Section controller
4	Magnet
4	Bolt (#8)
4	Washer (8)
4	Locknut (#8)
8	Flange-head bolts (5/16 x 3/4 inch)
8	Flange locknuts (5/16 inch)
1	Hose clamp
2	Flange head bolt (1/4 x 3/4 inch)
2	Flange locknut (1/4 inch)

Assembling the Valve Mount and Valve Assembly to the Machine

Lifting equipment capacity: 23 kg (50 lb)

1. Using lifting equipment with the specified capacity, lift the valve mount and valve assembly and align it over the center boom section.

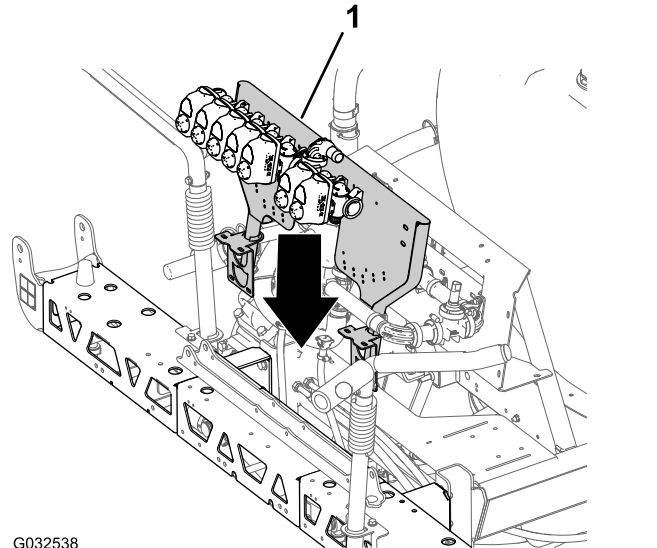

Figure 49

1. Valve mount and valve assembly

- Align the holes on the mount bracket of the valve mount to the holes on the truss frame of the center-boom section.

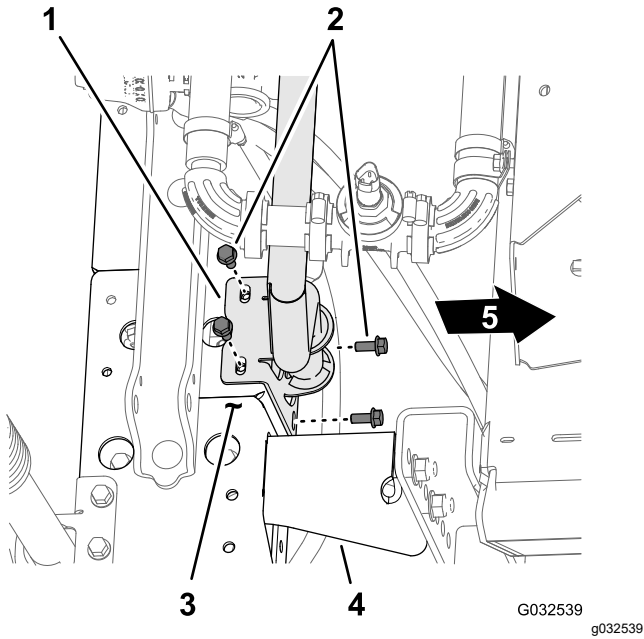

Figure 50

- Mount bracket (valve mount)
- Flange head bolt (5/16 x 3/4 inch)
- Truss frame (center boom section)
- Support bracket
- Front of the machine

- Assemble the valve mount to the truss frame with 4 bolts (5/16 x 3/4 inch) and 4 flange locknuts (5/16 inch).

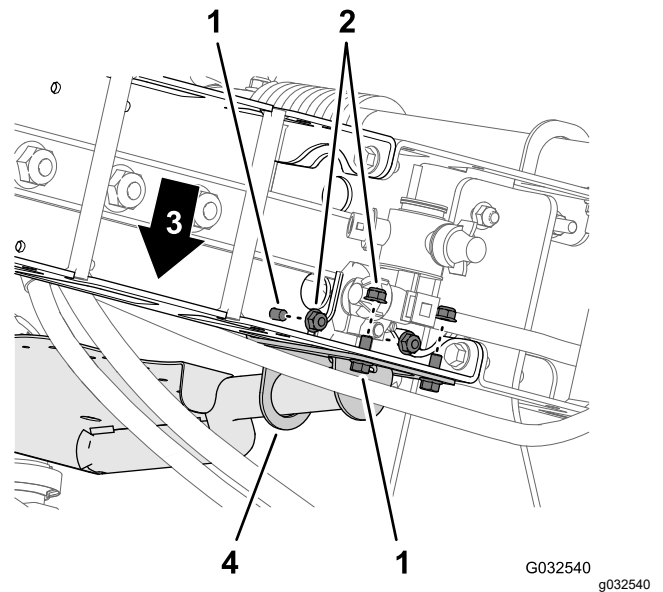

Figure 51

- Flange head bolt (5/16 x 3/4 inch)
- Flange locknuts (5/16 inch)
- Front of the machine
- Mount bracket (valve mount)

- Repeat the above steps for the other mount bracket of the valve mount at the other truss frame.
- Torque the flange-head bolts and flange locknuts to 1978 to 2542 N·cm (175 to 225 in-lb).

Assembling the Hose to the Spray Valve Manifold

- Assemble the hose (1 x 8-1/2 inches) over the 90° flange fitting (1 inch).

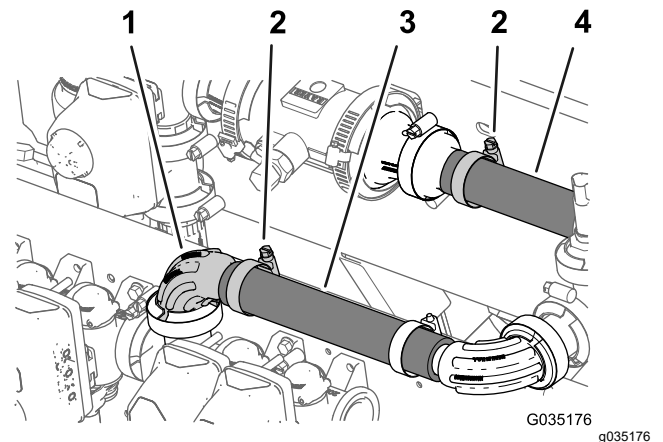

Figure 52

- 90° flange fitting (1 inch)
- Hose clamp
- Hose (1 x 8-1/2 inches)
- Hose (1 x 7-1/4 inches)

- Secure the hose to the flange fitting with a hose clamp.

- Tighten the hose clamp that secures the hose (1 x 7-1/4 inches) to the barbed-flange fitting (1 inch) that you assembled in [Installing the Pressure Transducer onto the Machine \(page 22\)](#); refer to [Figure 52](#).

Assembling Spray Valves 8, 9, and 10 to the Valve Mount

Important: The left boom-section valve that you removed in step 3 of [Disassembling the Boom Section Valves from the Manifold Mount \(page 19\)](#) is identified as nozzle-valve 8, the center boom-section valve is identified as nozzle-valve 9, and the right boom-section valve is identified as nozzle-valve 10 for the remainder of the GeoLink finishing kit installation instructions.

- Align the gasket and the flange of the left section valve (identified as nozzle valve 8) with the flange of nozzle valve 7.

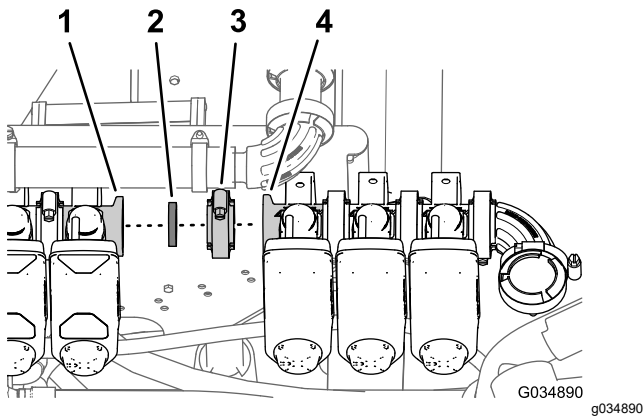

Figure 53

- Flange (nozzle valve 7)
- Gasket
- Flange clamp
- Flange (nozzle valve 8)

- Loosely secure the gasket and nozzle-valve 8 to nozzle valve 7 with a flange clamp.
- Assemble nozzle-valve 10 to the valve mount with the previously removed ([Figure 43](#)) 2 flange-head bolts (1/4 x 3/4 inch) and 2 flange locknuts (1/4 inch).

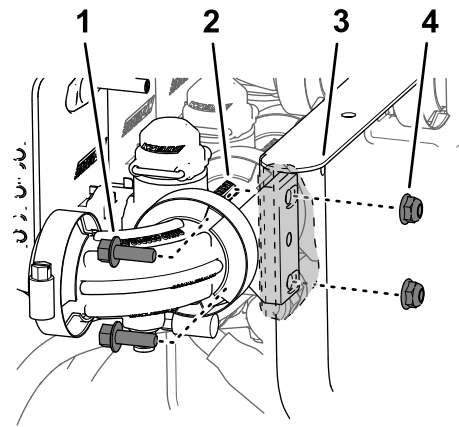

Figure 54

- Flange head bolt (1/4 x 3/4 inch)
- Nozzle-valve 10
- Valve mount
- Flange locknut (1/4 inch)

- Torque the flange-head bolt and locknut to 1017 to 1234 N-cm (90 to 120 in-lb).
- Tighten the flange clamp by hand.

Installing the Rate/Section Controller to the Valve Mount

- Install the magnets to the rate/section controller using 4 bolts (#8) and 4 locknuts (#8).

Note: Hand tighten an additional quarter turn to secure the assembly. Overtightening can damage the magnets.

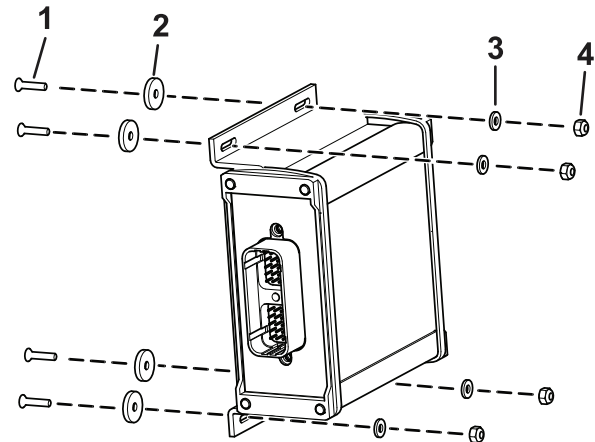

Figure 55

- Bolt (#8)
- Magnet
- Washer
- Nut (#8)

- Place the controller assembly onto the valve mount.

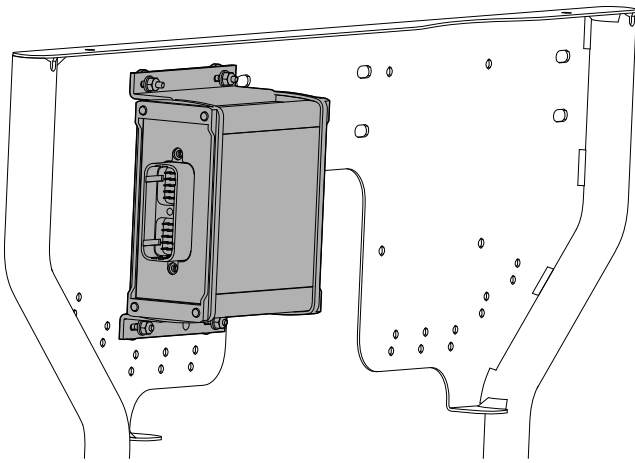
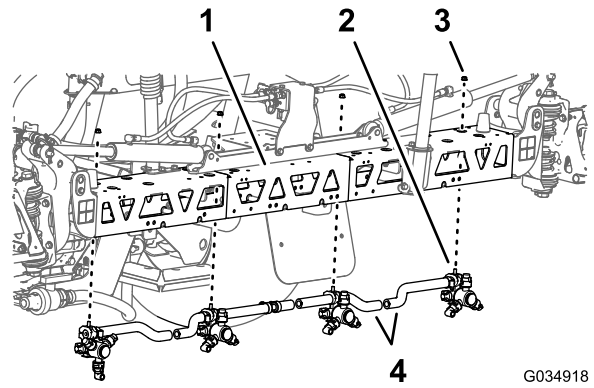

Figure 56

g421245



G034918

g034918

Figure 58

- | | |
|------------------------|------------------------------------|
| 1. Center boom section | 3. Flange locknut (5/16 inch) |
| 2. Turret | 4. Hose (3/4 inch inside diameter) |

10

Removing the Hoses for the 3-Section System

No Parts Required

Procedure

1. Cut the hoses between the turrets.

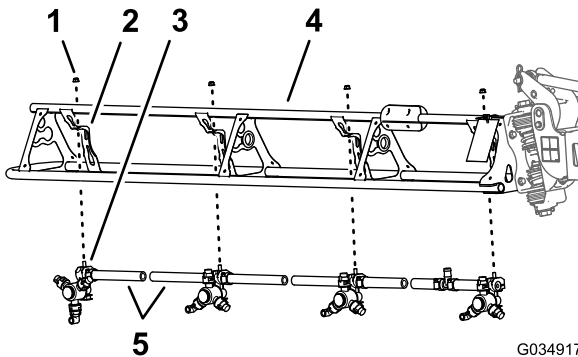

G034917

g034917

Figure 57

- | | |
|-------------------------------|------------------------------------|
| 1. Flange locknut (5/16 inch) | 4. Outer boom section |
| 2. Turret support | 5. Hose (3/4 inch inside diameter) |
| 3. Turret | |

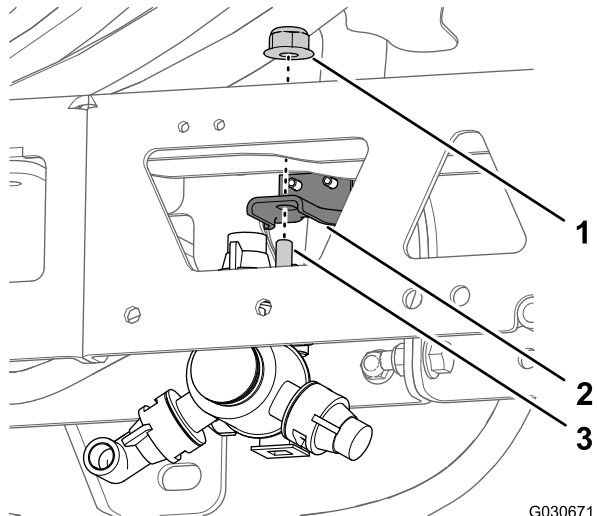

G030671

g030671

Figure 59

- | | |
|---------------------------|------------------------------------|
| 1. Flange nut (5/16 inch) | 3. Hex-head bolt (5/16 x 3/4 inch) |
| 2. Turret mount | |

3. Remove the stainless steel screws (#12 x 1-1/4 inches) and remove the barbed-hose shanks.

Note: The hex head bolt (5/16 x 3/4 inch—stainless steel) will separate from the upper clamp half when you open the clamp, retain the bolt for installation.

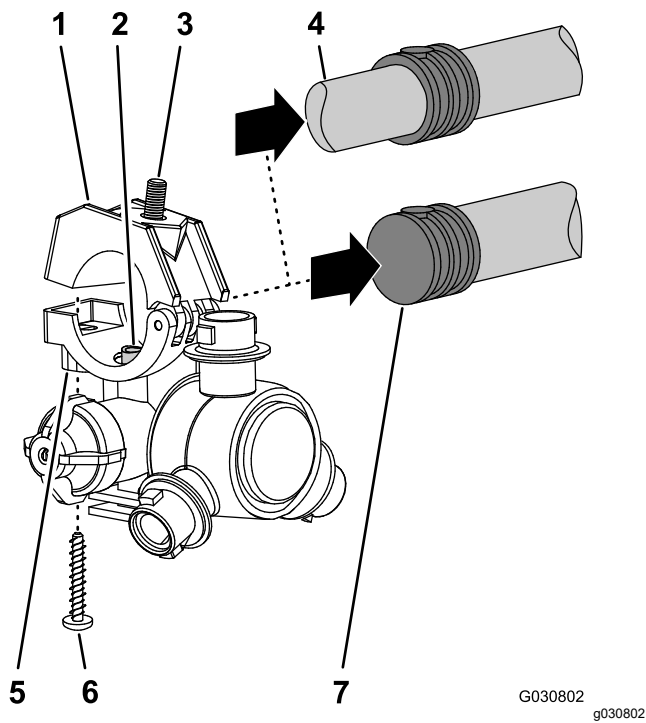

G030802
g030802

Figure 60

- | | |
|---|--|
| 1. Upper clamp half | 5. Turret |
| 2. Transfer tube | 6. Stainless steel screw (#12
x 1-1/4 inches) |
| 3. Hex head bolt (5/16 x 3/4
inch—stainless steel) | 7. Single barbed-hose shank
(3/4 inch hose) |
| 4. Double barbed-hose
shank (3/4 inch hose) | |

11

Installing the Hoses

Parts needed for this procedure:

2	Supply hose 279 cm (110 inches)
2	Supply hose 234 cm (92 inches)
4	Supply hose 188 cm (74 inches)
2	Supply hose 81 cm (32 inches)
2	R-clamp
2	Double R-clamp
2	Single R-clamp

Assembling the Hoses to Section Valves

Note: Ensure that the barbed fitting is fully seated onto the coupler.

Secure the barbed fittings to the couplers with a retainer.

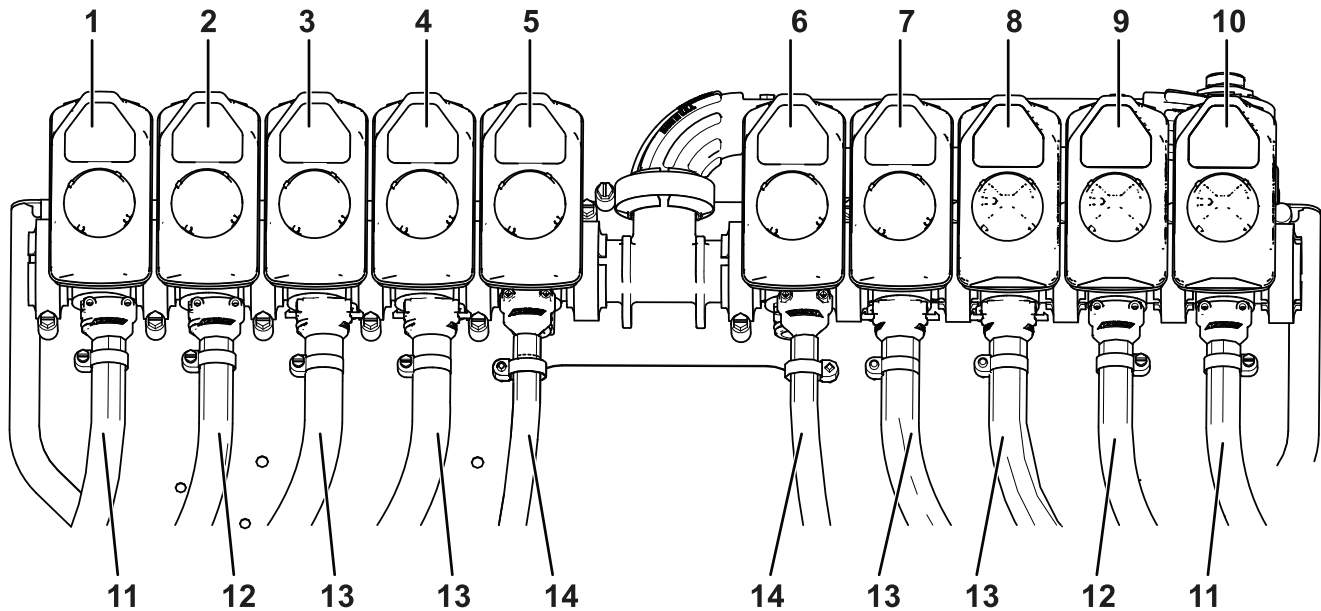

Figure 61

g412939

- | | | |
|--------------------|----------------------|-------------------------------------|
| 1. Section valve 1 | 6. Section valve 6 | 11. Supply hose 279 cm (110 inches) |
| 2. Section valve 2 | 7. Section valve 7 | 12. Supply hose 234 cm (92 inches) |
| 3. Section valve 3 | 8. Section valve 8 | 13. Supply hose 188 cm (74 inches) |
| 4. Section valve 4 | 9. Section valve 9 | 14. Supply hose 81 cm (32 inches) |
| 5. Section valve 5 | 10. Section valve 10 | |

Note: The supply hose assembly 81 cm (32 inches) has a T-fitting with 2 branch hoses and 2 single barbed-hose shanks.

Boom Section	Section valve	Nozzle	Supply Hose
Left	1	1	279 cm (110 inches)
	2	2	234 cm (92 inches)
	3	3	188 cm (74 inches)
	4	4	188 cm (74 inches)
Center	5	5 and 6	81 cm (32 inches)
	6	7 and 8	81 cm (32 inches)
Right	7	9	188 cm (74 inches)
	8	10	188 cm (74 inches)
	9	11	234 cm (92 inches)
	10	12	279 cm (110 inches)

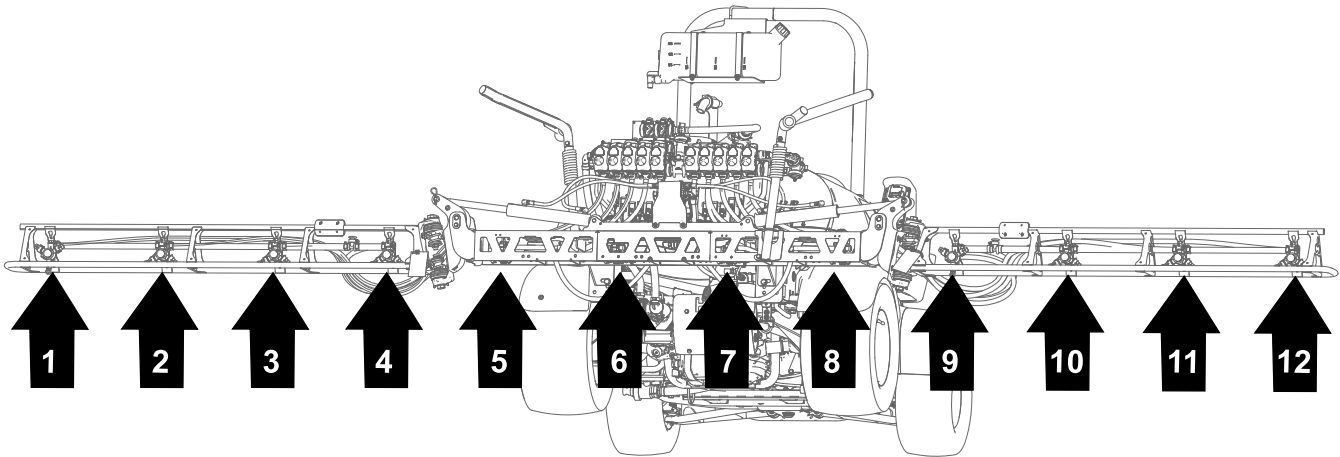
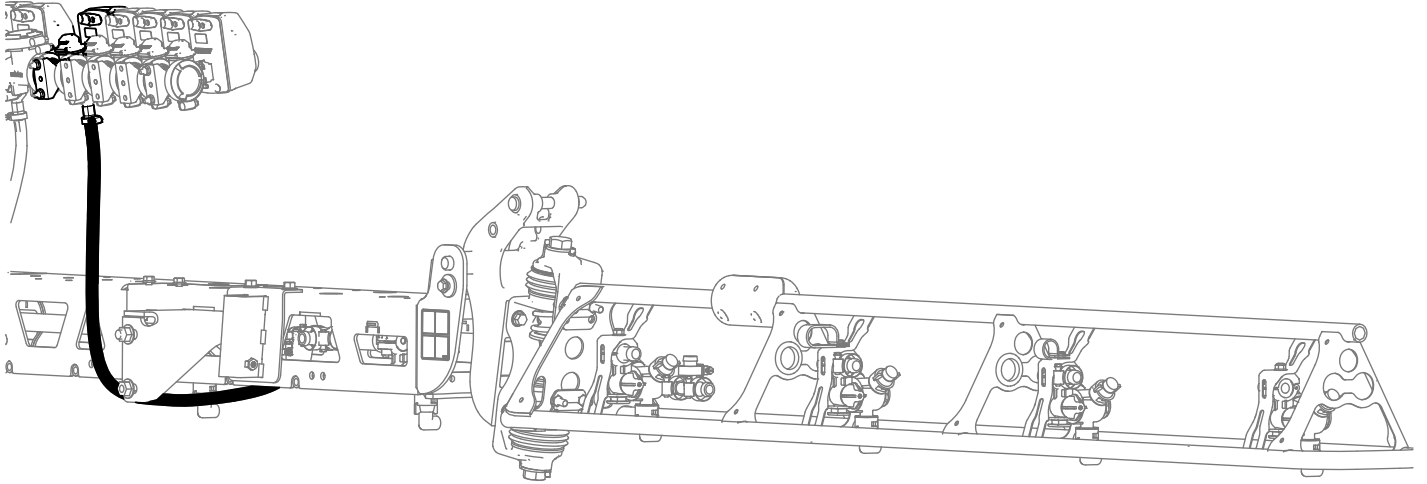

Figure 62
Nozzle Locations

g421741

Routing the Hoses

Use [Figure 63](#) through [Figure 67](#) to route the hoses. Only one side is shown. The routing is the same for both sides.



g413998

Figure 63
81 cm (32 inch) hose

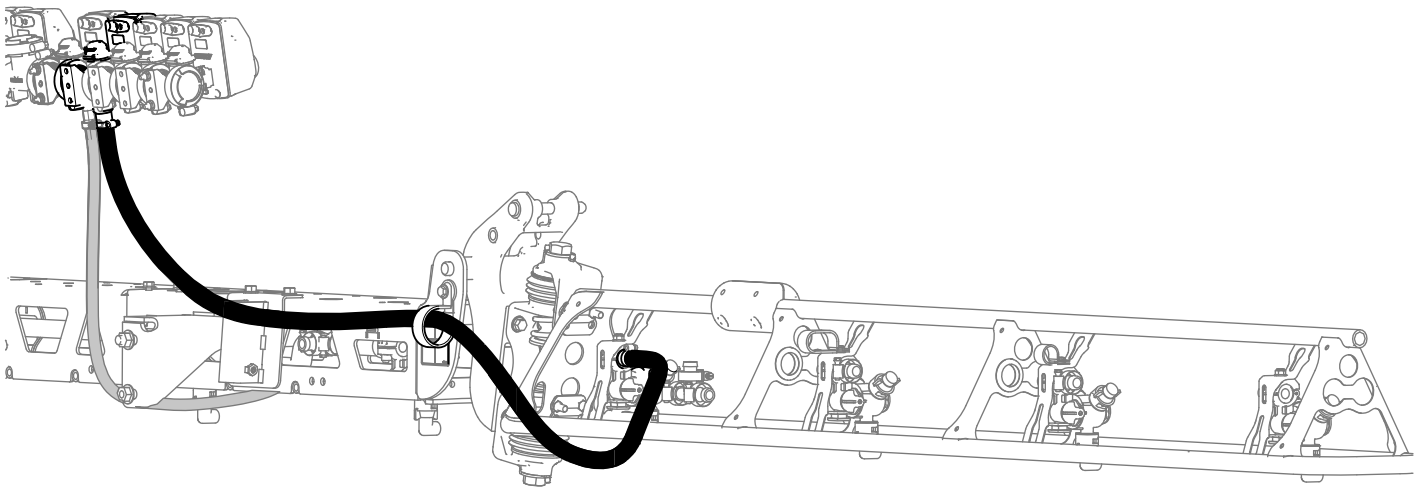

g413999

Figure 64
188 cm (74 inch) hose

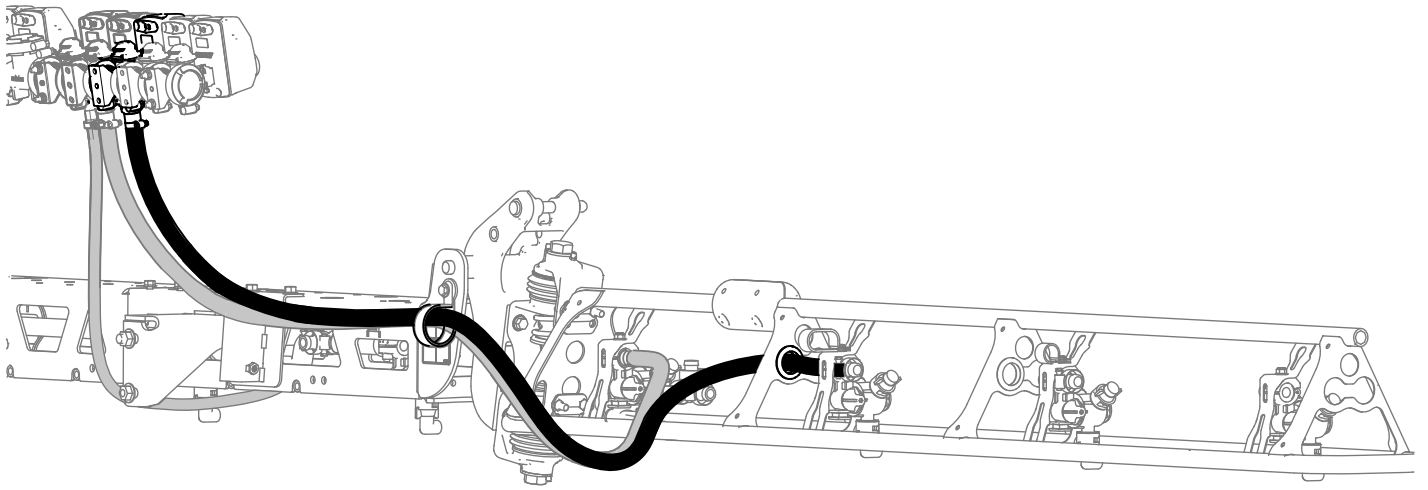

g414000

Figure 65
188 cm (74 inch) hose

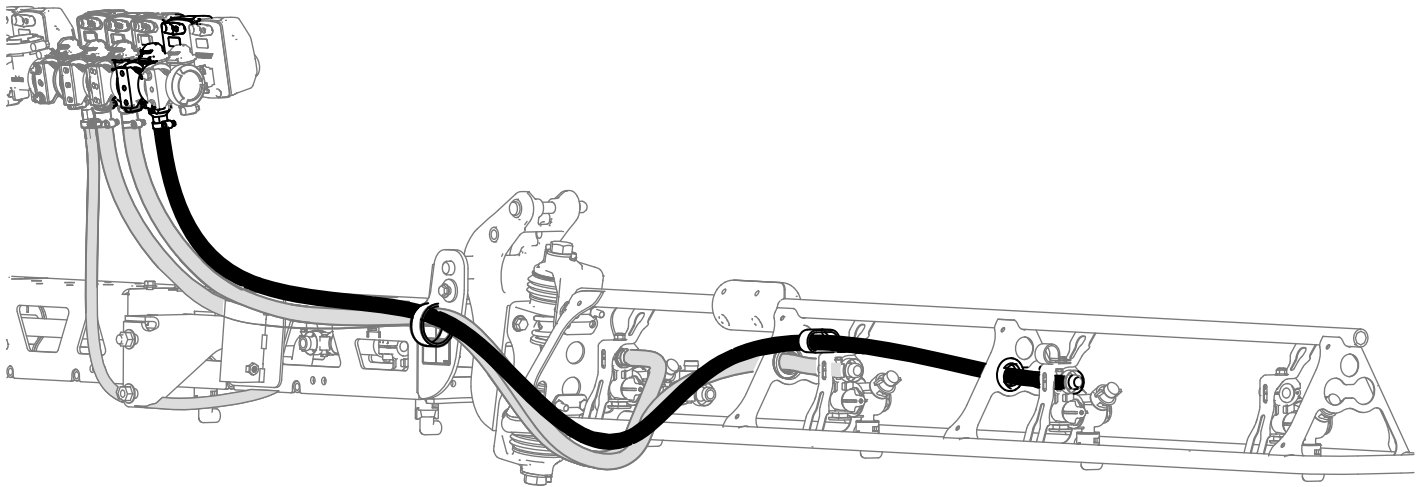

g414001

Figure 66
234 cm (92 inch) hose

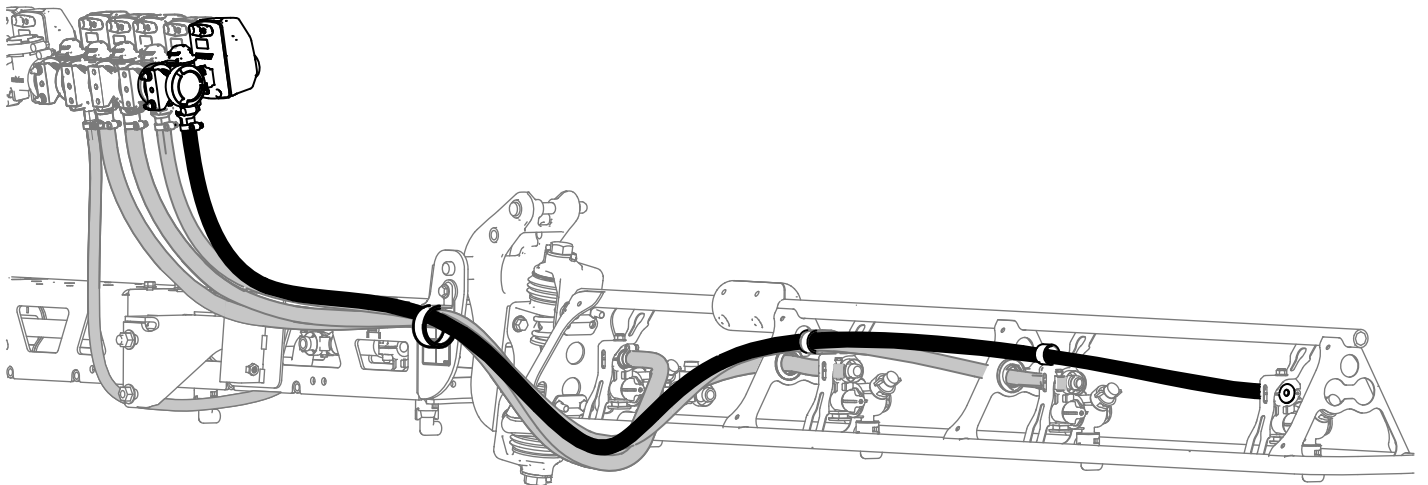

g414002

Figure 67
279 cm (110 inch) hose

Installing the Turrets at the Outer-Boom Sections

1. Align the transfer tube in the saddle of a turret [with the hole in the side of the single barbed-hose shank (1/2 inch)].

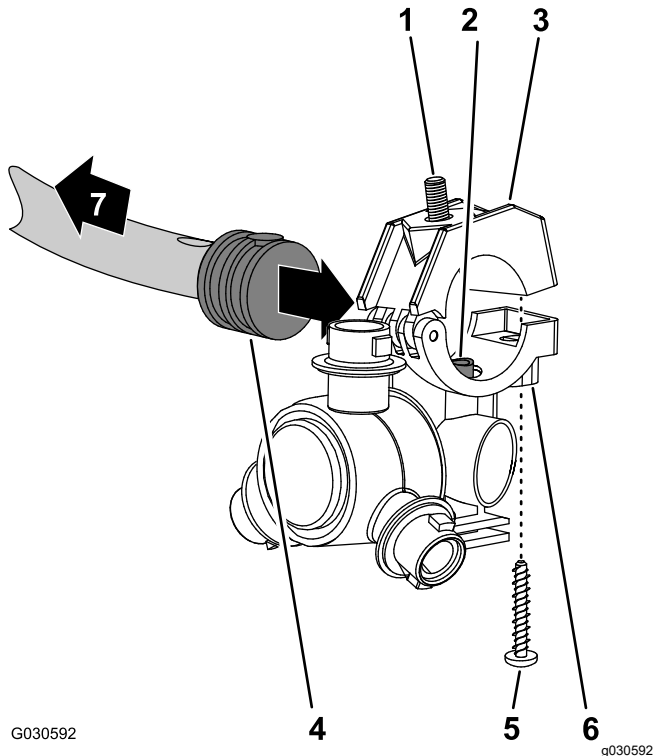

Figure 68

- | | |
|--|---|
| 1. Hex-head bolt (5/16 x 3/4 inch—stainless steel) | 5. Stainless steel screw (#12 x 1-1/4 inches) |
| 2. Transfer tube | 6. Turret |
| 3. Upper clamp half | 7. Toward the spray section |
| 4. Single barbed-hose shank (1/2 inch) | |

2. Close the upper clamp half around the barbed-hose shank and secure the clamp half and turret body with the stainless steel screw (#12 x 1-1/4 inches); torque the stainless steel screw to 14 to 18 N·m (20 to 25 in-lb).

Note: Ensure that the hex-head bolt (5/16 x 3/4 inch) is seated in the recess in the upper clamp half when closing the clamp.

3. Secure the turrets to the mounts using the previously removed flange locknuts (5/16 inch).

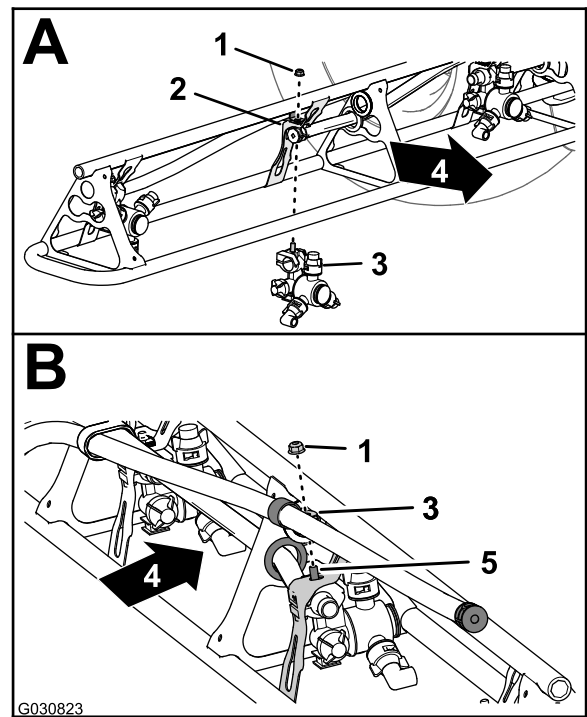

Figure 69

- | | |
|-------------------------------|--|
| 1. Flange locknut (5/16 inch) | 4. Back of the machine |
| 2. Turret mount | 5. Hex-head bolt (stainless steel—5/16 x 3/4 inch) |
| 3. Turret | |

4. Torque the flange locknut to 1978 to 2542 N·cm (175 to 225 in-lb).

Routing the Supply Hoses at the Center-Boom Section

1. Ensure that the hoses and barbed couplers 13 x 810 mm (1/2 x 32 inches) are aligned to the front of the center-boom section between the left and right support brackets for the center section.
2. Route the hose 13 mm (10 inches) and barbed-hose shank between the truss braces of the outer truss.

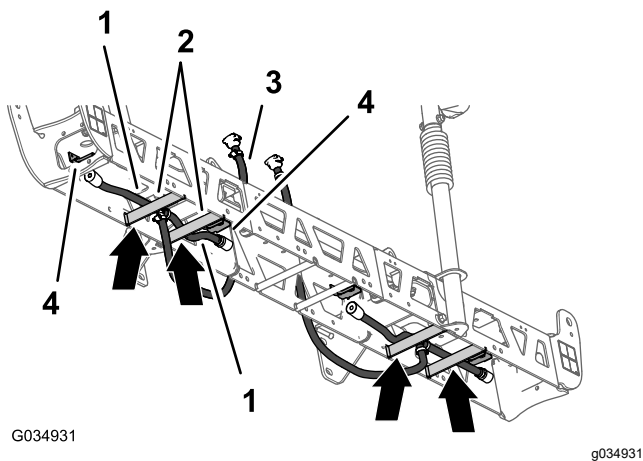

G034931

g034931

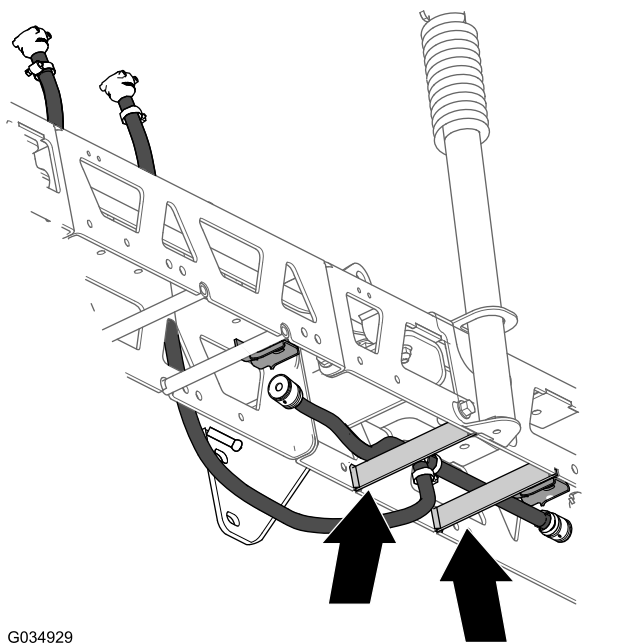

G034929

g034929

Figure 70

- | | |
|--|---|
| 1. Hoses 13 x 250 mm (1/2 x 10 inches) | 3. Hose and barbed-hose shank 13 x 810 mm (1/2 x 32 inches) |
| 2. Truss braces (left truss) | 4. Spray-nozzle mounts |

- Route the hose and barbed-hose shank above the truss brace and outward to the outboard nozzle mount.
- Route the other hose 13 mm (10 inches) and barbed-hose shank between the truss braces of the inner truss.
- Route the hose and barbed-hose shank above the truss brace and inward to the inboard nozzle mount
- Repeat steps 2 through 7 for the other hose and nozzle assembly at the other outer truss.
- Route the hose and barbed coupler 13 x 810 mm (1/2 x 32 inches) to the side of the center-boom section with the left and right support brackets for the boom section.

Assembling the Turrets and Hoses for the Center Boom Section

- Remove the stainless steel screw that secures the upper clamp halves to the saddle.

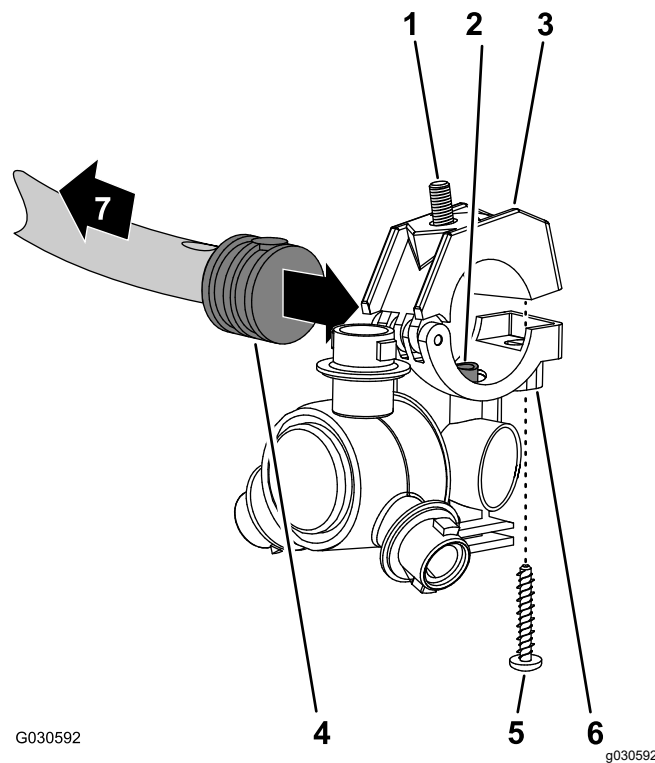

G030592

g030592

Figure 71

- | | |
|--|---|
| 1. Hex head bolt (5/16 x 3/4 inch—stainless steel) | 5. Stainless steel screw (#12 x 1-1/4 inches) |
| 2. Transfer tube | 6. Turret |
| 3. Upper clamp half | 7. Toward the boom section |
| 4. Single barbed hose shank (1/2 inch) | |

- Locate the hole in the side of single barbed-hose shank at the end of the hose 25 cm (10 inches) of the hose assembly (spray valve 5 or 6) for the center-boom section.

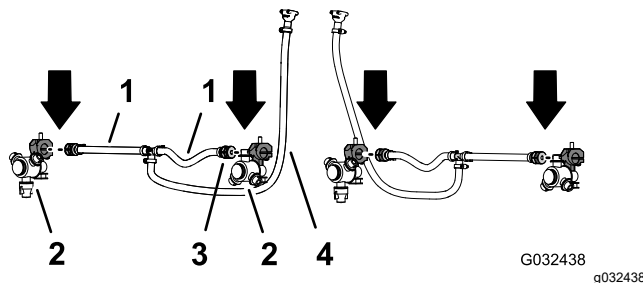

G032438

g032438

Figure 72

- | | |
|--|---|
| 1. Hose 13 x 250 mm (1/2 x 10 inches—valve 5 or 6) | 3. Single barbed hose shank 13 mm (1/2 inch) |
| 2. Turret | 4. Hose and barbed coupler 13 x 810 mm (1/2 x 32 inches—valve 5 or 6) |

3. Align the transfer tube in the saddle of a turret with the hole in the side of the single barbed-hose shank (1/2 inch).
4. Close the upper clamp half around the barbed-hose shank and secure the clamp half and spray-nozzle body with the stainless steel screw (#12 x 1-1/4 inches); torque the stainless steel screw to 226 to 282 N·cm (20 to 25 in-lb).

Important: Do not over tighten the stainless steel screw.

Note: Ensure that the hex-head bolt (5/16 x 3/4 inch) is seated in the recess in the upper clamp half when closing the clamp.

5. Repeat steps 2 through 4 to the single barbed-hose shanks of the other hose assemblies (spray valve 5 or 6) for the center-boom section.

Installing the Turrets to the Center Boom Sections

1. Align the previously removed hex-head bolt (5/16 x 3/4 inch) of the turret through the hole in the mount and loosely secure the turret to the mount with a flange locknut (5/16 inch).

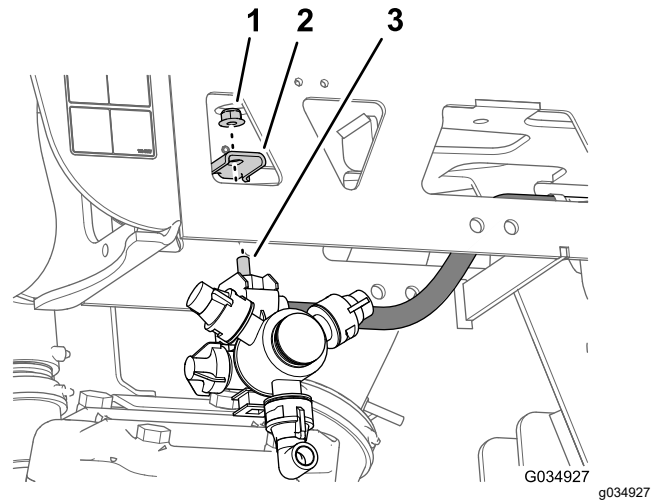

Figure 73

1. Flange locknut (5/16 inch)
 2. Turret mount (outboard)
 3. Hex-head bolt (5/16 x 3/4 inch—stainless steel)
-
2. Repeat the above step for the 3 other turrets for the center-boom section.
 3. Torque the flange locknuts to 1978 to 2542 N·cm (175 to 225 in-lb).

12

Assembling the Rear Wiring Harness to the Machine

Parts needed for this procedure:

1	Rear wire harness
3	Cable tie

Routing Wire Harness Along the Frame Tube

1. Locate the 165 cm (65 inch) branch and the 203 cm (80 inch) branch of the new electrical harness.

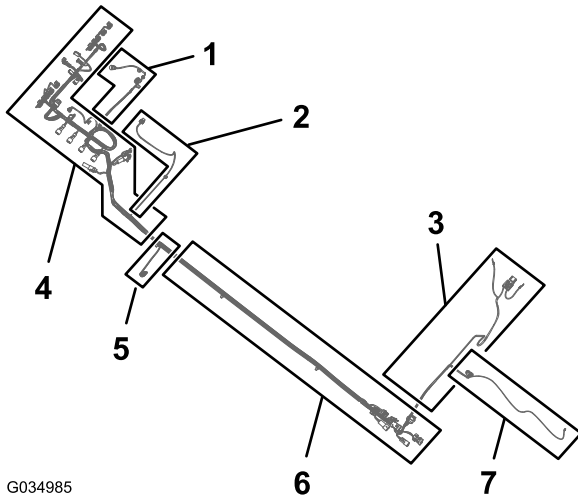

G034985

Figure 74

g034985

- | | |
|--|--|
| 1. 81 cm (32 inch) wire-harness branch— flow meter and agitation valve | 5. 33 cm(13 inch) wire-harness branch—speed sensor |
| 2. 86 cm (34 inch) wire-harness branch— spray-pump solenoid | 6. 170 cm (67 inch) wire-harness branch—front harness interface connectors |
| 3. 165 cm (65 inch) wire-harness branch—ring terminals and fuse (unmarked) | 7. 81 cm (32 inch) wire-harness branch—spray pump shutoff circuit |
| 4. 203 cm (80 inch) wire-harness branch— ASC10 , lift cylinder solenoids, nozzle-valves 1 through 10 | |

harness between the valve mount for the 10 spray valves and right support for the manifold mount.

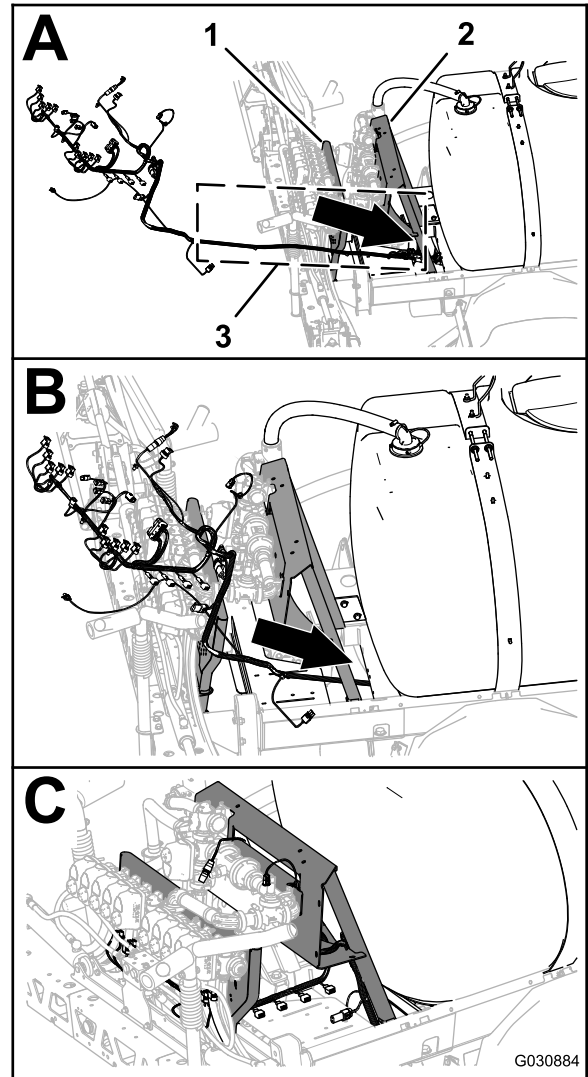

Figure 75

g030884

- | | |
|--|--|
| 1. Valve mount (10 spray valves) | 3. 165 cm (65 inch) and 203 cm (80 inch) branches (electrical harness) |
| 2. Manifold mount | |
| 3. Route the 165 cm (65 inch) branch and the 203 cm (80 inch) branch of the electrical harness forward along the right frame tube. | |

2. Route the 165 cm (65 inch) branch and the 203 cm (80 inch) branch of the new electrical

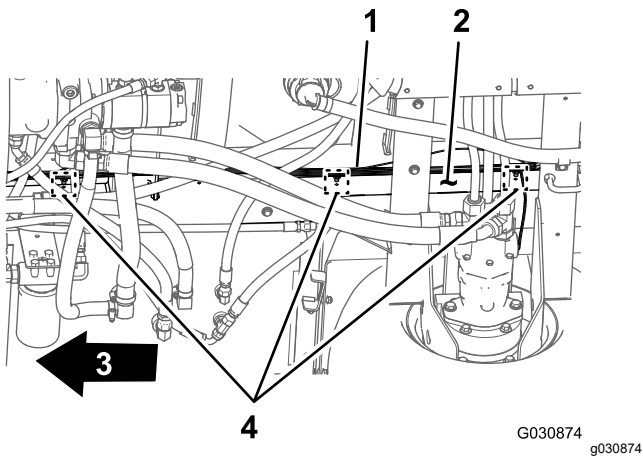

Figure 76

1. Rear wire harness—203 cm (80 inch) branch
2. Right frame tube
3. Front of the machine
4. Push-in fasteners and cable tie locations

4. Insert the push-in fasteners of the 203 cm (80 inch) branch of the rear wire harness into the holes in the right frame tube where the push-in fasteners of the old rear harness were removed; refer to step 3 in [Disconnecting the Front and Rear Wire Harnesses](#) (page 9).

Connecting the Front and Rear Wire Harnesses

Note: Use a machine hoist when connecting the front and rear wire harnesses.

1. From under the machine along the right frame tube, locate the electrical connectors for the front and rear wire harnesses of the machine.

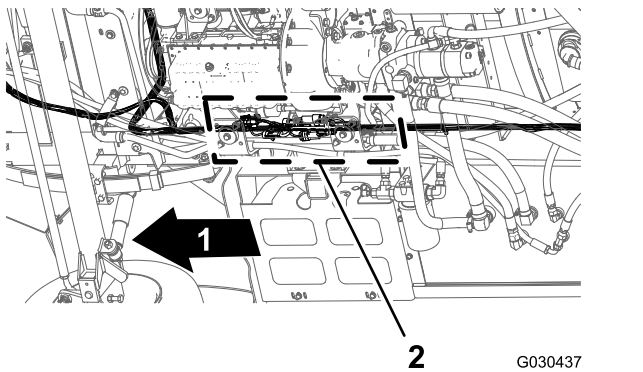

Figure 77

1. Front of the machine
2. Connector interfaces (front and rear wire harnesses)

2. Connect the 10-socket connector of the front harness for the spray-harness interconnect into the 10-pin connector of the rear harness for the spray-harness interconnect ([Figure 78](#)).

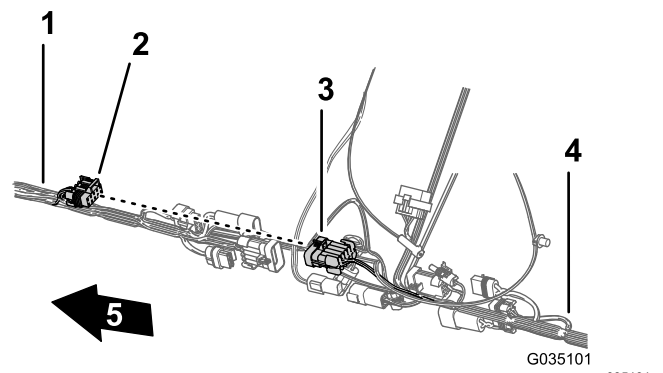

Figure 78

1. Front wire harness
2. 10-socket connector—spray-harness interconnect (front harness)
3. 10-pin connector—spray-harness interconnect (rear harness)
4. Rear wire harness
5. Front of the machine

3. Connect the 8-pin connector of the front harness for the spray-harness interconnect into the 8-socket connector of the rear harness for the rate switch.

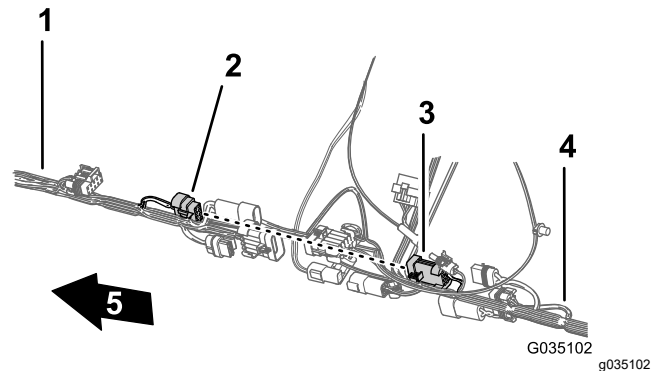

Figure 79

1. Front wire harness
2. 8-pin connector—spray-harness interconnect (front harness)
3. 8-socket connector—rate switch (rear harness)
4. Rear wire harness
5. Front of the machine

4. Connect the 2-pin connector of the front harness for the rinse pump into the 2-socket connector of the rear harness for the rinse pump.

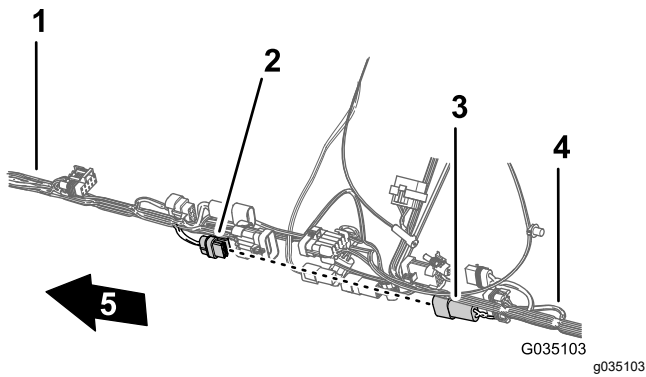

Figure 80

- | | |
|-----------------------------|-------------------------|
| 1. Front wire harness | 4. Rear wire harness |
| 2. 2-socket connector—rinse | 5. Front of the machine |
| 3. 2-pin connector—rinse | |
| | |

5. Connect the 2-pin connector of the front harness for the hose-reel power into the 2-socket connector of the rear harness for the hose-reel power.

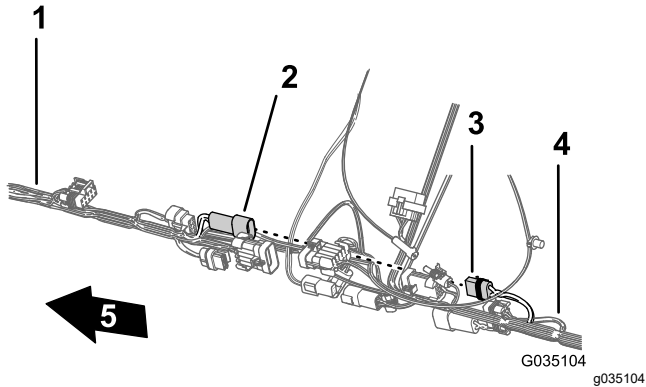

Figure 81

- | | |
|----------------------------|-------------------------|
| 1. Front wire harness | 4. Rear wire harness |
| 2. 2-pin connector—hose | 5. Front of the machine |
| 3. 2-socket connector—hose | |
| | |

6. Connect the 10-pin connector of the front harness for the spray-harness interconnect into the 10-socket connector of the rear harness for the spray-harness interconnect.

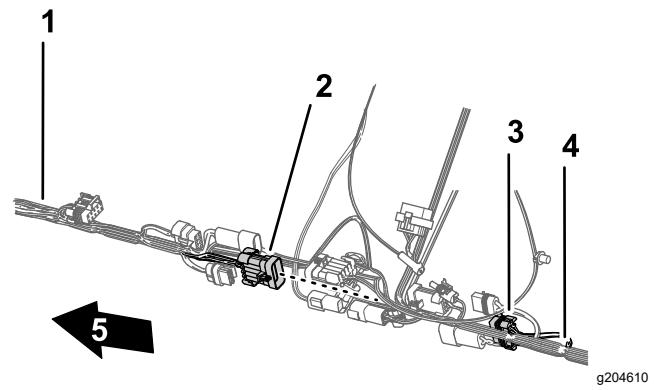

Figure 82

- | | |
|--------------------------------------|-------------------------|
| 1. Front wire harness | 4. Rear wire harness |
| 2. 10-pin connector—spray-harness | 5. Front of the machine |
| interconnect (front harness) | |
| 3. 10-socket connector—spray-harness | |
| interconnect (rear harness) | |

7. To ease connecting the navigation-electrical and data harnesses, ensure that the 1-socket connector of the rear-wire harness and the 4-socket connector of the rear-wire harness aligns to the top of the harness.

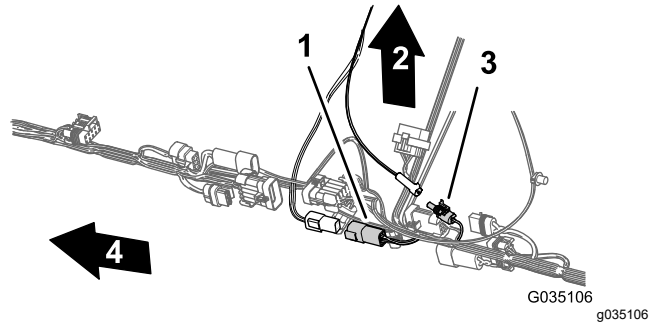
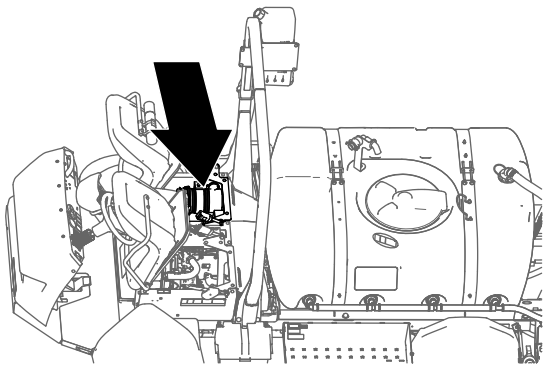

Figure 83

- | | |
|---|---|
| 1. 4-socket connector (rear-wire harness) | 3. 1-socket connector (rear-wire harness) |
| 2. Top of the machine | 4. Front of the machine |

8. Secure the pump-interrupt relay of the rear-wire harness to the right support for the seat-support angle.

Routing the Pressure Sense Tube for the Dash Gauge along the Rear Wire Harness



g191268

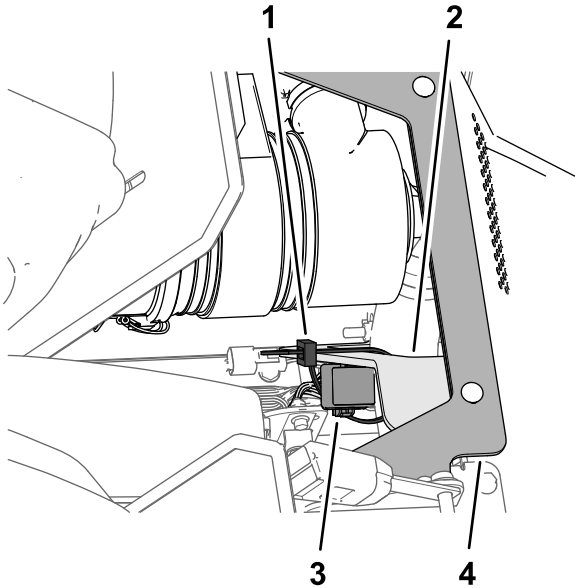

g191269

Figure 84

- | | |
|------------------|-------------------------|
| 1. Cable tie | 3. Pump-interrupt relay |
| 2. Right support | 4. Seat-support angle |

1. Route the pressure sense tube for the dash gauge along the rear wire harness of the machine.

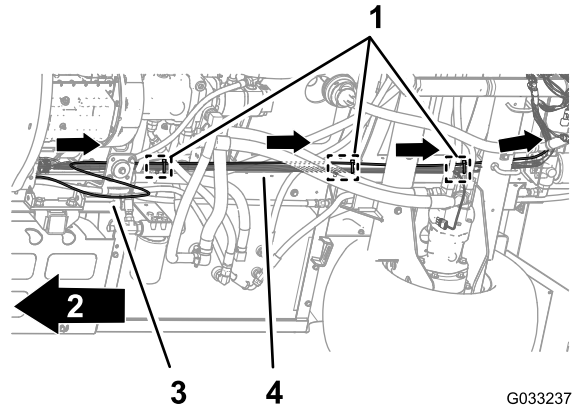

G033237

g033237

Figure 85

- | | |
|---|----------------------------------|
| 1. Cable ties (3 push-in fasteners—chassis anchor points) | 3. Pressure sense tube fasteners |
| 2. Front of the machine | 4. Rear wire harness |

2. Secure the pressure-sense tube to the rear wire harness with 3 cable ties adjacent to the 3 push-in fasteners at the chassis anchor points for the rear wire harness.

Important: Do not pinch or collapse the pressure sense tube; tighten the cable ties only enough to support the tube.

13

Installing the Engine Control Module and Mounting Bracket

No Parts Required

Procedure

1. Align the holes in the mounting bracket for the engine-control module with the hole in the support bracket of the engine and accessory case of the engine.

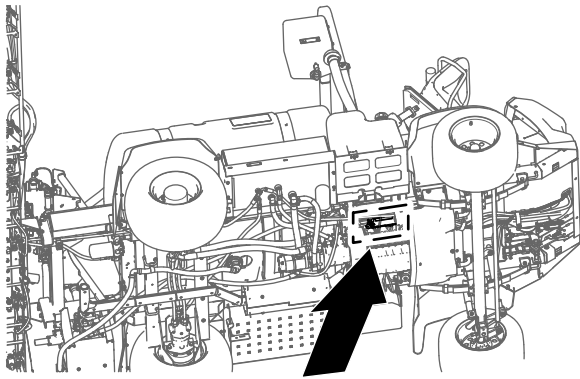

g189642

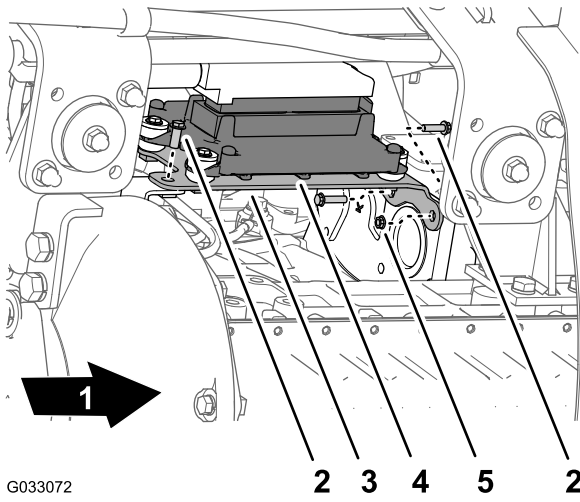

G033072

g033072

Figure 86

- | | |
|-------------------------|--------------------------|
| 1. Front of the machine | 4. Engine-control module |
| 2. Flange head bolt | 5. Flange nut |
| 3. Mounting bracket | |

2. Assemble the mounting bracket to the engine with the 3 flange head bolts and 1 flange nut that you removed in step 1 of 3 [Removing the](#)

Engine Control Module and Mounting Bracket (page 8); tighten the bolts and nuts by hand.

14

Installing the Undercarriage Shroud

No Parts Required

Procedure

1. Align the undercarriage shroud to the bottom chassis of the machine.

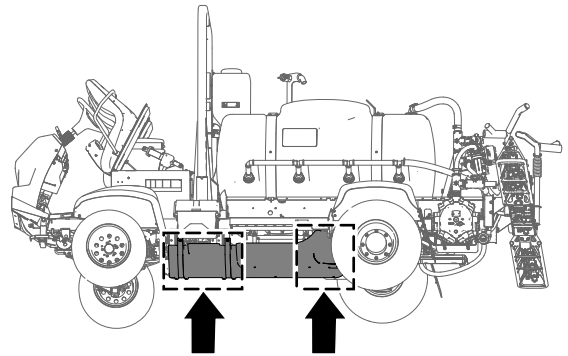

g189584

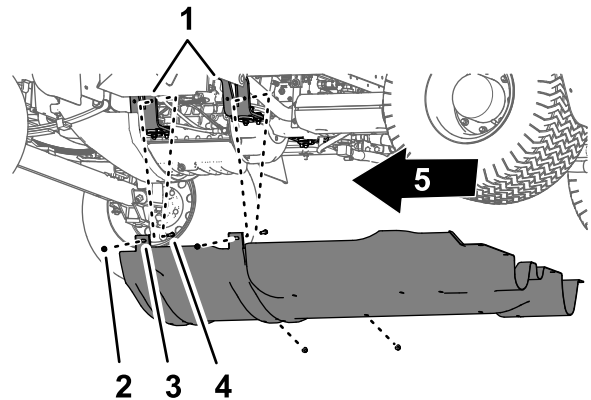

g189583

Figure 87

- | | |
|---------------------------|--------------------------------|
| 1. Engine mounts | 4. Flange locknuts (5/16 inch) |
| 2. Bolt—shown for clarity | 5. Front of the machine |
| 3. Undercarriage shroud | |

2. Slip the forward mounting flanges of the undercarriage shroud over the bolts and carriage bolt at the engine-mount brackets of the machine.
3. Assemble the undercarriage shroud to the engine-mount brackets and bolts with the 4

flange locknuts (5/16 inch) that you removed in step 2 of [2 Removing the Undercarriage Shroud](#) (page 7).

- Align the holes in the rear part of the undercarriage shroud with the holes in the chassis.

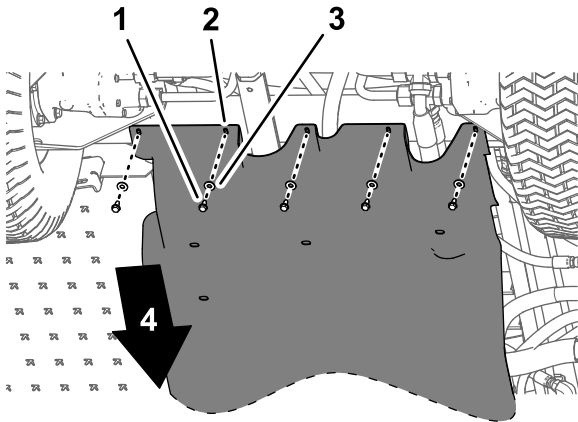

Figure 88

2017 machine shown; 2016 machines are similar

- | | |
|--|-------------------------|
| 1. Flange-head bolts (5/16 x 7/8 inch) | 3. Washers (5/16 inch) |
| 2. Undercarriage shroud | 4. Front of the machine |

- Assemble the rear part of the undercarriage shroud to the chassis with the hardware that you removed in step 1 of [2 Removing the Undercarriage Shroud](#) (page 7) as follows:

- **2016 machines**—7 flange-head bolts (5/16 x 7/8 inch) and 7 washers (5/16 inch)
- **2017 and later machines**—5 flange-head bolts (5/16 x 7/8 inch) and 5 washers (5/16 inch)

- Torque the nuts and bolts to 1129 to 1582 N·cm (100 to 140 in·lb).

15

Connecting the Rear Wire Harness

Parts needed for this procedure:

3	Cable tie
---	-----------

Routing the Wire Harness at the Manifold Mount

- Route the 203 cm (80 inch) branch of the wire harness inboard of the support strut for the valve mount and rearward toward the 10-valve mount.

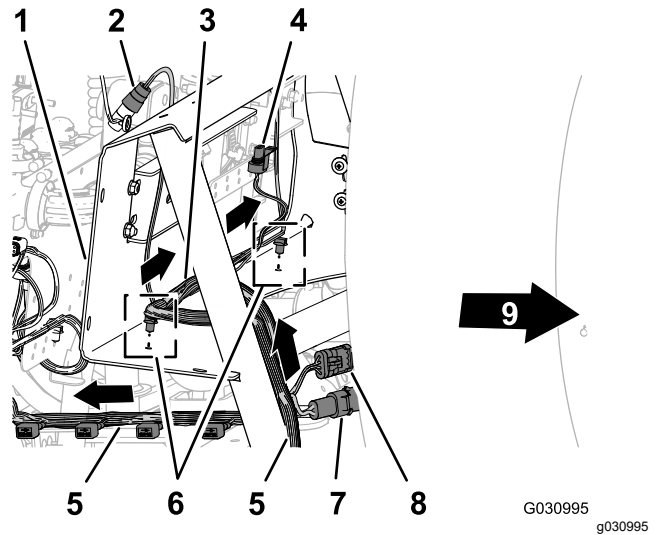

Figure 89

- | | |
|---|--------------------------------------|
| 1. Manifold mount | 6. Push-in fasteners |
| 2. 3-socket connector (flow meter) | 7. 2-pin connector (hose reel power) |
| 3. 81 cm (32 inch) wire harness branch—flow meter and agitation valve | 8. 3-socket connector (hose reel) |
| 4. Electrical connector (Agitation valve) | 9. Front of the machine |
| 5. 203 cm (80 inch) wire harness branch—ASC10, lift cylinder solenoids, Section valves 1 through 10 | |

- Route the 81 cm (32 inch) wire-harness branch for the flow meter and agitation valve across the front of the manifold mount.
- Insert the push-in fasteners of the 81 cm (32 inch) wire-harness branch into the holes in the lower flange of the manifold mount.

Routing the Wire Harness at the 10-Valve Mount

1. Route the 203 cm (80 inch) wire-harness branch across the back of the 10-valve mount with the 10 connectors for the Section valves rearward and below the valves.

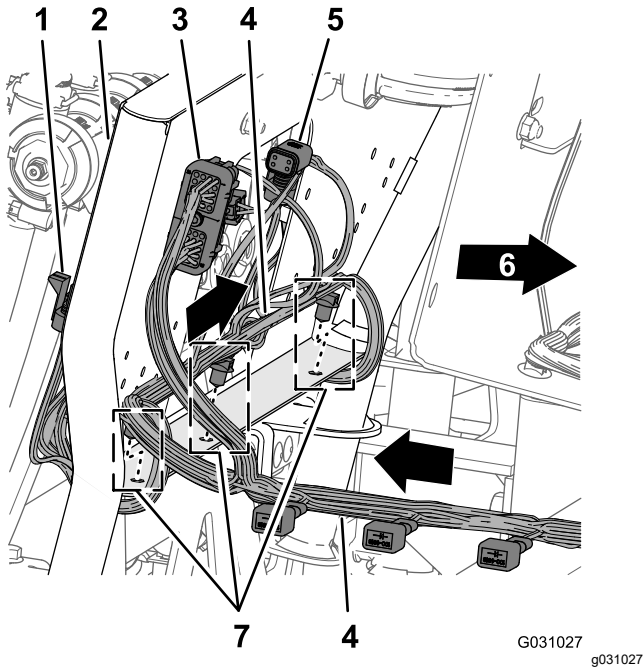

Figure 90

- | | |
|--|---------------------------------------|
| 1. 3-socket connector (nozzle valve position 10) | 5. 4-socket connector (to the ASC 10) |
| 2. 10-valve mount | 6. Front of the machine |
| 3. 40-socket connector (ASC 10) | 7. Push-in fasteners |
| 4. 203 cm (80 inch) wire harness branch—ASC10, lift cylinder solenoids, nozzle valves 1 through 10 | |

2. Insert the push-in fasteners of the 203 cm (80 inch) wire-harness branch into the holes in the lower flange of the 10-valve mount.

Routing the Wire Harness for the Spray Pump

1. Route the 86 cm (34 inch) wire harness branch for the spray-pump solenoid across the top of the spray frame channel and down toward the spray pump solenoid.

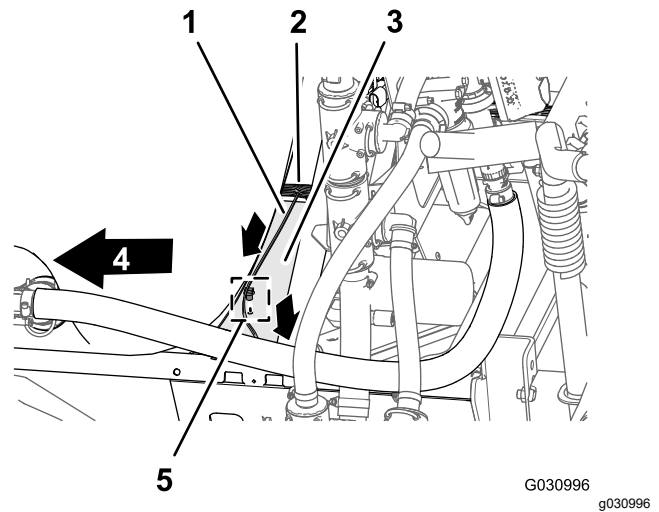

Figure 91

- | | |
|--|-------------------------|
| 1. 86 cm (34 inch) wire harness branch—spray-pump solenoid | 4. Front of the machine |
| 2. 203 cm (80 inch) wire harness branch—ASC10, lift cylinder solenoids, nozzle valves 1 through 10 | 5. Push-in fastener |
| 3. Channel (sprayer frame) | |

2. Insert the push-in fastener of the 86 cm (34 inch) wire harness branch into the hole in the sprayer frame channel.

Connecting the Wire Harness to the Manifold Mount Components

1. Route the connectors of the 203 cm (80 inch) wire harness branch labeled **Flow Meter** and labeled **Pressure Transducer** rearward of the manifold mount.

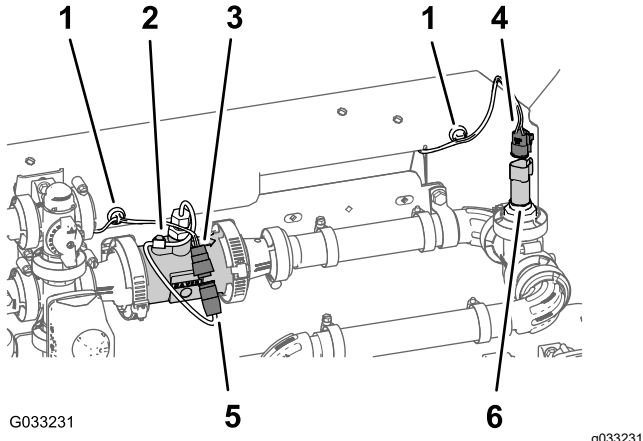

Figure 92

- | | |
|--|---|
| 1. Magnetic harness anchor | 4. 3-socket connector (rear wire harness—labeled Pressure Transducer) |
| 2. Flow meter | 5. 3-pin connector (flow-meter harness) |
| 3. 3-socket connector (rear wire harness—labeled Flow Meter) | 6. 3-pin connector (pressure transducer) |

2. Connect the 3-socket connector of the 203 cm (80 inch) wire-harness branch for the flow meter (not labeled) into the 3-pin connector of the harness of the flow meter.
3. Connect the 3-socket connector of the 203 cm (80 inch) wire-harness branch for the labeled **Pressure Transducer** into the 3-pin connector of the pressure transducer.
4. Adhere the magnet-harness anchors for the flow meter and the pressure transducer onto the surface of the manifold mount.
5. Route the 3-pin connector for the harness of the agitation valve forward of the manifold mount.

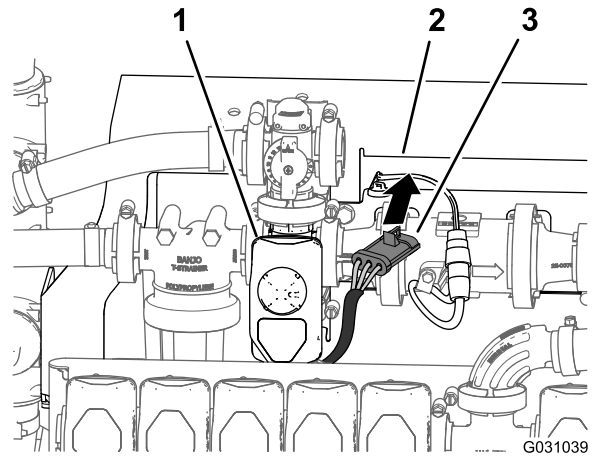

Figure 93

- | | |
|--------------------|---|
| 1. Agitation valve | 3. 3-socket connector (agitation-valve harness) |
| 2. Manifold mount | |

6. Connect the 3-pin connector for the harness of the agitation valve into the 3-socket connector of the 203 cm (80 inch) wire-harness branch labeled **Agitation Valve**.

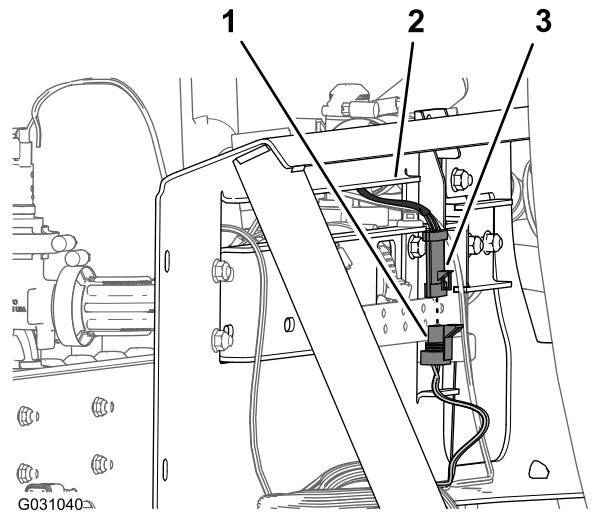

Figure 94

- | | |
|--|---|
| 1. 3-pin connector (rear wire harness—labeled Agitation Valve) | 3. 3-socket connector (agitation-valve harness) |
| 2. Manifold mount | |

Connecting the Wire Harness to the Solenoids for the Lift-Cylinder Manifold

1. At the bottom of the lift-cylinder manifold, connect the 2-socket connector of the rear wire harness labeled **Enable Solenoid** into the 2-pin connector for the enable solenoid.

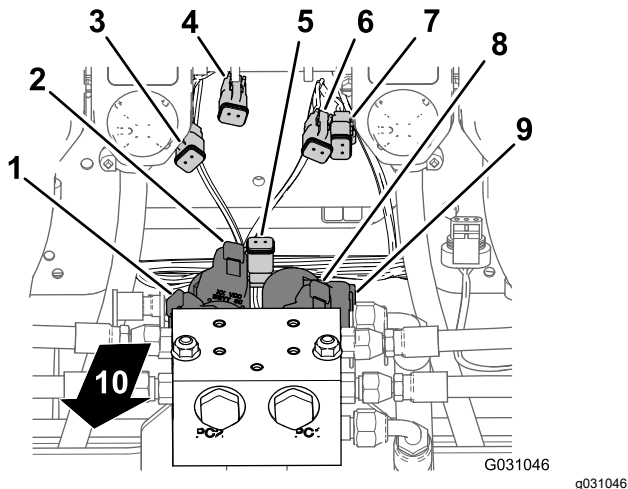

Figure 95

- | | |
|--|---|
| 1. 2-pin connector—left down solenoid (lift-cylinder manifold) | 6. 2-socket connector—Right Up (main-harness connector) |
| 2. 2-pin connector—left up solenoid (lift-cylinder manifold) | 7. 2-socket connector—Right Up (main-harness connector) |
| 3. 2-socket connector—Left Down (main-harness connector) | 8. 2-pin connector—right up solenoid (lift-cylinder manifold) |
| 4. 2-socket connector—Left Up (main-harness connector) | 9. 2-pin connector—right down solenoid (lift-cylinder manifold) |
| 5. 2-socket connector—Enable Solenoid (main-harness connector) | 10. Back of the machine |

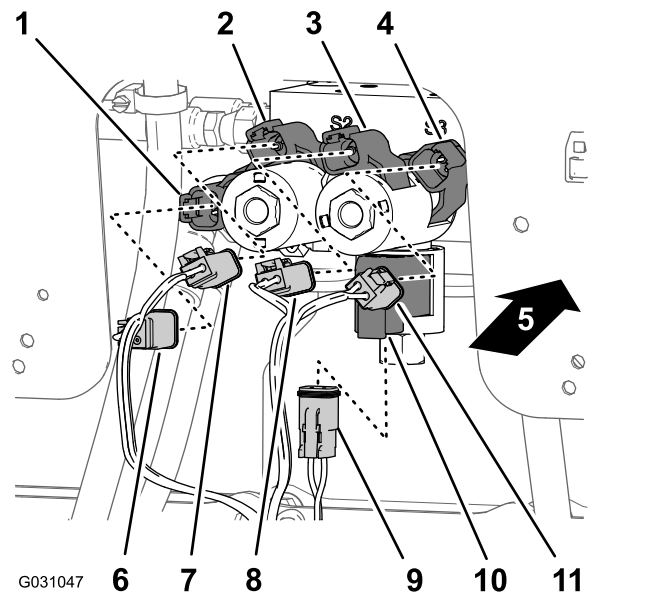

Figure 96

- | | |
|---|--|
| 1. 2-pin connector—right down solenoid (lift-cylinder manifold) | 7. 2-socket connector—Right Up (main-harness connector) |
| 2. 2-pin connector—right up solenoid (lift-cylinder manifold) | 8. 2-socket connector—Left Up (main-harness connector) |
| 3. 2-pin connector—left up solenoid (lift-cylinder manifold) | 9. 2-socket connector—Enable Solenoid (main-harness connector) |
| 4. 2-pin connector—left down solenoid (lift-cylinder manifold) | 10. 2-pin connector—enable solenoid (lift-cylinder manifold) |
| 5. Back of the machine | 11. 2-socket connector—Left Down (main-harness connector) |
| 6. 2-socket connector—Right Down (main-harness connector) | |

2. At the lower right solenoid, connect the 2-socket connector of the rear wire harness labeled **Right Down** into the 2-pin connector for the right down solenoid.
3. At the upper right solenoid, connect the 2-socket connector of the rear wire harness labeled **Right Up** into the 2-pin connector for the right up solenoid.
4. At the lower left solenoid, connect the 2-socket connector of the rear wire harness labeled **Left Down** into the 2-pin connector for the left down solenoid.
5. At the upper left solenoid, connect the 2-socket connector of the rear wire harness labeled **Left Up** into the 2-pin connector for the left up solenoid.

Connecting the Wire Harness to the Spray Valves

1. Route the 3-socket connectors of the 203 cm (80 inch) wire-harness branch with labels **Nozzle Valve 1** through **Nozzle Valve 5** rearward of the 10-valve mount and below nozzle valves 1 through 5.

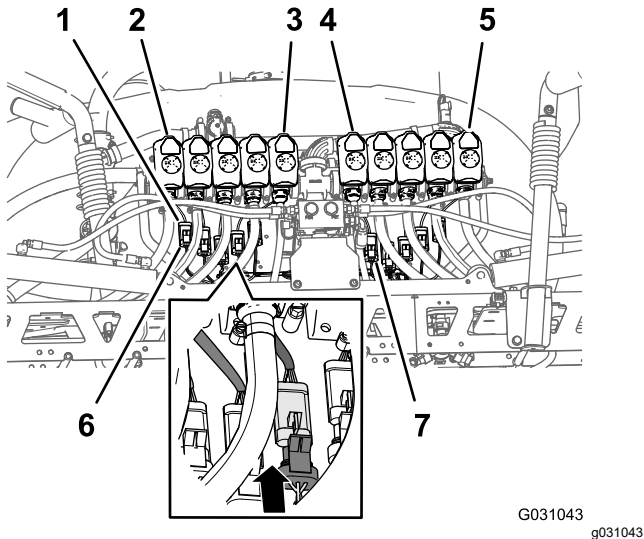

Figure 97

- | | |
|---|--|
| 1. 3-pin connector (nozzle-valve harness) | 5. Nozzle-valve 10 |
| 2. Nozzle-valve 1 | 6. 3-pin socket connector (rear wire harness—labeled Nozzle 1) |
| 3. Nozzle-valve 5 | 7. 3-pin socket connector (rear wire harness—labeled Nozzle 6) |
| 4. Nozzle-valve 6 | |

2. Route the 3-socket connectors of the 203 cm (80 inch) wire-harness branch with labels **Nozzle Valve 6** through **Nozzle Valve 10** rearward of the 10-valve mount and below nozzle-valves 6 through 10.

3. Connect the 3-pin socket connector of the rear wire harness labeled **Nozzle 1** to the 3-pin connector of the harness for nozzle-valve 1.

Important: It is important that you connect each labeled 3-pin socket connector of the rear wire harness to the correct 3-pin connector at each nozzle-valve position.

4. Repeat step 3 at the nozzle-valve positions 2 through 10.

Connecting the Wire Harness to the Spray Pump and the Speed Sensor

1. At the back of the machine—inboard of the spray pump, connect the 2-socket connector labeled **Spray Pump Solenoid** of the 86 cm (34 inch) wire-harness branch into the 2-pin connector of the relay for the pump.

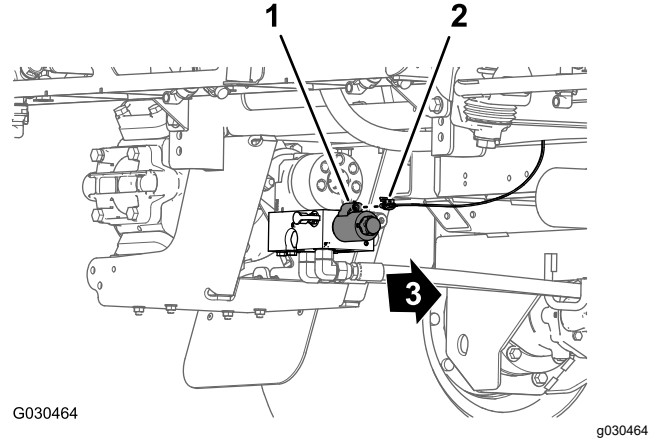

Figure 98

- | | |
|---|-------------------------|
| 1. 2-pin connector (pump relay) | 3. Front of the machine |
| 2. 2-socket connector—86 cm (34 inch) wire-harness branch | |

2. At back of the machine (between the right frame tube and the right fender) connect the 3-pin connector of the speed-sensor harness at the right hydraulic-traction motor from the 3-socket connector (unmarked) of the rear, main harness.

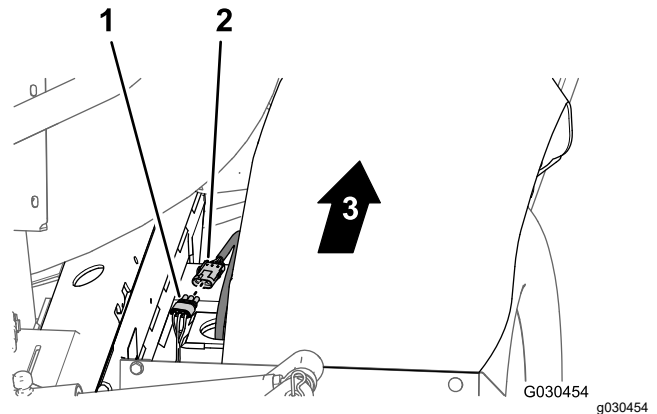

Figure 99

- | | |
|--|-------------------------|
| 1. 3-socket connector (rear, main harness) | 3. Front of the machine |
| 2. 3-pin connector (hydraulic-motor harness) | |

Routing the Wire Harness through the Engine Compartment

1. Route the 165 cm (65 inch) branch of the wire harness up and into the rear part of the engine compartment, along the right support for the engine shroud—forward of the duct that connects the air filter and the engine.

Note: You will secure the 165 cm (65 inch) branch of the rear wire harness in [Routing the Navigation-Data and Electrical Harness to the Battery](#) (page 53).

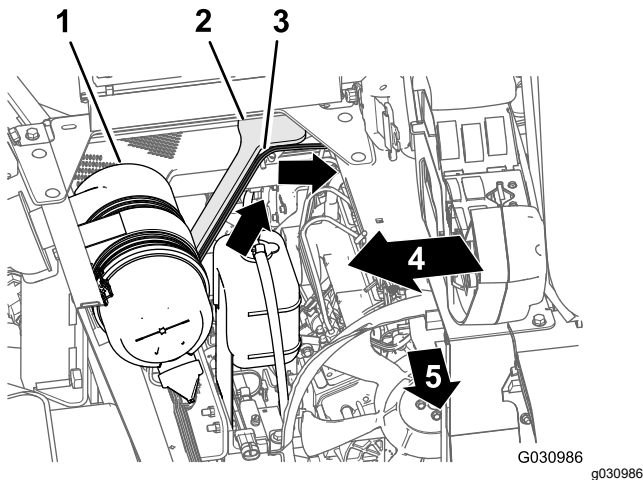

Figure 100

1. Air filter (engine)
2. Engine-shroud support (right)
3. 165 cm (65 inch) branch (rear wire harness)
4. Right side of the machine
5. Front of the machine

2. Route the 165 cm (65 inch) branch of the wire harness across the seat-box angle and down along the left support for the engine shroud.

Note: You will secure the 165 cm (65 inch) branch of the rear wire harness in [Routing the Navigation-Data and Electrical Harness to the Battery](#) (page 53).

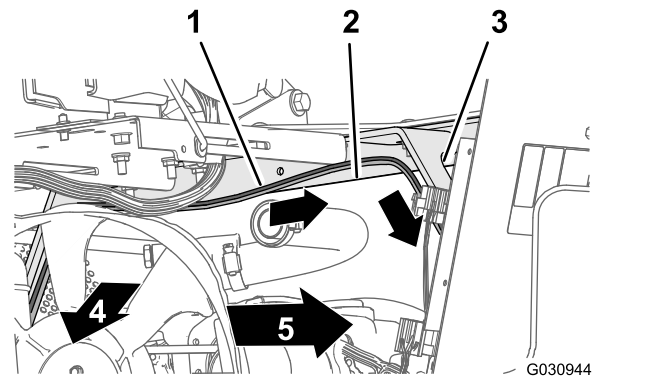

Figure 101

1. 165 cm (65 inch) branch (rear wire harness)
2. Seat-box angle
3. Engine-shroud support (left)
4. Front of the machine
5. Left side of the machine

3. Route the 165 cm (65 inch) branch of the wire harness down along the left support for the engine shroud and under the left frame tube).

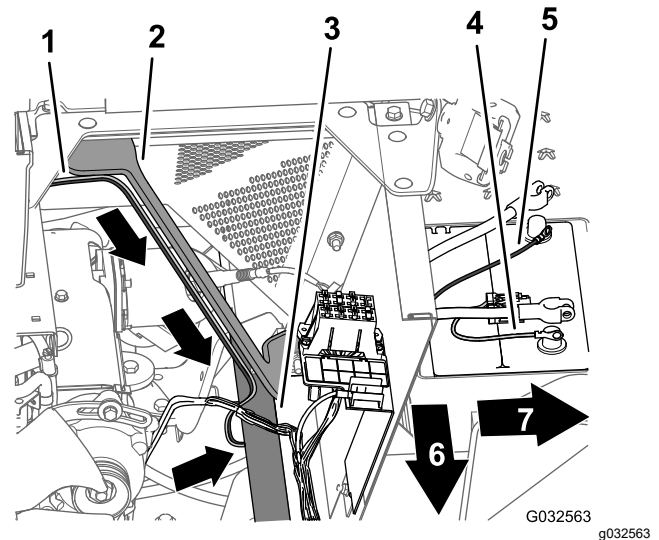

Figure 102

1. 165 cm (65 inch) branch (rear wire harness)
2. Engine-shroud support (left)
3. Left frame tube
4. Positive terminal (red wire)—165 cm (65 inch) branch (rear wire harness)
5. Negative terminal (black wire)—165 cm (65 inch) branch (rear wire harness)
6. Front of the machine
7. Left side of the machine

4. Route the 50 A fuse and the positive- and negative-ring terminals of the 165 cm (65 inch) branch of the wire harness to the top of the battery.

Note: You will complete the installation of the ring terminals in upcoming steps.

Routing the Wire Harness for the Spray Pump Shutoff Circuit

1. Rotate the driver's seat forward and place the prop rod for the seat into the detent in the console channel.
2. Remove the 5 flange-head bolts (1/4 x 3/4 inch) that secure the cover at the left side of the center console.

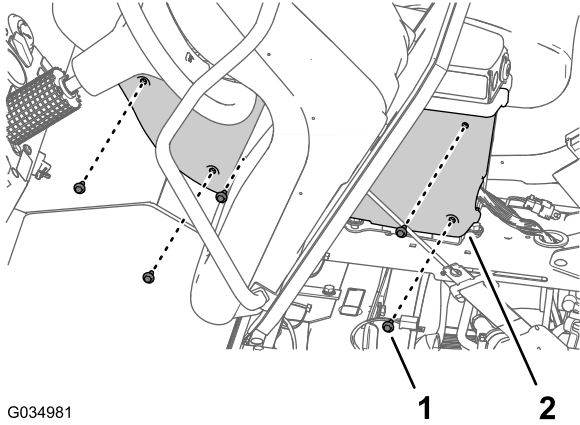

G034981

g034981

Figure 103

1. Flange-head bolt (1/4 x 3/4 inch)
2. Cover (left side—center console)

3. Remove the cover from the center console.

Note: If needed, rotate the driver's seat down when removing the cover from the center console.

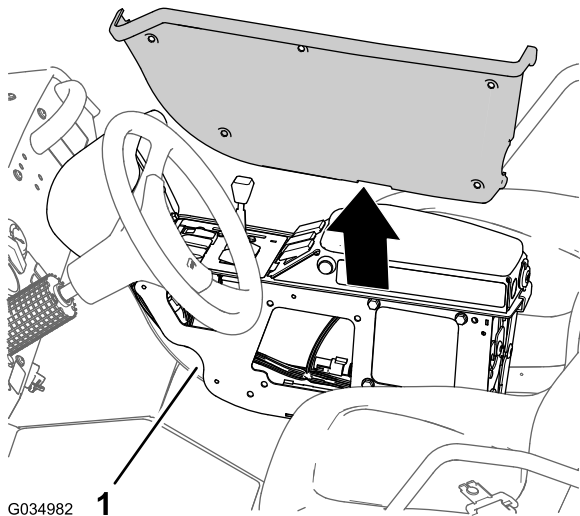

G034982

g034982

Figure 104

1. Console frame

4. Route the 81 cm (32 inch) branch of the rear-wire harness along the front wire harness and up through the grommet in the console channel.

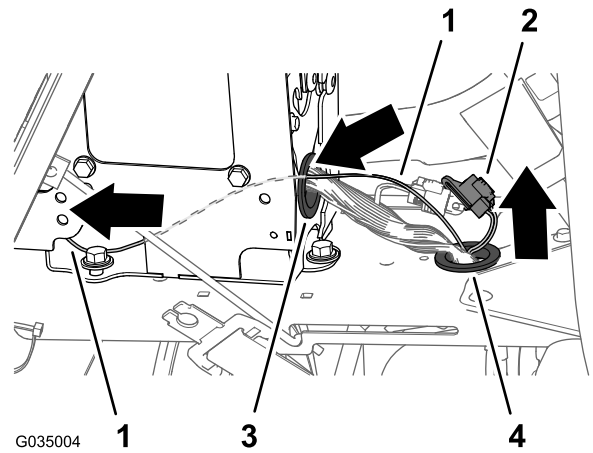

G035004

g035004

Figure 105

1. 81 cm (32 inch) wire-harness branch—spray pump shutoff circuit
2. 3-socket connector (CAN diagnostic)
3. Grommet (center console)
4. Grommet (console channel)

5. Route the 81 cm (32 inch) branch of the rear-wire harness forward along the front wire harness and through the grommet in the back of the center console.

Adding the Spray Pump Shutoff Circuit to the Spray-Pump Switch

1. Press in the latch for the 8-socket connector at the spray-pump switch, and separate the connector from the switch.

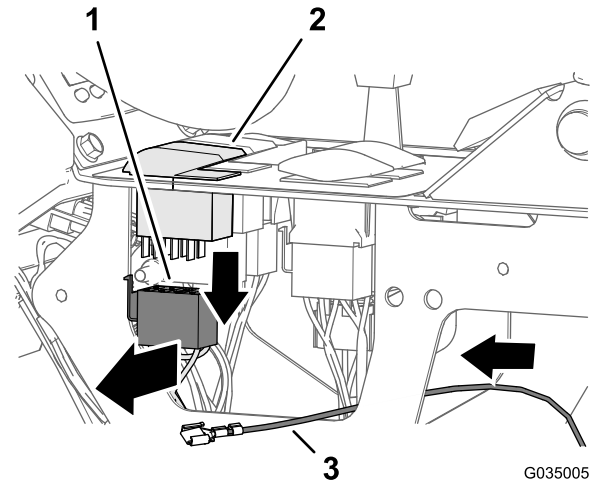

G035005

g035005

Figure 106

1. 8-socket connector (spray-pump switch)
2. Spray-pump switch
3. 81 cm (32 inch) wire-harness branch

2. Position the 8-socket connector so that you can see the back of the connector and the latch is up.

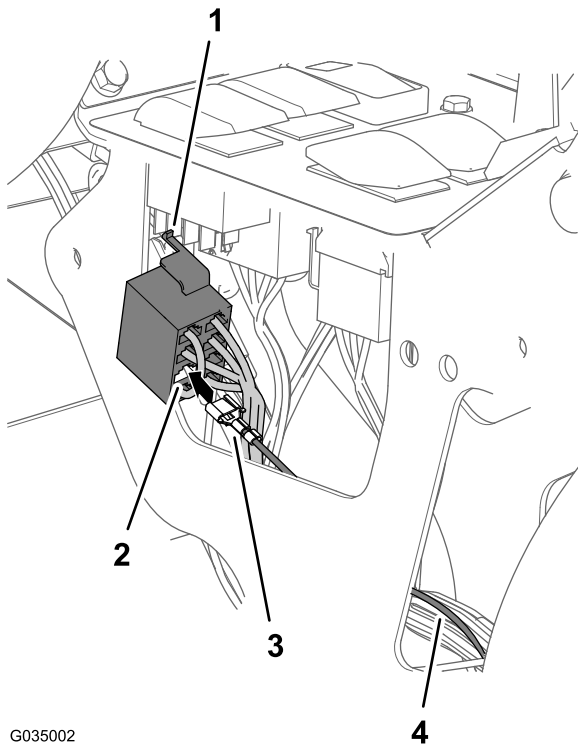

G035002

g035002

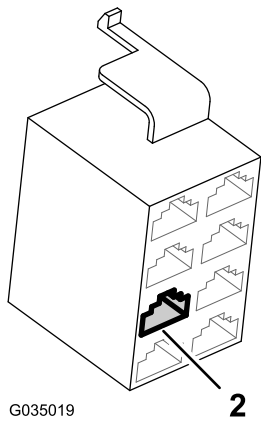

G035019

g035019

Figure 107

- | | |
|--|---|
| 1. Latch (8-socket connector) | 3. Terminal (81 cm (32 inch) wire-harness branch) |
| 2. Terminal-position #4 (8-socket connector—spray-pump switch) | 4. 81 cm (32 inch) wire-harness branch |

3. Insert the terminal at the end of the 81 cm (32 inch) branch of the rear-wire-harness into terminal position #4 of the 8-socket connector.

Note: Ensure that the latch of the terminal snaps securely into the 8-socket connector.

4. Connect the 8-socket connector if the wire harness with the 8-pin connector if the spray-pump switch.

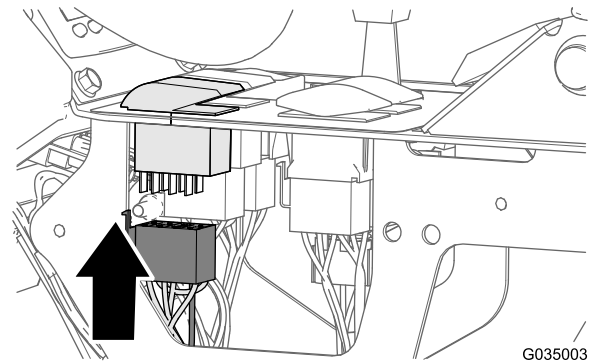

G035003

g035003

Figure 108

5. Secure the 81 cm (32 inch) branch of the rear-wire-harness to the front wire harness of the machine.

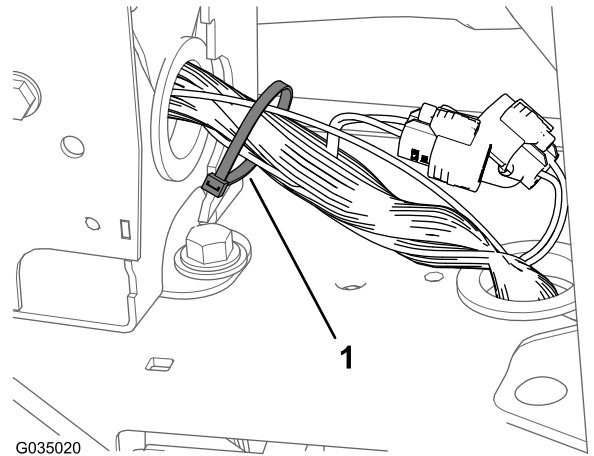

G035020

g035020

Figure 109

1. Cable tie

6. Align the cover that you removed (Figure 104) to the left side of the center console.

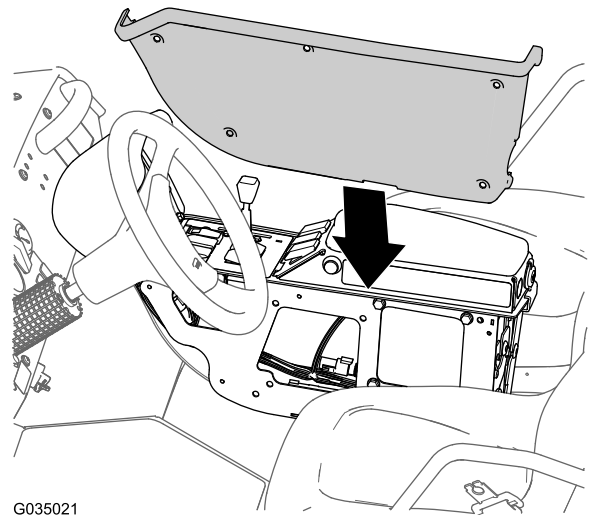

G035021

g035021

Figure 110

- Assemble the cover to the center console with the 5 flange-head bolts (1/4 x 3/4 inch) previously removed (Figure 103), and torque the bolts to 520 to 678 N·cm (46 to 60 in-lb).

17

Installing the Navigation Receiver

Parts needed for this procedure:

1	Navigation receiver
1	Receiver mount
4	Bolts (M5)
4	Lock washer
4	U-bolt
4	Flange locknut (3/8 inch)

Procedure

- Secure the receiver to the receiver mount using 4 bolts (M5) and 4 washers.

Note: Ensure that both arrows are pointing toward the front of the machine.

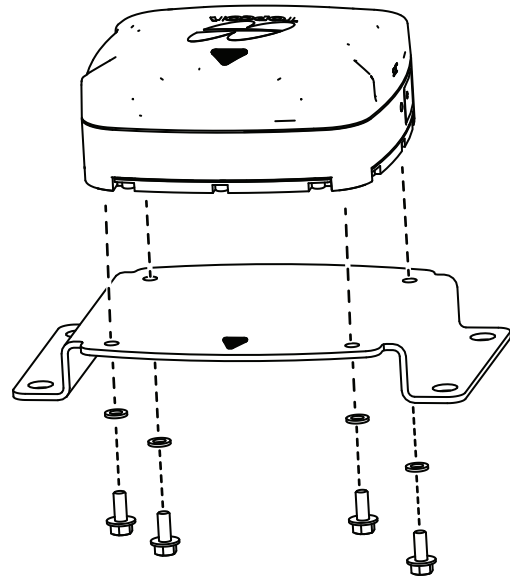

Figure 112

g506949

- Line up the arrow on the receiver mount with the middle of the roll bar and secure the assembly onto the ROPS using 4 U-bolts and 4 locknuts (3/8 inch).

16

Connecting the Pressure Sense Tube for the Dash Gauge

No Parts Required

Connecting the Pressure Sense Tube for the Dash Gauge

- Align the end of the pressure-sense tube (plastic) for the pressure gauge in the dash with the locking collar for the tube coupler.

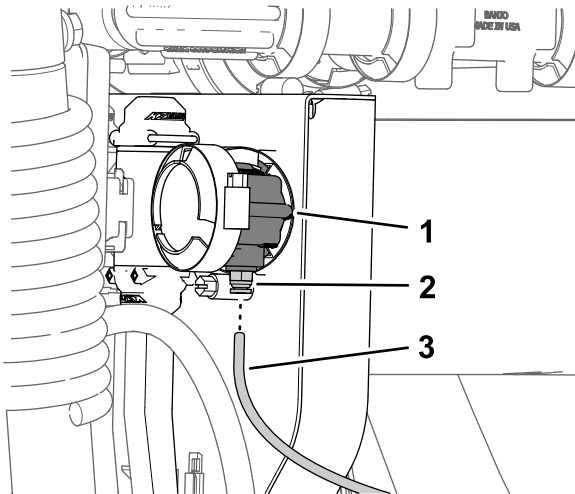

Figure 111

g189545

- | | |
|----------------------------------|--|
| 1. 90° elbow (nozzle valve 10) | 3. Pressure-sense tube (dash-pressure gauge) |
| 2. Locking collar (tube coupler) | |

- Insert the sense tube into the locking collar until the tube is fully seated.

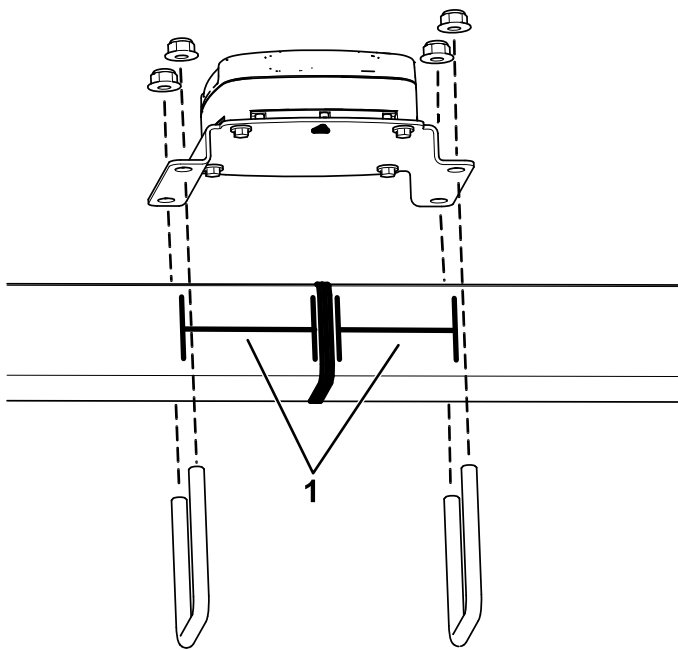

Figure 113

g412964

1. Ensure that these are the same measurements.

Installing the Modem Antennas

1. Install the modem antenna bracket to the roll bar.

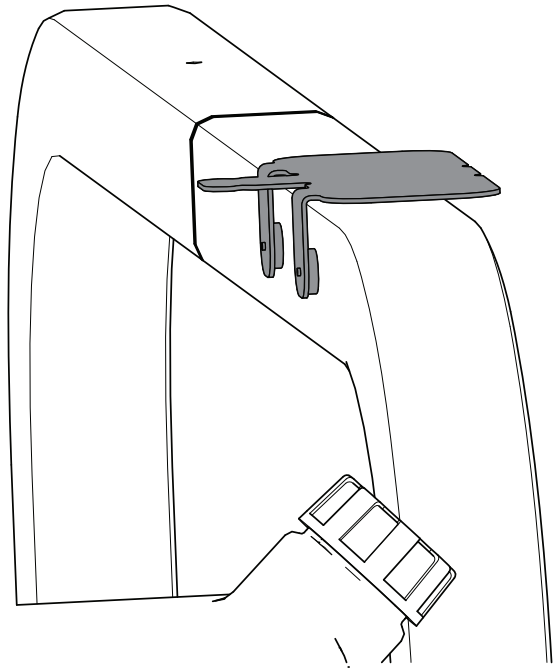

Figure 114

g413025

18

Installing the Modem Antennas to the Machine

Parts needed for this procedure:

1	Antenna mount
2	Rivet
2	Magnet
1	Modem antenna
1	High gain antenna
7	Cable ties

2. Clean any grease or oil from the antenna mount surface.
3. Remove the backing from the double sided adhesive liner and adhere the antenna to the mount.

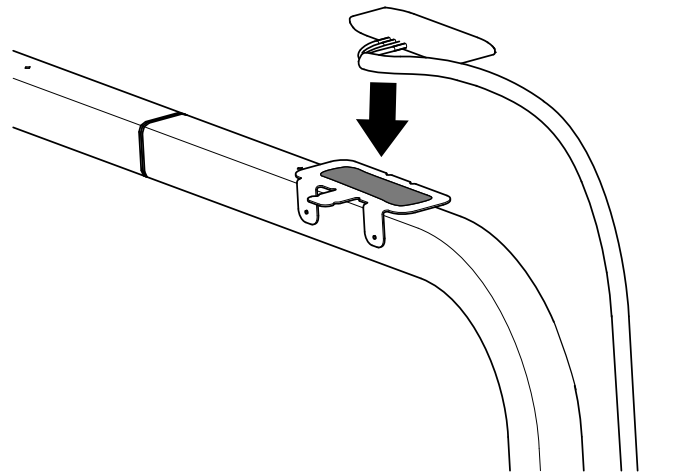

Figure 115

g420496

4. Secure the antenna and wire harness to the mount with 3 cable ties.

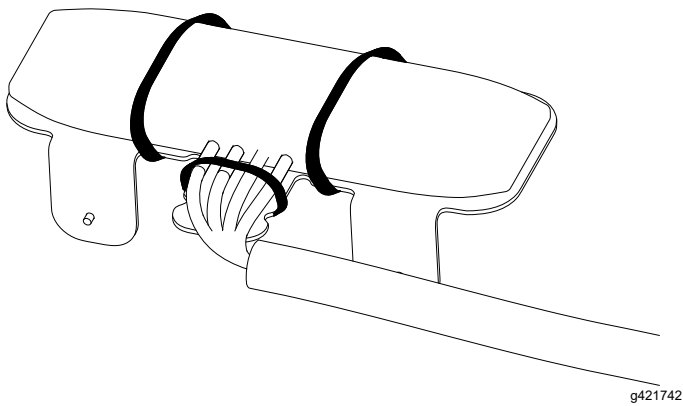

Figure 116

5. Place the high gain antenna on the roll bar.

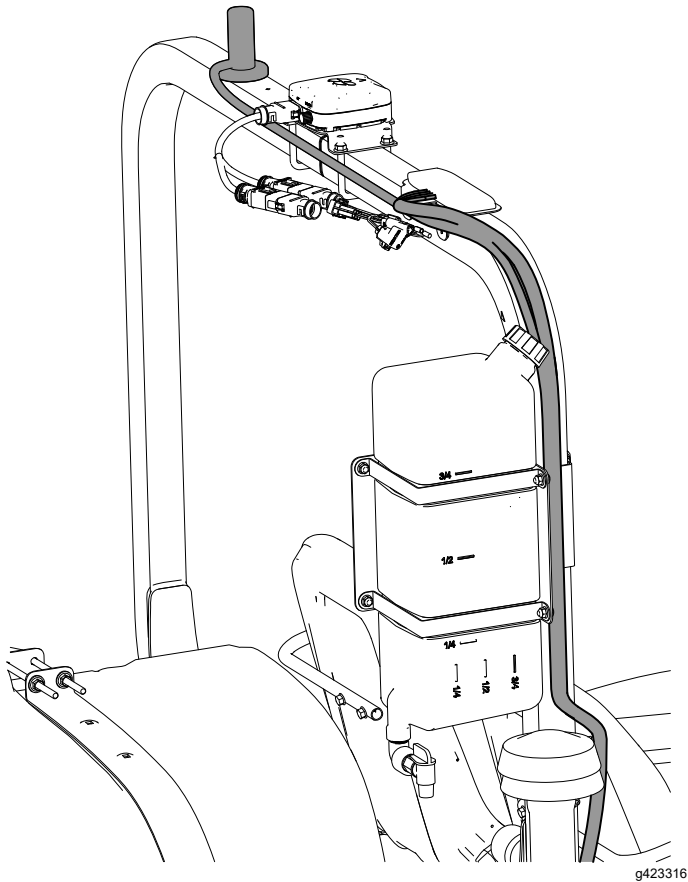

Figure 117

Routing the Modem-Antenna Harnesses

1. Route the modem-antenna harnesses to the right, along the roll bar.

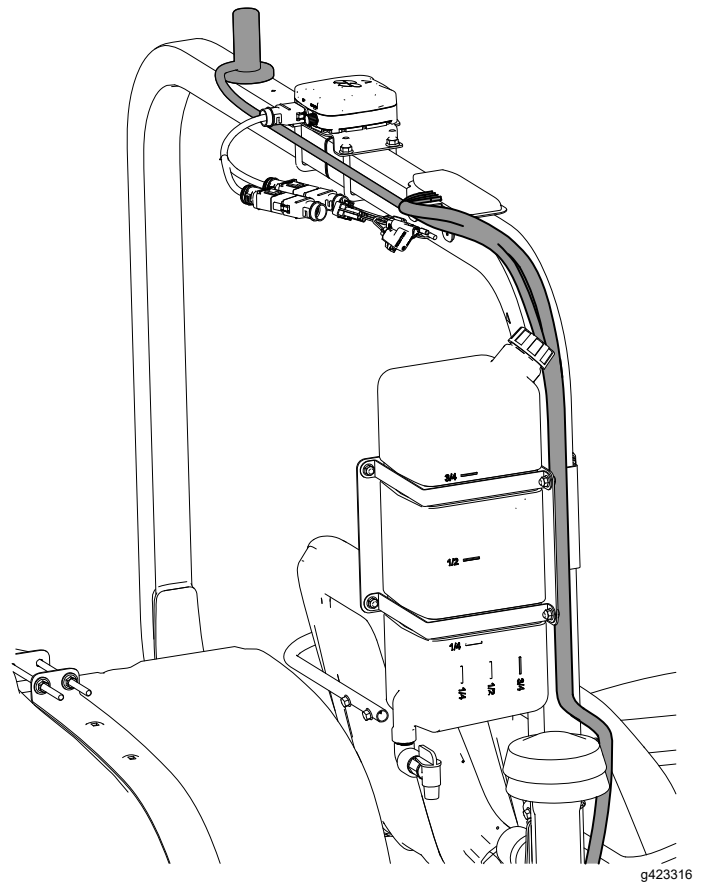

Figure 118

2. Route the harness down and forward.

19

Installing the Display

Parts needed for this procedure:

1	Display
1	Ball mount
1	Monitor arm
1	Stiffener bracket
8	Hex-head bolt (1/4-20 x 1-1/2 inches)
4	Washer (1/4 inch)
8	Locknut (1/4 inch)

Preparing the Dash Panel

1. Locate the 4 hole punchouts (1/4 inch) in the dash panel that are located to the left of the grab handle.

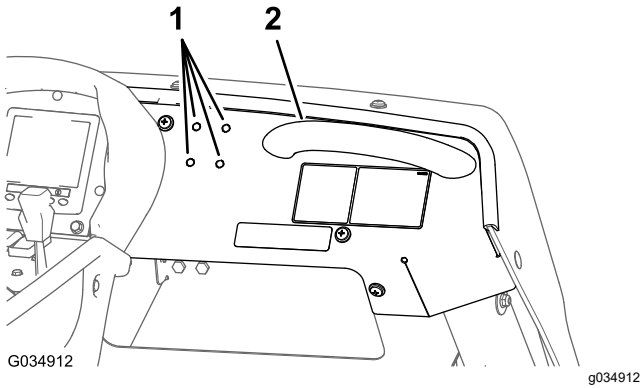

Figure 119

1. Hole punchouts (1/4 inch—dash panel)
2. Grab handle

2. Remove the 4 hole punchouts from the dash panel.

Removing the Hood Bracket

1. Remove the 2 Phillips panhead screws (1/4 x 1 inch) and locknut (1/4 inch) that secure the hood bracket to the dash.

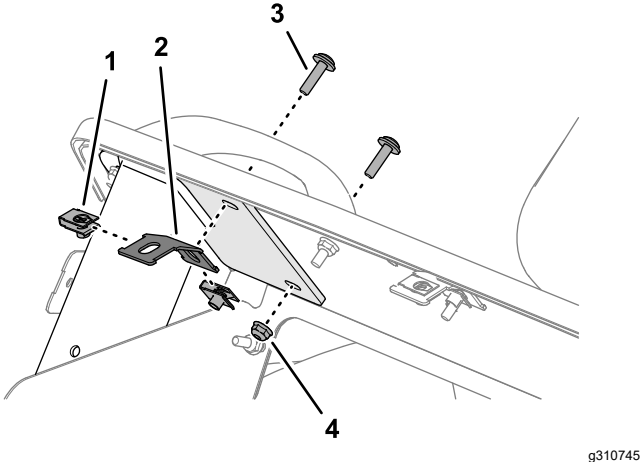

Figure 120

1. Clip nut (1/4 inch)
2. Hood bracket
3. Phillips panhead screw (1/4 x 1 inch)
4. Flange locknut (1/4 inch)

2. Remove the 2 clip nuts (1/4 inch) from the hood bracket.

Note: Retain the Phillips panhead screws, flange locknut, and clip nuts; discard the hood bracket.

Preparing the Stiffener Bracket

Assemble the previously removed clip nuts onto the stiffener bracket.

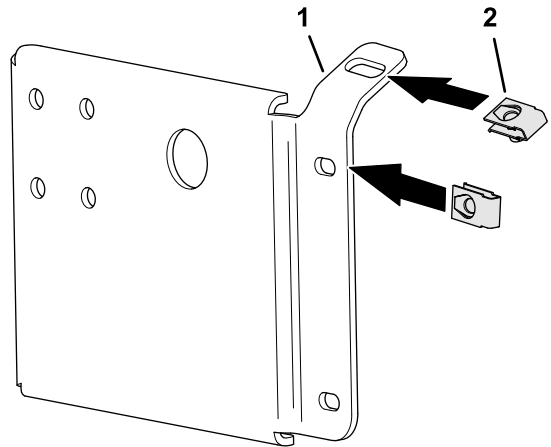

Figure 121

1. Stiffener bracket
2. Clip nut

Installing the Ball Pivot Mount Bracket

1. Assemble the bracket to the dash with the 4 hex-head bolts (1/4-20 x 1-1/2 inches), 4 washers, and secure it to the stiffener plate with 4 locknuts (1/4 inch).

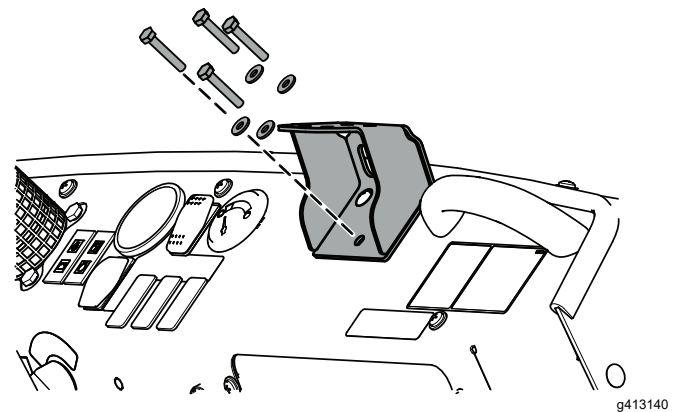

Figure 122

2. Loosely assemble stiffener plate with the 2 previously removed Phillips panhead screw (1/4 x 1 inch) and flange locknut (1/4 inch).
3. Torque the hex-head bolts, Phillips panhead screws, and locknut to 1163 to 1435 N-cm (103 to 127 in-lb)

Mounting the Display

1. Secure the ball mount onto the bracket using 4 hex-head bolts (1/4-20 x 1-1/2 inches) and 4 locknuts (1/4 inch).

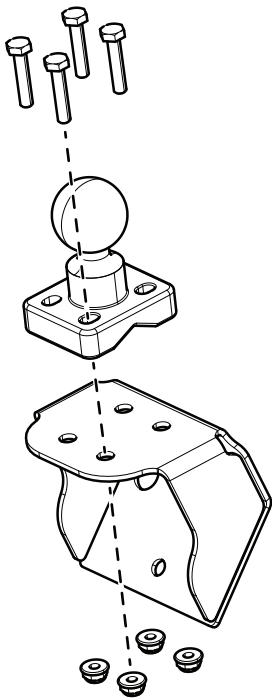

Figure 123

g506948

2. Install the display and display arm onto the ball mount.
3. Tighten the display arm knob in the desired location.

20

Installing the Wire Harnesses for the Navigation Components

Parts needed for this procedure:

1	Harness adapter
1	Data and electrical harness
8	Cable tie

Identifying the Navigation-Data and Electrical Harness

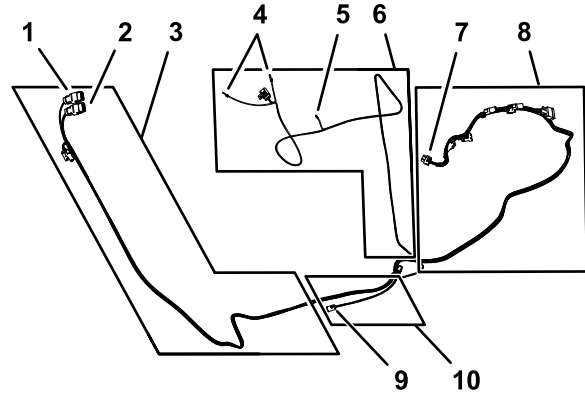

Figure 124

g310848

- | | |
|--|--|
| 1. 12-socket connector—navigation receiver <small>AGI4 A</small> CONNECTOR (GREY) | 6. 270.5 cm (106-1/2 inch) power-harness branch |
| 2. 12-socket connector—navigation receiver <small>AGI4 B</small> CONNECTOR (BLACK) | 7. 26-socket connector—(sprayer monitor) |
| 3. 302 cm (119 inches) data-harness branch (navigation receiver) | 8. 226 cm (89 inches) data-harness branch (sprayer monitor) |
| 4. Ring terminals (to battery positive and battery negative) | 9. 4-pin connector (rear harness interface—CAN 2 ASC 10 BUS) |
| 5. Socket connector (switched power) | 10. 34 cm (13-1/2 inches) data-harness branch (rear harness interface) |

Connecting the Navigation-Data and Electrical Harness to the Navigation Receiver

1. Route the 302 cm (119 inches) branch of the navigation-data and electrical harness along the right ROPS tube with the 12-socket connector **(gray)** and 12-socket connector **(black)** up toward the navigation receiver.
2. Connect the 2 connectors at the long face of the 12-socket connector of the data harness labeled **AGI 4 A KEY (GREY)** with the 2 connector slots into the adapter harness.

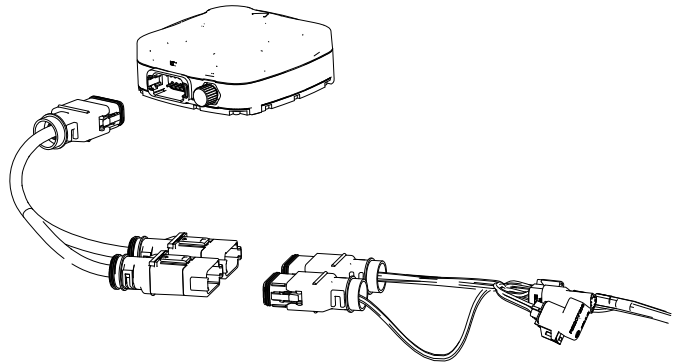

Figure 125

g420537

3. Plug the adapter harness into the receiver.

Connecting the Navigation-Data and Electrical Harness to the Rear GeoLink Harness

1. Route the 302 cm (119 inches) data-harness branch of the electrical harness with the 4-pin connector labeled CAN 2 ASC 10 BUS down to the area where the front and rear wire harness for the machine connect; refer to [Figure 83](#) in [Connecting the Front and Rear Wire Harnesses](#) (page 35).

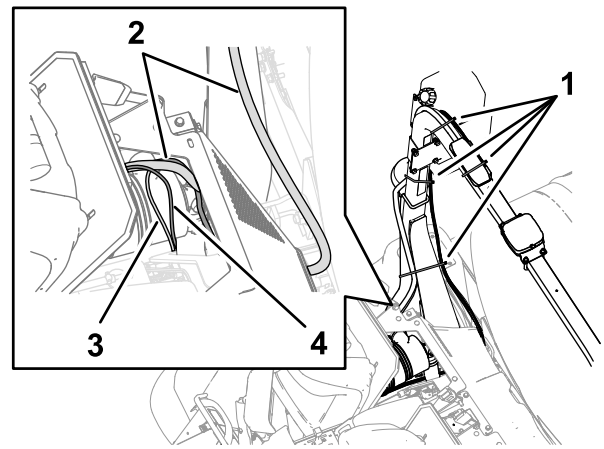

g420549

Figure 126

- | | |
|--|---|
| 1. Cable ties | 3. 34 cm (13-1/2 inches) data-harness branch (4-pin connector CAN 2 ASC 10 BUS) |
| 2. 302 cm (119 inches) data-harness branch (navigation receiver) | 4. 270.5 cm (106-1/2 inch) power-harness branch |

2. Route the 34 cm (13-1/2 inches) data-harness branch with the 4-pin connector labeled CAN 2 ASC 10 BUS down to the area where the front and rear wire harness for the machine connect; refer to [Figure 83](#) in [Connecting the Front and Rear Wire Harnesses](#) (page 35).
3. Connect the 4-pin connector of the data-harness branch labeled CAN 2 ASC 10 BUS into the 4-socket connector of the rear GeoLink harness for the CAN 2 / sprayer-controller circuit.

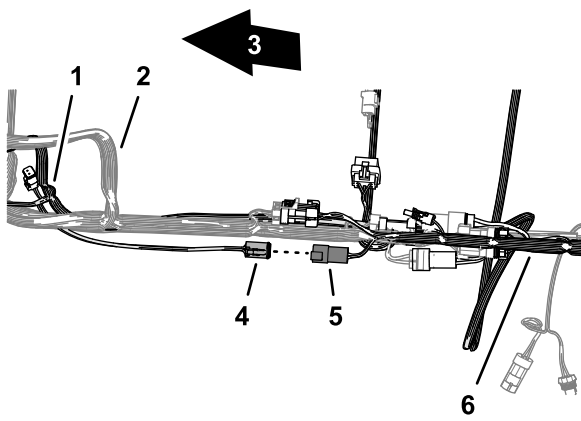

Figure 127

g310869

- | | |
|---|--|
| 1. 34 cm (13-1/2 inches) data-harness branch (navigation-data and electrical harness) | 4. 4-pin connector (labeled CAN 2 ASC 10 BUS—data-harness branch) |
| 2. Front wire harness of the machine | 5. 4-socket connector (unlabeled ASC 10 power and CAN—rear GeoLink wire harness) |
| 3. Front of the machine | 6. Rear GeoLink wire harness |

Routing the Navigation-Data and Electrical Harness to the Battery

1. Route the 270.5 cm (106-1/2 inch) power branch of the navigation-data and electrical harness across the seat-box angle and down along the left support for the engine shroud.

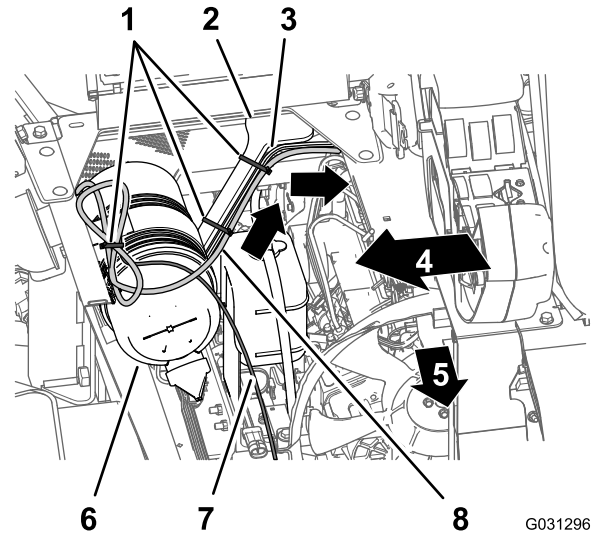

G031296

g031296

Figure 129

- | | |
|---|--|
| 1. Cable ties | 5. Front of the machine |
| 2. Engine-shroud support | 6. Air filter (engine) |
| 3. 241 cm (95 inch) branch (front machine wire harness) | 7. 226 cm (89 inches) data-harness branch (sprayer monitor) |
| 4. Right side of the machine | 8. 270.5 cm (106-1/2 inch) power branch (navigation-data and electrical harness) |

Removing the Terminating Resistor

Remove and discard the terminating resistor from the 6-socket connector of the data cable.

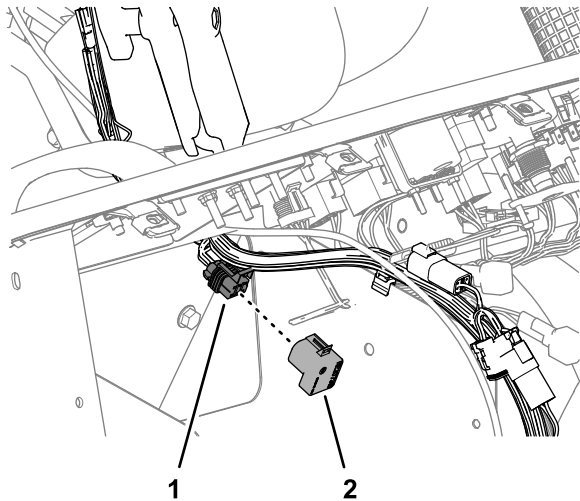

g314497

Figure 128

- | | |
|---|-------------------------|
| 1. 6-socket connector of the data cable | 2. Terminating resistor |
|---|-------------------------|

2. Secure the harness to the engine-shroud support with cable ties.
3. Route the 270.5 cm (106-1/2 inch) power branch along the left support for the engine shroud and under the left frame tube.

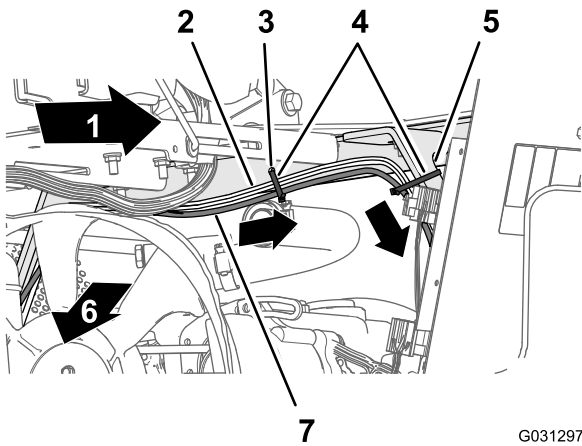

G031297
g031297

Figure 130

- | | |
|---|--|
| 1. Left side of the machine | 5. Engine-shroud support |
| 2. 241 cm (95 inch) branch (front machine wire harness) | 6. Front of the machine |
| 3. Hole in the seat-box angle) | 7. 270.5 cm (106-1/2 inch) power branch (navigation-data and electrical harness) |
| 4. Cable ties | |

4. Secure the harness to the hole in the seat-box angle and the engine-shroud support with 3 cable ties.

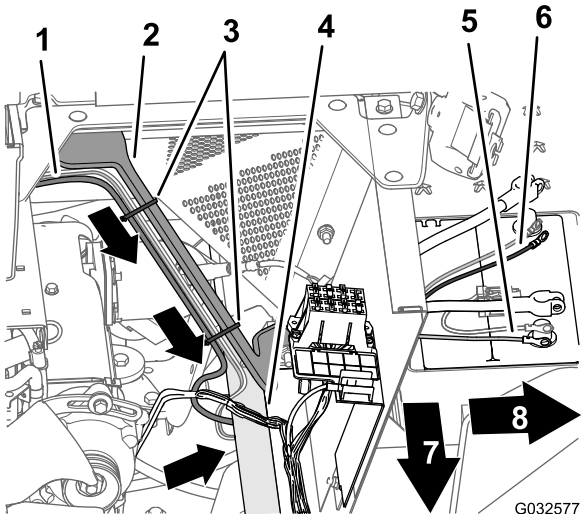

G032577
g032577

Figure 131

- | | |
|---|--|
| 1. 165 cm (65 inch) branch (front machine wire harness) | 5. Negative-ring terminal (black wire)—power branch (navigation-data and electrical harness) |
| 2. Engine-shroud support | 6. Positive-ring terminal (red wire)—power branch (navigation-data and electrical harness) |
| 3. Cable ties | 7. Front of the machine |
| 4. Left frame tube | 8. Left side of the machine |

5. Route the 10 A fuse and the positive- and negative-ring terminals of the 220 cm (86-5/8 inch) branch of the electrical-harness for the navigation system to the top of the battery.

Note: You will complete the installation of the ring terminals in upcoming steps.

Routing and Connecting the Data Cable to the Monitor

1. At the right side of the engine compartment, route the 226 cm (89 inches) data-harness branch for the monitor forward of the engine air filter and down toward the lower right corner of the radiator.

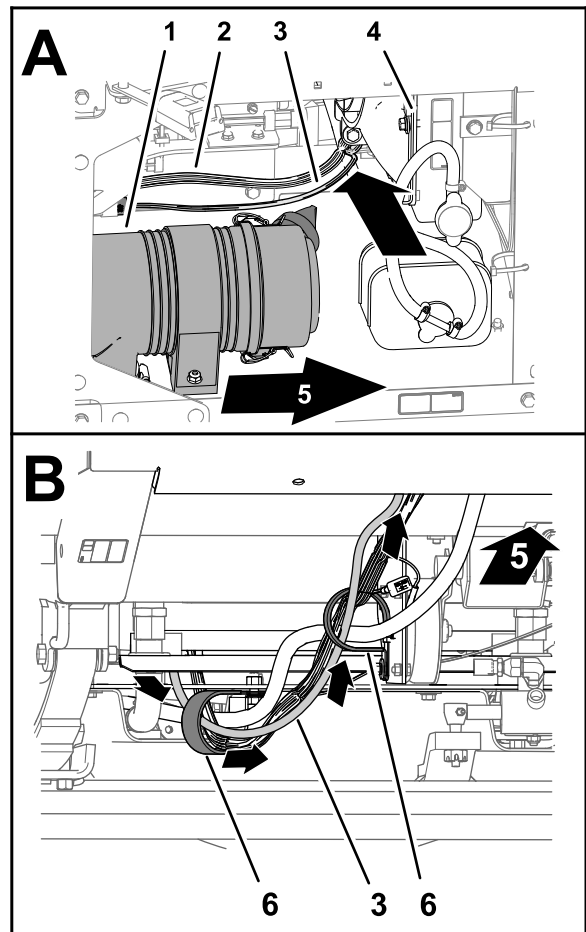

g310897

Figure 132

- | | |
|---|-------------------------|
| 1. Air filter (engine) | 4. Radiator |
| 2. Front wire harness of the machine | 5. Front of the machine |
| 3. 226 cm (89 inches) data-harness branch (sprayer monitor) | 6. R-clamps |

2. Route the harness forward and through the 2 R-clamps at the bottom of the machine and up through grommet that surrounds the hole in the floor panel.

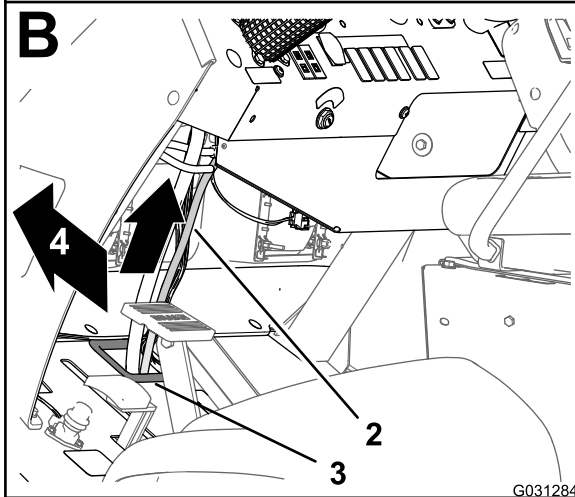
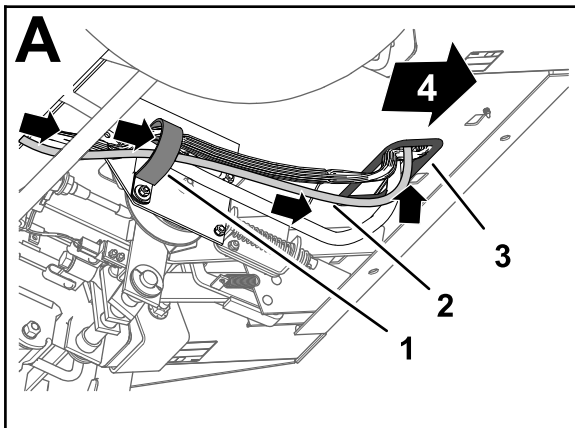

Figure 133

G031284

1. R-clamp
2. 226 cm (89 inches) data-harness branch (sprayer monitor)
3. Grommet (floor pan)
4. Front of the machine

3. Secure the harness to the front wire harness of the machine with 3 cable ties.
4. Continue to route the harness branch up and along the front wire harness of the machine and up through the grommet that surrounds the hole in the dash panel.
5. Plug the cable into the back of the monitor.

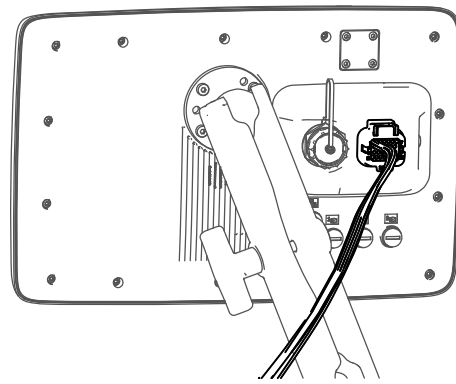

Figure 134

g422947

21

Assembling the Modem Power Harness to the Machine

Parts needed for this procedure:

1	Modem power harness—1850 mm (72-7/8 inches)—GeoLink precision spray system kit (Model 41712 or Model 41713)
5	Cable ties—GeoLink precision spray system kit (Model 41712 or Model 41713)

Routing the Modem Power Harness

1. Between the fuel tank bracket and the right, front fender, route the tab terminal (labeled SWITCHED) and 2 ring terminal (labeled BATTERY and GROUND) of the modem power harness under the frame of the machine.

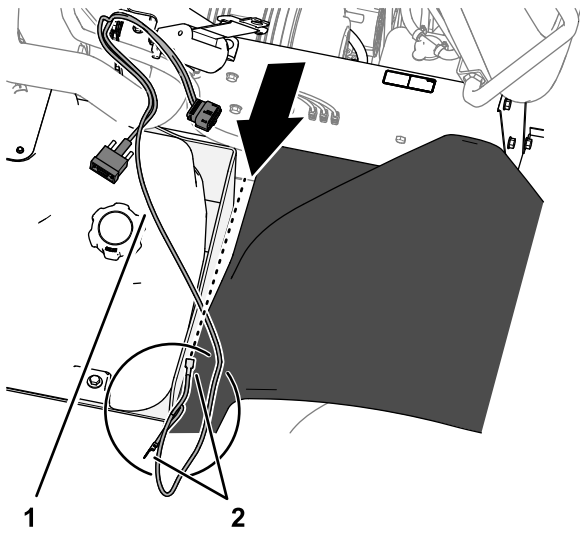

Figure 135

g310037

1. Modem power harness
2. Wire terminals

2. At the inboard side of the right seat box, route the modem power harness forward and power harness connector labeled RS232 along the machine wire harness.

Note: The connector labeled RS232 is not used.

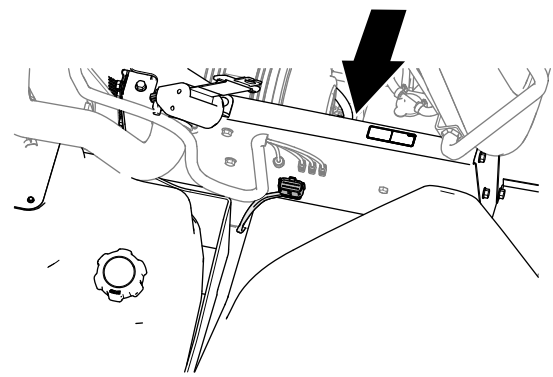

g310038

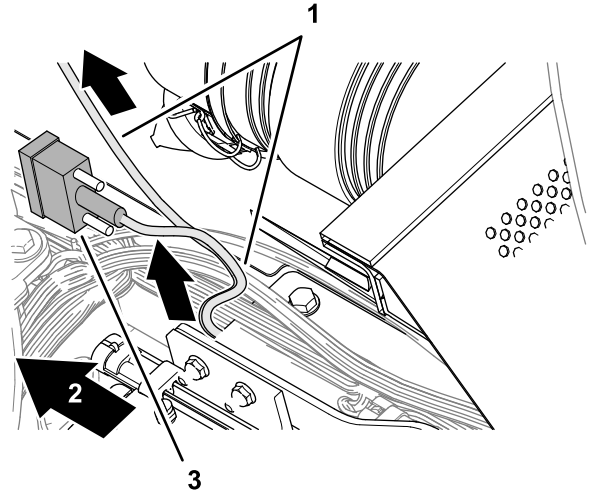
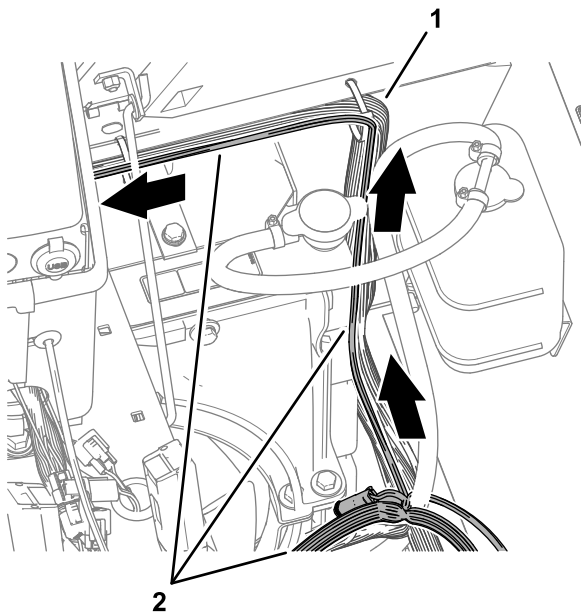

Figure 136

g310039

1. Modem power harness
3. 9-pin connector (labeled RS232—not used)
2. Front of the machine

3. Route the modem power harness across the top of the radiator, along the machine wire harness.



g301675

Figure 137

1. Machine wire harness
2. Modem power harness

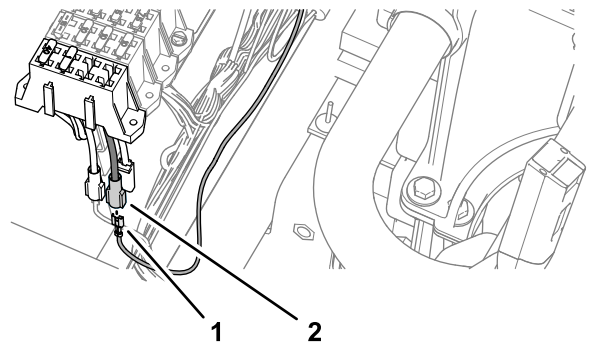

g301670

Figure 138

1. Terminal (labeled BATTERY—modem power harness)
2. Socket connector (options power—fuse block)

2. Insert the fuse (10 A) into the fuse-block socket for the options power circuit that you used in step 1.

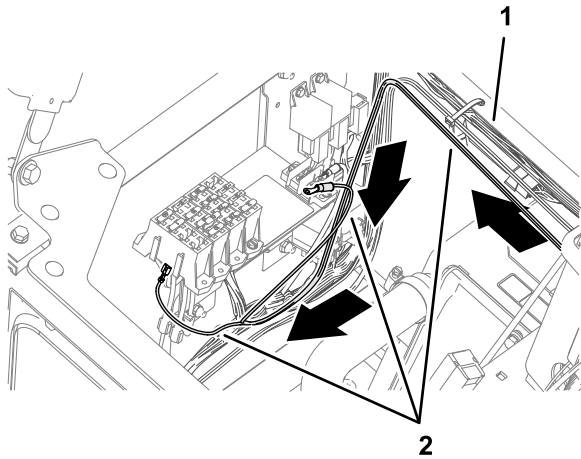

g301672

Figure 139

1. Fuse block
2. Fuse (10 A)

3. Secure the switched power and ground branch of the kit wire harness to the machine wire harness with 5 cable ties.

Connecting the Wire Harness to the Fuse Block

1. Plug the terminal of the modem power harness labeled SWITCHED into the socket connector for options power of the fuse block.

Note: If fuse block of your machine does not have an available options-power circuit, install an additional options-fuse block; refer to your authorized Toro distributor.

Routing the Harness to the Battery

1. Route the ring terminals of the harness labeled BATTERY and GROUND rearward, and over the seat support.

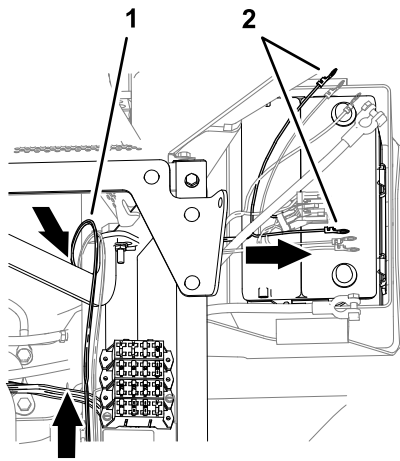

Figure 140

g315080

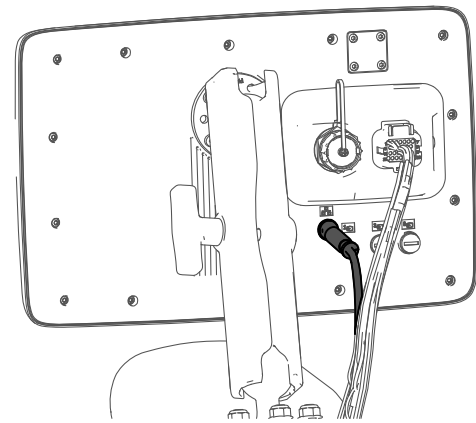

Figure 141

g420566

2. Route the ring terminals under the left frame tube and across the top of the battery.

Note: You will assemble the ring terminals to the battery cables in upcoming steps.

22

Assembling the Modem Data Harness to the Machine

Parts needed for this procedure:

1	Modem data harness—300 cm (118 inches)
8	Cable ties

Connecting the Modem Data Harness to the Display

Screw the modem harness connector into the display.

Routing the Modem Data Cable

1. Route the modem data cable through the storage compartment.
2. Route the modem data cable along the wire harness of the machine, and through the grommet in the floor plate.

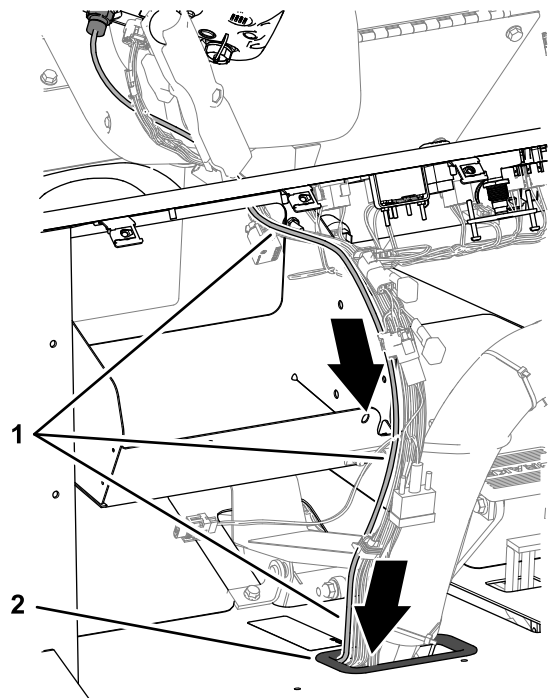

Figure 142

g310208

1. Modem data cable
2. Grommet (floor plate)

3. Secure the modem data cable to the machine wire harnesses with 4 cable ties.
4. At the bottom of the machine, route the modem data cable rearward, along the wire harness of the machine.

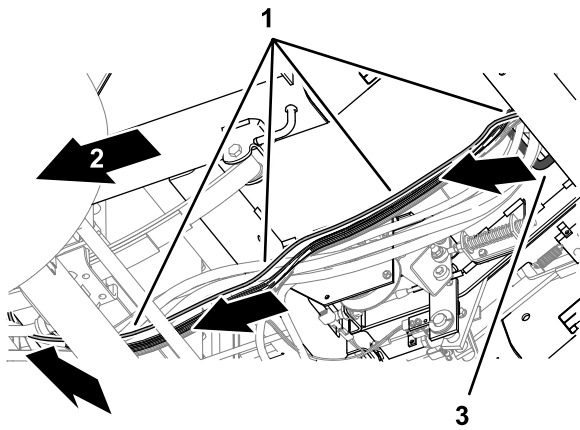

Figure 143

g310209

1. Modem data cable
2. Back of the machine
3. Grommet (floor plate)

5. At the rear side of the radiator, route the modem data cable upward.

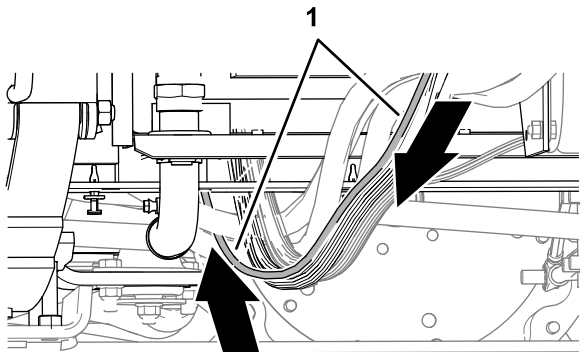
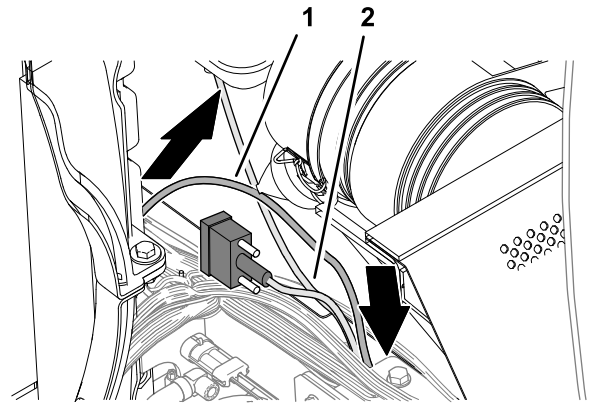

Figure 144

g310210

1. Modem data cable

6. Secure the modem data cable to the machine wire harnesses with 4 cable ties.
7. Route the modem data cable along the modem power harness, out the right side of the machine, and between the fuel tank bracket and the right, front fender.



g310211

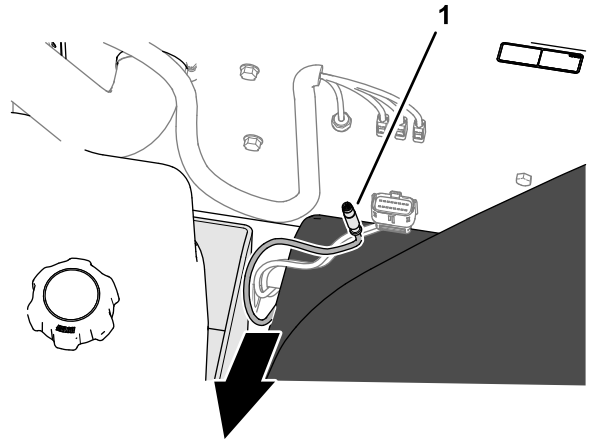

Figure 145

g310212

1. Modem data cable
2. Modem power harness

23

Installing the CL-55 Modem

Parts needed for this procedure:

1	CL-55 modem
1	Modem bracket
2	Bolt (#10 x 1-3/4 inch)
2	Spacer
2	Locknut (#10)

Connecting the Antenna Harness to the Modem

1. Plug the coaxial connector of the modem-antenna harness labeled WiFi into the coaxial port of the CL-55 modem marked WiFi/BT, and tighten the coaxial connector.

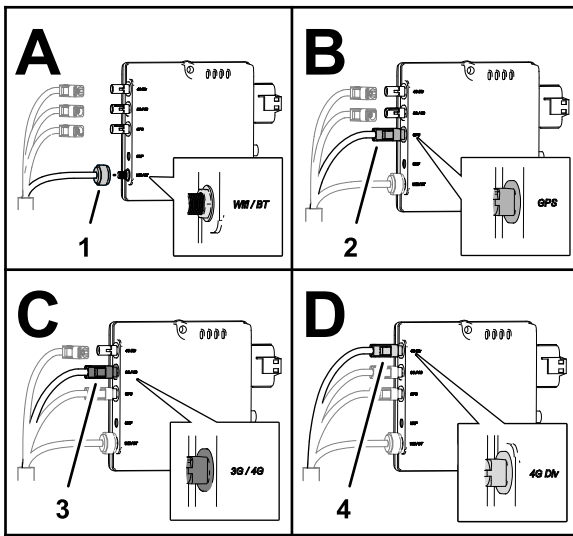

Figure 146

g310538

- | | |
|--|---|
| 1. Coaxial connector (labeled WiFi—modem-antenna harness) | 3. Violet coaxial push-in connector (labeled LTE-1—modem-antenna harness) |
| 2. Blue coaxial push-in connector (labeled GNSS—modem-antenna harness) | 4. Red coaxial push-in connector (labeled LTE-2—modem-antenna harness) |

- Plug the blue coaxial push-in connector of the modem-antenna harness labeled GNSS into the connector of the CL-55 modem marked GPS, until the connectors latch securely.
- Plug the violet coaxial push-in connector of the modem-antenna harness labeled LTE-1 into the connector of the CL-55 modem marked 3G / 4G, until the connectors latch securely.
- CDMA Modems Only:** Plug the red coaxial push-in connector of the modem-antenna harness labeled LTE-2 into the connector of the CL-55 modem marked 4G DIV, until the connectors latch securely.

Note: The GSM modem does not have an LTE-2 connector.

Connecting the Modem Data and Power Harnesses to the Modem

- Plug the 4-pin connector of the modem data harness labeled ETHERNET CL55 into the 4-socket connector (unmarked) of the CL-55 modem, and tighten the knurled nut of the 4-pin connector.

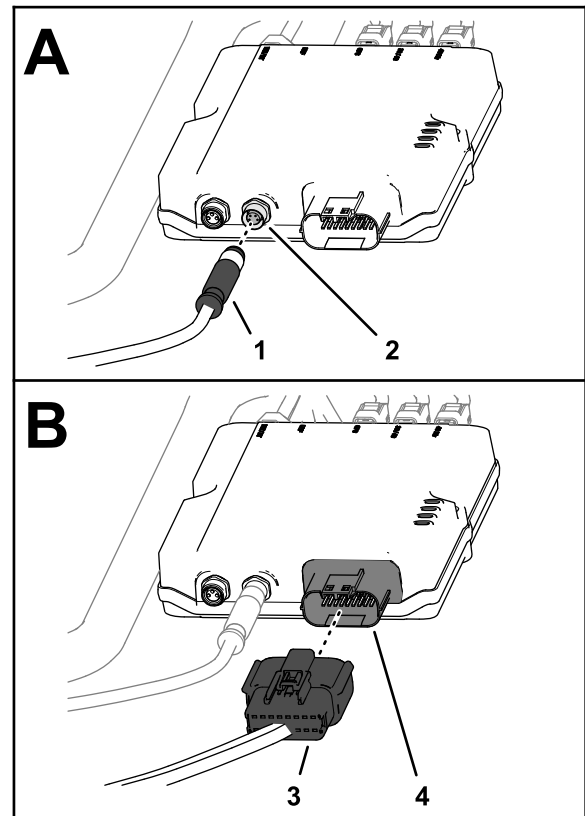

Figure 147

g310539

- | | |
|---|---|
| 1. 4-pin connector (labeled ETHERNET CL55—modem data harness) | 3. 18-socket connector (labeled CL55—modem power harness) |
| 2. 4-socket connector (unmarked—CL-55 modem) | 4. 18-pin connector (CL-55 modem) |

- Plug the 18-socket connector of the modem power harness labeled CL55 into the 18-pin connector of the CL-55 modem.

Installing the Modem to the Machine

- Secure the modem to the bracket using 2 bolts (#10 x 1-3/4 inch), 2 spacers, and 2 locknuts (#10)

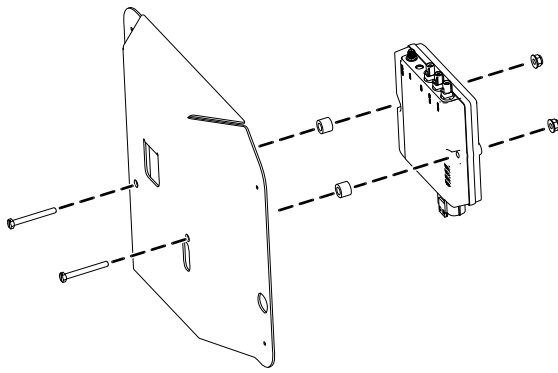

Figure 148

g423318

- Secure the magnets on the modem bracket with the rivets.

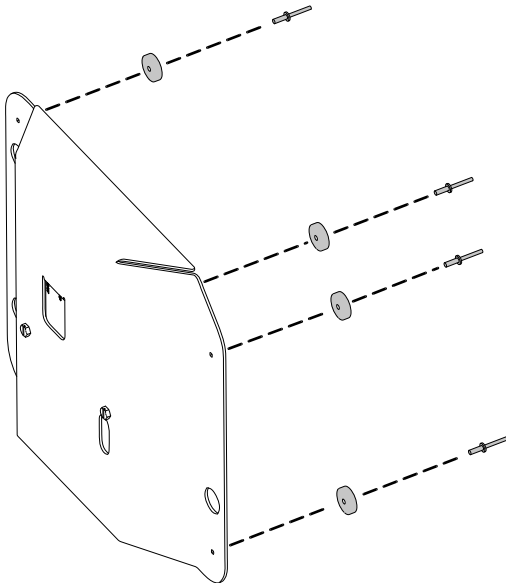

Figure 149

g423317

- Place the modem bracket to the right seat-box panel over the bolt heads.

Important: Ensure that the wire harnesses are routed within the modem bracket.

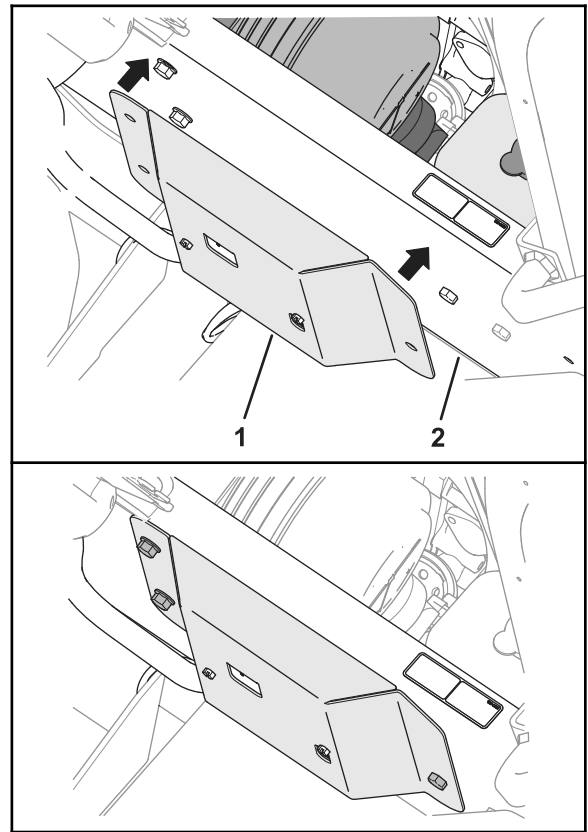

Figure 150

g338608

1. Modem bracket

2. Right seat-box panel

24

Routing the ISO-CAN Bus Harness

Parts needed for this procedure:

1	ISO-CAN bus harness—302 cm (119 inches)
12	Cable ties

Connecting the ISO-CAN Bus Harness to the GeoLink Harness

GeoLink Navigation Cable with a Convuluted-Tube Cover

- At the front of the machine, align the 4-pin connector of the ISO-CAN bus harness—302 cm (119 inches) labeled To ISOBUS toward the dash panel.

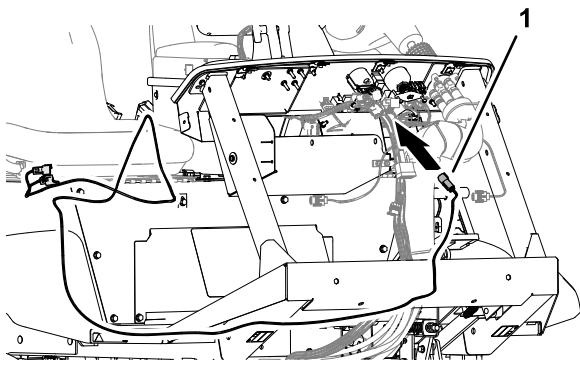

Figure 151

g308950

1. ISO-CAN bus harness—302 cm (119 inches) 4-pin connector labeled To ISOBUS

2. Remove the ISO bus terminator from the 4-socket connector of the GeoLink harness labeled CAN 1 ISOBUS TERMINATOR.

Note: You no longer need the cap.

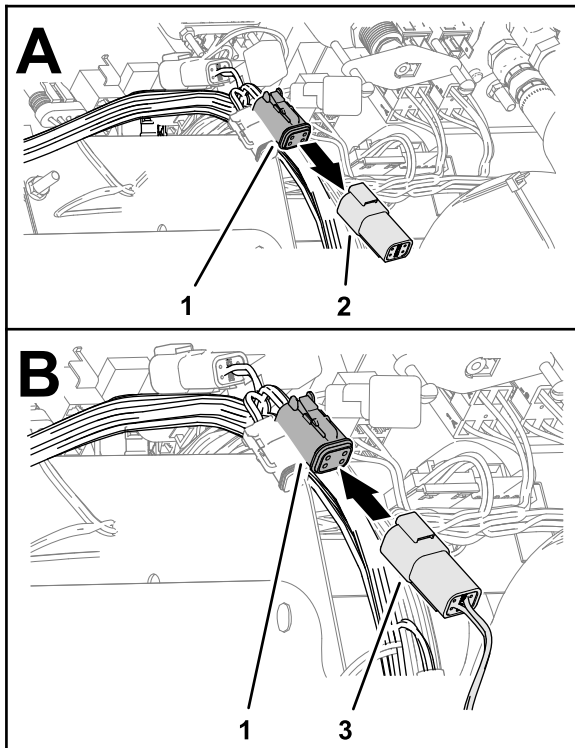

Figure 152

g308951

1. 4-socket connector (labeled CAN 1 ISOBUS TERMINATOR—GeoLink harness)
 2. Terminator (ISO bus)
 3. 4-pin connector (labeled To ISOBUS—ISO-CAN bus harness)
3. Plug the To ISOBUS connector of the ISO-CAN bus harness into the CAN 1 ISOBUS TERMINATOR connector of the GeoLink harness.

Routing the Harness to the Console Base

GeoLink Navigation Cable with a Convoluted-Tube Cover

1. Route the other end of the ISO-CAN bus harness through the grommet of the floor.

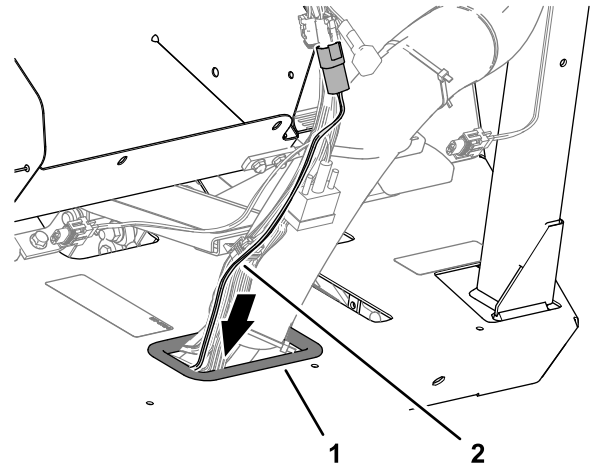

Figure 153

g308956

1. Grommet (floor)
2. ISO-CAN bus harness

2. Secure the ISO-CAN bus harness to the machine wire harness with 2 cable ties.
3. At the bottom of the machine, route the ISO-CAN bus harness along the wire harness of the machine.

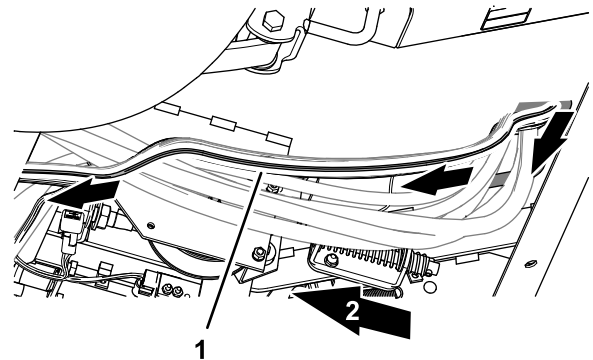

Figure 154

g308957

1. ISO-CAN bus harness
4. Secure the ISO-CAN bus harness to the machine wire harness with 3 cable ties.
 5. Rotate the passenger seat forward and support it with the prop rod.
 6. At the right side of the radiator, rout the ISO-CAN bus harness up, along the machine wire harness, and toward the center console.

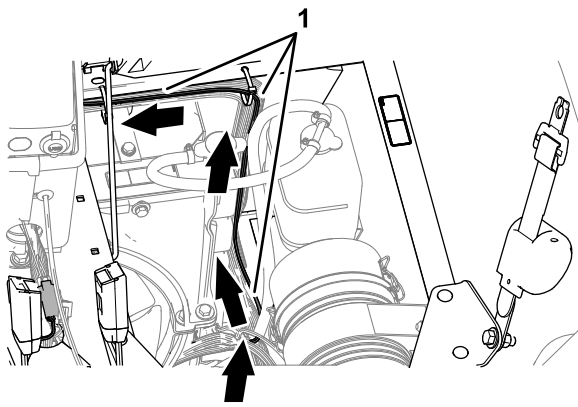

Figure 155

g308958

1. ISO-CAN bus harness

7. Route the ISO-CAN bus harness under the console base and along the machine wire harness.

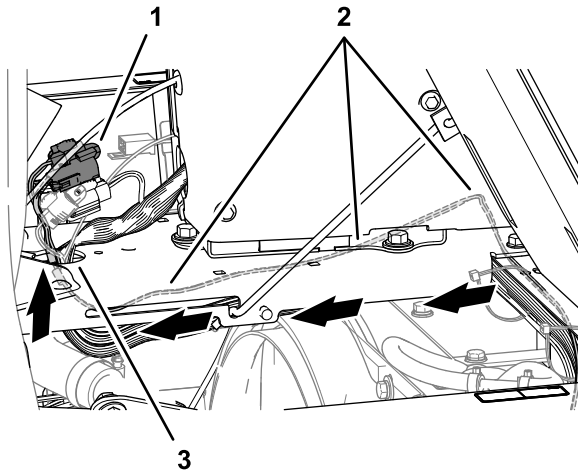

Figure 156

g308959

1. 3-pin connector (labeled To TORO CANBUS) and 3-socket connector (labeled CAN PORT A)
2. ISO-CAN bus harness
3. Hole (console base)

8. Route the 3-pin connector (labeled To TORO CANBUS) and 3-socket connector (labeled CAN PORT A) of the ISO-CAN bus harness through the hole in the console base.
9. Secure the ISO-CAN bus harness to the machine wire harness with 6 cable ties.

Connecting the ISO-CAN Bus Harness to the Machine Wire Harness

1. Remove the cap from the 3-socket connector of the machine wire harness (labeled CAN DIAGNOSTICS INTERCONNECT).

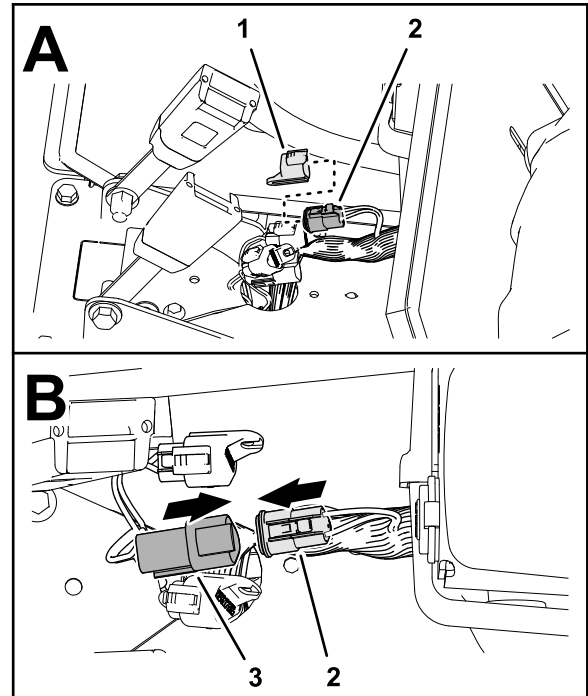

Figure 157

g308952

1. Cap
 2. 3-socket connector (labeled CAN DIAGNOSTICS INTERCONNECT—machine wire harness)
 3. 3-pin connector (labeled To TORO CANBUS—ISO-CAN bus harness)
2. Plug the 3-pin connector of the ISO-CAN bus harness (labeled To TORO CANBUS) into the 3-socket connector of the machine wire harness (labeled CAN DIAGNOSTICS INTERCONNECT).

25

Removing the CAN Bus Resistor

No Parts Required

Removing the Console Side Panel

1. Lower the passenger seat.
2. Remove 4 flange-head capscrews (1/4 x 3/4 inch) that secure the side panel of the center console.

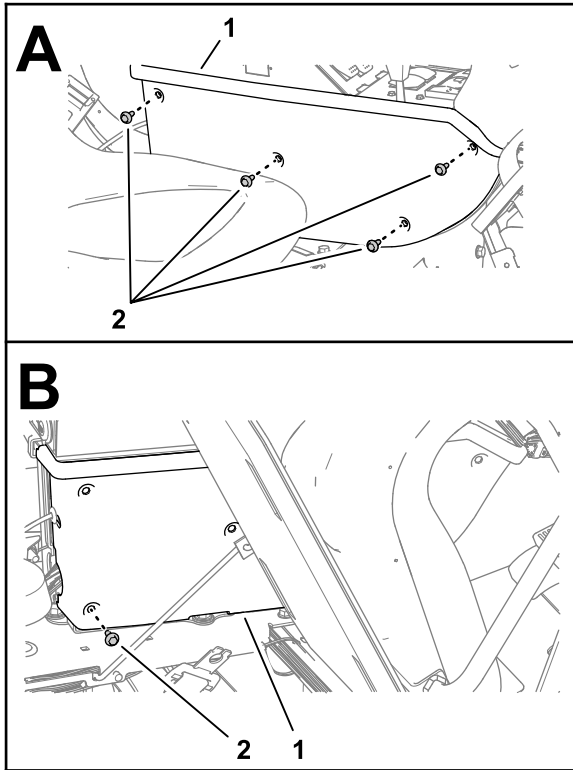

Figure 158

g301406

1. Side panel
2. Flange-head capscrews (1/4 x 3/4 inch)

3. Tilt the passenger seat forward, and remove the lower rear flange-head capscrew.
4. Remove the side panel from the center console.

Removing the Terminating Resistor

Forward of the TEC Controller, remove and retain the resistor 75Ω from the 3-socket connector (not labeled) of the machine wire harness.

Note: You will install the side panel to the center console when you install the AutoSteer Kit for the Multi Pro 5800 Turf Sprayer with GeoLink; refer to the setup instructions in the AutoSteer kit *Installation Instructions*.

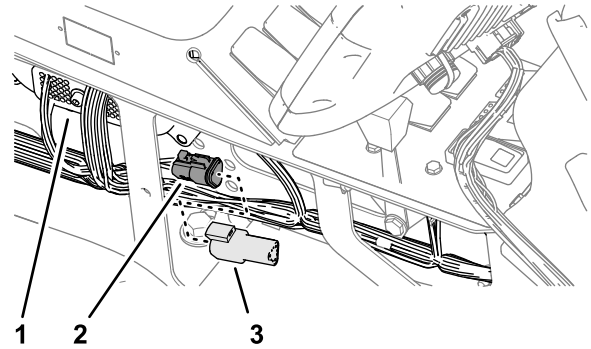

Figure 159

g308955

1. TEC controller
2. 3-socket connector (not labeled—machine wire harness)
3. Resistor 75Ω (3-pin)

Installing the Console Side Panel

1. Assemble the side panel to the console frame with 4 flange-head capscrews (1/4 x 3/4 inch).

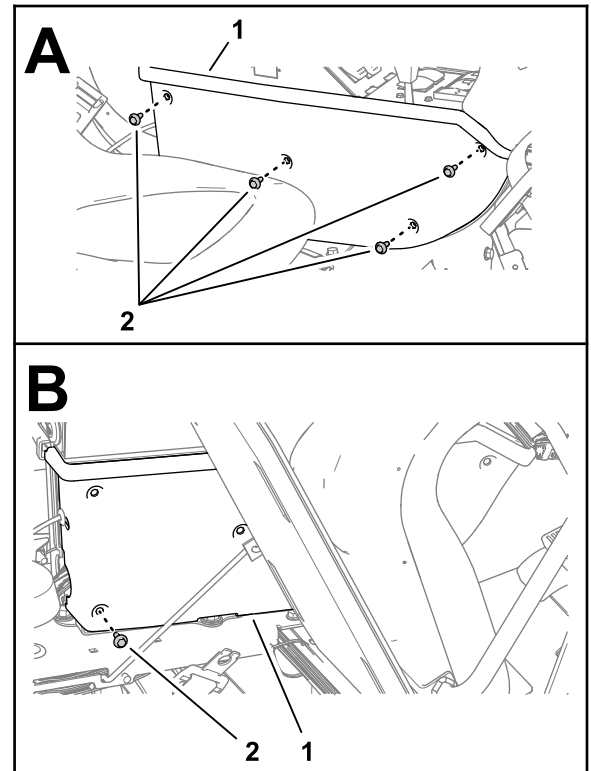

Figure 160

g301406

1. Side panel
2. Flange-head capscrews (1/4 x 3/4 inch)

2. Tilt the seat forward and install the lower rear flange-head capscrew.

26

Installing the Adapter Harness and Terminating Resistor

Parts needed for this procedure:

1	Adapter harness—13 cm (5 inches)
1	Cable tie

Procedure

1. At the satellite receiver and antenna, remove and discard the ISO bus terminator for the 6-socket connector.

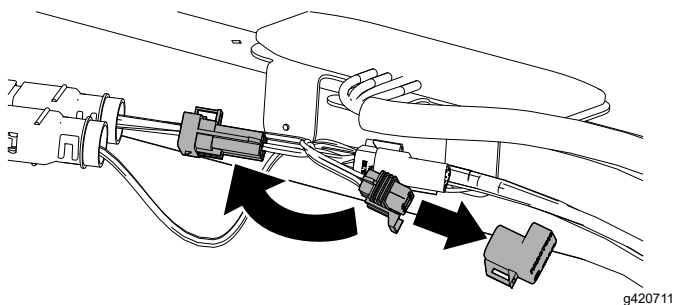

Figure 161

2. Plug the 6-pin connector of the adapter harness—13 cm (5 inches) into the 6-socket connector of the GeoLink harness.
3. Secure the adapter harness to the GeoLink harness with a cable tie.

27

Completing the Installation of the GeoLink Spray System-Finishing Kit

No Parts Required

Assembling the Rear GeoLink Harness, Navigation-Data and Electrical Harness, and Modem Power Harness to the Battery Cables

1. Route the positive terminal (red wire), negative terminal (black wire), and fuses block (50 A) of the rear wire harness up between the battery box and the chassis of the machine.

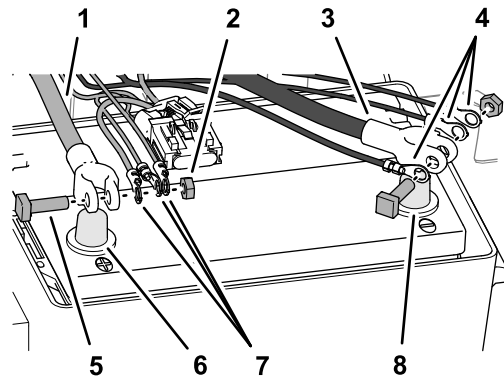

Figure 162

- | | |
|--|--|
| 1. Positive battery cable | 5. T-bolt |
| 2. Hex nut | 6. Battery post (positive) |
| 3. Negative battery cable | 7. Positive ring terminals (black wire)—rear GeoLink wire harness, navigation data and electrical harness, and modem power harness |
| 4. Negative-ring terminals (black wire)—rear GeoLink wire harness, navigation-data and electrical harness, and modem power harness | 8. Battery post (negative) |

2. Route the positive terminal (red wire), negative terminal (black wire), and 10 A fuse block of the navigation-electrical harness up between the battery box and the chassis of the machine.

3. Route the ring terminals labeled BATTERY and GROUND of the modem power harness up between the battery box and the chassis of the machine.
4. Remove the T-bolts and hex nuts from the terminals of the positive and negative battery cables (Figure 162).
5. Assemble a T-bolt through the positive terminal (red wire) of the rear wire harness, the positive terminal of the navigation-electrical harness, modem power harness, and terminal of the positive battery cable.
6. Loosely secure the terminals and the T-bolt with a hex nut.
7. Assemble a T-bolt through the negative terminal (black wire) of the rear wire harness, the negative terminal of the navigation-electrical harness, modem power harness, and terminal of the negative battery cable.
8. Loosely secure the terminals and the T-bolt with a hex nut.
9. Connect the battery; refer to the *Operator's Manual*.

Programming the Machine Settings

1. Insert the key into the key switch and rotate the switch to the ON position.

Note: Do not start the engine.
2. At the splash screen, press and hold the button 5 (far right) on the InfoCenter to access the Main Menu screen.



Figure 163

1. Button 5

3. On the Main Menu, press button 1 or button 2 until the Settings option is highlighted, and press button 4 to navigate to the Settings menus.

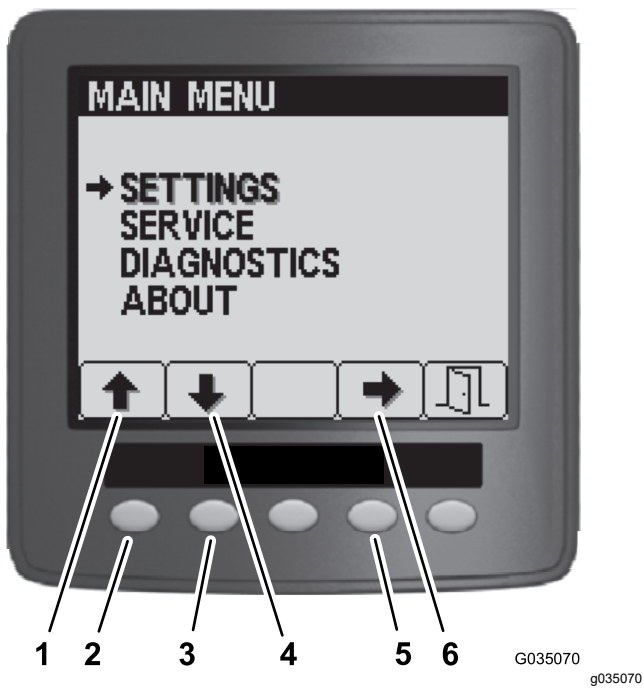

Figure 164

- | | |
|---------------|-----------------|
| 1. Up arrow | 4. Button 2 |
| 2. Button 1 | 5. Button 4 |
| 3. Down arrow | 6. Select arrow |

4. On the Settings menu, press button 1 or button 2 until the GeoLink option is highlighted, and press button 4 to navigate to the GeoLink menu.

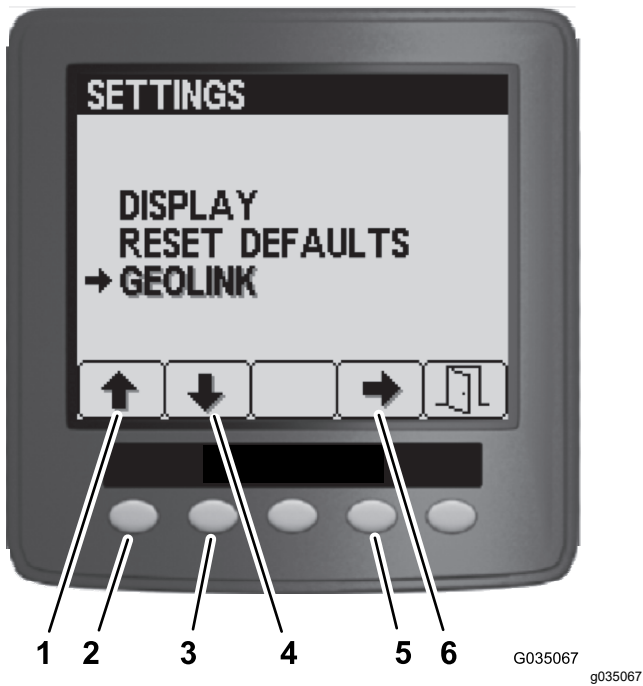

Figure 165

- | | |
|---------------|-----------------|
| 1. Up arrow | 4. Button 2 |
| 2. Button 1 | 5. Button 4 |
| 3. Down arrow | 6. Select arrow |

5. On the GeoLink menu, press button 4 to select the Yes option, and press the button 5 to save your settings and exit the menu.

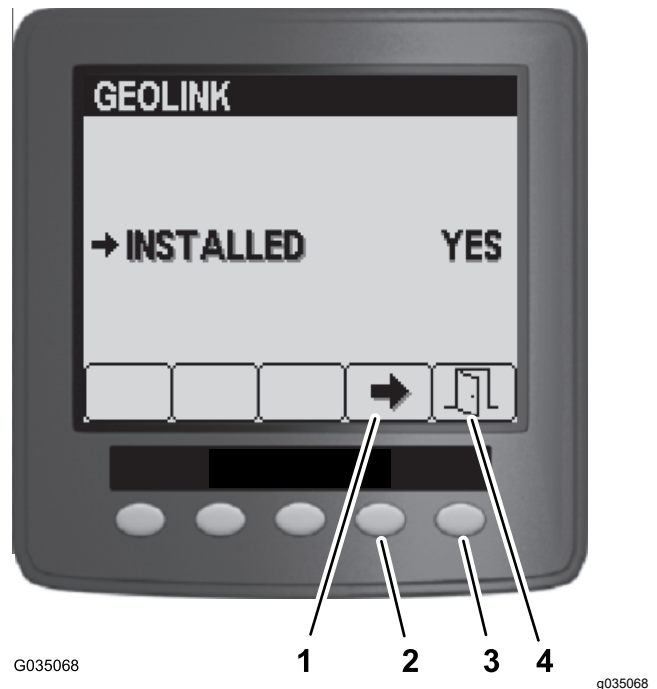

Figure 166

- | | |
|-----------------|-------------|
| 1. Button 4 | 3. Button 5 |
| 2. Select arrow | 4. Exit |

6. Rotate the key switch to the OFF position.



Figure 167

7. Rotate the key switch to the ON position.

Note: The splash screen for the GeoLink system should display in the InfoCenter.



G035066

Figure 168

g035066

8. Rotate the key switch to the OFF position.

28

Powering the GeoLink Components

No Parts Required

Procedure

1. Turn the ignition key to the ON position.
2. Verify that the following components indicate that each receives power:
 - Control console—displays graphics and text



Figure 169

g423361

- Satellite receiver—the PWR indicator illuminates

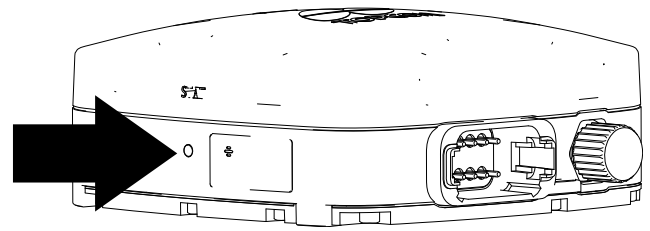

Figure 170

g423320

- Modem—the LED indicators illuminate.

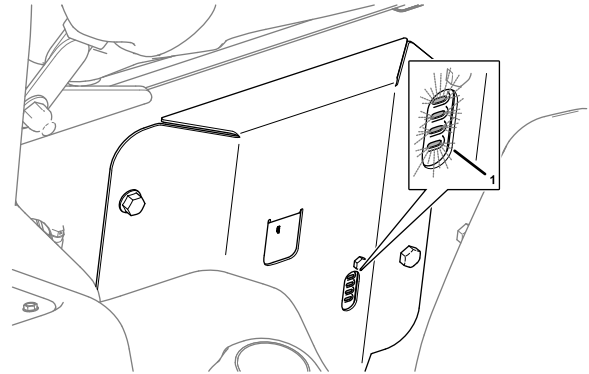

Figure 171

g306264

1. LED Indicators (passenger seat base)

- Automatic section controller—the STATUS indicator illuminates

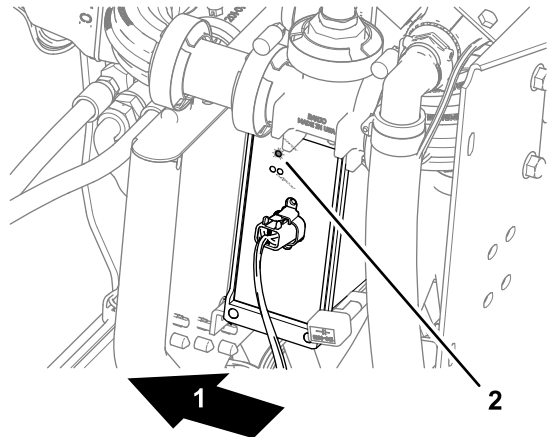

Figure 172

g302923

1. Back of the machine
2. STATUS indicator (automatic section controller)

3. Turn the ignition key to the OFF position.
4. Verify that power is shut off at the following components:
 - Control console
 - Satellite receiver
 - Automatic section controller

29

Completing the Software Setup

No Parts Required

Procedure

Refer to the *Software Guide* for your GeoLink system.

Complete the following procedures:

1. Verify the software version.
2. Select the units of measure.
3. Create a field.
4. Create a new product and application rate.
5. Create a spray task.
6. Checking the spray system.
7. Balance the agitation bypass valve.
8. Calibrate the flow meter.
9. Verify the cellular status.
10. Calibrate the compass at the distributor location.
11. Clear the NVRAM at the customer location.
12. Calibrate the compass at the customer location.

Notes:



The Toro Warranty

Two-Year or 1,500 Hours Limited Warranty

Conditions and Products Covered

The Toro Company warrants your Toro Commercial product ("Product") to be free from defects in materials or workmanship for 2 years or 1,500 operational hours*, whichever occurs first. This warranty is applicable to all products with the exception of Aerators (refer to separate warranty statements for these products). Where a warrantable condition exists, we will repair the Product at no cost to you including diagnostics, labor, parts, and transportation. This warranty begins on the date the Product is delivered to the original retail purchaser.

* Product equipped with an hour meter.

Instructions for Obtaining Warranty Service

You are responsible for notifying the Commercial Products Distributor or Authorized Commercial Products Dealer from whom you purchased the Product as soon as you believe a warrantable condition exists. If you need help locating a Commercial Products Distributor or Authorized Dealer, or if you have questions regarding your warranty rights or responsibilities, you may contact us at:

Toro Commercial Products Service Department
8111 Lyndale Avenue South
Bloomington, MN 55420-1196

952-888-8801 or 800-952-2740
E-mail: commercial.warranty@toro.com

Owner Responsibilities

As the product owner, you are responsible for required maintenance and adjustments stated in your *Operator's Manual*. Repairs for product issues caused by failure to perform required maintenance and adjustments are not covered under this warranty.

Items and Conditions Not Covered

Not all product failures or malfunctions that occur during the warranty period are defects in materials or workmanship. This warranty does not cover the following:

- Product failures which result from the use of non-Toro replacement parts, or from installation and use of add-on, or modified non-Toro branded accessories and products.
- Product failures which result from failure to perform recommended maintenance and/or adjustments.
- Product failures which result from operating the Product in an abusive, negligent, or reckless manner.
- Parts consumed through use that are not defective. Examples of parts which are consumed, or used up, during normal Product operation include, but are not limited to, brake pads and linings, clutch linings, blades, reels, rollers and bearings (sealed or greasable), bed knives, spark plugs, castor wheels and bearings, tires, filters, belts, and certain sprayer components such as diaphragms, nozzles, flow meters, and check valves.
- Failures caused by outside influence, including, but not limited to, weather, storage practices, contamination, use of unapproved fuels, coolants, lubricants, additives, fertilizers, water, or chemicals.
- Failure or performance issues due to the use of fuels (e.g. gasoline, diesel, or biodiesel) that do not conform to their respective industry standards.
- Normal noise, vibration, wear and tear, and deterioration. Normal "wear and tear" includes, but is not limited to, damage to seats due to wear or abrasion, worn painted surfaces, scratched decals or windows.

Countries Other than the United States or Canada

Customers who have purchased Toro products exported from the United States or Canada should contact their Toro Distributor (Dealer) to obtain guarantee policies for your country, province, or state. If for any reason you are dissatisfied with your Distributor's service or have difficulty obtaining guarantee information, contact your Authorized Toro Service Center.

Parts

Parts scheduled for replacement as required maintenance are warranted for the period of time up to the scheduled replacement time for that part. Parts replaced under this warranty are covered for the duration of the original product warranty and become the property of Toro. Toro will make the final decision whether to repair any existing part or assembly or replace it. Toro may use remanufactured parts for warranty repairs.

Deep Cycle and Lithium-Ion Battery Warranty

Deep cycle and Lithium-Ion batteries have a specified total number of kilowatt-hours they can deliver during their lifetime. Operating, recharging, and maintenance techniques can extend or reduce total battery life. As the batteries in this product are consumed, the amount of useful work between charging intervals will slowly decrease until the battery is completely worn out. Replacement of worn out batteries, due to normal consumption, is the responsibility of the product owner. Note: (Lithium-Ion battery only): Refer to the battery warranty for additional information.

Lifetime Crankshaft Warranty (ProStripe 02657 Model Only)

The Prostripe which is fitted with a genuine Toro Friction Disc and Crank-Safe Blade Brake Clutch (integrated Blade Brake Clutch (BBC) + Friction Disc assembly) as original equipment and used by the original purchaser in accordance with recommended operating and maintenance procedures, are covered by a Lifetime Warranty against engine crankshaft bending. Machines fitted with friction washers, Blade Brake Clutch (BBC) units and other such devices are not covered by the Lifetime Crankshaft Warranty.

Maintenance is at Owner's Expense

Engine tune-up, lubrication, cleaning and polishing, replacement of filters, coolant, and completing recommended maintenance are some of the normal services Toro products require that are at the owner's expense.

General Conditions

Repair by an Authorized Toro Distributor or Dealer is your sole remedy under this warranty.

The Toro Company is not liable for indirect, incidental or consequential damages in connection with the use of the Toro Products covered by this warranty, including any cost or expense of providing substitute equipment or service during reasonable periods of malfunction or non-use pending completion of repairs under this warranty. Except for the Emissions warranty referenced below, if applicable, there is no other express warranty. All implied warranties of merchantability and fitness for use are limited to the duration of this express warranty.

Some states do not allow exclusions of incidental or consequential damages, or limitations on how long an implied warranty lasts, so the above exclusions and limitations may not apply to you. This warranty gives you specific legal rights, and you may also have other rights which vary from state to state.

Note Regarding Emissions Warranty

The Emissions Control System on your Product may be covered by a separate warranty meeting requirements established by the U.S. Environmental Protection Agency (EPA) and/or the California Air Resources Board (CARB). The hour limitations set forth above do not apply to the Emissions Control System Warranty. Refer to the Engine Emission Control Warranty Statement supplied with your product or contained in the engine manufacturer's documentation.



Count on it.