



**Z287L**

**Z Master<sup>®</sup> with 72" SFS Side Discharge Mower**

**Model No. 74214—Serial No. 230006001 and Up**

**Operator's Manual**



## Warning



**The engine exhaust from this product contains chemicals known to the State of California to cause cancer, birth defects, or other reproductive harm.**

Because in some areas there are local, state, or federal regulations requiring that a spark arrester be used on the engine of this mower, a spark arrester is incorporated with the muffler assembly.

**Important** This engine is equipped with a spark arrester muffler. It is a violation of California Public Resource Code Section 4442 to use or operate this engine without a spark arrester muffler on any forest-covered, brush-covered, or grass-covered land. Other states or federal areas may have similar laws.

This spark ignition system complies with Canadian ICES-002.

Ce système d'allumage par étincelle de véhicule est conforme à la norme NMB-002 du Canada.

**The enclosed Engine Owner's Manual is supplied for information regarding The U.S. Environmental Protection Agency (EPA) and the California Emission Control Regulation of emission systems, maintenance and warranty.**

**Keep this engine Owner's Manual with your unit. Should this engine Owner's Manual become damaged or illegible, replace immediately. Replacements may be ordered through the engine manufacturer.**

# Contents

	Page
Introduction .....	3
Safety .....	3
Safe Operating Practices .....	3
Slope Chart .....	6
Safety and Instruction Decals .....	8
Gasoline and Oil .....	13
Recommended Gasoline .....	13
Using Stabilizer/Conditioner .....	13
Filling the Fuel Tank .....	13
Checking the Engine Oil Level .....	13
Setup .....	14
Loose Parts .....	14
Installing the Drive Wheels .....	14
Checking the Tire Pressure .....	14
Installing the Seat .....	15
Installing the Motion Control Levers .....	15
Activating the Battery .....	16

	Page
Checking the Engine Oil Level .....	16
Checking the Side Discharge Chute .....	16
Checking the Leveling of the Mower Deck .....	16
Checking the Radiator Coolant .....	16
Greasing the Bearings .....	16
Checking the Hydraulic Fluid .....	17
Operation .....	17
Think Safety First .....	17
Controls .....	18
Operating the Parking Brake .....	18
Starting and Stopping the Engine .....	19
Operating the Power Take Off (PTO) .....	20
The Safety Interlock System .....	20
Driving Forward or Backward .....	21
Stopping the Machine .....	21
Adjusting the Height-of-Cut .....	21
Adjusting the Anti-Scalp Rollers .....	22
Positioning the Seat .....	22
Pushing the Machine by Hand .....	23
Using a Rollover Protection System (ROPS) ....	23
Transporting the Machine .....	23
Loading Machines .....	24
Using the Z Stand .....	24
Using the Lift Assist Lever .....	25
Tips for Mowing Grass .....	26
Maintenance .....	27
Recommended Maintenance Schedule .....	27
Servicing the Cutting Blades .....	28
Servicing the Air Cleaner .....	30
Servicing the Engine Oil .....	30
Servicing the Cooling System .....	32
Servicing the Spark Plug .....	34
Replacing the Fuel Filter .....	35
Draining the Fuel Tank .....	35
Servicing the Spark Arrester .....	36
Greasing and Lubrication .....	36
Checking the Tire Pressure .....	37
Servicing the Hydraulic System .....	37
Adjusting the Handle Neutral .....	39
Setting the Hydraulic Pump Neutral .....	40
Adjusting the Tracking .....	41
Adjusting the Caster Pivot Bearing .....	42
Checking the Wheel Hub Slotted Nut .....	42
Adjusting the Mower Level .....	42
Cleaning Under the Deck .....	43
Belt Inspection .....	43
Replacing the Deck Belt .....	44
Replacing the PTO Drive Belt .....	44
Replacing the Pump Drive Belt .....	46

	Page
Adjusting the Parking Brake .....	46
Servicing the Fuses .....	46
Servicing the Battery .....	47
Waste Disposal .....	49
Mercury Tilt Switch .....	49
Mercury Tilt Switch Disposal .....	49
Wiring Diagram .....	50
Cleaning and Storage .....	51
Troubleshooting .....	52
The Toro Total Coverage Guarantee .....	56

# Introduction

Read this manual carefully to learn how to operate and maintain your product properly. The information in this manual can help you and others avoid injury and product damage. Although Toro designs and produces safe products, you are responsible for operating the product properly and safely.

Whenever you need service, genuine Toro parts, or additional information, contact an Authorized Service Dealer or Toro Customer Service and have the model and serial numbers of your product ready. Figure 1 illustrates the location of the model and serial numbers on the product.

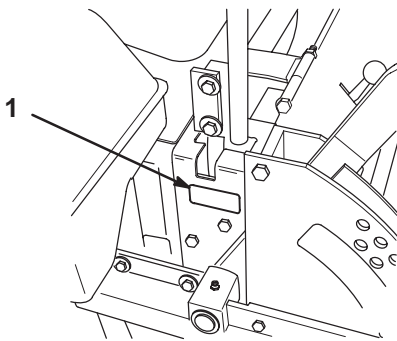

**Figure 1**

1. Location of the model and serial numbers

Write the product model and serial numbers in the space below:

<p><b>Model No.</b> _____</p> <p><b>Serial No.</b> _____</p>
--

This manual identifies potential hazards and has special safety messages that help you and others avoid personal injury and even death. **Danger**, **Warning**, and **Caution** are signal words used to identify the level of hazard. However, regardless of the hazard, be extremely careful.

**Danger** signals an extreme hazard that *will* cause serious injury or death if you do not follow the recommended precautions.

**Warning** signals a hazard that *may* cause serious injury or death if you do not follow the recommended precautions.

**Caution** signals a hazard that may cause minor or moderate injury if you do not follow the recommended precautions.

This manual uses two other words to highlight information.

**Important** calls attention to special mechanical information and **Note**: emphasizes general information worthy of special attention.

# Safety

**This machine meets or exceeds the B71.4 1999 specifications of the American National Standards Institute, in effect at time of production.**

**Note:** The addition of attachments made by other manufacturers that do not meet American National Standards Institute certification will cause noncompliance of this machine.

**Improper use or maintenance by the operator or owner can result in injury. To reduce the potential for injury, comply with these safety instructions and always pay attention to the safety alert ▲ symbol, which means CAUTION, WARNING, or DANGER—“personal safety instruction.” Failure to comply with the instruction may result in personal injury or death.**

This product is capable of amputating hands and feet and throwing objects. Always follow all safety instructions to avoid serious injury or death.

This product is designed for cutting and recycling grass or, when equipped with a grass bagger, for catching cut grass. Any use for purposes other than these could prove dangerous to user and bystanders.

## Safe Operating Practices

The following instructions are from ANSI standard B71.4—1999.

### Training

- Read the Operator’s Manual and other training material. If the operator(s) or mechanic(s) can not read English it is the owner’s responsibility to explain this material to them.

- Become familiar with the safe operation of the equipment, operator controls, and safety signs.
- All operators and mechanics should be trained. The owner is responsible for training the users.
- Never let children or untrained people operate or service the equipment. Local regulations may restrict the age of the operator.
- The owner/user can prevent and is responsible for accidents or injuries occurring to himself or herself, other people or property.

## Preparation

- Evaluate the terrain to determine what accessories and attachments are needed to properly and safely perform the job. Only use accessories and attachments approved by the manufacturer.
- Wear appropriate clothing including hard hat, safety glasses and hearing protection. Long hair, loose clothing or jewelry may get tangled in moving parts.
- Inspect the area where the equipment is to be used and remove all objects such as rocks, toys and wire which can be thrown by the machine.
- Use extra care when handling gasoline and other fuels. They are flammable and vapors are explosive.
  - Use only an approved container
  - Never remove gas cap or add fuel with engine running. Allow engine to cool before refueling. Do not smoke.
  - Never refuel or drain the machine indoors.
- Check that operator's presence controls, safety switches and shields are attached and functioning properly. Do not operate unless they are functioning properly.

## Operation

- Never run an engine in an enclosed area.
- Only operate in good light, keeping away from holes and hidden hazards.
- Be sure all drives are in neutral and parking brake is engaged before starting engine. Start the engine only from the operator's position.
- Never raise deck with the blades running.
- Never operate without the PTO shield, or other guards securely in place. Be sure all interlocks are functioning properly.
- Never operate with the discharge deflector raised, removed or altered, unless using a grass catcher.

- Do not change the engine governor setting or overspeed the engine.
- Stop on level ground, lower implements, disengage drives, engage parking brake, shut off engine before leaving the operator's position for any reason including emptying the catchers or unclogging the chute.
- Stop equipment and inspect blades after striking objects or if an abnormal vibration occurs. Make necessary repairs before resuming operations.
- Keep hands and feet away from the cutting units.
- Never carry passengers and keep pets and bystanders away.
- Be alert, slow down and use caution when making turns. Look behind and to the side before changing directions.
- Slow down and use caution when crossing roads and sidewalks. Stop blades if not mowing.
- Be aware of the mower discharge direction and do not point it at anyone.
- Do not operate the mower under the influence of alcohol or drugs.
- Use extreme care when loading or unloading the machine into a trailer or truck.
- Use care when approaching blind corners, shrubs, trees, or other objects that may obscure vision.

## Slope Operation

- Do not mow slopes greater than 15 degrees.
- Do not mow near drop-offs, ditches, steep banks or water. Wheels dropping over edges can cause rollovers, which may result in serious injury, death or drowning.
- Do not mow slopes when grass is wet. Slippery conditions reduce traction and could cause sliding and loss of control.
- Do not make sudden turns or rapid speed changes.
- Use a walk behind mower and/or a hand trimmer near drop-offs, ditches, steep banks or water.
- Reduce speed and use extreme caution on slopes.
- Remove or mark obstacles such as rocks, tree limbs, etc. from the mowing area. Tall grass can hide obstacles.
- Watch for ditches, holes, rocks, dips, and rises that change the operating angle, as rough terrain could overturn the machine.
- Avoid sudden starts when mowing uphill because the mower may tip backwards.

- Be aware that loss of traction may occur going downhill. Weight transfer to the front wheels may cause drive wheels to slip and cause loss of braking and steering.
- Always avoid sudden starting or stopping on a slope. If tires lose traction, disengage the blades and proceed slowly off the slope.
- Follow the manufacturer's recommendations for wheel weights or counterweights to improve stability.
- Use extreme care with grass catchers or other attachments. These can change the stability of the machine and cause loss of control.
- Keep hands and feet away from moving parts. If possible, do not make adjustments with the engine running.
- Charge batteries in an open well ventilated area, away from spark and flames. Unplug charger before connecting or disconnecting from battery. Wear protective clothing and use insulated tools.
- Keep all parts in good working condition and all hardware tightened. Replace all worn or damaged decals.
- Use only Toro-approved attachments. Warranty may be voided if used with unapproved attachments.

### **Using the Rollover Protection System (ROPS)**

- A rollbar is available and its use is recommended for areas where there are slopes, drop-offs or water.
- When operating a machine with ROPS always use the seat belt.
- Be certain that the seat belt can be released quickly if the machine is driven or rolls into ponds or water.
- Check carefully for overhead clearances (i.e. branches, doorways, electrical wires) before driving under any objects and do not contact them.

### **Maintenance and storage**

- Disengage drives, lower implement, set parking brake, stop engine and remove key or disconnect spark plug wire. Wait for all movement to stop before adjusting, cleaning or repairing.
- Clean grass and debris from cutting units, drives, mufflers, and engine to help prevent fires. Clean up oil or fuel spillage.
- Let engine cool before storing and do not store near flame.
- Shut off fuel while storing or transporting. Do not store fuel near flames or drain indoors.
- Park machine on level ground. Never allow untrained personnel to service machine.
- Use jack stands to support components when required.
- Carefully release pressure from components with stored energy.
- Disconnect battery or remove spark plug wire before making any repairs. Disconnect the negative terminal first and the positive last. Reconnect positive first and negative last.
- Use care when checking blades. Wrap the blade(s) or wear gloves, and use caution when servicing them. Only replace blades. Never straighten or weld them.

# Slope Chart

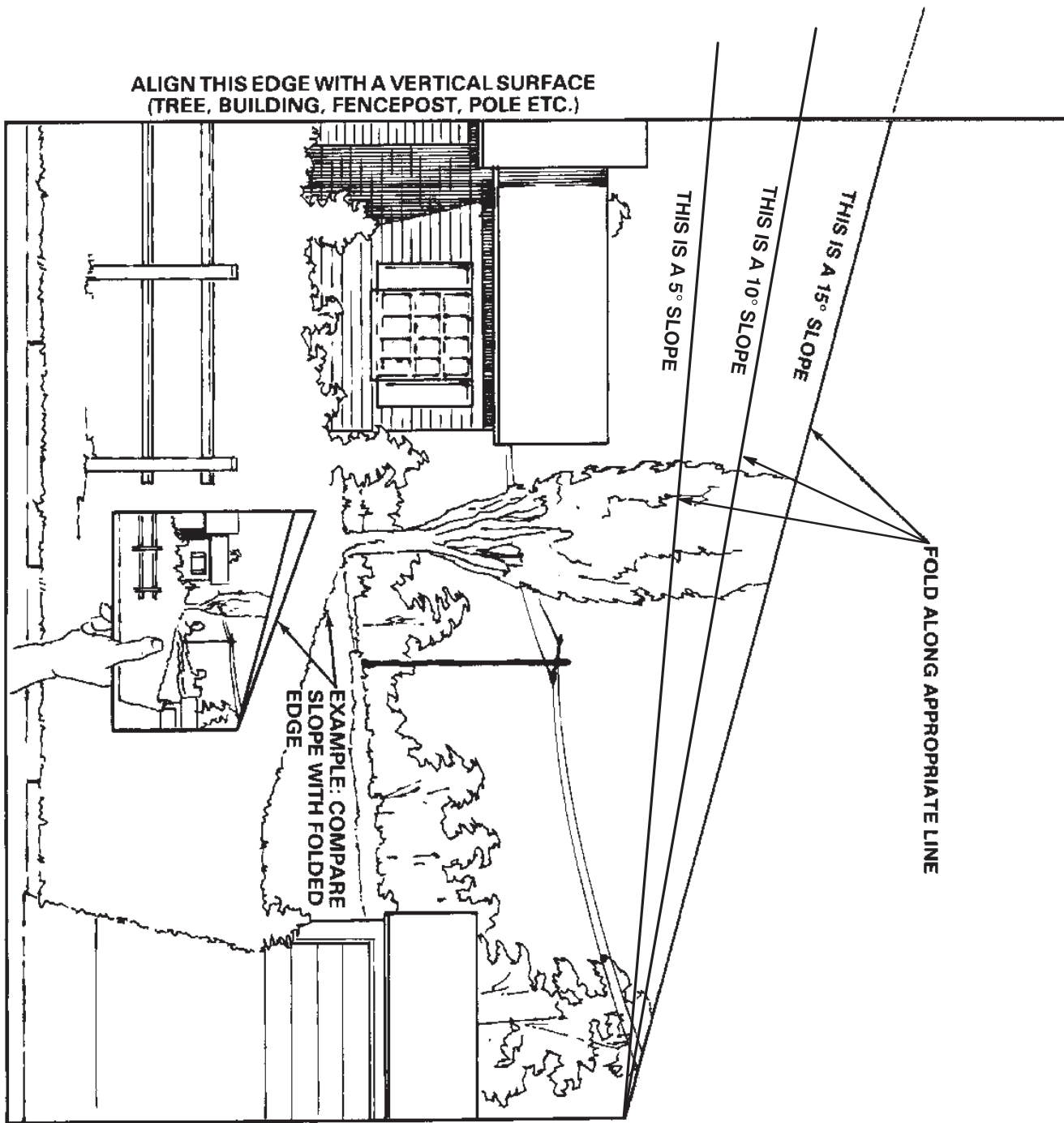



# Safety and Instruction Decals



Safety decals and instructions are easily visible to the operator and are located near any area of potential danger. Replace any decal that is damaged or lost.



1-633345



1-523552

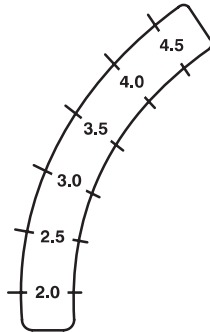

1-633706

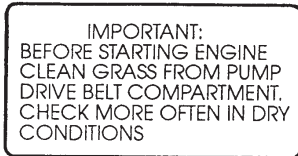

1-633462

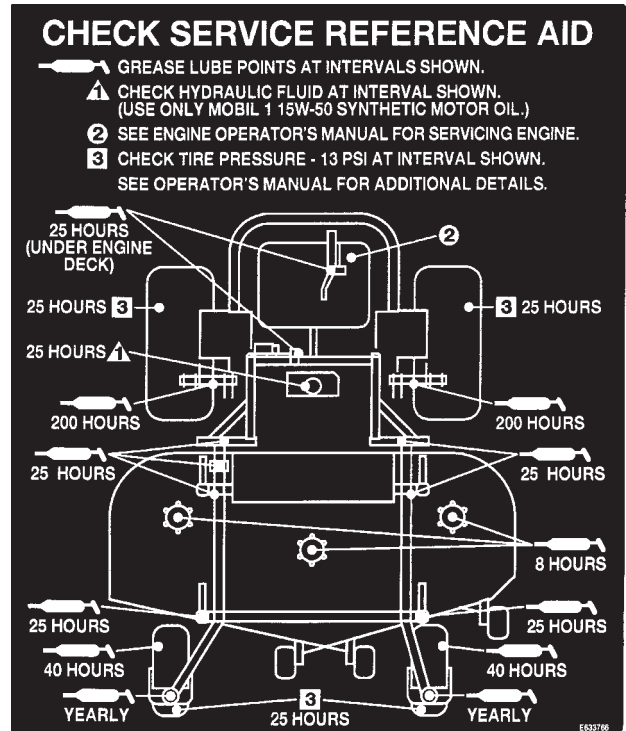

1-633766

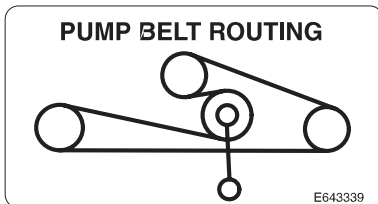

1-643339



1-643401



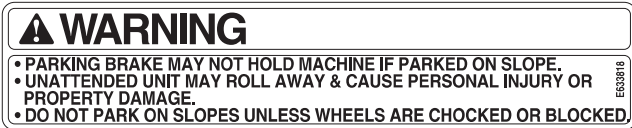

1-633818



43-8480



66-1340



67-5360



1-643253



65-2690



93-1122

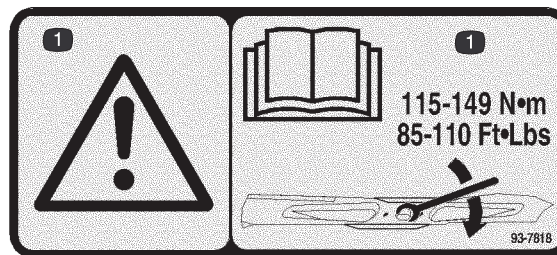

93-7818

1. Warning—read the *Operator's Manual* for instructions on torquing the blade bolt/nut to 115–149 N•m (85–110 ft.-lb.).

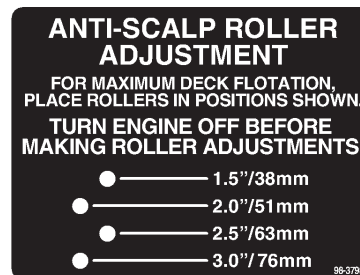

98-3798



98-4387

1. Warning—wear hearing protection.



103-1027

**TORO** LANDSCAPE CONTRACTOR EQUIPMENT

THIS COOLING SYSTEM PROTECTED BY:

**HAVOLINE® EXTENDED LIFE ANTI-FREEZE/COOLANT DEX-COOL**

TOP OFF ONLY WITH HAVOLINE® EXTENDED LIFE ANTI-FREEZE/COOLANT DEX-COOL.

SUGGESTED CHANGE INTERVAL IS AT 4 YEARS OR 4,000 HOURS OF SERVICE.

DO NOT MIX WITH CONVENTIONAL COOLANT.

HAVOLINE® EXTENDED LIFE ANTI-FREEZE/COOLANT IS AVAILABLE AT YOUR LOCAL AUTO PARTS STORE.

104-2449

104-2449



98-5954

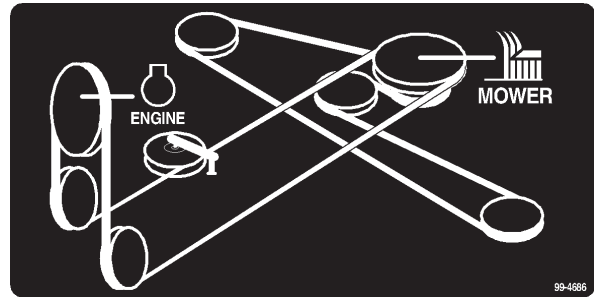

99-4686

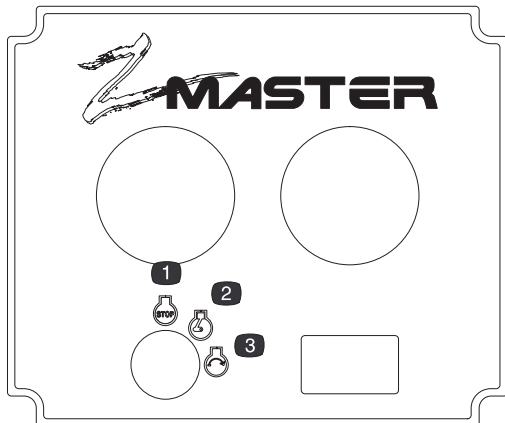

99-4612

1. Engine stop
2. Engine run
3. Engine start

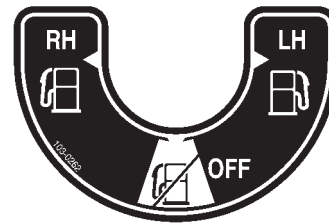

103-0262

**WARNING**

ROTATING MECHANICAL DEVICES CAN CAUSE SERIOUS INJURY!

- DO NOT operate without guards in place
- Stop engine before opening cover

103-0368

103-0368

NO. 1 2 3 4 5 6

See important warning information on side label!  
 Voir information d'avertissement importante sur l'étiquette de côté!  
 ¡Aviso importante favor de observar las instrucciones en la etiqueta lateral!

3-4479

104-4163

1. Explosion hazard
2. No fire, open flames, or smoking.
3. Caustic liquid/chemical burn hazard
4. Wear eye protection
5. Read the *Operator's Manual*.
6. Keep bystanders a safe distance from the battery.

**WARNING**

IMPROPER OPERATION AND PLACEMENT OF Z-STAND COULD CAUSE SERIOUS INJURY OR DEATH:  
 • READ AND UNDERSTAND INSTRUCTIONS IN OPERATOR'S MANUAL PRIOR TO OPERATING Z-STAND.  
 • DO NOT OPERATE Z-STAND IF ANY PARTS ARE DAMAGED OR MISSING.  
 • SET ENGINE SPEED TO HALF-THROTTLE PRIOR TO ELEVATING MACHINE.  
 • SET PARKING BRAKE AND TURN OFF ENGINE PRIOR TO DISMOUNTING AND WORKING UNDER DECK.  
 • Z-STAND MUST BE PROPERLY STORED IN CRADLE WHILE MOWING AND TRANSPORTING.

104-7759

104-7759

**TORO** LANDSCAPE CONTRACTOR EQUIPMENT

**Mobil 1**

- 15 W 50 SYNTHETIC OIL
- LONGER HYDRAULIC LIFE
- LESS MAINTENANCE
- INCREASED PRODUCTIVITY

104-8172

104-8172

**WARNING**

OPERATE ONLY WITH DEFLECTOR OR CATCHER IN PLACE.  
 READ OPERATORS MANUAL.

104-8569

104-8569

MAINTENANCE FREE • SANS ENTRETIEN • LIBRE DE MANTENIMIENTO

NIVEAU MAXIMUM / NIVEAU MINIMUM / MAXIMUM FILL / MINIMUM FILL / CAPACIDAD MAXIMA / CAPACIDAD MINIMA

**DANGER/POISON ¡PELIGRO/VENENO!**

**1** Contains lead; do not discard.

**2** Recycle

**3** Wear eye protection; explosive gases can cause blindness and other injuries

**4** No sparks, flame, or smoking

**5** Sulfuric acid can cause blindness or severe burns.

**6** Flush eyes immediately with water and get medical help fast.

**7** Maximum fill line

**8** Minimum fill line

**9** Instructions for activating the battery

SHIELD EYES. EXPLOSIVE GASES CAN CAUSE BLINDNESS OR INJURY. PROTEGER LES YEUX. GAZ EXPLOSIFS PEUVENT RENDRE AVEUGLE OU PROVOQUER DES LESIONS. PROTEJA LOS OJOS. GASES EXPLOSIVOS PUEDEN CAUSAR CEGUERA O DAÑO.

NO SPARKS • FLAMES • SMOKING. ÉLOIGNER • ÉTINCELLES • FLAMMES • CIGARETTES. NO CHISPAS • FLAMAS • FUMAR.

SULFURIC ACID CAN CAUSE BLINDNESS OR SEVERE BURNS. ACIDE SULFURIQUE PEUT RENDRE AVEUGLE OU PROVOQUER DES BRULURES GRAVES. ACIDO SULFURICO PUEDE CAUSAR CEGUERA O QUEMADURAS SEVERAS.

FLUSH EYES IMMEDIATELY WITH WATER. GET MEDICAL HELP FAST. RINCER IMMEDIATEMENT LES YEUX A GRANDE EAU. CONTACTER RAPIDEMENT UN MEMBRE DE LA PROFESSION MEDICALE. LAVE LOS OJOS DE INMEDIATO. CONSIGA AYUDA MEDICA RAPIDO.

HOW TO ACTIVATE DRY CHARGED BATTERIES

1. Use only battery electrolyte (1.265 Sp. Gr.) to fill battery initially.
2. Do not overfill. Let stand for 15 minutes.
3. Charge battery at 4-5 amps until specific gravity is 1.250 or higher and temperature is at least 60°F. - all cells gassing freely.
4. After battery has been activated, add only water to replace normal loss.

KEEP OUT OF THE REACH OF CHILDREN. DO NOT TIP. DO NOT OPEN BATTERY! MANTENGASE FUERA DEL ALCANCE DE LOS NIÑOS. NO INCLINE. NO ABRA LA BATERIA!

Dist. by:/por:/par: The Toro Company, Bloomington, MN 55420 MADE IN U.S.A. • FABRIQUE AUX E.U.A. • HECHO EN E.U.A.

104-4164

1. Contains lead; do not discard.
2. Recycle
3. Wear eye protection; explosive gases can cause blindness and other injuries
4. No sparks, flame, or smoking
5. Sulfuric acid can cause blindness or severe burns.
6. Flush eyes immediately with water and get medical help fast.
7. Maximum fill line
8. Minimum fill line
9. Instructions for activating the battery

MOTION CONTROL

**CAUTION**

Mercury in tilt switch is poisonous and can cause severe illness.

- Never attempt to open or repair switch.
- Avoid contact with mercury.
- See operator's manual for disposal rules.

**WARNING**

Battery contains sulfuric acid. Avoid contact and always shield eyes, face, skin and clothing from battery. Cigarettes, flames or sparks could cause battery to explode. Do not charge or use booster cables or adjust post connections without proper training. In event of an accident flush with water and call a physician immediately. Keep out of reach of children.

103-2433

**DRIVE WHEEL RELEASE**

Use 5/8 wrench  
One turn counterclockwise to release  
Do not over-tighten

103-2433

DISENGAGE

ENGAGE

**BRAKE**

**WARNING**

To avoid serious injury or death:

- Read and understand the operator's manual before using this machine.
- Do not operate unless trained to safely use this machine.
- Do not operate under the influence of alcohol or drugs.
- Do not operate without shields, guards, and safety devices in place and working.
- Check the function of all safety interlocks daily.
- Do not defeat interlocks.
- Hearing protection is recommended.

For replacement manual, send model & serial number to: The Toro Co., 5111 Lyndale Ave. S., Bloomington, MN 55420.

**DANGER**

- Pick up objects that could be thrown by the blades.
- Never mow when bystanders are in the area.
- Never carry passengers.
- Look behind and to the side before changing directions.
- Stop the engine and remove key before adjusting, servicing or cleaning machine and attachments.

Before leaving the operator's position:

- Stop the engine and disengage the blade.
- Move the levers out to the neutral lock position.
- Set the parking brake.
- Avoid blades unless engine and blades are stopped.

**THROTTLE**

**IMPORTANT:** Before starting engine clean grass from pump drive belt compartment. Check more often in dry conditions.

106-6570

**⚠ DANGER**

- Mowing on wet grass or steep slopes can cause sliding and loss of control.
- Wheels dropping over edges can cause rollovers, which may result in serious injury, death or drowning.
- To avoid loss of control and possibility of rollover:
  - Do NOT mow near drop-offs or near water.
  - Do NOT mow slopes greater than 15°.
  - Reduce speed and use extreme caution on slopes.
  - Avoid sudden turns or rapid speed changes.
- A rollbar is available and its use is recommended for areas where there are slopes, drop-offs or water.

Greater than 15°

105-6571

106-6571

# Gasoline and Oil

## Recommended Gasoline

Use UNLEADED Regular Gasoline suitable for automotive use (85 pump octane minimum). Leaded regular gasoline may be used if unleaded regular is not available.

**Important** Never use methanol, gasoline containing methanol, or gasohol containing more than 10% ethanol because the fuel system could be damaged. Do not mix oil with gasoline.



### Danger



In certain conditions, gasoline is extremely flammable and highly explosive. A fire or explosion from gasoline can burn you and others and can damage property.

- Fill the fuel tank outdoors, in an open area, when the engine is cold. Wipe up any gasoline that spills.
- Never fill the fuel tank inside an enclosed trailer.
- Do not fill the fuel tank completely full. Add gasoline to the fuel tank until the level is 1/4 to 1/2 inch (6 to 13 mm) below the bottom of the filler neck. This empty space in the tank allows gasoline to expand.
- Never smoke when handling gasoline, and stay away from an open flame or where gasoline fumes may be ignited by a spark.
- Store gasoline in an approved container and keep it out of the reach of children. Never buy more than a 30-day supply of gasoline.
- Always place gasoline containers on the ground away from your vehicle before filling.
- Do not fill gasoline containers inside a vehicle or on a truck or trailer bed because interior carpets or plastic truck bed liners may insulate the container and slow the loss of any static charge.
- When practical, remove gas-powered equipment from the truck or trailer and refuel the equipment with its wheels on the ground.
- If this is not possible, then refuel such equipment on a truck or trailer from a portable container, rather than from a gasoline dispenser nozzle.
- If a gasoline dispenser nozzle must be used, keep the nozzle in contact with the rim of the fuel tank or container opening at all times until fueling is complete.



### Warning



Gasoline is harmful or fatal if swallowed. Long-term exposure to vapors can cause serious injury and illness.

- Avoid prolonged breathing of vapors.
- Keep face away from nozzle and gas tank or conditioner opening.
- Keep gas away from eyes and skin.

## Using Stabilizer/Conditioner

Use a fuel stabilizer/conditioner in the machine to provide the following benefits:

- Keeps gasoline fresh during storage of 90 days or less. For longer storage it is recommended that the fuel tank be drained.
- Cleans the engine while it runs
- Eliminates gum-like varnish buildup in the fuel system, which causes hard starting

**Important** Do not use fuel additives containing methanol or ethanol.

Add the correct amount of gas stabilizer/conditioner to the gas.

**Note:** A fuel stabilizer/conditioner is most effective when mixed with fresh gasoline. To minimize the chance of varnish deposits in the fuel system, use fuel stabilizer at all times.

## Filling the Fuel Tank

1. Shut the engine off and set the parking brake.
2. Clean around each fuel tank cap and remove the cap. Add unleaded regular gasoline to both fuel tanks, until the level is 1/4 to 1/2 inch (6 to 13 mm) below the bottom of the filler neck. This space in the tank allows gasoline to expand. Do not fill the fuel tanks completely full.
3. Install fuel tank caps securely. Wipe up any gasoline that may have spilled.

## Checking the Engine Oil Level

Before you start the engine and use the machine, check the oil level in the engine crankcase; refer to Checking the Oil Level, page 31.

# Setup

**Note:** Determine the left and right sides of the machine from the normal operating position.

## Loose Parts

**Note:** Use the chart below to verify all parts have been shipped.

DESCRIPTION	QTY.	USE
Rear wheels	2	Installing the wheels to the traction unit.
Suspension Seat	1	Install seat
Nut	4	
Control lever—right	1	Installing the motion control levers.
Control lever—left	1	
Bolt, 3/8 x 1 inch	4	
Spring washer, 3/8 inch	4	
Key	2	Read before operating the machine.
Operator's Manual	1	
Engine Operator's Manual	1	
Parts Catalog	1	
Registration card	1	Fill out and return to Toro.

## Installing the Drive Wheels

1. Uncrate the mower.
2. Remove the wheel nuts from the rear wheel hubs.
3. Align the holes. Mount the drive wheels with the valve stem to the outside of the traction unit.
4. Secure the wheels using the wheel nuts provided.  
Torque to 95 ft.-lb. (128 N·m).

## Checking the Tire Pressure

Check the air pressure in the front and rear tires (Fig. 2).

Pressure: 13 psi (90 kPa)

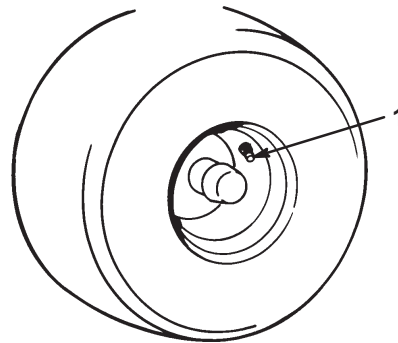

m-1872

**Figure 2**

1. Valve stem

# Installing the Seat

1. Remove seat from crate.
2. Position seat on the studs in the adjustable tracks (Fig. 3).
3. Install nuts onto studs (Fig 3).

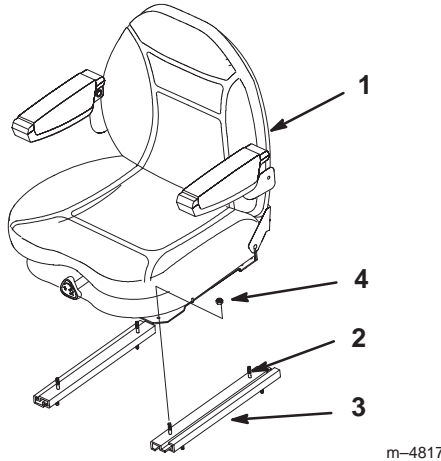

**Figure 3**

- |          |                     |
|----------|---------------------|
| 1. Seat  | 3. Adjustable track |
| 2. Studs | 4. Nuts             |

# Installing the Motion Control Levers

There are two positions to install the control levers: high and low. Install the levers in the top and middle holes for the high position. Install the levers in the middle and bottom holes for the low position.

1. Remove the 4 bolts (3/8 x 1 inch) and 4 spring washers (3/8 inch) which attach the motion control levers to the control arm shafts for shipping (Fig. 4).
2. Place the levers (with the mounting plate toward the rear) on the outside of the control arm shaft and secure them with 4 bolts (3/8 x 1 inch) and 4 spring washers (3/8 inch) (Fig. 4).
3. Position the lever so that the bolts are in the center of the slots on the lever mounting plate and tighten until snug.
4. Align the front/rear position of the levers, with each other, in the neutral position. Loosen the hardware and adjust by sliding/tilting the lever(s) forward or backward until they are properly aligned (Fig. 4).

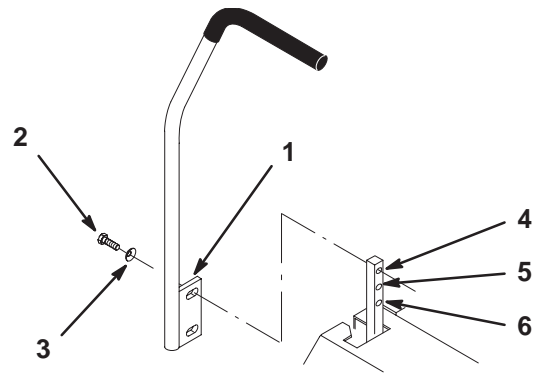

m-5596

**Figure 4**

- |                            |                |
|----------------------------|----------------|
| 1. Mounting plate          | 4. Top hole    |
| 2. Bolt, 3/8 x 1 inch      | 5. Middle hole |
| 3. Spring washer, 3/8 inch | 6. Bottom hole |

5. If the ends of the levers hit against each other while in the drive position (Fig. 5) (levers rotated in as far as possible), make adjustments by moving the levers outward to the neutral lock position and carefully bend them outward. Move them back to the drive position and check for clearance. Repeat if necessary.

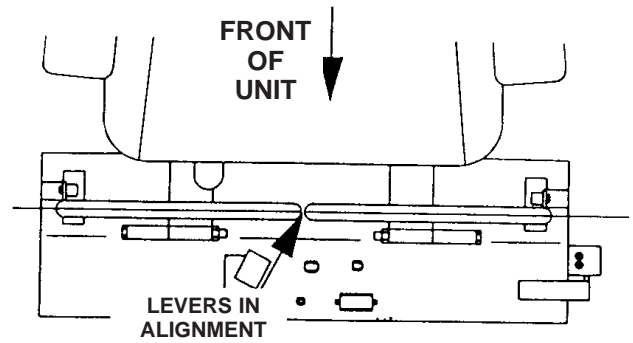

**Figure 5**

## Activating the Battery

Bulk electrolyte with 1.265 specific gravity must be purchased from a local battery supply outlet.

**Danger**

Battery electrolyte contains sulfuric acid which is a deadly poison and causes severe burns.

- Do not drink electrolyte and avoid contact with skin, eyes or clothing. Wear safety glasses to shield your eyes and rubber gloves to protect your hands.
- Fill the battery where clean water is always available for flushing the skin.
- Follow all instructions and comply with all safety messages on the electrolyte container.

1. Remove the battery from the machine; refer to Removing the Battery, page 48.
  2. Clean the top of the battery with a paper towel.
- Note:** Never fill the battery with electrolyte while the battery is installed in the machine. Electrolyte could be spilled on other parts and cause corrosion.
3. Remove the vent caps from the battery (Fig. 6).
  4. Slowly pour electrolyte into each battery cell until the level is up to the **upper** line (Fig. 6) on the battery case.

**Important** Do not overfill the battery because electrolyte (sulfuric acid) can cause severe corrosion and damage to the chassis.

5. Wait five to ten minutes after filling the battery cells. Add electrolyte, if necessary, until the electrolyte level is up to the **upper** line (Fig. 6) on the battery case.
6. Reinstall battery filler caps.

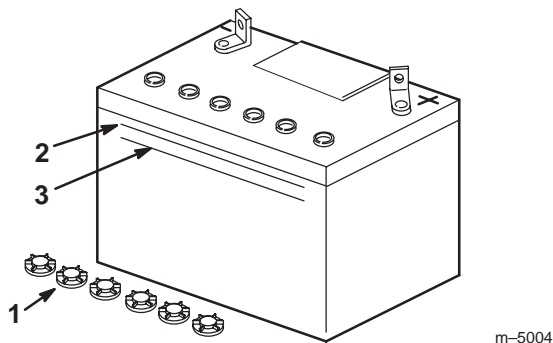

**Figure 6**

1. Filler caps
2. **Upper** line
3. **Lower** line

**Warning**

Charging battery produces gasses that can explode and cause serious injury.

- Keep cigarettes, sparks and flames away from battery.
- Make sure the ignition switch is off.
- Ventilate when charging or using battery in an enclosed space.

7. Charge the battery; refer to Charging the Battery, page 49.
8. Install the battery into the machine; refer to Installing the Battery, page 47.

**Note:** Do not run the machine with the battery disconnected, electrical damage may occur.

## Checking the Engine Oil Level

Before you start the engine and use the machine, check the oil level in the engine crankcase; refer to Checking the Oil Level, page 31.

## Checking the Side Discharge Chute

Remove the plastic tie holding the side discharge chute up and lower it into place.

## Checking the Leveling of the Mower Deck

Check the level of the deck before the machine is first put in use.

Refer to Adjusting the Mower Level, page 42.

## Checking the Radiator Coolant

Check the cooling system level before the engine is first started.

Refer to Checking the Radiator Coolant, page 32.

## Greasing the Bearings

**Important** Make sure that the cutting unit spindles are full of grease before the engine is first started.

Grease with No. 2 general purpose lithium base or molybdenum base grease.



Grease the fittings on the three spindle bearings. Grease until it comes out of the lower seals (Fig. 7).

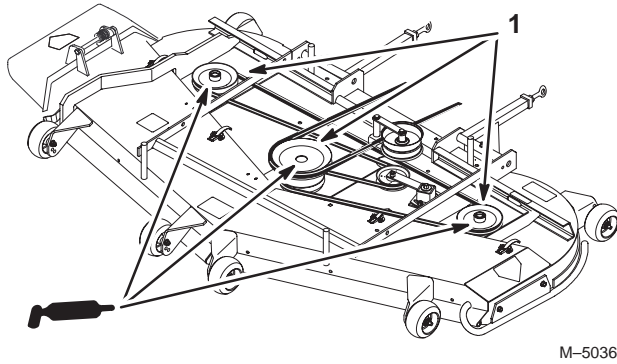

M-5036

Figure 7

1. Spindles

## Checking the Hydraulic Fluid

Check the hydraulic fluid level before the engine is first started; refer to Checking the Hydraulic Fluid, page 37.

## Operation

**Note:** Determine the left and right sides of the machine from the normal operating position.

## Think Safety First

Please read all safety instructions and symbols in the safety section. Knowing this information could help you or bystanders avoid injury.

! **Danger** !

**Mowing on wet grass or steep slopes can cause sliding and loss of control.**

**Wheels dropping over edges can cause rollovers, which may result in serious injury, death or drowning.**

**A rollbar is available and its use is recommended for areas where there are slopes, drop-offs or water.**

**To avoid loss of control and possibility of rollover:**

- **Do not mow near drop-offs or near water.**
- **Do not mow slopes greater than 15 degrees.**
- **Reduce speed and use extreme caution on slopes.**
- **Avoid sudden turns or rapid speed changes.**

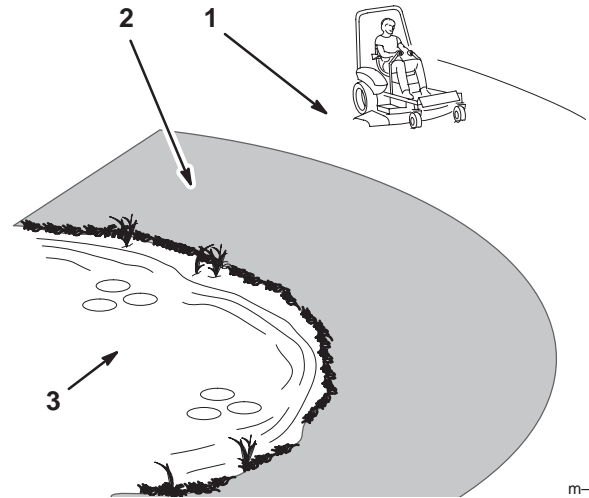

m-6478

Figure 8

1. Safe Zone—use the Z Master here on slopes less than 15 degrees or flat areas.
2. Use walk behind mower and/or hand trimmer near drop-offs and water.
3. Water

The use of protective equipment for eyes, ears, feet, and head is recommended.

! **Caution** !

**This machine produces sound levels in excess of 85 dBA at the operators ear and can cause hearing loss through extended periods of exposure.**

**Wear hearing protection when operating this machine.**



Figure 9

1. Warning—wear hearing protection.

## Controls

Become familiar with all the controls (Fig. 10) before you start the engine and operate the machine.

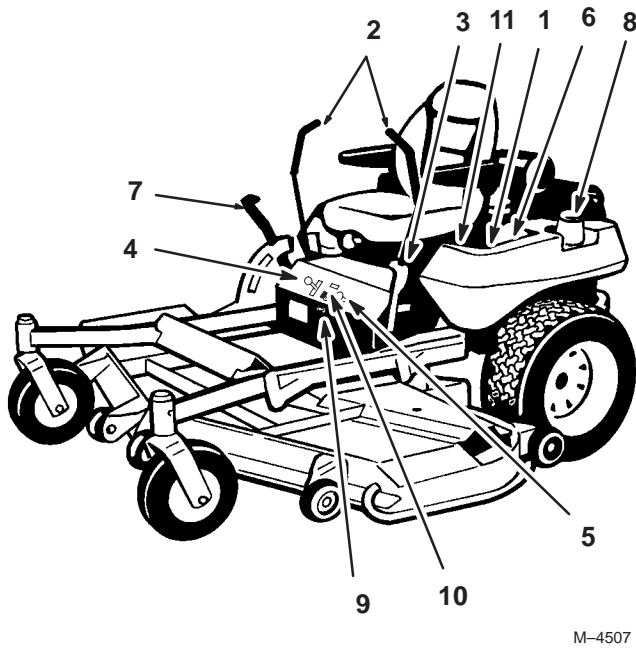

Figure 10

- |                         |                        |
|-------------------------|------------------------|
| 1. Ignition switch      | 7. Height-of-Cut lever |
| 2. Motion control lever | 8. Fuel cap            |
| 3. Parking brake lever  | 9. Fuel shut off lever |
| 4. Throttle             | 10. Hour meter         |
| 5. Choke                | 11. Temperature Gauge  |
| 6. Power take off (PTO) |                        |

## Hour Meter

The hour meter records the number of hours the engine has operated. It operates when the engine is running. Use these times for scheduling regular maintenance.

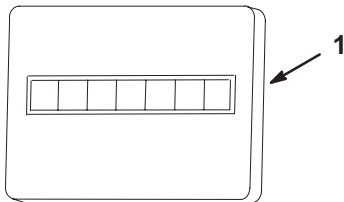

Figure 11

1. Hour meter

## Switching the Fuel Tanks

The unit has two fuel tanks, one located on the left side and on the right side. Each tank connects to the fuel shut off valve in the control panel. From there a common fuel line leads to the engine (Fig. 12).

To use the right side fuel tank, rotate the fuel shut off valve 1/4 turn to the right from the off location. This uses fuel from the right side tank only. When the right hand fuel tank is empty, move the fuel shut off valve 1/4 turn to the left from the off position.

Close the fuel shut off valve, on the front panel, before transporting or storing the machine.

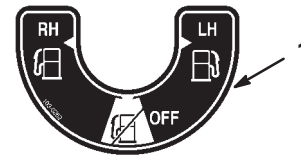

Figure 12

1. Shut off valve

## Operating the Parking Brake

Always set the parking brake when you stop the machine or leave it unattended.

## Setting the Parking Brake

1. Move the motion control levers (Fig. 10) out to the neutral lock position.
2. Pull back and up on the parking brake lever to set the parking brake (Fig. 13). The parking brake lever should stay firmly in the Engaged position.

! **Warning** !

**Parking brake may not hold machine parked on a slope and could cause personal injury or property damage.**

**Do not park on slopes unless wheels are chocked or blocked**

## Releasing the Parking Brake

Push forward and down on the parking brake lever to release the parking brake (Fig. 13). The parking brake is disengaged and the lever rests against the brake stop.

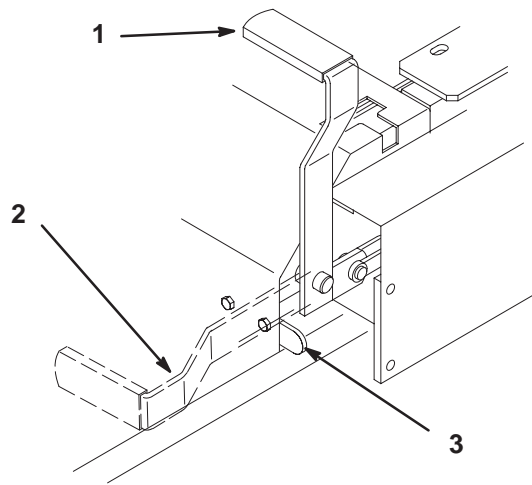

**Figure 13**

1. Parking brake—ON
2. Parking brake—OFF
3. Brake stop

## Starting and Stopping the Engine

### Starting the Engine

1. Sit on the seat and move the motion controls to the neutral locked position.
2. Set the parking brake; refer to Setting the Parking Brake, page 18.
3. Move the PTO (power take off) switch to Off (Fig. 14).
4. Move the choke control to the On position before starting a cold engine (Fig. 15).

**Note:** A warm or hot engine may not require choking. After engine starts, move the choke control to the Run position.

5. Move the throttle control to the Fast position before starting a cold engine (Fig. 16).
6. Turn the ignition key to Start to energize the starter. When the engine starts, release the key (Fig. 17).

**Important** Do not engage the starter for more than 10 seconds at a time. If the engine fails to start, allow a 30 second cool-down period between attempts. Failure to follow these instructions can burn out the starter motor.

7. After the engine starts, move the choke to Off (Fig. 15). If the engine stalls or hesitates, move the choke back to On for a few seconds. Then move the throttle lever to the desired setting. Repeat this as required.

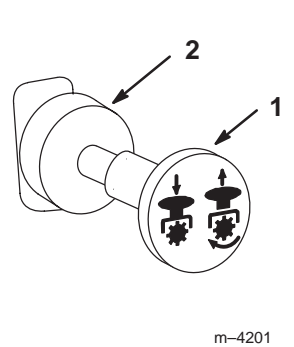

m-4201

**Figure 14**

1. PTO—On
2. PTO—Off

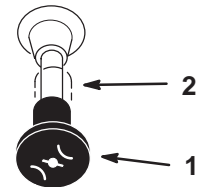

m-2719

**Figure 15**

1. Choke—On
2. Choke—Off

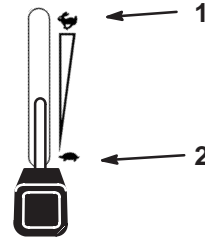

m-2720

**Figure 16**

1. Throttle—Fast
2. Throttle—Slow

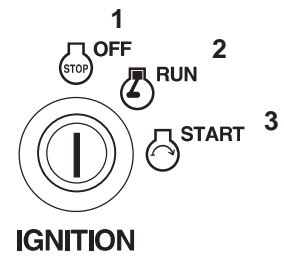

M-4268

**Figure 17**

1. Off
2. Run
3. Start

### Stopping the Engine

1. Push the PTO to off (Fig. 16).
2. Move the throttle lever midway between the slow and fast positions (Fig. 16).
3. Let the engine idle for 60 seconds (Fig. 17).
4. Turn the ignition key to off (Fig. 17).
5. Pull wire off spark plug(s) to prevent possibility of someone accidentally starting the machine before transporting or storing machine.
6. Close fuel shut off valve, on front panel before transporting or storing machine.

**Important** Make sure that the fuel shut off valve is closed before transporting or storing the machine, as fuel leakage may occur. Set the parking brake before transporting. Make sure to remove the key as the fuel pump may run and cause the battery to lose charge.

**Caution**

Children or bystanders may be injured if they move or attempt to operate the tractor while it is unattended.

Always remove the ignition key and set the parking brake when leaving the machine unattended, even if just for a few minutes.

## Operating the Power Take Off (PTO)

The power take off (PTO) switch engages and disengages power to the electric clutch.

### Engaging the PTO

1. While seated in the seat, release the pressure on the traction control levers and place in neutral.
2. Place the throttle in the fast position.
3. Pull out on the power take off (PTO) switch to engage it (Fig. 18).

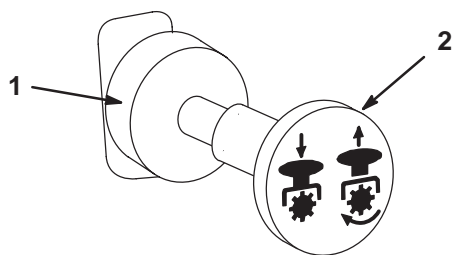

Figure 18

m-4201

1. PTO—Off

2. PTO—On

## Disengaging the PTO

1. To disengage, push the PTO switch to the Off position (Fig. 18).

## The Safety Interlock System

**Caution**

If safety interlock switches are disconnected or damaged the machine could operate unexpectedly causing personal injury.

- Do not tamper with the interlock switches.
- Check the operation of the interlock switches daily and replace any damaged switches before operating the machine.

### Understanding the Safety Interlock System

The safety interlock system is designed to prevent the engine from starting unless:

- You are sitting on the seat.
- The parking brake is engaged.
- The power take off (PTO) is disengaged.
- The motion control levers are in the neutral locked position.

The safety interlock system also is designed to stop the engine when the traction controls are moved from the locked position with the parking brake on **engaged** or if you rise from the seat when the PTO is **on** or engaged.

### Testing the Safety Interlock System

Test the safety interlock system before you use the machine each time. If the safety system does not operate as described below, have an Authorized Service Dealer repair the safety system immediately.

1. Sitting on the seat, engage the parking brake, and move the PTO On. Try starting the engine; the engine should not crank.
2. Sitting on the seat, engage the parking brake, and move the PTO to Off. Move either motion control lever (out of neutral locked position). Try starting the engine; the engine should not crank. Repeat for the other control lever.
3. Sitting on the seat, engage the parking brake, move the PTO to Off, and lock the motion control levers in neutral. Now start the engine. While the engine is running, release the parking brake, engage the PTO, and rise slightly from the seat; the engine should stop.

4. Sitting on the seat, engage the parking brake, move the PTO to Off, and lock the motion control levers in to neutral. Now start the engine. While the engine is running, center either motion control and move (forward or reverse); the engine should stop. Repeat for the other motion control.
5. Sitting on the seat, disengage the parking brake, move the PTO switch to Off, and move the motion control levers to the neutral lock position. Try starting the engine; the engine should not crank.

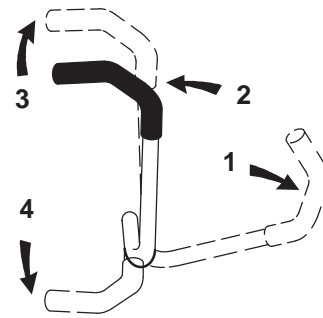

m-2715

**Figure 19**

- |   |                           |
|---|---------------------------|
| 1. Motion control lever—neutral lock position | 2. Center unlock position |
|   | 3. Forward                |
|   | 4. Backward               |

## Driving Forward or Backward

The throttle control regulates the engine speed as measured in RPM (revolutions per minute). Place the throttle control in the Fast position for best performance. Always operate in the full throttle position when mowing.

! **Caution** !

**Machine can spin very rapidly. Operator may lose control of machine and cause personal injury or damage to machine.**

- Use caution when making turns.
- Slow the machine down before making sharp turns.

### Driving Forward

1. Release the parking brake; refer to Releasing the Parking Brake, page 18.
2. Move the levers to the center, unlocked position.
3. To go forward, slowly push the motion control levers forward (Fig. 19).

**Note:** The engine will kill if the traction control levers are moved with the parking brake engaged.

To go straight, apply equal pressure to both motion control levers (Fig. 19).

To turn, move the motion control lever toward neutral in the direction you want to turn (Fig. 19).

The farther you move the traction control levers in either direction, the faster the machine will move in that direction.

To stop, pull the motion control levers to neutral.

### Driving Backward

1. Move the levers to the center, unlocked position.
2. To go backward, slowly pull the motion control levers rearward (Fig. 19).

To go straight, apply equal pressure to both motion control levers (Fig. 19).

To turn, release pressure on the motion control lever toward the direction you want to turn (Fig. 19).

To stop, push the motion control levers to neutral.

## Stopping the Machine

To stop the machine, move the traction control levers to neutral and move to locked position, disengage the power take off (PTO), and turn the ignition key to off. Also set the parking brake when you leave the machine; refer to Setting the Parking Brake, page 18. Remember to remove the key from the ignition switch.

! **Caution** !

**Children or bystanders may be injured if they move or attempt to operate the tractor while it is unattended.**

**Always remove the ignition key and set the parking brake when leaving the machine unattended, even if just for a few minutes.**

## Adjusting the Height-of-Cut

The height-of-cut is adjusted from 1-1/2 to 5 inch (38 to 127 mm) in 1/4 inch (6 mm) increments by relocating the clevis pin in different hole locations.

1. Raise the height-of-cut lever to the transport position (also the 5 inch [127 mm] cutting height position) (Fig. 20).
2. To adjust, remove the hairpin cotter and clevis pin from the height-of-cut bracket (Fig. 20).
3. Select the hole in the height-of-cut bracket corresponding to the height-of-cut desired, and insert the clevis pin (Fig. 20).
4. Secure the clevis pin with the hairpin cotter (Fig. 20).
5. Move the lever to the selected height.

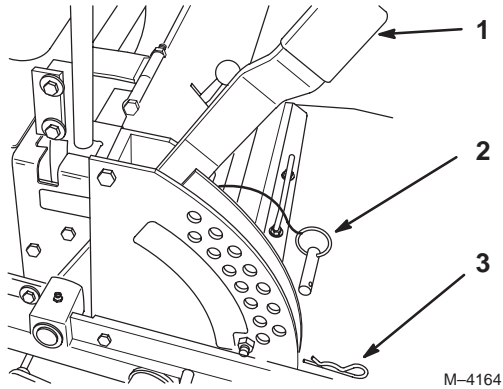

**Figure 20**

1. Height of cut lever
2. Clevis pin
3. Hairpin cotter

## Adjusting the Anti-Scalp Rollers

Whenever you change the height-of-cut it is recommended to adjust the height of the anti-scalp rollers.

1. Disengage the power take off (PTO) and turn the ignition key to off. Move the control levers to the neutral locked position and apply the parking brake. Remove the key.
2. After adjusting the height-of-cut, remove the flange nut and spring disk while holding the stud with a wrench (Fig. 21).

**Note:** Do not remove the wheel nut and washer (Fig. 21).

3. Select a hole so that the gage wheel is positioned to the nearest corresponding height-of-cut desired (Fig. 21).
4. Reinstall the flange nut and spring disk (Fig. 21).
5. Repeat the adjustment on the other gage wheels.

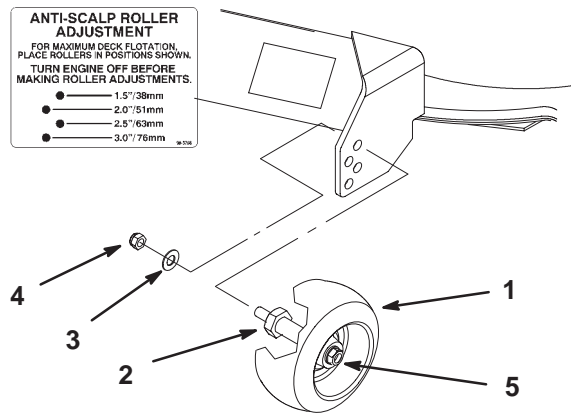

**Figure 21**

1. Gage wheel
2. Stud
3. Spring disk
4. Flange nut
5. Wheel nut and washer. Do not remove.

## Positioning the Seat

### Changing the Seat Position

The seat can move forward and backward. Position the seat where you have the best control of the machine and are most comfortable.

1. To adjust, move the lever sideways to unlock seat (Fig. 22).
2. Slide the seat to the desired position and release lever to lock in position.

### Changing the Seat Suspension

The seat can be adjusted to provide a smooth and comfortable ride. Position the seat where you are most comfortable.

1. To adjust, turn the knob in front either direction to provide the best comfort (Fig. 22).

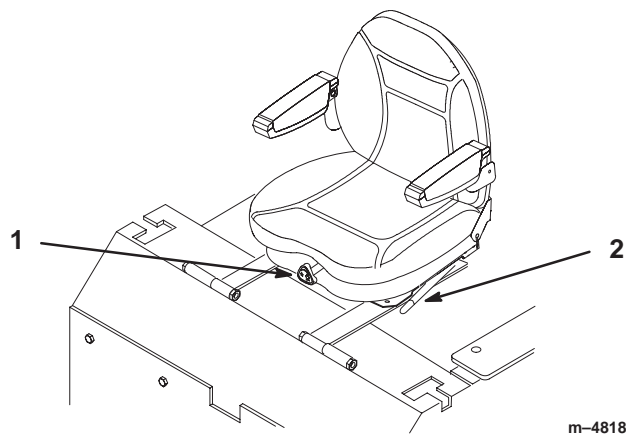

**Figure 22**

1. Seat suspension knob
2. Seat position adjustment

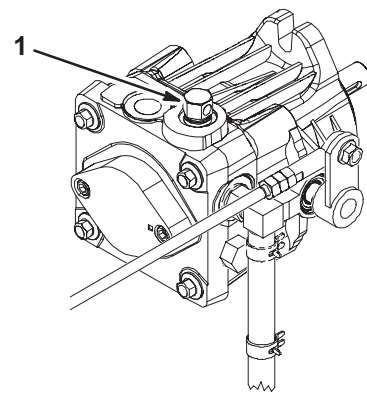

**Figure 23**

1. By-pass valve

## Pushing the Machine by Hand

**Important** Always push the machine by hand. Never tow the machine because hydraulic damage may occur.

### To Push the Machine

1. Disengage the power take off (PTO) and turn the ignition key to off. Move the levers to the neutral locked position and apply the parking brake.
2. Rotate the by-pass valves counterclockwise 1 turn to push. This allows hydraulic fluid to by-pass the pump enabling the wheels to turn (Fig. 23).

**Important** Do not rotate the by-pass valves more than 1 turn. This prevents the valves from coming out of the body and causing fluid to run out.

3. Disengage the parking brake before pushing.

## Changing to Machine Operation

Rotate the by-pass valves clockwise 1 turn to operate the machine (Fig. 23).

**Note:** Do not over tighten the by-pass valves.

**Note:** The machine will not drive unless the by-pass valves are turned in.

## Using a Rollover Protection System (ROPS)

A ROPS is available and its use is recommended for areas where there are slopes, drop-offs or water. Contact an Authorized Service Dealer for information on obtaining ROPS for your machine.

**Important** When operating a machine with ROPS always use the seat belt.

## Transporting the Machine

Use a heavy-duty trailer or truck to transport the machine. Ensure that the trailer or truck has all necessary lighting and marking as required by law. Please carefully read all the safety instructions. Knowing this information could help you, your family, pets, or bystanders avoid injury.

To transport the machine:

- Lock the brake and block the wheels.
- Securely fasten the machine to the trailer or truck with straps, chains, cable, or ropes.
- Secure a trailer to the towing vehicle with safety chains.



### Warning



**Driving on street or roadway without turn signals, lights, reflective markings, or a slow moving vehicle emblem is dangerous and can lead to accidents causing personal injury.**

**Do not drive machine on a public street or roadway.**

## Loading Machines

Use extreme caution when loading units on trailers or trucks. One full width ramp that is wide enough to extend beyond the rear tires is recommended instead of individual ramps for each side of the unit (Fig. 24). The lower rear section of the tractor frame extends back between the rear wheels and serves as a stop for tipping backward. Having a full width ramp provides a surface for the frame members to contact if the unit starts to tip backward. If it is not possible to use one full width ramp, use enough individual ramps to simulate a full width continuous ramp.

The ramp should be long enough so that the angles do not exceed 15 degrees (Fig. 24). A steeper angle may cause mower deck components to get caught as the unit moves from ramp to trailer or truck. Steeper angles may also cause the unit to tip backward. If loading on or near a slope, position the trailer or truck so it is on the down side of the slope and the ramp extends up the slope. This will minimize the ramp angle. The trailer or truck should be as level as possible.

**Important** Do Not attempt to turn the unit while on the ramp; you may lose control and drive off the side.

Avoid sudden acceleration when driving up a ramp and sudden deceleration when backing down a ramp. Both maneuvers can cause the unit to tip backward.

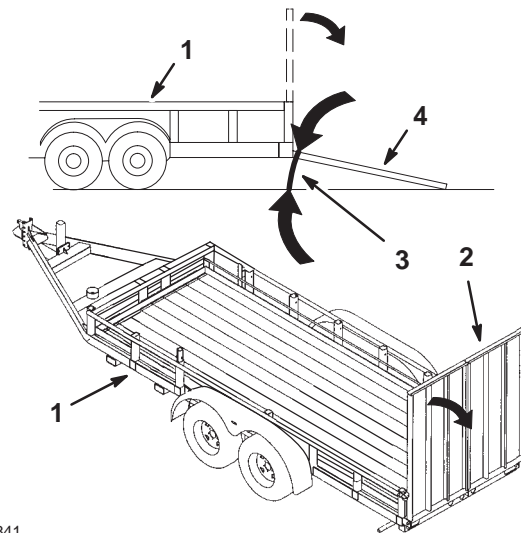

m-6841

Figure 24

1. Trailer
2. Full width ramp
3. Not greater than 15 degrees
4. Full width ramp—side view



### Warning



Loading a unit onto a trailer or truck increases the possibility of backward tip-over and could cause serious injury or death.

- Use extreme caution when operating a unit on a ramp.
- Use only a single, full width ramp; DO NOT use individual ramps for each side of the unit.
- If individual ramps must be used, use enough ramps to create an unbroken ramp surface wider than the unit.
- Do not exceed a 15 degree angle between ramp and ground or between ramp and trailer or truck.
- Avoid sudden acceleration while driving unit up a ramp to avoid tipping backward.
- Avoid sudden deceleration while backing unit down a ramp to avoid tipping backward.



### Warning



Unit could fall onto someone and cause serious injury or death.

- Use extreme caution when operating unit on Z Stand.
- Use only for cleaning deck and removing blades.
- Do not keep unit on Z Stand for extended periods of time.
- Always shut engine off and set parking brake before performing any maintenance to deck.

## Driving up onto the Z Stand

**Important** Use the Z Stand on a level surface.

1. Raise the deck to the transport position.



- Remove the bracket pin (Fig. 25).

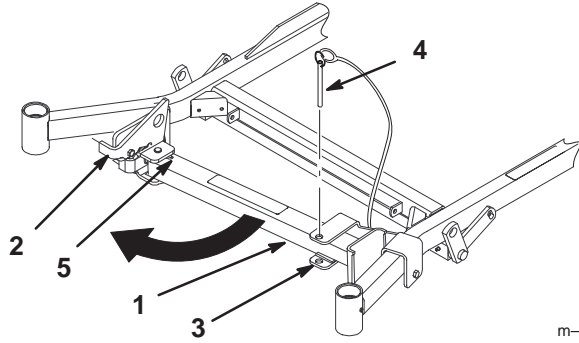

**Figure 25**

- |            |                   |
|------------|-------------------|
| 1. Z Stand | 4. Bracket pin    |
| 2. Latch   | 5. Bottom of slot |
| 3. Bracket |                   |

- Raise the latch. Swing the stand foot out front and slide the stand toward the machine, into the bottom of the slot (Fig. 25 and 26).
- Set the foot of the stand on the ground and rest the latch on the pivot tab (Fig. 26).

- Start the engine and put it at half throttle.

**Note:** For best results, place the foot of the stand into seams in sidewalks or into turf (Fig. 26).

- Drive onto the stand. Stop when the latch drops over the tab into the locked position (Fig. 26). Once onto the stand, engage the parking brake. Shut off the engine.
- Chock or block the drive wheels.

⚠
Warning
⚠

**Parking brake may not hold machine parked on Z Stand and could cause personal injury or property damage.**

**Do not park on Z Stand unless wheels are chocked or blocked.**

- Perform the maintenance.
- Remove the chocks or blocks.

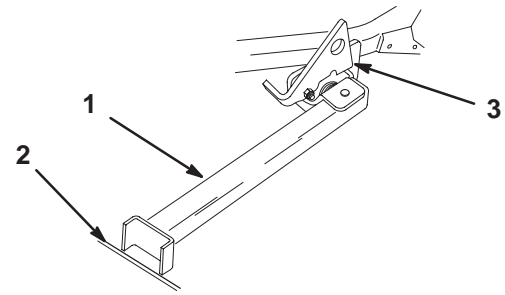
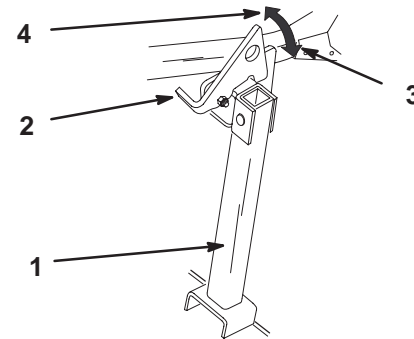

**Figure 26**

- |                                 |                               |
|---------------------------------|-------------------------------|
| 1. Z Stand (positioned in slot) | 2. Crack in side walk or turf |
|                                 | 3. Latch resting on pivot tab |

### Driving off of the Z Stand

- Raise the latch to the unlocked position (Fig. 27).
- Start the engine and place it at half throttle. Disengage the parking brake.
- Slowly drive backwards off of the stand.
- Return the stand to its rest position (Fig. 25).



**Figure 27**

- |            |                      |
|------------|----------------------|
| 1. Z Stand | 3. Locked position   |
| 2. Latch   | 4. Unlocked position |

### Using the Lift Assist Lever

The lift assist lever is used along with the height-of-cut lever for raising the deck. This allows for easier raising of the deck.

- Place your foot onto the lift assist lever.
- Press on the lift assist while pulling up on the height-of-cut lever (Fig. 28).

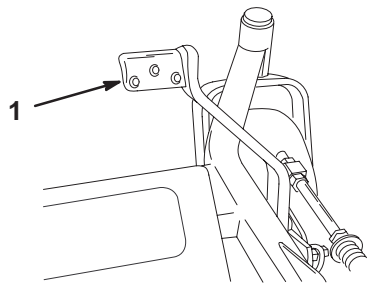

m-5028

Figure 28

1. Lift assist lever

## Tips for Mowing Grass

### Fast Throttle Setting

For best mowing and maximum air circulation, operate the engine at **fast**. Air is required to thoroughly cut grass clippings, so do not set the height-of-cut so low as to totally surround the mower by uncut grass. Always try to have one side of the mower free from uncut grass, which allows air to be drawn into the mower.

### Cutting a Lawn for the First Time

Cut grass slightly longer than normal to ensure that the cutting height of the mower does not scalp any uneven ground. However, the cutting height used in the past is generally the best one to use. When cutting grass longer than 6 inches (15 cm) tall, you may want to cut the lawn twice to ensure an acceptable quality of cut.

### Cut 1/3 of the Grass Blade

It is best to cut only about 1/3 of the grass blade. Cutting more than that is not recommended unless grass is sparse, or it is late fall when grass grows more slowly.

### Mowing Direction

Alternate mowing direction to keep the grass standing straight. This also helps disperse clippings which enhances decomposition and fertilization.

### Mow at Correct Intervals

Normally, mow every four days. But remember, grass grows at different rates at different times. So to maintain the same cutting height, which is a good practice, mow more often in early spring. As the grass growth rate slows in mid summer, mow less frequently. If you cannot mow for an extended period, first mow at a high cutting height; then mow again two days later at a lower height setting.

## Cutting Speed

To improve cut quality, use a slower ground speed in certain conditions.

## Avoid Cutting Too Low

If the cutting width of the mower is wider than the mower you previously used, raise the cutting height to ensure that uneven turf is not cut too short.

## Long Grass

If the grass is ever allowed to grow slightly longer than normal, or if it contains a high degree of moisture, raise the cutting height higher than usual and cut the grass at this setting. Then cut the grass again using the lower, normal setting.

## When Stopping

If the machine's forward motion must be stopped while mowing, a clump of grass clippings may drop onto your lawn. To avoid this, move onto a previously cut area with the blades engaged.

## Keep the Underside of the Mower Clean

Clean clippings and dirt from the underside of the mower after each use. If grass and dirt build up inside the mower, cutting quality will eventually become unsatisfactory.

## Blade Maintenance

Maintain a sharp blade throughout the cutting season because a sharp blade cuts cleanly without tearing or shredding the grass blades. Tearing and shredding turns grass brown at the edges, which slows growth and increases the chance of disease. Check the cutter blades daily for sharpness, and for any wear or damage. File down any nicks and sharpen the blades as necessary. If a blade is damaged or worn, replace it immediately with a genuine Toro replacement blade.

# Maintenance

**Note:** Determine the left and right sides of the machine from the normal operating position.

## Recommended Maintenance Schedule

Maintenance Service Interval	Maintenance Procedure
After first use	<ul style="list-style-type: none"> <li>• Check hydraulic fluid level</li> <li>• Change engine oil</li> <li>• Change hydraulic filter</li> </ul>
Each Use	<ul style="list-style-type: none"> <li>• Check engine oil level</li> <li>• Check safety system</li> <li>• Clean engine cooling system<sup>1</sup></li> <li>• Clean mower housing</li> <li>• Check engine coolant</li> </ul>
Every 5 Hours	<ul style="list-style-type: none"> <li>• Check cutting blades</li> <li>• Grease blade spindle bearings</li> </ul>
Every 25 Hours	<ul style="list-style-type: none"> <li>• Check hydraulic fluid level</li> <li>• Grease chassis<sup>1</sup></li> <li>• Oil linkage bushings<sup>1</sup></li> <li>• Check battery electrolyte</li> </ul>
Every 50 Hours	<ul style="list-style-type: none"> <li>• Service air cleaner<sup>1</sup></li> <li>• Check belts for wear/cracks</li> <li>• Check tire pressure</li> <li>• Service the spark arrester</li> </ul>
Every 100 Hours	<ul style="list-style-type: none"> <li>• Replace paper air cleaner<sup>1</sup></li> <li>• Change spark plug(s)</li> <li>• Check hydraulic lines</li> <li>• Change engine oil<sup>1</sup></li> <li>• Check fuel system</li> <li>• Check cooling system hoses</li> </ul>
Every 200 Hours	<ul style="list-style-type: none"> <li>• Change oil filter<sup>1</sup></li> <li>• Replace fuel filter</li> <li>• Check engine cooling system</li> <li>• Replace hydraulic filter</li> </ul>
Every 400 Hours	<ul style="list-style-type: none"> <li>• Change engine coolant</li> </ul>
Every 500 Hours or at Storage	<ul style="list-style-type: none"> <li>• Adjust caster pivot</li> <li>• Adjust wheel hub slotted nut</li> </ul>
Before Storage Service	<ul style="list-style-type: none"> <li>• Charge battery, disconnect cables</li> <li>• Drain gasoline</li> <li>• Paint chipped surfaces</li> <li>• Perform all maintenance procedures listed above before storage</li> </ul>

<sup>1</sup>More often in dusty, dirty conditions

**Important** Refer to your engine operator's manual for additional maintenance procedures.



## Caution



If you leave the key in the ignition switch, someone could accidentally start the engine and seriously injure you or other bystanders.

Remove the key from the ignition and disconnect the wire from the spark plug(s) before you do any maintenance. Set the wire aside so that it does not accidentally contact the spark plug.

## Servicing the Cutting Blades

Maintain sharp blades throughout the cutting season because sharp blades cut cleanly without tearing or shredding the grass blades. Tearing and shredding turns grass brown at the edges, which slows growth and increases the chance of disease.

Check the cutter blades daily for sharpness, and for any wear or damage. File down any nicks and sharpen the blades as necessary. If a blade is damaged or worn, replace it immediately with a genuine Toro replacement blade. For convenient sharpening and replacement, you may want to keep extra blades on hand.

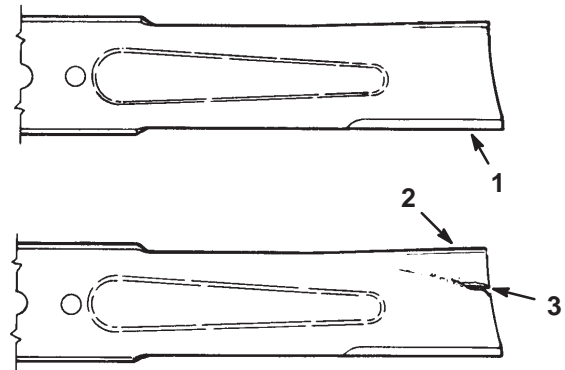

m-151

Figure 29

1. Cutting edge
2. Curved area
3. Wear/slot forming



## Danger



A worn or damaged blade can break, and a piece of the blade could be thrown into the operator's or bystander's area, resulting in serious personal injury or death.

- Inspect the blade periodically for wear or damage.
- Replace a worn or damaged blade.

## Checking for Bent Blades

1. Rotate the blades until the ends face forward and backward (Fig. 30). Measure from a level surface to the cutting edge of the blades (Fig. 31). Note this dimension.

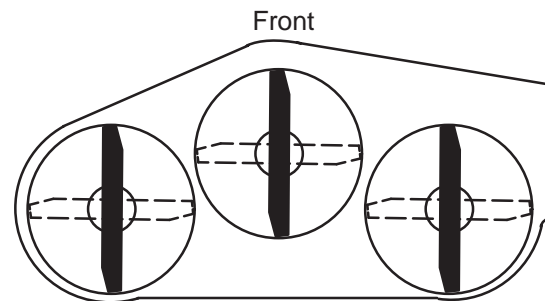

m-1078

Figure 30

## Before Inspecting or Servicing the Blades

Park the machine on a level surface, disengage the blade control (PTO), and set the parking brake. Turn the ignition key to off. Remove the key and disconnect the spark plug wire(s) from the spark plug(s).

## Inspecting the Blades

1. Inspect the cutting edges (Fig. 29). If the edges are not sharp or have nicks, remove and sharpen the blades; refer to Sharpening the Blades, page 29.
2. Inspect the blades, especially the curved area (Fig. 29). If you notice any damage, wear, or a slot forming in this area (item 3 in Fig. 29), immediately install a new blade.

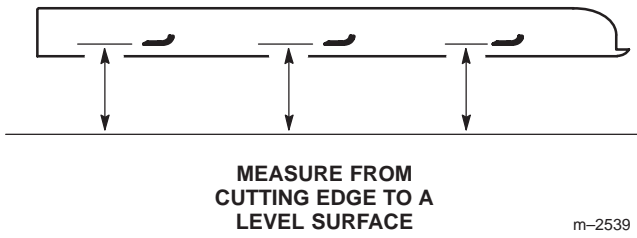

**Figure 31**

m-2539

2. Rotate the opposite ends of the blades forward.
3. Measure from a level surface to the cutting edge of the blades at the same position as in step 1 above. The difference between the dimensions obtained in steps 1 and 2 must not exceed 1/8 inch (3 mm). If this dimension exceeds 1/8 inch (3 mm), the blade is bent and must be replaced; refer to Removing the Blades and Installing the Blades, page 30.

**Warning**

**A blade that is bent or damaged could break apart and could seriously injure or kill you or bystanders.**

- Always replace bent or damaged blade with a new blade.
- Never file or create sharp notches in the edges or surfaces of blade.

### Removing the Blades

The blades must be replaced if a solid object is hit, if the blade is out of balance, or is bent. To ensure optimum performance and continued safety conformance of the machine, use genuine Toro replacement blades. Replacement blades made by other manufacturers may result in non-conformance with safety standards.

**Warning**

**Contact with sharp blade can cause serious injury.**

**Wear gloves or wrap sharp edges of the blade with a rag.**

Hold the blade end using a rag or thickly-padded glove. Remove the blade bolt, spring disk, and blade from the spindle shaft (Fig. 32).

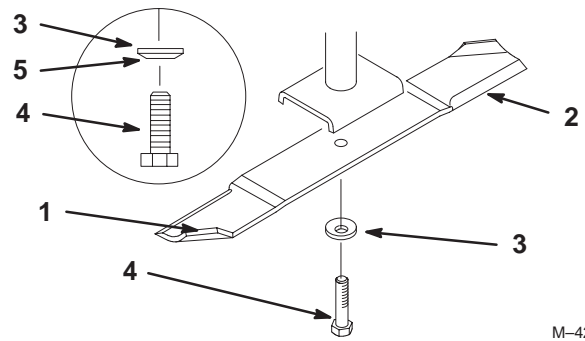

**Figure 32**

M-4226

1. Sail area of blade
2. Blade
3. Spring disk
4. Blade bolt
5. Cone toward bolt head

### Sharpening the Blades

**Warning**

**When sharpening blade, pieces of blade could be thrown and cause serious injury.**

**Wear proper eye protection when sharpening blade.**

1. Use a file to sharpen the cutting edge at both ends of the blade (Fig. 33). Maintain the original angle. The blade retains its balance if the same amount of material is removed from both cutting edges.

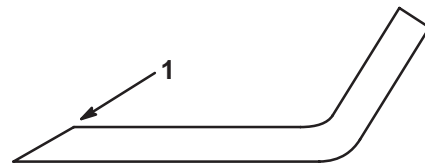

**Figure 33**

m-1854

1. Sharpen at original angle
2. Check the balance of the blade by putting it on a blade balancer (Fig. 34). If the blade stays in a horizontal position, the blade is balanced and can be used. If the blade is not balanced, file some metal off of the end of the sail area only (Fig. 32). Repeat this procedure until the blade is balanced.

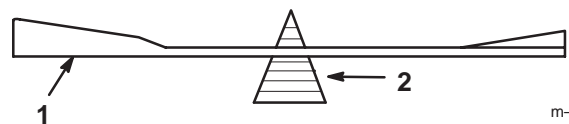

**Figure 34**

m-1855

1. Blade
2. Balancer

## Installing the Blades

1. Install the blade onto the spindle shaft (Fig. 32).

**Important** The curved part of the blade must be pointing upward toward the inside of the mower to ensure proper cutting.

2. Install the spring disk and blade bolt. The spring disk cone must be installed toward the bolt head. (Fig. 32).  
**Torque the blade bolt to 85–110 ft.-lb. (115–150 N·m).**

## Servicing the Air Cleaner

Paper Element:

- Clean after 50 operating hours.
- Replace after 300 operating hours.

**Note:** Service the air cleaner more frequently (every few hours) if operating conditions are extremely dusty or sandy.

### Removing the Paper Element

1. Disengage the power take off (PTO), set the parking brake, stop the engine, and remove the key.
2. Tilt the seat up and tilt the engine cover forward.
3. Clean around the air cleaner to prevent dirt from getting into the engine and causing damage. Loosen the retaining clips and remove the air cleaner cover (Fig. 35).

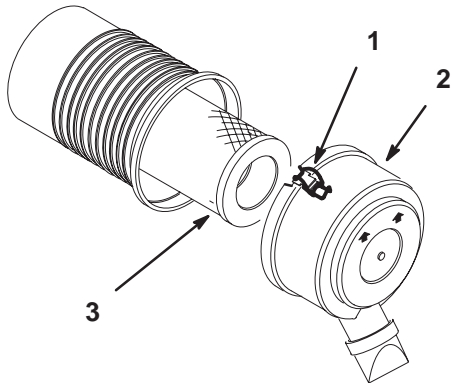

**Figure 35**

1. Retaining clip
2. Air cleaner cover
3. Air filter

4. Carefully remove the filter from the compartment (Fig. 35).

## Cleaning the Paper Elements

1. Lightly tap the element on a flat surface to remove dust and dirt (Fig. 36).
2. Inspect the element for tears, an oily film, and damage to the rubber seal.

**Important** Never clean the paper element with pressurized air or liquids, such as solvent, gas, or kerosene. Replace the paper element if it is damaged, or cannot be cleaned thoroughly.

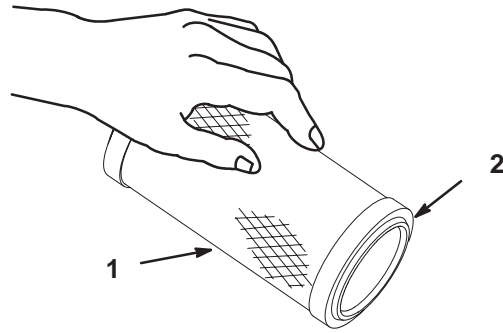

**Figure 36**

1. Paper element
2. Rubber seal

M-4383

## Installing the Paper Elements

**Important** To prevent engine damage, always operate the engine with the paper air cleaner installed.

1. Carefully slide the element into the compartment (Fig. 35).
2. Place the air cleaner cover into the compartment and latch the retaining clips (Fig. 35).

## Servicing the Engine Oil

Change the oil:

- After the first 8 operating hours.
- After every 100 operating hours.

**Note:** Change the oil more frequently when operating conditions are extremely dusty or sandy.

Oil Type: Detergent oil (API service SG or SH)

Crankcase Capacity:

- 67 oz. (2.0 l) when the oil filter is removed
- 61 oz. (1.8 l) when the oil filter is **not** removed

Viscosity: See the table below.

### USE THESE SAE VISCOSITY OILS

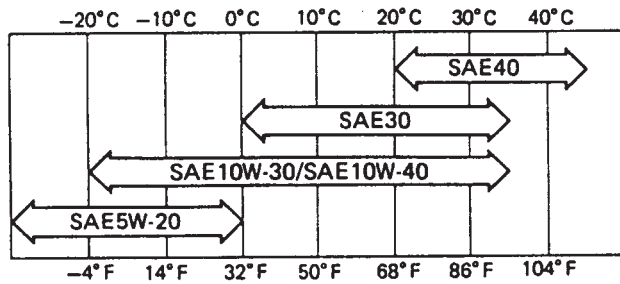

m-4292

## Checking the Oil Level

**Note:** Check the oil when the engine is cold.

1. Disengage the power take off (PTO) and stop the engine. Move the levers to the neutral locked position and apply the parking brake. Remove the key.
2. Clean around the oil dipstick so that dirt cannot fall into the filler hole and damage the engine (Fig. 37).
3. Pull the oil dipstick out and wipe the metal end clean (Fig. 37).
4. Slide the oil dipstick fully into the filler cap. Pull the dipstick out and look at the metal end (Fig. 37). If the oil level is low, slowly pour only enough oil into the filler tube to raise the level to the full mark.

**Important** Do not overfill the crankcase with oil because the engine may be damaged. Do not run the engine with oil below the low mark because the engine may be damaged.

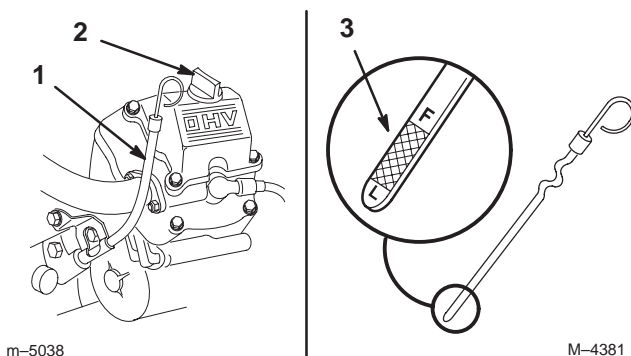

Figure 37

1. Oil dipstick
2. Filler cap
3. Metal end

## Changing the Oil

Replace the oil every 100 hours.

1. Start the engine and let it run for five minutes. This warms the oil so that it drains better.
2. Park the machine so that the drain side is slightly lower than the opposite side to ensure that the oil drains completely. Disengage the power take off (PTO), set the parking brake, stop the engine, and remove the key.
3. Place a pan below the oil drain. Rotate the oil drain valve to allow oil to drain (Fig. 38).
4. When the oil has drained completely, close the drain valve.

**Note:** Dispose of the used oil at a certified recycling center.

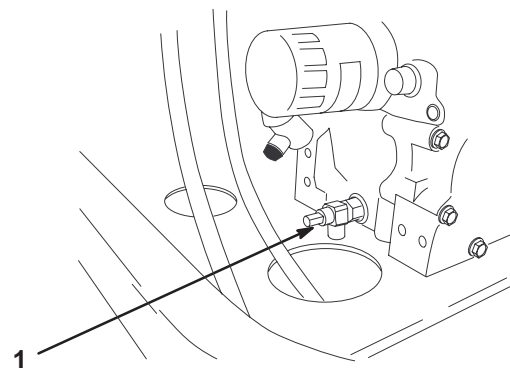

Figure 38

1. Oil drain

5. Slowly pour approximately 80% of the specified oil into the filler cap (Fig. 37). Refer to Servicing the Engine Oil, page 30.
6. Check the oil level; refer to Checking the Oil Level, page 31.
7. Slowly add additional oil to bring it to the full mark.

## Changing the Oil Filter

Replace the oil filter every 200 hours or every other oil change.

**Note:** Change the oil filter more frequently when operating conditions are extremely dusty or sandy.

1. Drain the oil from the engine; refer to Changing the Oil, page 31.
2. Remove the old filter and wipe the filter adapter (Fig. 39) gasket surface.
3. Pour new oil of the proper type in through the center hole. Stop pouring when the oil reaches the bottom of the threads. Allow a minute or two for the oil to be absorbed by the filter material.

- Apply a thin coat of new oil to the rubber gasket on the replacement filter (Fig. 39).

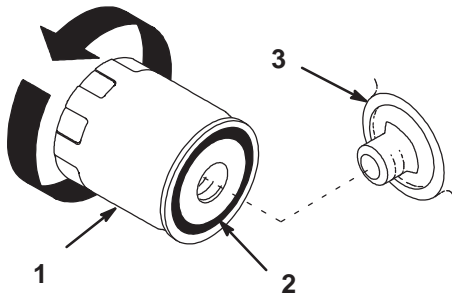

m-1256

**Figure 39**

- Oil filter
- Gasket
- Adapter

- Install the replacement oil filter to the filter adapter. Turn the oil filter clockwise until the rubber gasket contacts the filter adapter; then tighten the filter an additional 1/2 turn (Fig. 39).
- Fill the crankcase with the proper type of new oil; refer to Servicing the Engine Oil, page 30.

## Servicing the Cooling System

### Checking the Radiator Coolant

#### **Danger**

Discharge of hot pressurized coolant or touching hot radiator and surrounding parts can cause severe burns.

- Do not remove the radiator cap when the engine is hot. Always allow the engine to cool at least 15 minutes or until the radiator cap is cool enough to touch without burning your hand before removing the radiator cap.
- Do not touch radiator and surrounding parts that are hot.

Check the cooling system level daily.

Fluid Type: 50/50 mix of permanent antifreeze (ethylene glycol) and water.

Cooling System Capacity: 128 oz. (3.8 l)

#### **Danger**

Rotating shaft and fan can cause personal injury.

- Do not operate the machine without the covers in place.
- Keep fingers, hands and clothing clear of rotating fan and drive shaft.
- Shut off the engine and remove the ignition key before performing maintenance.

#### **Caution**

Swallowing engine coolant can cause poisoning.

- Do not swallow engine coolant.
- Keep out of reach from children and pets.

- Position the machine on a level surface, stop the engine, and set the parking brake.
- Tilt the seat up and tilt the engine hood forward.
- With the engine cool, remove the radiator cap (Fig. 40).
- If the coolant level is low, add a 50/50 mixture of permanent antifreeze and water until the radiator is completely full without overflowing.
- Install the radiator cap. Completely seat the cap by pushing down and turning it until it stops.
- Add a 50/50 coolant mix to the overflow bottle and fill it to the indicator line on the bottle, if required (Fig. 40).

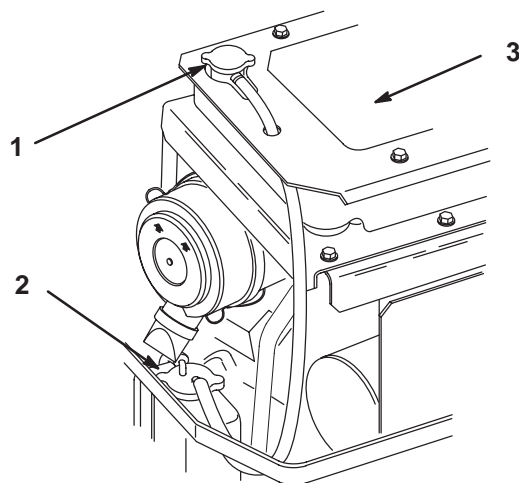

m-5031

**Figure 40**

- Radiator cap
- Antifreeze overflow bottle
- Radiator core and screen



## Cleaning the Cooling System

Clean the cooling system daily before each use.

1. Position the machine on a level surface, stop the engine, and set the parking brake.

**Important** Before starting the engine, clean grass from the pump drive belt compartment. Check more often in dry conditions.

2. Tilt the seat up and raise the rubber flap above the drive belt compartment.
3. Remove debris from the drive belt compartment and hydraulic pumps.
4. Remove debris from the screen on the engine cover.
5. Tilt the engine cover forward.
6. Remove debris from the radiator core and engine (Fig. 40).

**Important** Do not damage the radiator cooling fins.

7. Inspect the seals on the engine cover and replace them if needed.
8. Close the engine cover and tilt the seat back.

## Changing the Engine Coolant

Change the engine coolant every 400 hours.



### Danger



Discharge of hot pressurized coolant or touching hot radiator and surrounding parts can cause severe burns.

- Do not remove the radiator cap when the engine is hot. Always allow the engine to cool at least 15 minutes or until the radiator cap is cool enough to touch without burning your hand before removing the radiator cap.
- Do not touch radiator and surrounding parts that are hot.



### Danger



Rotating shaft and fan can cause personal injury.

- Do not operate the machine without the covers in place.
- Keep fingers, hands and clothing clear of rotating fan and drive shaft.
- Shut off the engine and remove the ignition key before performing maintenance.

1. Position the machine on a level surface, stop the engine, and set the parking brake.
2. Tilt the seat up and tilt the engine hood forward.
3. With the engine cool, drain the coolant by loosening the drain cock in the right rear corner (Fig. 41).
4. The engine block must be drained by removing the drain plug from the engine block (Fig. 42).

**Note:** The drain plug is black in color and is located near the oil filter (Fig. 42).

5. Install all drain plugs, the radiator hose, and tighten the drain cock.

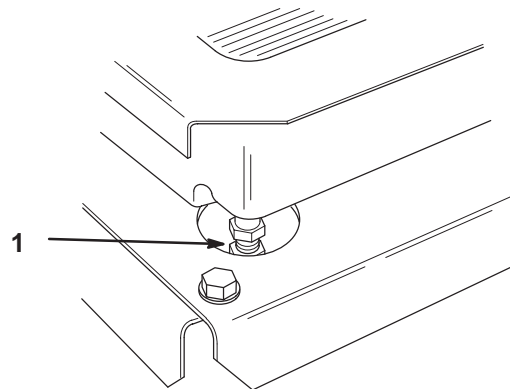

M-4379

Figure 41

1. Drain cock (right rear of radiator)

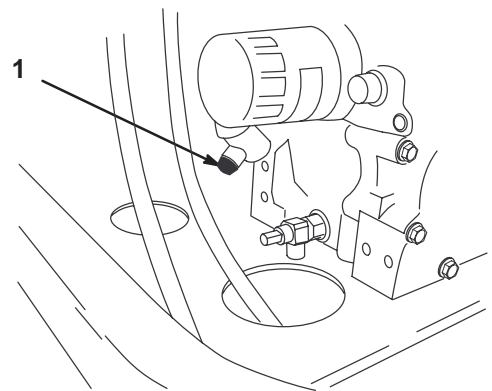

m-5030

Figure 42

1. Coolant drain plug (black in color)
6. Drain the coolant from the overflow bottle.
7. Remove the radiator cap and add a 50/50 mixture of permanent antifreeze and water until the radiator is completely full.
8. Wait 2 minutes and check if the coolant stays up to the full level. Add a 50/50 mixture of permanent antifreeze and water until the radiator is completely full, if required. Repeat until the coolant stays up to the full level.

9. With the radiator cap off, tilt the engine cover down and put the seat down. Start the engine. Run the engine until it is warm.
10. Tilt the seat up, tilt the engine hood forward, and keep the engine running. As air is purged from the engine block and the coolant level drops, add additional coolant to the radiator until it is full.
11. Install the radiator cap. Completely seat the cap by pushing down and turning it until it stops.
12. Shut off the engine.
13. Check for any leaks in the cooling system.
14. Close the engine cover and tilt the seat back.

**Important** Check the coolant level after the first 8 hours of changing the coolant.

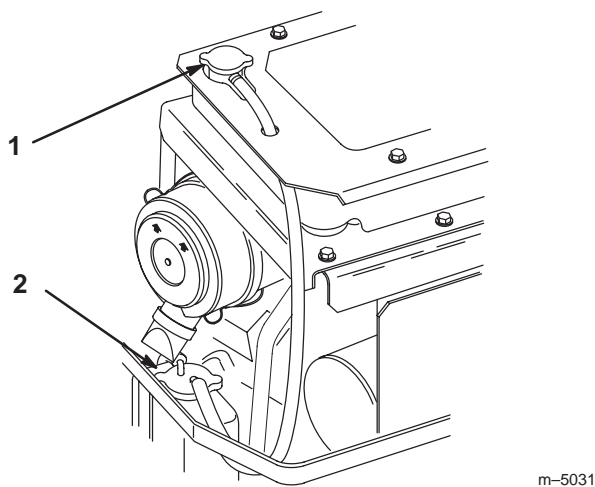

**Figure 43**

1. Radiator cap
2. Antifreeze overflow bottle

## Inspecting the Cooling System

Inspect the radiator and the hoses initially and after the first 8 operating hours.

Inspect the radiator and the hoses every 200 hours.

Check the hoses and radiator for cracks, dents, and fractured seams. Repair or replace damaged hoses or the radiator.

## Servicing the Spark Plug

Check the spark plug(s) after every 100 operating hours. Make sure that the air gap between the center and side electrodes is correct before installing the spark plug. Use a spark plug wrench for removing and installing the spark plug(s) and a gapping tool/feeler gauge to check and adjust the air gap. Install a new spark plug(s) if necessary.

Type: NGK BPR2ES (or equivalent)

Air Gap: 0.030 inch (0.76 mm)

### Removing the Spark Plug(s)

1. Disengage the power take off (PTO) and stop the engine. Move the levers to the neutral locked position and apply the parking brake. Remove the key.
2. Clean around the spark plug(s) to prevent dirt from falling into the engine and potentially causing damage. Pull the wire(s) off of the spark plug(s) (Fig. 44).
3. Remove the spark plug(s) and metal washer.

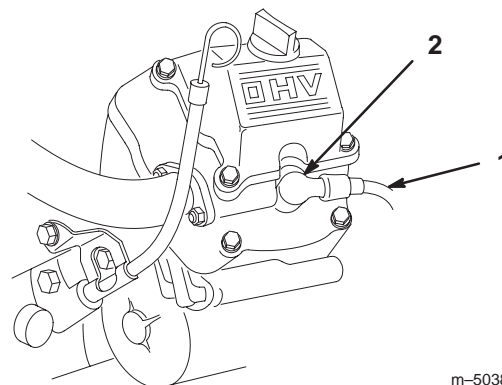

**Figure 44**

1. Spark plug wire
2. Spark plug

### Checking the Spark Plug

1. Clean the electrodes by scraping or with a wire brush to remove carbon deposits and wetness (Fig. 45).
2. Inspect the spark plug (Fig. 45).

**Important** Always replace the spark plug(s) when it has a black coating, worn electrodes, an oily film, or cracks.

3. Check the gap between the center and side electrodes (Fig. 45). Bend the side electrode (Fig. 45) if the gap is not correct.

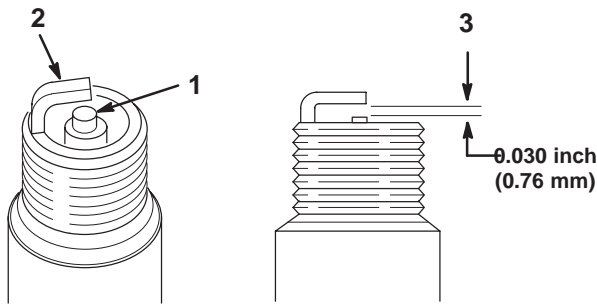

**Figure 45**

m-3215

1. Center electrode insulator
2. Side electrode
3. Air gap (not to scale)

## Installing the Spark Plug(s)

1. Install the spark plug(s). Make sure that the air gap is set correctly.
2. Tighten the spark plug(s) to 17 ft.-lb. (23 N·m).
3. Push the wire(s) onto the spark plug(s) (Fig. 44).

## Replacing the Fuel Filter

Replace the fuel filter after every 300 operating hours or yearly, whichever occurs first.

### Replacing the Fuel Filter

Never install a dirty filter if it is removed from the fuel line.

1. Disengage the power take off (PTO) and stop the engine. Move the levers to the neutral locked position and apply the parking brake. Remove the key.
2. Close the fuel shut-off valve on the console.
3. Tilt the seat forward to access the fuel filter.
4. Squeeze the ends of the hose clamps together and slide them away from the filter (Fig. 46).
5. Remove the filter from the fuel lines.
6. Install a new filter and move the hose clamps close to the filter (Fig. 47).
7. Wipe up any spilled fuel.
8. Open the fuel shut-off valve on the console.

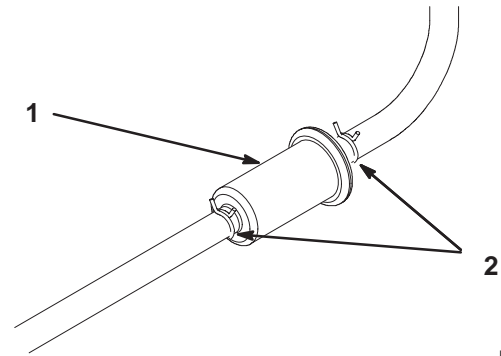

**Figure 46**

M-4384

1. Filter
2. Hose clamp

## Draining the Fuel Tank



**Danger**



**In certain conditions, gasoline is extremely flammable and highly explosive. A fire or explosion from gasoline can burn you and others and can damage property.**

- Drain gasoline from the fuel tank when the engine is cold. Do this outdoors in an open area. Wipe up any gasoline that spills.
- Never smoke when draining gasoline, and stay away from an open flame or where a spark may ignite the gasoline fumes.

1. Park the machine on a level surface, to ensure that the fuel tank drains completely. Then disengage the power take off (PTO), set the parking brake, stop the engine, and remove the key.
  2. Close the fuel shut-off valve (Fig. 47).
  3. Loosen the hose clamp at the fuel filter and slide it up the fuel line away from the fuel filter (Fig. 47).
  4. Pull the fuel line off of the fuel filter (Fig. 47). Open the fuel shut-off valve and allow gasoline to drain into a gas can or drain pan.
- Note:** Now is the best time to install a new fuel filter because the fuel tank is empty.
5. Install the fuel line onto the fuel filter. Slide the hose clamp close to the fuel filter to secure the fuel line (Fig. 47).

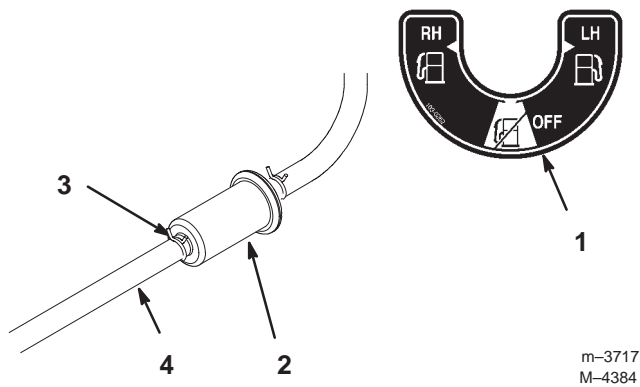

Figure 47

- |                        |               |
|------------------------|---------------|
| 1. Fuel shut-off valve | 3. Hose clamp |
| 2. Fuel filter         | 4. Fuel line  |

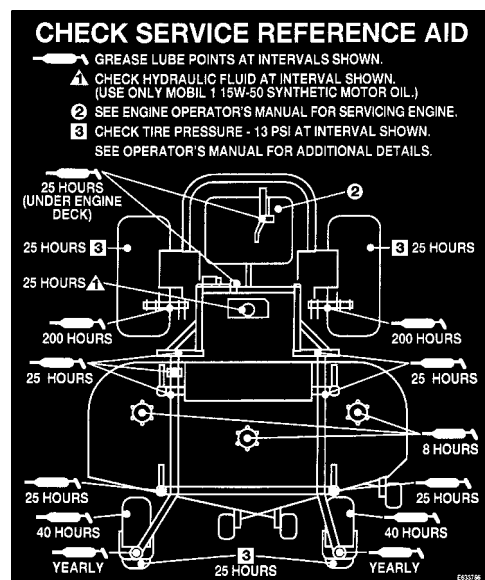

Figure 48

## Servicing the Spark Arrester

Inspect the spark arrester every 50 hours for damage, such as holes in the screen, and for buildup on the screen. If it is damaged, replace it with a new spark arrester. If it is dirty, remove it and clean the screen with a wire brush and/or soak it in solvent.

## Greasing and Lubrication

Lubricate the machine when shown on the **Check Service Reference Aid** decal (Fig. 48). Grease more frequently when operating conditions are extremely dusty or sandy.

Grease Type: General-purpose grease

### How to Grease

1. Disengage the power take off (PTO) and stop the engine. Move the levers to the neutral locked position and apply the parking brake. Remove the key.
2. Clean the grease fittings with a rag. Make sure to scrape any paint off of the front of the fitting(s).
3. Connect a grease gun to the fitting. Pump grease into the fittings until grease begins to ooze out of the bearings.
4. Wipe up any excess grease.

### Where to Add Grease

Lubricate the grease fittings as shown on the **Check Service Reference Aid** decal (Fig. 48).

## Greasing the Front Caster Pivots

Lubricate the front caster pivots once a year.

1. Remove the dust cap and adjust the caster pivots. Keep dust cap off until greasing is done. Refer to Adjusting the Caster Pivot Bearing, page 42.
2. Remove the hex plug. Thread a grease zerk into hole.
3. Pump grease into zerk until it oozes out around top bearing.
4. Remove grease zerk in hole. Reinstall hex plug and cap.

## Greasing the Bearings

The cutting unit must be lubricated daily; refer to the Recommended Maintenance Schedule, page 27. Grease with No. 2 general purpose lithium base or molybdenum base grease.

**Important** Make sure that the cutting unit spindles are full of grease daily.

1. Stop the engine, set the parking brake, remove the key, and disconnect the spark plug wire(s) from the spark plug(s).
2. Grease the fittings on the three spindle bearings until grease comes out of the lower seals (Fig. 49).

- Grease the fittings on the push arms (Fig. 49).

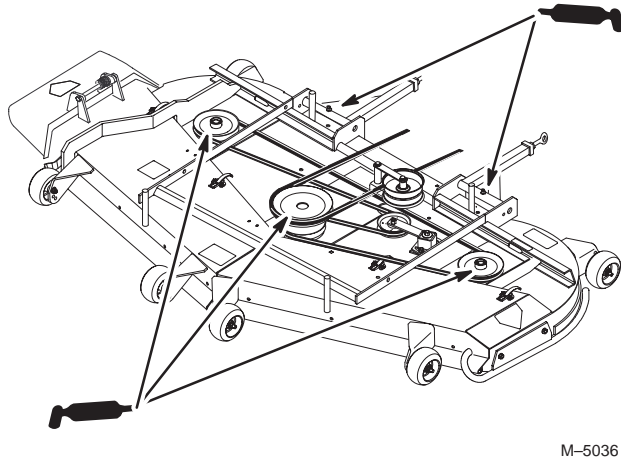

Figure 49

## Where to Add Light Oil or Spray Lubrication

Lubricate the machine in the following areas with spray type lubricant or light oil. Lubricate every 160 hours.

- Seat switch actuator
- Brake handle pivot
- Brake rod bushings
- Motion control bronze bushings

## Checking the Tire Pressure

Maintain the air pressure in the front and rear tires as specified. Uneven tire pressure can cause uneven cut. Check the pressure at the valve stem after every 50 operating hours or monthly, whichever occurs first (Fig. 50). Check the tires when they are cold to get the most accurate pressure reading.

Pressure: 13 psi (90 kPa) drive wheels and caster wheels.

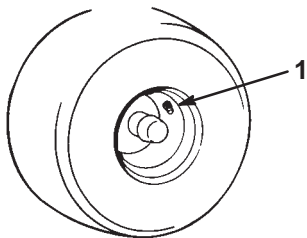

Figure 50

- Valve stem

# Servicing the Hydraulic System

## Checking the Hydraulic Fluid

Check the hydraulic fluid level before engine is first started.

Check the hydraulic fluid level after first 8 operating hours.

Check the hydraulic fluid level after every 25 operating hours.

Fluid Type: Mobil 1 15W-50 synthetic motor oil or equivalent synthetic oil.

**Important** Use the oil specified or equivalent. Other fluids could cause system damage.

Hydraulic System Oil Capacity: 67 oz. (2 l)

**Note:** There are two ways of checking the hydraulic oil. One is when the oil is warm and one is when the oil is cold. The baffle inside the tank has two levels depending if the oil is warm or cold.

1. Position the machine on a level surface and set the parking brake.
2. Clean the area around the filler neck of the hydraulic tank (Fig. 51).
3. Remove the cap from the filler neck. Look inside to check if there is fluid in the reservoir (Fig. 51).
4. If there is no fluid, add fluid to the reservoir until it reaches the *cold* level of the baffle.
5. Run the machine at low idle for 15 minutes to allow any air to purge out of the system and warm the fluid; refer to Starting and Stopping the Engine, page 19.
6. Recheck the fluid level while the fluid is warm. If required, add fluid to the reservoir until it reaches the *hot* level of the baffle.

**Note:** The fluid level should be to the top of the *hot* level of the baffle, when the fluid is warm (Fig. 51).

7. Install the cap on the filler neck.

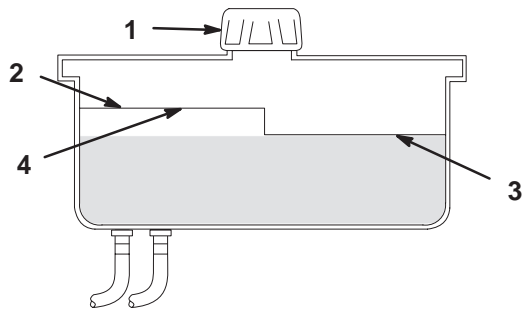

m-5615

**Figure 51**

- |           |                          |
|-----------|--------------------------|
| 1. Cap    | 3. Cold fluid level—full |
| 2. Baffle | 4. Hot fluid level—full  |

**Warning**

**Hydraulic fluid escaping under pressure can penetrate skin and cause injury.**

- **If hydraulic fluid is injected into the skin it must be surgically removed within a few hours by a doctor familiar with this type of injury. Gangrene may result if this is not done.**
- **Keep body and hands away from pin hole leaks or nozzles that eject high pressure hydraulic fluid.**
- **Use cardboard or paper to find hydraulic leaks.**
- **Safely relieve all pressure in the hydraulic system before performing any work on the hydraulic system.**
- **Make sure all hydraulic fluid hoses and lines are in good condition and all hydraulic connections and fittings are tight before applying pressure to hydraulic system.**

## Replacing the Hydraulic Filter

Change the hydraulic filter:

- After the first 8 operating hours.
- After every 200 operating hours.

Use summer filter above 32°F (0°C)

Use winter filter below 32°F (0°C)

1. Disengage the power take off (PTO) and stop the engine. Move the levers to the neutral locked position and apply the parking brake. Remove the key.

**Important** Do not substitute an automotive oil filter or severe hydraulic system damage may result.

2. Tilt the seat forward to access the filter.
3. Remove the hydraulic reservoir cap and temporarily cover the opening with a plastic bag and rubber band to prevent all hydro fluid from draining out.
4. Place a drain pan under the filter, remove the old filter, and wipe the filter adapter gasket surface clean (Fig. 52).

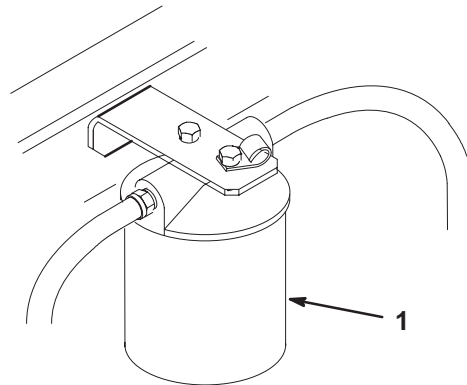

M-4384

**Figure 52**

1. Hydraulic filter

5. Apply a thin coat of hydro fluid to the rubber gasket on the replacement filter (Fig. 53).
6. Install the replacement hydraulic filter onto the filter adapter. Do not tighten.
7. Remove the plastic bag from the tank opening and allow the filter to fill with hydro fluid.
8. When fluid overflows the filter, turn the oil filter clockwise until the rubber gasket contacts the filter adapter; then tighten the filter an additional 1/2 turn (Fig. 53).
9. Clean up any spilled fluid.
10. If there is no fluid, add fluid to the reservoir to approximately 1/4 inch (6 mm) below the top of the baffle.
11. Start the engine and let it run for about two minutes to purge air from the system. Stop the engine and check for leaks. If one or both wheels will not drive, refer to Bleeding the Hydraulic System, page 39.
12. Check the fluid level in the hydraulic tank while the fluid is warm. Add fluid to raise the level to top of the baffle, if required. **Do not overfill.**

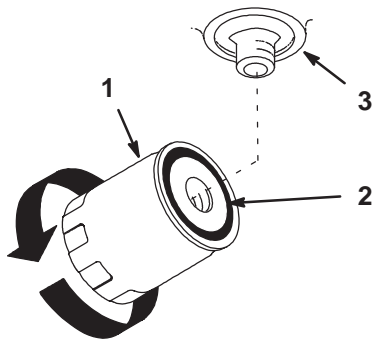

m-1256

**Figure 53**

- |                     |            |
|---------------------|------------|
| 1. Hydraulic filter | 3. Adapter |
| 2. Gasket           |            |

## Bleeding the Hydraulic System

The traction system is self bleeding; however, it may be necessary to bleed the system if the fluid is changed or after work is performed on the system.

1. Raise the rear of the machine so that the wheels are off of the ground and support it with jack stands.
2. Start the engine and run it at idle speed. Engage the traction on one side and spin the wheel by hand.
3. When the wheel begins to spin on its own, keep it engaged until the wheel drives smoothly (minimum 2 minutes).
4. Check the hydraulic fluid level as it drops and add as required to maintain the proper level.
5. Repeat this procedure on the opposite wheel.

## Checking the Hydraulic Lines

After every 100 operating hours, check the hydraulic lines and hoses for leaks, loose fittings, kinked lines, loose mounting supports, wear, weather and chemical deterioration. Make necessary repairs before operating.

**Note:** Keep the areas around the hydraulic system clean from grass and debris build up.



## Warning



Hydraulic fluid escaping under pressure can penetrate skin and cause injury.

- If hydraulic fluid is injected into the skin it must be surgically removed within a few hours by a doctor familiar with this type of injury. Gangrene may result if this is not done.
- Keep body and hands away from pin hole leaks or nozzles that eject high pressure hydraulic fluid.
- Use cardboard or paper to find hydraulic leaks.
- Safely relieve all pressure in the hydraulic system before performing any work on the hydraulic system.
- Make sure all hydraulic fluid hoses and lines are in good condition and all hydraulic connections and fittings are tight before applying pressure to hydraulic system.

## Adjusting the Handle Neutral

If motion control levers do not align, or move easily into the console notch, adjustment is required. Adjust each lever, spring and rod separately.

**Note:** Motion control levers must be installed correctly. See Installing the Motion Control Levers, page 15.

1. Stop the engine, remove ignition key and tilt seat forward.
2. Begin with either the left or right motion control lever.
3. Move lever to the neutral position but **not locked** (Fig. 55).
4. Pull lever back until the clevis pin (on arm below pivot shaft) contacts the end of the slot (just beginning to put pressure on the spring) (Fig. 55).
5. Check where the control lever is relative to notch in console (Fig. 54). It should be centered allowing lever to pivot outward to the neutral lock position.

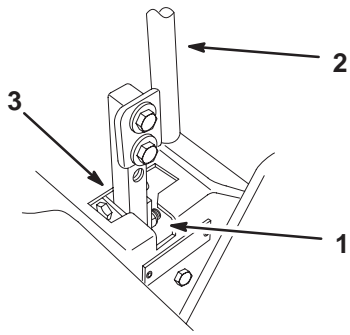

m-6282

**Figure 54**

- |                            |                     |
|----------------------------|---------------------|
| 1. Neutral locked position | 3. Neutral position |
| 2. Control lever           |                     |

- If adjustment is needed, loosen the nut and jam nut against the yoke (Fig. 55).
- Apply slight rearward pressure on the motion control lever, turn the head of the adjustment bolt in the appropriate direction until the control lever is centered in neutral lock position (Fig. 54).

**Note:** Keeping rearward pressure on the lever will keep the pin at the end of the slot and allow the adjustment bolt to move the lever to the appropriate position.

- Tighten the nut and jam nut (Fig. 55).
- Repeat on the opposite side of unit.

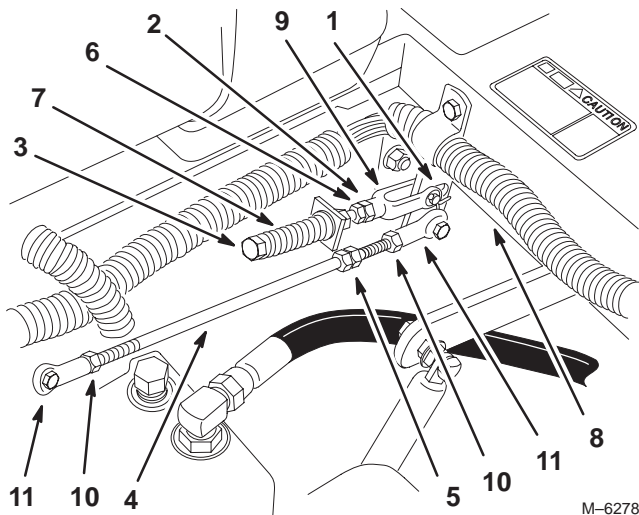

M-6278

**Figure 55**

- |                       |                |
|-----------------------|----------------|
| 1. Clevis pin in slot | 7. Spring      |
| 2. Nut against yoke   | 8. Pivot shaft |
| 3. Adjustment bolt    | 9. Yoke        |
| 4. Pump rod           | 10. Locknut    |
| 5. Double nuts        | 11. Ball joint |
| 6. Jam Nut            |                |

## Setting the Hydraulic Pump Neutral

**Note:** Adjust handle neutral first. That has to be correct before the following adjustment can be made.



### Danger



**Mechanical or hydraulic jacks may fail to support machine and cause a serious injury.**

- Use jack stand when supporting machine.
- Do not use hydraulic jacks.



### Warning



**Engine must be running so motion control adjustment can be performed. Contact with moving parts or hot surfaces may cause personal injury.**

**Keep hands, feet, face, clothing and other body parts away from rotating parts, muffler and other hot surfaces.**

This adjustment must be made with drive wheels turning.

- Raise the frame and block up the machine so drive wheels can rotate freely.
- Disconnect electrical connector from the seat safety switch. **Temporarily** install a jumper wire across terminals in the wiring harness connector.
- Slide seat forward, disconnect prop rod and tilt seat fully forward.

## Setting the Right-hand Hydraulic Pump Neutral

- Start the engine, open throttle 1/2 way and release parking brake. Refer to Starting and Stopping the Engine, page 19.

**Note:** Motion control lever must be in neutral while making any adjustments.

- Adjust pump rod length by rotating the knob, in the appropriate direction, until the wheel is still or slightly creeping in reverse (Fig. 56).
- Move motion control lever forward and reverse, then back to neutral. Wheel must stop turning or slightly creep in reverse.
- Open throttle to fast. Make sure wheel remains stopped or slightly creeps in reverse, adjust if necessary.



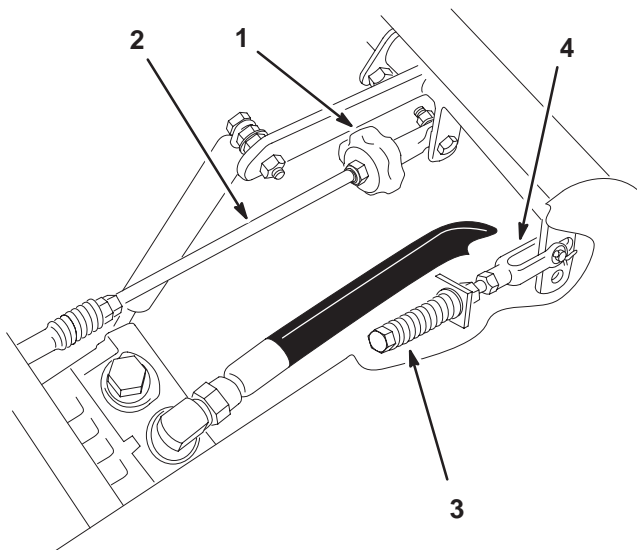

m-6281

**Figure 56**

- |                  |                    |
|------------------|--------------------|
| 1. Tracking knob | 3. Adjustment bolt |
| 2. Pump rod      | 4. Yoke            |

## Setting the Left-hand Hydraulic Pump Neutral

1. Loosen the locknuts at the ball joints on pump control rod (Fig. 55).
2. Start the engine, open throttle 1/2 way and release parking brake. Refer to Starting and Stopping the Engine, page 19.

**Note:** Motion control lever must be in neutral while making any adjustments.

**Note:** The front nut on the pump rod has left-hand threads.

3. Adjust pump rod length by rotating double nuts on rod, in the appropriate direction, until wheel is still or slightly creeps in reverse (Fig. 55).
4. Move motion control lever forward and reverse, then back to neutral. Wheel must stop turning or slightly creep in reverse.
5. Open throttle to fast. Make sure wheel remains stopped or slightly creeps in reverse, re-adjust if necessary.
6. Tighten the locknuts at the ball joints (Fig. 55).



## Warning



Electrical system will not perform proper safety shut off with jumper wire installed.

- Remove jumper wire from wire harness connector and plug connector into seat switch when adjustment is completed.
- Never operate this unit with jumper installed and seat switch bypassed.

7. After both pump neutrals are set, shut off the machine.
8. Remove jumper wire from wire harness connector and plug connector into seat switch.
9. Reinstall prop rod and lower the seat into position.

## Adjusting the Tracking

The right hand pump has a knob for adjusting the tracking.

**Important** Adjust the handle neutral and hydraulic pump neutral before adjusting the tracking. Refer to Adjusting the Handle Neutral on page 39 and Adjusting the Hydraulic Pump Neutral on page 40.

1. Push both control levers forward the same distance.
  2. Check if the machine pulls to one side. If it does, stop the machine and set the parking brake.
  3. Tip the seat up to access the tracking knob.
- Note:** Determine the left and right sides of the machine from the normal operating position.
4. To make the machine go right, turn the knob towards the rightside of the machine. Refer to figure 57.
  5. To make the machine go left, turn the knob towards the leftside of the machine. Refer to figure 57.
  6. Repeat adjustment until the tracking is correct.

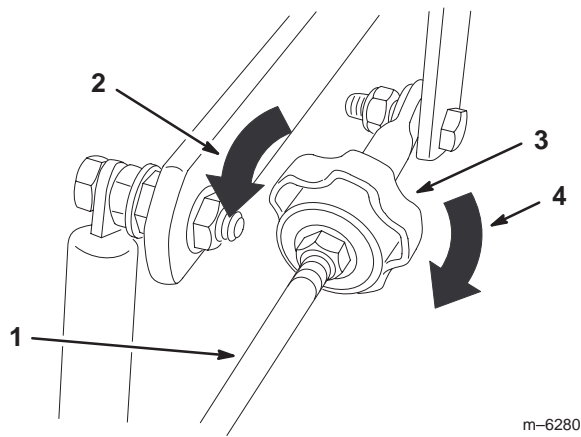

**Figure 57**

m-6280

1. Pump rod
2. Turn this way to track left
3. Tracking knob
4. Turn this way to track right

## Adjusting the Caster Pivot Bearing

Check after every 500 operating hours or at storage, whichever comes first.

1. Stop the engine, set the parking brake, remove the key, and disconnect the spark plug wire(s) from the spark plug(s).
2. Remove the dust cap from the caster and tighten the locknut (Fig. 58).
3. Tighten until the spring washers are flat and then back off 1/4 turn to properly set the preload on the bearings (Fig. 58).

**Important** Make sure that the spring washers are installed correctly as shown in Figure 58.

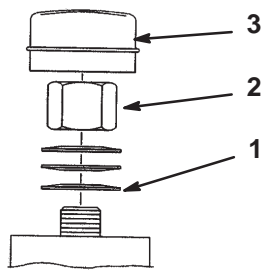

**Figure 58**

M-4640

1. Spring washers
2. Locknut
3. Dust cap

## Checking the Wheel Hub Slotted Nut

Check after every 500 operating hours.

The slotted nut needs to be torqued to 125 ft.-lb. (170 N·m).

1. Stop the engine, set the parking brake, remove the key, and disconnect the spark plug wire(s) from the spark plug(s).
2. Remove the cotter pin.
3. Torque the slotted nut to 125 ft.-lb. (170 N·m) (Fig. 59).
4. Check the distance from the bottom of the slot in the nut to the inside edge of the hole. Two threads or less should be showing (Fig. 59).
5. If more than two threads are showing, remove the nut and install a washer between the hub and nut (Fig. 59).
6. Torque the slotted nut to 125 ft.-lb. (170 N·m) (Fig. 59).
7. Tighten the nut until the next set of slots line up with the hole in the shaft (Fig. 59).
8. Install the cotter pin.

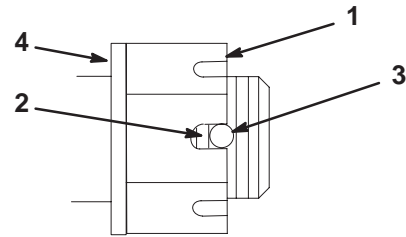

**Figure 59**

m-4638

1. Slotted nut
2. Two threads or less showing
3. Hole in threaded rod
4. Washer (if needed)

## Adjusting the Mower Level

1. Position the mower on a flat surface. Stop the engine, set the parking brake, remove the key, and disconnect the spark plug wire(s) from the spark plug(s).
2. Check the tire pressure of all 4 tires. If needed, adjust to 13 psi (90 kPa).
3. Set the anti-scalp rollers to the top holes or remove them completely for this adjustment.
4. Raise the deck to the transport position and take all of the force off of the two large deck lift springs by loosening the nut in front of each spring (Fig. 60).

- Place 2 thick blocks (1-1/2 inch [38 mm]) under the rear left and right lower edge of the mower. Place 1 block (2-1/4 inch [57 mm]) under the front center lower edge of the mower. Lower the mower to the 2 inch (51 mm) height-of-cut position (Fig. 60).

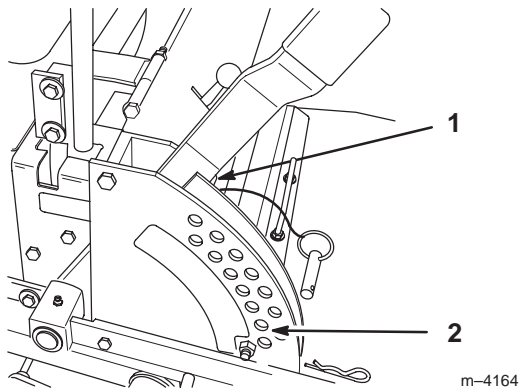

**Figure 60**

- Transport position
- 2 inch (51 mm) height-of-cut

- Loosen the 4 top chain bolts in the slots. Check the length of the rod/swivel assemblies. The distance from the outside of the rear swivel to the outside of the front swivel should be 19-17/32 inch (496 mm) (Fig. 61). Make sure that all four swivels move freely in the holes.

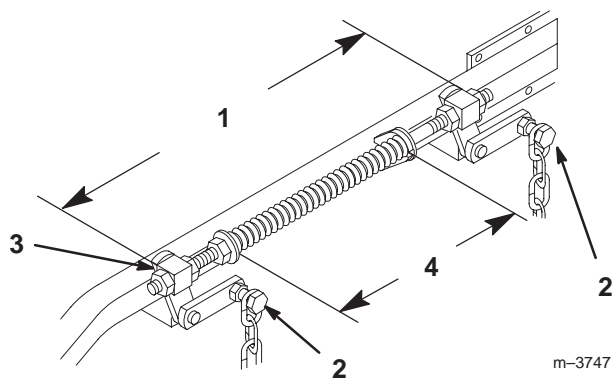

**Figure 61**

- |  |  |
|--|--|
| 1. 19-17/32 inch (496 mm)<br>outside swivels | 3. Front swivel                              |
| 2. Top chain bolt                            | 4. 10-1/4 inch (260 mm)<br>spring compressed |

- If the measurement is not 19-17/32 inch (496 mm) on each side, adjust by turning the nuts on either side of the front swivels.
- Lift up on the 4 top chain attachment bolts, in the slots, to take the slack out of the chains and tighten the flange locknuts. (The deck is still supported by two rear and one front blocks under the mower.)
- If the bolts contact the end of the slots, shorten or lengthen the rod/swivel assemblies as required, for extra clearance. Adjust each side the same amount.

**Note:** When properly adjusted, the front blade tip will be slightly lower than the rear blade tip. See Checking for Bent Blades on page 28 to measure.

- Recheck that the blocks just fit just under the mower and that the tension on all four chains is approximately equal. Tighten the chain attachment bolts securely.
- Measure the height of cut. This can be checked with the same procedure as Checking for Bent Blades on page 28.
- Install the anti-scalp rollers for proper height-of-cut and tighten them securely.
- Raise the deck lift lever to the transport position (Fig. 60).
- Adjust the compression springs by turning the front spring nuts so that the distance between the two large washers is 11 inch (279 mm) (Fig. 61). Clockwise will shorten the spring; counterclockwise will lengthen the spring.
- Adjust the compression springs by turning the front spring nuts so that the distance between the two large washers is 11 inch (279 mm) (Fig. 61). Clockwise will shorten the spring; counterclockwise will lengthen the spring.

**Note:** Make sure that all hardware is tight.

## Cleaning Under the Deck

Remove grass buildup under the deck daily.

- Position the mower on a flat surface. Stop the engine, set the parking brake, remove the key, and disconnect the spark plug wire(s) from the spark plug(s).
- Raise the deck to the transport position.
- Raise the front of the machine by using the Z Stand; refer to Using the Z Stand, page 24.



### Warning



**Unit could fall onto someone and cause serious injury or death.**

- Use extreme caution when operating unit on Z Stand.
- Use only for cleaning deck and removing blades.
- Do not keep unit on Z Stand for extended periods of time.
- Always shut engine off and set parking brake before performing any maintenance to deck.

## Belt Inspection

Inspect all belts every 100 hours.

Check belts for cracks, frayed edges, burn marks, or any other damage. Replace damaged belts.

## Replacing the Deck Belt

Squealing when the belt is rotating, blades slipping when cutting grass, frayed belt edges, burn marks, and cracks are signs of a worn deck belt. Replace the deck belt if any of these conditions are evident.

1. Stop the engine, set the parking brake, remove the key, and disconnect the spark plug wire(s) from the spark plug(s).
2. Remove the PTO drive belt; refer to Replacing the PTO Drive Belt, page 44.
3. Loosen the two nuts securing the idler plate and move the idler arm to relieve the belt tension on the idler pulley; then remove the worn deck belt (Fig. 62).
4. Install the new deck belt around the spindle pulleys, belt guide, the idler pulley, and in the lower groove of the center spindle pulley (Fig. 62).

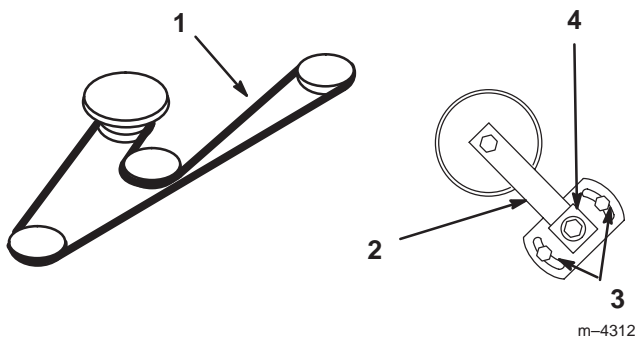

**Figure 62**

Top View

- |              |                        |
|--------------|------------------------|
| 1. Deck Belt | 3. Idler nuts          |
| 2. Idler Arm | 4. Idler adjusting nut |

5. Using a socket and torque wrench, rotate the idler adjusting nut until the torque is 25–30 ft.-lb. (34–41 N·m). Tighten the two nuts.
6. Install the PTO drive belt; refer to Replacing the PTO Drive Belt, page 44.

## Replacing the PTO Drive Belt

Squealing when the belt is rotating, blades slipping when cutting grass, frayed belt edges, burn marks, and cracks are signs of a worn drive belt. Replace the PTO drive belt if any of these conditions are evident.

1. Stop the engine, set the parking brake, remove the key, and disconnect the spark plug wire(s) from the spark plug(s).
2. Remove the clutch retaining strap from the machine frame and unplug the clutch terminal from the wire harness (Fig. 63).
3. Remove the PTO drive belt from the clutch, around the rear idler pulleys, and off of the mower top center pulley (Fig. 64).
4. Remove the bolt, nut, washer, and spacer from the idler pulley bracket assembly. Remove the belt from the bracket assembly (Fig. 64).
5. Install the new PTO drive belt over the clutch, around the rear idler pulleys, and onto the mower top center pulley.

**Note:** Check that belt has only 1/4 twist between each pulley and idler.

6. Install the belt into the idler pulley bracket assembly. Install the bolt, nut, washer, and spacer into the assembly (Fig. 64).

**Note:** The idler belt has to be installed between the spacer and PTO belt idler pulley.

7. Install the clutch retaining strap and plug the clutch terminal into the main wire harness (Fig. 63).

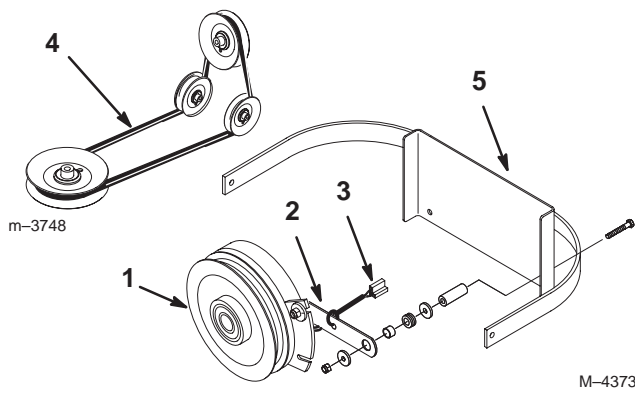

**Figure 63**

- |                           |                  |
|---------------------------|------------------|
| 1. Clutch                 | 4. PTO belt      |
| 2. Clutch retaining strap | 5. Machine frame |
| 3. Clutch terminal        |                  |

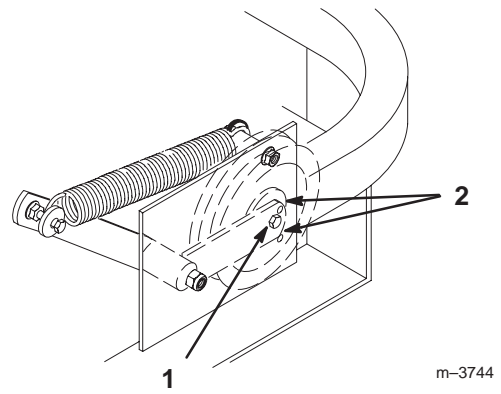

**Figure 65**

- |                                     |                   |
|-------------------------------------|-------------------|
| 1. Center bolt, spring loaded idler | 2. Alignment hole |
|-------------------------------------|-------------------|

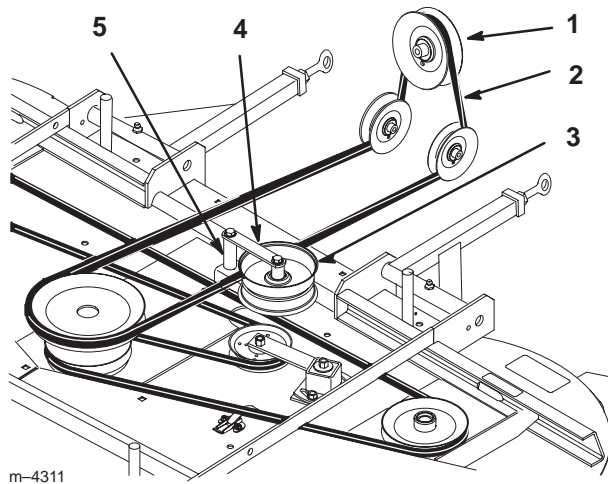
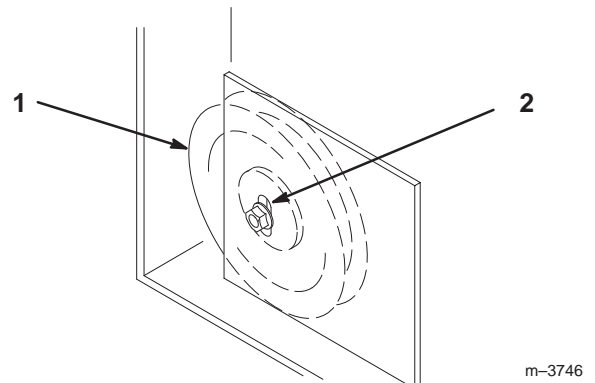

**Figure 64**

- |                            |   |
|----------------------------|---|
| 1. Clutch pulley           | 4. Idler bracket assembly                 |
| 2. PTO drive belt          | 5. Spacer, bolt, nut, and washer (remove) |
| 3. Drive belt idler pulley |   |

8. Check the belt tension. The center bolt of the spring loaded idler must be between the two alignment holes in the left support plate (Fig. 65).

9. If an adjustment is required, loosen the fixed idler on the right support plate and move it up or down in the adjustment slot (Fig. 66). To relieve the belt tension, lift up on the spring loaded idler.



**Figure 66**

- |                |                    |
|----------------|--------------------|
| 1. Fixed Idler | 2. Adjustment slot |
|----------------|--------------------|

10. Check the belt tension again. The center bolt of the spring loaded idler must be between the two alignment holes in the left support plate (Fig. 65). Adjust it, if necessary, and tighten all hardware securely.

11. If the fixed idler contacts the end of the adjustment slot and more belt tension is required, a small change to lengthen the push arms can be made (Fig. 67).

12. To adjust the push arms, loosen the jam nut and rotate the ball joint counterclockwise, one turn at a time. Adjust each side the same amount (Fig. 67).

**Note:** Increase the belt tension by lengthening the push arms and decrease the belt tension by shortening the push arms.

**Important** If the push arm lengths are changed, then the mower deck must be leveled; refer to Adjusting the Mower Level, page 42.

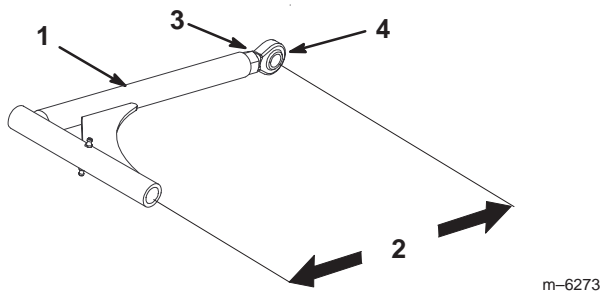

**Figure 67**

- |                             |               |
|-----------------------------|---------------|
| 1. Push arm                 | 3. Jam nut    |
| 2. 15 inch (389 mm) nominal | 4. Ball joint |

## Replacing the Pump Drive Belt

Check the pump drive belt for wear after every 50 hours of operation.

1. Pull the spring loaded idler down and remove the traction belt from the engine and hydro pump pulleys (Fig. 68). Remove the belt between the pulleys.
2. Install the new belt around the engine and hydro pump pulleys (Fig. 68).
3. Pull the spring loaded idler down and align it below the traction belt. Release the pressure on the spring loaded idler (Fig. 68).

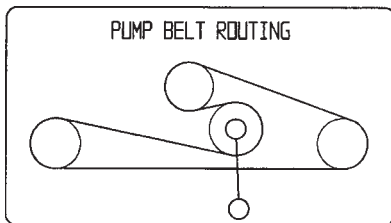

**Figure 68**

## Adjusting the Parking Brake

Check the parking brake for proper adjustment.

1. Disengage the brake lever (lever down).
2. Measure the length of the spring. The measurement should be 2-3/4 inch (70 mm) between the washers (Fig. 69).

3. If an adjustment is necessary, loosen the jam nut below the spring and tighten the nut directly below the yoke (Fig. 69). Turn the nut until the correct measurement is obtained. Tighten the two nuts together and repeat on the opposite side of the unit.
4. Turn the nuts clockwise to shorten the spring length and counterclockwise to lengthen the spring.
5. Engage the parking brake, lever up.
6. Measure the distance between the trunnion roller and the collar on the brake rod. The measurement should be 3/16-1/4 inch (5-7 mm) (Fig. 69).
7. If an adjustment is necessary, loosen the jam nut directly below the yoke. Turn the bottom rod until the correct measurement is obtained (Fig. 69). Tighten the jam nut at the yoke.

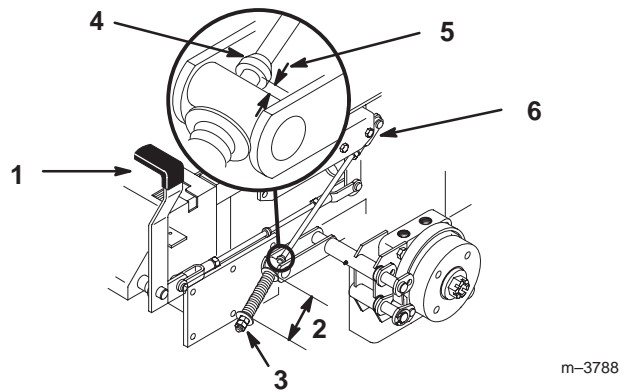

**Figure 69**

- |                               |                           |
|-------------------------------|---------------------------|
| 1. Brake lever                | 4. Collar on brake rod    |
| 2. Spring, 2-3/4 inch (70 mm) | 5. 3/16-1/4 inch (5-7 mm) |
| 3. Adjusting nuts             | 6. Jam nut and yoke       |

## Servicing the Fuses

The electrical system is protected by fuses. It requires no maintenance; however, if a fuse blows, check the component/circuit for a malfunction or short.

Fuse: Main -20 amp, blade-type  
 Alternator -30 amp, blade-type  
 Fan-30 amp, blade-type

1. To gain access to the main fuse, raise the seat. To gain access to the fan and alternator fuses, raise the seat and tilt the engine cover forward.

- To replace a fuse, pull out on the fuse to remove it (Fig. 70).

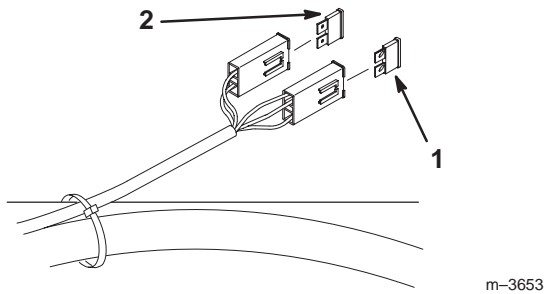

Figure 70

- Fan—30 amp.
- Main—20 amp.

## Servicing the Battery

**Warning**

**Battery posts, terminals, and related accessories contain lead and lead compounds, chemicals known to the State of California to cause cancer and reproductive harm. Wash hands after handling.**

### Checking Electrolyte Level

- With the engine off, open the hood to locate the battery.
- Look at the side of the battery. The electrolyte must be up to the **upper** line (Fig. 71). Do not allow the electrolyte to get below the **lower** line (Fig. 71).
- If the electrolyte is low, add the required amount of distilled water; refer to Adding Water to the Battery, page 48.

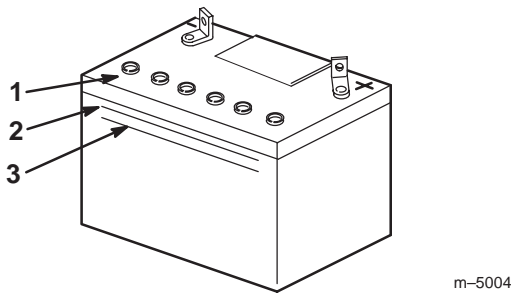

Figure 71

- Filler caps
- Upper** line
- Lower** line

**Danger**

**Battery electrolyte contains sulfuric acid which is a deadly poison and causes severe burns.**

- Do not drink electrolyte and avoid contact with skin, eyes or clothing. Wear safety glasses to shield your eyes and rubber gloves to protect your hands.**
- Fill the battery where clean water is always available for flushing the skin.**
- Follow all instructions and comply with all safety messages on the electrolyte container.**

### Installing the Battery

- Position battery in tray with terminal posts toward the engine (Fig. 72).
- First, install the positive (red) battery cable to positive (+) battery terminal.
- Then install negative battery cable and ground wire to the negative (-) battery terminal.
- Secure cables with 2 bolts (1/4 x 3/4 inch), 2 washers (1/4 inch), and 2 locknuts (1/4 inch) (Fig. 72).
- Slide the red terminal boot onto the positive (red) battery post.
- Secure battery with J-bolts, hold down clamp and 2 washers (1/4 inch), and 2 wing nuts (1/4 inch) (Fig. 72).

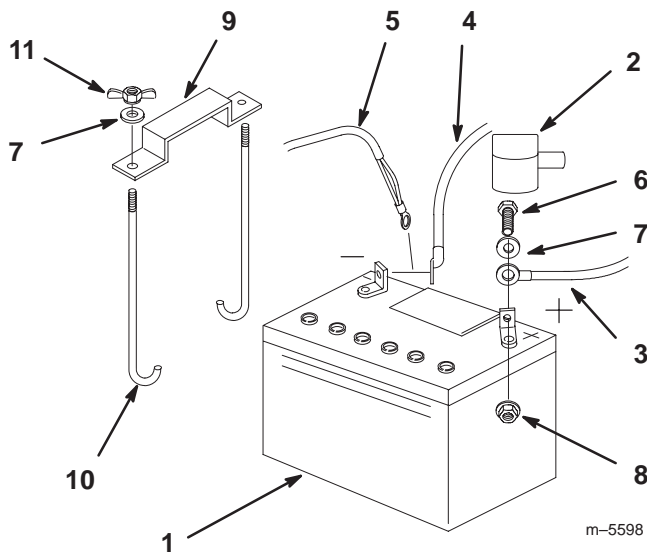

Figure 72

- |                           |                        |
|---------------------------|------------------------|
| 1. Battery                | 7. Washer, 1/4 inch    |
| 2. Terminal boot          | 8. Locknut, 1/4 inch   |
| 3. Positive battery cable | 9. Battery clamp       |
| 4. Negative battery cable | 10. J-bolts            |
| 5. Ground wire            | 11. Wing nut, 1/4 inch |
| 6. Bolt, 1/4 x 3/4 inch   |                        |

## Removing the Battery



### Warning



Battery terminals or metal tools could short against metal machine components causing sparks. Sparks can cause the battery gasses to explode, resulting in personal injury.

- When removing or installing the battery, do not allow the battery terminals to touch any metal parts of the machine.
- Do not allow metal tools to short between the battery terminals and metal parts of the machine.



### Warning



Incorrect battery cable routing could damage the machine and cables causing sparks. Sparks can cause the battery gasses to explode, resulting in personal injury.

- Always *Disconnect* the negative (black) battery cable before disconnecting the positive (red) cable.
- Always *Reconnect* the positive (red) battery cable before reconnecting the negative (black) cable.

1. Disengage the power take off (PTO), set the parking brake, and turn the ignition key to off. Remove the key.
2. Tilt seat up.
3. First disconnect the negative battery cable and ground wire from the negative (-) battery terminal (Fig. 72).
4. Slide the red terminal boot off the positive (red) battery terminal. Then remove positive (red) battery cable (Fig. 72).
5. Remove both wing nuts (1/4 inch) securing the battery clamp (Fig. 72).
6. Remove the battery.

## Adding Water to the Battery

The best time to add distilled water to the battery is just before you operate the machine. This lets the water mix thoroughly with the electrolyte solution.

1. Remove the battery from the machine.
  2. Clean the top of the battery with a paper towel.
- Note:** Never fill the battery with distilled water while the battery installed in the machine. Electrolyte could be spilled on other parts and cause corrosion.
3. Remove the vent caps from the battery (Fig. 71).
  4. Slowly pour distilled water into each battery cell until the level is up to the **upper** line (Fig. 71) on the battery case.

**Important** Do not overfill the battery because electrolyte (sulfuric acid) can cause severe corrosion and damage to the chassis.

5. Wait five to ten minutes after filling the battery cells. Add distilled water, if necessary, until the electrolyte level is up to the **upper** line (Fig. 71) on the battery case.
6. Reinstall battery vent caps.



## Charging the Battery

**Warning**

**Charging the battery produces gasses that can explode.**

**Never smoke near the battery and keep sparks and flames away from battery.**

**Important** Always keep the battery fully charged (1.265 specific gravity). This is especially important to prevent battery damage when the temperature is below 32°F (0°C).

1. Remove the battery from the chassis; refer to Removing the Battery, page 48.
2. Check the electrolyte level; refer to Checking Electrolyte Level, page 47.
3. Make sure the filler caps are installed in battery. Charge battery for 10 to 15 minutes at 25 to 30 amps or 30 minutes at 4–6 amps.
4. When the battery is fully charged, unplug the charger from the electrical outlet, then disconnect the charger leads from the battery posts (Fig. 73).

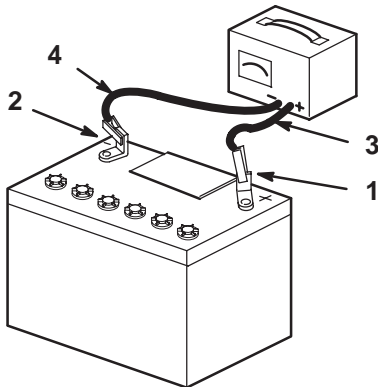

m-4970

**Figure 73**

- |                          |                           |
|--------------------------|---------------------------|
| 1. Positive Battery Post | 3. Red (+) Charger Lead   |
| 2. Negative Battery Post | 4. Black (-) Charger Lead |

5. Install the battery in the machine and connect the battery cables; refer to Installing the Battery on page 47.

**Note:** Do not run the machine with the battery disconnected, electrical damage may occur.

## Waste Disposal

Engine oil, hydraulic oil, and engine coolant are pollutants to the environment. Dispose of these according to your state and local regulations.

## Mercury Tilt Switch

The tilt switch on this unit is located under the seat. Tilt the seat up to gain access.

The tilt switch on this unit contains mercury, a hazardous material. Mercury that is outside a sealed container vaporizes at room temperature. The vapors are harmful. Mercury can be absorbed through the skin. Do not attempt to open or repair this switch.

A very small amount of mercury is contained in a hermetically sealed body. The steel switch is then potted in a hard epoxy in a plastic case. It is unlikely that the mercury will ever escape from the enclosure. These high performance and reliable inexpensive switches are recyclable.

Mercury is an important and beneficial compound but requires special care in handling and disposal. When used and managed properly, mercury is not a threat to people or the environment. This information is presented to users so that they are aware that these switches contain mercury and will apply sound disposal practices when these devices reach their normal end of life or are damaged.

## Mercury Tilt Switch Disposal

Several states have passed laws concerning the disposal of devices containing mercury. In all the remaining states it is advisable to follow similar procedures. The laws state that these sealed devices contain mercury and should not be placed in the garbage until the mercury is removed and reused, recycled, or otherwise managed to ensure that it does not become part of solid waste or waters. Management and disposal practices must be within relevant federal, state, or local laws.

Return the switch to your Toro dealer if it is faulty and is being replaced or if the unit containing the switch is no longer operating and is being scrapped. If the switch is damaged or broken open, use extreme caution in handling. Call your local waste management authority or Toro Customer Service for instructions.

**Caution**

**The mercury contained in the tilt switch is poisonous and exposure to mercury can cause severe illness.**

- **Never attempt to open or repair the tilt switch.**
- **Avoid contact with the mercury.**

# Wiring Diagram

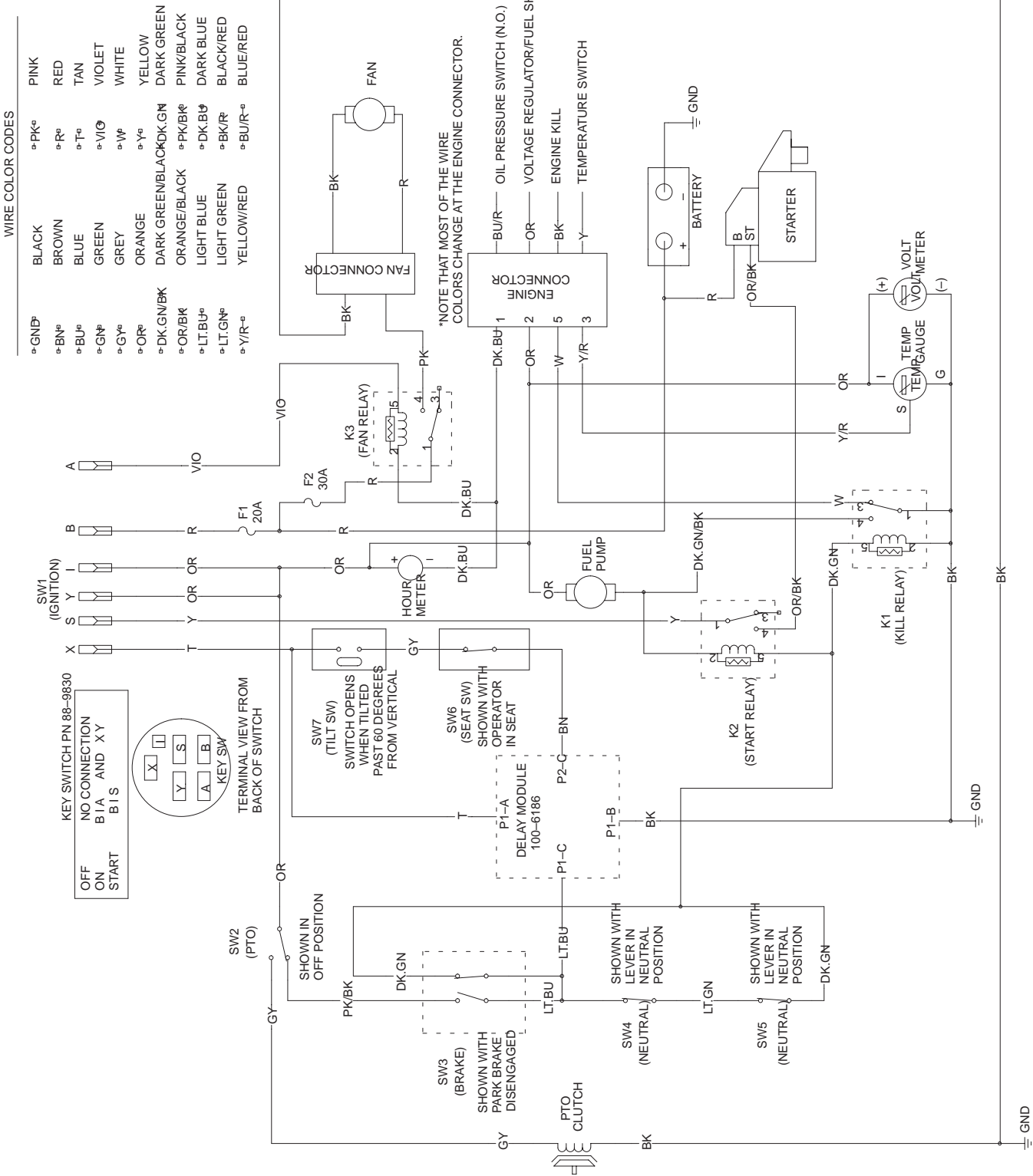

## Cleaning and Storage

1. Disengage the power take off (PTO), set the parking brake, and turn the ignition key to Off. Remove the key.
2. Remove grass clippings, dirt, and grime from the external parts of the entire machine, especially the engine and hydraulic system. Clean dirt and chaff from the outside of the engine cylinder head fins and blower housing.

**Important** You can wash the machine with mild detergent and water. Do not pressure wash the machine. Avoid excessive use of water, especially near the control panel, engine, hydraulic pumps and motors.

3. Service the air cleaner; refer to Servicing the Air Cleaner, page 30.
4. Grease and oil the machine; refer to Greasing and Lubrication, page 36.
5. Change the crankcase oil; refer to Servicing the Engine Oil, page 30.
6. Change the hydraulic filter; refer to Servicing the Hydraulic System, page 37.
7. Check the tire pressure; refer to Checking the Tire Pressure, page 37.
8. Charge the battery; refer to Servicing the Battery, page 47.
9. Scrape any heavy buildup of grass and dirt from the underside of the mower, then wash the mower with a garden hose.
10. Check the condition of the blades; refer to Servicing the Cutting Blades, page 28.
11. Prepare the machine for storage when non-use occurs over 30 days. Prepare machine for storage as follows:
  - A. Add a petroleum based stabilizer/conditioner to fuel in the tank. Follow the mixing instructions from the stabilizer manufacturer. **Do not use an alcohol based stabilizer (ethanol or methanol).**

**Note:** A fuel stabilizer/conditioner is most effective when mixed with fresh gasoline and used at all times.

- B. Run the engine to distribute conditioned fuel through the fuel system (5 minutes).
- C. Stop the engine, allow it to cool, and drain the fuel tank; refer to Draining the Fuel Tank, page 35.
- D. Restart the engine and run it until it stops.
- E. Choke or prime the engine. Start and run the engine until it will not start. Operate the primer, if equipped on the machine, several times to ensure that no fuel remains in the primer system.
- F. Dispose of fuel properly. Recycle as per local codes.

**Important** Do not store stabilizer/conditioned gasoline over 90 days.

12. Remove the spark plug(s) and check its condition; refer to Servicing the Spark Plug, page 34. With the spark plug(s) removed from the engine, pour two tablespoons of engine oil into the spark plug hole. Now use the starter to crank the engine and distribute the oil inside the cylinder. Install the spark plug(s). Do not install the wire on the spark plug(s).
13. Check and tighten all bolts, nuts, and screws. Repair or replace any part that is damaged.
14. Paint all scratched or bare metal surfaces. Paint is available from your Authorized Service Dealer.
15. Store the machine in a clean, dry garage or storage area. Remove the key from the ignition switch and keep it in a memorable place out of reach of children or other unauthorized users. Cover the machine to protect it and keep it clean.

# Troubleshooting

Problem	Possible Causes	Corrective Action
Starter does not crank.	<ol style="list-style-type: none"> <li>1. Blade control (PTO) is engaged.</li> <li>2. Parking brake is not on.</li> <li>3. Operator is not seated.</li> <li>4. Battery is dead.</li> <li>5. Electrical connections are corroded or loose.</li> <li>6. Fuse is blown.</li> <li>7. Relay or switch is defective.</li> </ol>	<ol style="list-style-type: none"> <li>1. Move blade control (PTO) to <b>Disengaged</b>.</li> <li>2. Set parking brake.</li> <li>3. Sit on the seat.</li> <li>4. Charge the battery.</li> <li>5. Check electrical connections for good contact.</li> <li>6. Replace fuse.</li> <li>7. Contact Authorized Service Dealer.</li> </ol>
Engine will not start, starts hard, or fails to keep running.	<ol style="list-style-type: none"> <li>1. Fuel tank is empty.</li> <li>2. Choke is not ON.</li> <li>3. Air cleaner is dirty.</li> <li>4. Spark plug wires is loose or disconnected.</li> <li>5. Spark plugs are pitted, fouled, or gap is incorrect.</li> <li>6. Dirt in fuel filter.</li> <li>7. Dirt, water, or stale fuel is in fuel system.</li> </ol>	<ol style="list-style-type: none"> <li>1. Fill fuel tank with gasoline.</li> <li>2. Move choke lever to ON.</li> <li>3. Clean or replace air cleaner element.</li> <li>4. Install wires on spark plug.</li> <li>5. Install new, correctly gapped spark plugs.</li> <li>6. Replace fuel filter.</li> <li>7. Contact Authorized Service Dealer.</li> </ol>
Engine loses power.	<ol style="list-style-type: none"> <li>1. Engine load is excessive.</li> <li>2. Air cleaner is dirty.</li> <li>3. Oil level in crankcase is low.</li> <li>4. Cooling fins and air passages under engine blower housing are plugged.</li> <li>5. Spark plugs are pitted, fouled, or gap is incorrect.</li> <li>6. Vent in fuel cap is closed.</li> <li>7. Dirt in fuel filter.</li> <li>8. Dirt, water, or stale fuel is in fuel system.</li> </ol>	<ol style="list-style-type: none"> <li>1. Reduce ground speed.</li> <li>2. Clean air cleaner element.</li> <li>3. Add oil to crankcase.</li> <li>4. Remove obstruction from cooling fins and air passages.</li> <li>5. Install new, correctly gapped spark plugs.</li> <li>6. Open vent in fuel cap.</li> <li>7. Replace fuel filter.</li> <li>8. Contact Authorized Service Dealer.</li> </ol>
Engine overheats.	<ol style="list-style-type: none"> <li>1. More coolant is needed.</li> <li>2. (3) air intake screens are dirty.</li> <li>3. Restricted air flow into the engine.</li> <li>4. Radiator fins are dirty.</li> </ol>	<ol style="list-style-type: none"> <li>1. Check and add coolant.</li> <li>2. Clean with every use.</li> <li>3. Inspect and clean the radiator screen with every use.</li> <li>4. Clean the radiator fins.</li> </ol>

<b>Problem</b>	<b>Possible Causes</b>	<b>Corrective Action</b>
	<ul style="list-style-type: none"> <li>5. The crankcase oil level is incorrect.</li> <li>6. The fuel mixture is lean.</li> <li>7. Excessive loading.</li> </ul>	<ul style="list-style-type: none"> <li>5. Fill or drain to the full mark.</li> <li>6. Contact your Authorized Service Dealer.</li> <li>7. Reduce load; use lower ground speed.</li> </ul>
Machine does not drive.	<ul style="list-style-type: none"> <li>1. Traction belt is worn, loose or broken.</li> <li>2. Traction belt is off pulley.</li> <li>3. Hydro fluid level low.</li> </ul>	<ul style="list-style-type: none"> <li>1. Contact Authorized Service Dealer.</li> <li>2. Contact Authorized Service Dealer.</li> <li>3. Add hydro fluid to reservoir.</li> </ul>
Abnormal vibration.	<ul style="list-style-type: none"> <li>1. Cutting blade(s) is/are bent or unbalanced.</li> <li>2. Blade mounting bolt is loose.</li> <li>3. Engine mounting bolts are loose.</li> <li>4. Loose engine pulley, idler pulley, or blade pulley.</li> <li>5. Engine pulley is damaged.</li> <li>6. Blade spindle bent.</li> </ul>	<ul style="list-style-type: none"> <li>1. Install new cutting blade(s).</li> <li>2. Tighten blade mounting bolt.</li> <li>3. Tighten engine mounting bolts.</li> <li>4. Tighten the appropriate pulley.</li> <li>5. Contact Authorized Service Dealer.</li> <li>6. Contact Authorized Service Dealer.</li> </ul>
Uneven cutting height.	<ul style="list-style-type: none"> <li>1. Blade(s) not sharp.</li> <li>2. Cutting blade(s) is/are bent.</li> <li>3. Mower is not level.</li> <li>4. Gage wheel not set correctly.</li> <li>5. Underside of mower is dirty.</li> <li>6. Tire pressure is incorrect.</li> <li>7. Blade spindle bent.</li> </ul>	<ul style="list-style-type: none"> <li>1. Sharpen blade(s).</li> <li>2. Install new cutting blade(s).</li> <li>3. Level mower from side-to-side and front-to-rear.</li> <li>4. Adjust gage wheel height.</li> <li>5. Clean the underside of the mower.</li> <li>6. Adjust tire pressure.</li> <li>7. Contact Authorized Service Dealer.</li> </ul>
Blades do not rotate.	<ul style="list-style-type: none"> <li>1. Drive belt is worn, loose or broken.</li> <li>2. Drive belt is off pulley.</li> <li>3. Deck belt is worn, loose or broken.</li> <li>4. Deck belt is off pulley.</li> </ul>	<ul style="list-style-type: none"> <li>1. Install new drive belt.</li> <li>2. Install drive belt and check adjusting shafts and belt guides for correct position.</li> <li>3. Install new deck belt.</li> <li>4. Install deck pulley and check the idler pulley, idler arm and spring for correct position and function.</li> </ul>







LCE

# The Toro Total Coverage Guarantee

## A Limited Warranty

### Conditions and Products Covered

The Toro Company and its affiliate, Toro Warranty Company, pursuant to an agreement between them, jointly promise to repair the listed Toro Products if defective in materials or workmanship. The following time periods apply from the date of purchase:

<u>Products</u>	<u>Warranty Period</u>
• All Products	1 year
• All Spindles	2 years parts and labor; third year, parts only
• Engines/Hydraulic Systems* on the following: Outfront and Mid-Mount Z's ProLine Mid-Size Mowers Groundsmaster® Riding Mowers Backpack Blowers	2 years
• Deck Shells (36"-72") on the following: ProLine Mid-Size Mowers Mid-Mount Z's	2 years
• Electric Clutch on 200 Series Mid-Mount Z's	2 years

This warranty includes the cost of parts and labor, but you must pay transportation costs.

This warranty applies to:

- Outfront and Mid-Mount Z's
- ProLine Mid-Size Mowers
- Groundsmaster Riding Mowers
- Turf Maintenance Equipment
- Debris Management Equipment

\* Some engines used on Toro LCE Products are warranted by the engine manufacturer.

### Instructions for Obtaining Warranty Service

If you think that your Toro Product contains a defect in materials or workmanship, follow this procedure:

1. Contact any Toro Authorized or Master Service Dealer to arrange service at their dealership. To locate a dealer convenient to you, access our website at [www.Toro.com](http://www.Toro.com). U.S. Customers may also call 800-348-2424.
2. Bring the product and your proof of purchase (sales receipt) to the Service Dealer.

If for any reason you are dissatisfied with the Service Dealer's analysis or with the assistance provided, contact us at:

LCB Customer Service Department  
Toro Warranty Company  
8111 Lyndale Avenue South  
Bloomington, MN 55420-1196  
888-577-7466 (U.S. customers)  
877-484-9255 (Canada customers)

### Countries Other than the United States or Canada

Customers who have purchased Toro products exported from the United States or Canada should contact their Toro Distributor (Dealer) to obtain guarantee policies for your country, province, or state. If for any reason you are dissatisfied with your Distributor's service or have difficulty obtaining guarantee information, contact the Toro importer. If all other remedies fail, you may contact us at Toro Warranty Company.

### Owner Responsibilities

You must maintain your Toro Product by following the maintenance procedures described in the operator's manual. Such routine maintenance, whether performed by a dealer or by you, is at your expense.

### Items and Conditions Not Covered

There is no other express warranty except for special emission system coverage on some products. This express warranty does not cover the following:

- Cost of regular maintenance service or parts, such as filters, fuel, lubricants, tune-up parts, blade sharpening, brake and clutch adjustments.
- Any product or part which has been altered or misused or required replacement or repair due to normal wear, accidents, or lack of proper maintenance.
- Repairs necessary due to improper fuel, contaminants in the fuel system, or failure to properly prepare the fuel system prior to any period of non-use over three months.
- Pickup and delivery charges.

All repairs covered by this warranty must be performed by an Authorized Toro Service Dealer using Toro approved replacement parts.

### General Conditions

Repair by an Authorized Toro Service Dealer is your sole remedy under this warranty.

Neither The Toro Company nor Toro Warranty Company is liable for indirect, incidental or consequential damages in connection with the use of the Toro Products covered by this warranty, including any cost or expense of providing substitute equipment or service during reasonable periods of malfunction or non-use pending completion of repairs under this warranty.

Some states do not allow exclusions of incidental or consequential damages, or limitations on how long an implied warranty lasts, so the above exclusions and limitations may not apply to you.

All implied warranties of merchantability (that the product is fit for ordinary use) and fitness for use (that the product is fit for a particular purpose) are limited to the duration of the express warranty.

This warranty gives you specific legal rights, and you may also have other rights which vary from state to state.