



Z257

**Z–Master[®] with 52 in. SFS Side Discharge
Mower**

Model No. 74230—Serial No. 230006001 and Up

Operator's Manual



Warning



The engine exhaust from this product contains chemicals known to the State of California to cause cancer, birth defects, or other reproductive harm.

Important This engine is not equipped with a spark arrester muffler. It is a violation of California Public Resource Code Section 4442 to use or operate this engine on any forest-covered, brush-covered or grass-covered land. Other states or federal areas may have similar laws.

This spark ignition system complies with Canadian ICES-002.

Ce système d'allumage par étincelle de véhicule est conforme à la norme NMB-002 du Canada.

The enclosed Engine Owner's Manual is supplied for information regarding The U.S. Environmental Protection Agency (EPA) and the California Emission Control Regulation of emission systems, maintenance and warranty.

Keep this engine Owner's Manual with your unit. Should this engine Owner's Manual become damaged or illegible, replace immediately. Replacements may be ordered through the engine manufacturer.

Contents

	Page
Introduction	3
Safety	3
Safe Operating Practices	3
Slope Chart	6
Safety and Instruction Decals	8
Gasoline and Oil	13
Recommended Gasoline	13
Using Stabilizer/Conditioner	13
Filling the Fuel Tank	13
Check Engine Oil Level	13
Setup	14
Loose Parts	14
Installing the Drive Wheels	14
Checking the Tire Pressure	14
Installing the Seat Retaining Rod	14
Installing the Motion Control Levers	15
Activating the Battery	15
Installing the Air Cleaner	16
Checking the Hydraulic Fluid	17
Greasing the Bearings	17
Checking the Side Discharge Chute	17

	Page
Checking the Level of Mower Deck	17
Checking the Engine Oil Level	17
Operation	18
Think Safety First	18
Controls	18
Operating the Parking Brake	19
Starting and Stopping the Engine	19
Operating the Power Take Off (PTO)	20
The Safety Interlock System	21
Driving Forward or Backward	21
Stopping the Machine	22
Adjusting the Height-of-Cut	22
Adjusting the Anti-Scalp Rollers	22
Positioning the Seat	23
Pushing the Machine by Hand	23
Using a Rollover Protection System (ROPS) ...	24
Transporting Machines	24
Loading Machines	24
Using the Z Stand	25
Tips for Mowing Grass	26
Maintenance	27
Recommended Maintenance Schedule	27
Servicing the Cutting Blades	28
Servicing the Air Cleaner	30
Servicing the Engine Oil	30
Servicing the Spark Plug	32
Servicing the Fuel Filter	32
Servicing the Fuel Tank	33
Greasing and Lubrication	33
Greasing the Bearings	34
Cleaning the Cooling Systems	34
Checking the Tire Pressure	35
Checking the Wheel Hub Slotted Nut	35
Adjusting the Caster Pivot Bearing	35
Servicing the Hydraulic System	36
Adjusting the Handle Neutral	37
Setting the Hydraulic Pump Neutral	38
Adjusting the Tracking	39
Replacing the Pump Drive Belt	40
Adjusting the Parking Brake	40
Servicing the Fuse	40
Servicing the Battery	41
Leveling the Mower	43
Cleaning Under the Deck	44
Inspecting the Belts	44
Replacing the Deck Belt	44
Replacing the PTO Drive Belt	45
Replacing the Grass Deflector	46
Waste Disposal	47

	Page
Mercury Tilt Switch	47
Disposing the Mercury Tilt Switch	47
Wiring Diagram	48
Cleaning and Storage	49
Troubleshooting	50
The Toro Total Coverage Guarantee	52

Introduction

Thank you for purchasing a Toro product.

All of us at Toro want you to be completely satisfied with your new product, so feel free to contact your local Authorized Service Dealer for help with service, genuine replacement parts, or other information you may require.

Whenever you contact your Authorized Service Dealer or the factory, always know the model and serial numbers of your product. These numbers will help the Service Dealer or Service Representative provide exact information about your specific product. You will find the model and serial number plate at the location shown in Figure 1.

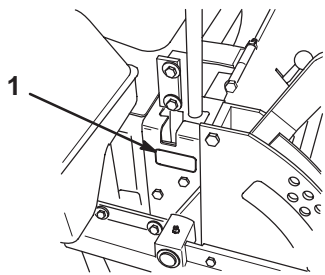

Figure 1

1. Model and serial number plate

For your convenience, write the product model and serial numbers in the space below.

<p>Model No. _____</p> <p>Serial No. _____</p>
--

Read this manual carefully to learn how to operate and maintain your product correctly. Reading this manual will help you and others avoid personal injury and damage to the product. Although we design, produce and market safe, state-of-the-art products, you are responsible for using the product properly and safely. You are also responsible for training persons, who you allow to use the product, about safe operation.

The warning system in this manual identifies potential hazards and has special safety messages that help you and others avoid personal injury, even death. **Danger**,

Warning, and **Caution** are signal words used to identify the level of hazard. However, regardless of the hazard, be extremely careful.

Danger signals an extreme hazard that will cause serious injury or death if the recommended precautions are not followed.

Warning signals a hazard that may cause serious injury or death if the recommended precautions are not followed.

Caution signals a hazard that may cause minor or moderate injury if the recommended precautions are not followed.

Two other words are also used to highlight information. **Important** calls attention to special mechanical information, and **Note** emphasizes general information worthy of special attention.

Determine the left and right side of the machine from the normal operating position.

Safety

This machine meets or exceeds the B71.4 1999 specifications of the American National Standards Institute, in effect at time of production.

Note: The addition of attachments made by other manufacturers that do not meet American National Standards Institute certification will cause noncompliance of this machine.

Improper use or maintenance by the operator or owner can result in injury. To reduce the potential for injury, comply with these safety instructions and always pay attention to the safety alert symbol, which means CAUTION, WARNING, or DANGER—“personal safety instruction.” Failure to comply with the instruction may result in personal injury or death.

This product is capable of amputating hands and feet and throwing objects. Always follow all safety instructions to avoid serious injury or death.

This product is designed for cutting and recycling grass or, when equipped with a grass bagger, for catching cut grass. Any use for purposes other than these could prove dangerous to user and bystanders.

Safe Operating Practices

The following instructions are from ANSI standard B71.4—1999.

Training

- Read the Operator's Manual and other training material. If the operator(s) or mechanic(s) can not read English it is the owner's responsibility to explain this material to them.
- Become familiar with the safe operation of the equipment, operator controls, and safety signs.
- All operators and mechanics should be trained. The owner is responsible for training the users.
- Never let children or untrained people operate or service the equipment. Local regulations may restrict the age of the operator.
- The owner/user can prevent and is responsible for accidents or injuries occurring to himself or herself, other people or property.

Preparation

- Evaluate the terrain to determine what accessories and attachments are needed to properly and safely perform the job. Only use accessories and attachments approved by the manufacturer.
- Wear appropriate clothing including hard hat, safety glasses and hearing protection. Long hair, loose clothing or jewelry may get tangled in moving parts.
- Inspect the area where the equipment is to be used and remove all objects such as rocks, toys and wire which can be thrown by the machine.
- Use extra care when handling gasoline and other fuels. They are flammable and vapors are explosive.
 - Use only an approved container
 - Never remove gas cap or add fuel with engine running. Allow engine to cool before refueling. Do not smoke.
 - Never refuel or drain the machine indoors.
- Check that operator's presence controls, safety switches and shields are attached and functioning properly. Do not operate unless they are functioning properly.

Operation

- Never run an engine in an enclosed area.
- Only operate in good light, keeping away from holes and hidden hazards.
- Be sure all drives are in neutral and parking brake is engaged before starting engine. Start the engine only from the operator's position.
- Never raise deck with the blades running.

- Never operate without the PTO shield, or other guards securely in place. Be sure all interlocks are functioning properly.
- Never operate with the discharge deflector raised, removed or altered, unless using a grass catcher.
- Do not change the engine governor setting or overspeed the engine.
- Stop on level ground, lower implements, disengage drives, engage parking brake, shut off engine before leaving the operator's position for any reason including emptying the catchers or unclogging the chute.
- Stop equipment and inspect blades after striking objects or if an abnormal vibration occurs. Make necessary repairs before resuming operations.
- Keep hands and feet away from the cutting units.
- Never carry passengers and keep pets and bystanders away.
- Be alert, slow down and use caution when making turns. Look behind and to the side before changing directions.
- Slow down and use caution when crossing roads and sidewalks. Stop blades if not mowing.
- Be aware of the mower discharge direction and do not point it at anyone.
- Do not operate the mower under the influence of alcohol or drugs.
- Use extreme care when loading or unloading the machine into a trailer or truck.
- Use care when approaching blind corners, shrubs, trees, or other objects that may obscure vision.

Slope Operation

- Do not mow slopes greater than 15 degrees.
- Do not mow near drop-offs, ditches, steep banks or water. Wheels dropping over edges can cause rollovers, which may result in serious injury, death or drowning.
- Do not mow slopes when grass is wet. Slippery conditions reduce traction and could cause sliding and loss of control.
- Do not make sudden turns or rapid speed changes.
- Use a walk behind mower and/or a hand trimmer near drop-offs, ditches, steep banks or water.
- Reduce speed and use extreme caution on slopes.
- Remove or mark obstacles such as rocks, tree limbs, etc. from the mowing area. Tall grass can hide obstacles.

- Watch for ditches, holes, rocks, dips, and rises that change the operating angle, as rough terrain could overturn the machine.
- Avoid sudden starts when mowing uphill because the mower may tip backwards.
- Be aware that loss of traction may occur going downhill. Weight transfer to the front wheels may cause drive wheels to slip and cause loss of braking and steering.
- Always avoid sudden starting or stopping on a slope. If tires lose traction, disengage the blades and proceed slowly off the slope.
- Follow the manufacturer's recommendations for wheel weights or counterweights to improve stability.
- Use extreme care with grass catchers or other attachments. These can change the stability of the machine and cause loss of control.
- Use care when checking blades. Wrap the blade(s) or wear gloves, and use caution when servicing them. Only replace blades. Never straighten or weld them.
- Keep hands and feet away from moving parts. If possible, do not make adjustments with the engine running.
- Charge batteries in an open well ventilated area, away from spark and flames. Unplug charger before connecting or disconnecting from battery. Wear protective clothing and use insulated tools.
- Keep all parts in good working condition and all hardware tightened. Replace all worn or damaged decals.
- Use only Toro-approved attachments. Warranty may be voided if used with unapproved attachments.

Using the Rollover Protection System (ROPS)

- A rollbar is available and its use is recommended for areas where there are slopes, drop-offs or water.
- When operating a machine with ROPS always use the seat belt.
- Be certain that the seat belt can be released quickly if the machine is driven or rolls into ponds or water.
- Check carefully for overhead clearances (i.e. branches, doorways, electrical wires) before driving under any objects and do not contact them.

Maintenance and storage

- Disengage drives, lower implement, set parking brake, stop engine and remove key or disconnect spark plug wire. Wait for all movement to stop before adjusting, cleaning or repairing.
- Clean grass and debris from cutting units, drives, mufflers, and engine to help prevent fires. Clean up oil or fuel spillage.
- Let engine cool before storing and do not store near flame.
- Shut off fuel while storing or transporting. Do not store fuel near flames or drain indoors.
- Park machine on level ground. Never allow untrained personnel to service machine.
- Use jack stands to support components when required.
- Carefully release pressure from components with stored energy.
- Disconnect battery or remove spark plug wire before making any repairs. Disconnect the negative terminal first and the positive last. Reconnect positive first and negative last.

Slope Chart

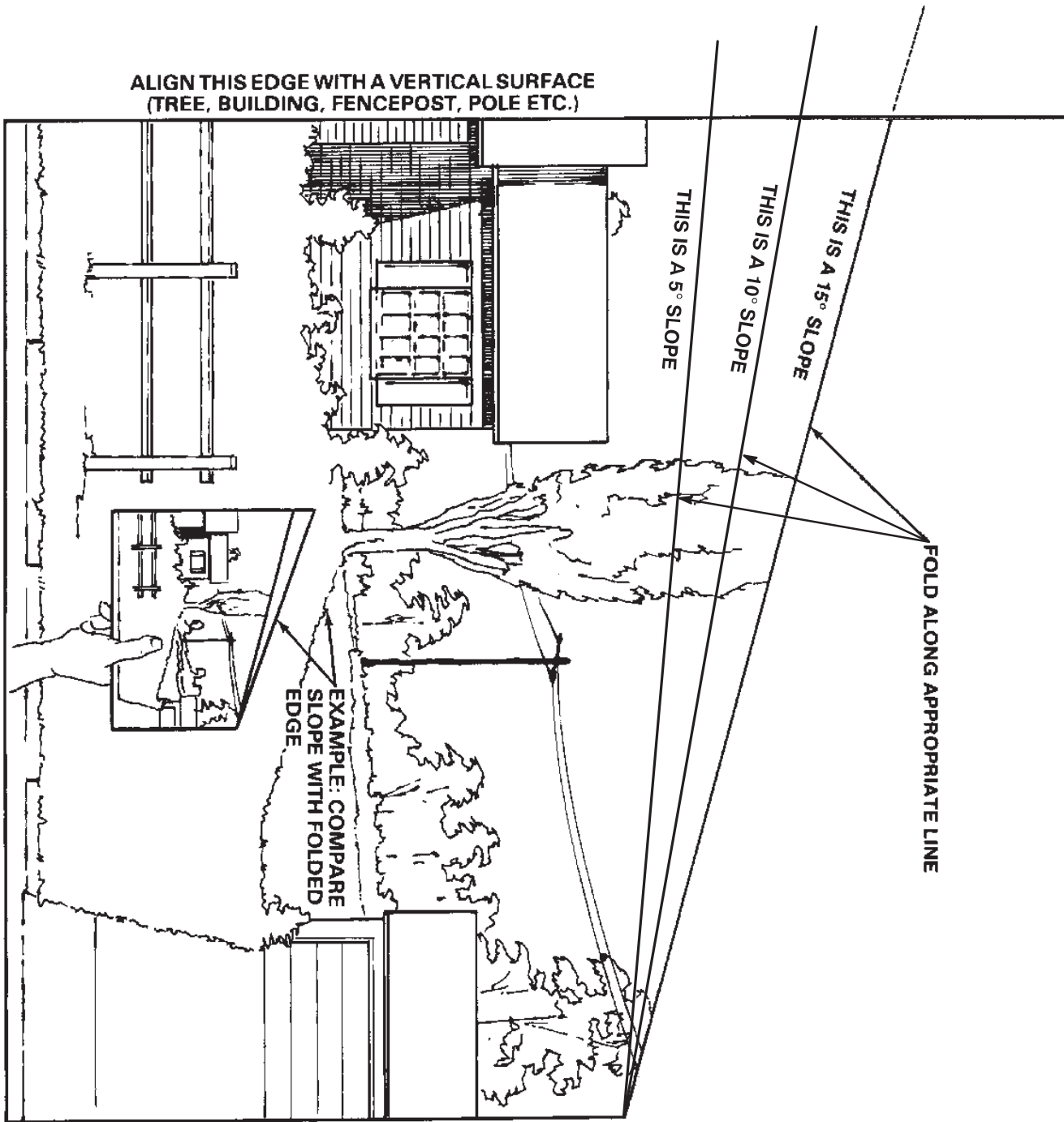

Safety and Instruction Decals



Safety decals and instructions are easily visible to the operator and are located near any area of potential danger. Replace any decal that is damaged or lost.

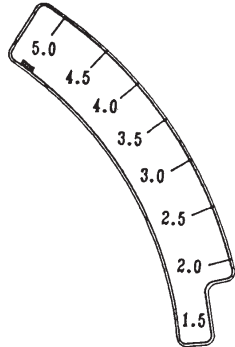

1-633345



1-523552

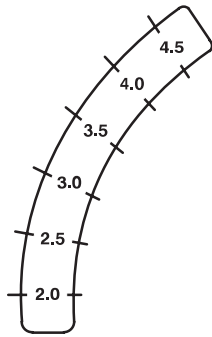

1-633706



1-633462

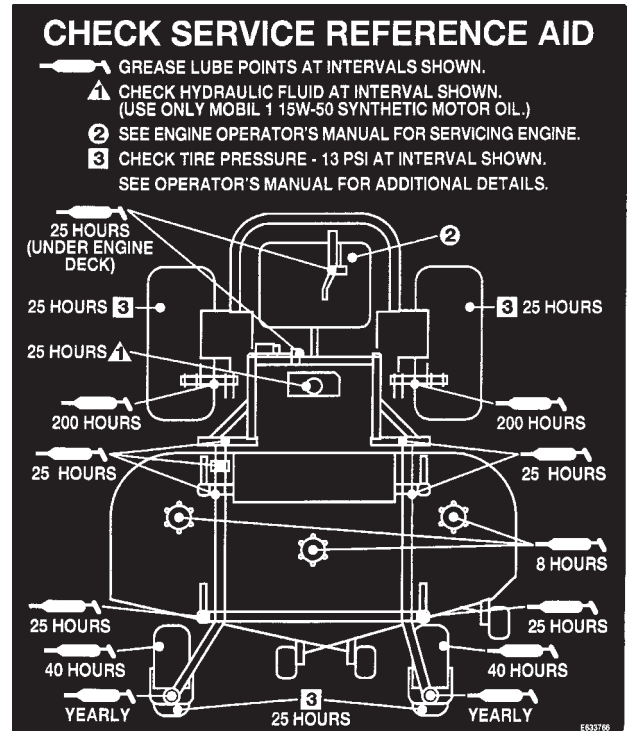

1-633766

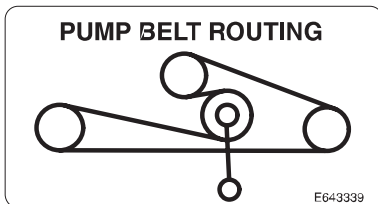

1-643339



1-643401

⚠ WARNING

- PARKING BRAKE MAY NOT HOLD MACHINE IF PARKED ON SLOPE.
- UNATTENDED UNIT MAY ROLL AWAY & CAUSE PERSONAL INJURY OR PROPERTY DAMAGE.
- DO NOT PARK ON SLOPES UNLESS WHEELS ARE CHOCKED OR BLOCKED.

E93818

1-633818



43-8480

⚠ DANGER

ROTATING BLADES UNDER ENTIRE MOWER DECK.
KEEP HANDS and FEET AWAY.
THROWN OBJECTS ARE DANGEROUS.
KEEP DEFLECTOR IN PLACE. KEEP BYSTANDERS AWAY.

66-1340

66-1340

⚠ DANGER

DO NOT OPERATE THIS UNIT UNLESS ALL SHIELDS ARE FIRMLY SECURED.

67-5360

67-5360



93-1122

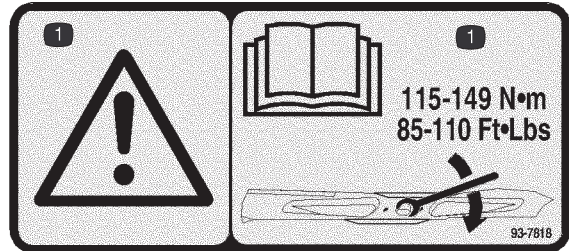

93-7818

1. Warning—read the *Operator's Manual* for instructions on torquing the blade bolt/nut to 115–149 N·m (85–110 ft.-lb).

ANTI-SCALP ROLLER ADJUSTMENT

FOR MAXIMUM DECK FLOTATION, PLACE ROLLERS IN POSITIONS SHOWN.

TURN ENGINE OFF BEFORE MAKING ROLLER ADJUSTMENTS.

- 1.5"/38mm
- 2.0"/51mm
- 2.5"/63mm
- 3.0"/76mm

98-3798

98-3798



98-4387

1. Warning—wear hearing protection.



98-5954

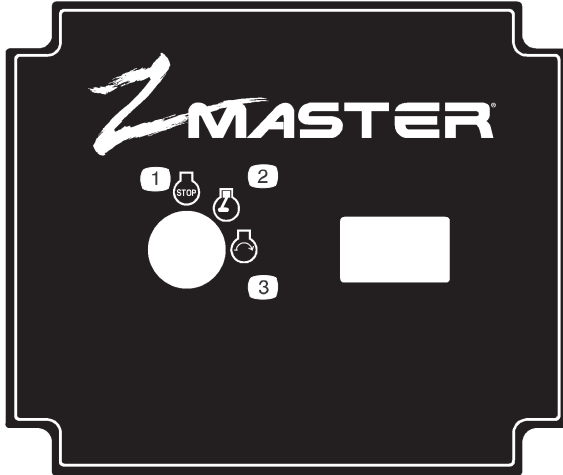

99-4632

- 1. Engine—stop
- 2. Engine—run
- 3. Engine—start

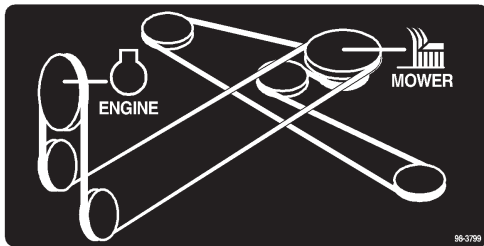

98-3799

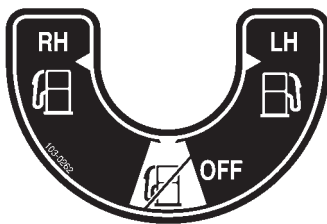

103-0262



103-0368

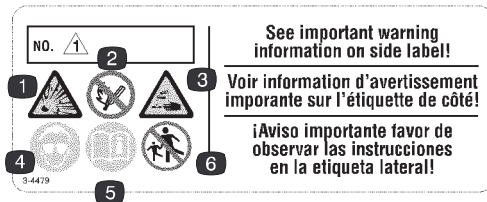

104-4163

- 1. Explosion hazard
- 2. No fire, open flames, or smoking.
- 3. Caustic liquid/chemical burn hazard
- 4. Wear eye protection
- 5. Read the *Operator's Manual*.
- 6. Keep bystanders a safe distance from the battery.



104-7759



104-8172



104-8569

MAINTENANCE FREE • SANS ENTRETIEN • LIBRE DE MANTENIMIENTO

NIVEAU MAXIMUM MAXIMUM FILL CAPACIDAD MAXIMA
 NIVEAU MINIMUM MINIMUM FILL CAPACIDAD MINIMA

⚠ DANGER/POISON ¡PELIGRO/VENENO!

<p>1</p>  <p>2</p> <p>RECYCLE • RECYCLER • RECICLAR</p>	<p>3</p> <p>SHIELD EYES. EXPLOSIVE GASES CAN CAUSE BLINDNESS OR INJURY.</p> <p>PROTÉGER LES YEUX. GAZ EXPLOSIFS PEUVENT RENDRE AVEUGLE OU PROVOQUER DES LÉSIONS.</p> <p>PROTEJA LOS OJOS. GASES EXPLOSIVOS PUEDEN CAUSAR CEGUERA O DAÑO.</p>	<p>4</p> <p>NO • SPARKS • FLAMES • SMOKING</p> <p>ÉLOIGNER • ÉTINCELLES • FLAMMES • CIGARETTES</p> <p>NO • CHISPAS • FLAMAS • FUMAR</p>	<p>5</p> <p>SULFURIC ACID CAN CAUSE BLINDNESS OR SEVERE BURNS.</p> <p>ACIDE SULFURIQUE PEUT RENDRE AVEUGLE OU PROVOQUER DES BRULURES GRAVES.</p> <p>ACIDO SULFURICO PUEDE CAUSAR CEGUERA O QUEMADURAS SEVERAS.</p>	<p>6</p> <p>FLUSH EYES IMMEDIATELY WITH WATER. GET MEDICAL HELP FAST.</p> <p>RINCER IMMEDIATEMENT LES YEUX A GRANDE EAU. CONTACTER RAPIDEMENT UN MEMBRE DE LA PROFESSION MEDICALE.</p> <p>LAVE LOS OJOS DE INMEDIATO. CONSIGA AYUDA MEDICA RAPIDO.</p>
--	--	---	--	--

KEEP OUT OF THE REACH OF CHILDREN. DO NOT TIP. DO NOT OPEN BATTERY!
 MAINTENIR HORS DE LA PORTÉE DES ENFANTS. NE RENVERSEZ PAS. N'OUVREZ PAS LA BATTERIE!
 MANTENGASE FUERA DEL ALCANCE DE LOS NIÑOS. NO INCLINE. NO ABRA LA BATERIA!

HOW TO ACTIVATE DRY CHARGED BATTERIES

- Use only battery electrolyte (1.265 Sp. Gr.) to fill battery initially.
- Do not overfill. Let stand for 15 minutes.
- Charge battery at 4-5 amps until specific gravity is 1.250 or higher and temperature is at least 60°F. – all cells gassing freely.
- After battery has been activated, add only water to replace normal loss.

3-1808 Dist. by:/por:/par: The Toro Company, Bloomington, MN 55420 MADE IN U.S.A. • FABRIQUE AUX E.U.A. • HECHO EN E.U.A.

104-4164

- | | | | |
|-----------------------------------|--|---|--|
| 1. Contains lead; do not discard. | 3. Wear eye protection; explosive gases can cause blindness and other injuries | 5. Sulfuric acid can cause blindness or severe burns. | 7. Maximum fill line |
| 2. Recycle | 4. No sparks, flame, or smoking | 6. Flush eyes immediately with water and get medical help fast. | 8. Minimum fill line |
| | | | 9. Instructions for activating the battery |

MOTION CONTROL



N R

CAUTION

Mercury in tilt switch is poisonous and can cause severe illness.
 * Never attempt to open or repair switch.
 * Avoid contact with mercury. See operator's manual for disposal guide.

MOTION CONTROL



N R

WARNING

Battery contains sulfuric acid. Avoid contact and always shield eyes, face, skin and clothing from battery. Cigarettes, flames or sparks could cause battery to explode. Do not charge or use booster cables or adjust post connections without proper training. In event of an accident, flush with water and call a physician immediately. Keep out of reach of children.

103-2433

DRIVE WHEEL RELEASE



Use 5/8 wrench
One turn counterclockwise to release
Do not over-tighten

103-2433

⚠ DANGER

- Mowing on wet grass or steep slopes can cause sliding and loss of control.
- Wheels dropping over edges can cause rollovers, which may result in serious injury, death or drowning.
- To avoid loss of control and possibility of rollover:
 - Do NOT mow near drop-offs or near water.
 - Do NOT mow slopes greater than 15°.
 - Reduce speed and use extreme caution on slopes.
 - Avoid sudden turns or rapid speed changes.
- A rollbar is available and its use is recommended for areas where there are slopes, drop-offs or water.



Greater than 15°



105-6571

106-6571

⇨ DISENGAGE

↑

↓

⇨ ENGAGE

(P) BRAKE

⚠ WARNING

To avoid serious injury or death:

- Read and understand the operator's manual before using this machine.
- Do not operate unless trained to safely use this machine.
- Do not operate under the influence of alcohol or drugs.
- Do not operate without shields, guards, and safety devices in place and working.
- Check the function of all safety interlocks daily.
- Do not defeat interlocks.
- Hearing protection is recommended.

For replacement manual, send model & serial number to: The Toro Co., 6111 Lyndale Ave. S., Bloomington, MN 55420.

THROTTLE

IMPORTANT: Before starting engine clean grass from pump drive belt compartment. Check more often in dry conditions.

⚠ DANGER

- Pick up objects that could be thrown by the blades.
- Never mow when bystanders are in the area.
- Never carry passengers.
- Lock behind and to the side before changing directions.
- Stop the engine and remove key before adjusting, servicing or cleaning machine and attachments.

Before leaving the operator's position:

- Stop the engine and disengage the blade.
- Move the levers out to the neutral lock position.
- Set the parking brake.
- Avoid blades unless engine and blades are stopped.

106-6570

Gasoline and Oil

Recommended Gasoline

Use UNLEADED Regular Gasoline suitable for automotive use (85 pump octane minimum). Leaded regular gasoline may be used if unleaded regular is not available.

Important Never use methanol, gasoline containing methanol, or gasohol containing more than 10% ethanol because the fuel system could be damaged. Do not mix oil with gasoline.



Danger



In certain conditions, gasoline is extremely flammable and highly explosive. A fire or explosion from gasoline can burn you and others and can damage property.

- Fill the fuel tank outdoors, in an open area, when the engine is cold. Wipe up any gasoline that spills.
- Never fill the fuel tank inside an enclosed trailer.
- Do not fill the fuel tank completely full. Add gasoline to the fuel tank until the level is 1/4 to 1/2 inch (6 to 13 mm) below the bottom of the filler neck. This empty space in the tank allows gasoline to expand.
- Never smoke when handling gasoline, and stay away from an open flame or where gasoline fumes may be ignited by a spark.
- Store gasoline in an approved container and keep it out of the reach of children. Never buy more than a 30-day supply of gasoline.
- Always place gasoline containers on the ground away from your vehicle before filling.
- Do not fill gasoline containers inside a vehicle or on a truck or trailer bed because interior carpets or plastic truck bed liners may insulate the container and slow the loss of any static charge.
- When practical, remove gas-powered equipment from the truck or trailer and refuel the equipment with its wheels on the ground.
- If this is not possible, then refuel such equipment on a truck or trailer from a portable container, rather than from a gasoline dispenser nozzle.
- If a gasoline dispenser nozzle must be used, keep the nozzle in contact with the rim of the fuel tank or container opening at all times until fueling is complete.



Warning



Gasoline is harmful or fatal if swallowed. Long-term exposure to vapors can cause serious injury and illness.

- Avoid prolonged breathing of vapors.
- Keep face away from nozzle and gas tank or conditioner opening.
- Keep gas away from eyes and skin.

Using Stabilizer/Conditioner

Use a fuel stabilizer/conditioner in the machine to provide the following benefits:

- Keeps gasoline fresh during storage of 90 days or less. For longer storage it is recommended that the fuel tank be drained.
- Cleans the engine while it runs
- Eliminates gum-like varnish buildup in the fuel system, which causes hard starting

Important Do not use fuel additives containing methanol or ethanol.

Add the correct amount of gas stabilizer/conditioner to the gas.

Note: A fuel stabilizer/conditioner is most effective when mixed with fresh gasoline. To minimize the chance of varnish deposits in the fuel system, use fuel stabilizer at all times.

Filling the Fuel Tank

1. Shut the engine off and set the parking brake.
2. Clean around each fuel tank cap and remove the cap. Add unleaded regular gasoline to both fuel tanks, until the level is 1/4 to 1/2 inch (6 mm to 13 mm) below the bottom of the filler neck. This space in the tank allows gasoline to expand. Do not fill the fuel tanks completely full.
3. Install fuel tank caps securely. Wipe up any gasoline that may have spilled.

Check Engine Oil Level

Before you start the engine and use the machine, check the oil level in the engine crankcase; refer to Checking Oil Level, page 31.

Setup

Loose Parts

Note: Use the chart below to verify all parts have been shipped.

DESCRIPTION	QTY.	USE
Rear Wheels	2	Installing wheels to traction unit
Retaining rod	1	Installing the seat retaining rod
Bolt, 5/16 x 1 inch	1	
Locknut, 5/16 inch	1	
Control lever—right	1	Installing the motion control levers
Control lever—left	1	
Bolt, 3/8 x 1 inch	4	
Spring washer, 3/8 inch	4	
Key	2	Read before operating machine
Operator's Manual	1	
Engine Operator's Manual	1	
Parts Catalog	1	
Registration card	1	

Installing the Drive Wheels

1. Uncrate the mower.
2. Remove wheel nuts from rear wheel hubs.
3. Align holes. Mount drive wheels with the valve stem to the outside of the traction unit.
4. Secure using wheel nuts provided. Torque to 95 ft-lb (128 N•m).

Important Make sure that wheel nuts are torqued to 95ft-lb (128 N•m).

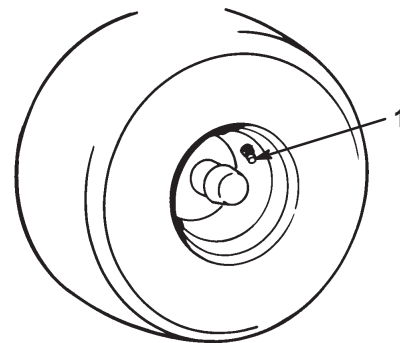

m-1872

Figure 2

1. Valve stem

Checking the Tire Pressure

Check the air pressure in the front and rear tires (Fig. 2).

Pressure: 13 psi (90 kPa)

Installing the Seat Retaining Rod

1. Tilt seat up. Remove locknut (5/16 inch) from bolt attaching seat retaining rod to seat frame (Fig. 3).
2. Remove retaining rod from seat and insert the **L** shaped end of the rod into the hole directly above the left-side hydraulic pump (Fig. 3).

- Place the seat retaining rod to the outside of the mounting tab of the seat frame and secure with one bolt (5/16 x 1 inch) and locknut (5/16 inch) (Fig. 3).
- Tighten until snug, then loosen so the rod pivots freely.

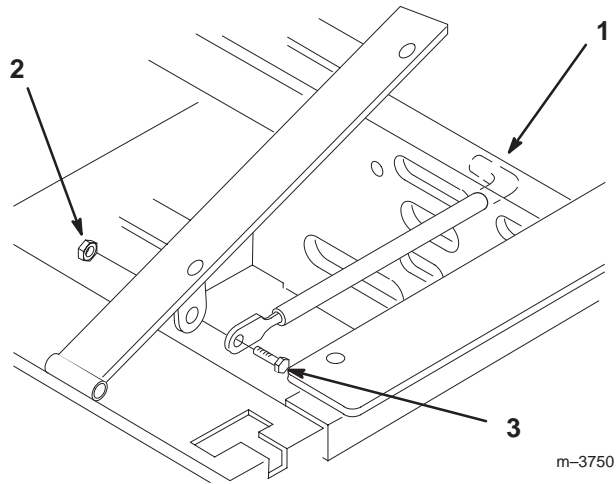

Figure 3

- L end of retaining rod
- Locknut, 5/16 inch
- Bolt, 5/16 x 1 inch

Installing the Motion Control Levers

There are two positions to install the control levers, high and low. Install levers in the top and middle holes for the high position. Install levers in the middle and bottom holes for the low position (Fig. 4).

- Remove the 4 bolts (3/8 x 1 inch) and 4 spring washers (3/8 inch) which attach the motion control levers to the control arm shafts for shipping (Fig. 4).
- Place the levers (with the mounting plate toward the rear) on the outside of the control arm shaft and secure with 4 bolts (3/8 x 1 inch) and 4 spring washers (3/8 inch) (Fig. 4).
- Position the levers so the bolts are in the center of the slots on the lever mounting plate and tighten until snug.
- Align the front/rear position of the levers, with each other, in the neutral position. Loosen hardware and adjustment by sliding/tilting the lever(s) forward or backward until properly aligned (Fig. 4).

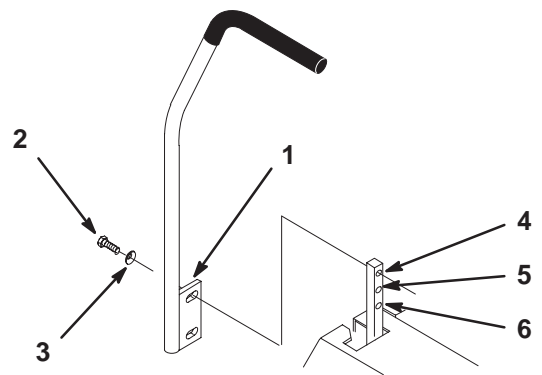

m-5596

Figure 4

- Mounting plate
- Bolt, 3/8 x 1 inch
- Spring washer, 3/8 inch
- Top hole
- Middle hole
- Bottom hole

- If the ends of the levers hit against each other, while in the drive position (Fig 5) (levers rotated in as far as possible) make adjustments by moving the levers outward to the neutral lock position and carefully bend them outward. Move them back to the drive position and check for clearance. Repeat if necessary.

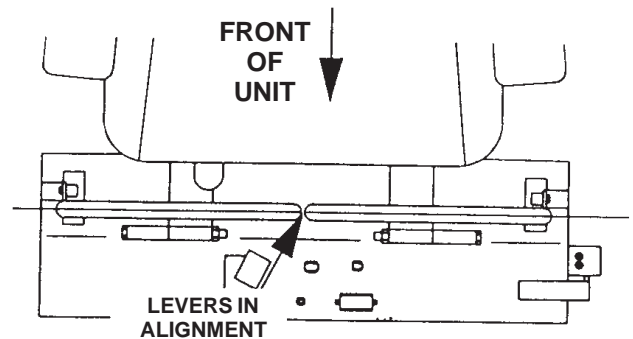

Figure 5

Activating the Battery

Bulk electrolyte with 1.265 specific gravity must be purchased from a local battery supply outlet.



Danger



Battery electrolyte contains sulfuric acid which is a deadly poison and causes severe burns.

- Do not drink electrolyte and avoid contact with skin, eyes or clothing. Wear safety glasses to shield your eyes and rubber gloves to protect your hands.
- Fill the battery where clean water is always available for flushing the skin.
- Follow all instructions and comply with all safety messages on the electrolyte container.

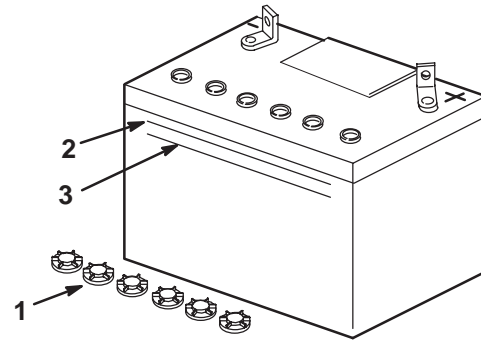

m-5004

Figure 6

1. Filler caps
2. Upper line
3. Lower line

1. Remove the battery from the machine. Refer to Removing the Battery on page 42.

2. Clean the top of the battery with a paper towel.

Note: Never fill the battery with electrolyte while the battery is installed in the machine. Electrolyte could be spilled on other parts and cause corrosion.

3. Remove the vent caps from the battery (Fig. 60).

4. Slowly pour electrolyte into each battery cell until the level is up to the **upper** line (Fig. 60) on the battery case.

Important Do not overfill the battery because electrolyte (sulfuric acid) can cause severe corrosion and damage to the chassis.

5. Wait five to ten minutes after filling the battery cells. Add electrolyte, if necessary, until the electrolyte level is up to the **upper** line (Fig. 60) on the battery case.

6. Reinstall battery filler caps.



Warning



Charging battery produces gasses that can explode and cause serious injury.

- Keep cigarettes, sparks and flames away from battery.
- Make sure the ignition switch is off.
- Ventilate when charging or using battery in an enclosed space.

7. Charge the battery. Refer to Charging the Battery on page 43.

8. Install the battery into the machine. Refer to Installing the Battery on page 41.

Note: Do not run the machine with the battery disconnected, electrical damage may occur.

Installing the Air Cleaner

1. Remove air cleaner from crate. Keep air cleaner and bracket together. (Fig. 7).

2. Remove the top two valve cover mounting screws from both valve covers (Fig. 7).

3. Place air cleaner onto engine and align holes in air cleaner bracket with holes in valve covers (Fig. 7).

4. Install valve cover screws into air cleaner bracket and valve covers (Fig. 7).

Important Tighten the valve cover screws to 70 in-lb (5 N•m) torque.

5. Remove plastic plugs from air intake elbow on engine and air cleaner hose (Fig. 7).
6. Install hose to air intake elbow on engine and air cleaner. Tighten hose clamps to secure the hose connections (Fig. 7).
7. With the air intake cap pointing upward, tighten the tensioning bolt until the clamp ends are a 1/2 inch (13 mm) apart (Fig. 7).

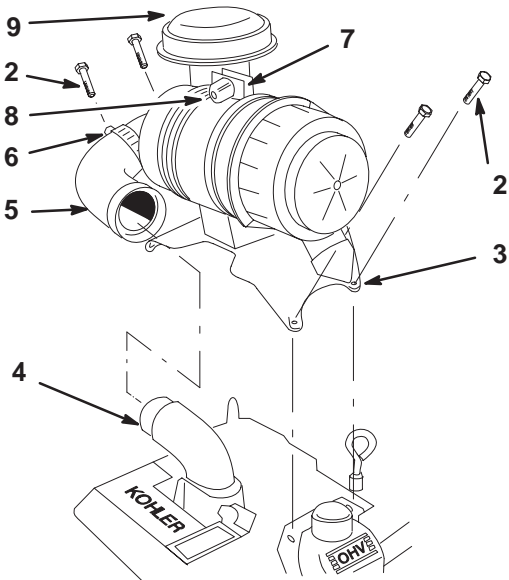

m-4810

Figure 7

- | | |
|--------------------------------|--------------------------------|
| 1. Air cleaner | 6. Hose clamp |
| 2. Valve cover mounting screws | 7. 1/2 inch between clamp ends |
| 3. Air cleaner bracket | 8. Tensioning bolt |
| 4. Air intake elbow | 9. Air intake cap |
| 5. Air cleaner hose | |

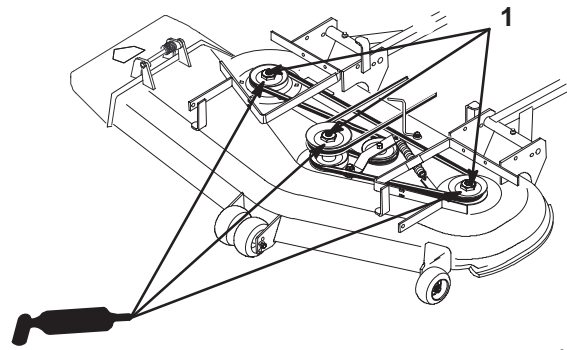

M-5035

Figure 8

1. Spindles

Checking the Side Discharge Chute

Remove plastic tie holding side discharge chute up and lower into place.

Checking the Level of Mower Deck

Check the level of the deck before the machine is first put in use.

Refer to Leveling the Mower on page 43.

Checking the Engine Oil Level

Before you start the engine and use the machine, check the oil level in the engine crankcase; refer to Checking Oil Level, page 31.

Checking the Hydraulic Fluid

Check the hydraulic fluid level before the engine is first started.

Refer to Checking the Hydraulic Fluid on page 36.

Greasing the Bearings

Important Make sure cutting unit spindles are full of grease before engine is first started.

Grease with No. 2 general purpose lithium base or molybdenum base grease.

1. Grease the fittings on the three spindle bearings. Grease until it comes out lower seals (Fig. 8).

Operation

Note: Determine the left and right sides of the machine from the normal operating position.

Think Safety First

Please read all safety instructions and symbols in the safety section. Knowing this information could help you or bystanders avoid injury.

! **Danger** !

Mowing on wet grass or steep slopes can cause sliding and loss of control.

Wheels dropping over edges can cause rollovers, which may result in serious injury, death or drowning.

A rollbar is available and its use is recommended for areas where there are slopes, drop-offs or water.

To avoid loss of control and possibility of rollover:

- **Do not mow near drop-offs or near water.**
- **Do not mow slopes greater than 15 degrees.**
- **Reduce speed and use extreme caution on slopes.**
- **Avoid sudden turns or rapid speed changes.**

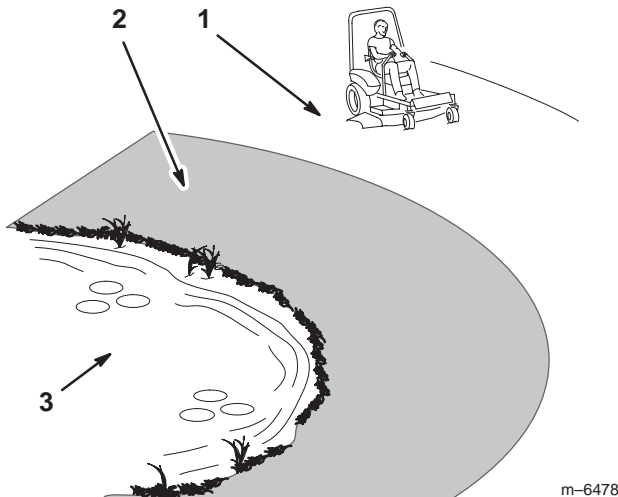

Figure 9

- | | |
|--|--|
| <ol style="list-style-type: none"> 1. Safe Zone—use the Z Master here on slopes less than 15 degrees or flat areas. | <ol style="list-style-type: none"> 2. Use walk behind mower and/or hand trimmer near drop-offs and water. 3. Water |
|--|--|

The use of protective equipment for eyes, ears, feet, and head is recommended.

! **Caution** !

This machine produces sound levels in excess of 85 dBA at the operator's ear and can cause hearing loss through extended periods of exposure.

Wear hearing protection when operating this machine.

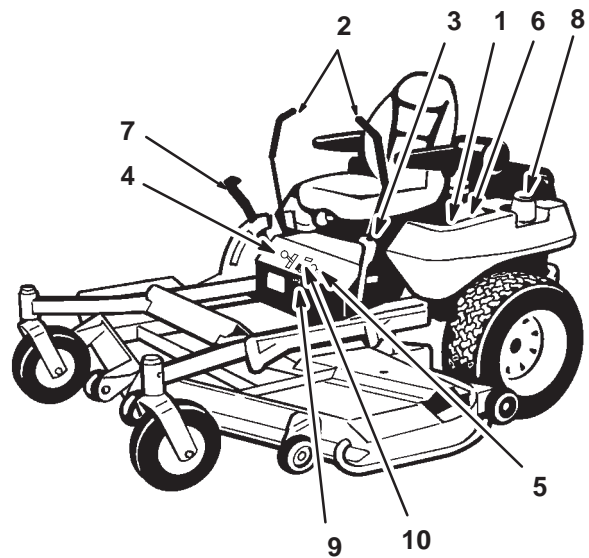

Figure 10

1. Warning—wear hearing protection.

Controls

Become familiar with all the controls (Fig. 11) before you start the engine and operate the machine.



M-4507

Figure 11

- | | |
|--|--|
| <ol style="list-style-type: none"> 1. Ignition switch 2. Motion control lever 3. Parking brake lever 4. Throttle 5. Choke | <ol style="list-style-type: none"> 6. Power take off (PTO) 7. Height-of-Cut lever 8. Fuel cap 9. Fuel shut off lever 10. Hour meter |
|--|--|

Using the Hour Meter

The hour meter records the number of hours the engine has operated. It operates when the engine is running. Use these times for scheduling regular maintenance.

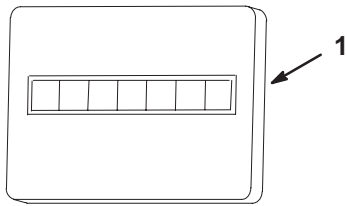

m-3077

Figure 12

1. Hour meter

Switching Fuel Tanks

The unit has two fuel tanks, located on the left and right sides. Each tank connects to the fuel shut off valve in the control panel. From there a common fuel line leads to the engine (Fig. 13).

To use the right side fuel tank rotate the fuel shut off valve 1/4 turn to the right from the off location. This uses fuel from the right side tank only. When the right hand fuel tank is empty, move the fuel shut off valve 1/4 turn to the left from the off position.

Close fuel shut off valve, on front panel before transporting or storing machine.

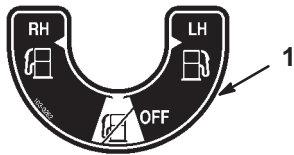

Figure 13

1. Shut off valve

Operating the Parking Brake

Always set the parking brake when you stop the machine or leave it unattended.

Setting the Parking Brake

1. Move the motion control levers (Fig. 11) out to the neutral lock position.
2. Pull back and up on the parking brake lever to set the parking brake (Fig. 14). The parking brake lever should stay firmly in the engaged position.

⚠Warning⚠

Parking brake may not hold machine parked on a slope and could cause personal injury or property damage.

Do not park on slopes unless wheels are chocked or blocked

Releasing the Parking Brake

1. Push forward and down on the parking brake lever to release the parking brake (Fig. 14). The parking brake is disengaged and the lever rests against the brake stop.

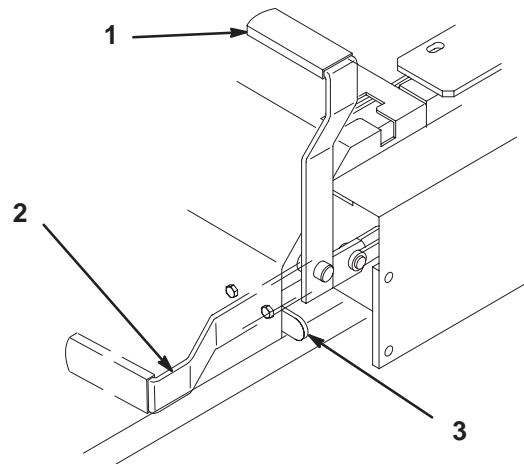

Figure 14

1. Parking brake-ON
2. Parking brake-OFF
3. Brake Stop

Starting and Stopping the Engine

Starting the Engine

1. Sit on the seat and move the motion controls to neutral locked position.
2. Set the parking brake; refer to Setting the Parking Brake, page 19.
3. Move the PTO (power take off) switch to off (Fig. 15).
4. Move the choke control to the **on** position before starting a cold engine.

Note: A warm or hot engine may not require choking. After engine starts, move choke control to the **off** position.

5. Move the throttle control to the **fast** position before starting a cold engine.

- Turn ignition key to **start** to energize starter. When the engines starts, release the key.

Important Do not engage starter for more than 10 seconds at a time. If engine fails to start allow 30 second cool-down period between attempts. Failure to follow these instructions can burn out starter motor.

- After the engine starts, move the choke to **off** (Fig. 16). If the engine stalls or hesitates, move the choke back to **on** for a few seconds. Then move the throttle lever to desired setting. Repeat this as required.

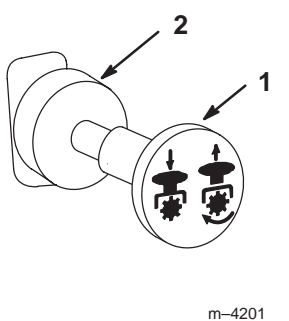

Figure 15

- PTO-On
- PTO-Off

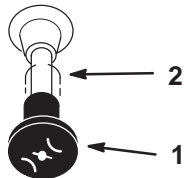

Figure 16

- Choke-On
- Choke-Off

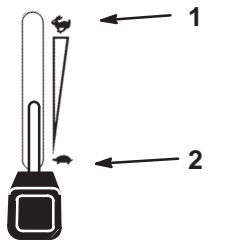

Figure 17

- Throttle-Fast
- Throttle-Slow

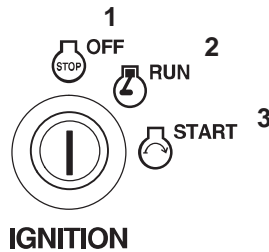

Figure 18

- Off
- Run
- Start

- Pull wire off spark plug(s) to prevent possibility of someone accidentally starting the machine before transporting or storing machine.
- Close fuel shut off valve, on front panel before transporting or storing machine.

Important Make sure that the fuel shut off valve is closed before transporting or storing the machine, as fuel leakage may occur. Set the parking brake before transporting. Make sure to remove the key as the fuel pump may run and cause the battery to lose charge.

Caution

Children or bystanders may be injured if they move or attempt to operate the tractor while it is unattended.

Always remove the ignition key and set the parking brake when leaving the machine unattended, even if just for a few minutes.

Operating the Power Take Off (PTO)

The power take off (PTO) switch engages and disengages power to the electric clutch.

Engaging the PTO

- While seated in the seat, release pressure on the traction control levers and place in neutral.
- Place throttle to the fast position.
- Pull out on the power take off (PTO) switch to engage (Fig. 19).

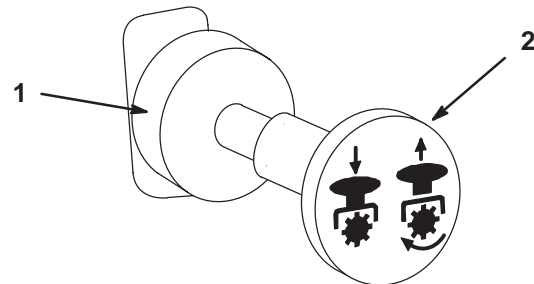

Figure 19

- PTO - Off
- PTO - On



Stopping the Engine

- Push the PTO to off (Fig. 17).
- Move the throttle lever midway between the slow and fast positions (Fig. 17).
- Let the engine idle for 60 seconds (Fig. 18).
- Turn the ignition key to off (Fig. 18).

Disengaging the PTO

- To disengage push the PTO switch to the off position (Fig. 19).

The Safety Interlock System

 **Caution** 

If safety interlock switches are disconnected or damaged the machine could operate unexpectedly causing personal injury.

- **Do not tamper with the interlock switches.**
- **Check the operation of the interlock switches daily and replace any damaged switches before operating the machine.**

Understanding the Safety Interlock System

The safety interlock system is designed to prevent the engine from starting unless:

- You are sitting on the seat.
- The parking brake is engaged.
- The power take off (PTO) is disengaged.
- The motion control levers are in neutral locked position.

The safety interlock system also is designed to stop the engine when the traction controls are moved from the locked position with the parking brake **engaged** or if you rise from the seat when the PTO is **on** engaged.

Testing the Safety Interlock System

Test the safety interlock system before you use the machine each time. If the safety system does not operate as described below, have an Authorized Service Dealer repair the safety system immediately.



1. Sitting on the seat, engage the parking brake and move PTO to on. Try starting the engine; the engine should not crank.
2. Sitting on the seat, engage the parking brake and move PTO to off. Move either motion control lever (out of neutral locked position). Try starting the engine; the engine should not crank. Repeat for other control lever.
3. Sitting on the seat, engage the parking brake, move PTO switch to off and move the motion control levers to neutral lock position. Now start the engine. While

the engine is running, release the parking brake, engage the PTO and rise slightly from the seat; the engine should stop.

4. Sitting on the seat, engage the parking brake, move PTO switch to off and move the motion control levers to neutral lock position. Now start the engine. While the engine is running, center either motion control and move (forward or reverse); the engine should stop. Repeat for other motion control.
5. Sitting on the seat, disengage the parking brake, move PTO switch to off and move the motion control levers to neutral lock position. Try starting the engine; the engine should not crank.

Driving Forward or Backward

The throttle control regulates the engine speed as measured in rpm (revolutions per minute). Place the throttle control in the fast position for best performance. Always operate in the full throttle position when mowing.

 **Caution** 

Machine can spin very rapidly. Operator may lose control of machine and cause personal injury or damage to machine.

- **Use caution when making turns.**
- **Slow the machine down before making sharp turns.**

Driving Forward

1. Release the parking brake; refer to Releasing the Parking Brake, page 19.
2. Move levers to the center, un-locked position.
3. To go forward, slowly push the motion control levers forward (Fig. 20).

Note: Engine will kill if traction control levers are moved with parking brake engaged.

To go straight, apply equal pressure to both motion control levers (Fig. 20).

To turn, move the motion control lever toward neutral in the direction you want to turn (Fig. 20).

The farther you move the traction control levers in either direction, the faster the machine will move in that direction.

To stop pull the motion control levers to neutral.

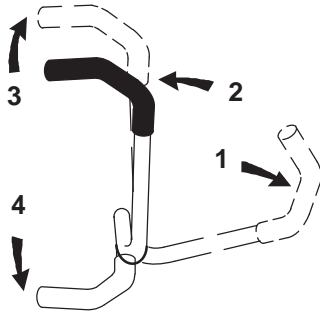

m-2715

Figure 20

- | | |
|---|-------------|
| 1. Motion control lever-neutral lock position | 3. Forward |
| 2. Center un-lock position | 4. Backward |

Driving Backward

1. Move levers to the center, un-locked position.
2. To go backward, slowly pull the motion control levers rearward (Fig. 20).

To go straight, apply equal pressure to both motion control levers (Fig. 20).

To turn, release pressure on the motion control lever toward the direction you want to turn (Fig. 20).

To stop push the motion control levers to neutral.

Stopping the Machine

To stop the machine, move the traction control levers to neutral and move to locked position, disengage the power take off (PTO), and turn the ignition key to off. Also set the parking brake when you leave the machine; refer to Setting the Parking Brake, page 19. Remember to remove the key from the ignition switch.



Caution



Children or bystanders may be injured if they move or attempt to operate the tractor while it is unattended.

Always remove the ignition key and set the parking brake when leaving the machine unattended, even if just for a few minutes.

Adjusting the Height-of-Cut

The height-of-cut is adjusted from 1-1/2 to 5 inch (38 to 127 mm) in 1/4 inch (6 mm) increments by relocating clevis pin in different hole locations.

1. Raise the height-of-cut lever to the transport position (also the 5 inch (127 mm) cutting height position) (Fig. 21).
2. To adjust, remove hairpin cotter and clevis pin from height-of-cut bracket (Fig. 21).
3. Select hole in height-of-cut bracket corresponding to the height-of-cut desired and, insert clevis pin (Fig. 21).
4. Secure clevis pin with hairpin cotter (Fig. 21).
5. Move lever to selected height.

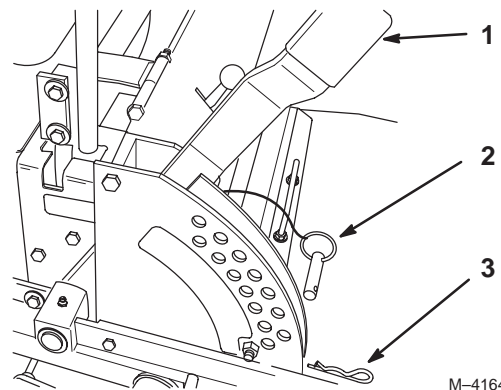

M-4164

Figure 21

- | | |
|------------------------|-------------------|
| 1. Height of cut lever | 3. Hairpin Cotter |
| 2. Clevis Pin | |

Adjusting the Anti-Scalp Rollers

Whenever you change the height-of-cut it is recommended to adjust the height of the anti-scalp rollers.

1. Disengage the power take off (PTO) and turn the ignition key to off. Move levers to neutral locked position and apply parking brake. Remove the key.
 2. After adjusting height-of-cut remove flange nut and spring disk while holding stud with wrench (Fig. 22).
- Note:** Do not remove the wheel nut and washer (Fig. 22).
3. Select hole so gage wheel is positioned to the nearest corresponding height-of-cut desired (Fig. 22).
 4. Reinstall the flange nut and spring disk. Torque to 40–45 ft–lb (54.2–61.0 N•m) (Fig. 22).

5. Repeat adjustment on other gage wheels.

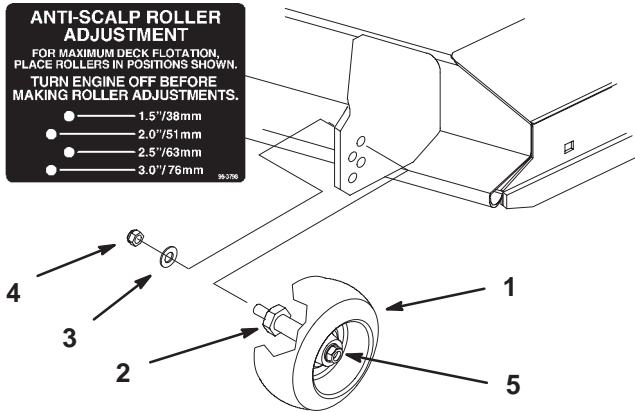

Figure 22

- | | |
|----------------|---|
| 1. Gage Wheel | 4. Flange Nut |
| 2. Stud | 5. Wheel nut and washer. Do Not Remove. |
| 3. Spring Disk | |

Positioning the Seat

The seat can move forward and backward. Position the seat where you have the best control of the machine and are most comfortable.

1. To adjust, move the lever sideways to unlock seat (Fig. 23).
2. Slide the seat to the desired position and release lever to lock in position.

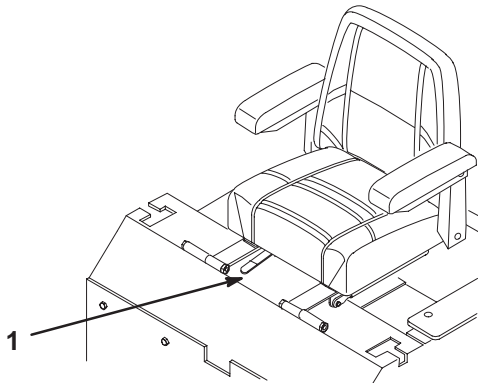

Figure 23

1. Adjustment lever

Pushing the Machine by Hand

Important Always push the machine by hand. Never tow the machine because hydraulic damage may occur.

To Push the Machine

1. Disengage the power take off (PTO) and turn the ignition key to off. Move levers to neutral locked position and apply parking brake.
2. Rotate the by-pass valves counterclockwise 1 turn to push. This allows hydraulic fluid to by-pass the pump enabling the wheels to turn (Fig. 24).

Important Do not rotate by-pass valves more than 1 turn. This prevents valves from coming out of the body and causing fluid to run out.

3. Disengage parking brake before pushing.

To Operate the Machine

1. Rotate the by-pass valves clockwise 1 turn to operate machine (Fig. 24).

Note: Do not over tighten the by-pass valves.

Note: The machine will not drive unless by-pass valves are turned in.

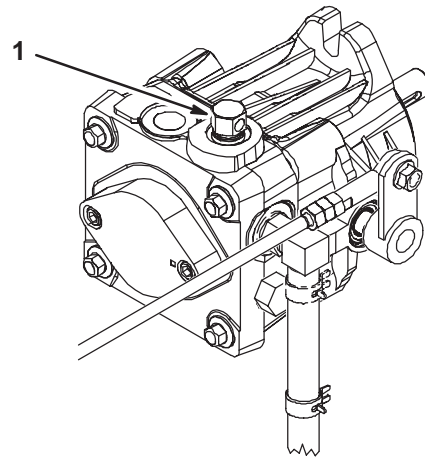

Figure 24

1. By-pass valve

Using a Rollover Protection System (ROPS)

A ROPS is available and its use is recommended for areas where there are slopes, drop-offs or water. Contact an Authorized Service Dealer for information on obtaining ROPS for your machine.

Important When operating a machine with ROPS always use the seat belt.

Transporting Machines

Use a heavy-duty trailer or truck to transport the machine. Ensure that the trailer or truck has all necessary lighting and marking as required by law. Please carefully read all the safety instructions in the safety section. Knowing this information could help you, your family, pets or bystanders avoid injury.

To transport the machine:

- Lock brake and block wheels.
- Securely fasten the machine to the trailer or truck with straps, chains, cable, or ropes.
- Secure a trailer to towing vehicle with safety chains.

Warning

Driving on street or roadway without turn signals, lights, reflective markings, or a slow moving vehicle emblem is dangerous and can lead to accidents causing personal injury.

Do not drive machine on a public street or roadway.

Loading Machines

Use extreme caution when loading units on trailers or trucks. One full width ramp that is wide enough to extend beyond the rear tires is recommended instead of individual ramps for each side of the unit (Fig. 25). The lower rear section of the tractor frame extends back between the rear wheels and serves as a stop for tipping backward. Having a full width ramp provides a surface for the frame members to contact if the unit starts to tip backward. If it is not possible to use one full width ramp, use enough individual ramps to simulate a full width continuous ramp.

The ramp should be long enough so that the angles do not exceed 15 degrees (Fig. 25). A steeper angle may cause mower deck components to get caught as the unit moves from ramp to trailer or truck. Steeper angles may also cause the unit to tip backward. If loading on or near a

slope, position the trailer or truck so it is on the down side of the slope and the ramp extends up the slope. This will minimize the ramp angle. The trailer or truck should be as level as possible.

Important Do Not attempt to turn the unit while on the ramp; you may lose control and drive off the side.

Avoid sudden acceleration when driving up a ramp and sudden deceleration when backing down a ramp. Both maneuvers can cause the unit to tip backward.

Warning

Loading a unit onto a trailer or truck increases the possibility of backward tip-over and could cause serious injury or death.

- Use extreme caution when operating a unit on a ramp.
- Use only a single, full width ramp; DO NOT use individual ramps for each side of the unit.
- If individual ramps must be used, use enough ramps to create an unbroken ramp surface wider than the unit.
- Do not exceed a 15 degree angle between ramp and ground or between ramp and trailer or truck.
- Avoid sudden acceleration while driving unit up a ramp to avoid tipping backward.
- Avoid sudden deceleration while backing unit down a ramp to avoid tipping backward.

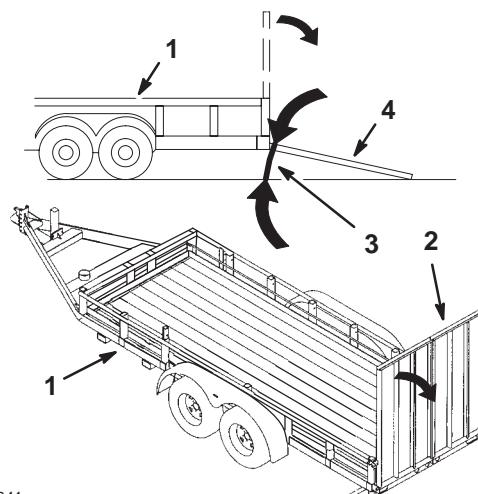

m-6841

Figure 25

1. Trailer
2. Full width ramp
3. Not greater than 15 degrees
4. Full width ramp—side view

Using the Z Stand

The Z Stand[®] is used for raising the front end of the machine. This allows for cleaning of the deck and removal of the blades.

! **Warning** !

Unit could fall onto someone and cause serious injury or death.

- Use extreme caution when operating unit on Z Stand.
- Use only for cleaning deck and removing blades.
- Do not keep unit on Z Stand for extended periods of time.
- Always shut engine off and set parking brake before performing any maintenance to deck.

Driving up onto the Z Stand

Important Use the Z Stand on a level surface.

1. Raise deck to transport position.
2. Remove bracket pin (Fig. 26).

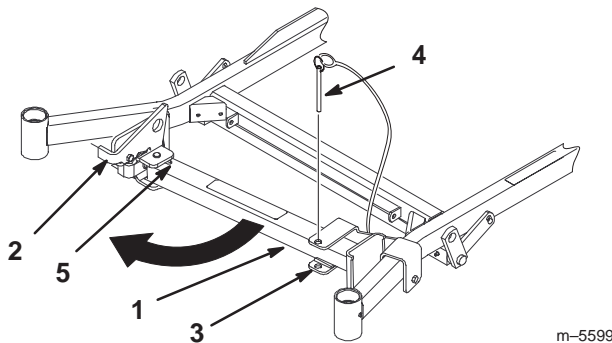
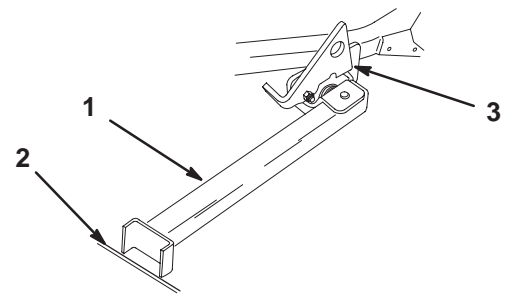

Figure 26

- | | |
|------------|-------------------|
| 1. Z Stand | 4. Bracket Pin |
| 2. Latch | 5. Bottom of slot |
| 3. Bracket | |



m-5600

Figure 27

- | | |
|---------------------------------|-------------------------------|
| 1. Z Stand (Positioned in slot) | 2. Crack in side walk or turf |
| | 3. Latch resting on pivot tab |
3. Raise latch. Swing stand foot out front and slide stand toward machine, into the bottom of slot (Fig. 26 and 27).
 4. Set foot of stand on the ground and rest latch on pivot tab (Fig. 27).
 5. Start engine and put at half throttle.
- Note:** For best results, place foot of stand into seams in sidewalks or into turf (Fig. 27).
6. Drive onto stand. Stop when latch drops over tab into locked position (Fig. 27). Once onto stand, engage parking brake. Shut off engine.
 7. Chock or block the drive wheels.

! **Warning** !

Parking brake may not hold machine parked on Z Stand and could cause personal injury or property damage.

Do not park on Z Stand unless wheels are chocked or blocked.

8. Perform maintenance.
9. Remove chocks or blocks.

Driving off the Z Stand

1. Raise latch to unlocked position (Fig. 28).
2. Start engine and place at half throttle. Disengage parking brake.
3. Slowly drive backwards off of stand.
4. Return stand to its rest position (Fig. 26).

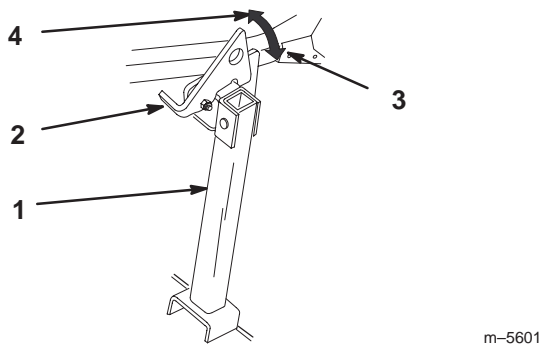

Figure 28

- | | |
|------------|----------------------|
| 1. Z Stand | 3. Locked position |
| 2. Latch | 4. Unlocked position |

m-5601

Tips for Mowing Grass

Fast Throttle Setting

For best mowing and maximum air circulation, operate the engine at fast. Air is required to thoroughly cut grass clippings, so do not set the height-of-cut so low as to totally surround the mower by uncut grass. Always try to have one side of the mower free from uncut grass, which allows air to be drawn into the mower.

Cutting a Lawn for the First Time

Cut grass slightly longer than normal to ensure the cutting height of the mower does not scalp any uneven ground. However, the cutting height used in the past is generally the best one to use. When cutting grass longer than six inches tall, you may want to cut the lawn twice to ensure an acceptable quality of cut.

Cut 1/3 of the Grass Blade

It is best to cut only about 1/3 of the grass blade. Cutting more than that is not recommended unless grass is sparse, or it is late fall when grass grows more slowly.

Mowing Direction

Alternate mowing direction to keep the grass standing straight. This also helps disperse clippings which enhances decomposition and fertilization.

Mow at Correct Intervals

Normally, mow every four days. But remember, grass grows at different rates at different times. So to maintain the same cutting height, which is a good practice, mow more often in early spring. As the grass growth rate slows in mid summer, mow less frequently. If you cannot mow for an extended period, first mow at a high cutting height; then mow again two days later at a lower height setting.

Cutting Speed

To improve cut quality, use a slower ground speed in certain conditions.

Avoid Cutting Too Low

If the cutting width of the mower is wider than the mower you previously used, raise the cutting height to ensure that uneven turf is not cut too short.

Long Grass

If the grass is ever allowed to grow slightly longer than normal, or if it contains a high degree of moisture, raise the cutting height higher than usual and cut the grass at this setting. Then cut the grass again using the lower, normal setting.

When Stopping

If the machine's forward motion must be stopped while mowing, a clump of grass clippings may drop onto your lawn. To avoid this, move onto a previously cut area with the blades engaged.

Keep the Underside of the Mower Clean

Clean clippings and dirt from the underside of the mower after each use. If grass and dirt build up inside the mower, cutting quality will eventually become unsatisfactory.

Blade Maintenance



Maintain a sharp blade throughout the cutting season because a sharp blade cuts cleanly without tearing or shredding the grass blades. Tearing and shredding turns grass brown at the edges, which slows growth and increases the chance of disease. Check the cutter blades daily for sharpness, and for any wear or damage. File down any nicks and sharpen the blades as necessary. If a blade is damaged or worn, replace it immediately with a genuine TORO replacement blade.

Maintenance

Recommended Maintenance Schedule

Maintenance Service Interval	Maintenance Procedure
After first 5 hours	<ul style="list-style-type: none"> Hydraulic fluid—check level Engine Oil—change Hydraulic filter—change
Each Use	<ul style="list-style-type: none"> Oil—check level Safety System—check Mower Housing—clean Engine Cooling System—clean¹
Every 5 Hours	<ul style="list-style-type: none"> Cutting Blades—check Blade Spindle Bearings—grease
Every 25 Hours	<ul style="list-style-type: none"> Chassis—grease¹ Linkage bushings—oil¹ Hydraulic fluid—check level Foam Air Cleaner—service¹ Battery—check electrolyte
Every 50 Hours	<ul style="list-style-type: none"> Belts—check for wear/cracks Tires—check pressure
Every 100 Hours	<ul style="list-style-type: none"> Paper Air Cleaner—replace¹ Engine Oil—change¹ Hydraulic lines—check Engine Cooling System—clean¹
Every 200 Hours	<ul style="list-style-type: none"> Oil Filter—change (200 hours or every other oil change)¹ Hydraulic filter—change Spark Plug(s)—check Fuel Filter—replace
Every 500 Hours or at Storage	<ul style="list-style-type: none"> Caster Pivot— adjustment Wheel Hub Slotted Nut— adjustment
Before Storage Service	<ul style="list-style-type: none"> Battery—charge, Disconnect cables Gasoline—drain Chipped Surfaces—paint Perform all maintenance procedures listed above before storage

¹More often in dusty, dirty conditions

Caution

If you leave the key in the ignition switch, someone could accidentally start the engine and seriously injure you or other bystanders.

Remove the key from the ignition and disconnect the wire from the spark plug(s) before you do any maintenance. Set the wire aside so that it does not accidentally contact the spark plug.

Servicing the Cutting Blades

Maintain sharp blades throughout the cutting season because sharp blades cut cleanly without tearing or shredding the grass blades. Tearing and shredding turns grass brown at the edges, which slows growth and increases the chance of disease.

Check the cutter blades daily for sharpness, and for any wear or damage. File down any nicks and sharpen the blades as necessary. If a blade is damaged or worn, replace it immediately with a genuine TORO replacement blade. For convenient sharpening and replacement, you may want to keep extra blades on hand.

⚠
Danger
⚠

A worn or damaged blade can break, and a piece of the blade could be thrown into the operator's or bystander's area, resulting in serious personal injury or death.

- Inspect the blade periodically for wear or damage.
- Replace a worn or damaged blade.

Before Inspecting or Servicing the Blades

Disengage the blade control (PTO) and set the parking brake. Turn the ignition key to off. Remove the key and disconnect the spark plug wire(s) from the spark plug(s).

Inspecting the Blades

1. Inspect the cutting edges (Fig 29). If the edges are not sharp or have nicks, remove and sharpen the blades. Refer to Sharpening the Blades on page 29.
2. Inspect the blades, especially the curved area (Fig. 29). If you notice any damage, wear, or a slot forming in this area (item 3 in Fig. 29), immediately install a new blade.

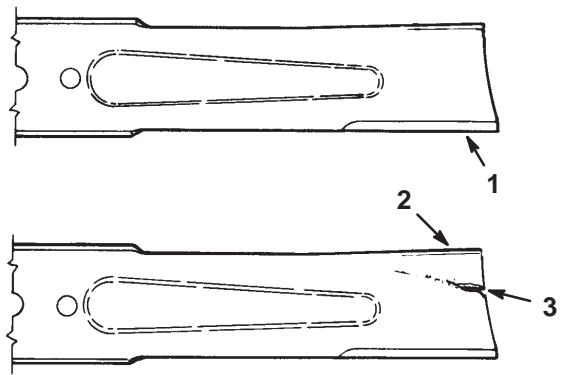

m-151

Figure 29

1. Cutting Edge
2. Curved Area
3. Wear/slot Forming

Checking for Bent Blades

1. Rotate the blades until the ends face forward and backward (Fig. 30). Measure from a level surface to the cutting edge of the blades (Fig. 31). Note this dimension.

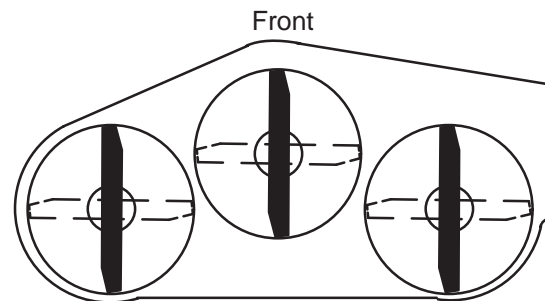

m-1078

Figure 30

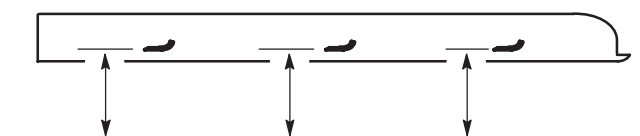

MEASURE FROM CUTTING EDGE TO A LEVEL SURFACE

m-2539

Figure 31

2. Rotate the opposite ends of the blades forward.
3. Measure from a level surface to the cutting edge of the blades at the same position as in step 1 above. The difference between the dimensions obtained in steps 1 and 2 must not exceed 1/8 inch (3 mm). If this

dimension exceeds 1/8 inch (3 mm), the blade is bent and must be replaced. Refer to Removing the Blades, and Installing the Blades on page 29.

Warning

A blade that is bent or damaged could break apart and could seriously injure or kill you or bystanders.

- Always replace bent or damaged blade with a new blade.
- Never file or create sharp notches in the edges or surfaces of blade.

Removing the Blades

Blades must be replaced if a solid object is hit, if the blade is out of balance or is bent. To ensure optimum performance and continued safety conformance of the machine, use genuine TORO replacement blades. Replacement blades made by other manufacturers may result in non-conformance with safety standards.

Warning

Contact with sharp blade can cause serious injury.

Wear gloves or wrap sharp edges of the blade with a rag.

1. Hold the blade end using a rag or thickly-padded glove. Remove the blade bolt, spring disk and blade from the spindle shaft (Fig. 34).

Sharpening the Blades

Warning

When sharpening blade, pieces of blade could be thrown and cause serious injury.

Wear proper eye protection when sharpening blade.

1. Use a file to sharpen the cutting edge at both ends of the blade (Fig. 32). Maintain the original angle. The blade retains its balance if the same amount of material is removed from both cutting edges.

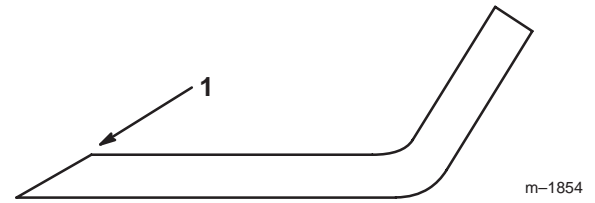

Figure 32

1. Sharpen at original angle

2. Check the balance of the blade by putting it on a blade balancer (Fig. 33). If the blade stays in a horizontal position, the blade is balanced and can be used. If the blade is not balanced, file some metal off the end of the sail area only (Fig. 34). Repeat this procedure until the blade is balanced.

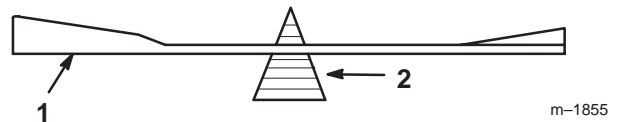

Figure 33

1. Blade
2. Balancer

Installing the Blades

1. Install the blade onto the spindle shaft (Fig. 34).

Important The curved part of the blade must be pointing upward toward the inside of the mower to ensure proper cutting.

2. Install the spring disk and blade bolt (Fig. 34). **Torque the blade bolt to 85–110 ft-lb (115–150 N•m).**

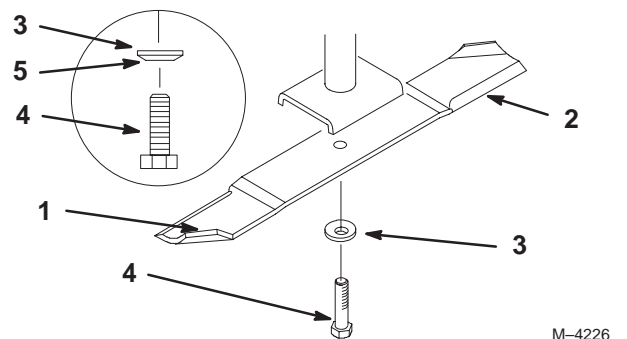

Figure 34

1. Sail Area of Blade
2. Blade
3. Spring Disk
4. Blade Bolt
5. Cone Towards Bolt Head

Servicing the Air Cleaner

Primary Filter: Check and/or replace after every 200 operating hours or more often in dusty conditions.

Safety Filter: Replace after every 600 operating hours.

Note: Check the filters more frequently if operating conditions are extremely dusty or sandy.

Removing the Filters

1. Disengage the power take off (PTO), set the parking brake, and turn the ignition key to off. Remove the key. Remove spark plug wire(s).
2. Release the latches on the air cleaner and pull the air cleaner cover off of the air cleaner body (Fig. 35).
3. Clean the inside of the air cleaner cover with compressed air.
4. Gently slide the primary filter out of the air cleaner body (Fig. 35). Avoid knocking the filter into the side of the body.
5. Remove the safety filter **only if you intend to replace it**.

Important Never attempt to clean the safety filter. If the safety filter is dirty, then the primary filter is damaged and you should replace both filters.

6. Inspect the primary filter for damage by looking into the filter while shining a bright light on the outside of the filter. Holes in the filter will appear as bright spots. If the filter is damaged discard it.

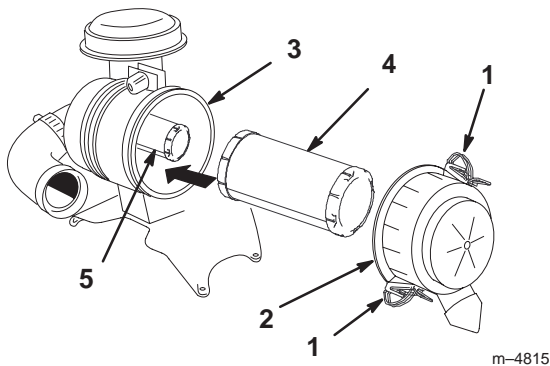

Figure 35

1. Latches
2. Air cleaner cover
3. Air filter body
4. Primary filter
5. Safety filter

Servicing the Primary Filter

Check and/or replace it after 200 operating hours.

If the primary filter is dirty, bent, or damaged then replace the filter.

Do not clean the primary filter.

Servicing the Safety Filter

Replace it after 600 operating hours.

Important Never attempt to clean the safety filter. If the safety filter is dirty, then the primary filter is damaged and you should replace both filters.

Installing the Filters

Important To prevent engine damage, always operate the engine with both air filters and cover installed.

1. If installing new filters, check each filter for shipping damage. Do not use a damaged filter.
2. If the safety filter is being replaced, carefully slide it into the filter body (Fig. 35).
3. Carefully slide the primary filter over the safety filter (Fig. 35). Ensure that it is fully seated by pushing on the outer rim of the filter while installing it.

Important Do not press on the soft inside area of the filter.

4. Install the air cleaner cover with the side indicated as **UP** facing up and secure the latches (Fig. 35).

Servicing the Engine Oil

Change oil:

- After the first 8 operating hours.
- After every 100 operating hours.

Note: Change oil more frequently when operating conditions are extremely dusty or sandy.

Oil Type: Detergent oil (API service SG or SH)

Crankcase Capacity: w/filter, 67 oz. (2.0 l)

Viscosity: See table below

USE THESE SAE VISCOSITY OILS

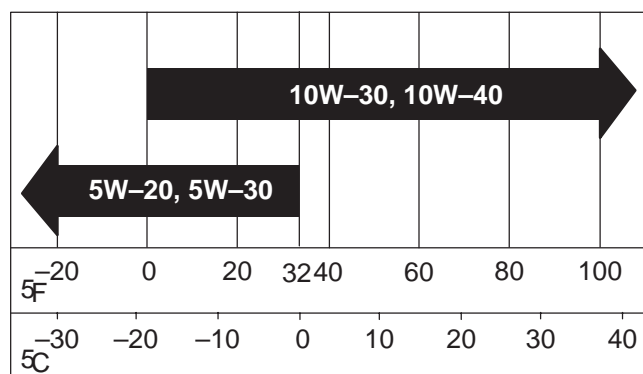

Checking the Oil Level

Note: Check oil when engine is cold.

1. Disengage the power take off (PTO) and turn the ignition key to off. Move levers to neutral locked position and apply parking brake. Remove the key.
2. Clean around the oil dipstick (Fig. 36) so dirt cannot fall into the filler hole and damage the engine.
3. Pull the oil dipstick and wipe the metal end clean (Fig. 36).
4. Slide the oil dipstick fully into the filler tube. Pull the dipstick out and look at the metal end (Fig. 36). If oil level is low, slowly pour only enough oil into the filler tube to raise the level to the the full mark.

Important Do not overfill the crankcase with oil because the engine may be damaged. Do not run engine with oil below the low mark because the engine may be damaged.

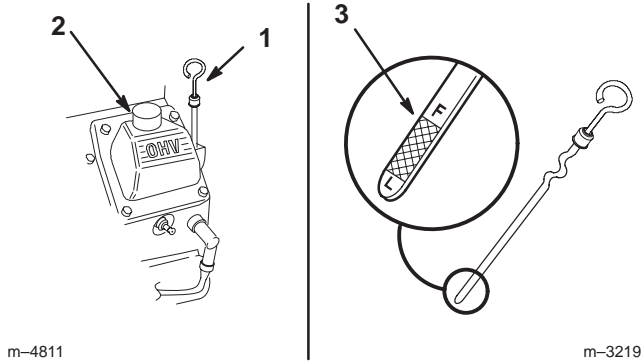

Figure 36

1. Oil dipstick
2. Filler tube
3. Metal end

Changing the Oil

1. Start the engine and let it run five minutes. This warms the oil so it drains better.
2. Park the machine so that the drain side is slightly lower than the opposite side to assure the oil drains completely. Disengage the power take off (PTO), set the parking brake, and turn the ignition key to off. Remove the key.
3. Place a pan below the oil drain. Use either a flat screw driver, 3/8 inch or 10 mm wrench to open valve (Fig. 37).
4. Rotate valve end clockwise to close valve. Rotate valve end counterclockwise to open valve (Fig. 37).

Note: Dispose of the used oil at a certified recycling center.

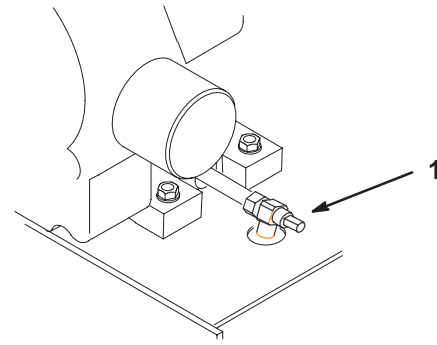

Figure 37

1. Oil drain valve
5. Slowly pour approximately 80% of the specified oil into the filler cap (Fig. 36). Refer to Servicing the Engine Oil, page 30.
6. Check the oil level; refer to Checking the Oil Level, page 31.
7. Slowly add additional oil to bring it to the full mark.

Changing the Oil Filter

Replace the oil filter every 200 hours or every other oil change.

Note: Change oil filter more frequently when operating conditions are extremely dusty or sandy.

1. Drain the oil from the engine; refer to Changing/Draining Oil, page 31.
2. Remove the old filter and wipe the filter adapter (Fig. 38) gasket surface.
3. Pour new oil of the proper type in through the center hole. Stop pouring when the oil reaches the bottom of the threads. Allow a minute or two for the oil to be absorbed by filter material.
4. Apply a thin coat of new oil to the rubber gasket on the replacement filter (Fig. 38).

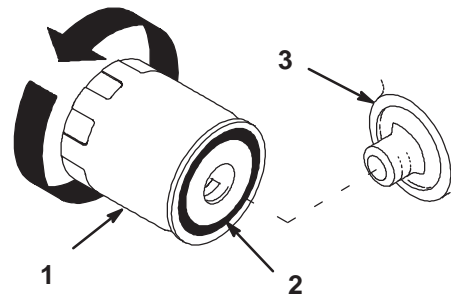

Figure 38

1. Oil filter
2. Gasket
3. Adapter

5. Install the replacement oil filter to the filter adapter. Turn the oil filter clockwise until the rubber gasket contacts the filter adapter, then tighten the filter an additional 1/2 turn (Fig. 38).
6. Fill the crankcase with the proper type of new oil; refer to Changing/Draining Oil, page 31.

Servicing the Spark Plug

Check the spark plug(s) after every 200 operating hours. Make sure the air gap between the center and side electrodes is correct before installing the spark plug. Use a spark plug wrench for removing and installing the spark plug(s) and a gapping tool/feeler gauge to check and adjust the air gap. Install a new spark plug(s) if necessary.

Type: Champion RC12YC (or equivalent)
Air Gap: 0.030 inch (0.76 mm)

Removing the Spark Plug(s)

1. Disengage the power take off (PTO) and turn the ignition key to off. Move levers to neutral locked position and apply parking brake. Remove the key.
2. Pull the wire(s) off the spark plug(s) (Fig. 39). Now clean around the spark plug(s) to prevent dirt from falling into the engine and potentially causing damage.
3. Remove the spark plug(s) and metal washer.

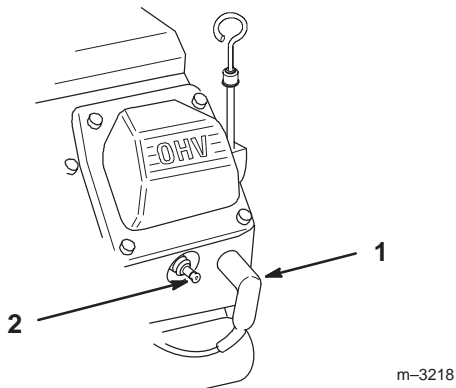

Figure 39

1. Spark plug wire
2. Spark plug

Checking the Spark Plug

1. Look at the center of the spark plug(s) (Fig. 40). If you see light brown or gray on the insulator, the engine is operating properly. A black coating on the insulator usually means the air cleaner is dirty.

Important Never clean the spark plug(s). Always replace the spark plug(s) when it has: a black coating, worn electrodes, an oily film, or cracks.

2. Check the gap between the center and side electrodes (Fig. 40). Bend the side electrode (Fig. 40) if the gap is not correct.

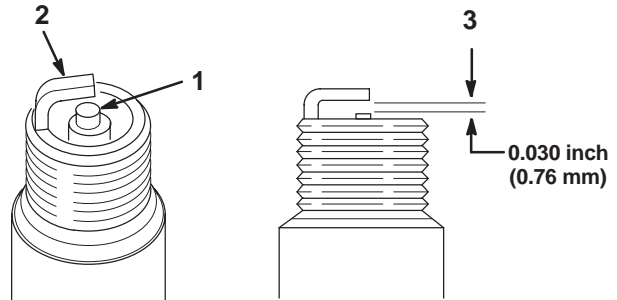

Figure 40

1. Center electrode insulator
2. Side electrode
3. Air gap (not to scale)

Installing the Spark Plug(s)

1. Install the spark plug(s). Make sure the air gap is set correctly.
2. Tighten the spark plug(s) to 20 ft-lb (27 N•m).
3. Push the wire(s) onto the spark plug(s) (Fig. 39).

Servicing the Fuel Filter

Replace the fuel filter after every 200 operating hours or yearly, whichever occurs first.

Replacing the Fuel Filter

Never install a dirty filter if it is removed from the fuel line.

1. Disengage the power take off (PTO) and turn the ignition key to off. Move levers to neutral locked position and apply parking brake. Remove the key.
2. Close fuel shut-off valve on console.
3. Squeeze the ends of the hose clamps together and slide them away from the filter (Fig. 41).

4. Remove the filter from the fuel lines.
5. Install a new filter and move the hose clamps close to the filter (Fig. 42).
6. Wipe up any spilled fuel.
7. Open fuel shut-off valve on console.

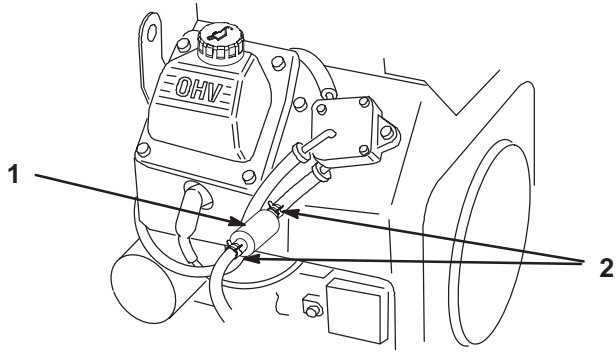

Figure 41

1. Filter
2. Hose clamp

Servicing the Fuel Tank

Draining The Fuel Tank

⚠
Danger
⚠

In certain conditions, gasoline is extremely flammable and highly explosive. A fire or explosion from gasoline can burn you and others and can damage property.

- **Drain gasoline from the fuel tank when the engine is cold. Do this outdoors in an open area. Wipe up any gasoline that spills.**
- **Never smoke when draining gasoline, and stay away from an open flame or where a spark may ignite the gasoline fumes.**

1. Park the machine on a level surface, to assure fuel tank drains completely. Then disengage the power take off (PTO), set the parking brake, and turn the ignition key to off. Remove the key.
2. Close fuel shut-off valve (Fig. 42).
3. Loosen the hose clamp at the fuel filter and slide it up the fuel line away from the fuel filter (Fig. 42).
4. Pull the fuel line off fuel filter (Fig. 42). Open fuel shut-off valve and allow gasoline to drain into a gas can or drain pan.

Note: Now is the best time to install a new fuel filter because the fuel tank is empty.

5. Install the fuel line onto the fuel filter. Slide the hose clamp close to the fuel filter to secure the fuel line (Fig. 42).

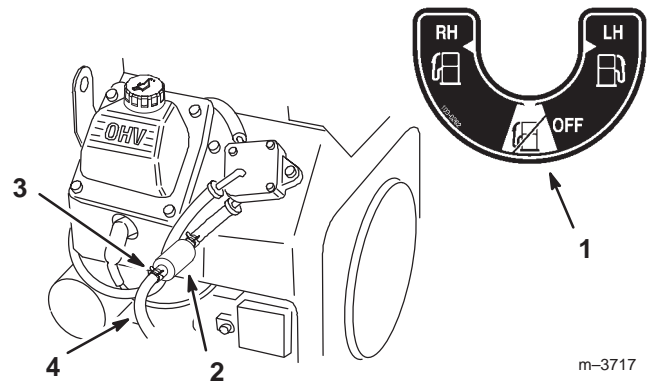

Figure 42

1. Fuel shut-off valve
2. Fuel filter
3. Hose clamp
4. Fuel line

Greasing and Lubrication

Lubricate the machine when shown on the **Check Service Reference Aid** decal (Fig. 43). Grease more frequently when operating conditions are extremely dusty or sandy.

Grease Type: General-purpose grease.

How to Grease

1. Disengage the power take off (PTO) and turn the ignition key to off. Move levers to neutral locked position and apply parking brake. Remove the key.
2. Clean the grease fittings with a rag. Make sure to scrape any paint off the front of the fitting(s).
3. Connect a grease gun to the fitting. Pump grease into the fittings until grease begins to ooze out of the bearings.
4. Wipe up any excess grease.

Greasing the Front Caster Pivots

Lubricate the front caster pivots once a year.

1. Remove the dust cap and adjust the caster pivots. Keep dust cap off until greasing is done.
2. Adjust the caster pivot bearing. Refer to Adjusting the Caster Pivot Bearing, page 35.
3. Remove the hex plug. Thread a grease zerk into hole.
4. Pump grease into zerk until it oozes out around top bearing.

- Remove grease zerk in hole. Reinstall hex plug and cap.

Where to Add Grease

Lubricate the grease fittings as shown on the **Check Service Reference Aid** decal (Fig. 43).

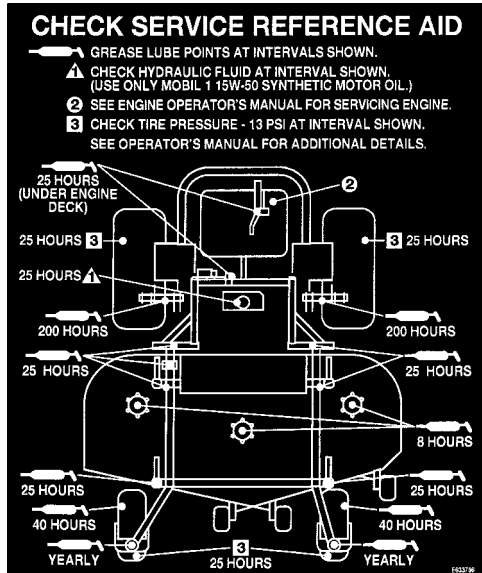

Figure 43

Where to Add Light Oil or Spray Lubrication

Lubricate the machine in the following areas with spray type lubricant or light oil. Lubricate every 160 hours.

- Seat switch actuator.
- Brake handle pivot.
- Brake rod bushings.
- Motion control bronze bushings.

Greasing the Bearings

The cutting unit must be lubricated daily. Refer to the Service Interval Chart on page 27. Grease with No. 2 general purpose lithium base or molybdenum base grease.

Important Make sure cutting unit spindles are full of grease daily.

- Stop the engine, set the parking brake, remove the key and disconnect the spark plug wire(s) from the spark plug(s).
- Grease the fittings on the three spindle bearings until grease comes out lower seals (Fig. 44).

- Grease the fittings on the push arms(Fig. 44).

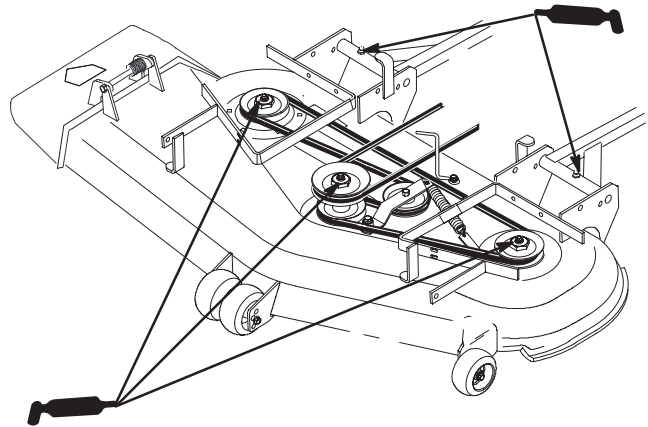

M-5035

Figure 44

Cleaning the Cooling Systems

Cleaning the Engine Screen and the Oil Cooler

Before each use, check and clean engine screen and oil cooler. Remove any build-up of grass, dirt or other debris from the oil cooler screen and engine air intake (Fig. 45).

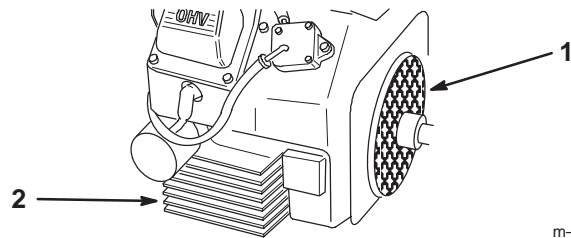

m-3801

Figure 45

- Engine screen
- Oil cooler

Cleaning the Engine Fins

Every 100 hours clean the engine cylinder and cylinder head cooling fins. Also clean around carburetor, governor levers and linkage. This will ensure adequate cooling of the engine and will reduce the possibility of overheating and mechanical damage.

- Remove the panels from the engine shroud.
- Clean the engine cooling fins.
- Install the panels onto the engine shroud.

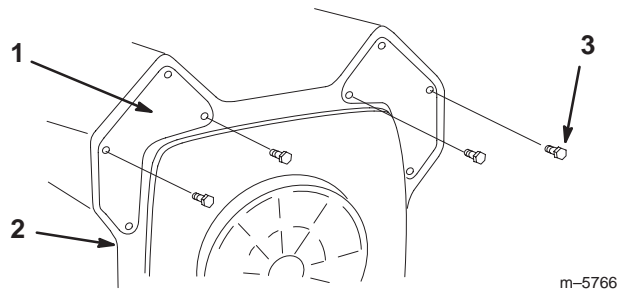

Figure 46

- 1. Panel
- 2. Engine shroud
- 3. Screws

Checking the Tire Pressure

Maintain the air pressure in the front and rear tires as specified. Uneven tire pressure can cause uneven cut. Check the pressure at the valve stem after every 50 operating hours or monthly, whichever occurs first (Fig. 47). Check the tires when they are cold to get the most accurate pressure reading.

Pressure: 13 psi (90 kPa) drive wheels and caster wheels.

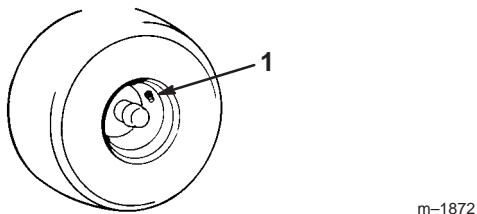

Figure 47

- 1. Valve stem

Checking the Wheel Hub Slotted Nut

Check after every 500 operating hours.

The slotted nut needs to be torqued to 125 ft-lb (170 N•m).

1. Stop the engine, set the parking brake, remove the key and disconnect the spark plug wire(s) from the spark plug(s).
2. Remove cotter pin.
3. Torque slotted nut to 125 ft-lb (170 N•m) (Fig. 48).
4. Check the distance from bottom of slot in nut to inside edge of hole. Two threads or less should be showing (Fig. 48).
5. If more than two threads are showing remove nut and install washer between hub and nut (Fig. 48).

6. Torque the slotted nut to 125 ft-lb (170 N•m) (Fig. 48).
7. Tighten nut until the next set of slots line up with the hole in the shaft (Fig. 48).
8. Replace cotter pin.

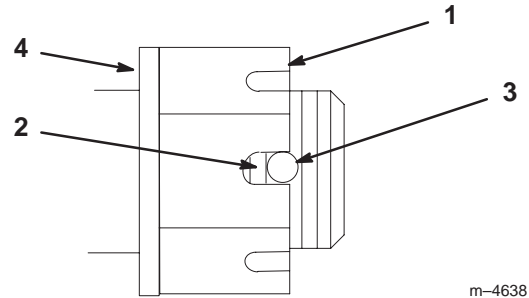

Figure 48

- 1. Slotted Nut
- 2. Two threads or less showing
- 3. Hole in threaded rod
- 4. Washer (if needed)

Adjusting the Caster Pivot Bearing

Check after every 500 operating hours or at storage, whichever comes first.

1. Stop the engine, set the parking brake, remove the key and disconnect the spark plug wire(s) from the spark plug(s).
2. Remove dust cap from caster and tighten lock nut (Fig. 49).
3. Tighten until spring washers are flat and then back off a 1/4 turn to properly set the pre-load on the bearings (Fig. 49).

Important Make sure spring washers are installed correctly as shown in figure 49.

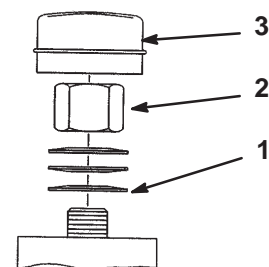

Figure 49

- 1. Spring Washers
- 2. Lock Nut
- 3. Dust Cap

Servicing the Hydraulic System

Checking the Hydraulic Fluid

Check the hydraulic fluid level before engine is first started.

Check the hydraulic fluid level after first 8 operating hours.

Check the hydraulic fluid level after every 25 operating hours.

Fluid Type: Mobil 1 15W-50 synthetic motor oil or equivalent synthetic oil.

Important Use oil specified or equivalent. Other fluids could cause system damage.

Hydraulic System Oil Capacity: 67 oz. (2.0 l)

Note: There are two ways of checking the hydraulic oil. One is when the oil is warm and one is when the oil is cold. The baffle inside the tank has two levels depending if the oil is warm or cold.

1. Position machine on a level surface and set the parking brake.
2. Clean area around filler neck of hydraulic tank (Fig. 50).
3. Remove cap from filler neck. Look inside to check if there is fluid in the reservoir. (Fig. 50).
4. If there is no fluid, add fluid to the reservoir until it reaches the *cold* level of the baffle.
5. Run the machine at low idle for 15 minutes to allow any air to purge out of the system and warm fluid. Refer to Starting and Stopping the Engine on page 19.
6. Recheck the fluid level while the fluid is warm. If required, add fluid to the reservoir until it reaches the *hot* level of the baffle.

Note: The fluid level should be to the top of the *hot* level of the baffle, when the fluid is warm (Fig. 50).

7. Install cap on filler neck.

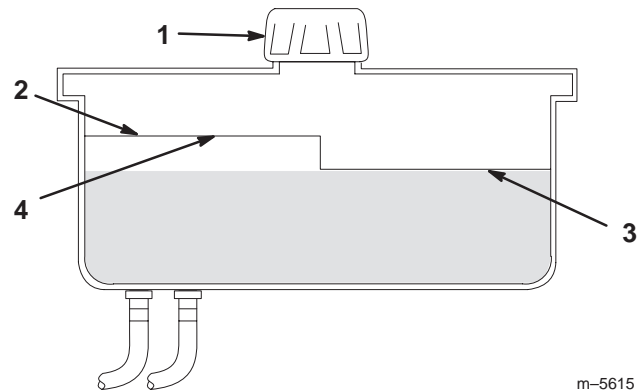

m-5615

Figure 50

1. Cap
2. Baffle
3. Cold fluid level—full
4. Hot fluid level—full

Warning

Hydraulic fluid escaping under pressure can penetrate skin and cause injury.

- If hydraulic fluid is injected into the skin it must be surgically removed within a few hours by a doctor familiar with this type of injury. Gangrene may result if this is not done.
- Keep body and hands away from pin hole leaks or nozzles that eject high pressure hydraulic fluid.
- Use cardboard or paper to find hydraulic leaks.
- Safely relieve all pressure in the hydraulic system before performing any work on the hydraulic system.
- Make sure all hydraulic fluid hoses and lines are in good condition and all hydraulic connections and fittings are tight before applying pressure to hydraulic system.

Replacing the Hydraulic Filter

Change the hydraulic filter:

- After the first 8 operating hours.
 - After every 200 operating hours.
1. Disengage the power take off (PTO) and turn the ignition key to off. Move levers to neutral locked position and apply parking brake. Remove the key.

Important Do not substitute automotive oil filter or severe hydraulic system damage may result.

2. Remove hydro cap and temporarily cover opening with a plastic bag and rubber band to prevent all hydro fluid from draining out.
3. Place drain pan under filter, remove the old filter and wipe the filter adapter gasket surface clean (Fig. 51).

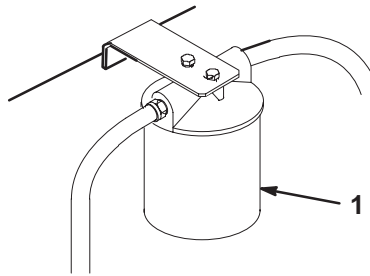

M-4763

Figure 51

1. Hydraulic filter

4. Apply a thin coat hydro fluid to the rubber gasket on the replacement filter (Fig. 52).
5. Install replacement hydraulic filter onto the filter adapter. Do not tighten.
6. Remove plastic bag from tank opening and allow filter to fill with hydro fluid.
7. When fluid overflows filter turn the oil filter clockwise until the rubber gasket contacts the filter adapter, then tighten the filter an additional 1/2 turn (Fig. 52).
8. Clean up any spilled fluid.
9. If there is no fluid, add fluid to reservoir approximately a 1/4 inch (6mm) below the top of baffle.
10. Start engine and let run for about two minutes to purge air from the system. Stop the engine and check for leaks. If one or both wheels will not drive, refer Bleeding the Hydraulic System, page 37.
11. Recheck level while fluid is warm. Add fluid to raise level to top of the baffle, if required. **Do not overfill.**

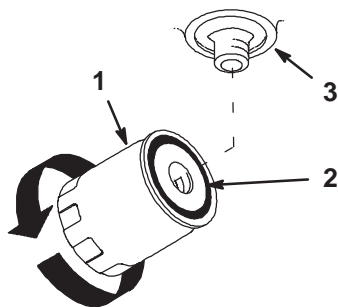

m-1256

Figure 52

1. Hydraulic filter
2. Gasket
3. Adapter

Bleeding the Hydraulic System

The traction system is self bleeding, however, it may be necessary to bleed the system if fluid is changed or after work is performed on the system.

1. Raise rear of the machine so wheels are off the ground and support with jack stands.
2. Start the engine and run at idle speed. Engage traction on one side and spin the wheel by hand.
3. When the wheel begins to spin on its own, keep it engaged until wheel drives smoothly. (minimum 2 minute)
4. Check hydraulic fluid level as it drops and add as required to maintain proper level.
5. Repeat procedure on opposite wheel.

Checking the Hydraulic Lines

After every 100 operating hours, check hydraulic lines and hoses for leaks, loose fittings, kinked lines, loose mounting supports, wear, weather and chemical deterioration. Make necessary repairs before operating.

Note: Keep areas around hydraulic system clean from grass and debris build up.



Warning



Hydraulic fluid escaping under pressure can penetrate skin and cause injury.

- If hydraulic fluid is injected into the skin it must be surgically removed within a few hours by a doctor familiar with this type of injury. Gangrene may result if this is not done.
- Keep body and hands away from pin hole leaks or nozzles that eject high pressure hydraulic fluid.
- Use cardboard or paper to find hydraulic leaks.
- Safely relieve all pressure in the hydraulic system before performing any work on the hydraulic system.
- Make sure all hydraulic fluid hoses and lines are in good condition and all hydraulic connections and fittings are tight before applying pressure to hydraulic system.

Adjusting the Handle Neutral

If motion control levers do not align, or move easily into the console notch, adjustment is required. Adjust each lever, spring and rod separately.

Note: Motion control levers must be installed correctly. See Installing the Motion Control Levers, page 15.

1. Stop the engine, remove ignition key and tilt seat forward.
2. Begin with either the left or right motion control lever.
3. Move lever to the neutral position but **not locked** (Fig. 54).
4. Pull lever back until the clevis pin (on arm below pivot shaft) contacts the end of the slot (just beginning to put pressure on the spring) (Fig. 54).
5. Check where the control lever is relative to notch in console (Fig. 53). It should be centered allowing lever to pivot outward to the neutral lock position.

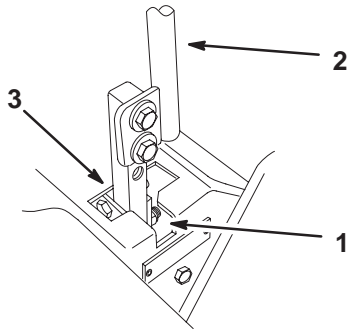

Figure 53

1. Neutral locked position
2. Control lever
3. Neutral position

m-6282

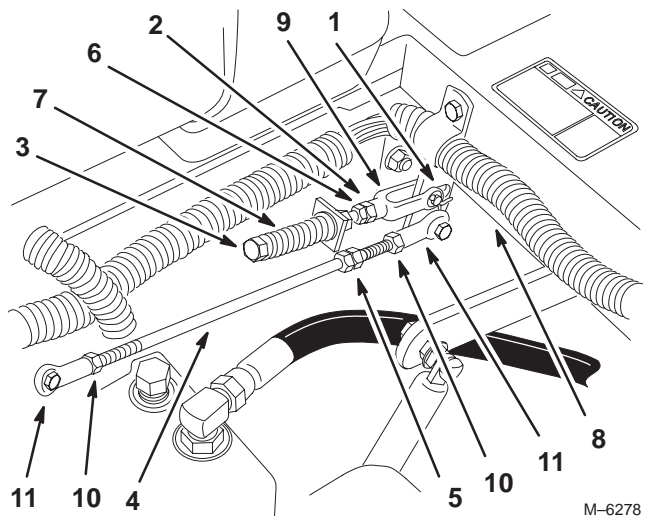

Figure 54

- | | |
|-----------------------|----------------|
| 1. Clevis pin in slot | 7. Spring |
| 2. Nut against yoke | 8. Pivot shaft |
| 3. Adjustment bolt | 9. Yoke |
| 4. Pump rod | 10. Locknut |
| 5. Double nuts | 11. Ball joint |
| 6. Jam Nut | |

M-6278

Setting the Hydraulic Pump Neutral

Note: Adjust handle neutral first. That has to be correct before the following adjustment can be made.

Danger

Mechanical or hydraulic jacks may fail to support machine and cause a serious injury.

- Use jack stand when supporting machine.
- Do not use hydraulic jacks.

Warning

Engine must be running so motion control adjustment can be performed. Contact with moving parts or hot surfaces may cause personal injury.

Keep hands, feet, face, clothing and other body parts away from rotating parts, muffler and other hot surfaces.

This adjustment must be made with drive wheels turning.

1. Raise the frame and block up the machine so drive wheels can rotate freely.
2. Disconnect electrical connector from the seat safety switch. **Temporarily** install a jumper wire across terminals in the wiring harness connector.
3. Slide seat forward, disconnect prop rod and tilt seat fully forward.

Setting the Right-hand Hydraulic Pump Neutral

1. Start the engine, open throttle 1/2 way and release parking brake. Refer to Starting and Stopping the Engine, page 19.

Note: Motion control lever must be in neutral while making any adjustments.

2. Adjust pump rod length by rotating the knob, in the appropriate direction, until the wheel is still or slightly creeping in reverse (Fig. 55).
3. Move motion control lever forward and reverse, then back to neutral. Wheel must stop turning or slightly creep in reverse.
4. Open throttle to fast. Make sure wheel remains stopped or slightly creeps in reverse, adjust if necessary.

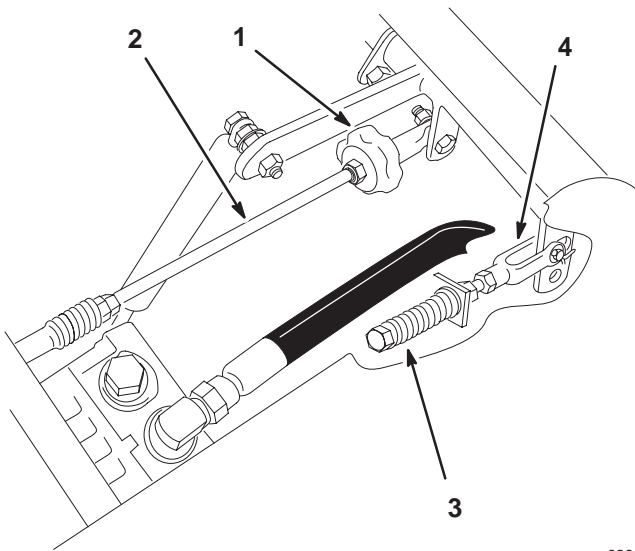

m-6281

Figure 55

- | | |
|------------------|--------------------|
| 1. Tracking knob | 3. Adjustment bolt |
| 2. Pump rod | 4. Yoke |

Setting the Left-hand Hydraulic Pump Neutral

1. Loosen the locknuts at the ball joints on pump control rod (Fig. 54).
2. Start the engine, open throttle 1/2 way and release parking brake. Refer to Starting and Stopping the Engine, page 19.

Note: Motion control lever must be in neutral while making any adjustments.

Note: The front nut on the pump rod has left-hand threads.

3. Adjust pump rod length by rotating double nuts on rod, in the appropriate direction, until wheel is still or slightly creeps in reverse (Fig. 54).
4. Move motion control lever forward and reverse, then back to neutral. Wheel must stop turning or slightly creep in reverse.
5. Open throttle to fast. Make sure wheel remains stopped or slightly creeps in reverse, re-adjust if necessary.
6. Tighten the locknuts at the ball joints (Fig. 54).

⚠

Warning

⚠

Electrical system will not perform proper safety shut off with jumper wire installed.

- Remove jumper wire from wire harness connector and plug connector into seat switch when adjustment is completed.
- Never operate this unit with jumper installed and seat switch bypassed.

7. After both pump neutrals are set, shut off the machine.
8. Remove jumper wire from wire harness connector and plug connector into seat switch.
9. Reinstall prop rod and lower the seat into position.

Adjusting the Tracking

The right hand pump has a knob for adjusting the tracking.

Important Adjust the handle neutral and hydraulic pump neutral before adjusting the tracking. Refer to Adjusting the Handle Neutral on page 37 and Adjusting the Hydraulic Pump Neutral on page 38.

1. Push both control levers forward the same distance.
2. Check if the machine pulls to one side. If it does, stop the machine and set the parking brake.

3. Tip the seat up to access the tracking knob.

Note: Determine the left and right sides of the machine from the normal operating position.

4. To make the machine go right, turn the knob towards the rightside of the machine. Refer to figure 56.
5. To make the machine go left, turn the knob towards the leftside of the machine. Refer to figure 56.
6. Repeat adjustment until the tracking is correct.

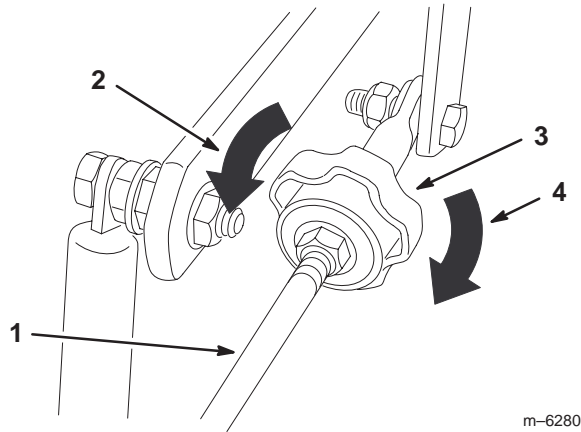

Figure 56

- | | |
|--------------------------------|---------------------------------|
| 1. Pump rod | 3. Tracking knob |
| 2. Turn this way to track left | 4. Turn this way to track right |

Replacing the Pump Drive Belt

Check pump drive belt for wear after every 50 hours of operation.

1. Pull spring loaded idler down and remove traction belt from the engine and hydro pump pulleys (Fig. 57). Remove belt between pulleys.
2. Install new belt around engine and hydro pump pulleys (Fig. 57).
3. Pull spring loaded idler down and align below traction belt. Release pressure on spring loaded idler (Fig. 57).

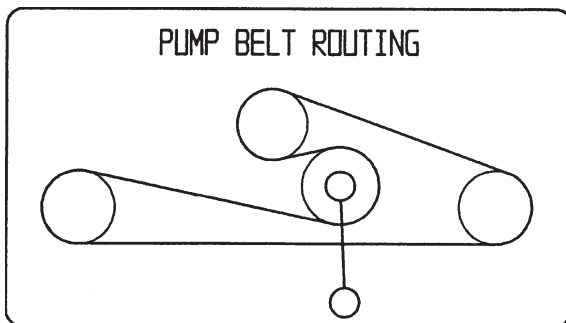

Figure 57

Adjusting the Parking Brake

Check parking brake for proper adjustment.

1. Disengage brake lever (lever down).
2. Measure the length of the spring. Measurement should be 2-3/4 inch (70 mm) between washers (Fig. 58).
3. If adjustment is necessary, loosen the jam nut below the spring and tighten the nut directly below the yoke (Fig. 58). Turn the nut until the correct measurement is obtained. Tighten the two nuts together and repeat on opposite side of unit.
4. Turn nuts clockwise to shorten spring length and turn counter-clockwise to lengthen the spring.
5. Engage parking brake, lever up.
6. Measure the distance between the trunnion roller and the collar on brake rod. Measurement should be 3/16-1/4 inch (5-7 mm) (Fig. 58).
7. If adjustment is necessary, loosen the jam nut directly below the yoke. Turn the bottom rod until the correct measurement is obtained (Fig. 58). Tighten jam nut at yoke

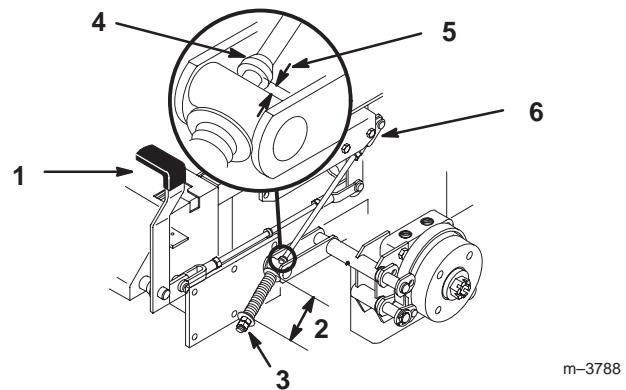

Figure 58

- | | |
|------------------------------|---------------------------|
| 1. Brake lever | 4. Collar on brake rod |
| 2. Spring, 2.75 inch (70 mm) | 5. 3/16-1/4 inch (5-7 mm) |
| 3. Adjusting nuts | 6. Jam nut and yoke |

Servicing the Fuse

Service Interval/Specification

The electrical system is protected by fuses. It requires no maintenance, however, if a fuse blows check component/circuit for malfunction or short.

Fuse: Main F1-20 amp, blade-type
Alternator F2-20 amp, blade-type

1. Raise the seat to gain access to fuse holder (Fig. 59).

- To replace fuses pull out on the fuse to remove it (Fig. 59).

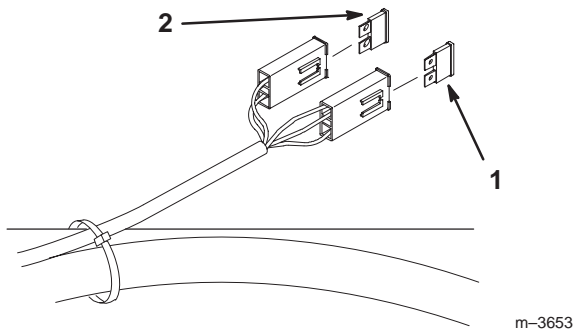

Figure 59

- Main-20 amp
- Alternator-20 amp

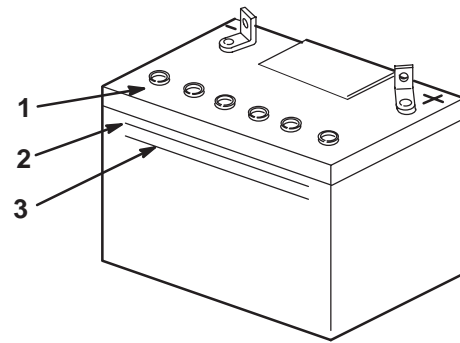

Figure 60

- Filler caps
- Upper line
- Lower line

Servicing the Battery

⚠
Warning
⚠

Battery posts, terminals, and related accessories contain lead and lead compounds, chemicals known to the State of California to cause cancer and reproductive harm. *Wash hands after handling.*

Checking the Electrolyte Level

- With the engine off, locate the battery under the seat.
- Look at the side of the battery. The electrolyte must be up to the **upper** line (Fig. 60). Do not allow the electrolyte to get below the **lower** line (Fig. 60).
- If the electrolyte is low, add the required amount of distilled water; refer to Adding Water to the Battery, page 42.

⚠
Danger
⚠

Battery electrolyte contains sulfuric acid which is a deadly poison and causes severe burns.

- Do not drink electrolyte and avoid contact with skin, eyes or clothing. Wear safety glasses to shield your eyes and rubber gloves to protect your hands.
- Fill the battery where clean water is always available for flushing the skin.
- Follow all instructions and comply with all safety messages on the electrolyte container.

Installing the Battery

- Position battery in tray with terminal posts toward the engine (Fig. 61).
- First, install the positive (red) battery cable to positive (+) battery terminal.
- Then install negative battery cable and ground wire to the negative (-) battery terminal.
- Secure cables with 2 bolts (1/4 x 3/4 inch), 2 washers (1/4 inch), and 2 locknuts (1/4 inch) (Fig. 61).
- Slide the red terminal boot onto the positive (red) battery post.

- Secure battery with J-bolts, hold down clamp and 2 washers (1/4 inch), and 2 wing nuts (1/4 inch) (Fig. 61).

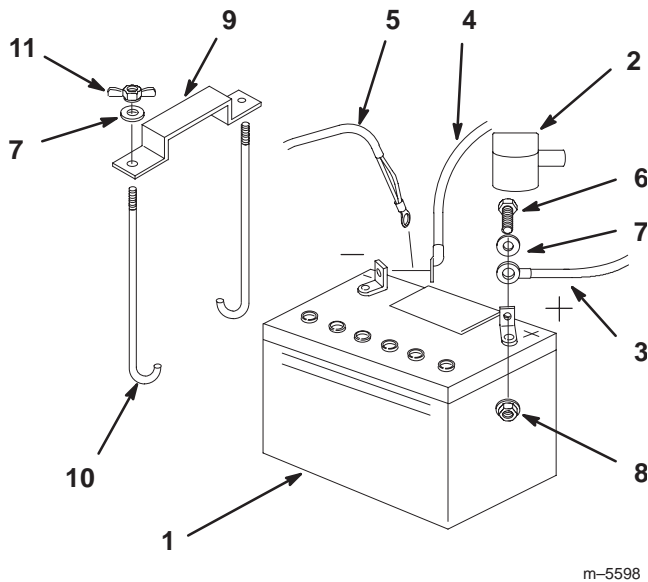

Figure 61

- | | |
|---------------------------|------------------------|
| 1. Battery | 7. Washer, 1/4 inch |
| 2. Terminal boot | 8. Locknut, 1/4 inch |
| 3. Positive battery cable | 9. Battery clamp |
| 4. Negative battery cable | 10. J-bolts |
| 5. Ground wire | 11. Wing nut, 1/4 inch |
| 6. Bolt, 1/4 x 3/4 inch | |

Removing the Battery



Warning



Battery terminals or metal tools could short against metal machine components causing sparks. Sparks can cause the battery gasses to explode, resulting in personal injury.

- When removing or installing the battery, do not allow the battery terminals to touch any metal parts of the machine.
- Do not allow metal tools to short between the battery terminals and metal parts of the machine.



Warning



Incorrect battery cable routing could damage the machine and cables causing sparks. Sparks can cause the battery gasses to explode, resulting in personal injury.

- Always *Disconnect* the negative (black) battery cable before disconnecting the positive (red) cable.
- Always *Reconnect* the positive (red) battery cable before reconnecting the negative (black) cable.

- Disengage the power take off (PTO), set the parking brake, and turn the ignition key to off. Remove the key.
- Tilt seat up.
- First disconnect the negative battery cable and ground wire from the negative (-) battery terminal (Fig. 61).
- Slide the red terminal boot off the positive (red) battery terminal. Then remove positive (red) battery cable (Fig. 61).
- Remove both wing nuts (1/4 inch) securing the battery clamp (Fig. 61).
- Remove the battery.

Adding Water to the Battery

The best time to add distilled water to the battery is just before you operate the machine. This lets the water mix thoroughly with the electrolyte solution.

- Remove the battery from the machine.
- Clean the top of the battery with a paper towel.

Note: Never fill the battery with distilled water while the battery installed in the machine. Electrolyte could be spilled on other parts and cause corrosion.

- Remove the vent caps from the battery (Fig. 60).
- Slowly pour distilled water into each battery cell until the level is up to the **upper** line (Fig. 60) on the battery case.

Important

Do not overfill the battery because electrolyte (sulfuric acid) can cause severe corrosion and damage to the chassis.

- Wait five to ten minutes after filling the battery cells. Add distilled water, if necessary, until the electrolyte level is up to the **upper** line (Fig. 60) on the battery case.
- Reinstall battery vent caps.

Charging the Battery

⚠
Warning
⚠

Charging the battery produces gasses that can explode.

Never smoke near the battery and keep sparks and flames away from battery.

Important Always keep the battery fully charged (1.265 specific gravity). This is especially important to prevent battery damage when the temperature is below 32°F (0°C).

- Remove the battery from the chassis; refer to Removing the Battery, page 42.
- Check the electrolyte level; refer to Checking Electrolyte Level, page 41.
- Make sure the filler caps are installed in battery. Charge battery for 10 to 15 minutes at 25 to 30 amps or 30 minutes at 4–6 amps.
- When the battery is fully charged, unplug the charger from the electrical outlet, then disconnect the charger leads from the battery posts (Fig. 62).

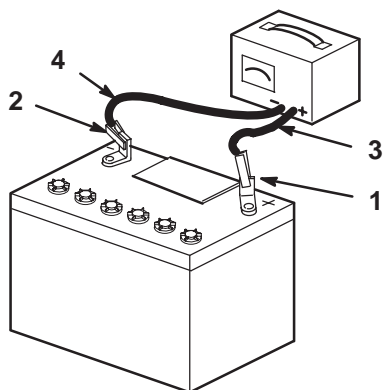

Figure 62

- | | |
|--------------------------|---------------------------|
| 1. Positive Battery Post | 3. Red (+) Charger Lead |
| 2. Negative Battery Post | 4. Black (-) Charger Lead |

- Install the battery in the machine and connect the battery cables; refer to Installing the Battery on page 41.

Note: Do not run the machine with the battery disconnected, electrical damage may occur.

Leveling the Mower

- Position mower on a flat surface. Stop the engine, set the parking brake, remove the key and disconnect the spark plug wire(s) from the spark plug(s).
- Check tire pressure of all four tires. If needed, adjust to 13 psi (90 kPa)
- Set anti-scalp rollers to top holes or remove them completely for this adjustment.
- Raise the deck to the transport position and take all force off of the two large deck lift springs by loosening nut in front of each spring (Fig. 63).
- Place two 1-1/2 inch (38 mm) thick blocks under rear left and right lower edge of mower. Place one 2-1/4 inch (57 mm) block under front center lower edge of mower. Lower mower to the 2 inch (51 mm) height-of-cut position (Fig. 63).

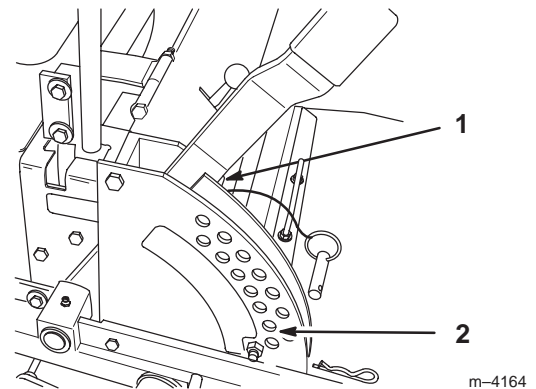

Figure 63

- | | |
|-----------------------|---------------------------------|
| 1. Transport position | 2. 2 inch (51 mm) height-of-cut |
|-----------------------|---------------------------------|
- Loosen four (4) top chain bolts in slots. Check the length of the rod/swivel assemblies. Distance from outside of rear swivel to outside of front swivel should be 19–17/32 inch (496 mm) (Fig. 64). Make sure that all four swivels move freely in holes.
 - If measurement is not 19–17/32 inch (496 mm) on each side, adjust by turning nuts on either side of front swivels.
 - Lift up on 4 top chain attachment bolts, in the slots, to take slack out of chains and tighten flange lock nuts. (Deck is still supported by two rear and one front blocks under mower.)
 - If bolts contact the end of slots, shorten or lengthen rod/swivel assemblies as required, for extra clearance, adjust each side same amount.

Note: When properly adjusted, the front blade tip will be slightly lower than the rear blade tip. See Checking for Bent Blades on page 28 to measure.

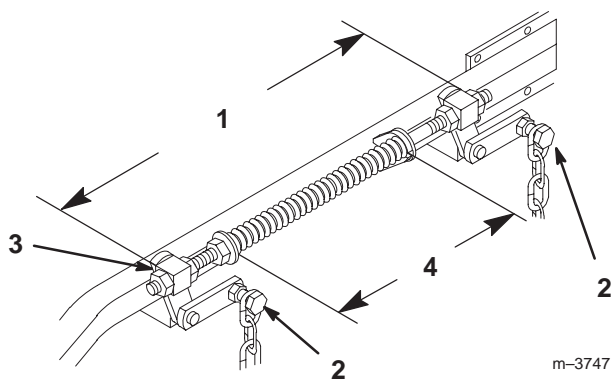

Figure 64

- | | |
|--|--|
| 1. 19–17/32 inch (496 mm)
outside swivels | 3. Front swivel |
| 2. Top chain bolt | 4. 10–1/4 inch (260 mm)
spring compressed |

10. Recheck that blocks just fit just under the mower and that tension on all four chains is approximately equal. Tighten chain attachment bolts securely.
11. Measure height of cut. This can be checked with the same procedure as Checking for Bent Blades on page 28.
12. Install anti-scalp rollers for proper height-of-cut and tighten securely.

Compression Spring Adjustment

1. Raise deck lift lever to the transport position, (Fig. 63).
2. Springs are compressed so the distance between the two large washers should be 10–1/4 inch (260 mm) (Fig. 64).
3. Adjust by turning nut in front of each spring (Fig. 64). Clockwise will shorten spring; counter-clockwise will lengthen spring.

Cleaning Under the Deck

Remove grass buildup under the deck daily.

1. Position the mower on a flat surface. Stop the engine, set the parking brake, remove the key, and disconnect the spark plug wire(s) from the spark plug(s).
2. Raise the deck to the transport position.
3. Raise the front of the machine by using the Z Stand; refer to Using the Z Stand, page 25.



Warning



Unit could fall onto someone and cause serious injury or death.

- Use extreme caution when operating unit on Z Stand.
- Use only for cleaning deck and removing blades.
- Do not keep unit on Z Stand for extended periods of time.
- Always shut engine off and set parking brake before performing any maintenance to deck.

Inspecting the Belts

Inspect all belts every 100 hours.

1. Check belts for cracks, frayed edges, burn marks or any other damage. Replace damaged belts.

Replacing the Deck Belt

Squealing when the belt is rotating, blades slipping when cutting grass, frayed belt edges, burn marks and cracks are signs of a worn deck belt. Replace the deck belt if any of these conditions are evident.

1. Stop the engine, set the parking brake, remove the key and disconnect the spark plug wire(s) from the spark plug(s).
2. Remove the PTO drive belt. Refer to Replacing the PTO Drive Belt, on page 45.
3. Loosen both nuts securing idler plate and move the idler arm to relieve belt tension on the idler pulley, then remove the worn deck belt (Fig. 65).
4. Install the new deck belt around the spindle pulleys, belt guide, the idler pulley, and in the lower groove of the center spindle pulley (Fig. 65).
5. Using a socket and torque wrench, rotate the idler adjusting nut until torque is 25–30 ft.-lb (34–41 N•m). Tighten both nuts.

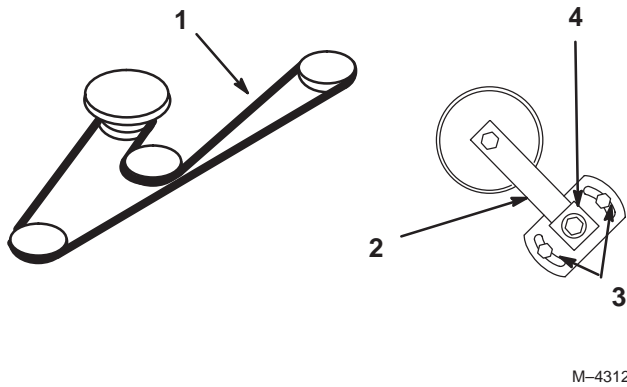

Figure 65
Top View

- | | |
|--------------|------------------------|
| 1. Deck Belt | 3. Idler nuts |
| 2. Idler Arm | 4. Idler adjusting nut |

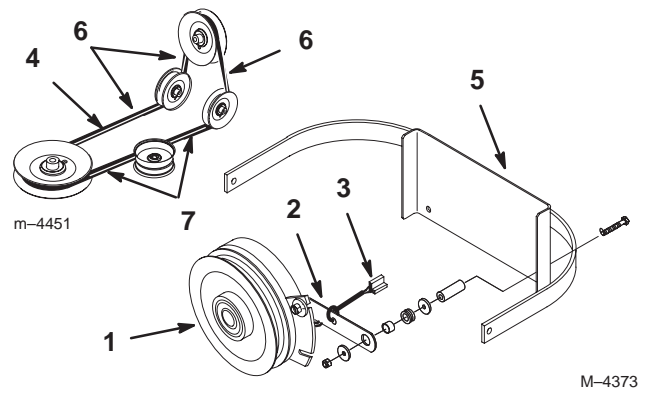

Figure 66

- | | |
|---------------------------|------------------------|
| 1. Clutch | 5. Machine Frame |
| 2. Clutch retaining strap | 6. 1/4" Belt Twist |
| 3. clutch Terminal | 7. 1/8 inch Belt Twist |
| 4. PTO belt | |

6. Reinstall the PTO drive belt. Refer to Replacing the PTO Drive Belt, page 45.

Replacing the PTO Drive Belt

Squealing when the belt is rotating, blades slipping when cutting grass, frayed belt edges, burn marks and cracks are signs of a worn drive belt. Replace the PTO drive belt if any of these conditions are evident.

1. Stop the engine, set the parking brake, remove the key and disconnect the spark plug wire(s) from the spark plug(s).
2. Remove the clutch retaining strap from machine frame and unplug clutch terminal from wire harness (Fig. 66).
3. Remove PTO drive belt from rear idler arm and front idler pulley assembly. Remove the PTO drive belt (Fig. 66).
4. Place new drive belt over clutch, around rear idler pulley, installed into rear idler arm assembly, installed into front idler pulley assembly and onto top center pulley (Fig. 66).

Important Check the amount of twist in belt between pulleys. Make sure it is only what is specified in figure 66.

5. Install clutch retaining strap and plug clutch terminal into main wire harness (Fig. 66).

6. Check belt tension. The center bolt of spring loaded idler must be between the two alignment holes in left support plate (Fig 67).

Note: Check position of center bolt in Low Height of Cut. The center bolt must be at or below the top alignment hole.

Check position of center bolt in a High Height of Cut. The center bolt must be at or above the lower adjustment hole (Fig 67).

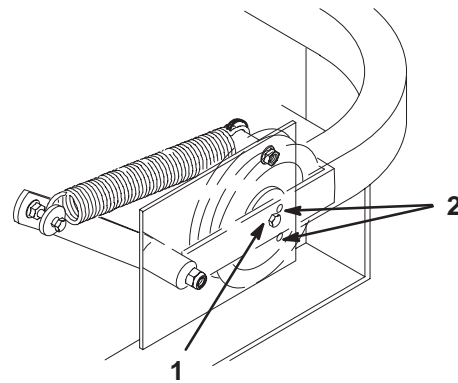

Figure 67

- | | |
|-------------------------------------|-------------------|
| 1. Center bolt, spring loaded idler | 2. Alignment hole |
|-------------------------------------|-------------------|

- If adjustment is required, loosen the fixed idler on right support plate and move up or down in adjustment slot. To relieve belt tension lift up on spring loaded idler.

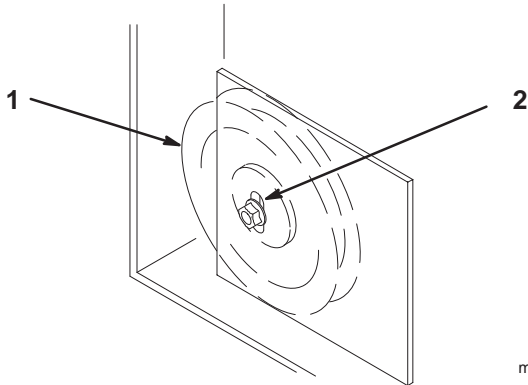

Figure 68

- Fixed Idler
- Adjustment slot

- Check belt tension again. The center bolt of spring loaded idler must be between the two alignment holes in left support plate (Fig 67). Adjust, if necessary, and tighten all hardware securely.
- If the fixed idler contacts the end of the adjustment slot and more belt tension is required, a small change to lengthen the push arms can be made (Fig. 69).
- To lengthen, loosen jam nut and rotate ball joint counterclockwise, one turn at a time. Adjust each side the same amount.

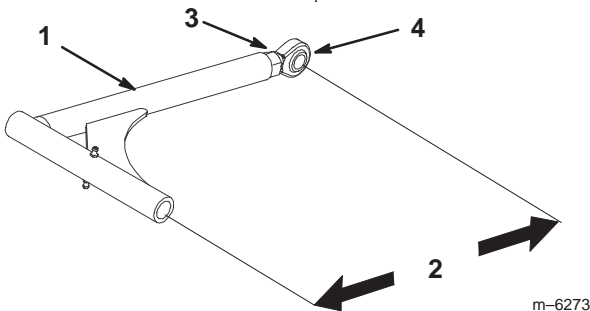

Figure 69

- Push arm
- 15–5/16 inch (389 mm) nominal
- Jam nut
- Ball joint

- Rotate the belt guide, on rear of the mower, so it is 1/8–1/4 inch (3–7 mm) away from the vertical side of the PTO belt (Fig. 70).

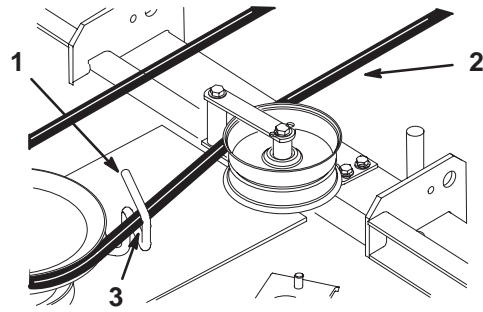

Figure 70

- Belt guide
- PTO Drive belt
- 1/8–1/4 inch (3–7 mm)

Replacing the Grass Deflector



Warning



An uncovered discharge opening could allow the lawn mower to throw objects in the operator's or bystander's direction and result in serious injury. Also, contact with the blade could occur.

Never operate the lawn mower unless you install a cover plate, a mulch plate, or a grass chute and catcher.

- Remove the locknut, bolt, spring and spacer holding the deflector to the pivot brackets (Fig. 71). Remove damaged or worn grass deflector.
- Place spacer and spring onto grass deflector. Place the L end of spring behind deck edge.

Note: Make sure the L end of spring is installed behind deck edge before installing the bolt as shown in figure 71.

- Install bolt and nut. Place J hook end of spring around grass deflector (Fig. 71).

Important The grass deflector must be able to lower down into position. Lift the deflector up to test that it lowers into the full down position.

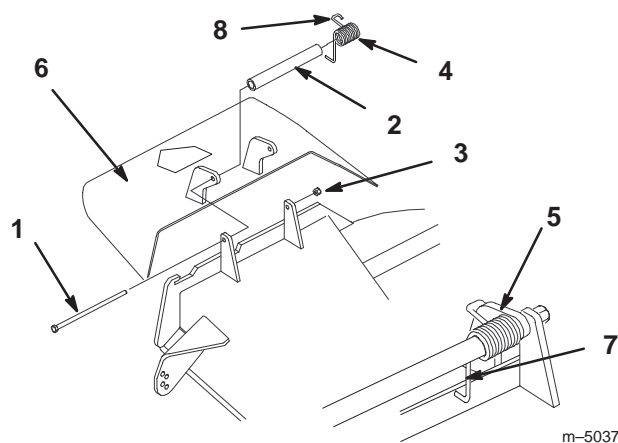

Figure 71

- | | |
|---------------------|---|
| 1. Bolt | 6. Grass Deflector |
| 2. Spacer | 7. L end of spring, place behind deck edge before installing bolt |
| 3. Locknut | 8. J hook end of spring |
| 4. Spring | |
| 5. Spring installed | |

Waste Disposal

Engine oil, hydraulic oil and engine coolant are pollutants to the environment. Dispose of these according to your state and local regulations.

Mercury Tilt Switch

The tilt switch on this unit contains mercury, a hazardous material. Mercury that is outside a sealed container vaporizes at room temperature. The vapors are harmful. Mercury can be absorbed through the skin. Do not attempt to open or repair this switch.

A very small amount of mercury is contained in a hermetically sealed body. The steel switch is then potted in a hard epoxy in a plastic case. It is unlikely that the mercury will ever escape from the enclosure. These high performance and reliable inexpensive switches are recyclable.

Mercury is an important and beneficial compound but requires special care in handling and disposal. When used and managed properly, mercury is not a threat to people or the environment. This information is presented to users so that they are aware that these switches contain mercury and will apply sound disposal practices when these devices reach their normal end of life or are damaged.

Disposing the Mercury Tilt Switch

Several states have passed laws concerning the disposal of devices containing mercury. In all the remaining states it is advisable to follow similar procedures. The laws state

that these sealed devices contain mercury and should not be placed in the garbage until the mercury is removed and reused, recycled or otherwise managed to insure that it does not become part of solid waste or waters.

Management and disposal practices must be within relevant federal, state or local laws.

Return the switch to your Toro dealer if it is faulty and is being replaced or if the unit containing the switch is no longer operating and is being scrapped. If the switch is damaged or broken open use extreme caution in handling. Call your local waste management authority or Toro Customer Service for instructions.

⚠
Caution
⚠

The mercury contained in the tilt switch is poisonous and exposure to mercury can cause severe illness.

- **Never attempt to open or repair the tilt switch.**
- **Avoid contact with the mercury.**

Wiring Diagram

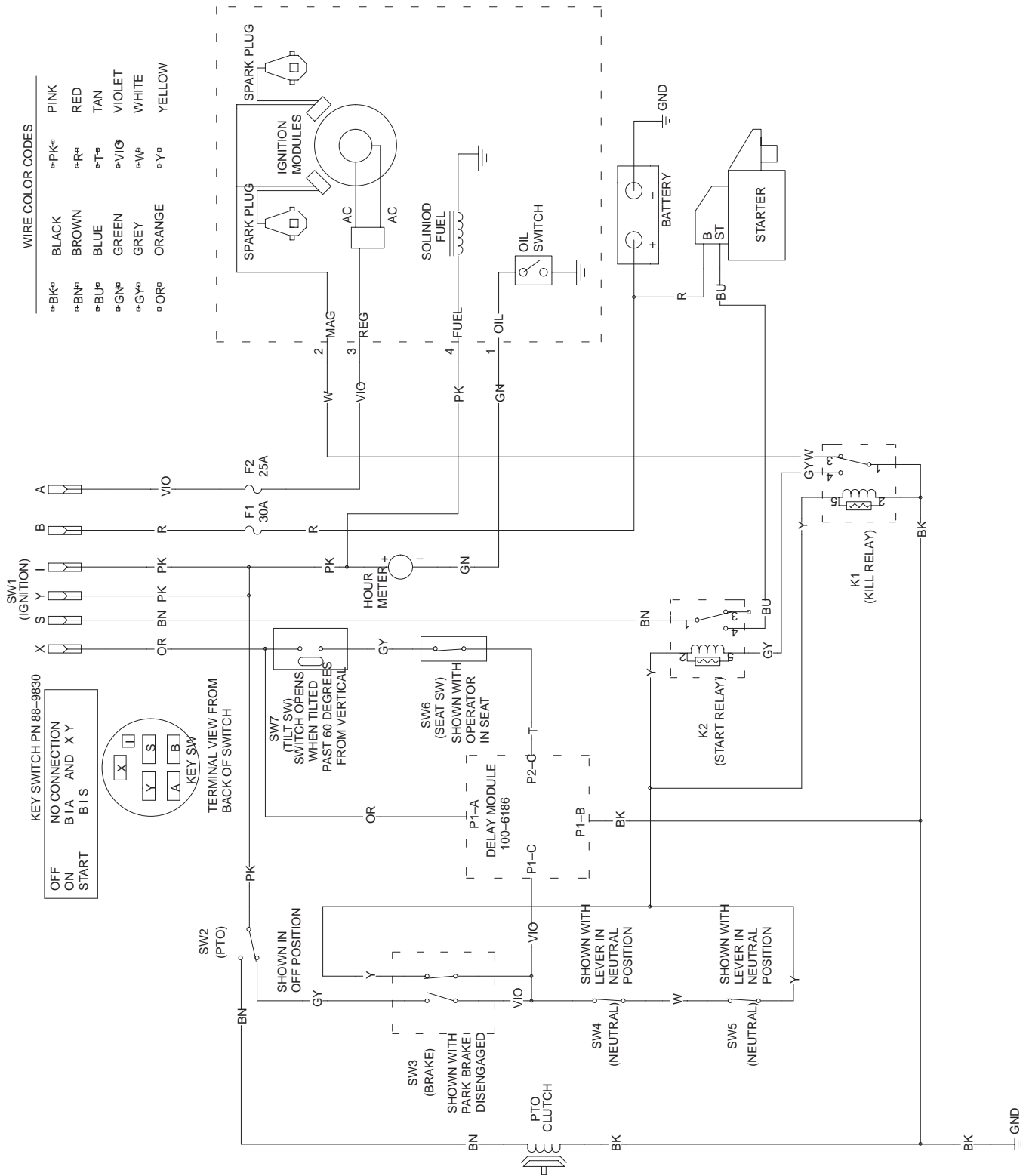

Cleaning and Storage

1. Disengage the power take off (PTO), set the parking brake and turn the ignition key to off. Remove spark plug wire. Remove the key.
2. Remove grass clippings, dirt, and grime from the external parts of the entire machine, especially the engine and hydraulic system. Clean dirt and chaff from the outside of the engine's cylinder head fins and blower housing.

Important You can wash the machine with mild detergent and water. Do not pressure wash the machine. Avoid excessive use of water, especially near the control panel, engine, hydraulic pumps and motors.

3. Service the air cleaner; refer to Servicing the Air Cleaner, page 30.
4. Grease and oil the machine; refer to Greasing and Lubrication, page 33.
5. Change the crankcase oil; refer to Servicing the Engine Oil, page 30.
6. Change the hydraulic filter; refer to Servicing the Hydraulic System, page 36.
7. Check the tire pressure; refer to Checking the Tire Pressure, page 35.
8. Charge the battery; refer to Servicing the Battery page 41.
9. Scrape any heavy buildup of grass and dirt from the underside of the mower, then wash the mower with a garden hose.
10. Check the condition of the blades. Refer to Servicing the Cutting Blades on page 28.
11. Prepare the machine for storage when non-use occurs over 30 days. Prepare machine for storage as follows.

- A. Add a petroleum based stabilizer/conditioner to fuel in the tank. Follow mixing instructions from stabilizer manufacture. **Do not use an alcohol based stabilizer (ethanol or methanol).**

Note: A fuel stabilizer/conditioner is most effective when mixed with fresh gasoline and used at all times.

- B. Run engine to distribute conditioned fuel through the fuel system (5 minutes).
- C. Stop engine, allow to cool and drain the fuel tank; refer to Servicing the Fuel Tank, page 33.
- D. Restart engine and run it until it stops.
- E. Choke or prime the engine. Start and run engine until it will not start. Operate primer, if equipped on machine, several times to ensure fuel remains in primer system.
- F. Dispose of fuel properly. Recycle as per local codes.

Important Do not store stabilizer/conditioned gasoline over 90 days.

12. Remove the spark plug(s) and check its condition; refer to Servicing the Spark Plug, page 32. With the spark plug(s) removed from the engine, pour two tablespoons of engine oil into the spark plug hole. Now use the starter to crank the engine and distribute the oil inside the cylinder. Install the spark plug(s). Do not install the wire on the spark plug(s).
13. Check and tighten all bolts, nuts, and screws. Repair or replace any part that is damaged or defective.
14. Paint all scratched or bare metal surfaces. Paint is available from your Authorized Service Dealer.
15. Store the machine in a clean, dry garage or storage area. Remove the key from the ignition switch and keep it in a memorable place out of reach of children or other unauthorized users. Cover the machine to protect it and keep it clean.

Troubleshooting

Problem	Possible Causes	Corrective Action
Starter does not crank	<ol style="list-style-type: none"> 1. Blade control (PTO) is engaged. 2. Parking brake is not on. 3. Operator is not seated. 4. Battery is dead. 5. Electrical connections are corroded or loose. 6. Fuse is blown. 7. Relay or switch is defective. 	<ol style="list-style-type: none"> 1. Move blade control (PTO) to disengaged. 2. Set parking brake. 3. Sit on the seat. 4. Charge the battery. 5. Check electrical connections for good contact. 6. Replace fuse. 7. Contact Authorized Service Dealer.
Engine will not start, starts hard, or fails to keep running.	<ol style="list-style-type: none"> 1. Fuel tank is empty. 2. Choke is not on. 3. Air cleaner is dirty. 4. Spark plug wires is loose or disconnected. 5. Spark plugs are pitted, fouled, or gap is incorrect. 6. Dirt in fuel filter. 7. Dirt, water, or stale fuel is in fuel system. 	<ol style="list-style-type: none"> 1. Fill fuel tank with gasoline. 2. Move choke lever to on. 3. Clean or replace air cleaner element. 4. Install wires on spark plug. 5. Install new, correctly gapped spark plugs. 6. Replace fuel filter. 7. Contact Authorized Service Dealer.
Engine loses power.	<ol style="list-style-type: none"> 1. Engine load is excessive. 2. Air cleaner is dirty. 3. Oil level in crankcase is low. 4. Cooling fins and air passages under engine blower housing are plugged. 5. Spark plugs are pitted, fouled, or gap is incorrect. 6. Vent in fuel cap is closed. 7. Dirt in fuel filter. 8. Dirt, water, or stale fuel is in fuel system. 	<ol style="list-style-type: none"> 1. Reduce ground speed. 2. Clean air cleaner element. 3. Add oil to crankcase. 4. Remove obstruction from cooling fins and air passages. 5. Install new, correctly gapped spark plugs. 6. Open vent in fuel cap. 7. Replace fuel filter. 8. Contact Authorized Service Dealer.
Engine overheats.	<ol style="list-style-type: none"> 1. Engine load is excessive. 2. Oil level in crankcase is low. 3. Cooling fins and air passages under engine blower housing are plugged. 	<ol style="list-style-type: none"> 1. Reduce ground speed. 2. Add oil to crankcase. 3. Remove obstruction from cooling fins and air passages.

Problem	Possible Causes	Corrective Action
Machine does not drive.	<ol style="list-style-type: none"> 1. Traction belt is worn, loose or broken. 2. Traction belt is off pulley. 3. Hydro fluid level low. 	<ol style="list-style-type: none"> 1. Contact Authorized Service Dealer. 2. Contact Authorized Service Dealer. 3. Add hydro fluid to reservoir.
Abnormal vibration.	<ol style="list-style-type: none"> 1. Cutting blade(s) is/are bent or unbalanced. 2. Blade mounting bolt is loose. 3. Engine mounting bolts are loose. 4. Loose engine pulley, idler pulley, or blade pulley. 5. Engine pulley is damaged. 6. Blade spindle bent. 	<ol style="list-style-type: none"> 1. Install new cutting blade(s). 2. Tighten blade mounting bolt. 3. Tighten engine mounting bolts. 4. Tighten the appropriate pulley. 5. Contact Authorized Service Dealer. 6. Contact Authorized Service Dealer.
Uneven cutting height.	<ol style="list-style-type: none"> 1. Blade(s) not sharp. 2. Cutting blade(s) is/are bent. 3. Mower is not level. 4. Gage wheel not set correctly. 5. Underside of mower is dirty. 6. Tire pressure is incorrect. 7. Blade spindle bent. 	<ol style="list-style-type: none"> 1. Sharpen blade(s). 2. Install new cutting blade(s). 3. Level mower from side-to-side and front-to-rear. 4. Adjust gage wheel height. 5. Clean the underside of the mower. 6. Adjust tire pressure. 7. Contact Authorized Service Dealer.
Blades do not rotate.	<ol style="list-style-type: none"> 1. Drive belt is worn, loose or broken. 2. Drive belt is off pulley. 3. Deck belt is worn, loose or broken. 4. Deck belt is off pulley. 	<ol style="list-style-type: none"> 1. Install new drive belt. 2. Install drive belt and check adjusting shafts and belt guides for correct position. 3. Install new deck belt. 4. Install deck pulley and check the idler pulley, idler arm and spring for correct position and function.



LCE

The Toro Total Coverage Guarantee

A Limited Warranty

Conditions and Products Covered

The Toro Company and its affiliate, Toro Warranty Company, pursuant to an agreement between them, jointly promise to repair the listed Toro Products if defective in materials or workmanship. The following time periods apply from the date of purchase:

<u>Products</u>	<u>Warranty Period</u>
• All Products	1 year
• All Spindles	2 years parts and labor; third year, parts only
• Engines/Hydraulic Systems* on the following: Outfront and Mid-Mount Z's ProLine Mid-Size Mowers Groundsmaster® Riding Mowers Backpack Blowers	2 years
• Deck Shells (36"-72") on the following: ProLine Mid-Size Mowers Mid-Mount Z's	2 years
• Electric Clutch on 200 Series Mid-Mount Z's	2 years

This warranty includes the cost of parts and labor, but you must pay transportation costs.

This warranty applies to:

- Outfront and Mid-Mount Z's
- ProLine Mid-Size Mowers
- Groundsmaster Riding Mowers
- Turf Maintenance Equipment
- Debris Management Equipment

* Some engines used on Toro LCE Products are warranted by the engine manufacturer.

Instructions for Obtaining Warranty Service

If you think that your Toro Product contains a defect in materials or workmanship, follow this procedure:

1. Contact any Toro Authorized or Master Service Dealer to arrange service at their dealership. To locate a dealer convenient to you, access our website at www.Toro.com. U.S. Customers may also call 800-348-2424.
2. Bring the product and your proof of purchase (sales receipt) to the Service Dealer.

If for any reason you are dissatisfied with the Service Dealer's analysis or with the assistance provided, contact us at:

LCB Customer Service Department
Toro Warranty Company
8111 Lyndale Avenue South
Bloomington, MN 55420-1196
888-577-7466 (U.S. customers)
877-484-9255 (Canada customers)

Countries Other than the United States or Canada

Customers who have purchased Toro products exported from the United States or Canada should contact their Toro Distributor (Dealer) to obtain guarantee policies for your country, province, or state. If for any reason you are dissatisfied with your Distributor's service or have difficulty obtaining guarantee information, contact the Toro importer. If all other remedies fail, you may contact us at Toro Warranty Company.

Owner Responsibilities

You must maintain your Toro Product by following the maintenance procedures described in the operator's manual. Such routine maintenance, whether performed by a dealer or by you, is at your expense.

Items and Conditions Not Covered

There is no other express warranty except for special emission system coverage on some products. This express warranty does not cover the following:

- Cost of regular maintenance service or parts, such as filters, fuel, lubricants, tune-up parts, blade sharpening, brake and clutch adjustments.
- Any product or part which has been altered or misused or required replacement or repair due to normal wear, accidents, or lack of proper maintenance.
- Repairs necessary due to improper fuel, contaminants in the fuel system, or failure to properly prepare the fuel system prior to any period of non-use over three months.
- Pickup and delivery charges.

All repairs covered by this warranty must be performed by an Authorized Toro Service Dealer using Toro approved replacement parts.

General Conditions

Repair by an Authorized Toro Service Dealer is your sole remedy under this warranty.

Neither The Toro Company nor Toro Warranty Company is liable for indirect, incidental or consequential damages in connection with the use of the Toro Products covered by this warranty, including any cost or expense of providing substitute equipment or service during reasonable periods of malfunction or non-use pending completion of repairs under this warranty.

Some states do not allow exclusions of incidental or consequential damages, or limitations on how long an implied warranty lasts, so the above exclusions and limitations may not apply to you.

All implied warranties of merchantability (that the product is fit for ordinary use) and fitness for use (that the product is fit for a particular purpose) are limited to the duration of the express warranty.

This warranty gives you specific legal rights, and you may also have other rights which vary from state to state.