



# Z257

## Z Master<sup>®</sup> with 62in SFS Side Discharge Mower

Model No. 74231—230006001 and Up

## Parts Catalog

### Ordering Replacement Parts

To order replacement parts, please supply: the part number, the quantity, and the description of each part desired.

### Understanding Reference Numbers

Each identified part in an illustration has a reference number. The reference number for a part also appears in the parts list, along with other information about the part.

This catalog uses two special reference number formats, one to indicate parts in a service assembly and another to indicate the quantity of a given part in an illustration.

### Service Assembly Reference Numbers

Parts in service assemblies have reference numbers in the form **a:b**. The **a** represents the reference number of the entire service assembly and the **b** represents a sequential number unique to each part within the service assembly.

For example, a wheel assembly might be identified by reference number **6**, the tire by **6:1**, the valve by **6:2**, and the wheel by **6:3**. When you order the assembly identified by reference number **6**, you receive all parts identified by reference numbers **6:1**, **6:2**, and **6:3**. However, you may also order any part individually.

Reference numbers of this type appear in illustrations and in part lists.

### Reference Numbers Indicating Quantity

In an illustration, if a reference number indicates more than one part, the reference number has the form **nX y**. The **n** represents the quantity of the part, the **X** is the multiplication symbol, and the **y** represents the reference number.

For example, in an illustration, the reference number **2X 37** means that two of the parts identified by reference number **37** are indicated.

## Contents

<b>Description</b>	<b>Page</b>
Front Frame Assembly .....	4
Caster and Wheel Assembly .....	5
Rear Frame and Wheel Assembly .....	6
Brake and Wheel Hub Assembly .....	7
Steering Control Assembly .....	8
Hydraulic System Assembly .....	9
Seat Assembly .....	11
Seat Assembly No. 1-633705 .....	12
Frame and Deck Assembly .....	13
Idler Assembly .....	14
Stand Assembly .....	15
Clutch Assembly .....	16
Shield Assembly .....	17
Fuel System Assembly .....	18
Electrical System Assembly .....	19
Deck and Wheel Gage Assembly .....	20
Deck Assembly No. 106-5864 .....	21
Spindle and Pulley Assembly .....	22
Belt and Idler Arm Assembly .....	23
Electrical Schematic .....	24
Group 1 – Crankshaft Assembly Kohler CH740-0007 .....	25

<b>Description</b>	<b>Page</b>
Group 2 – Crankcase Assembly Kohler CH740-0007 .....	26
Group 3 – Oil Pan/Lubrication Assembly Kohler CH740-0007 .....	27
Group 4 – Head/Valve/Breather Assembly Kohler CH740-0007 .....	28
Group 5 – Ignition/Electrical Assembly Kohler CH740-0007 .....	30
Group 6 – Blower Housing Assembly Kohler CH740-0007 .....	31
Group 7 – Starter Assembly Kohler CH740-0007 .....	32
Group 8 – Fuel System Assembly Kohler CH740-0007 .....	33
Group 9 – Engine Control Assembly Kohler CH740-0007 .....	34
Group 10 – Air Intake/Filtration Assembly Kohler CH740-0007 .....	35
Group 11 – Exhaust Assembly Kohler CH740-0007 .....	36

## Accessories

<b>Description</b>	<b>Model / Part No.</b>	<b>Description</b>	<b>Model / Part No.</b>
Suspension Seat Kit .....	99-8522	Spark Arrester Kit .....	105-1672
Striping Kit .....	30163	Filter Minder .....	99-4664
Hitch Kit .....	99-8925	DFS Bagger .....	78491
Atomic Blade Assembly .....	104-1303	Boot and Tube Kit (For DFS Bagger) .....	78495
Z Recycler Kit .....	100-9600	ROPS .....	TORO Dealer

SUPERCEDED

## Part Description Abbreviations

Part descriptions in this catalog may include the following abbreviations.

<b>Abbreviation</b>	<b>Meaning</b>	<b>Abbreviation</b>	<b>Meaning</b>
AR .....	as required	HWHTF .....	hex washer head thread forming
ASM .....	assembly	INC .....	incorporated
CARR .....	carriage	LH .....	left hand
DEG .....	degrees	NI .....	nylon insert
FH .....	flat head	PPH .....	Phillips pan head
GA .....	gauge	PTH .....	Phillips truss head
HF .....	hex flange	PTO .....	power take off
HH .....	hex head	RH .....	right hand
HHF .....	hex head flange	SFH .....	slotted fillister head
HLH .....	hex lag head	SHH .....	slotted hex head
HJ .....	hex jam	SQH .....	square head
HOC .....	height-of-cut	SHWH .....	slotted hex washer head
HS .....	hex socket	SPH .....	slotted pan head
HSBH .....	hex socket button head	SRH .....	slotted round head
HSFH .....	hex socket flat head	STD .....	standard
HSH .....	hex socket head	TAP .....	self tapping
HWH .....	hex washer head	TTH .....	Torx truss head

*SUPERCEDED*

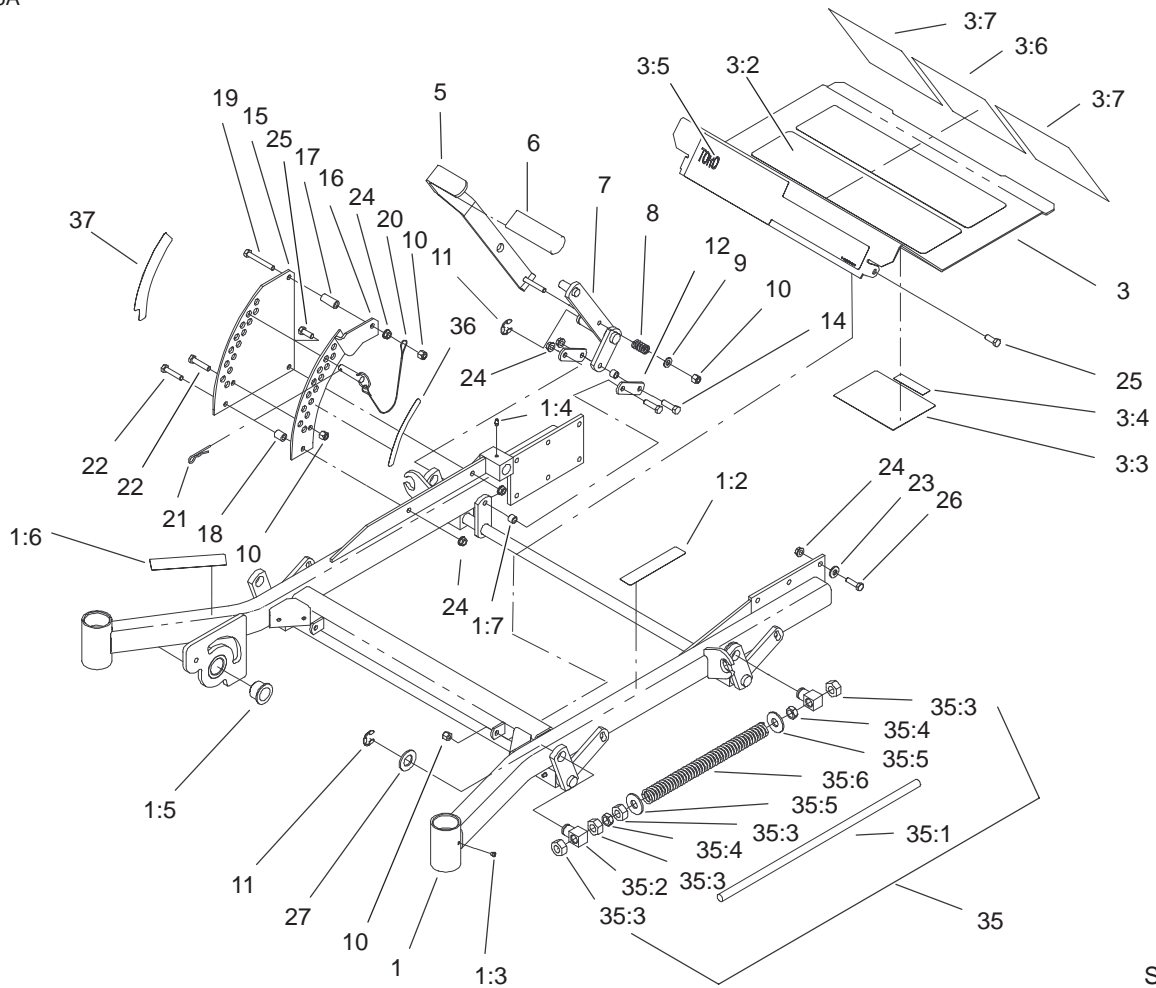

## Front Frame Assembly

Sheet No.:2

Ref. No.	Part No.	Qty.	Description
1	104-5132	1	Frame ASM
1:2	1-633818	1	Decal-Warning
1:3	1-811010	2	Plug
1:4	302-19	5	Fitting-Grease
1:5	94-1291	2	Bushing-Special
1:6	104-7759	1	Decal-Warning
1:7	103-1918	1	Bushing
3	106-6587	1	Floorpan ASM
3:2	1-633553	2	Pad-Antiskid
3:3	1-633766	1	Decal-Check
3:4	98-5954	1	Decal-Missing, Cover
3:5	1-633737	1	Decal-Z Master
3:6	106-6571	1	Decal - Danger, Slope
3:7	106-6572	2	Pad, Anti Skid
5	103-2083-03	1	Lever-Lift
6	1-633295	1	Grip-Lever, Lift
7	103-2064-03	1	Arm-Lift, Deck
8	1-633325	1	Spring-Compression
9	3256-24	1	Washer-Flat
10	3296-39	5	Nut-Lock, NI
11	32151-103	5	Ring-Snap
12	1-633068	2	Arm-Lift, Deck
14	323-29	2	Screw-HH
15	1-633889-01	1	Plate-Lift, Deck
16	1-632899-01	1	Plate-Lift, Deck
17	1-633082	1	Bushing-Lever, Lift

Ref. No.	Part No.	Qty.	Description
18	1-633080	1	Bushing-Lever, Lift
19	323-13	1	Screw-HH
20	1-633097	1	Pin-Hitch W/Lanyard
21	1-806005	1	Pin-Hair
22	323-9	2	Screw-HH
23	98-5975	12	Washer-Belleville
24	3290-357	17	Nut-HHF
25	323-6	3	Screw-HH
26	323-7	12	Screw-HH
27	3256-29	4	Washer-Flat
☆35		2	Front Frame Spring ASM
35:1	1-633096	1	Rod-Lift, Deck
35:2	1-633441	2	Swivel-Deck Mount, Rear
35:3	3217-11	4	Nut-Hex
35:4	3218-6	2	Nut-Jam
35:5	3256-7	2	Washer-Flat
35:6	1-633064	1	Spring-Support, Deck
36	1-633706	1	Decal-Height, Deck
37	1-633345	1	Decal-Height, Deck

☆ Not serviced separately

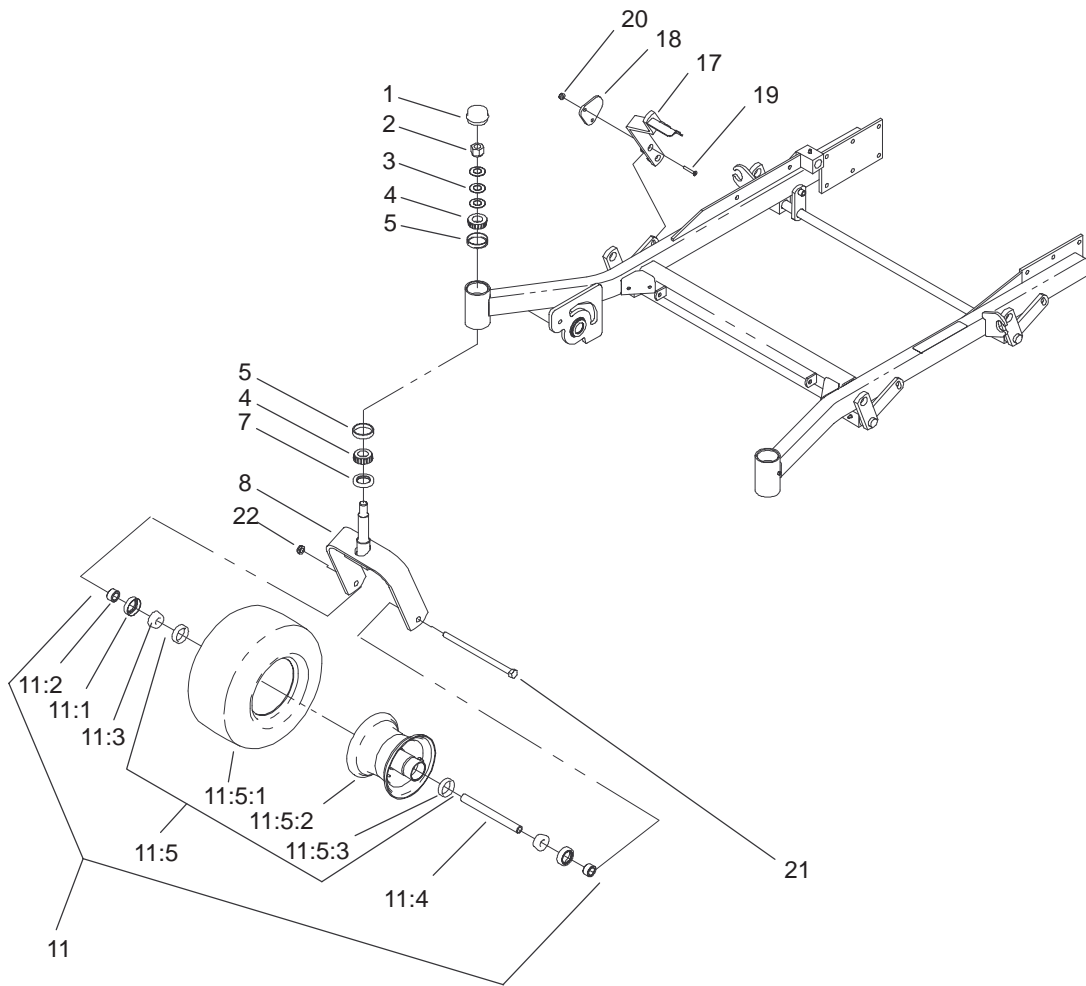

Sheet No.:3

### Caster and Wheel Assembly

Ref. No.	Part No.	Qty.	Description	Ref. No.	Part No.	Qty.	Description
1	1-543513	2	Cap-Grease				
2	3296-51	2	Nut-Lock, NI				
3	1-633508	6	Washer-Bellville				
4	254-94	4	Bearing-Cone, Taper				
5	254-72	4	Bearing-Cup, Tapered				
7	1-543511	2	Seal-Grease				
8	103-1474-01	2	Fork-Caster				
11	1-644251	2	Caster Wheel ASM				
11:1	1-633580	2	Seal-Bearing				
11:2	1-633581	2	Spacer-Bearing				
11:3	1-633585	2	Bearing-Cone, Taper				
11:4	1-633959	1	Spacer-Caster, Front				
☆11:5		1	Wheel And Tire ASM				
11:5:1	1-523009	1	Tire				
11:5:2	1-633987	1	Wheel				
11:5:3	1-633584	2	Bearing-Cup				
17	100-4333-01	1	Lever-Lift, Deck				
18	1-643220-01	1	Strap				
19	3289-7	2	Screw				
20	32128-20	2	Nut-HF				
21	325-39	2	Screw-HH				
22	3296-45	2	Nut-Lock, NI				

☆ Not serviced separately

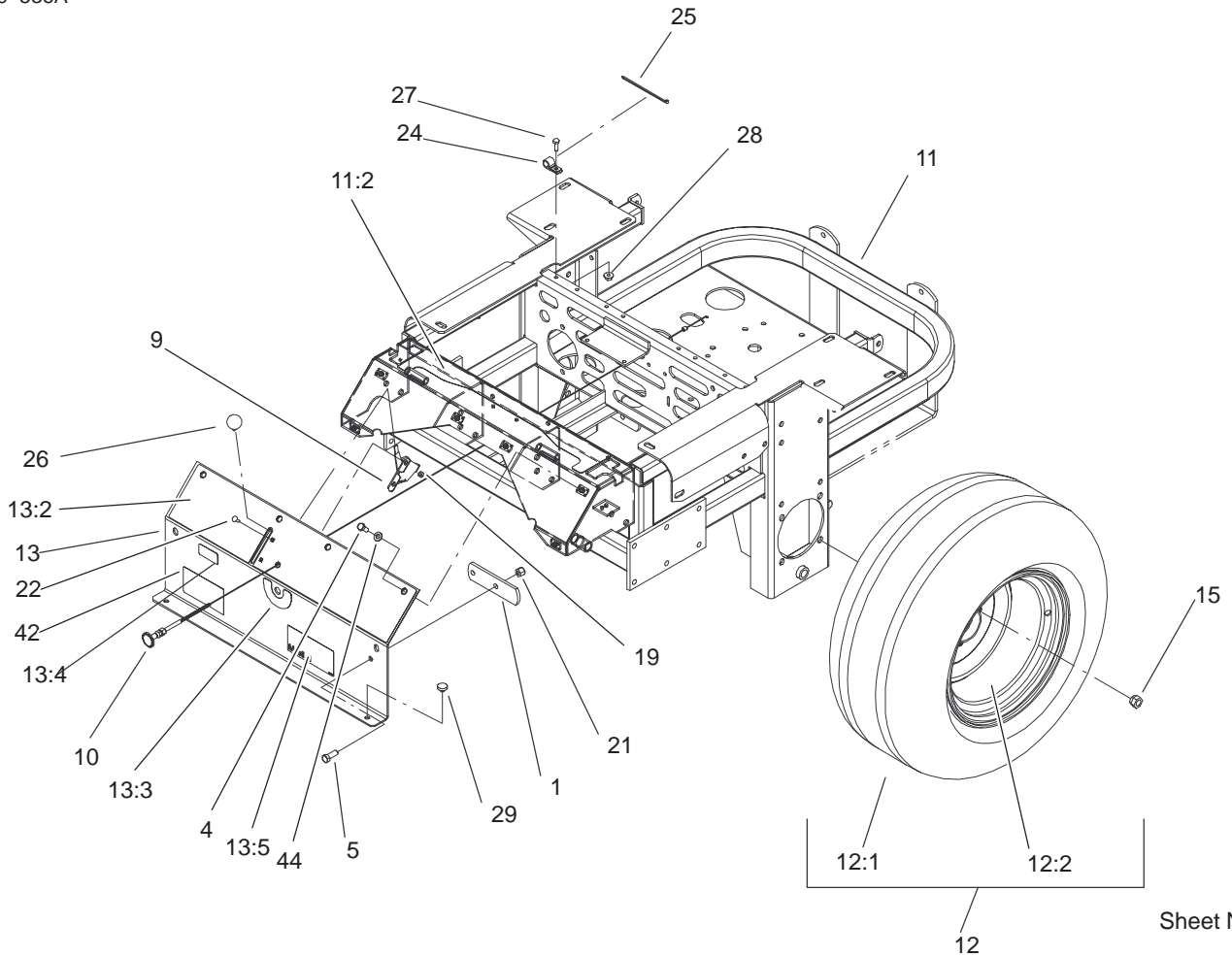

Sheet No.:4

## Rear Frame and Wheel Assembly

Ref. No.	Part No.	Qty.	Description
1	1-633964-03	1	Stop-Brake, Park
4	322-3	6	Screw-HH
5	323-6	2	Screw-HH
9	1-633696	1	Cable-Throttle
10	1-603336	1	Control-Choke
11	105-3648	1	Main Frame ASM
11:2	103-2433	1	Decal-Console, Top
12	1-633970	2	Wheel And Tire ASM
12:1	1-633993	1	Tire
12:2	1-633992	1	Wheel
13	106-6584	1	Console ASM
13:2	106-6570	1	Decal-Control Panel
13:3	103-0262	1	Decal-Valve, Fuel
13:4	98-4387	1	Decal-Protection, Ear
13:5	104-8172	1	Decal-Mobil 1
15	242-50	8	Nut-Lug
19	3296-2	2	Nut-Lock
21	3296-39	2	Nut-Lock, NI
22	1-807513	2	Bolt-CARR
24	1-513762	1	Clip-Loom
25	1-303335	1	Tie-Plastic
26	1-513592	1	Knob-Ball
27	321-4	1	Screw-HH
28	32128-33	1	Nut-HF
29	1-513658	2	Bumper-Catcher, Grass

Ref. No.	Part No.	Qty.	Description
42	106-6561	1	Decal-Z257
44	3256-23	6	Washer-Flat

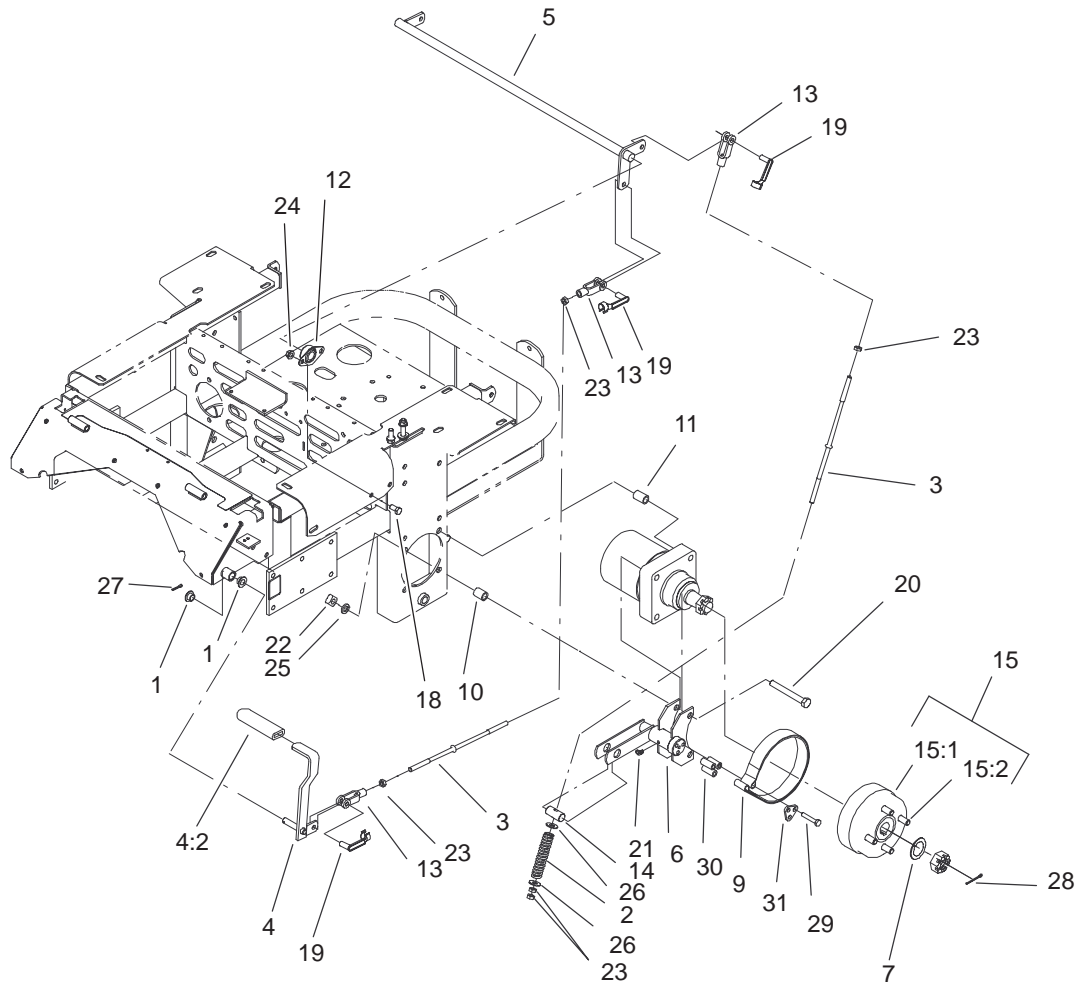

## Brake and Wheel Hub Assembly

Ref. No.	Part No.	Qty.	Description
1	1-513140	2	Bearing-Control
2	1-633454	2	Spring-Brake
3	1-633477	3	Rod-Brake
4	1-634500	1	Brake Lever ASM
4:2	1-633268	1	Grip-Lever, Brake
5	1-632217-03	1	Shaft-Brake
6	103-0352-03	2	Bracket-Brake
7	1-523157	2	Washer-Spacer
9	103-0355	2	Band-Brake
10	1-633380	4	Spacer-Wheel, Short
11	1-633382	4	Spacer-Wheel, Long
12	1-633102	2	Bearing-Flange, Side
13	1-633131	4	Yoke-Linkage, Brake
14	1-633144	2	Pin-Trunion
15	103-0590	2	Hub-Wheel
15:1	103-0589	1	Hub-Wheel
15:2	1-633926	4	Stud-Wheel
18	323-4	4	Screw-HH
19	103-2399	4	Pin-Spring, Clevis
20	325-17	8	Screw-HH
21	1481	2	Fitting-Grease
22	103-0131	8	Nut-Square
23	3219-3	8	Nut-HH
24	3290-357	4	Nut-HHF
25	3253-7	8	Washer-Lock
26	3256-4	4	Washer-Flat

Ref. No.	Part No.	Qty.	Description
27	3272-10	1	Pin-Cotter
28	1-806800	2	Pin-Cotter
29	322-9	6	Screw-HH
30	103-0384	6	Spacer
31	103-0374	2	Retainer-Band, Brake

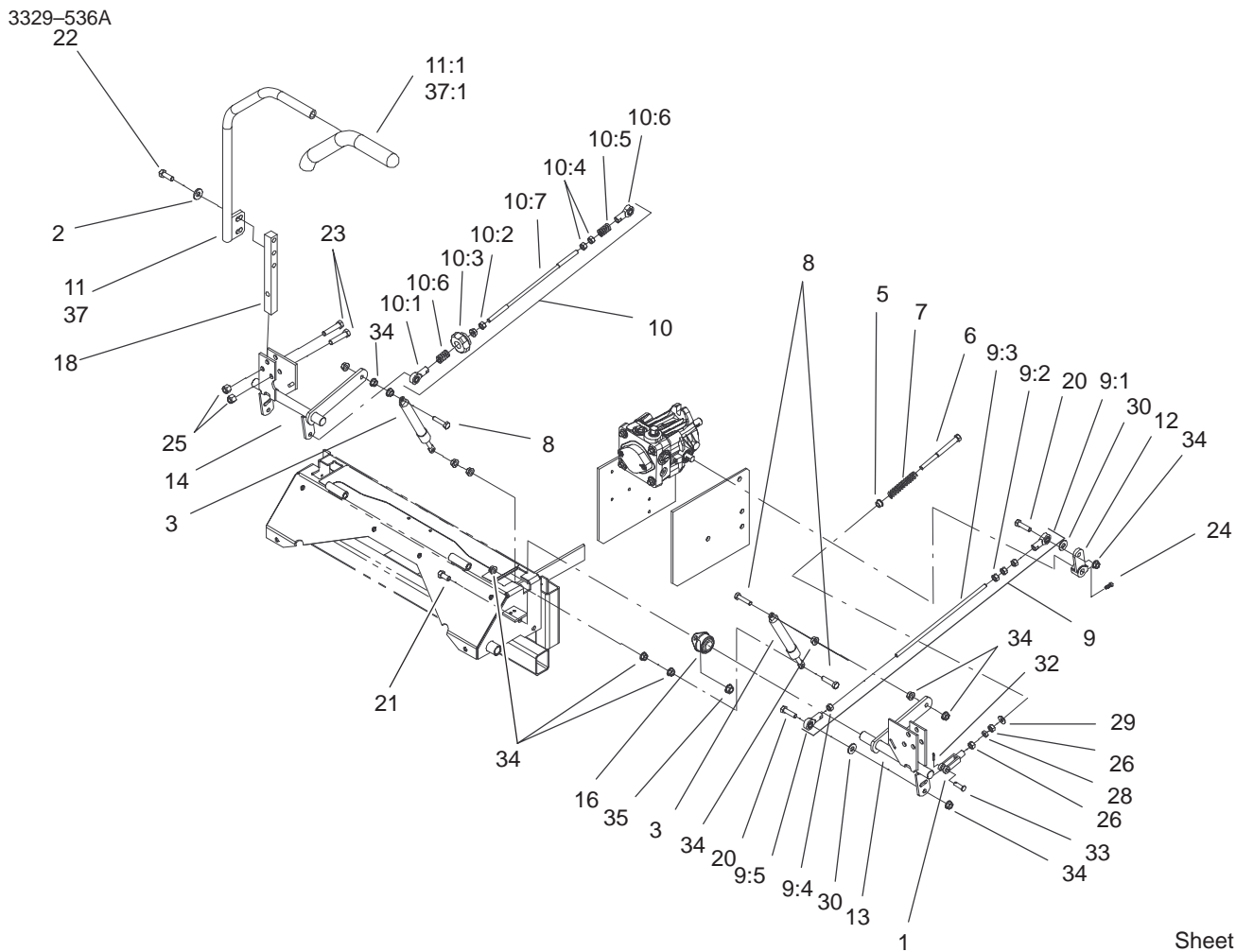

Sheet No.:6

## Steering Control Assembly

Ref. No.	Part No.	Qty.	Description
1	1-303105	2	Yoke-Adjustable
2	98-5975	4	Washer-Belleville
3	103-2913	2	Damper-Control, Motion
5	1-603735	2	Bushing-Flanged
6	1-603737	2	Bolt-Return, Neutral
7	1-603807	2	Spring-Return, Neutral
8	1-403180	4	Screw-HH
9	103-3074	1	LH Pump Linkage ASM
9:1	1-543017	1	Balljoint-RH
9:2	3219-2	3	Nut-Hex
9:3	103-3064	1	Link-Rod, Tracking
9:4	1-804524	1	Nut
9:5	1-633152	1	Balljoint-Thread, LH
10	103-3061	1	Tracking Rod ASM
10:1	1-543017	1	Balljoint-RH
10:2	3219-2	1	Nut-Hex
10:3	103-3060	1	Knob-Tracking
10:4	1-804524	2	Nut
10:5	1-323245	2	Spring-Compression
10:6	1-633152	1	Balljoint-Thread, LH
10:7	103-3064	1	Link-Rod, Tracking
11	103-0632	1	RH Lever ASM
11:1	1-633257	1	Grip-Control, Motion

Ref. No.	Part No.	Qty.	Description
12	1-632208	2	Arm-Control, Pump
13	1-642319	1	Control-Motion, LH
14	1-642320	1	Control-Motion, RH
16	1-633102	4	Bearing-Flange, Side
18	103-0407	2	Arm-Shaft, Control
20	322-6	4	Screw-HH
21	323-4	8	Screw-HH
22	323-6	4	Screw-HH
23	323-9	6	Screw-HH
24	1-803022	2	Screw-Set
25	3296-39	6	Nut-Lock, NI
26	3219-2	4	Nut-Hex
28	3220-2	2	Nut
29	3256-2	2	Washer-Flat
30	3256-3	4	Washer-Flat
32	3272-5	2	Pin-Cotter
33	1-808280	2	Pin-Clevis
34	32128-20	16	Nut-HF
35	3290-357	8	Nut-HHF
37	103-0631	1	LH Lever ASM
37:1	1-633257	1	Grip-Control, Motion





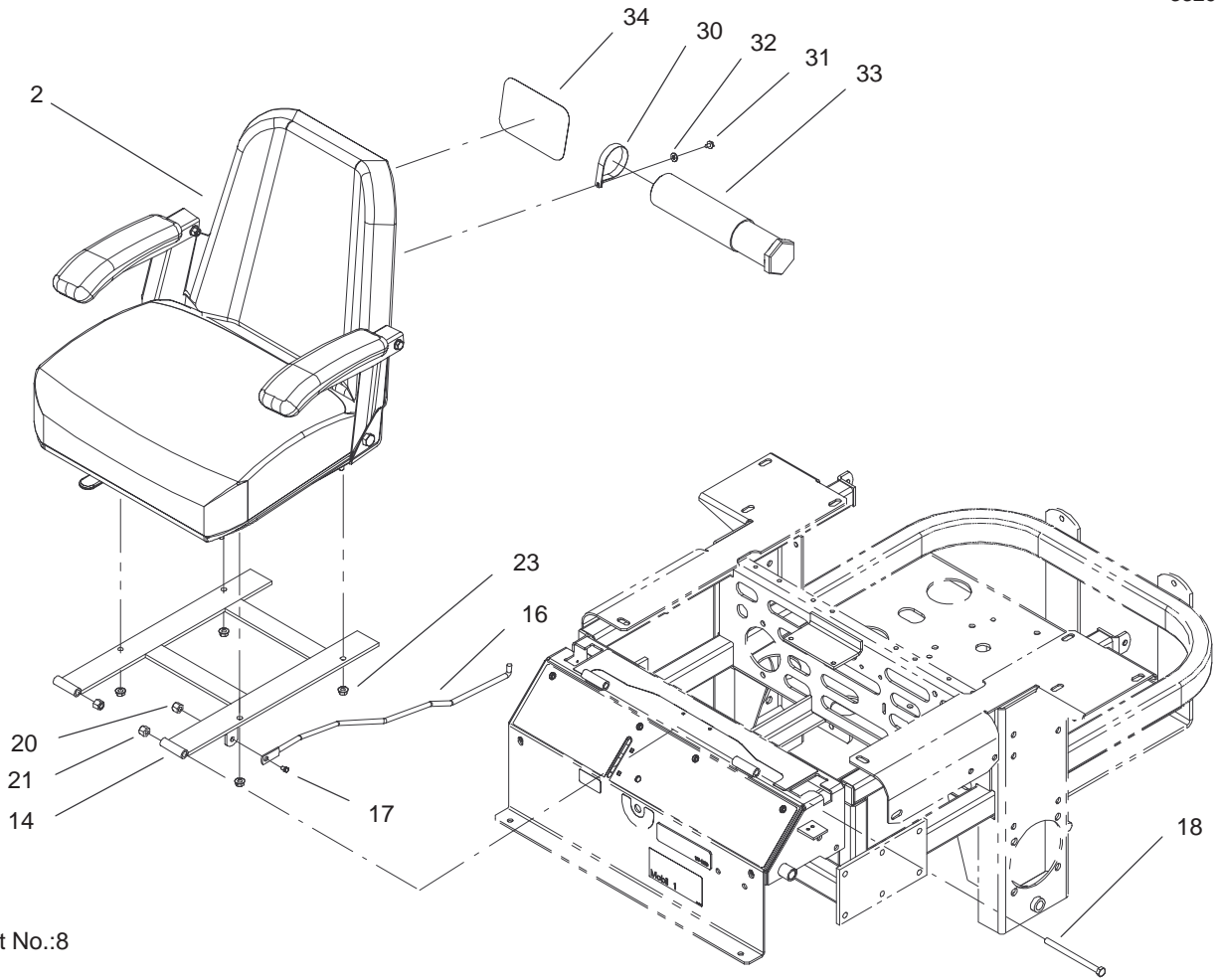

Sheet No.:8

### Seat Assembly

Ref. No.	Part No.	Qty.	Description	Ref. No.	Part No.	Qty.	Description
2	1-633705	1	Seat ASM				
14	1-632187-03	1	Frame-Seat				
16	1-633293	1	Rod-Holdup, Seat				
17	322-5	1	Screw-HH				
18	323-39	2	Screw-HH				
20	3296-29	1	Nut-Lock, NI				
21	3296-39	2	Nut-Lock, NI				
23	32128-20	4	Nut-HF				
30	2412-120	2	R-Clamp				
31	32104-76	2	Screw				
33	74-0720	1	Tube-Manual				
34	99-4693	1	Decal-Toro				



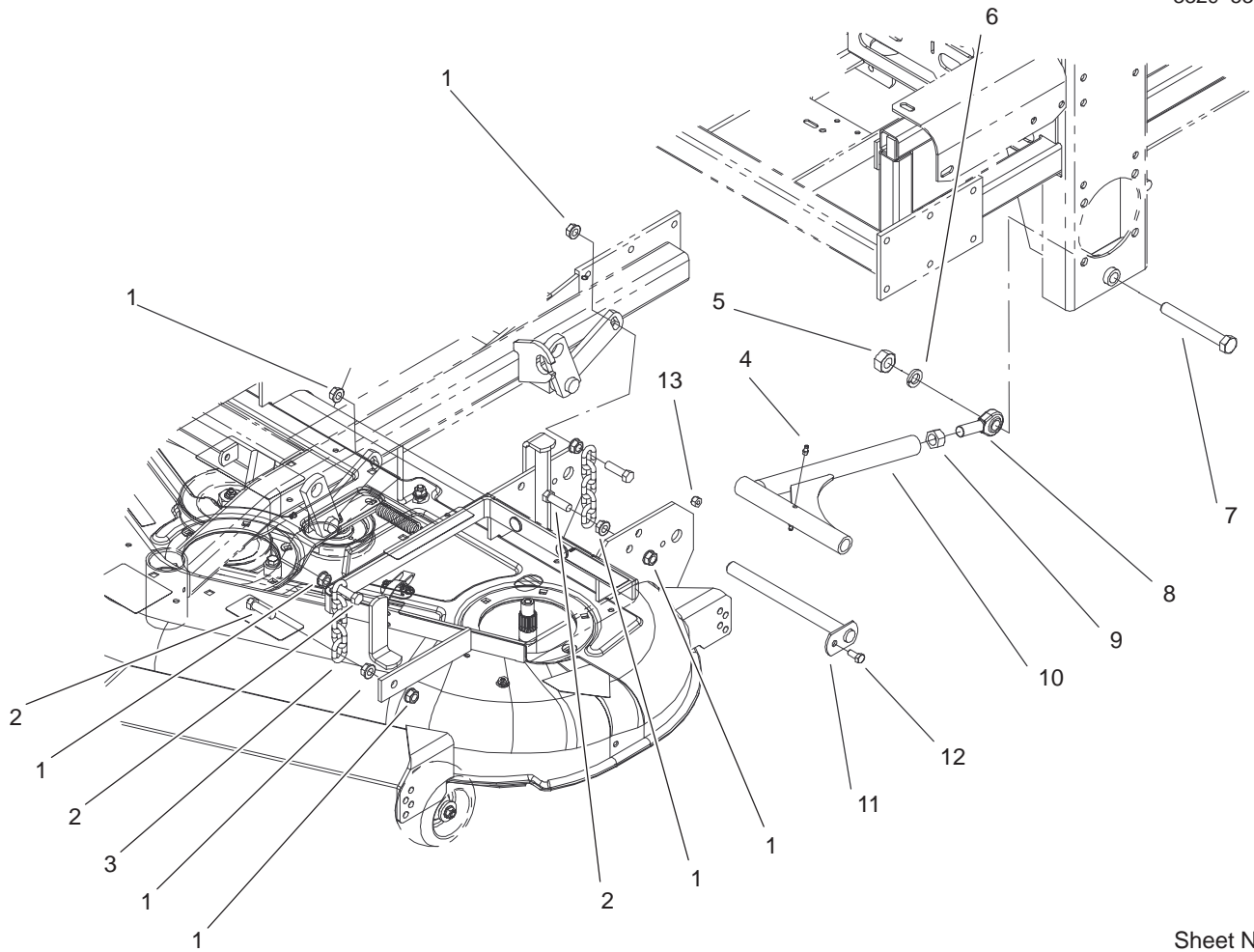

Sheet No.:9

## Frame and Deck Assembly

Ref. No.	Part No.	Qty.	Description	Ref. No.	Part No.	Qty.	Description
1	32128-37	16	Nut-HF				
2	1-800811	8	Screw-Cap, HH				
3	1-633447	4	Chain-Lift, Deck				
4	302-19	4	Fitting-Grease				
5	3217-11	2	Nut-Hex				
6	3253-8	2	Washer-Lock				
7	327-11	2	Screw-HH				
8	1-633029	2	Balljoint-Spherical				
9	3219-6	2	Nut-Hex				
10	103-1072-01	2	Strut				
11	1-632199-01	2	Pin-Strut				
12	322-3	2	Screw-HH				
13	3296-29	2	Nut-Lock, NI				



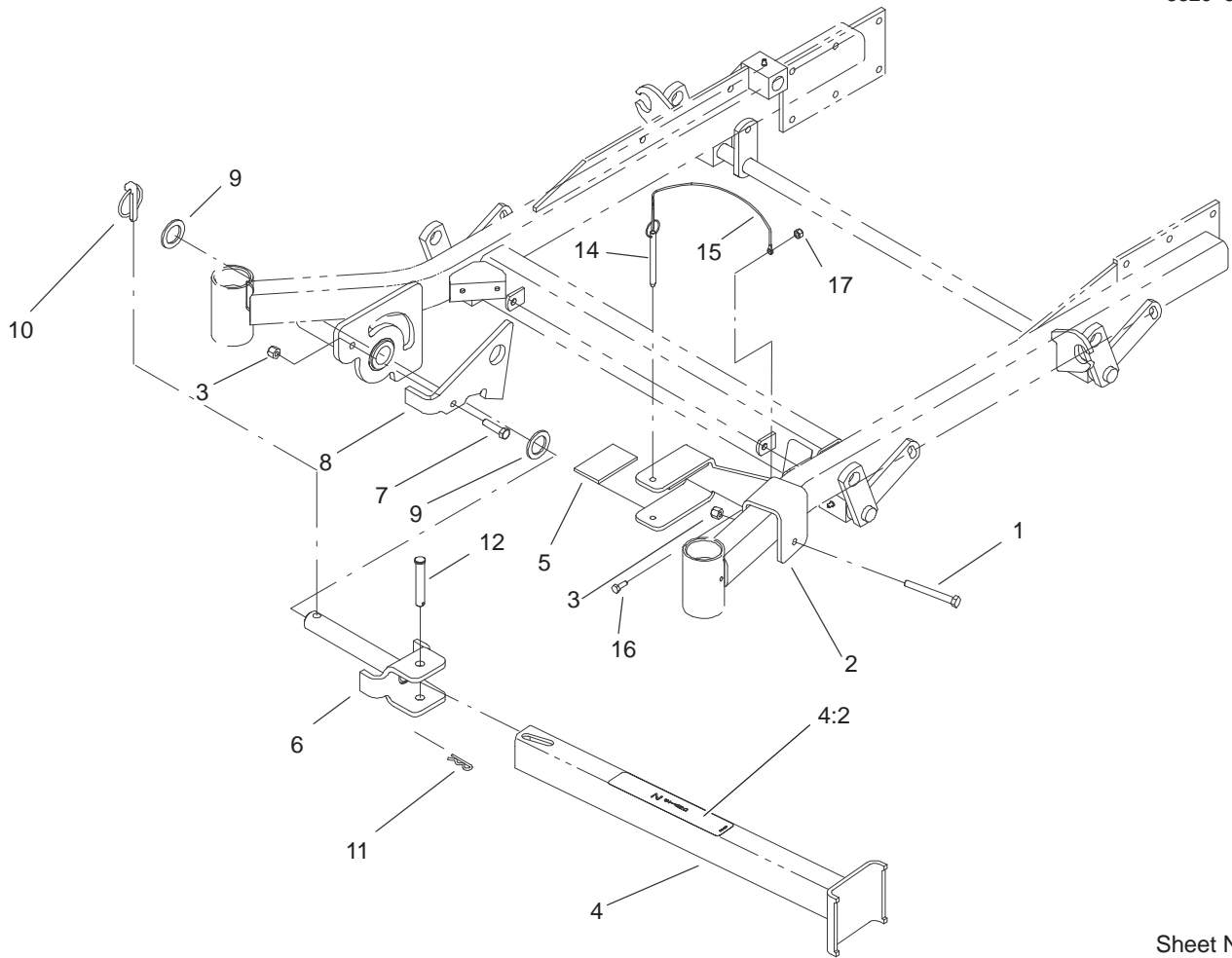

Sheet No.:11

## Stand Assembly

Ref. No.	Part No.	Qty.	Description	Ref. No.	Part No.	Qty.	Description
1	323-20	1	Screw-HH				
2	100-6542-01	1	Bracket-Cradle				
3	3296-39	2	Nut-Lock, NI				
4	100-6545	1	Leg ASM				
4:2	104-7758	1	Decal-Z Stand				
5	283-55	1	Pin-Clevis				
6	100-9692-01	1	Pivot Pin ASM				
7	323-8	1	Screw-HH				
8	100-9686-01	1	Bracket-Latch				
9	3-6781	2	Washer-Thrust				
10	283-71	1	Pin-Lynch				
11	3290-355	1	Pin-Hair				
12	100-6547	2	Cushion-Rubber				
14	105-1647	1	Pin-Hitch, Cotterless				
15	100-9385	1	Lanyard-Nylon				
16	321-4	1	Screw-HH				
17	3296-42	1	Nut-Lock, NI				

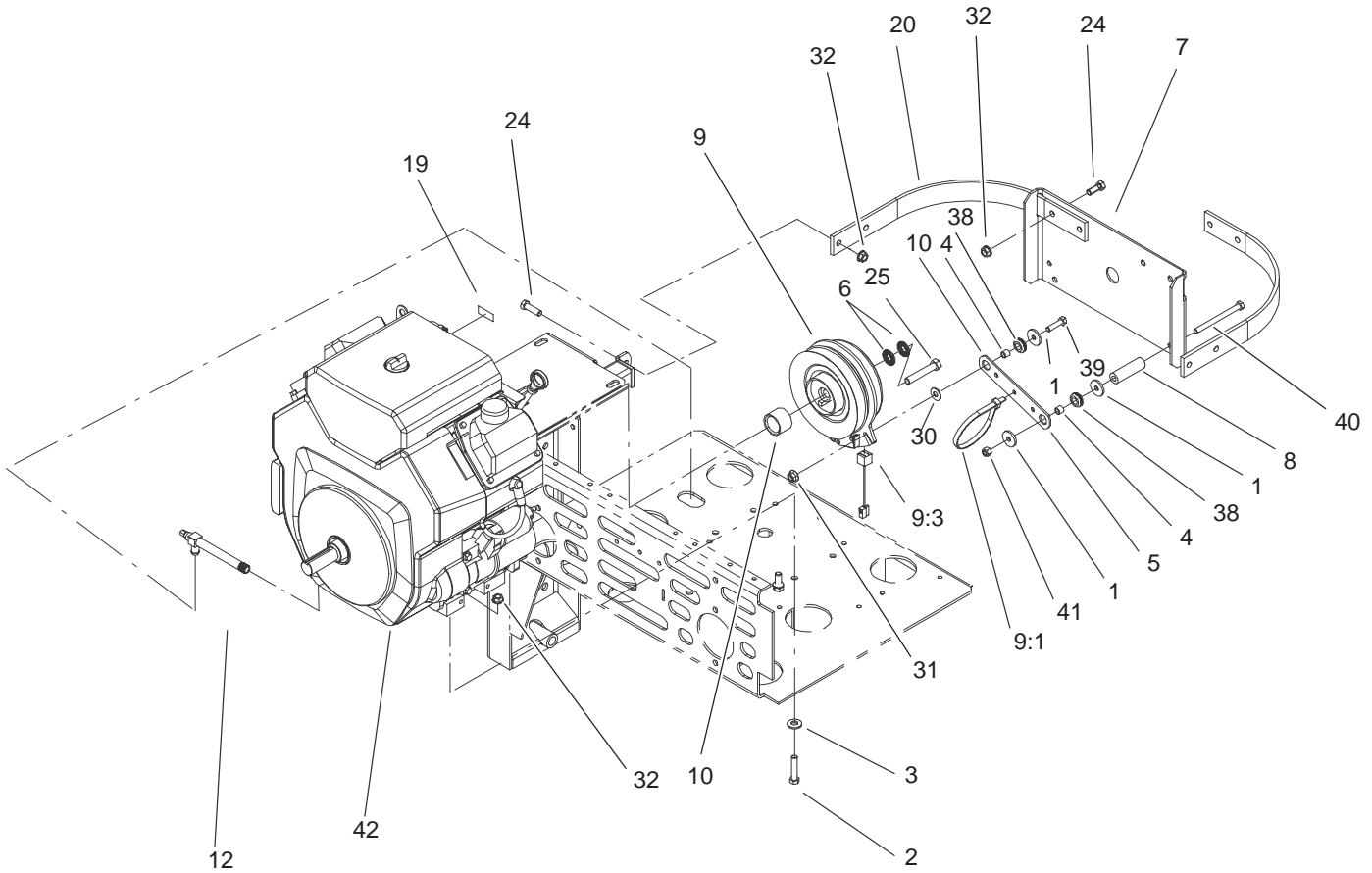

Sheet No.:12

## Clutch Assembly

Ref. No.	Part No.	Qty.	Description
1	1-613235	4	Washer
2	323-9	4	Screw-HH
3	98-5975	4	Washer-Belleville
4	1-633545	2	Spacer-Grommet
5	1-633543-03	1	Strap-Clutch, Brake
6	1-603610	2	Washer-Spring
7	1-633615-03	1	Guard-Clutch
8	1-633988	1	Spacer-Anchor, Clutch
9	103-0665	1	Clutch ASM
9:1	1-303335	1	Tie-Plastic
9:3	105-1670	1	Harness-Jumper, Clutch
10	1-633179	1	Spacer-Clutch
12	103-1996	1	Valve-Oil Drain, Long
19	103-3270	1	Decal-3750 Rpm
20	1-643264-03	2	Bracket-Guard, Top
24	323-6	6	Screw-HH
25	3212-10	1	Screw-HH
30	3256-3	1	Washer-Flat
31	32128-20	1	Nut-HF
32	3290-357	8	Nut-HHF
38	1-633630	2	Grommet-Brake
39	322-6	1	Screw-HH
40	322-19	1	Screw-HH
41	3296-29	1	Nut-Lock, NI

Ref. No.	Part No.	Qty.	Description
☆42		1	Engine-Kohler, Ch740-0007

☆ Not serviced separately

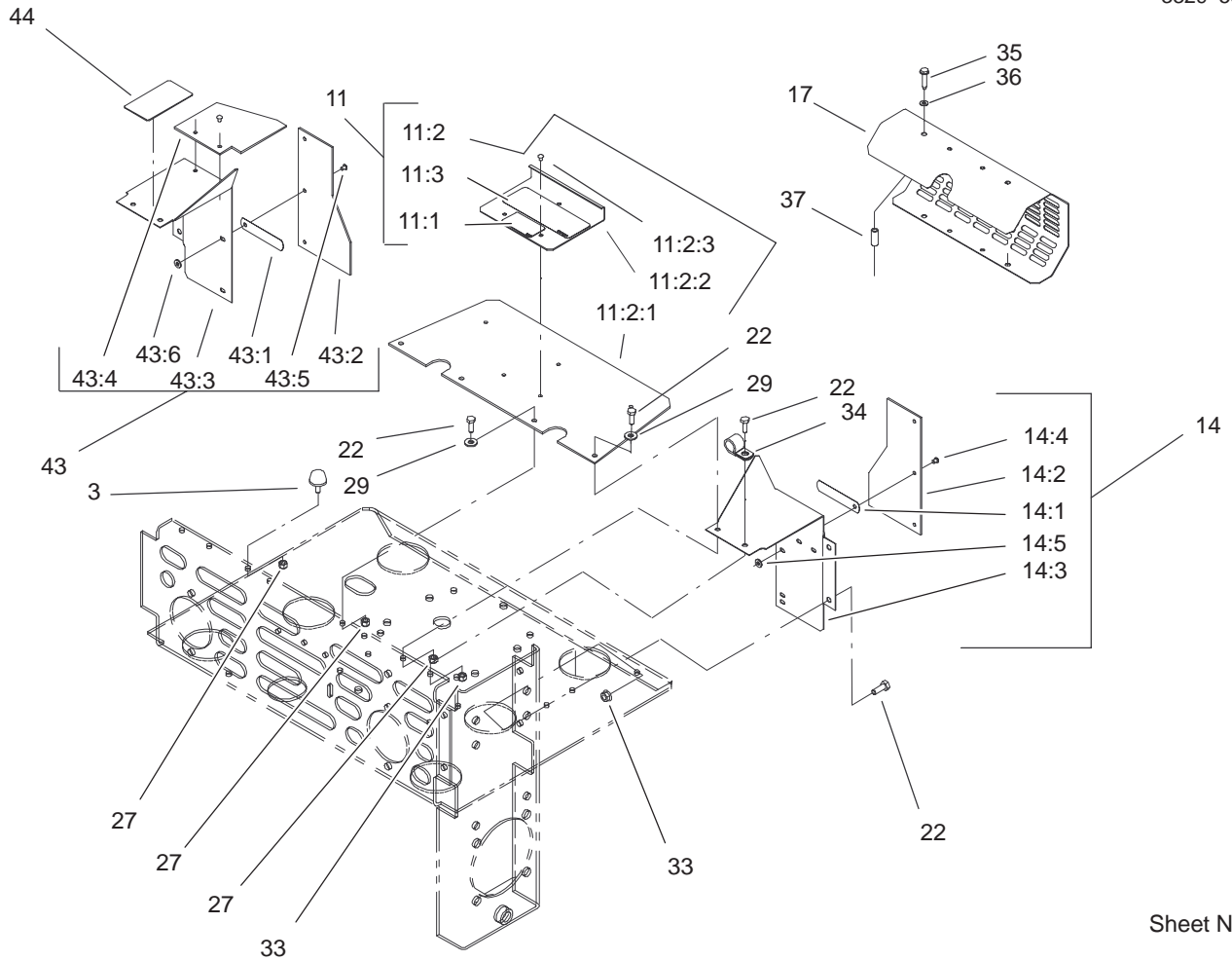

Sheet No.:13

### Shield Assembly

Ref. No.	Part No.	Qty.	Description
3	1-523420	2	Bumper
11	1-644276	1	Shield ASM
11:1	1-633462	1	Decal-Important
11:2	1-634308	1	Shield/Lift ASM
11:2:1	103-1308	1	Shield-Engine
11:2:2	1-633300-03	1	Lift-Shield
11:2:3	1-803035	3	Rivet-Pop
11:3	103-0368	1	Decal-Devices, Rotating
14	1-634796	1	LH Shield ASM
14:1	1-523285	1	Clip-Baffle, Rear
14:2	1-633301	1	Shield-Engine
14:3	1-633795-03	1	Baffle-Engine Shield, LH
14:4	1-803035	3	Rivet-Pop
14:5	3256-63	3	Washer-Flat
17	1-643313-03	1	Guard-Muffler
22	321-4	10	Screw-HH
27	3296-42	6	Nut-Lock, NI
29	3256-2	4	Washer-Flat
33	32128-33	5	Nut-HF
34	1-633396	1	Clip-Loom
35	1-809076	2	Screw
36	1-323235	2	Washer-Spring
37	1-323236	2	Spacer
43	1-644316	1	RH Shield ASM

Ref. No.	Part No.	Qty.	Description
43:1	1-523285	1	Clip-Baffle, Rear
43:2	1-633301	1	Shield-Engine
43:3	1-633794-03	1	Baffle-Engine Shield, RH
43:4	1-643315	1	Baffle-Cooler, Engine
43:5	1-803035	5	Rivet-Pop
43:6	3256-63	5	Washer-Flat
44	1-643339	1	Decal-Routing, Belt



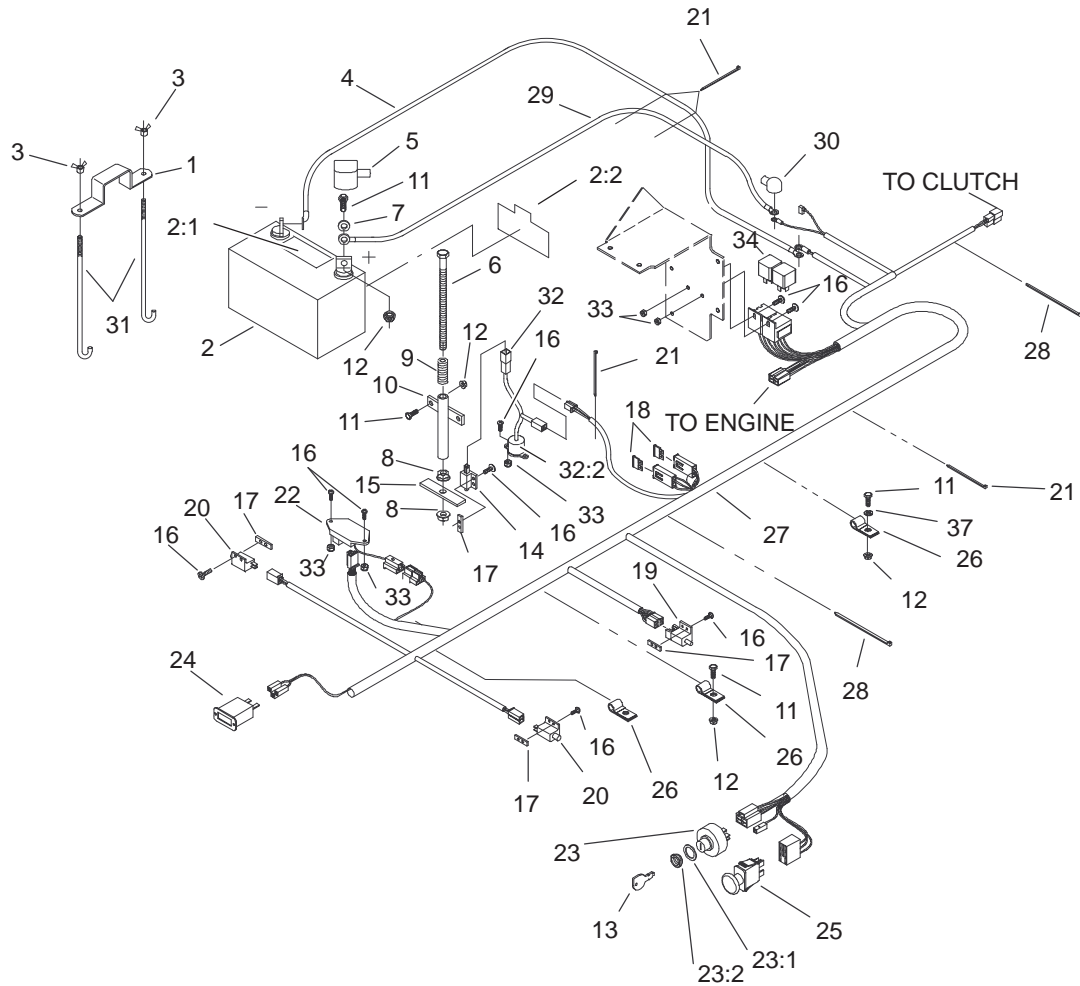

Sheet No.:27

## Electrical System Assembly

Ref. No.	Part No.	Qty.	Description	Ref. No.	Part No.	Qty.	Description
1	1-633652-03	1	Strap-Holddown	23	88-9830	1	Key Switch ASM
2	105-1692	1	Battery	23:1	3254-5	1	Washer-Tooth
2:1	104-4163	1	Decal-Battery	23:2	218-461	1	Nut-HH
2:2	104-4164	1	Decal-Battery	24	1-513374	1	Meter-Hour
3	1-543792	2	Wingnut	25	1-633673	1	Switch-Delta
4	1-633307	1	Wire-Ground	26	1-633396	3	Clip-Loom
5	1-543391	1	Insulator-Battery	27	100-4340	1	Harness-Wire
6	1-800282	1	Screw-HH	28	1-303335	2	Tie-Plastic
7	3256-2	2	Washer-Flat	29	1-523281	1	Wire-Starter
8	32128-20	2	Nut-HF	30	1-543393	1	Insulator-Solenoid
9	1-523415	1	Spring-Switch, Seat	31	1-633651	2	Bolt-Holddown
10	1-522424-03	1	Mount-Spring, Seat	32	1-644427	1	Tilt Switch ASM
11	321-4	6	Screw-HH	32:2	1-643401	1	Decal-Switch, Mercury
12	32128-33	6	Nut-HF	33	3296-2	6	Nut-Lock
13	63-8360	2	Key-Ignition	34	1-643275	2	Relay
14	1-513152	1	Switch-Closed, Normally	37	3256-22	1	Washer-Flat
15	1-513180	1	Plate-Switch, Seat				
16	3290-500	14	Screw-PPH				
17	1-633181	4	Plate-Tapped				
18	1-816001	2	Fuse-Type, Blade				
19	1-633111	1	Switch				
20	1-513051	2	Switch-Open, Normally				
21	1-303287	5	Tie-Plastic				
22	100-6186	1	Module-Delay, Seat				



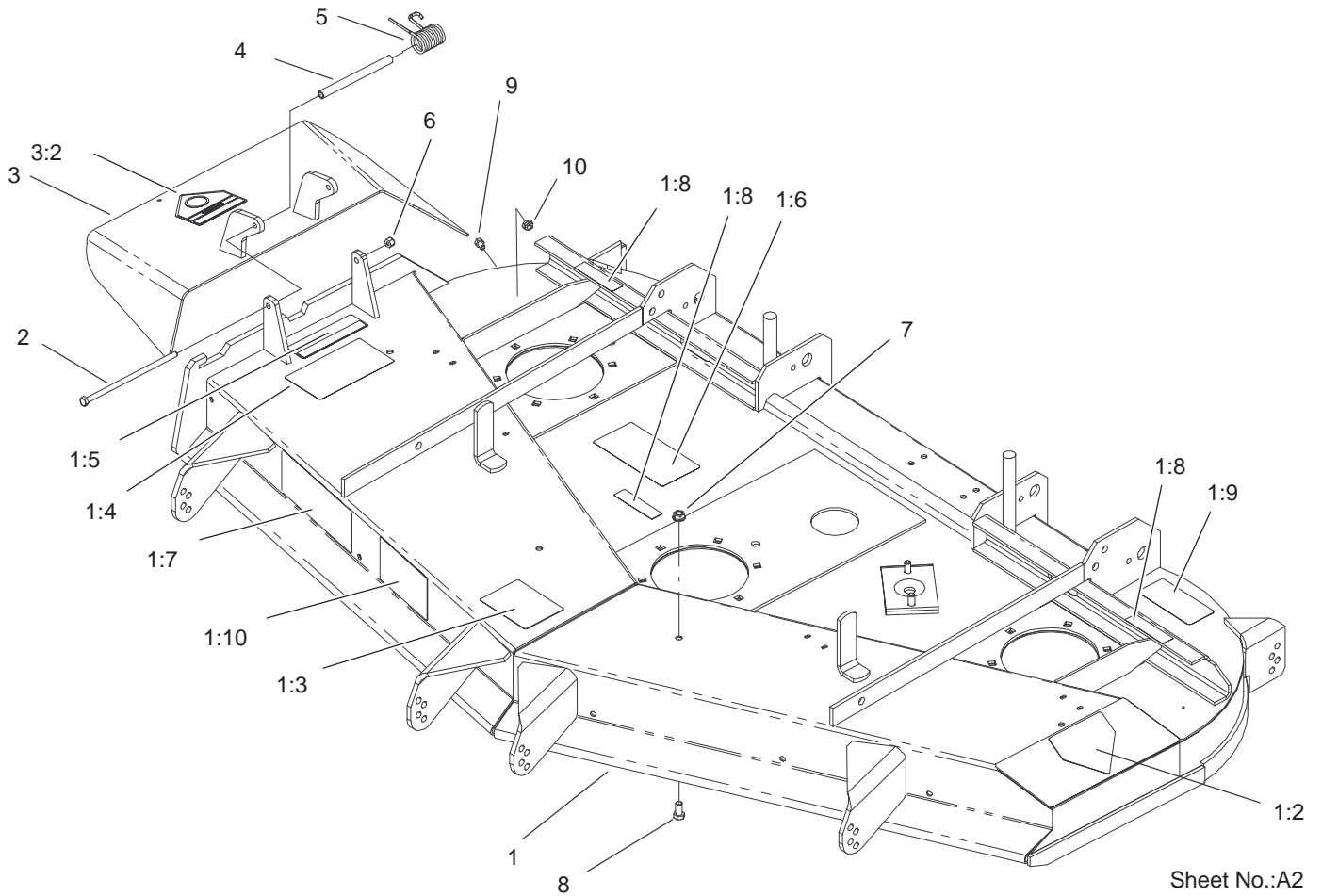

### Deck Assembly No. 106-5864

Ref. No.	Part No.	Qty.	Description	Ref. No.	Part No.	Qty.	Description
☆1		1	Deck ASM				
1:2	43-8480	1	Decal-Danger				
1:3	98-3798	1	Decal-Wheel, Gage				
1:4	66-1340	1	Decal-Danger				
1:5	104-8569	1	Decal-Warning				
1:6	99-4686	1	Decal-Routing, Belt				
1:7	99-4619	1	Decal-Sfs				
1:8	98-5954	3	Decal-Missing, Cover				
1:9	93-7818	1	Decal-Torque, Blade				
1:10	99-4620	1	Decal-Deck				
2	322-50	1	Screw-HH				
3	105-3605	1	Deflector ASM				
3:2	93-1122	1	Decal-Danger				
4	105-4622	1	Spacer				
5	104-8554	1	Spring-Torsion				
6	3296-29	1	Nut-Lock, NI				
7	3290-357	6	Nut-HHF				
8	323-2	6	Screw-HH				
9	322-1	2	Screw-HH				
10	32128-20	2	Nut-HF				

☆ Not serviced separately

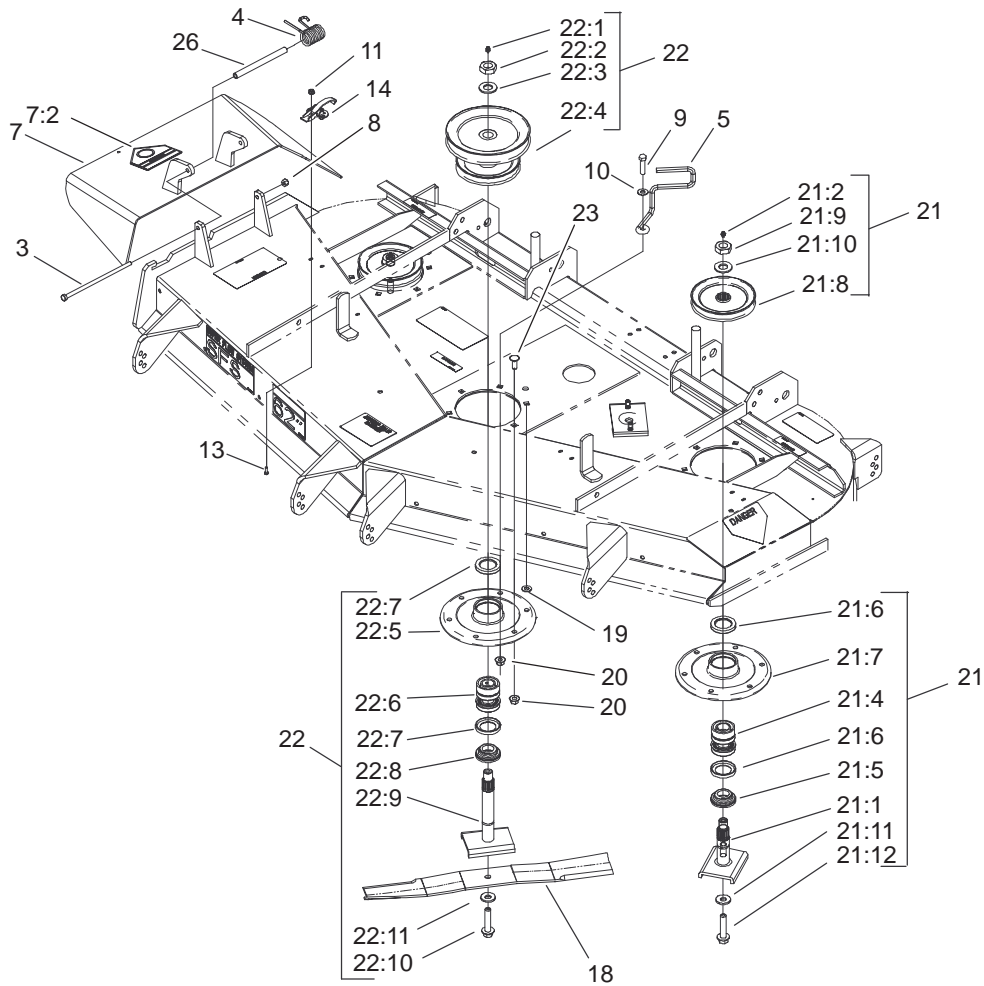

Sheet No.:62

## Spindle and Pulley Assembly

Ref. No.	Part No.	Qty.	Description
3	322-50	1	Screw-HH
4	104-8554	1	Spring-Torsion
5	99-8933	1	Guide-Belt
7	105-3605	1	Deflector ASM
7:2	93-1122	1	Decal-Danger
8	3296-29	1	Nut-Lock, NI
9	323-8	1	Screw-HH
10	3256-3	1	Washer-Flat
11	32128-17	8	Nut-Lock, Flange
13	3290-321	8	Screw-HWH
14	249-21	4	Clamp-Slotted
18	44-6250	3	Blade
19	3256-24	1	Washer-Flat
20	32128-21	18	Nut-HF
21	99-4640	2	Outer Spindle ASM
21:1	27-0920	1	Shaft
21:2	302-2	1	Fitting-Grease
21:4	46-8530	1	Bearing ASM
21:5	27-0950	1	Spacer
21:6	253-139	2	Seal-Oil
21:7	61-4160	1	Housing
21:8	99-4614	1	Pulley And Hub ASM
21:9	32146-20	1	Nut-Jam
21:10	7-4150	1	Washer
21:11	1-513435	1	Washer-Spring
21:12	92-5816	1	Bolt-Blade

Ref. No.	Part No.	Qty.	Description
22	105-1689	1	Spindle Housing ASM
22:1	302-2	1	Fitting-Grease
22:2	32146-20	1	Nut-Jam
22:3	92-5836	1	Washer
22:4	100-4307	1	Pulley/Hub ASM
22:5	61-4160	1	Housing
22:6	46-8530	1	Bearing ASM
22:7	253-139	2	Seal-Oil
22:8	27-0950	1	Spacer
22:9	105-1686	1	Spindle Shaft ASM
22:10	92-5816	1	Bolt-Blade
22:11	1-513435	1	Washer-Spring
23	3231-22	17	Screw-CARR
26	105-4622	1	Spacer

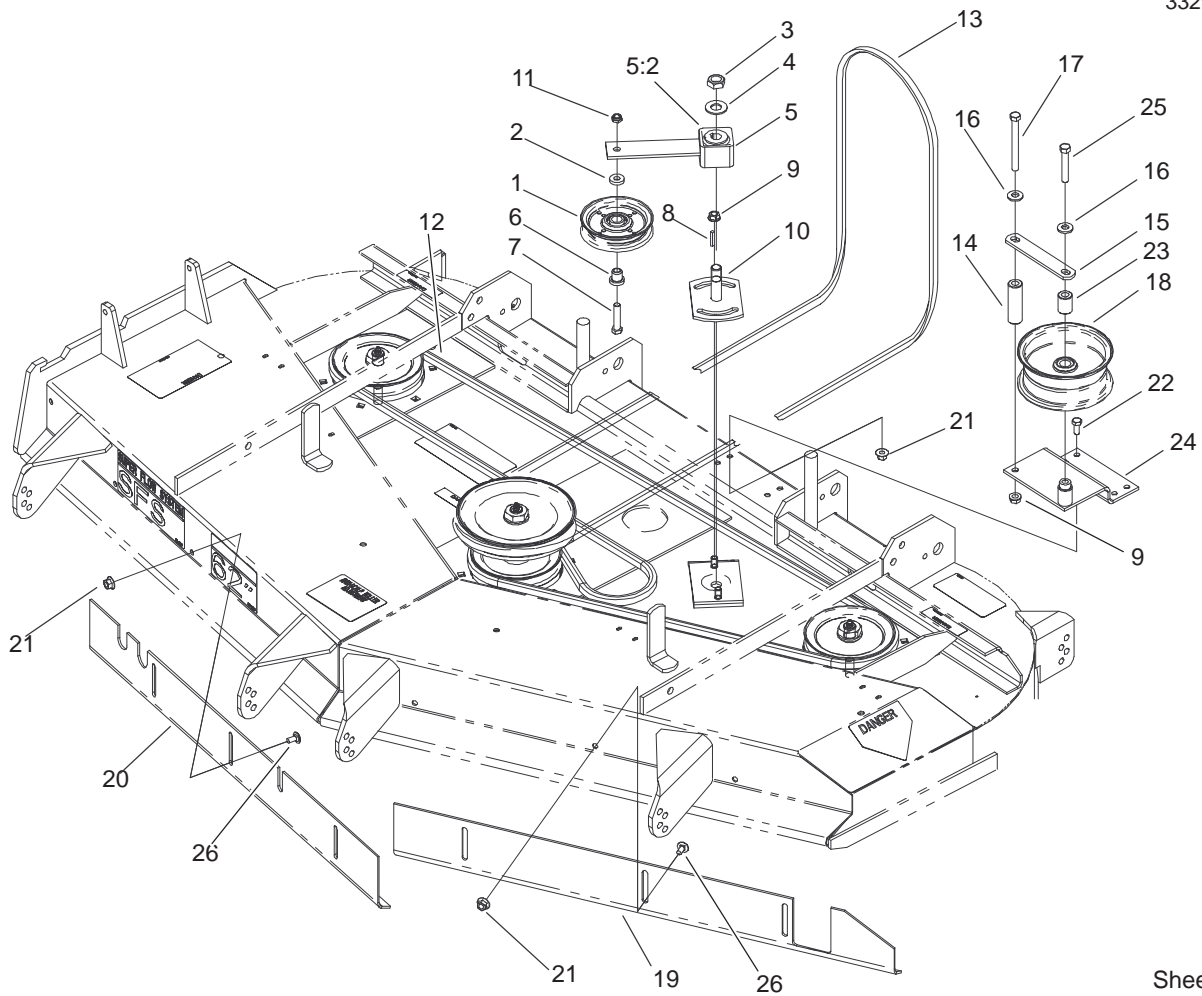

### Belt and Idler Arm Assembly

Ref. No.	Part No.	Qty.	Description
1	65-5940	1	Pulley-Idler
2	7-0081	1	Washer-Flat
3	3296-71	1	Nut-Lock NI
4	3256-27	1	Washer-Flat
5	27-8580	1	Idler Arm ASM
5:2	27-8490	1	Bushing-Rubber
6	65-5950	1	Bushing-Pulley
7	3211-8	1	Screw-HH
8	5-1077	1	Key-Square
9	3290-357	3	Nut-HHF
10	44-6301	1	Plate-Idler, LH
11	3296-5	1	Nut-Lock, NI
12	44-6260	1	V-Belt
13	99-4647	1	V-Belt-Drive, Deck
14	99-4659	1	Spacer-Bracket
15	1-653189	1	Plate
16	98-5975	2	Washer-Belleville
17	323-42	1	Screw-HH
18	1-413099	1	Pulley-Idler
19	99-2833-03	1	Baffle-Front, LH
20	99-2834-03	1	Baffle-Front, RH
21	32128-20	10	Nut-HF
22	322-3	4	Screw-HH
23	1-653190	1	Spacer
24	99-4684-01	1	Bracket-Pulley

Ref. No.	Part No.	Qty.	Description
25	323-11	1	Screw-HH
26	3230-18	6	Screw-CARR

# Electrical Schematic

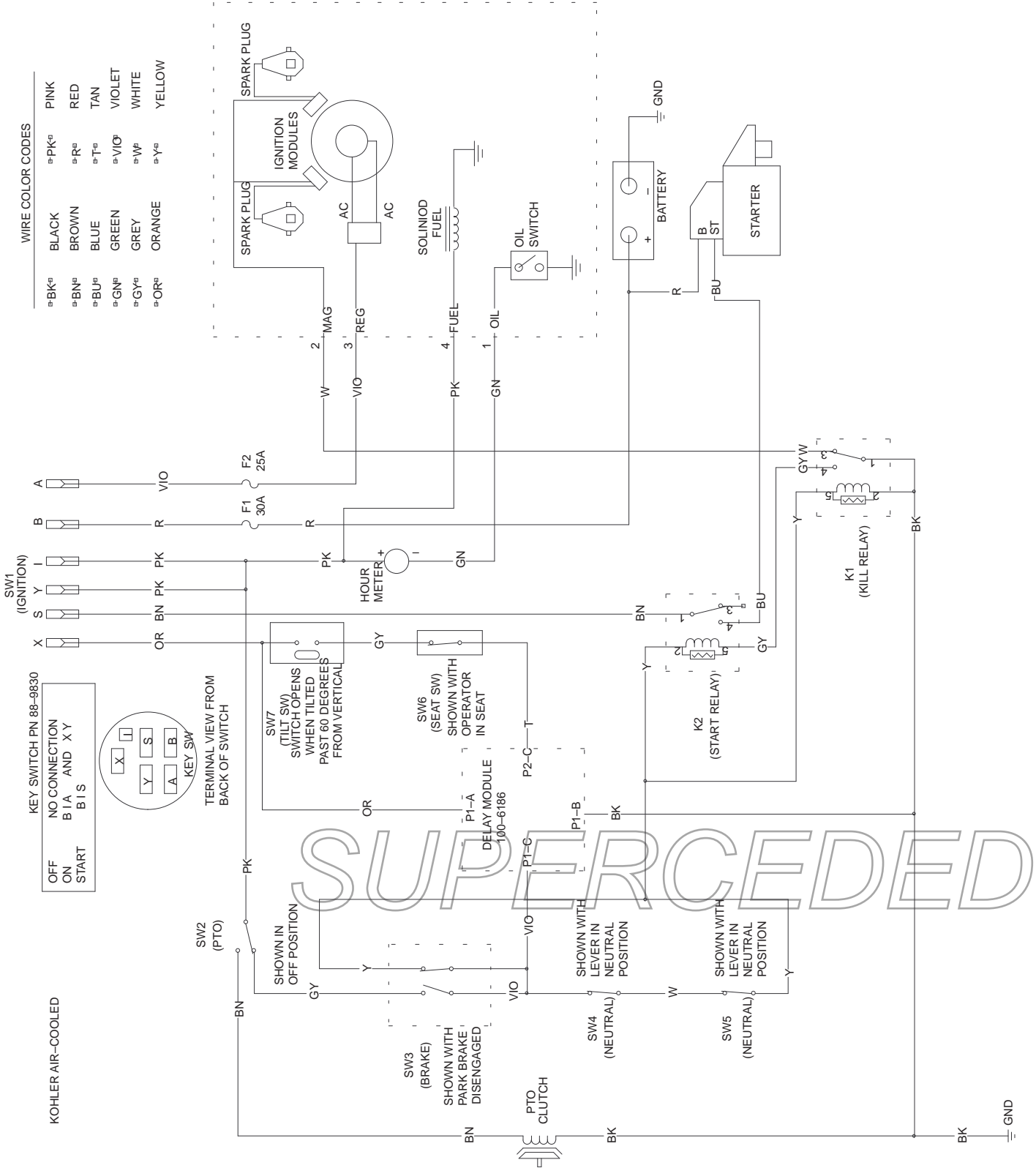

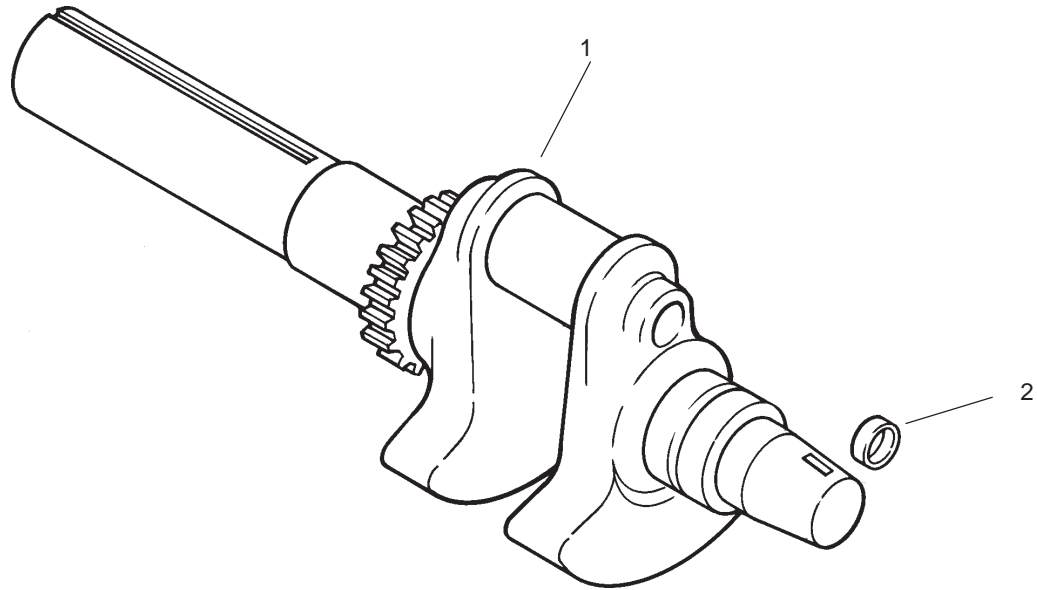

### Group 1 – Crankshaft Assembly Kohler CH740-0007

Ref. No.	Part No.	Qty.	Description	Ref. No.	Part No.	Qty.	Description
1	24 014 06-S	1	Crankshaft (Includes 2)				
2	52 139 09-S	1	Plug, cup				

SUPERCEDED

Obtain Parts from Kohler

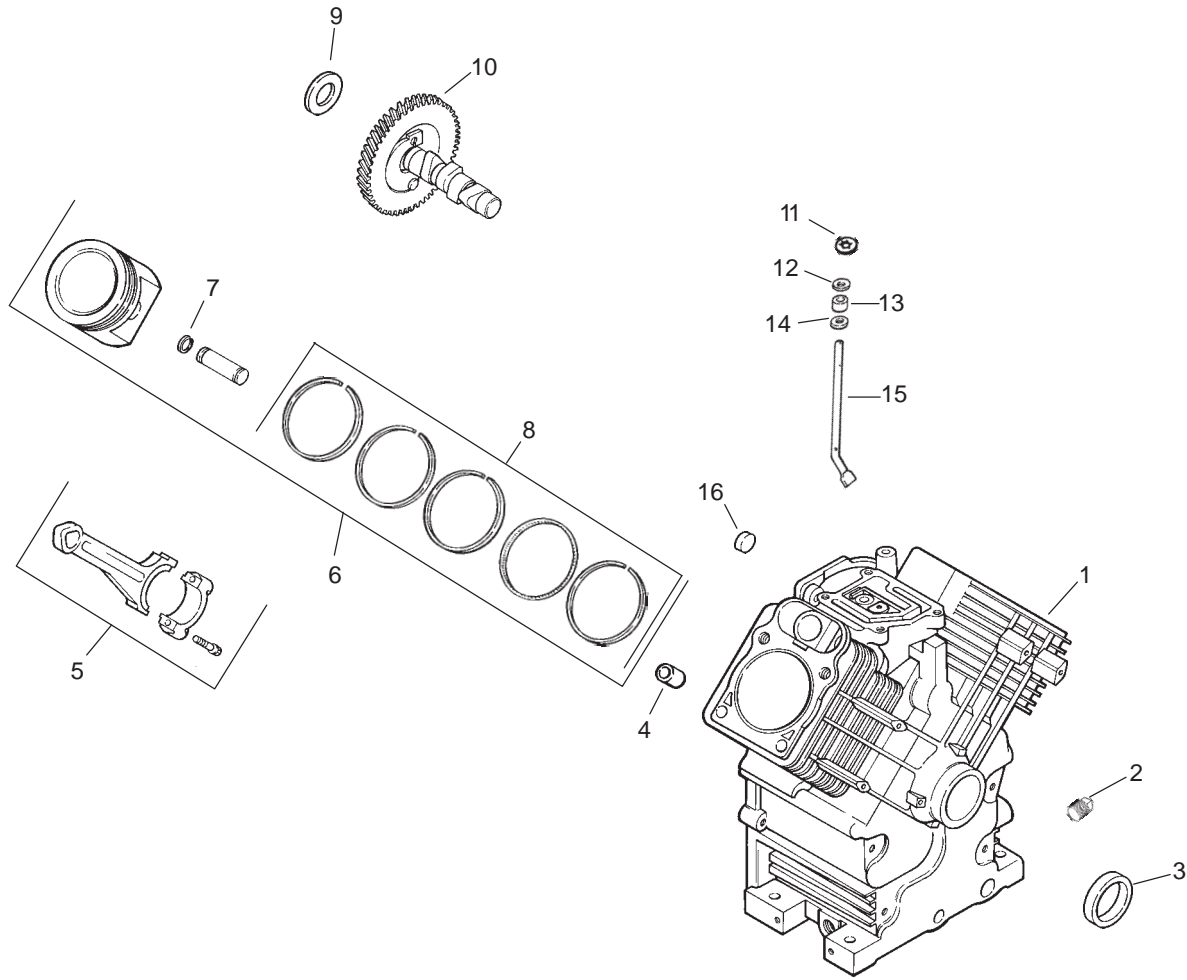

## Group 2 – Crankcase Assembly Kohler CH740-0007

Ref. No.	Part No.	Qty.	Description
1	N/A	1	Crankcase (Use Short Block or Miniblock)
2	25 139 57-S	2	Plug, sq. hd. 3/8" N.P.T.F. (2)
3	24 032 01-S	1	Seal, oil front
4	24 380 13-S	6	Pin, locating
5	24 067 13-S	2	Connecting Rod (Std.)
	24 067 14-S	2	Connecting Rod (.25)
6	24 874 08-S	2	Piston w/Ring Set (Std.) (Includes 7,8)
	24 874 16-S	2	Piston w/Ring Set (.08)
7	24 018 01-S	4	Retainer, piston pin
8	24 108 04-S	2	Ring Set (Std. & .08)
9	12 422 09-S	1	Shim, camshaft (A.R.) red
	12 422 13-S	1	Shim, camshaft (A.R.) black
	12 422 07-S	1	Shim, camshaft (A.R.) white
	12 422 08-S	1	Shim, camshaft (A.R.) blue
	12 422 10-S	1	Shim, camshaft – yellow

Ref. No.	Part No.	Qty.	Description
	12 422 11-S	1	Shim, camshaft (A.R.) green
	12 422 12-S	1	Shim, camshaft (A.R.) gray
10	24 012 18-S	1	Camshaft
11	24 018 09-S	1	Retainer, ring
12	M-931010-S	1	Washer, plain 9 mm
13	28 032 09-S	1	Seal, governor cross shaft
14	24 468 15-S	1	Washer, flat 1/4"
15	24 144 38-S	1	Shaft, governor cross
16	52 139 09-S	1	Plug, cup

Obtain Parts from Kohler

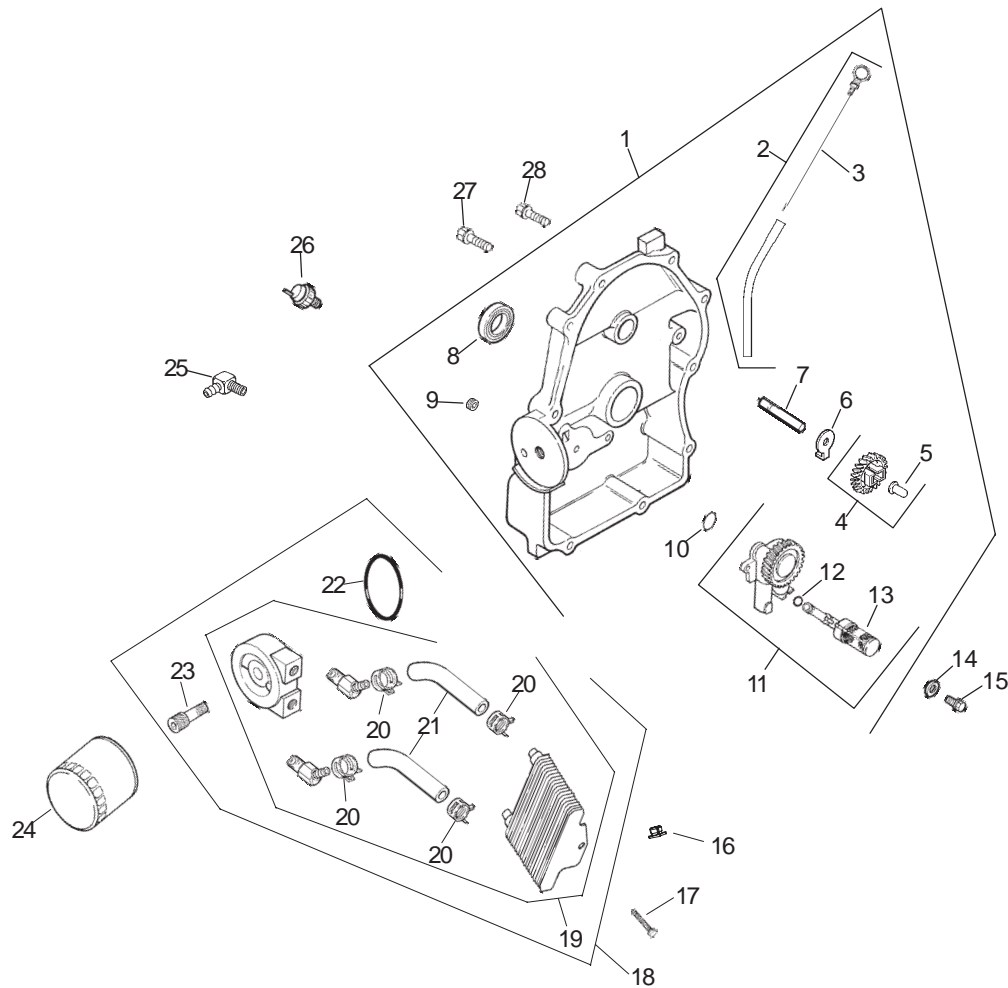

### Group 3 – Oil Pan/Lubrication Assembly Kohler CH740-0007

Ref. No.	Part No.	Qty.	Description	Ref. No.	Part No.	Qty.	Description
1	24 009 83-S	1	Plate, closure assembly (Includes 2-13)	17	25 086 49-S	2	Screw, tapping 1/4-10x3/4
2	24 755 121-S	1	Tube assembly, dipstick (Includes 3)	18	54 755 21-S	1	Kit, oil cooler (Includes 19-23)
3	24 038 10-S	1	Dipstick	19	24 594 09-S	1	Cooler assembly, oil (Includes 20,21)
4	24 043 12-S	1	Kit, governor gear (Includes 5)	20	24 237 10-S	4	Clamp, oil cooler hose
5	12 380 01-S	1	Pin, governor regulating	21	24 326 15-S	2	Hose, oil cooler
6	52 448 02-S	1	Tab, locking	22	24 153 13-S	1	O-Ring
7	12 144 02-S	1	Shaft, governor gear	23	28 136 01-S	1	Nipple, oil filter
8	52 032 08-S	1	Seal, oil (PTO end)	24	52 050 02-S	1	Filter, oil
9	25 139 60-S	1	Plug, pipe hex. ctsk. 1/8"	25	25 155 02-S	1	Connector
10	24 153 08-S	1	O-Ring	26	24 099 03-S	1	Switch, pressure
11	24 393 10-S	1	Oil pump assembly (Includes 12,13)	27	24 086 16-S	9	Screw, hex. flange M8x1.25x45
12	24 153 01-S	1	O-Ring, oil pick-up	28	24 086 17-S	1	Screw, hex. flange M8x1.25x45
13	24 381 04-S	1	Pick-up, oil	*	24 113 25-S	1	Decal, oil cooler
14	M-631005-S	2	Washer, plain 6 mm				
15	M-645025-S	2	Screw, hex. flange M6x1.0x25				
16	24 100 01-S	2	Nut, plastic				

Obtain Parts from Kohler

\* Not Illustrated

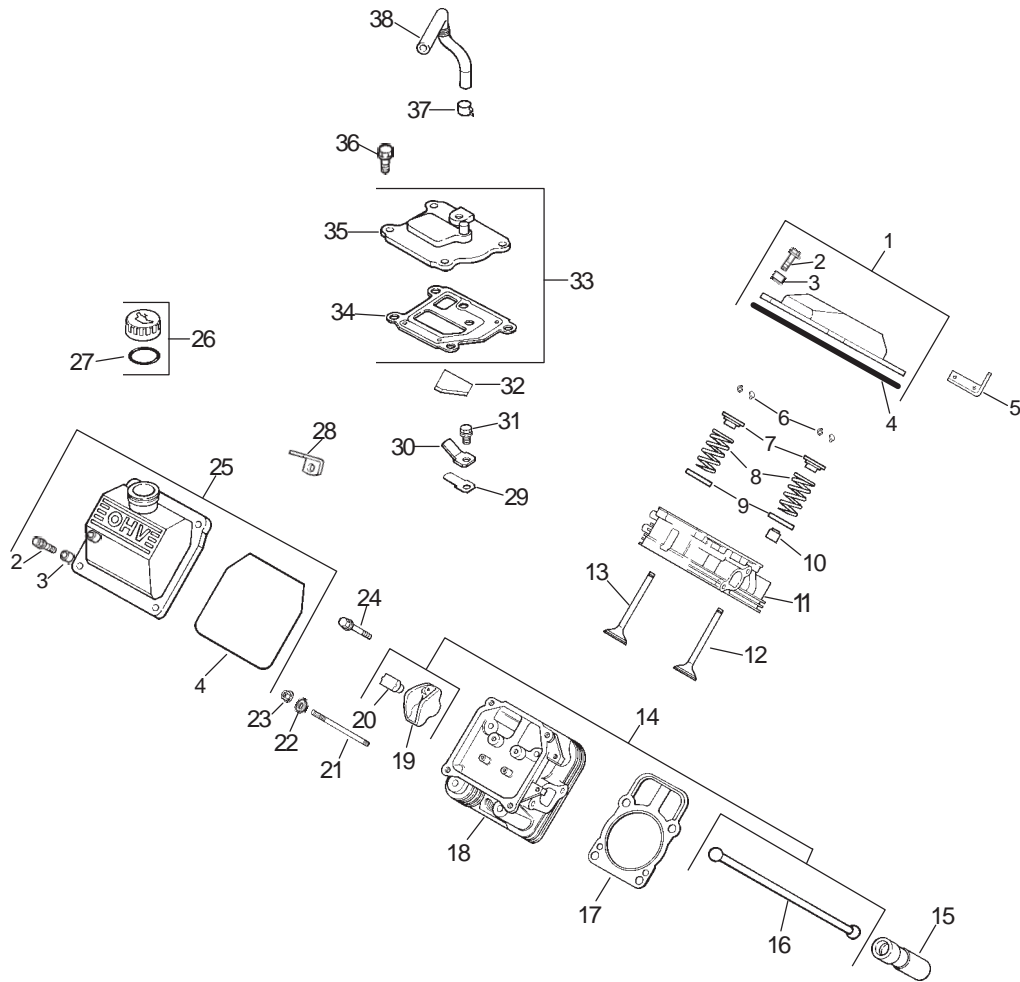

## Group 4 – Head/Valve/Breather Assembly Kohler CH740-0007

Ref. No.	Part No.	Qty.	Description
1	24 755 74-S	1	Kit, valve cover-plain (Includes 2-4)
2	M-651030-S	4	Screw, hex. flange M6x1.0x30
3	24 112 08-S	4	Spacer
4	24 153 23-S	1	O-Ring, valve cover
5	24 445 01-S	1	Strap, lifting
6	12 755 03-S	4	Kit, retainer
7	12 173 01-S	4	Cap, valve spring
8	24 089 02-S	4	Spring, valve
9	235011-S	4	Retainer, spring
10	66 032 05-S	2	Seal, valve stem
11	24 318 65-S	1	Head assembly, #1 cylinder
12	24 017 01-S	2	Valve, intake (Std.)
	24 017 02-S	2	Valve, intake (.25)
13	24 016 01-S	2	Valve, exhaust (Std.)
	24 016 02-S	2	Valve, exhaust (.25)
14	24 755 66-S	1	Kit, valve train (Includes 16,19,20)
15	25 351 01-S	4	Lifter, valve
16	24 411 05-S	4	Rod, push
17	24 041 37-S	2	Gasket, cylinder head

Ref. No.	Part No.	Qty.	Description
18	24 318 66-S	1	Head assembly, #2 cylinder
19	25 186 01-S	4	Arm, rocker
20	24 599 01-S	4	Pivot, rocker arm
21	24 072 09-S	8	Stud, cylinder head M8x1.25x20, 105 mm long
22	24 468 16-S	8	Washer, flat 8 mm
23	24 100 10-S	8	Nut, hex. flange M8x1.25
24	M-640034-S	4	Screw, hex. flange M6x1.0x34
25	24 755 75-S	1	Kit, valve cover-oil fill (Includes 2-4)
26	24 755 46-S	1	Kit, oil fill cap (Includes 27)
27	25 153 02-S	1	O-Ring
28	12 445 05-S	1	Strap, lifting
29	24 402 03-S	1	Reed, breather
30	12 018 01-S	1	Retainer, breather reed
31	M-545010-S	1	Screw, hex. flange M5x0.8x10
32	24 050 01-S	1	Filter, breather

Obtain Parts from Kohler

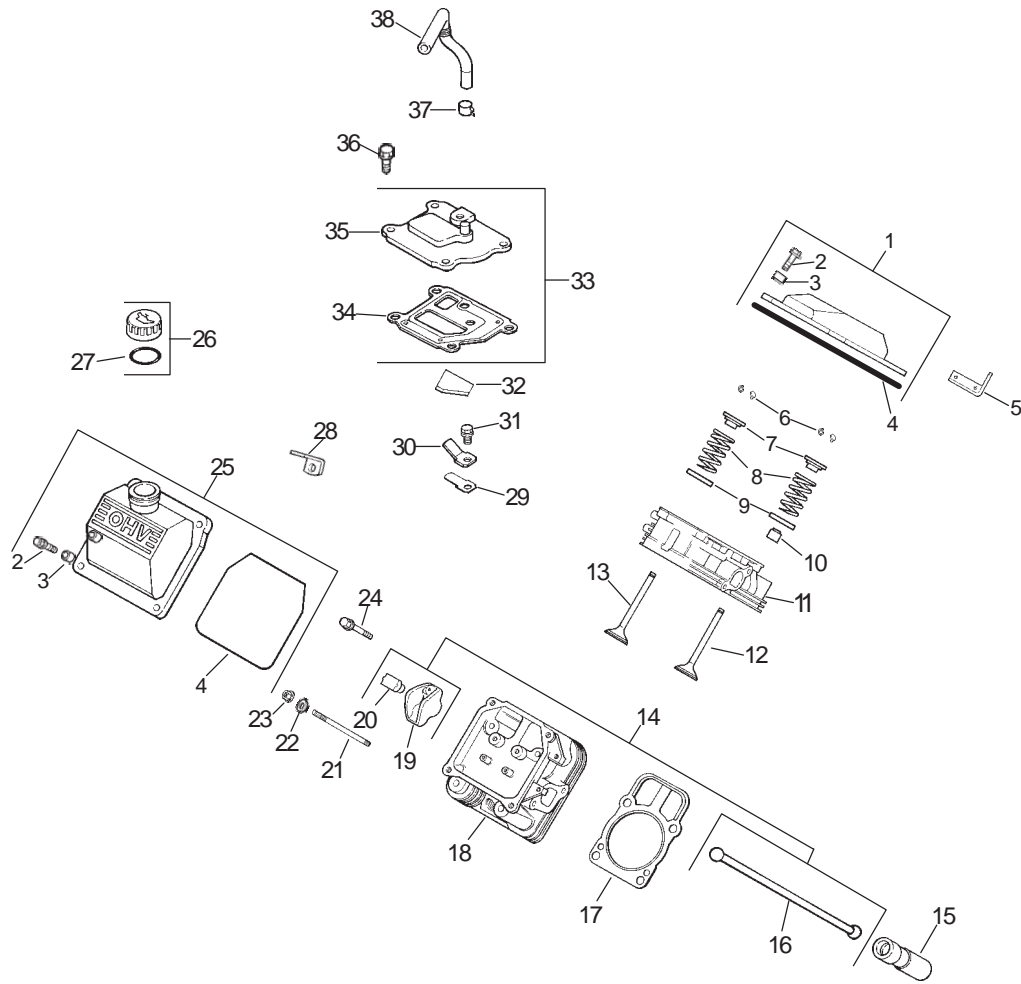

### Group 4 – Head/Valve/Breather Assembly (Continued) Kohler CH740-0007

Ref. No.	Part No.	Qty.	Description	Ref. No.	Part No.	Qty.	Description
33	24 033 01-S	1	Kit, breather (Includes 34,35)				
34	24 041 23-S	1	Gasket, breather				
35	24 096 86-S	1	Cover, breather				
36	M-645020-S	4	Screw, hex. flange M6x1.0x20				
37	25 237 08-S	2	Clamp, breather				
38	24 326 31-S	1	Hose, breather				

SUPERCEDED

Obtain Parts from Kohler

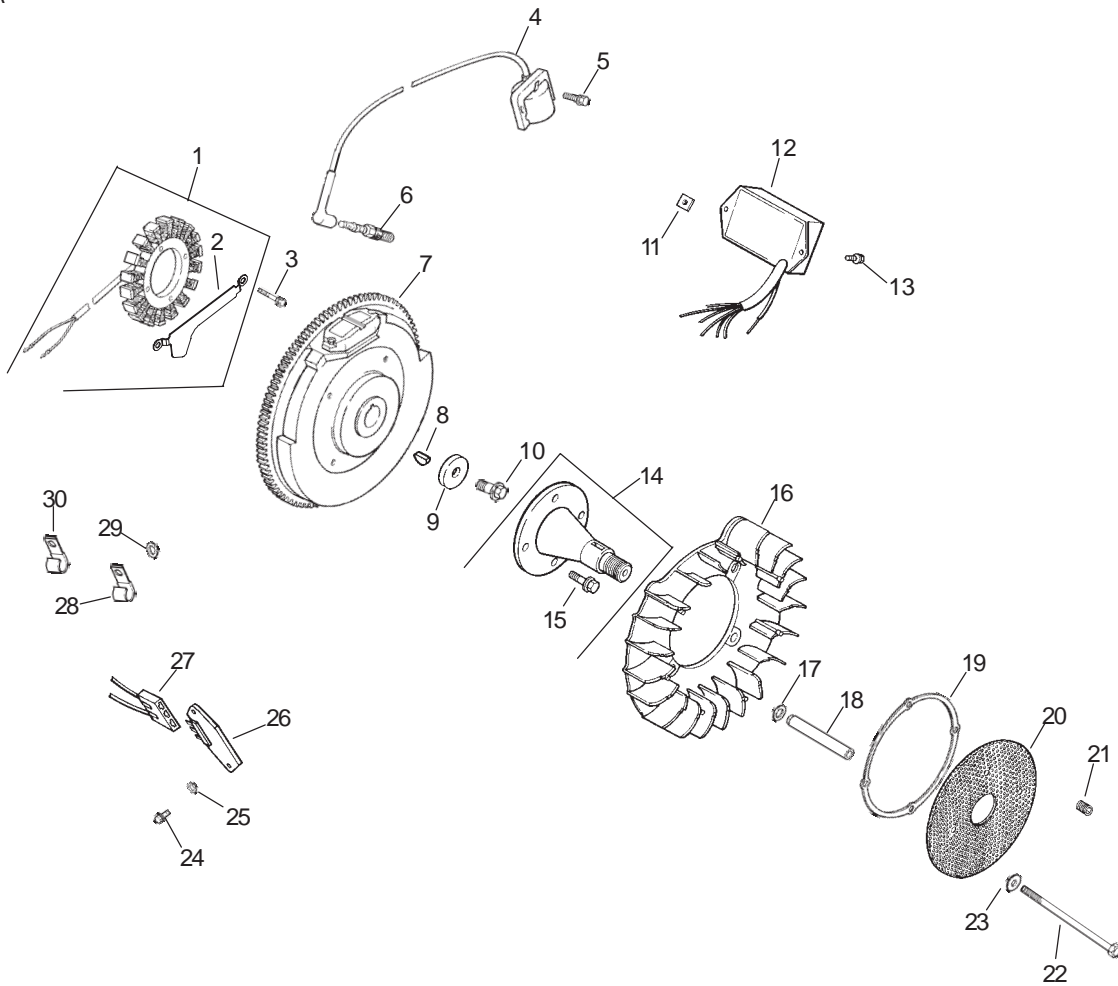

## Group 5 – Ignition/Electrical Assembly Kohler CH740-0007

Ref. No.	Part No.	Qty.	Description
1	54 755 09-S	1	Kit, stator (Includes 2)
2	24 126 71-S	1	Bracket, stator wire
3	M-548025-S	2	Screw, hex. cap M5x0.8x25
4	24 584 15-S	2	Module, ignition
5	M-561025-S	4	Screw, thread forming M5x0.8x16
6	12 132 06-S	2	Spark Plug
7	24 025 25-S	1	Flywheel
8	X-42-15-S	1	Key
9	12 468 03-S	1	Washer, plain 3/8"
10	12 086 14-S	1	Screw, hex. flange M10x1.5x46
11	24 100 02-S	2	Nut, plastic
12	24 584 27-S	1	Module, spark advance
13	24 086 41-S	2	Screw, phillips hd. 11-16x1/2"
14	24 755 08-S	1	Kit, front drive shaft (Includes 15)
15	M-839025-S	4	Screw, hex. flange M8x1.25x25
16	24 157 07-S	1	Fan
17	24 468 11-S	4	Washer, spring
18	24 112 14-S	4	Spacer, grass screen

Ref. No.	Part No.	Qty.	Description
19	24 141 06-S	1	Ring, support
20	24 162 22-S	1	Screen, grass
21	25 086 43-S	1	Screw, set
22	M-603100-S	4	Screw, hex. cap M6x1.0x100
23	X-25-53-S	4	Washer, plain 1/4"
24	24 086 18-S	2	Screw, phillips hd. 11-16x7/8
25	X-25-92-S	2	Washer, plain 3/16"
26	25 403 03-S	1	Rectifier-regulator 15 amp
27	236602-S	1	Connector (3 contact)
28	47 154 01-S	1	Clip, cable
29	X-25-63-S	1	Washer, plain 1/4"
30	48 154 02-S	1	Clip, cable
*	24 518 12-S	1	Lead, black, (5" – 12 gauge – insulated grip barrel eyelet terminals)
*	X-22-11-S	1	Washer, lock 1/4" (for ground screw & wire)
*	24 176 98-S	1	Harness, wiring
*	25 454 03-S	2	Tie, cable

Obtain Parts from Kohler

\* Not Illustrated

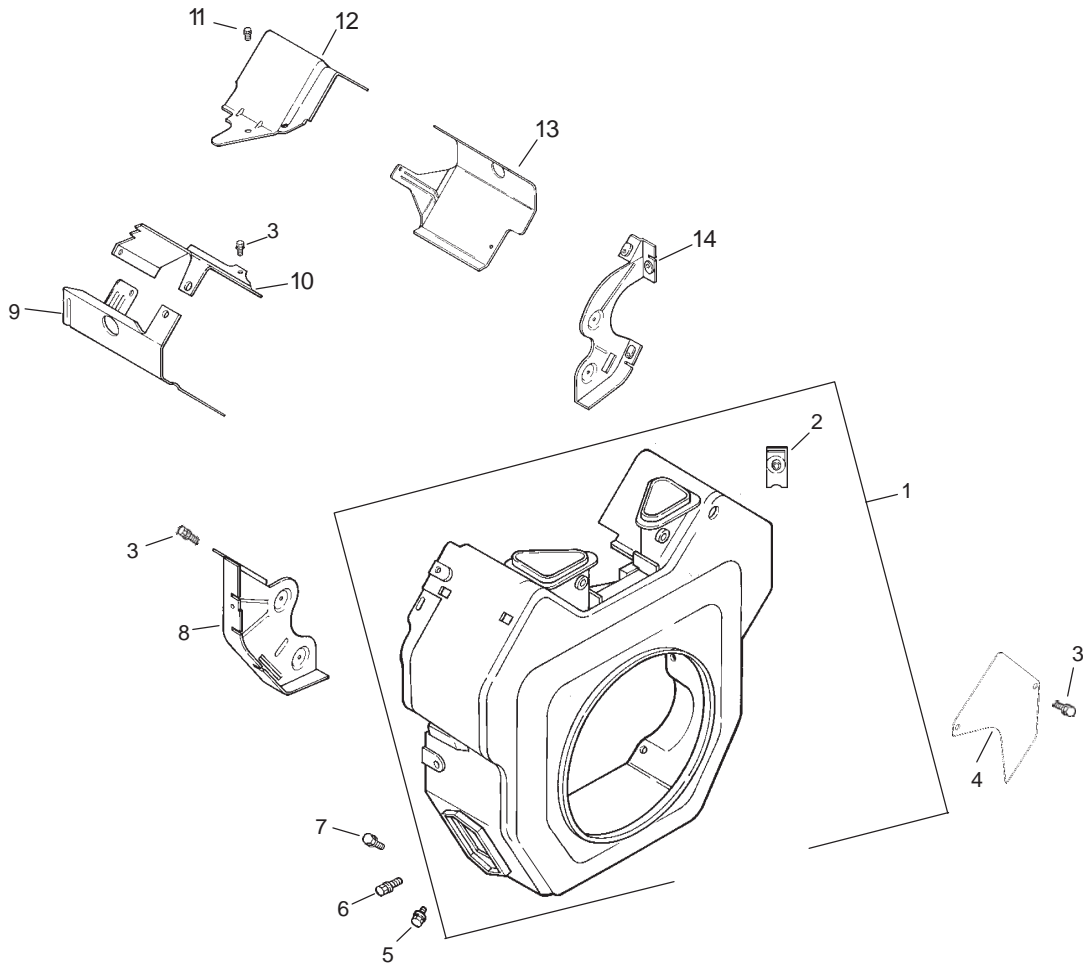

## Group 6 – Blower Housing Assembly Kohler CH740-0007

Ref. No.	Part No.	Qty.	Description	Ref. No.	Part No.	Qty.	Description
1	84 027 13-S	1	Housing, blower (Includes 2)	14	24 146 20-S	1	Plate, backing – #1 side
2	25 154 02-S	4	Clip	*	24 113 124-S	1	Decal, 27 HP
3	M-645016-S	10	Screw, hex. flange M6x1.0x16				
4	24 096 63-S	2	Cover, access				
5	M-551016-S	1	Screw, hex. flange M5x0.8x16				
6	M-545016-S	2	Screw, hex. flange M5x0.8x16				
7	M-545020-S	4	Screw, hex. flange M5x0.8x20				
8	24 146 19-S	1	Plate, backing – #2 side				
9	24 063 39-S	1	Baffle, cylinder barrel-#2 side				
10	24 063 17-S	1	Baffle, valley – #2 side				
11	M-545010-S	2	Screw, hex. flange M5x0.8x10				
12	24 063 59-S	1	Baffle, valley – #1 side				
13	24 063 58-S	1	Baffle, cylinder barrel-#1 side				

Obtain Parts from Kohler

\* Not Illustrated

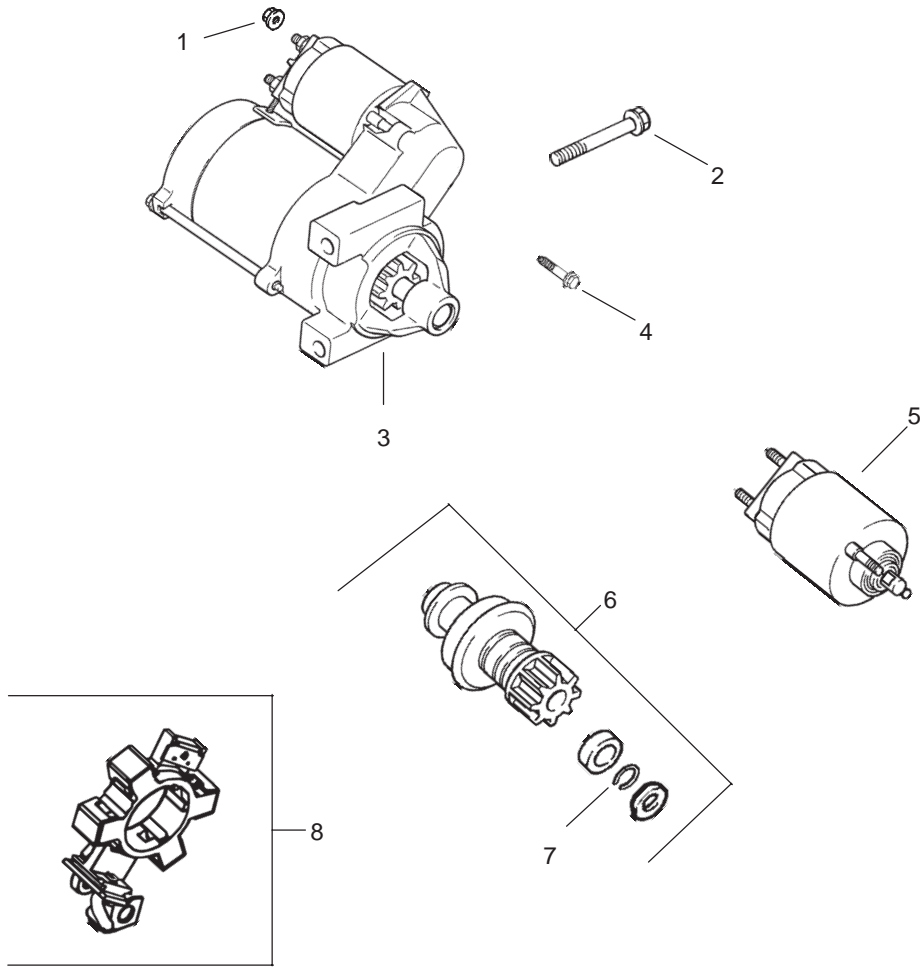

### Group 7 – Starter Assembly Kohler CH740-0007

Ref. No.	Part No.	Qty.	Description
1	M-841080-S	1	Nut, hex flange M8x1.25
2	M-839080-S	2	Screw, hex. flange M8x1.25x80
3	25 098 09-S	1	Starter, solenoid shift assembly (Includes 4-8)
4	25 086 113-S	3	Screw, external Torx head
5	25 435 05-S	1	Kit, solenoid (Includes 4)
6	25 755 33-S	1	Kit, pinion drive (Includes 7)
7	25 141 05-S	1	Ring
8	25 225 01-S	1	Kit, brush

Ref. No.	Part No.	Qty.	Description

Obtain Parts from Kohler

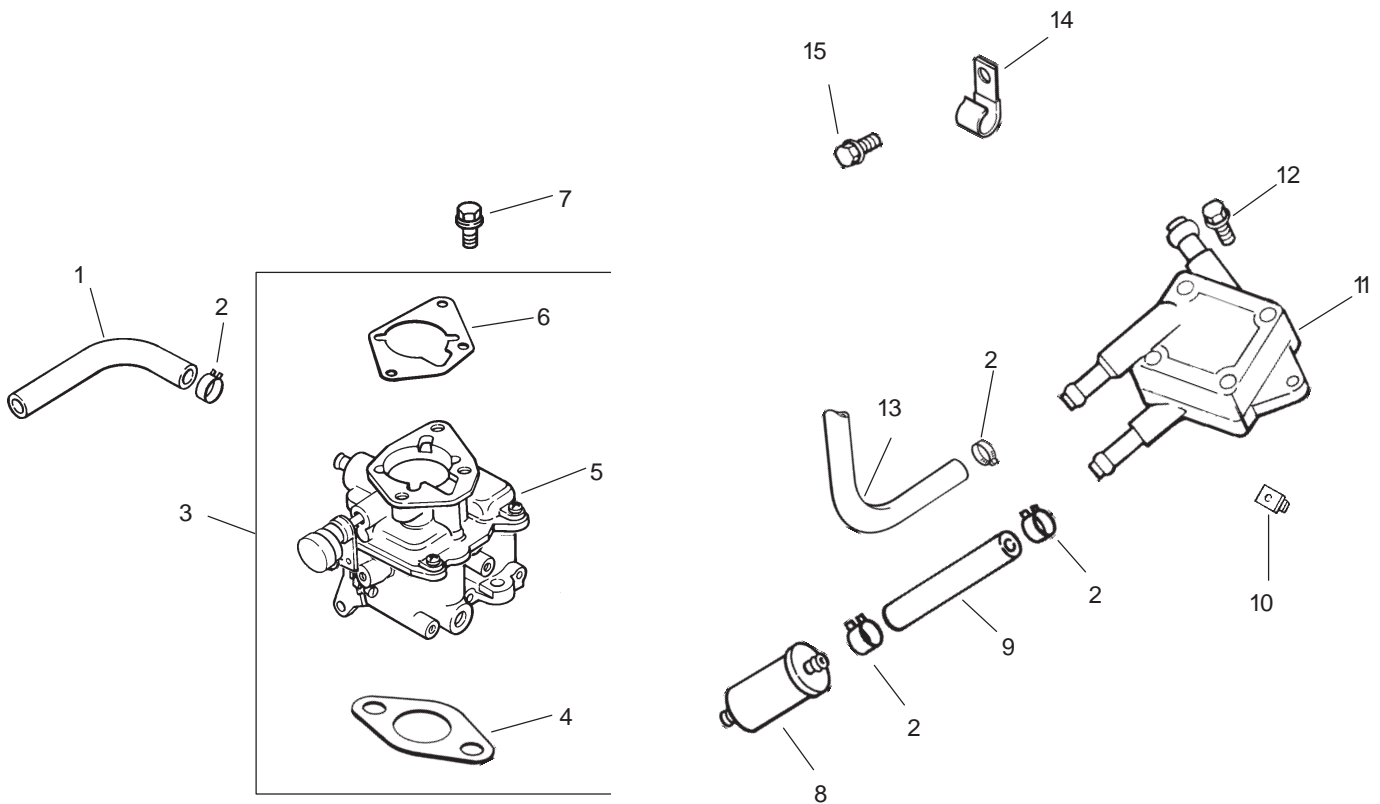

## Group 8 – Fuel System Assembly Kohler CH740-0007

Ref. No.	Part No.	Qty.	Description	Ref. No.	Part No.	Qty.	Description
1	25 353 32-S	1	Line, fuel 9-1/4"	12	24 086 12-S	2	Screw, hex. cap M6x1.7x18
2	25 237 14-S	6	Clamp, hose	13	24 353 02-S	1	Line, fuel 15"
3	24 853 93-S	1	Kit, carburetor w/gasket (Includes 4-6)	14	47 154 01-S	1	Clip, cable
4	24 041 17-S	1	Gasket, carburetor	15	M-650012-S	1	Screw, hex. flange M6x1.0x12
5	24 053 93	1	Carburetor assembly (For information only, not available separately) (Service with kits 24 757 01-S, 24 757 02-S, 24 757 03-S, 24 757 07-S, 24 757 08-S, and 24 757 09-S)	*	24 757 01-S	1	Kit, solenoid
6	24 041 06-S	1	Gasket, air cleaner base	*	24 757 02-S	1	Kit, float repair
7	M-651030-S	2	Screw, hex. flange	*	24 757 03-S	1	Kit, carburetor repair
8	24 050 02-S	1	Filter, fuel	*	24 757 07-S	1	Kit, choke repair
9	25 353 15-S	1	Line, fuel 3-1/2"	*	24 757 08-S	1	Kit, accelerator pump diaphragm repair
10	24 100 01-S	2	Nut, plastic	*	24 757 09-S	1	Kit, accelerator pump seal and bushing kit
11	24 393 16-S	1	Pump, fuel				

Obtain Parts from Kohler

\* Not Illustrated

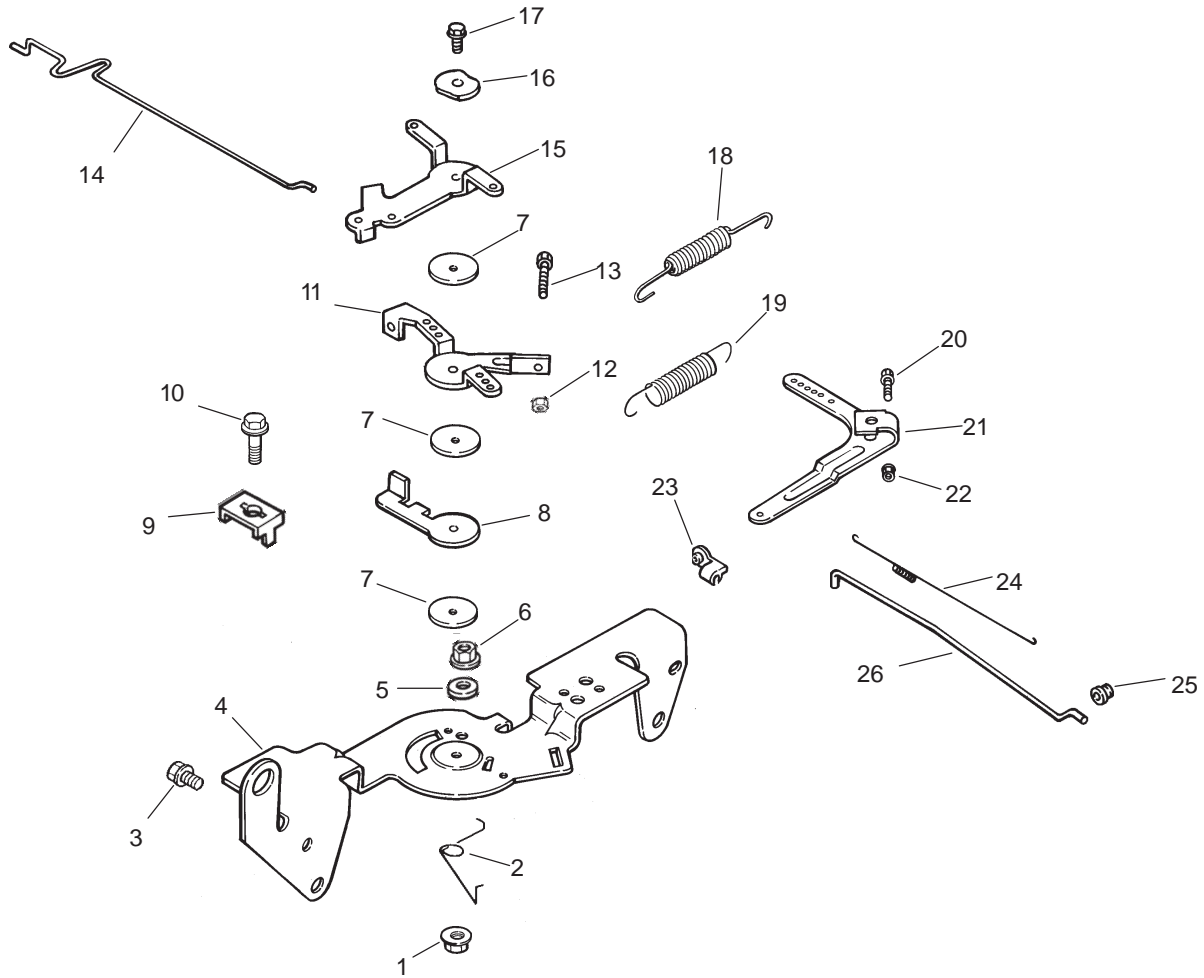

## Group 9 – Engine Control Assembly Kohler CH740-0007

Ref. No.	Part No.	Qty.	Description
1	M-547050-S	1	Nut, hex. lock M5x0.8
2	24 089 03-S	1	Spring, choke return
3	M-645016-S	4	Screw, hex. flange M6x1.0x16
4	24 126 56-S	1	Bracket, control
5	X-20-1-S	1	Washer, lock 1/4
6	M-541050-S	1	Nut, hex. flange M5x0.8
7	24 468 01-S	3	Washer, plain 1/4
8	24 090 07-S	1	Lever, throttle actuator
9	12 237 01-S	2	Clamp, cable
10	M-545016-S	3	Screw hex. flange M5x0.8x16
11	24 090 03-S	1	Lever, throttle control
12	M-446030-S	1	Nut, hex. flange M4x0.7
13	M-401030-S	1	Screw, hex. flange M4x0.7x30
14	24 079 21-S	1	Linkage, choke
15	24 090 05-S	1	Lever, choke
16	41 468 03-S	1	Washer, spring 1/4
17	M-545020-S	1	Screw, hex. flange M5x0.8x20
18	24 089 51-S	1	Spring, throttle limiter

Ref. No.	Part No.	Qty.	Description
19	24 089 46-S	1	Spring, governor
20	24 211 03-S	1	Bolt, rd. hd. sq. neck M6x1.0x25
21	24 090 33-S	1	Lever, governor
22	M-641060-S	1	Nut, hex. flange M6x1.0
23	25 158 11-S	1	Bushing, linkage retaining
24	24 089 01-S	1	Spring, linkage
25	25 158 08-S	1	Bushing, throttle linkage
26	24 079 01-S	1	Linkage, throttle

Obtain Parts from Kohler

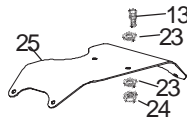
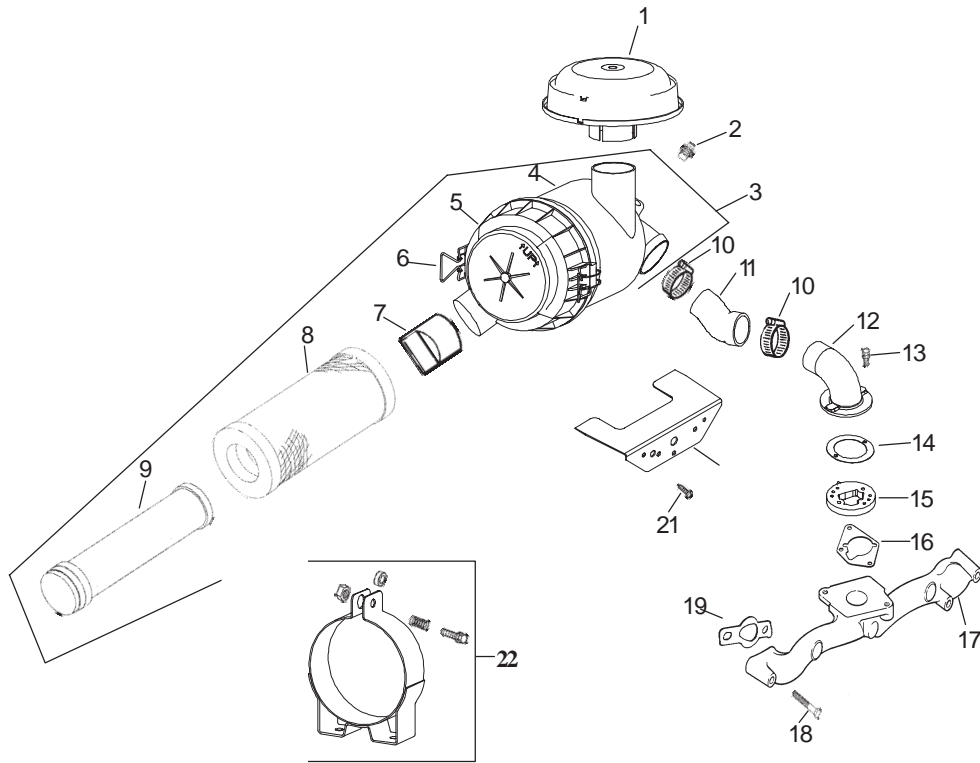

## Group 10 – Air Intake/Filtration Assembly Kohler CH740-0007

Ref. No.	Part No.	Qty.	Description	Ref. No.	Part No.	Qty.	Description
1	25 324 02-S	1	Hood, air cleaner	18	25 086 84-S	4	Screw, hex. flange M6x1.0x55
2	25 139 20-S	1	Plug, pipe	19	24 041 01-S	2	Gasket, intake manifold
3	25 048 07-S	1	Cleaner, heavy duty air (Includes 4-9)	20	24 314 25-S	1	Shield, debris
4	25 081 01-S	1	Housing, heavy duty air cleaner	21	24 086 06-S	2	Screw, phillips hd. 11-16x3/4"
5	25 096 06-S	1	Cover, heavy duty air cleaner	22	25 126 02-S	1	Bracket, air cleaner
6	25 154 05-S	2	Clip	23	X-25-73-S	4	Washer, plain 1/4"
7	24 462 07-S	1	Valve, dust ejector	24	M-647060-S	2	Nut, hex. lock M6x0.8
8	25 083 01-S	1	Element – primary	25	24 126 98-S	1	Bracket, air cleaner
9	25 083 04-S	1	Element safety filter				
10	25 237 07-S	2	Clamp, hose				
11	24 326 32-S	1	Hose, air cleaner				
12	24 029 21-S	1	Adapter, remote air cleaner				
13	M-639016-S	6	Screw, hex. flange M6x1.0x16				
14	24 041 34-S	1	Gasket, adapter				
15	24 029 26-S	1	Adapter				
16	24 041 06-S	1	Gasket, air cleaner base				
17	24 164 14-S	1	Manifold, intake				

Obtain Parts from Kohler

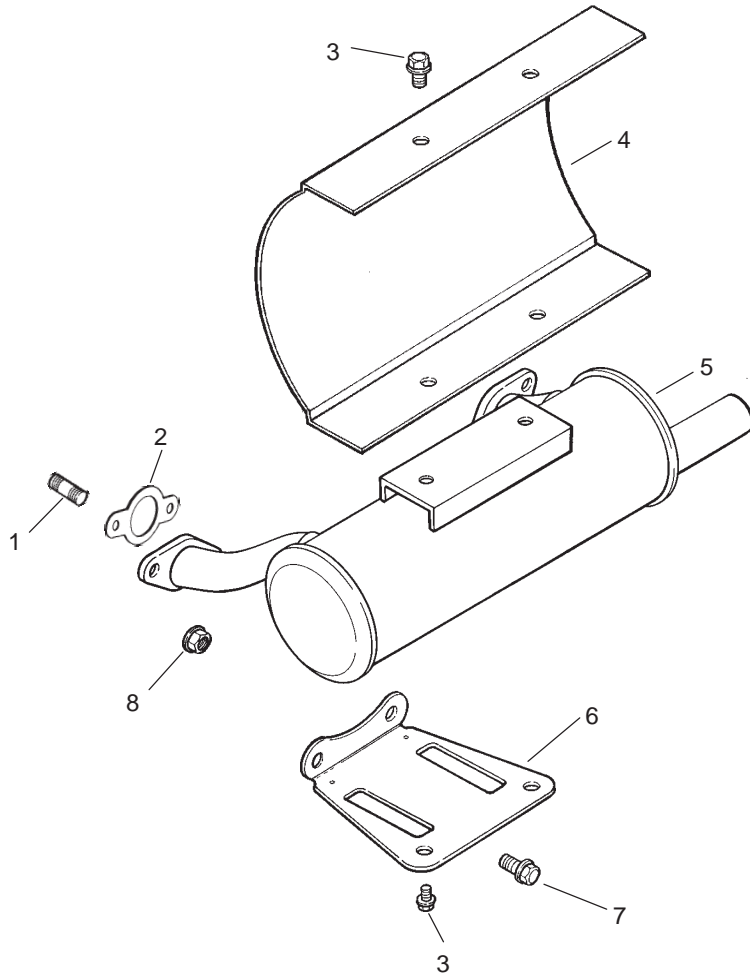

### Group 11 – Exhaust Assembly Kohler CH740-0007

Ref. No.	Part No.	Qty.	Description	Ref. No.	Part No.	Qty.	Description
1	25 072 04-S	4	Stud M8x1.25x33				
2	24 041 49-S	2	Gasket, exhaust				
3	M-650012-S	4	Screw, hex. flange M6x1.0x12				
4	24 314 04-S	1	Shield, heat				
5	24 068 18-S	1	Muffler, canister oil filter outlet				
6	24 126 12-S	1	Bracket, muffler				
7	M-839020-S	2	Screw, hex. flange M8x1.25x20				
8	M-841080-S	4	Nut, hex. flange M8x1.25				
*	24 755 113-S		Gasket Set				

Obtain Parts from Kohler

\* Not Illustrated









*SUPERCEDED*