



MODEL NO. 41134-220000101 & UP

OPERATOR'S,
SET-UP & PARTS
MANUALHOSE REEL KIT and HAND SPRAYER KIT
for the MULTI-PRO™ 1200 and 1250

To assure maximum safety, optimum performance, and to gain knowledge of the product, it is essential that you or any other operator of this equipment read and understand the contents of this manual before the vehicle engine is ever started. Pay particular attention to the SAFETY INSTRUCTIONS highlighted by this symbol—

 The safety alert symbol means CAUTION, WARNING, or DANGER — personal safety instruction. Failure to comply with the instruction may result in personal injury.

SAFETY INSTRUCTIONS

It is very important that all persons operating this equipment have easy access to these instructions at all times.

RECOGNIZE SAFETY INFORMATION

 This safety-alert symbol calls attention to a **dangerous** situation, which could result in serious injury or death to the operator or a bystander.

Safety, mechanical and some general information in this manual are emphasized. **DANGER, WARNING** and **CAUTION** identify safety messages. Whenever the triangular safety symbol appears, it is followed by a safety message that must be read and understood. For more details concerning safety, read the Safety Instructions that follow. **IMPORTANT** identifies special mechanical information and **NOTE** identifies general information worthy of special attention.

These instructions are provided as a guide for the safe operation and maintenance of this equipment. However, the operator's personal safety, as well as those persons in the work area, will depend on the careful actions and good judgement of the operator.

To reduce the potential for injury or death, comply with the following safety instructions.

BEFORE OPERATING:

1. Operate this attachment only after reading and understanding the contents of this manual. A replacement manual is available by sending complete model and serial number to: Hahn, Inc., 1625 N. Garvin, Evansville, IN. 47711.

2. Learn how to operate the Hand Sprayer Kit and how to use the controls properly. **DO NOT** let anyone operate this equipment without first receiving thorough instructions.

3. Chemicals can injure persons, animals, plants, soils or other property. To eliminate environmental damage and personal injury:

A. Obtain proper training before using or handling chemicals.

B. Select the proper chemical for the job.

C. Follow manufacturer's instructions on chemical container labels. Apply and handle chemicals as recommended.

D. Handle and apply chemicals with care. Wear goggles and other necessary protective equipment. Handle chemicals in well ventilated areas. Never smoke while handling chemicals.

E. Properly dispose of chemical container and unused chemicals.

4. **DO NOT** aim Hand Sprayer at any person or any animal. Fluids under high pressure can penetrate the human skin and can cause severe injury, possibly resulting in amputation or death. Hot liquids and chemicals can also cause burns or injury. If any part of the body comes in contact with the spray stream, immediately consult a physician.

5. **DO NOT** at any time place hand or any other part of the body in front of spray nozzle or tip.

SAFETY INSTRUCTIONS

6. **DO NOT** leave equipment under pressure unattended at any time. Relieve line pressure by shutting off power to pump, turning off the liquid supply to the pump, and actuating trigger until all fluid ceases to flow; then position trigger lock to the "locked off" position.
7. **DO NOT** use damaged, perforated, or weakened fluid hose.
8. **DO NOT** use a Hand Sprayer with a damaged trigger lock.
9. **DO NOT** operate a Hand Sprayer if there are any leaks from the packings, fitting, hoses, etc. Fluids which are under high pressure can penetrate skin, clothing, etc. and cause serious injury.
10. **DO NOT** spray near power lines, since contact could result in severe electrical shock.
11. **DO NOT** handle a Hand Sprayer without a tip or nozzle any differently than one with a tip or nozzle. Even with the tip or nozzle removed, the

spray Hand Sprayer discharge a large volume of liquid at a high velocity.

12. To be sure of optimum performance and safety, always purchase genuine TORO replacement parts and accessories. Replacement parts and accessories made by other manufacturers could be dangerous. Altering the Hand Sprayer in any manner may affect the Hand Sprayer's operation, performance, durability or its use may result in injury or death. Such use could void the product warranty of the Toro Company.

13. This accessory should not be modified without the Toro Company's authorization. Direct any inquiries to:

The Toro Company
Commercial Division
Hahn, Inc.
1625 N. Garvin
Evansville, IN 47711

OPERATION

1. Make sure pump is in the disengaged position and there is no pressure in any part of the system. Examine all connections, making sure they are of the proper type and are secure.

3. Make sure trigger lock is in "locked off" position. Do not turn on the pump or operate spray Hand Sprayer if trigger lock is not operating properly.

4. If spraying in cold weather, be sure to protect the Hand Sprayer from freezing.

5. Operation of this Hand Sprayer in windy conditions will cause premature breakup of liquid stream.

6. Flush Hand Sprayer after each spray period, using the same safety precautions as used during spraying operations. Always use the lowest possible pressure for flushing.

7. Wear rubber gloves and a full body protective suit, including safety glasses, when operating the Hand Sprayer.



WARNING

Fluids under high pressure can penetrate the human skin and can cause severe injury, possibly resulting in amputation or death.

- Hot liquids and chemicals can also cause burns or injury.
- **DO NOT** at any time place hand or any other part of the body in front of spray nozzle or tip.
- **DO NOT** aim Hand Sprayer at any person or any animal.
- If any part of the body comes in contact with the spray stream, immediately consult a physician.

2. Before engaging the pump and holding the Hand Sprayer in downward vertical position pointed away from body, familiarize yourself with the operation of the trigger lock.



WARNING

DRIVING WHILE USING THE HAND SPRAYER CAN CAUSE LOSS OF CONTROL OF VEHICLE, RESULTING IN SEVERE INJURY OR DEATH.

DO NOT OPERATE HAND SPRAYER WHILE DRIVING.

SET-UP

Refer to the illustrated Parts List for the details of parts used in assembling the Hose Reel Kit.

“Right” and “Left” as used in the following instructions, refer to the operator’s right and left when seated in the normal operating position. Likewise, “Front” and “Rear” as seen from the operator’s position.

FRAME ASSEMBLY:

1. Disconnect negative battery terminal from the Battery.

2. Loosen the two (2) 1/2" x 18 screws securing the Boom Mounting Assembly to the Vehicle Frame. Slide the Boom Mount Assembly out 2" inches to allow installation of the Hose Reel Mounting Brackets.

3. Insert the right Hose Reel Mounting Bracket with the Hand Sprayer holder between the Boom and Tank. The Bracket should be pointed with the open end toward the left side of Vehicle, and then turn the open end toward the front of Vehicle. Secure to frame of Vehicle with two (2) u-bolts and four (4) nuts. Install Tube Cap in the upper Tube of the Mounting Bracket. See Illustration on page 12.

4. Insert the remaining left Hose Reel Mounting Bracket between the Boom and Tank. The Bracket should be pointed with the open end toward the right side of the Vehicle and then turn the open end toward the front of the Vehicle. Secure to frame of Vehicle with two (2) u-bolts and four (4) nuts. Install Tube Cap in the upper Tube of the Mounting Bracket. See Illustration on page 12.

5. Slide Boom Assembly into Vehicle Frame leaving 1-1/2" clearance from the Frame Tube for the Hoses on the right side of Boom. Tighten Bolts; there will be 1" clearance after Bolts have been completely tighten.

6. Unfold Booms to allow access to the area the Hose Reel will be mounted.

7. Attach Caps to the ends of the Cross Tubes. Attach the cross tubs to the Hose Reel Mounting Brackets using three (3) 5/16 x 3-1/4" screws and four (4) nuts. The right rear 5/16 x 3 1/2" bolt attaches the "L" Bracket to the frame.

8. Mount the Hose Reel Assembly onto the Reel Mounting Assembly, using the four (4) 5/16 x 1-1/2" cap screws, 3/8" flat washers, 5/16" flat washers and lock Nuts.

9. Crimp the barrel connector onto the black ground wire extension and then to the NEGATIVE (-) (left) wire from the Reel Motor.

10. Tighten all fasteners securely in order to insure a solid, rigid installation.

11. Remove the screws holding the Cover to the Electric Box, to gain access to the electrical components mounted to the inside of the Box Cover.

12. Crimp the #10 ring terminal to the POSITIVE (+) (right) wire. Feed the POSITIVE (+) wire from the Reel Motor through the wire bushing in

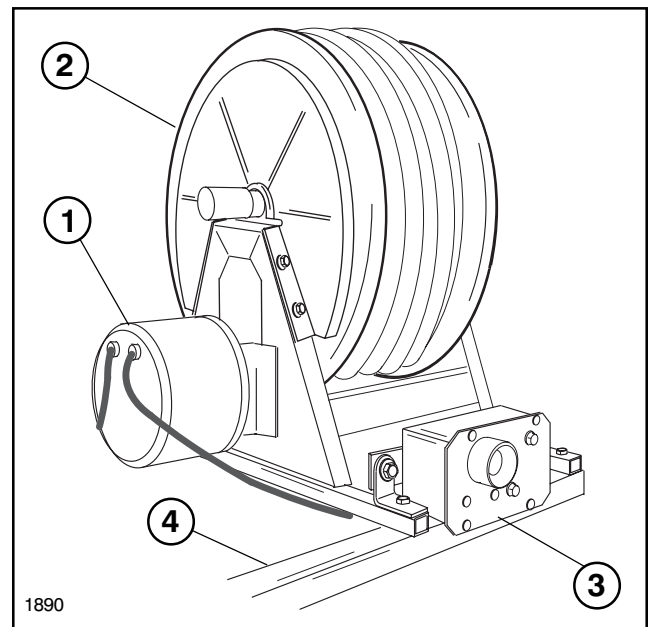

FIG. 1

- | | |
|------------------|---------------------------|
| 1. Reel Motor | 3. Electric Box ASM |
| 2. Hose Reel ASM | 4. Hose Reel Mounting ASM |

bottom of the Electric Box.

13. Connect the POSITIVE (+) wire to the open terminal on the circuit breaker, which is mounted on the Box Cover.

14. Apply a “bead” of silicone to the four flanges of the Electric Box. Replace the Box Cover, using four #10 x 1/2" machine screws, flat washers and hex nuts. Apply additional silicone to make a seal around the wires at the wire bushing.

15. Attach the Electrical Box Assembly to the "L" Bracket on the right Tube and at the rear of the Hose Reel Assembly, with a 3/8 x 1 flange cap screw and 3/8 flange lock nuts.

SET-UP

16. Route the ground and power wires from the reel motor to the electric box. Cut off approximately 13" of wire conduit, cover ground and power wires. Wire tie both ends. Cover ground and power wires from box to wire terminal ends. Cut off and discard excess conduit. Wire tie both ends.

17. Route the power wire along side of Tank behind Suction Hose and behind frame along side of Battery Cable and secure with wire ties to prevent the power wire from coming into contact with Muffler.

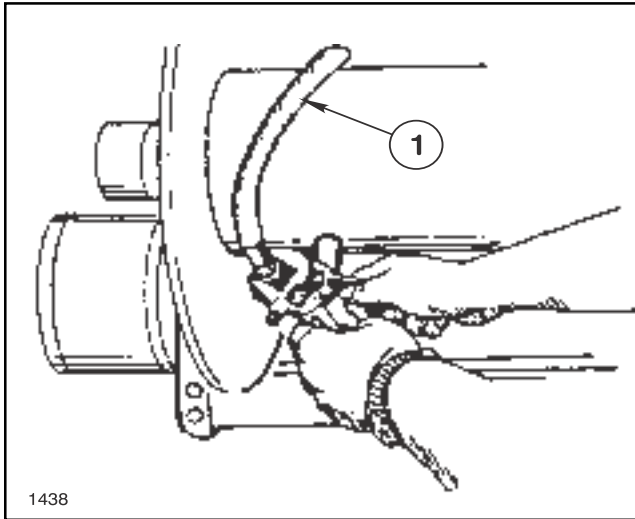

FIG. 2
1. Spray Hose

18. Connect the power wire to the Positive Terminal on Battery. The terminal end of the power wire should be inserted into the Positive Terminal rubber boot. Connect the ground wire to the Negative Terminal.

19. Reconnect the negative battery terminal.

CONNECTING THE SPRAY HOSE:

NOTE: Apply Teflon thread tape to all threads.

1. Hand thread the male hose connector into the connecting tube on the Reel Shaft. See FIG. 2.
2. Tighten the hose connector.
3. Assemble Hand Sprayer to Spray Hose and secure with Hose Clamp.

CONNECTING THE SUPPLY HOSE:

1. Install the hose barb into the Swivel Assembly as shown in FIG. 3 and secure the Supply Hose with a Hose Clamp.

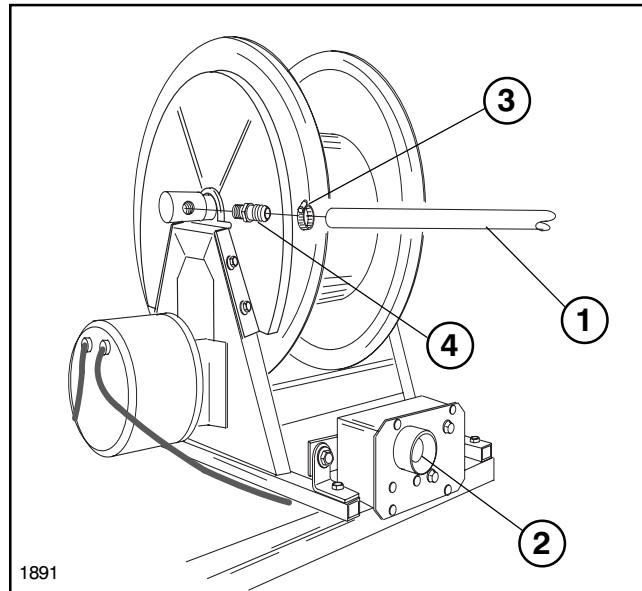

FIG. 3

- | | |
|----------------|----------------|
| 1. Supply Hose | 2. Reel Switch |
| 3. Hose Clamp | 4. Hose Barb |

2. Connect the other end of the Supply Hose as shown in the Hose Reel Plumbing Illustration on page 11, and by using the following instructions.

3. Disconnect Pressure Gauge, Pressure Hose, Boom Supply Hose and Relief Valve Hose from Tee to allow installation of Hose Plumbing.

4. Remove Tee and Tee Bracket ASM.

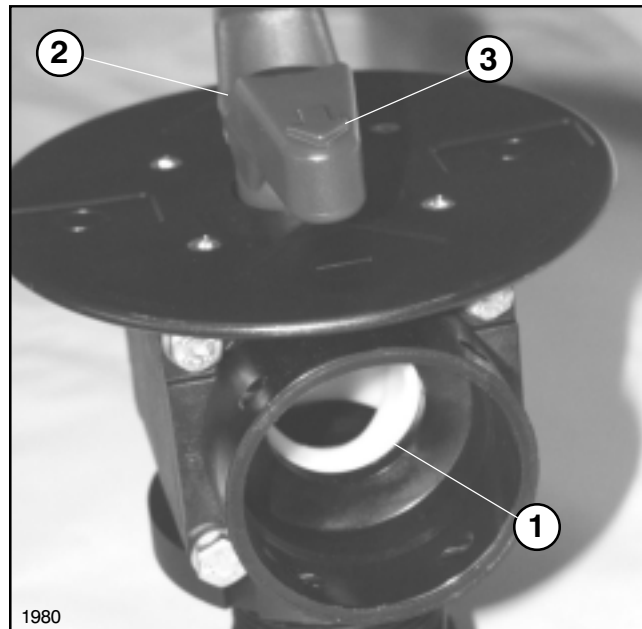

FIG. 4

- | | |
|-----------------|-----------|
| 1. Hole in Ball | 2. Handle |
| 3. Arrow | |

SET-UP

5. Verify that the arrow on the three-way valve handle is in line with the large hole in the Ball inside the Valve. If not, remove the screw from the center of the Handle and reorientate the Handle. Replace Screw. See FIG. 4, page 4.
6. The Three-Way Valve handle should have the arrow pointing toward the rear of vehicle. Tighten Adapter and Nut securely.
7. Attach Three-Way Valve ASM to the Tee ASM and secure with fork.
8. Attach valve assembly to the Valve Bracket using the two (2) existing #10-16 x 5/8 Lg. screws in the face of Valve.
9. Attach Support Bracket to Valve Bracket using two (2) 1/4-20 x 3/4 cap screws and two (2) flange nuts.
10. Attach Valve Bracket and Support Bracket to the tank valve Tee Bracket Assembly, using two (2) existing 1/4-20 x 3/4 cap screws and two (2) 1/4-20 x 3/4 cap screws and two (2) flange nuts from Parts Bag.
11. Place Spray Decal on Valve Bracket.
12. Reattach the Pressure Gauge, Pressure Hose and Relief Valve Hose removed in Step 3.
13. Attach Reel Supply and Boom Supply Hoses to Three-Way Valve and secure with forks. See Hose Reel Plumbing Illustration on page 11.

NOTES:

OPERATION

WINDING HOSE ONTO REEL:

NOTE: Be aware that the Reel Switch is an ON/OFF switch and does NOT control the speed of the winding action. Push the switch button intermittently when beginning to wind the hose onto an empty reel.

IMPORTANT! See Spray Hose Replacement, paragraph 4 & 5 and IMPORTANT note on page 8, for purging Hose before winding Hose onto the Reel.

1. Press and hold the Reel Switch while feeding the hose onto the spool. Feed the hose slowly and as evenly across the spool as possible.

IMPORTANT! If the reel stops winding, release the hose reel switch immediately. DO NOT pull or jerk on the Hose. Always find and correct the problem before continuing to rewind the hose.

UNWINDING THE HOSE:

1. Pull the hose from the reel by grasping the hose itself, not the Hand Sprayer.

IMPORTANT! If the reel stops unwinding, do NOT pull or jerk on the hose. Always find and correct the problem before continuing to unwind the hose.

OPERATING:

1. For Boom Spray the Three-Way Valve handle should be turned with arrow pointing toward the rear of vehicle. For Hand Spray the arrow on the Three-Way Valve handle should be pointing toward the front of vehicle. See FIG. 2.

2. Turn arrow on the Three-Way Valve handle toward the front of vehicle.

3. Start the vehicle with the Range selector in the Neutral position.

4. Shut off all boom section with Master ON/OFF foot switch or individual boom ON/OFF switches. Application Rate Button should be adjusted to full Increase (INCR +) (1250 only).

4a. Adjust Master Boom lever to "OFF" position (1200 only).

5. Engage Pump; increase engine speed until pressure gauge reads approximately 150 psi. Push the accelerator Lock Rocker Switch forward to "SET" position to engage the Throttle Lock.

6. If hand spraying at less than 150 psi is desired, rotate the Three-Way Valve handle counter-clockwise until desired pressure is obtained. See FIG. 2.

IMPORTANT: Maximum spray distance will be obtained at about 150 psi. Additional pressure will not increase spray distance. It will only atomize the spray mixture which will actually decrease spray distance. The engine is about half throttle to obtain 150 psi, increased engine speed will increase pressure. Spraying at the lowest pressure possible is desired, it decreases wear and tear on the system and reduces turf damage due to engine heat.

NOTE: For high volume walking boom applications it may be necessary to increase engine speed until pressure gauge reads approximately 200 psi. Push the Accelerator Lock Rocker Switch forward to "SET" position to engage the Throttle Lock.

CAUTION

The Hose Reel Spool is quick to respond when Reel Switch is pressed. To prevent personal injury and equipment damage, care should be used to avoid entanglement when winding Hose onto Reel.

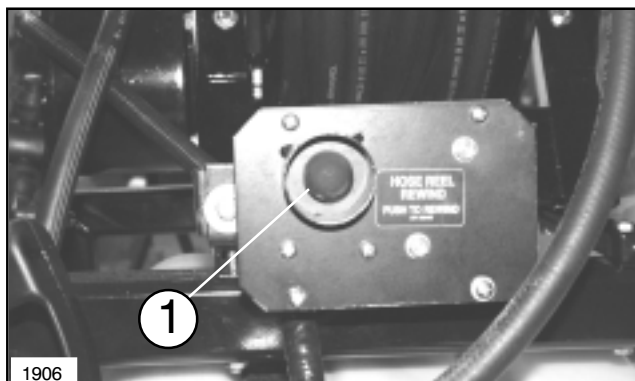

FIG. 1

1. Reel Switch

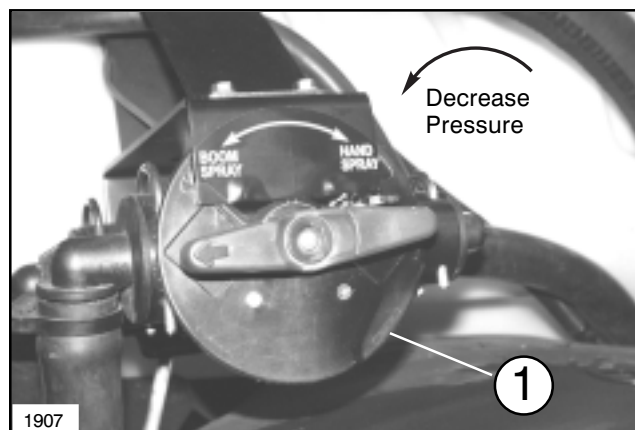

FIG. 2

1. Three-Way Valve

MAINTENANCE

With proper care your Hand Sprayer will give you reliable service. To maintain this performance, parts should be regularly replaced when necessary.

DISASSEMBLY PROCEDURE:

1. **Before** servicing or making any adjustments to the Sprayer:

- A. Stop the Vehicle and set the parking brake.
- B. Shut off the vehicle's engine and remove key from ignition.
- C. Disengage all power and wait until all moving parts have stopped.

If it becomes necessary to disassemble this unit, flush Hand Sprayer, detach from supply hose. Use Hand Sprayer ASM Illustration on page 16, FIG.1, this page and the following instructions for disassembling and assembling the Hand Sprayer.

HAND SPRAYER DISASSEMBLY:

1. Unscrew Nozzle Housing, this exposes a Nozzle and O-Ring. The Nozzle has a Flat and a tapered side. The flow volume through the Nozzle is greater with the flat side facing out towards the spray pattern. See the chart on page17 for flow rates at various pressures.
2. Removing the large O-Ring at the base of the Housing for Swirl exposes two Pins. Removing these two Pins allows the Housing for Swirl to be unscrewed and removed, this exposes an O-Ring and the Swirl. Unscrewing the Swirl exposes an O-Ring and ON-OFF Valve Seal.
3. Remove the seven Screws in the handle. Once the Screws are removed, the handle can be separated and the Tee Housing, Valve ASM, Trigger, Safety, and Trigger Stop are exposed.
4. Remove the Nut above the Hose Clamp on the Spray Hose. When disassembled, this will expose two O-Ring's and a Hosebarb.
5. Clean and inspect all parts. Replace worn or damaged parts.

HAND SPRAYER ASSEMBLY:

1. The Tee Housing, Valve ASM (with Sleeve Rubber and ON-OFF Cone), Trigger, Trigger Stop and the O-Ring must be placed in one side of the handle and the other side of the handle can be assembled using the seven screws.
2. Assemble the Hosebarb, and O-Ring's. Secure to bottom of the Tee Housing with Nut.
3. Assemble the ON-OFF Seal, and O-Ring to the Swirl and then screw the Swirl to the Front of the Tee Housing.
4. Assemble the O-Ring and Swirl Housing to the Swirl.
5. Secure the Swirl Housing with the two Pins and slide large O-Ring onto the Swirl Housing covering the two Pins.
6. Place the Nozzle and O-Ring into the Housing for the Nozzle and attach to the Swirl Housing.

STORAGE:

Flush and drain all liquid from the Hand Sprayer, and store in a safe, dry place.

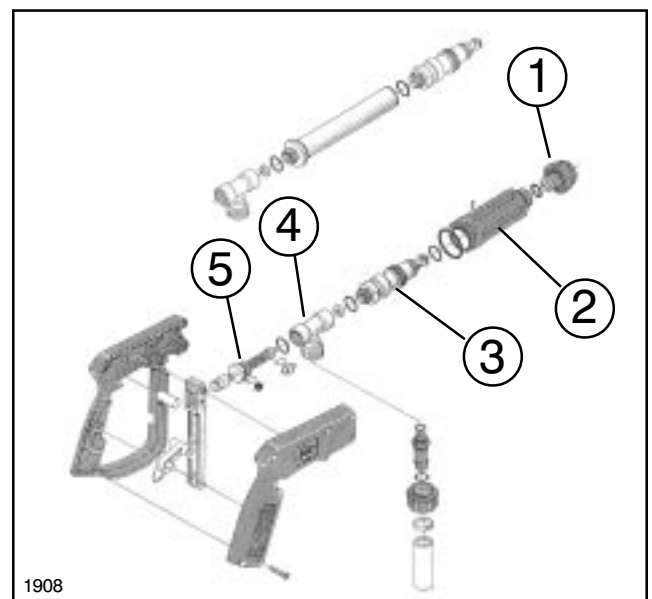

FIG. 1

- | | |
|-----------------------|------------------|
| 1. Housing for Nozzle | 2. Swirl Housing |
| 3. Swirl | 4. Tee Housing |
| 5. Valve ASM | |

MAINTENANCE

MOTOR REPLACEMENT:

1. Disconnect the Battery wire from the positive (+) and negative (-) post of the vehicle battery.
2. Cut the ground wire just below the butt splice connector, approximately 14" from the motor.
3. Remove the (4) #10 x 1/2" screws, washers, and nuts that secure the cover plate on the electric box assembly.
4. Disconnect the positive (+) wire of the reel motor from the terminal on the circuit breaker located on the cover plate assembly. Pull the wire out through the opening found in the bottom of the electric box.
5. Remove the (4) 5/16" x 1" hex hd cap screws, washers and nuts securing motor mounting bracket and motor to hose reel. Remove bracket and motor.
6. Remove the (4) 5/16" x 3/4" hex head cap screws and flat washers securing the motor mounting bracket to motor. Remove motor.
7. Loosen the set screw on the motor pinion and remove pinion and key from motor shaft.
8. Install pinion and key earlier removed on new motor shaft and secure by tightening the set screw securely.
9. Attach motor mounting bracket to motor using the (4) 5/16" x 3/4" hex head cap screws and flat washers. Tighten fasteners securely.
10. Loosely mount the motor mounting bracket and motor to the hose reel using the fasteners earlier removed.
11. Move motor mounting bracket and motor until pinion has engaged disc gear. Tighten fasteners securely.
12. Feed the positive (+) wire from the reel motor through the wire bushing in the bottom of the electric box and crimp a #10 ring terminal to the end of the wire.
13. Connect the positive (+) wire from the reel motor to the terminal on the circuit breaker located on the cover plate assembly.
14. Reinstall the cover plate assembly to the electrical box using the fasteners previously removed. Tighten fasteners securely.

15. Reconnect the motor negative (-) wire to the negative wire from battery with butt splice connector.

16. Reinstall the battery wire on the positive (+) and negative (-) post of the vehicle battery.

Spray Hose Replacement:



CAUTION

TO AVOID EXPOSURE TO SPRAY SOLUTION WHICH MAY CONTAIN HARMFUL CHEMICALS, DISENGAGE THE SPRAY PUMP (USING THE PUMP SWITCH) TO REMOVE PRESSURE BEFORE PERFORMING THE FOLLOWING PROCEDURE.

1. Unwind hose to be replaced and remove from Hose Reel. Hold riser outlet while removing hose connector.
2. Apply Teflon thread tape and hand thread the male hose connector into the outlet tube of the Inlet Assembly.
3. Using a wrench, firmly hold the outlet tube while tightening the hose connector.
4. Remove Hand Sprayer from damaged hose. Insert hosebarb into new hose and attach hose Clamp securely.
5. Open the Hose Reel Valve handle and pull trigger on Hand Sprayer to purge the hose of gases. When fluid appears, close the Hose Reel Valve handle.

IMPORTANT! Fully extend and charge the Spray Hose before winding it onto the Spool. This prevents the flattening of the hose resulting in excessive pressure on the spool when spraying is resumed and fluid supply is discharged under high pressure.

MAINTENANCE

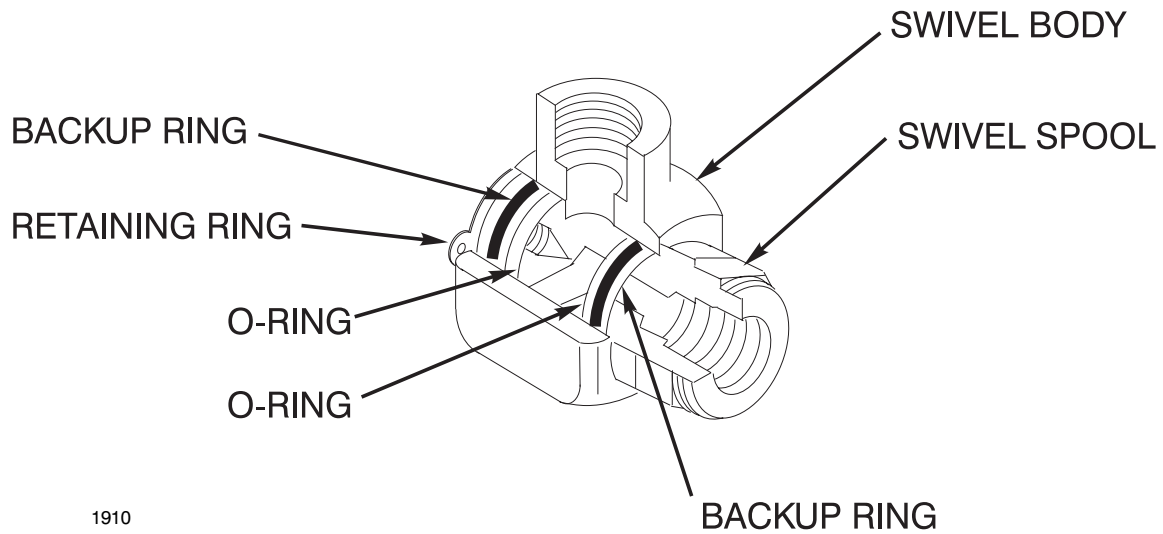

1910

FIG. 2

SWIVEL SEAL REPLACEMENT:

1. Turn off fluid supply, release line pressure and disconnect hoses from Swivel. It is recommended to use pipe caps on the ends of the hose to eliminate the possibility of foreign materials contaminating the system and/or excessive leaking of fluid.
2. Remove the Swivel from the axle by turning the Swivel Spool in a counterclockwise direction.
3. Relocate swivel to a clean area for disassembly and assembly.
4. Remove retaining ring and push Swivel Spool out to Swivel Body.
5. Remove old seals and O-Ring's from Spool. Using a clean rag, wipe all contaminants from Spool and Body.
6. Carefully slide O-Ring's over Spool into the same grooves that the old ones were removed from. **DO NOT** use any sharp objects to accomplish this operation as it can lead to a damaged seal.
7. Place Backup Ring's to the outside of the two O-Ring's, (See FIG. 2).
8. Allow at least 5 minutes for O-Ring's to compress back down to their original size to prevent possible cutting upon assembly.
9. Grease Spool using Lubriplate 630-2 or equivalent.
10. Insert Spool into Body and replace retaining ring to complete assembly.
11. Assemble Swivel to axle and reconnect hoses.
12. Turn on fluid supply, pressurize and test for leaks before use of reel.

NOTES:

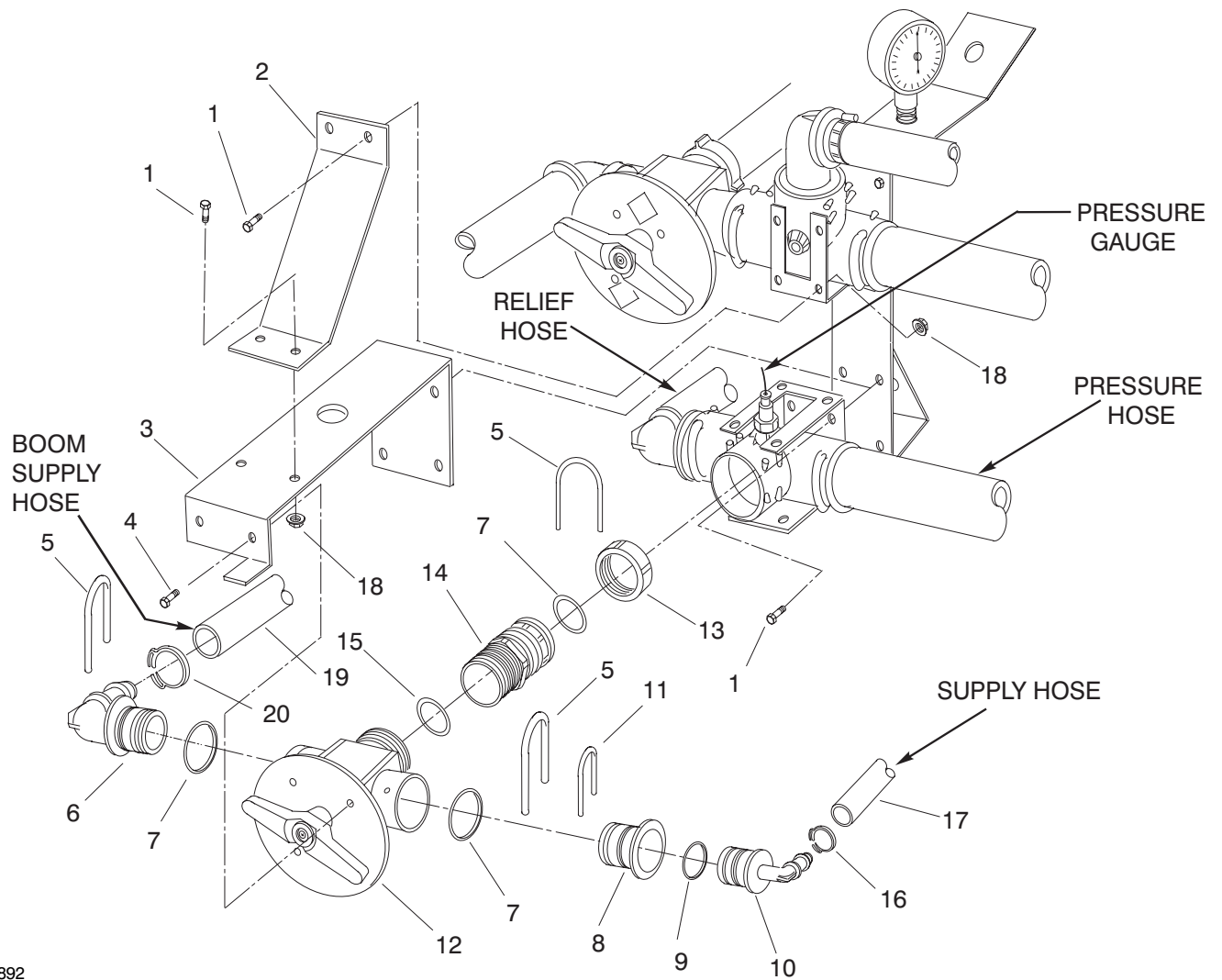

1892

HOSE REEL PLUMBING

Ref.	Part No.	Description	Qty
1	3234-4	Cap Screw	6
2	104-8728	Support Bracket	1
3	104-8727	Valve Bracket	1
4	32144-32	Screw	2
5	100-8635	Fork	3
6	100-8672	90° Hosebarb	1
7	100-8637	O-Ring	3
8	104-8855	Reducer	1
9	100-6712	O-Ring	1
10	100-6817	90° Hosebarb	1
11	100-6708	Fork	1

Ref.	Part No.	Description	Qty
12	104-8856	Valve	1
13	104-8857	Nut	1
14	104-8858	Adapter	1
15	100-8671	O-Ring	1
16	99-0772	Hose Clamp	1
17	104-8859	Hose	1
18	32128-33	Flange Nut	4
19	99-0783	Hose	1
20	99-0782	Hose Clamp	1
* 21	100-8578	Decal	1
* 22	095672	Hose Strap	6

*Not Illustrated

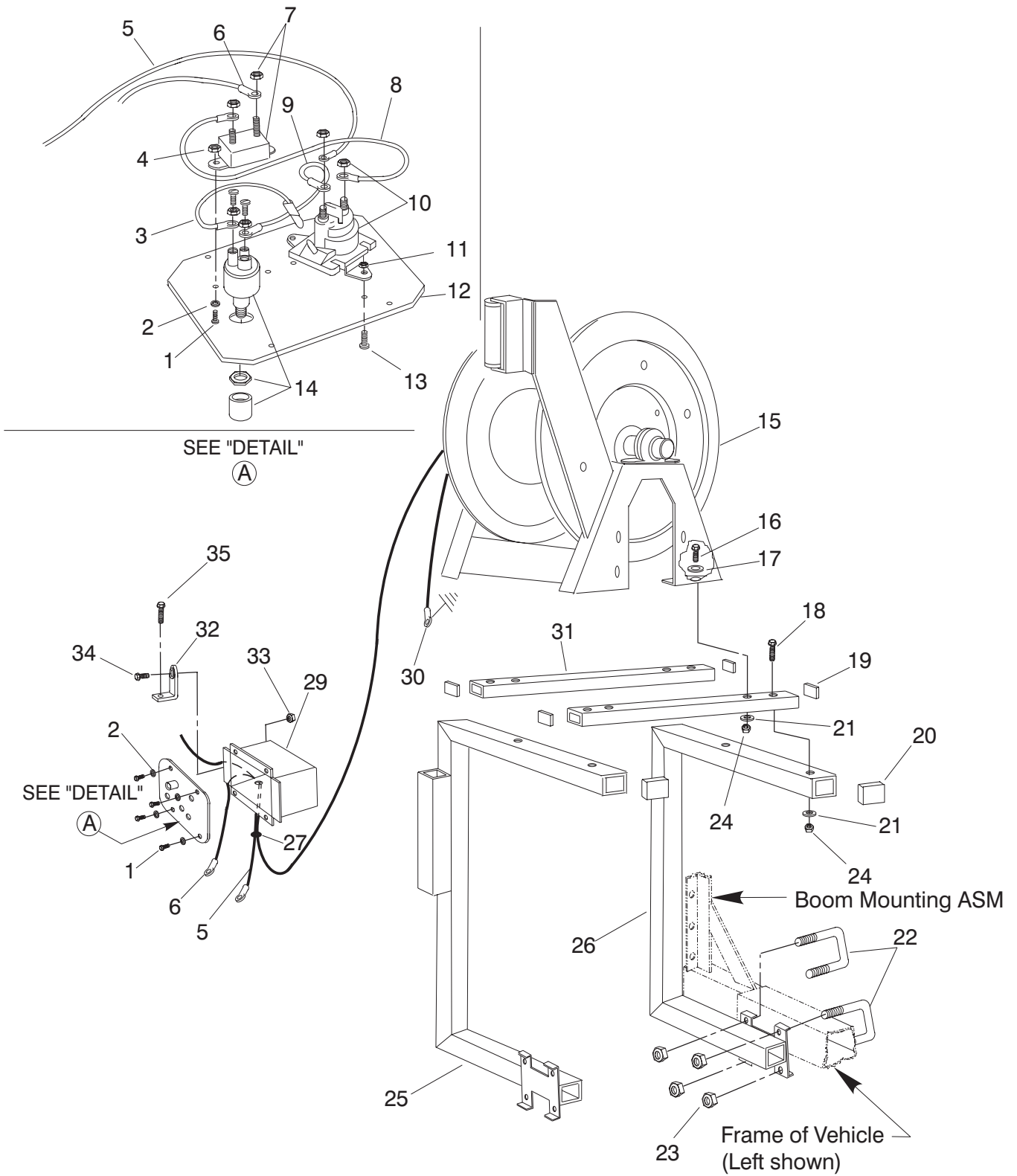

1894

HOSE REEL FRAME

Ref.	Part No.	Description	Qty
1	3250-31	HH Screw	6
2	3256-14	Flat Washer	6
3	42208	Wire ASM	1
4	3219-14	Hex Nut	6
5	42209	Wire ASM	1
6	42312	Insulated Terminal	1
7	42201	Circuit Breaker	1
8	42206	Wire ASM	1
9	42207	Wire ASM	1
10	41019	Solenoid	1
11	3217-5	Hex Nut	2
12	95-2495	Electrical Box Cover	1
13	32104-95	Hex Washer Hd. Screw	2
14	42202	Momentary Switch	1
15	104-8714	Hose Reel	1
16	322-7	Cap Screw	4
17	3256-4	Flat Washer	4

Ref.	Part No.	Description	Qty
18	322-20	Cap Screw	3
19	104-8726	Tube Cap	4
20	104-8725	Tube Cap	2
21	3256-23	Washer	4
22	100-7067	U-Bolt	4
23	32128-43	Flange Lock Nut	9
24	32128-20	Flange Lock Nut	8
25	104-8716	Hose Reel Mount R.H.	1
26	104-8717	Hose Reel Mount L.H.	1
27	95-2282	Grommet	1
28	104-8742	Conduit	1
29	42397	Electric Box ASM	1
30	104-8801	Ground Extension Wire	1
31	104-8723	Cross Bar	2
32	92-0450	"L" Bracket	1
33	32128-43	Flange Lock Nut	1
34	3234-11	Flange Lock Cap Screw	1
35	322-22	Cap Screw	1

*Not Illustrated

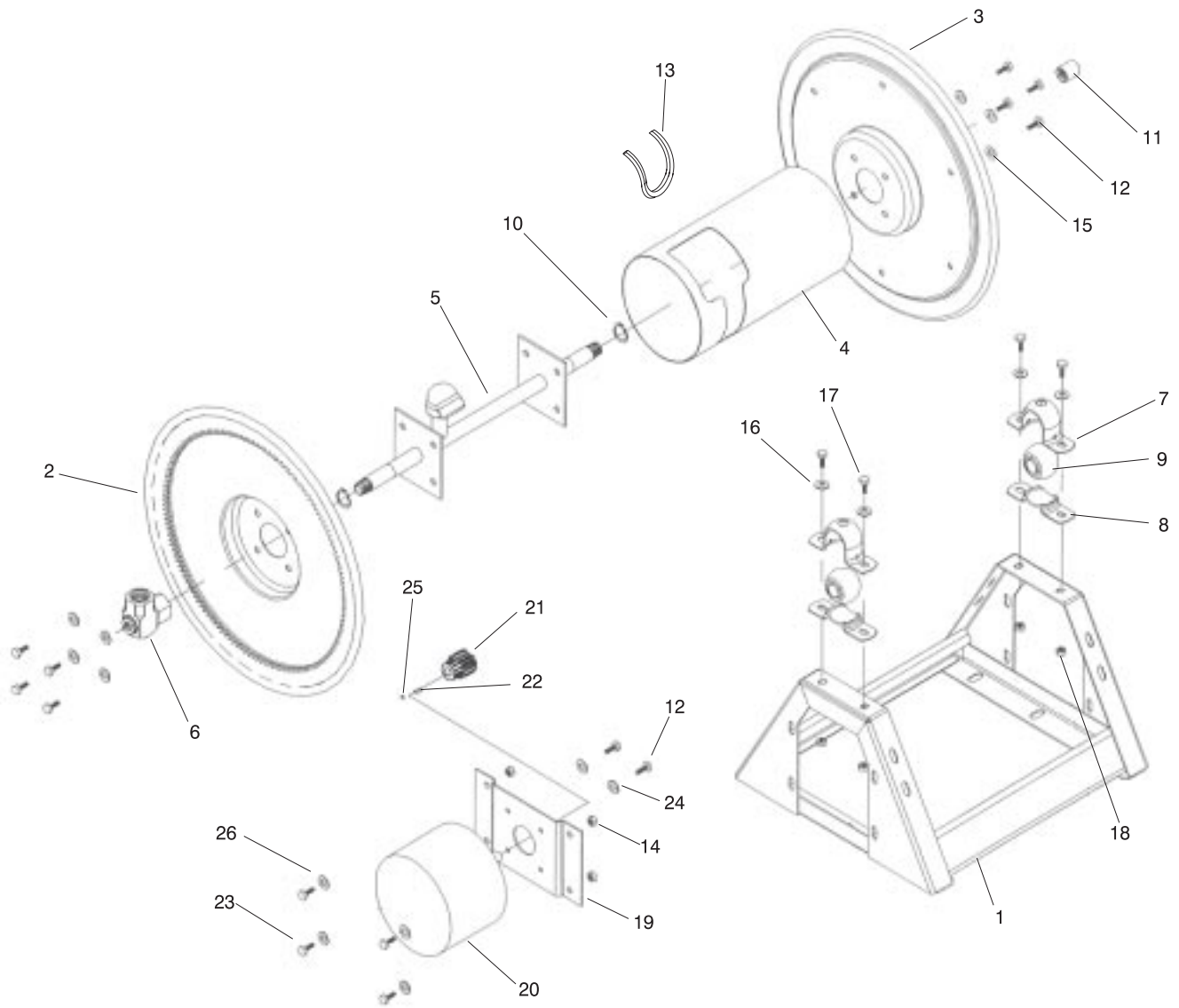

1905

HOSE REEL ASM

Ref.	Part No.	Description	Qty
1	104-8803	Frame ASM	1
2	104-8804	Disc & Gear ASM	1
3	104-8805	Disc Crank Side	1
4	104-8806	Center Drum	1
5	104-8807	Axle ASM	1
6	104-8808	Swivel ASM	1
7	104-8809	Pillow Block Mtg., Top	2
8	104-8810	Pillow Block Mtg., Bottom	2
9	104-8811	Bearing	2
10	104-8812	Retaining Ring	2
11	104-8813	Pipe Cap	1
12	322-3	Bolt	8
13	104-8814	Drum Edge Trim	1
*	104-8864	Swivel Seal Replacement Kit	1

Ref.	Part No.	Description	Qty
14	3296-29	Nut	4
15	3256-23	Lock Washer	8
16	3253-21	Lock Washer	4
17	323-6	Bolt	4
18	32128-21	Nut	1
19	104-8815	Bracket	1
20	104-8816	Motor, 12VDC	1
21	104-8817	Pinion	1
22	104-8818	Key	4
23	322-5	Bolt	4
24	3253-4	Washer	1
25	104-8819	Set Screw	4
26	3256-23	Washer	4

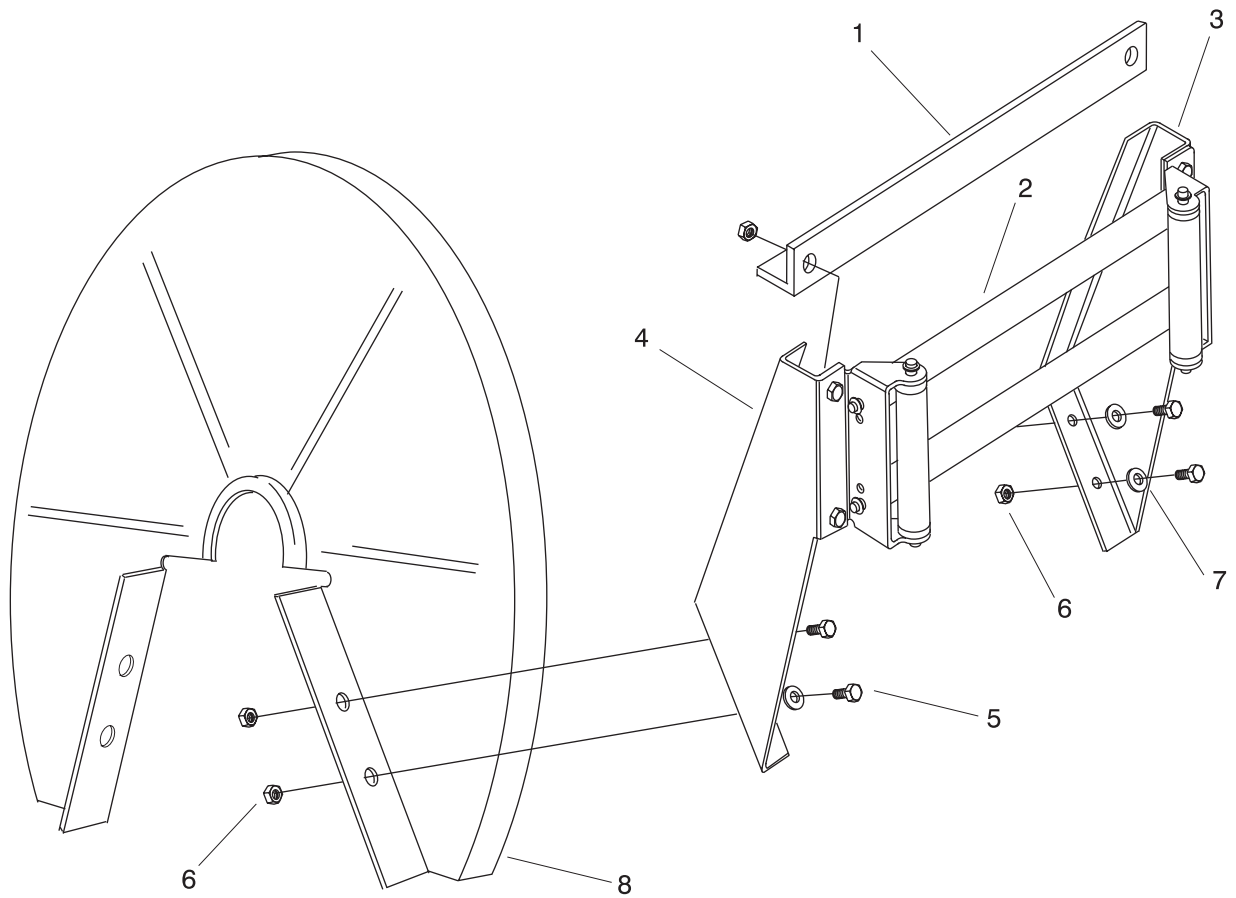

1902

GUARD AND GUIDE ASM

Ref.	Part No.	Description	Qty
1	104-8800	Bracket	1
2	104-8799	Bracket w/Fasteners	1
3	104-8820	Bracket- Right	1
4	104-8821	Bracket- Left	1

Ref.	Part No.	Description	Qty
5	322-5	Screw	4
6	3296-29	Nut	4
7	3256-23	Washer	4
8	104-8715	Guard	1

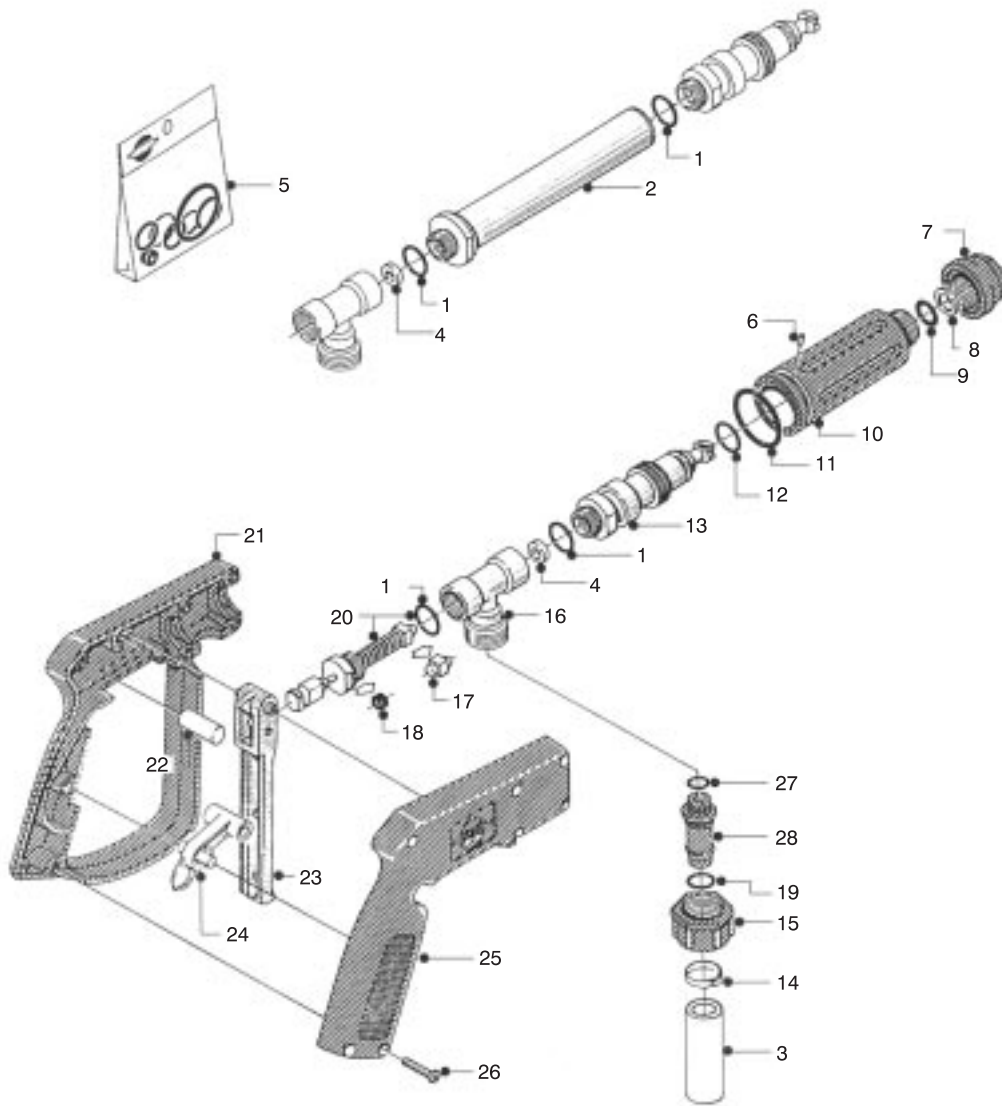

1855



HAND SPRAYER ASM

Ref.	Part No.	Description	Qty
1	100-6649	O-Ring	3
2	99-0885	Lance Ext. For 60L Hand Sprayer	1
3	104-8730	Hose- 150'- 200PSI	1
4	99-0884	Seal for On/Off Valve	1
5	99-0779	Repair Kit For Hand Sprayer	1
6	99-0887	Pin	1
7	99-0890	Housing For Nozzle	1
8	99-0889	Nozzle Ceramic	1
9	100-6650	O-Ring	1
10	99-0886	Housing For Swirl	1
11	100-6646	O-Ring	1
12	100-6644	O-Ring	1
13	99-0780	Swirl For Hand Sprayer	1
14	99-0772	Hose Clamp	1

Ref.	Part No.	Description	Qty
15	99-0766	Nut	1
16	99-0883	Tee Housing	1
17	104-8860	Cone For On/Off	1
18	104-8861	Sleeve Rubber	1
19	100-6647	O-Ring	1
20	99-0882	Valve ASM	1
21	99-0877	Handle L.H.	1
22	99-0878	Stop Rubber For Trigger	1
23	99-0880	Trigger Arm	1
24	99-0879	Trigger Safety Arm	1
25	99-0881	Handle R.H.	1
26	100-6666	Screw	1
27	100-6648	O-Ring	1
28	99-0849	Hosebarb	1

NOZZLE FLOW

NOZZLE CAPACITIES (GPM)

PRESSURE IN PSI	99-0889 NOZZLE	
DIRECTION OF FLOW		
15	0.588	0.464
20	0.678	0.538
30	0.829	0.661
35	0.895	0.715
40	0.956	0.766
50	1.068	0.857
60	1.169	0.940
70	1.261	1.018
100	1.504	1.222
150	1.840	1.500

NOTES:

NOTES:

The Toro General Commercial Products Warranty

A Two-Year Limited Warranty

Conditions and Products Covered

The Toro Company and its affiliate, Toro Warranty Company, pursuant to an agreement between them, jointly warrant your 1996 or newer Toro Commercial Product ("Product") purchased after January 1, 1997, to be free from defects in materials or workmanship for two years or 1500 operational hours*, whichever occurs first. Where a warrantable condition exists, we will repair the Product at no cost to you including diagnosis, labor, parts, and transportation. This warranty begins on the date the Product is delivered to the original retail purchaser.

* Product equipped with hour meter

Instructions for Obtaining Warranty Service

You are responsible for notifying the Commercial Products Distributor or Authorized Commercial Products Dealer from whom you purchased the Product as soon as you believe a warrantable condition exists.

Toro Commercial Products Service Department
Toro Warranty Company
8111 Lyndale Avenue South
Bloomington, MN 55420-1196
612-888-8801
800-982-2740
E-mail: commercial.service@toro.com

Owner Responsibilities

As the Product owner, you are responsible for required maintenance and adjustments stated in your operator's manual. Failure to perform required maintenance and adjustments can be grounds for disallowing a warranty claim

Items and Conditions Not Covered

Not all product failures or malfunctions that occur during the warranty period are defects in materials or workmanship. This express warranty does not cover:

- Product failures which result from the use of non-Toro replacement parts, or from installation and use of add-on, modified, or unapproved accessories.
- Product failures which result from failure to perform required maintenance and/or adjustments.
- Product failures which result from operating the Product in an abusive, negligent or reckless manner.
- Parts subject to consumption through use unless found to be defective. Examples of parts which are consumer, or used up, during normal Product operation include, but are not limited to, blades, reels, bedknives, tines, spark plugs, castor wheels, tires, filters, belts, etc.

- Failures caused by outside influence, items considered to be outside influence include, but are not limited to, weather storage practices, contamination, use of unapproved coolants, lubricants, additives, or chemicals, etc.

- Normal "wear and tear" items. Normal "wear and tear" includes, but is not limited to, damage to seats due to wear or abrasion, worn painted surfaces, scratched decals or windows, etc.

Parts

Parts scheduled for replacement as required maintenance are warranted for the period of time up to the scheduled replacement time for that part.

Parts replaced under this warranty become the property of Toro. Toro will make the final decision whether to repair any existing part or assembly or replace it. Toro may use factory remanufactured parts rather than new parts for some warranty repairs.

General Conditions

Repair by an Authorized Toro Distributor or Dealer is your sole remedy under this warranty.

Neither The Toro Company nor Toro Warranty Company is liable for indirect, incidental or consequential damages in connection with the use of the Toro Products covered by this warranty, including any cost or expense of providing substitute equipment or service during reasonable periods of malfunction or non-use pending completion of repairs under this warranty. Except for the Emissions warranty referenced below, if applicable, there is no other express warranty. All implied warranties of merchantability and fitness for use are limited to the duration of this express warranty.

Some states do not allow exclusions of incidental or consequential damages, or limitations on how long an implied warranty lasts, so the above, exclusions and limitations may not apply to you.

This warranty gives you specific legal rights, and you may also have other rights which vary from state to state.

Note regarding engine warranty: The Emissions Control System on your Product may be covered by a separate warranty meeting requirements established by the U. S. Environmental Protection Agency (EPA) and/or the California Air Resources Board (CARB). The hour limitations set forth above do not apply to the Emissions Control System Warranty. Refer to the Engine Emission Control Warranty Statement printed in your operator's manual or contained in the engine manufacturer's documentation for details.

Countries Other than the United States or Canada

Customers who have purchased Toro products exported from the United States or Canada should contact their Toro Distributor (Dealer) to obtain guarantee policies for your country, province, or state. If for any reason you are dissatisfied with your Distributor's service or have difficulty obtaining guarantee information, contact the Toro importer. If all other remedies fail, you may contact us at Toro Warranty Company.