



Model No. 41415-70101 & UP

SET-UP AND PARTS
CATALOG

TRAILER PACKAGE

for the 110 GAL. & 160 GAL. SKID SPRAYERS

NOTE: The following instructions are for the 160 Gallon Skid Sprayer only. For set-up instructions for the 110 Gallon Skid Sprayer refer to the set-up instructions with that kit. Keep this manual for Parts List on reverse side.

NOTE: The tree Tube Spacers, (one in front and two at the rear) are included with the Skid Frame to permit mounting the Skid Frame in a transport vehicle. They are not used with the Trailer Package and must be removed before installing the Trailer Package.

1. Mount the Rear Axle and Tire Assembly to the Skid Frame as shown in FIG. 1, using two (2) 3/8" x 1-1/4" hex hd. cap screws, lock washer, hex nuts and four (4) flat washer on each side of the Skid. Torque to 30 ft. lbs.

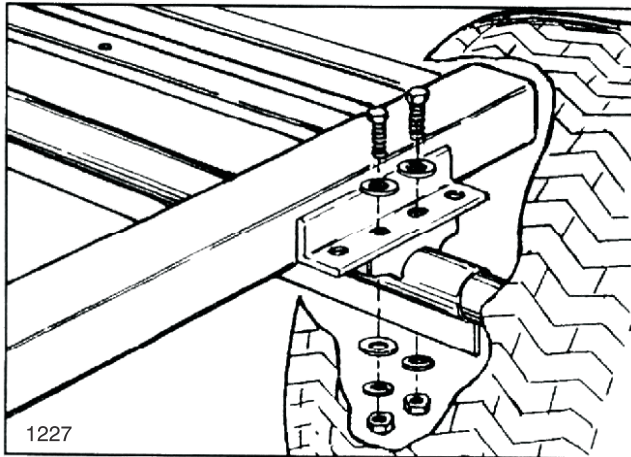

FIG. 1

2. Mount the Tongue and Jack Assembly to the underside of the Skid Frame as shown in FIG. 2, using four (4) 1/2" x 1-1/4" hex hd. cap screws and hex nuts. Torque to 50 ft. lbs.

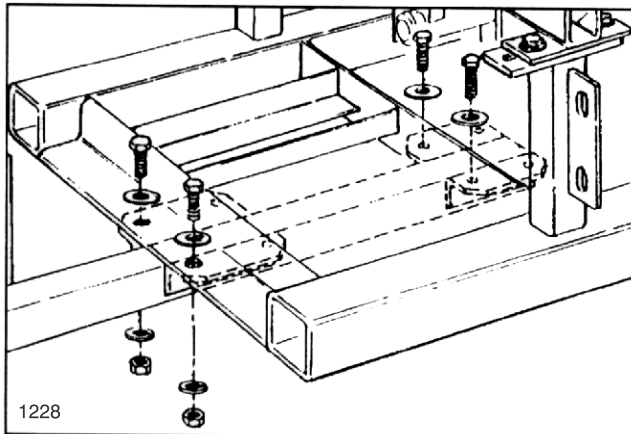

FIG. 2

3. With the Jack positioned as shown in FIG. 3, turn the Crank Handle to raise or lower the height of the Trailer's hitch yoke to be in alignment with the hitch on your transport vehicle.

4. Secure with Hitch Pin and insert the cotter pin as shown.

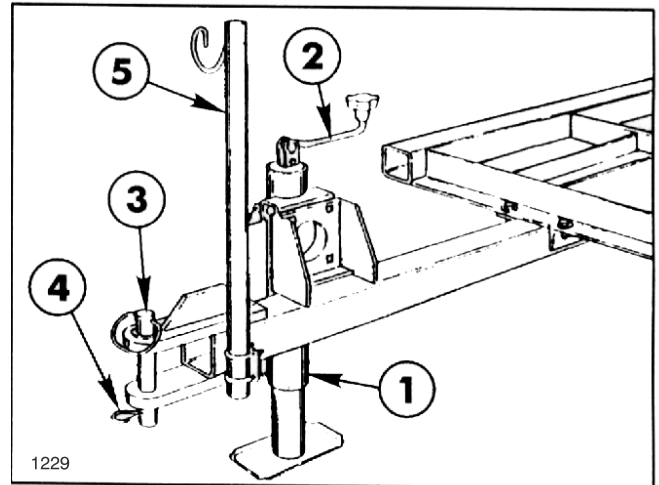

FIG. 3

1. Jack
2. Crank Handle
3. Hitch Pin
4. Cotter Pin
5. Harness Tube

5. Loop the Wiring Harness through the ring at the top of the Harness-Tube Assembly to prevent it from dragging the ground or becoming entangled in the transport vehicle's rear axle or PTO mechanism.

DURING TRANSPORT

Grasp the "V" ring in the plunger pin and pull it out until the Jack can be pivoted as shown in FIG. 4.

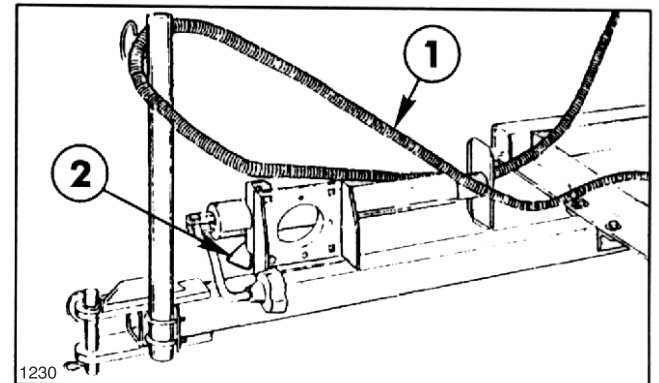
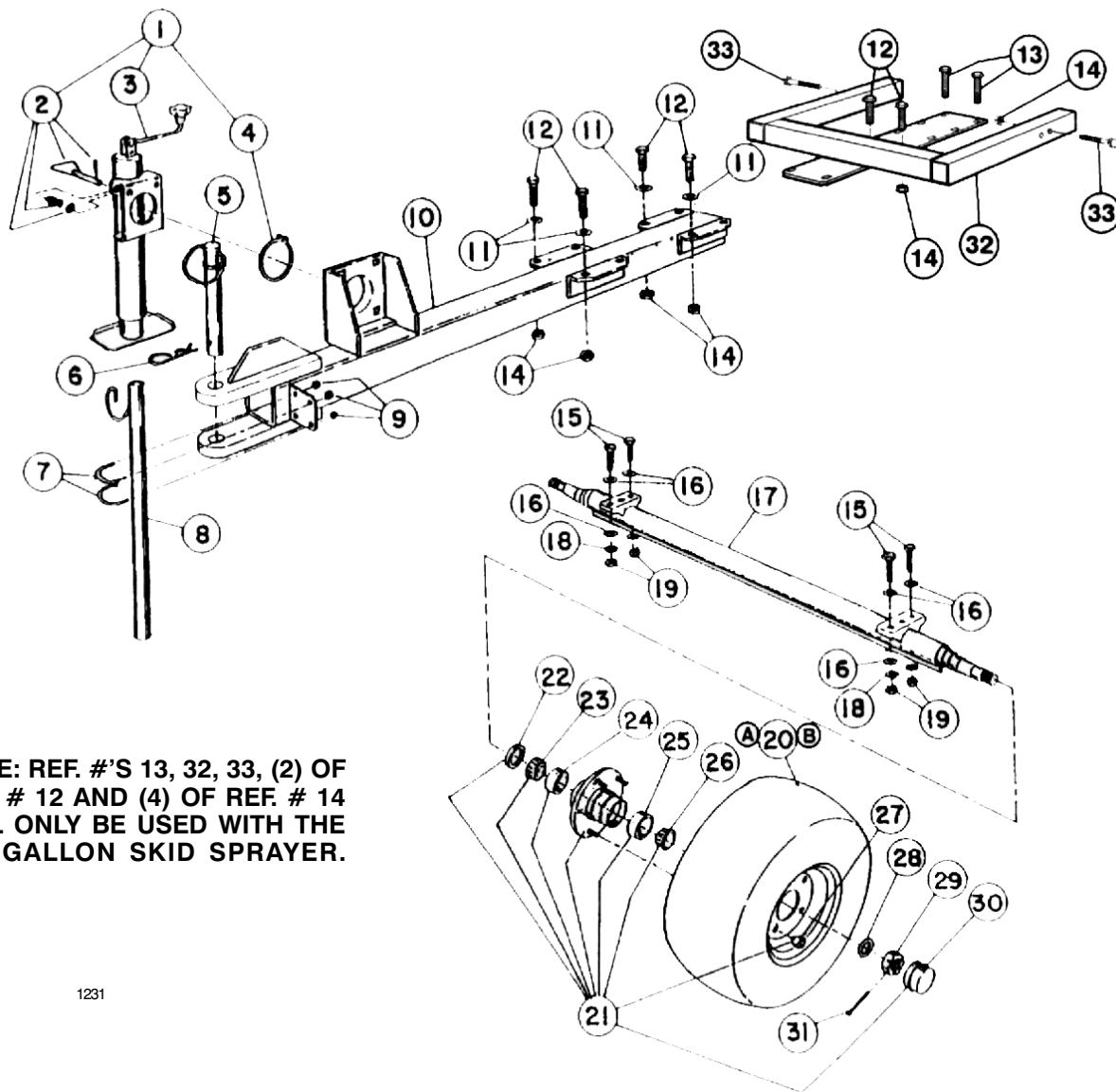

FIG. 4

1. wiring harness
2. Plunger Pin



NOTE: REF. #'S 13, 32, 33, (2) OF REF. # 12 AND (4) OF REF. # 14 WILL ONLY BE USED WITH THE 110 GALLON SKID SPRAYER.

1231

MODEL 41415 TRAILER PACKAGE

#	Part No.	Description	Qty
1	92-0270	Swivel Jack	1
2	92-3617	Plunger Assembly (f/w 92-0270)	1
3	92-3616	Crank Assembly (f/w 92-0270)	1
4	92-3615	Retaining Ring (f/w 92-0270)	1
5	92-0341	Hitch Pin	1
6	30908	Cotter Pin	1
7	92-0010	U-Bolt, 1/4"	2
8	92-0278	Harness Tube Assembly	1
9	3217-5	Hex Nut, 1/4"	4
10	92-0263	Tongue Assembly	1
11	3256-26	Flat Washer, 1/2"	4
12	325-5	Cap Screw, 1/2"	6
13	325-6	Cap Screw, 1/2 x 1-1/2"	2
14	32128-49	Hex Nut, 1/2"	4
15	3211-5	Cap Screw, 3/8 x 1-1/4"	4
16	3256-24	Flat Washer, 3/8"	8
17	92-0272	Axle Assembly	1
18	3253-11	Lock Washer, 3/8"	4
19	3219-3	Hex Nut, 3/8"	4
20A	42684	Wheel & Tire Ass'y (24 x 13 x 12")	2
	42667	Wheel Rim (f/w 42684)	2
	42685	Tire (f/w 42684)	2

#	Part No.	Description	Qty
20B	42329	Wheel & Tire Ass'y (23 x 10.5 x 12")	2
	41169	Wheel Rim (f/w 42329)	2
	42330	Tire (f/w 42329)	2
21	99-0579	Hub Assembly	2
22	92-8403	Seal (f/w 92-0275)	2
23	92-8398	Bearing Cone, 1-3/8" (f/w 92-0275)	2
24	92-8399	Bearing Cup, 1-3/8" (f/w 92-0275)	2
25	92-8401	Bearing Cup, 1-1/16" (f/w 92-0275)	2
26	92-8400	Bearing Cone, 1-1/16" (f/w 92-0275)	2
27	23-7270	Lug Nut	10
28	358042	Special Washer	2
29	32136-5	Slotted Hex Nut, 3/4"	2
30	92-8402	Dust Cap	2
31	3272-13	Cotter Pin, 1/8 x 1-1/2"	2
32	95-9079	Tongue Adapter	1
33	325-14	Cap Screw, 1/2 x 3-1/2"	2

* Not illustrated