



Mid-Size Mower

ProLine Hydro 15 HP with 44 in. Side Discharge Mower

Model No. 30434—Serial No. 230000001 and Up

Operator's Manual



Warning



CALIFORNIA

Proposition 65 Warning

The engine exhaust from this product contains chemicals known to the State of California to cause cancer, birth defects, or other reproductive harm.

Important This engine is not equipped with a spark arrester muffler. It is a violation of California Public Resource Code Section 4442 to use or operate this engine on any forest-covered, brush-covered or grass-covered land. Other states or federal areas may have similar laws.

This spark ignition system complies with Canadian ICES-002.

Ce système d'allumage par étincelle de véhicule est conforme à la norme NMB-002 du Canada.

The enclosed Engine Owner's Manual is supplied for information regarding The U.S. Environmental Protection Agency (EPA) and the California Emission Control Regulation of emission systems, maintenance and warranty.

Keep this engine Owner's Manual with your unit. Should this engine Owner's Manual become damaged or illegible, replace immediately. Replacements may be ordered through the engine manufacturer.

Contents

	Page
Introduction	3
Safety	3
Safe Operating Practices	3
Toro Mower Safety	5
Slope Chart	7
Safety and Instruction Decals	9
Gasoline and Oil	12
Recommended Gasoline	12
Using Stabilizer/Conditioner	12
Filling the Fuel Tank	12
Check Engine Oil Level	12
Setup	13
Loose Parts	13
Installing the Handle Assembly	14
Installing the Fuel Tank	14
Installing the Control Rods	15
Installing the Speed Control Rod	16
Installing the Hairpin Cotter Pins and Washers ..	16

	Page
Checking the Tire Pressure	16
Checking the Hydraulic Fluid and Engine Oil ..	17
Setting Up the Hydro Linkage	17
Operation	17
Think Safety First	17
Controls	17
Starting and Stopping the Engine	18
Operating Neutral Locks	19
Operating the Parking Brake	19
Operating Mower Blade Control (PTO)	20
The Safety Interlock System	20
Driving Forward or Backward	21
Bringing Machine to Neutral Position	21
Stopping the Machine	21
Pushing the Machine by Hand	21
Transporting Machines	22
Side Discharge or Mulch Grass	22
Adjusting the Height-of-Cut	22
Adjusting the Gage Wheels	23
Adjusting the Handle Height	24
Using the Mid-Size Weight Kit	25
Maintenance	26
Recommended Maintenance Schedule	26
Servicing the Air Cleaner	27
Servicing the Engine Oil	28
Servicing the Spark Plug	29
Fuse Service	30
Greasing and Lubrication	31
Cleaning the Cooling System	31
Checking the Tire Pressure	32
Adjusting the Electric Clutch	32
Servicing the Fuel Tank	32
Servicing the Fuel Filter	33
Servicing the Hydraulic System	33
Hydro Linkage Adjustments	35
Adjusting the Speed Control Linkage	35
Temporary Neutral Stud Adjustment	36
Adjusting the Hydro Control Linkages	36
Adjusting the Neutral Stud	38
Adjusting the Control Rod	39
Adjusting the Tracking	40
Servicing the Brake	40
Adjusting the Electric Clutch	41
Servicing the Cutting Blades	41
Correcting the Mower Quality of Cut	43
Frame Set Up	43
Checking the Deck Front-to-Rear Pitch	45
Changing the Deck Front-to-Rear Pitch	45
Checking the Deck Side-to-Side Leveling	46

	Page
Changing the Side-to-Side Leveling	46
Matching the Height of Cut	46
Replacing the Mower Belt	47
Replacing the PTO Drive Belt	47
Replacing the Caster Wheel Fork Bushings	48
Caster Wheel and Bearings Service	49
Replacing the Grass Deflector	49
Wiring Diagram	50
Hydraulic Diagram	51
Cleaning and Storage	52
Troubleshooting	52
The Toro Total Coverage Guarantee	56

Introduction

Read this manual carefully to learn how to operate and maintain your product properly. The information in this manual can help you and others avoid injury and product damage. Although Toro designs and produces safe products, you are responsible for operating the product properly and safely.

Whenever you need service, genuine Toro parts, or additional information, contact an Authorized Service Dealer or Toro Customer Service and have the model and serial numbers of your product ready. Figure 1 illustrates the location of the model and serial numbers on the product.

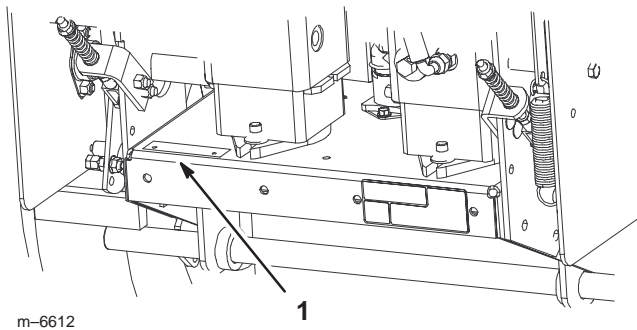

m-6612

Figure 1

1. Location of the model and serial numbers

Write the product model and serial numbers in the space below:

Model No. _____
Serial No. _____

This manual identifies potential hazards and has special safety messages that help you and others avoid personal injury and even death. **Danger**, **Warning**, and **Caution** are signal words used to identify the level of hazard. However, regardless of the hazard, be extremely careful.

Danger signals an extreme hazard that *will* cause serious injury or death if you do not follow the recommended precautions.

Warning signals a hazard that *may* cause serious injury or death if you do not follow the recommended precautions.

Caution signals a hazard that may cause minor or moderate injury if you do not follow the recommended precautions.

This manual uses two other words to highlight information. **Important** calls attention to special mechanical information and **Note**: emphasizes general information worthy of special attention.

Safety

Note: The addition of attachments made by other manufacturers that do not meet American National Standards Institute certification will cause noncompliance of this machine.

Improper use or maintenance by the operator or owner can result in injury. To reduce the potential for injury, comply with these safety instructions and always pay attention to the safety alert ⚠ symbol, which means CAUTION, WARNING, or DANGER—"personal safety instruction." Failure to comply with the instruction may result in personal injury or death.

Safe Operating Practices

The following instructions are from ANSI standard B71.4—1999.

Training

- Read the Operator's Manual and other training material. If the operator(s) or mechanic(s) can not read English it is the owner's responsibility to explain this material to them.
- Become familiar with the safe operation of the equipment, operator controls, and safety signs.
- All operators and mechanics should be trained. The owner is responsible for training the users.
- Never let children or untrained people operate or service the equipment. Local regulations may restrict the age of the operator.

- The owner/user can prevent and is responsible for accidents or injuries occurring to himself or herself, other people or property.

Preparation

- Evaluate the terrain to determine what accessories and attachments are needed to properly and safely perform the job. Only use accessories and attachments approved by the manufacturer.
- Wear appropriate clothing including hard hat, safety glasses and hearing protection. Long hair, loose clothing or jewelry may get tangled in moving parts.
- Inspect the area where the equipment is to be used and remove all objects such as rocks, toys and wire which can be thrown by the machine.
- Use extra care when handling gasoline and other fuels. They are flammable and vapors are explosive.
 - Use only an approved container
 - Never remove gas cap or add fuel with engine running. Allow engine to cool before refueling. Do not smoke.
 - Never refuel or drain the machine indoors.
- Check that operator's presence controls, safety switches and shields are attached and functioning properly. Do not operate unless they are functioning properly.

Operation

- Never run an engine in an enclosed area.
- Only operate in good light, keeping away from holes and hidden hazards.
- Be sure all drives are in neutral and parking brake is engaged before starting engine. Only start engine from the operator's position.
- Be sure of your footing while using this machine, especially when backing up. Walk, don't run. Never operate on wet grass. Reduced footing could cause slipping.
- Slow down and use extra care on hillsides. Be sure to travel side to side on hillsides. Turf conditions can affect the machine's stability. Use caution while operating near drop-offs.
- Slow down and use caution when making turns and when changing directions on slopes.
- Never raise deck with the blades running.
- Never operate with the PTO shield, or other guards not securely in place. Be sure all interlocks are attached, adjusted properly, and functioning properly.

- Never operate with the discharge deflector raised, removed or altered, unless using a grass catcher.
- Do not change the engine governor setting or overspeed the engine.
- Stop on level ground, disengage drives, engage parking brake (if provided), shut off engine before leaving the operator's position for any reason including emptying the catchers or unclogging the chute.
- Stop equipment and inspect blades after striking objects or if an abnormal vibration occurs. Make necessary repairs before resuming operations.
- Keep hands and feet away from the cutting unit.
- Look behind and down before backing up to be sure of a clear path.
- Keep pets and bystanders away.
- Slow down and use caution when making turns and crossing roads and sidewalks. Stop blades if not mowing.
- Be aware of the mower discharge direction and do not point it at anyone.
- Do not operate the mower under the influence of alcohol or drugs.
- Use care when loading or unloading the machine into or from a trailer or truck.
- Use care when approaching blind corners, shrubs, trees, or other objects that may obscure vision.

Maintenance and storage

- Disengage drives, set parking brake, stop engine and remove key or disconnect spark plug wire. Wait for all movement to stop before adjusting, cleaning or repairing.
- Clean grass and debris from cutting unit, drives, mufflers, and engine to help prevent fires. Clean up oil or fuel spillage.
- Let engine cool before storing and do not store near flame.
- Shut off fuel while storing or transporting. Do not store fuel near flames or drain indoors.
- Park machine on level ground. Set parking brake. Never allow untrained personnel to service machine.
- Use jack stands to support components when required.
- Carefully release pressure from components with stored energy.
- Remove spark plug wire before making any repairs.

- Use care when checking blades. Wrap the blade(s) or wear gloves, and use caution when servicing them. Only replace blades. Never straighten or weld them.
- Keep hands and feet away from moving parts. If possible, do not make adjustments with the engine running.
- Keep all parts in good working condition and all hardware tightened. Replace all worn or damaged decals.

Toro Mower Safety

The following list contains safety information specific to Toro products and other safety information you must know.

This product is capable of amputating hands and feet and throwing objects. Always follow all safety instructions to avoid serious injury or death.

This product is designed for cutting and recycling grass or, when equipped with a grass bagger, for catching cut grass. Any use for purposes other than these could prove dangerous to user and bystanders.

General Operation

- Allow only responsible adults who are familiar with the instructions to operate the machine.
- Be sure the area is clear of other people before mowing. Stop the machine if anyone enters the area.
- Do not mow in reverse unless absolutely necessary. Always look down and behind before and while backing.
- Be aware of the mower discharge direction and do not point it at anyone. Do not operate the mower without either the entire grass catcher or the guard in place.
- Slow down before turning. Sharp turns on any terrain may cause loss of control.
- Turn off blades when not mowing.
- Keep hands, feet, hair and loose clothing away from attachment discharge area, underside of mower and any moving parts while engine is running.
- Stop the engine before removing the grass catcher or unclogging the chute.
- Mow only in daylight or good artificial light.
- Watch for traffic when operating near or crossing roadways.
- Do not touch equipment or attachment parts which may be hot from operation. Allow to cool before attempting to maintain, adjust or service.

- Use only Toro-approved attachments. Warranty may be voided if used with unapproved attachments.

Slope Operation

Slopes and ramps are a major factor related to loss-of-control and accidents, which can result in severe injury or death. All slopes and ramps require extra caution. If you feel uneasy on a slope, do not mow it.

DO

- Remove obstacles such as rocks, tree limbs, etc. from the mowing area.
- Watch for holes, ruts or bumps. Tall grass can hide obstacles.
- Use slow speed so that you will not have to stop while on the slope.
- Use extra care with grass catchers or other attachments. These can change the stability of the machine.
- Keep all movement on slopes slow and gradual. Do not make sudden changes in speed or direction.
- Avoid starting or stopping on a slope. If tires lose traction, disengage the blades.
- Check carefully for overhead clearances (i.e. branches, doorways, electrical wires) before driving under any objects and do not contact them.
- Mow slopes side to side.

DO NOT

- Do not mow slopes greater than 15 degrees.
- Avoid turning on slopes. If you must turn, turn slowly and gradually downhill, if possible.
- Do not mow near drop-offs, ditches, or embankments. The machine could suddenly turn over if a wheel goes over the edge of a cliff or ditch, or if an edge caves in.
- Do not mow on wet grass. Reduced traction could cause sliding.
- Do not use a grass catcher on steep slopes. Heavy grass bags could cause loss of control of the machine.
- Do not mow up and down slopes.

Service

- Never store the machine or fuel container inside where there is an open flame, such as near a water heater or furnace.
- Keep nuts and bolts tight, especially the blade attachment bolts. Keep equipment in good condition.

- Never tamper with safety devices. Check safety systems for proper operation before each use.
- Use only genuine replacement parts to ensure that original standards are maintained.
- Check brake operation frequently. Adjust and service as required.
- Hydraulic fluid escaping under pressure can penetrate the skin and cause injury. Use cardboard or paper to find hydraulic leaks. Never use your hands.

Slope Chart

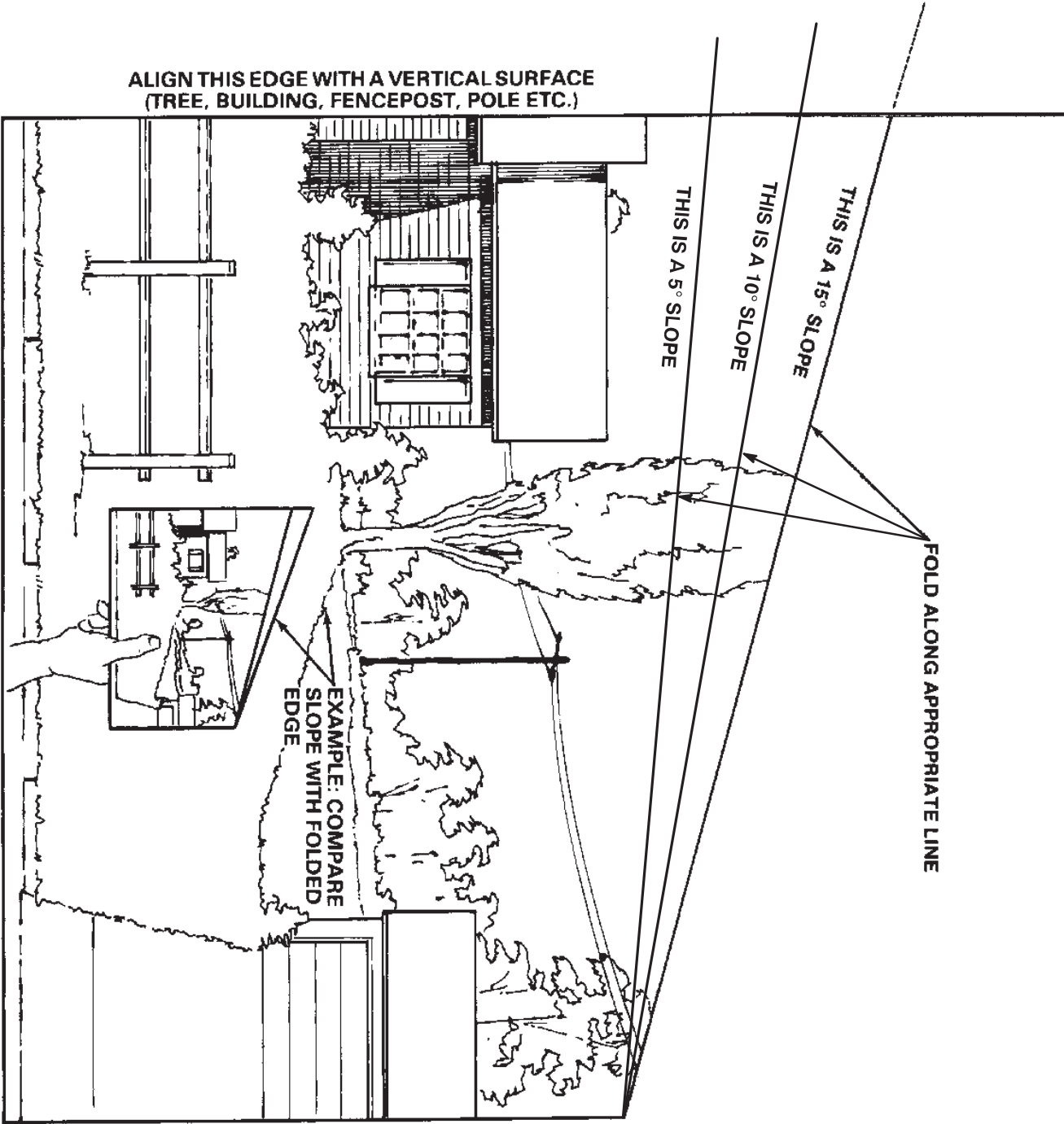

Safety and Instruction Decals



Safety decals and instructions are easily visible to the operator and are located near any area of potential danger. Replace any decal that is damaged or lost.



1-523552



43-8480



66-1340



67-5360



68-8340



82-4590



93-1122



95-2814



98-0776



98-4387

1. Warning—wear hearing protection.

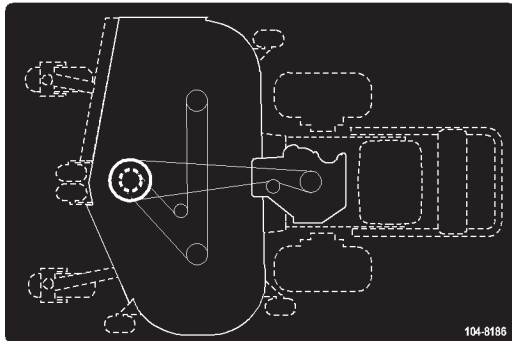

104-8186



104-2838



104-8569



105-4110



105-4146

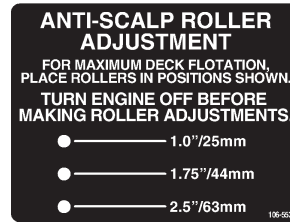

106-5532



106-0699

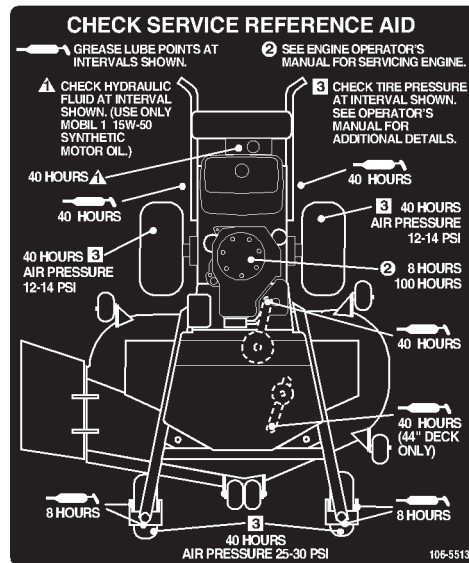

106-5513

105-4109

HEIGHT OF CUT PINS ADJUSTMENT

- POSITION ALL PINS IN SAME HEIGHT OF CUT HOLE
- TURN ENGINE OFF BEFORE ADJUSTING DECK CUTTING HEIGHT
- NOTE: HEIGHT IS BASED ON USING ONE FRONT SPACER AND ONE REAR SPACER ON ADJUSTMENT PINS
- ADD ONE ADDITIONAL SPACER TO INCREASE CUTTING HEIGHT 1/4 INCH
- NOTE: REFER TO OPERATOR'S MANUAL FOR ADDITIONAL HEIGHT OF CUT ADJUSTMENT.

106-0635

106-0635

DANGER

AVOID SERIOUS INJURY or DEATH:

- DO NOT MOW WHEN CHILDREN OR OTHERS ARE AROUND.
- DO NOT ALLOW OPERATION OF THE MACHINE BY UNTRAINED PERSONNEL.
- KEEP SAFETY DEVICES (GUARDS, SHIELDS, ETC.) IN PLACE & WORKING.
- REMOVE OBJECTS THAT COULD BE THROWN BY THE BLADE.
- READ THE OPERATOR'S MANUAL FOR REPLACEMENT MANUAL, SEND MODEL AND SERIAL NUMBER TO:
THE TORO CO.
8111 LINDALE AVE. S.
BLOOMINGTON, MN 55420-1196

106-5515

106-5515

- | | | | |
|---|---|--|---------------------------------|
| 1. Keep bystanders a safe distance from the machine. | 4. Stop the engine and pick up debris before operating. | 9. To drive forward, move the controls as illustrated. | 12. Power take-off (PTO) |
| 2. Do not allow bystanders to be hit by thrown objects. | 5. Cutting of hand or foot, mower. | 10. To place the machine in neutral, move the controls as illustrated. | 13. Fast |
| 3. Do not operate the mower with the deflector up or removed. | 6. Engine—stop | 11. To drive in reverse, move the controls as illustrated. | 14. Continuous variable setting |
| | 7. Engine—run | | 15. Slow |
| | 8. Hour meter | | 16. Neutral |

PROLINE **TORO**

106-5501

106-5501

- | | | | |
|----------|---------|--------------------------------|---------|
| 1. Choke | 2. Fast | 3. Continuous variable setting | 4. Slow |
|----------|---------|--------------------------------|---------|

Gasoline and Oil

Recommended Gasoline

Use UNLEADED Regular Gasoline suitable for automotive use (85 pump octane minimum). Leaded regular gasoline may be used if unleaded regular is not available.

Important Never use methanol, gasoline containing methanol, or gasohol containing more than 10% ethanol because the fuel system could be damaged. Do not mix oil with gasoline.



Danger



In certain conditions, gasoline is extremely flammable and highly explosive. A fire or explosion from gasoline can burn you and others and can damage property.

- Fill the fuel tank outdoors, in an open area, when the engine is cold. Wipe up any gasoline that spills.
- Never fill the fuel tank inside an enclosed trailer.
- Do not fill the fuel tank completely full. Add gasoline to the fuel tank until the level is 1/4 to 1/2 inch (6 to 13 mm) below the bottom of the filler neck. This empty space in the tank allows gasoline to expand.
- Never smoke when handling gasoline, and stay away from an open flame or where gasoline fumes may be ignited by a spark.
- Store gasoline in an approved container and keep it out of the reach of children. Never buy more than a 30-day supply of gasoline.
- Always place gasoline containers on the ground away from your vehicle before filling.
- Do not fill gasoline containers inside a vehicle or on a truck or trailer bed because interior carpets or plastic truck bed liners may insulate the container and slow the loss of any static charge.
- When practical, remove gas-powered equipment from the truck or trailer and refuel the equipment with its wheels on the ground.
- If this is not possible, then refuel such equipment on a truck or trailer from a portable container, rather than from a gasoline dispenser nozzle.
- If a gasoline dispenser nozzle must be used, keep the nozzle in contact with the rim of the fuel tank or container opening at all times until fueling is complete.



Warning



Gasoline is harmful or fatal if swallowed. Long-term exposure to vapors can cause serious injury and illness.

- Avoid prolonged breathing of vapors.
- Keep face away from nozzle and gas tank or conditioner opening.
- Keep gas away from eyes and skin.

Using Stabilizer/Conditioner

Use a fuel stabilizer/conditioner in the machine to provide the following benefits:

- Keeps gasoline fresh during storage of 90 days or less. For longer storage it is recommended that the fuel tank be drained.
- Cleans the engine while it runs
- Eliminates gum-like varnish buildup in the fuel system, which causes hard starting

Important Do not use fuel additives containing methanol or ethanol.

Add the correct amount of gas stabilizer/conditioner to the gas.

Note: A fuel stabilizer/conditioner is most effective when mixed with fresh gasoline. To minimize the chance of varnish deposits in the fuel system, use fuel stabilizer at all times.

Filling the Fuel Tank

1. Shut the engine off and set the parking brake.
2. Clean around fuel tank cap and remove the cap. Add unleaded regular gasoline to fuel tank, until the level is 1/4 to 1/2 inch below the bottom of the filler neck. This space in the tank allows gasoline to expand. Do not fill the fuel tank completely full.
3. Install fuel tank cap securely. Wipe up any gasoline that may have spilled.

Check Engine Oil Level

Before you start the engine and use the machine, check the oil level in the engine crankcase; refer to Checking the Engine Oil Level, page 28.

Setup

Note: Determine the left and right sides of the machine from the normal operating position.

Loose Parts

Note: Use the chart below to verify all parts have been shipped.

Step	Description	Qty.	Use
1	Handle assembly	1	Installing the handle assembly
	Flanged bolt 3/8 x 1 inch	2	
	Flanged bolt 3/8 x 1-1/4 inch	2	
	Flange nut 3/8 inch	4	
2	Fuel tank with studs installed	1	Installing the fuel tank
	Bolt, 5/16 x 7/8 inch	2	
	Lock washer, 5/16 inch	2	
	Washer, 5/16 inch	4	
	Spring	2	
	Hose clamp	1	
3	E-ring	2	Installing the control rods
4	Cotter pin	1	Installing the speed control rod
	Washer	1	
5	Hairpin cotter pin	2	Installing the hairpin cotter pins and washers
6	No parts needed		Checking the tire pressure
7	No parts needed	1	Checking the hydraulic fluid and engine oil
8	No parts needed	1	Setting up the hydro control linkage
9	Oil drain hose	1	Use for draining engine oil
	Operator's Manual	1	Read before operating machine
	Engine Operator's Manual	1	Read before operating machine
	Parts Catalog	1	
	Registration card	1	Fill out and return to Toro

Step 1

Parts needed for this step:

- 1 Handle assembly
- 2 Flange bolts, 3/8 x 1 inch
- 2 Flange bolts, 3/8 x 1-1/4 inch
- 4 Flange nuts, 3/8 inch

Installing the Handle Assembly

1. Align handle with upper mounting holes in rear frame (Fig. 2).
2. Secure the handle at each upper mounting hole with a flange bolt (3/8 x 1-1/4 inch) and flange nut (Fig. 2).
3. Select the low position for the lower mounting hole (Fig. 2).
4. Secure the handle at each lower mounting hole with a flange bolt (3/8 x 1 inch) and flange nut (Fig. 2).

Note: The handle position can be adjusted to match the operator's height preference.

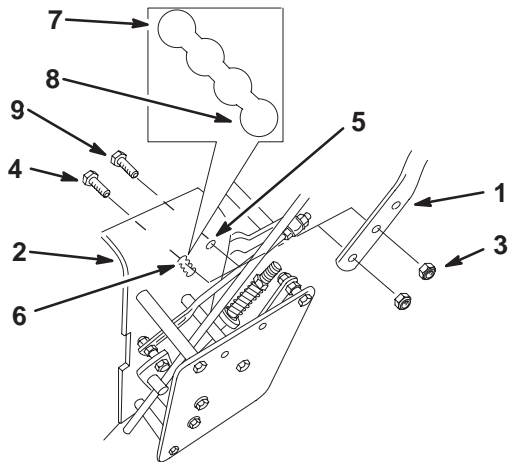

Figure 2

- | | |
|------------------------------|----------------------------------|
| 1. Handle assembly | 6. Lower mounting holes |
| 2. Rear frame | 7. Low position |
| 3. Flange nut, 3/8 inch | 8. High position |
| 4. Flange bolt, 3/8 x 1 inch | 9. Flange bolt, 3/8 x 1-1/4 inch |
| 5. Upper mounting hole | |

Note: Handle assembly must be installed before fuel tank is installed.

Step 2

Parts needed for this step:

- 1 Fuel tank with studs installed
- 2 Bolts, 5/16 x 7/8 inch
- 2 Lock washers, 5/16 inch
- 2 Flat washers, 5/16 inch
- 2 Springs
- 1 Hose clamp

Installing the Fuel Tank

1. Align the fuel tank with the top of the rear frame (Fig. 4).
2. Push the fuel line through the grommet and hole in the hydraulic oil filter bracket (Fig. 4).
3. Push the fuel line onto the fuel tank connection and secure it with the hose clamp that is on the fuel line (Fig. 3).

Note: To ease assembly of the fuel line to fuel tank connection, apply a light lubricant, such as WD 40, to the end of the fuel line.

Note: Make sure the fuel line and clamp are on as shown in Figure 3.

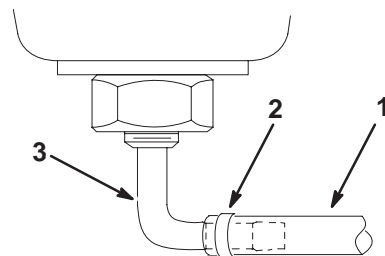

Figure 3

- | | |
|--------------|-------------------------|
| 1. Fuel line | 3. Fuel tank connection |
| 2. Clamp | |

4. Secure the right side of the fuel tank to the rear frame (Fig. 4) with 2 bolts (5/16 x 7/8 inch), lock washers (5/16 inch) and washers (5/16 inch) (Fig. 4).
5. Secure the left side of the fuel tank to the rear frame (Fig. 4) with washers (5/16 inch), springs and locknuts (5/16 inch) (Fig. 4).

Note: Tighten left side of shift lever plate until it is completely tight and then unscrew the locknut one full turn. This will allow the spring to work.

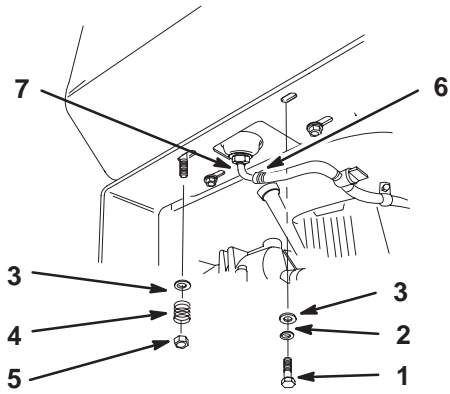

Figure 4

m-6583

- | | |
|---------------------------|-------------------------|
| 1. Bolt, 5/8 x 7/8 inch | 5. Locknut |
| 2. Lock washer, 5/16 inch | 6. Hose clamp |
| 3. Washer, 5/16 inch | 7. Fuel tank connection |
| 4. Spring | |

Step 3

Parts needed for this step:

- 2 E-clips

Installing the Control Rods

1. For a starting point, make sure the rod fittings are threaded approximately 2-1/2 inches (63 mm) onto the control rods (Fig. 5).
2. Install the rod fittings into the and secure them with E-rings (Fig. 5).

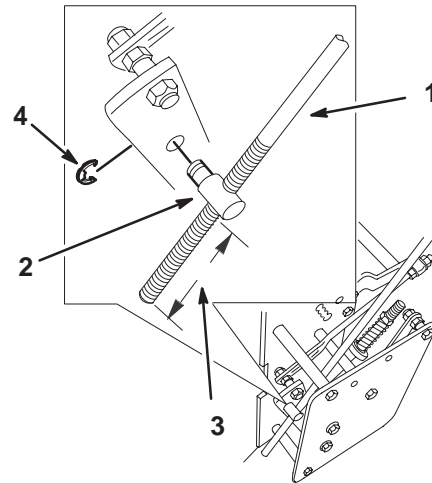

m-6601

Figure 5

- | | |
|----------------|-------------------------------------|
| 1. Control rod | 3. 2-1/2 inch (63.5 mm) from bottom |
| 2. Rod fitting | 4. E-ring |

Step
4

Parts needed for this step:

- 1 Cotter pin
- 1 Washer

Installing the Speed Control Rod

1. Install the swivel into the speed control crank and secure it with a washer and cotter pin (Fig. 6).

Note: If necessary move the speed control lever until the swivel will go into the speed control crank.

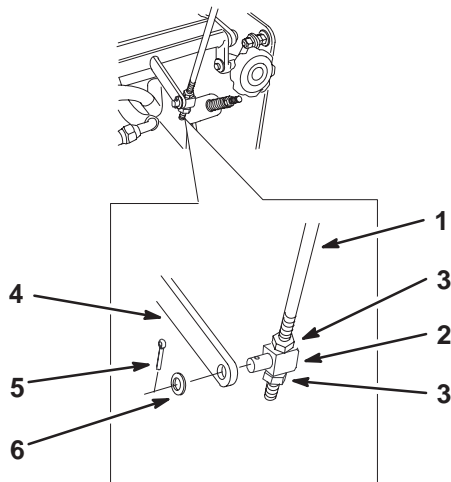

Figure 6

- | | |
|----------------------|------------------------|
| 1. Speed control rod | 4. Speed control crank |
| 2. Swivel | 5. Cotter pin |
| 3. Nut | 6. Washer |

Step
5

Parts needed for this step:

- 2 Hairpin cotter pins

Installing the Hairpin Cotter Pins and Washers

Unused height-of-cut spacers may be stored on posts and retained by a hairpin cotter.

1. On the opposite side of the muffler, install unused washers and hairpin cotter pins into front and rear height-of-cut pins (Fig. 7).

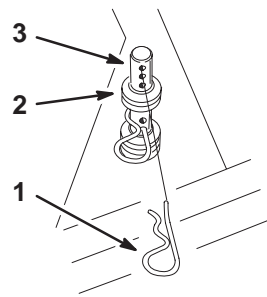

Figure 7

- | | |
|-------------------|-----------------------|
| 1. Hairpin cotter | 3. Height-of-cut post |
| 2. Unused spacers | |

Step
6

No parts needed for this step.

Checking the Tire Pressure

Refer to Page 32 for the correct correct tire pressure.

Step 7

No parts needed for this step.

Checking the Hydraulic Fluid and Engine Oil

Check the hydraulic fluid level before the engine is first started.

Refer to Checking the Hydraulic Fluid on page 33.

Check the engine oil level before the engine is first started.

Refer to Checking the Engine Oil Level on page 28.

Step 8

No parts needed for this step.

Setting Up the Hydro Linkage

Check the following adjustments when the machine is first set up and adjust only as needed. Do them in the order that they are listed here.

Checking the Speed Control Linkage

Refer to Adjusting the Speed Control Linkage on page 35.

Checking the Temporary Neutral Stud Adjustment

Refer to Temporary Neutral Stud Adjustment on page 36.

Checking the Hydro Control Linkages

Refer to Adjusting the Hydro Control Linkages on page 36.

Checking the Neutral Stud

Refer to Adjusting the Neutral Stud on page 38.

Checking the Control Rods

Refer to Adjusting the Control Rods on page 39.

Checking the Tracking

Refer to Adjusting the Tracking on page 40.

Operation

Note: Determine the left and right sides of the machine from the normal operating position.

Think Safety First

Carefully read all the safety instructions and decals in the safety section. Knowing this information could help you, your family, pets or bystanders avoid injury.

The use of protective equipment for eyes, hearing, feet and head is recommended.

⚠**Caution**⚠

This machine produces sound levels in excess of 85dBA at the operator's ear and can cause hearing loss through extended periods of exposure.

Wear hearing protection when operating this machine.

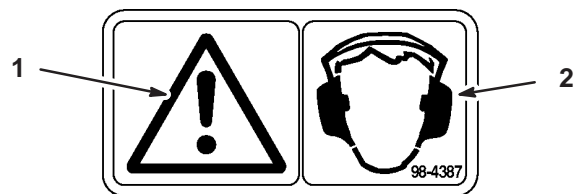

Figure 8

1. Caution
2. Wear hearing protection

Controls

Become familiar with all the controls (Fig. 9) before you start the engine and operate the machine.

Throttle control – The throttle control has three positions: Choke, Fast and Slow.

Operator Presence Control (OPC) levers – OPC levers are used in conjunction with deck engagement switch (PTO) to release blade brake and engage clutch to drive mower blades. Release OPC levers to disengage mower blades.

Blade control switch (PTO) – Pull switch used in conjunction with OPC levers to release blade brake and engage clutch to drive mower blades.

Speed control lever – This machine has a variable speed control with a neutral position. This controls and limits how fast the machine will travel.

Drive levers – Move the speed control lever to the desired forward speed, slowly release the drive levers to engage forward traction operation, and squeeze the drive levers to neutral or reverse. When moving forward, squeeze the right drive lever to turn right and the left drive lever to turn left.

Neutral lock – Squeeze drive levers back and rotate locks to the rear for neutral lock.

Ignition Switch – Key switch is used in conjunction with recoil starter. Switch has two positions: Run and Off.

Recoil Starter – Pull recoil starter handle to start engine.

Fuel Shut-off Valve – (Under fuel tank) Close fuel shut-off valve when transporting or storing mower.

Hour Meter – Shows total hours that machine has been operated. This operates only when the mower blades are operating.

The hour meter will flash 3 hours before and after a service interval.

The service intervals are set for the first 8 hours, every 100 hours there after and every 400 hours.

Perform any recommended maintenance at these intervals. Refer to Recommended Maintenance Schedule on page 26.

Note: Make sure maintenance is done at all recommended intervals shown in the Recommended Maintenance Schedule on page 26.

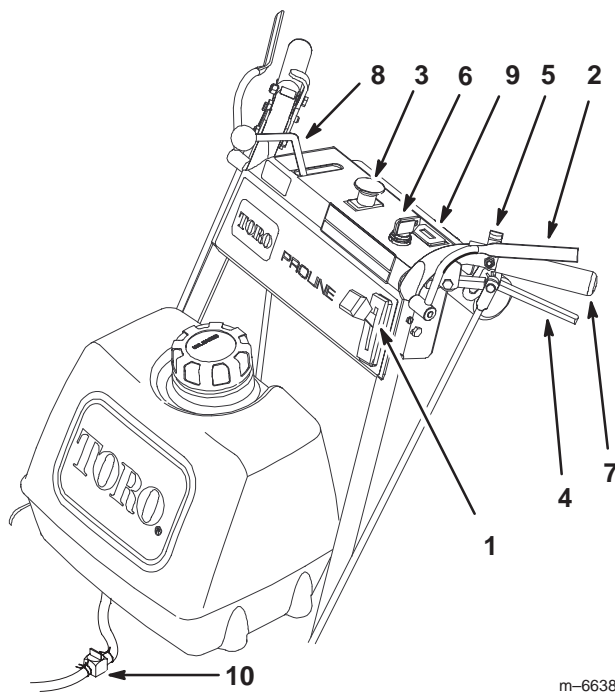

m-6638

Figure 9

- | | |
|---|-------------------------|
| 1. Throttle control | 5. Neutral lock |
| 2. Operator Presence Control levers (OPC) | 6. Ignition switch |
| 3. Blade control switch (PTO) | 7. Handle |
| 4. Drive lever | 8. Speed control lever |
| | 9. Hour meter |
| | 10. Fuel shut-off valve |

Starting and Stopping the Engine

Starting

1. Make sure spark plug wire(s) are installed on spark plug(s) and fuel valve is open.
2. Move the speed control lever to neutral, set the neutral locks and turn ignition key to Run.
3. Move the throttle control to the Choke position before starting a cold engine.

Note: A warm or hot engine usually does not require any choking. To start a warm engine, move throttle control to the Fast position.

4. Grasp recoil starter handle firmly and pull out until positive engagement results; then pull handle vigorously to start engine and allow rope to recoil slowly.

Important Do not pull recoil rope to its limit or let go of the starter handle when rope is pulled out because rope may break or recoil assembly may be damaged.

Stopping

1. Move the throttle lever to the Slow position (Fig. 10).
2. Squeeze the drive levers to the Neutral position and set the neutral locks.
3. Let the engine idle for 30 to 60 seconds before turning the ignition key Off.
4. Turn the ignition key to Off (Fig. 10).

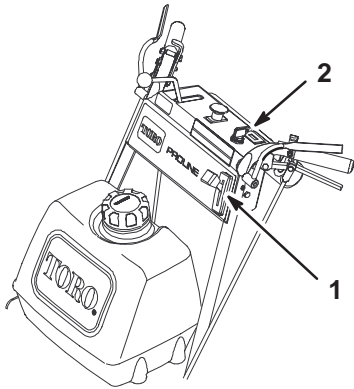

Figure 10

m-6638

1. Throttle lever
2. Ignition key

Important Make sure fuel shut off valve is closed before transporting or storing machine, as fuel leakage may occur. Before storing machine, pull wire off spark plug(s) to prevent possibility of accidental starting.

Operating Neutral Locks

Always set the neutral lock when you stop the machine. Set the parking brake if it is left unattended.

Setting the Neutral Lock

1. Squeeze the drive levers back to neutral position (Fig. 11).
2. Place thumbs on the upper part of the neutral locks and rotate them back (Fig. 11).

Releasing the Neutral Lock

1. Squeeze the drive levers back to the grip slightly (Fig. 11).

2. Place thumbs on the upper part of the neutral locks and rotate them forward until in forward slot (Fig. 11).

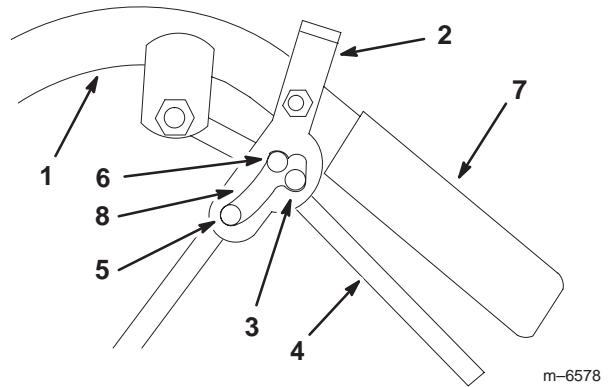

m-6578

Figure 11

- | | |
|---------------------|-----------------------|
| 1. Handle | 5. Full speed forward |
| 2. Neutral lock | 6. Reverse position |
| 3. Neutral position | 7. Grip |
| 4. Drive lever | 8. Forward slot |

Operating the Parking Brake

Always set the parking brake when you stop the machine or leave it unattended. Before each use, check brake for proper operation.

If the parking brake does not hold securely, an adjustment is required. Refer to Servicing the Brake on page 40.



Caution



Children or bystanders may be injured if they move or attempt to operate the machine while it is unattended.

Always remove the ignition key and set the parking brake when leaving the machine unattended, even if just for a few minutes.

Setting the Parking Brake

1. Pull the brake handle rearward (Fig. 11).

Releasing the Parking Brake

1. Push the brake handle forward (Fig. 11).

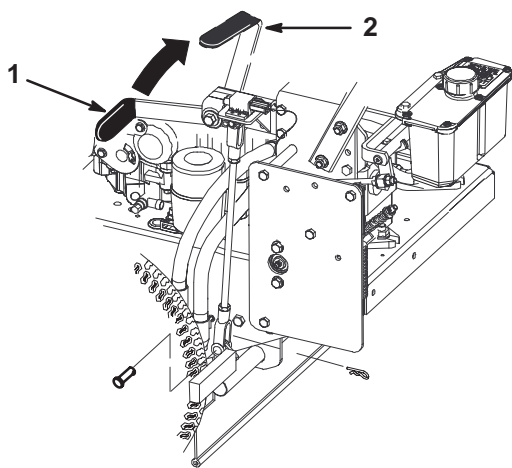

m-6614

Figure 12

1. Parking brake lever (released position)
2. Parking brake lever (engaged position)

Operating Mower Blade Control (PTO)

The blade control switch (PTO) in conjunction with the Operator Presence Control (OPC) levers engage and disengage power to the electric clutch and mower blades.

Engaging the Mower Blades (PTO)

1. To engage the blade, press the Operator Presence Control (OPC) levers against handle grips (Fig. 13).
2. Pull blade switch (PTO) up and release while holding the OPC levers against handle grip.

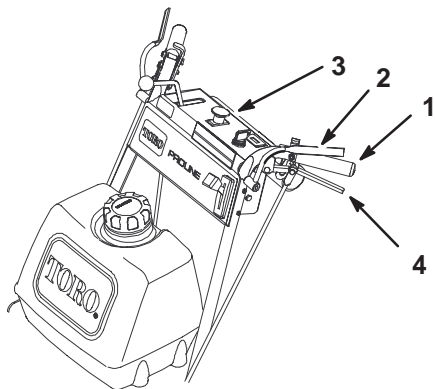

m-6638

Figure 13

1. Handle
2. Operator Presence Control levers (OPC)
3. Blade control switch (PTO)
4. Drive Lever

Disengaging the Mower Blades (PTO)

1. Release Operator Presence Control (OPC) levers to disengage blades (Fig. 13).

The Safety Interlock System



Caution



If safety interlock switches are disconnected or damaged the machine could operate unexpectedly causing personal injury.

- Do not tamper with the interlock switches.
- Check the operation of the interlock switches daily and replace any damaged switches before operating the machine.

Understanding the Safety Interlock System

The safety interlock system is designed to prevent the mower from starting unless:

- The blade control switch (PTO) is off.
- The speed control lever is in neutral.

The safety interlock system is designed to kill the engine when:

- The Operator Presence Control (OPC) levers are released while the speed control is out of neutral position and/or the mower is engaged.
- The speed control lever is shifted out of neutral without holding OPC levers.
- The blade control switch (PTO) is pulled on without holding the OPC levers.

Testing the Safety Interlock System

Test the safety interlock system before you use the machine each time. If the safety system does not operate as described, have an Authorized Service Dealer repair the safety system immediately.

1. Set the neutral locks and place speed control lever in neutral. Start the engine; refer to Starting and Stopping the Engine, page 18.
2. Without holding the Operator Presence Control (OPC) levers, pull the blade control switch (PTO) up. **The engine should kill.**
3. With engine running, hold down the OPC levers. Pull the blade control switch (PTO) up. The clutch should engage and **the mower blades begin rotating.**
4. Release the OPC levers. **The engine should kill.**

5. With the engine running, move the speed control lever forward. Release the OPC levers. **The engine should kill.**
6. If all the above conditions are not met have an Authorized Service Dealer repair the safety system immediately.

Driving Forward or Backward

The throttle control regulates the engine speed as measured in rpm (revolutions per minute). Place the throttle control in the Fast position for best performance.

Forward

1. Release the parking brake; refer to Releasing the Parking Brake, page 19.
2. To go forward, move the speed control lever to desired speed.
3. Release the neutral lock. Refer to Releasing the Neutral Lock on page 19.
4. Slowly release the drive levers to move forward (Fig. 14).

To go straight, release drive levers equally (Fig. 14).

To turn, squeeze the drive lever on the side and direction you want to turn (Fig. 14).

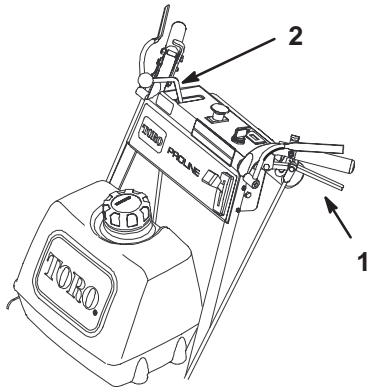

Figure 14

m-6638

1. Drive lever
2. Speed control lever

Backward

1. Release the neutral lock. Refer to Releasing the Neutral Locks on page 19.
2. Slowly squeeze the drive levers back to the grips together to move rearward (Fig. 14).

Bringing Machine to Neutral Position

Always set the neutral lock when you stop the machine. Set the parking brake if it is left unattended.

1. Squeeze the drive levers back toward the grips to neutral position.
2. Set the neutral locks. Refer to Operating Neutral Locks on page 19.
3. Move speed control lever to neutral position.

Stopping the Machine

1. To stop the machine, squeeze the drive levers to the neutral position.
2. Rotate the neutral locks into the neutral lock position. Refer to Operating Neutral Locks on page 19.
3. Move the speed control lever into neutral.
4. Turn the ignition key to Off.
5. Set the parking brake if it is left unattended.

Note: Remember to remove the key from the ignition switch if you leave the machine.



Caution



Children or bystanders may be injured if they move or attempt to operate the machine while it is unattended.

Always remove the ignition key and set the parking brake when leaving the machine unattended, even if just for a few minutes.

Pushing the Machine by Hand

The by-pass valve allows the machine to be pushed by hand with the engine not running for easier servicing.

Important Always push the machine by hand. Never tow the machine because hydraulic damage may occur.

To Push the Machine

1. Move the speed control lever to neutral.
2. Disengage the power take off (PTO) by releasing the OPC levers and turn the ignition key to Off.

- Open the by-pass valves, by turning them counter clockwise 1 to 2 turns, to push the machine. This allows hydraulic fluid to by-pass the pump and the wheels to turn (Fig. 15).

Important Rotate by-pass valve a maximum of 2 turns so the valve does not come out of the body causing fluid to run out.

To Operate the Machine

To operate the machine, ensure the by-pass valves are closed.

Note: The machine will not drive unless by-pass valves are closed.

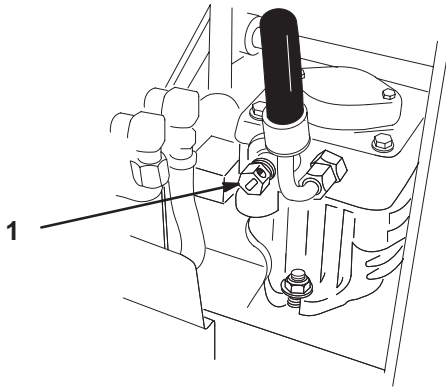

m-6576

Figure 15

- By-pass valve

Transporting Machines

Use a heavy-duty trailer or truck to transport the machine. Ensure that the trailer or truck has all necessary lighting and marking as required by law. Please carefully read all the safety instructions. Knowing this information could help you, your family, pets or bystanders avoid injury.

To transport the machine:

- Set the parking brake.
- Securely fasten the machine to the trailer or truck with straps, chains, cable, or ropes.
- Secure a trailer to towing vehicle with safety chains.

Side Discharge or Mulch Grass

This mower has a hinged grass deflector that disperses clippings to the side and down toward the turf.



Danger



Without the grass deflector, discharge cover, or complete grass catcher assembly mounted in place, you and others are exposed to blade contact and thrown debris. Contact with rotating mower blade(s) and thrown debris will cause injury or death.

- Never remove the grass deflector from the mower because the grass deflector routes material down toward the turf. If the grass deflector is ever damaged, replace it immediately.
- Never put your hands or feet under the mower.
- Never try to clear discharge area or mower blades unless you release the bail and the power take off (PTO) is off. Rotate the ignition key to Off. Also remove the key and pull the wire off the spark plug(s).

Adjusting the Height-of-Cut

The height-of-cut can be adjusted from 1 to 4-1/2 inch (25 to 115 mm) in 1/4 inch (6 mm) increments.

Adjustment is done by relocating four hairpin cotter pins in different hole location and by adding or removing spacers.

Note: Rear height-of-cut pins need at least one spacer or damage can occur to bushing if none are used.

- To adjust, remove hairpin cotter from height-of-cut post (Fig. 16).
- Select hole in height-of-cut post corresponding to the height-of-cut desired (Fig. 16).
- Lift on side of deck and remove hairpin cotter (Fig. 16).
- Add or remove spacers if needed and then align holes and insert hairpin cotter (Fig. 16).

Note: Spare height-of-cut spacers may be stored on posts and retained by a hairpin cotter.

Important All four hairpin cotter pins must be in the same hole location and with the correct number of spacers for a level cut.

HEIGHT OF CUT PINS ADJUSTMENT

- POSITION ALL PINS IN SAME HEIGHT OF CUT HOLE
- TURN ENGINE OFF BEFORE ADJUSTING DECK CUTTING HEIGHT
- NOTE: HEIGHT IS BASED ON USING ONE FRONT SPACER AND ONE REAR SPACER ON ADJUSTMENT PINS
- ADD ONE ADDITIONAL SPACER TO INCREASE CUTTING HEIGHT 1/4 INCH
- NOTE: REFER TO OPERATOR'S MANUAL FOR ADDITIONAL HEIGHT OF CUT ADJUSTMENT.

106-0635

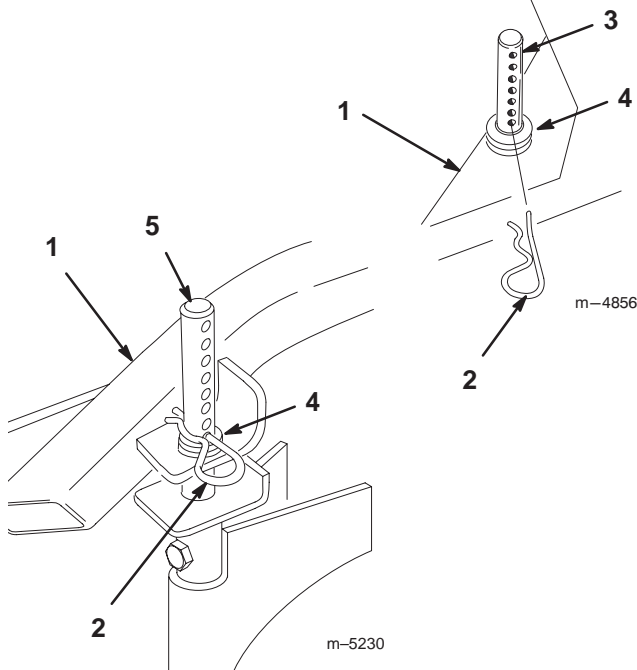

Figure 16

- | | |
|-----------------------------|----------------------------|
| 1. Carrier Frame | 4. Spacers |
| 2. Hairpin Cotter | 5. Back height-of-cut post |
| 3. Front height-of-cut post | |

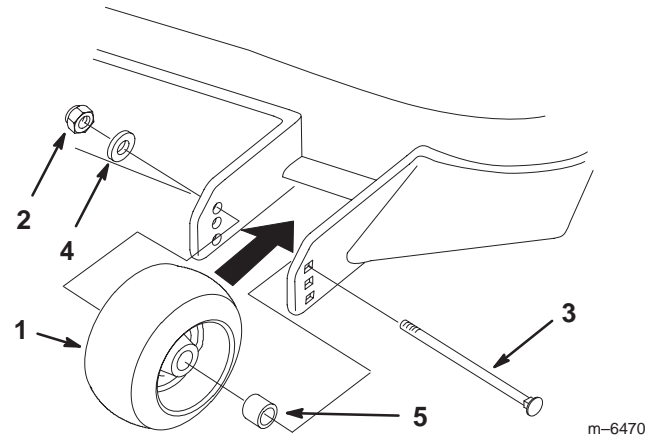

Figure 17

- | | |
|---------------|-----------|
| 1. Gage wheel | 4. Washer |
| 2. Nut | 5. Spacer |
| 3. Bolt | |

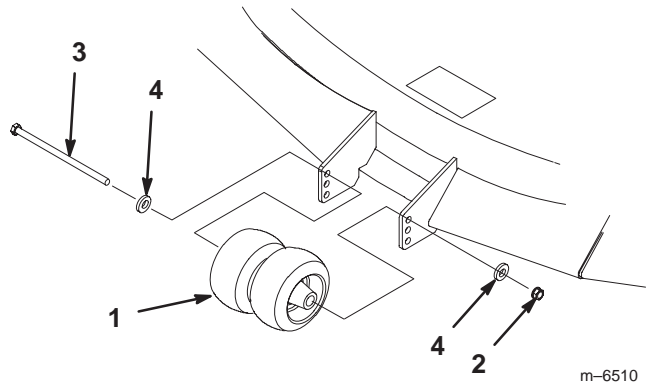

Figure 18

- | | |
|----------------------------------|-----------|
| 1. Center Gage Wheels and Spacer | 3. Bolt |
| 2. Nut | 4. Washer |

Adjusting the Gage Wheels

The gage wheels need to be adjusted in the proper hole location for each height-of-cut position. There needs to be 3/8 inch (10 mm) minimum clearance above the ground.

1. After adjusting height-of-cut, check the gage wheels so that there is a minimum of 3/8 inch (10 mm) clearance above the ground (Figures 17 and 18).
2. If adjustment is needed, remove the bolt, washer(s) and nut (Figures 17 and 18).
3. Select a hole position so the gage wheels are a minimum of 3/8 inch (10 mm) off the ground (Figures 17 and 18).
4. Install the bolt, washer(s) and nut (Figures 17 and 18).

Adjusting the Handle Height

The handle position can be adjusted to match the operator's height preference.

Note:

1. Remove the hairpin cotter pin and clevis pin from the drive lever and neutral lock (Fig. 19).

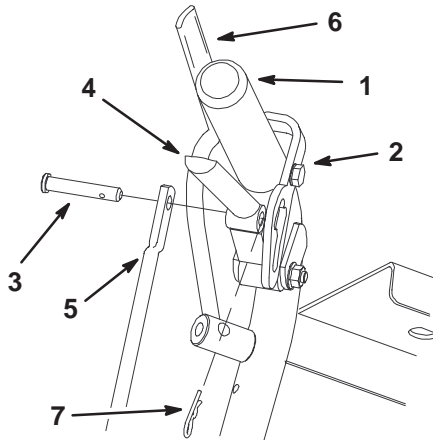

m-6639

Figure 19

- | | |
|----------------------|--|
| 1. Left handle shown | 5. Control rod |
| 2. Neutral lock | 6. Operator Presence Control lever (OPC) |
| 3. Clevis pin | 7. Hairpin cotter |
| 4. Drive lever | |

2. Loosen the nuts holding the swivel connected to the speed control crank (Fig. 20).

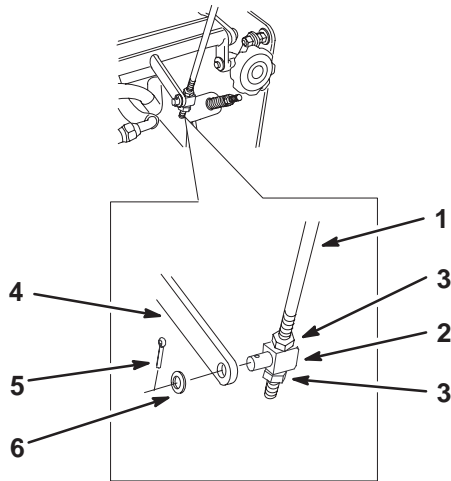

m-6602

Figure 20

- | | |
|----------------------|------------------------|
| 1. Speed control rod | 4. Speed control crank |
| 2. Swivel | 5. Cotter pin |
| 3. Nut | 6. Washer |

3. Loosen the upper flange bolts (3/8 x 1 inch) and flange nut securing handle to rear frame (Fig. 21).

4. Remove the lower flange bolts (3/8 x 1 inch) and flange nuts securing handle to rear frame (Fig. 21).
5. Pivot handle to desired operating position and install lower flange bolts (3/8 x 1 inch) and flange nuts into mounting holes. Tighten all flange bolts.

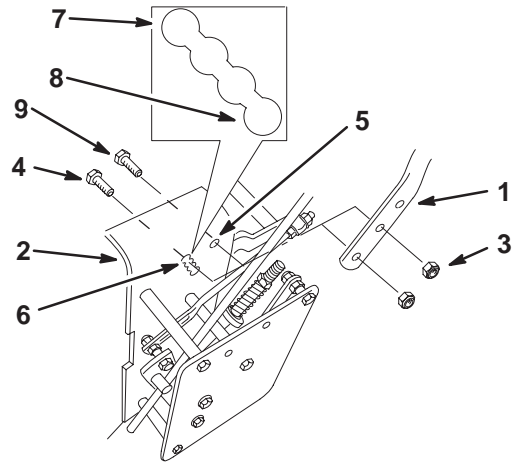

m-6600

Figure 21

- | | |
|------------------------------|----------------------------------|
| 1. Handle assembly | 6. Lower mounting holes |
| 2. Rear frame | 7. Low position |
| 3. Flange nut, 3/8 inch | 8. High position |
| 4. Flange bolt, 3/8 x 1 inch | 9. Flange bolt, 3/8 x 1-1/4 inch |
| 5. Upper mounting hole | |

6. Adjust the swivel on the speed control rod and tighten the nuts against the swivel (Fig. 20).
7. Adjust the control rod length by rotating the control rod in the rod fitting (Fig. 5).
8. Install hairpin cotter between drive levers and neutral locks and into clevis pins (Fig. 19).

Note: Make sure the clevis pins are inserted into the neutral locks.

9. Perform the hydraulic linkage adjustments when the handle height is changed. Refer Hydraulic Linkage Adjustments on page 35.

Using the Mid-Size Weight Kit

A weight kit is available for this machine. This kit is optional and can be obtained from an Authorized Service Dealer

- The weight kit mounted in the **front** position is **required** when a Tru-Trak[®] Sulky is installed.
- The weight kit mounted in the **back** position is **optional** when a Tru-Trak[®] Sulky is not installed (Fig. 22).
- Installing this weight kit can improve performance on slopes without the Tru-Trak[®] Sulky.

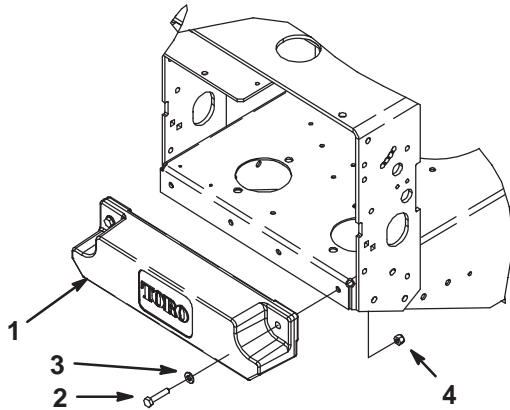

Figure 22

- | | |
|------------------------------------|-----------|
| 1. Weight mounted in rear position | 3. Washer |
| 2. Capscrew | 4. Nut |
-

Maintenance

Note: Determine the left and right sides of the machine from the normal operating position.

Recommended Maintenance Schedule

Maintenance Service Interval	Maintenance Procedure
Each Use	<ul style="list-style-type: none"> • Engine Oil—check level • Safety System—check • Brake—check • Engine—clean outside • Mower Housing—clean
After first 8 Hours	<ul style="list-style-type: none"> • Engine Oil—change • Hydraulic Oil—check
8 Hours	<ul style="list-style-type: none"> • Mower Housing—clean • Caster Wheels—grease • Caster Pivot—grease • Cutting Blades—check
25 Hours	<ul style="list-style-type: none"> • Foam Air Cleaner—clean¹
40 Hours	<ul style="list-style-type: none"> • Tires—check pressure • PTO Belt Idler Arm—grease • Hydraulic Oil—check
50 Hours	<ul style="list-style-type: none"> • Belts—check • Paper Air Cleaner—clean¹
100 Hours	<ul style="list-style-type: none"> • Oil—change¹ • Spark Plug(s)—check • Electric Clutch—adjust • Engine—clean outside • Hydraulic lines—check
After first 200 Hours	<ul style="list-style-type: none"> • Hydraulic oil filter—change
200 Hours	<ul style="list-style-type: none"> • Fuel Filter—replace • Engine Oil Filter—change (200 hours or every other oil change) • Paper Air Cleaner—replace
At storage or 400 Hours	<ul style="list-style-type: none"> • Hydraulic oil filter—change • Chipped Surfaces—paint • Perform all maintenance procedures listed above before storage

¹More often in dusty, dirty conditions.

Important Refer to your engine operator's manual for additional maintenance procedures.



Caution



If you leave the key in the ignition switch, someone could accidentally start the engine and seriously injure you or other bystanders.

Remove the key from the ignition and disconnect the spark plug wire from the spark plug(s) before you do any maintenance. Set the wire aside so that it does not accidentally contact the spark plug.

Servicing the Air Cleaner

Service Interval and Specification

Foam Element: Clean and re-oil after every 25 operating hours.

Paper Element: Clean after every 50 operating hours.
Replace after every 200 operating hours.

Note: Service the air cleaner more frequently (every few hours) if operating conditions are extremely dusty or sandy.

Removing the Foam and Paper Elements

1. Disengage the PTO and set the parking brake.
2. Stop the engine, remove the key, and wait for all moving parts to stop before leaving the operating position.
3. Clean around the air cleaner to prevent dirt from getting into the engine and causing damage. Pull out on retaining latches and remove the air cleaner cover (Fig. 23).
4. Unscrew nut and remove the air cleaner assembly (Fig. 23).
5. Carefully pull the foam element off the paper element (Fig. 23).

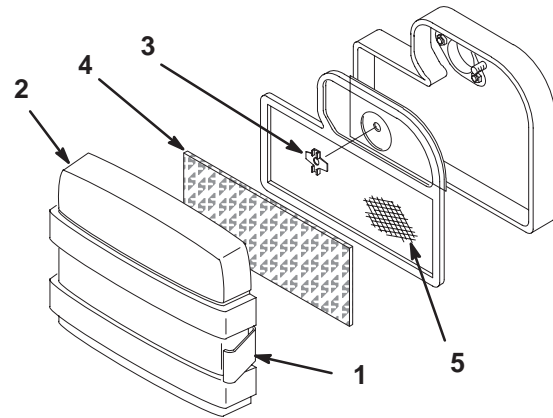

m-4689

Figure 23

- | | |
|--------------------|------------------|
| 1. Retaining latch | 4. Foam element |
| 2. Cover | 5. Paper element |
| 3. Nut | |

Cleaning the Foam Element

1. Wash the foam element in liquid soap and warm water. When the element is clean, rinse it thoroughly.
2. Dry the element by squeezing it in a clean cloth.
3. Put one or two ounces of oil on the element (Fig. 24). Squeeze the element to distribute the oil.

Important Replace the foam element if it is torn or worn.

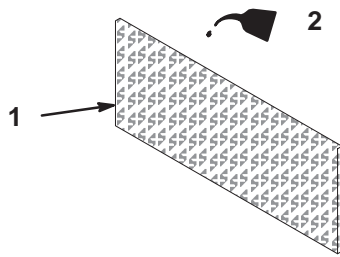

m-4694

Figure 24

1. Foam element 2. Oil

Cleaning the Paper Element

1. Lightly tap the element on a flat surface to remove dust and dirt (Fig. 25).
2. Inspect the element for tears, an oily film, and damage to the rubber seal.

Important Never clean the paper element with pressurized air or liquids, such as solvent, gas, or kerosene. Replace the paper element if it is damaged, defective, or cannot be cleaned thoroughly.

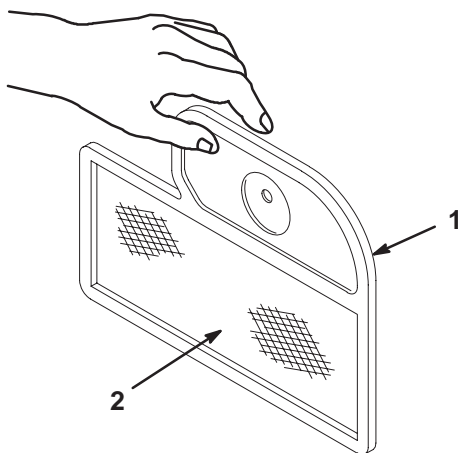

m-4695

Figure 25

1. Paper element 2. Rubber seal

Installing the Foam and Paper Elements

Important To prevent engine damage, always operate the engine with the complete foam and paper air cleaner assembly installed.

1. Carefully place the foam element onto the paper air cleaner element (Fig. 23).

2. Place the air cleaner assembly onto the air cleaner base (Fig. 23). Secure with nut.
3. Install the air cleaner cover and secure latches (Fig. 23).

Service Interval and Specification

Service Interval and Specification

Change oil:

- After the first 8 operating hours.
- After every 100 operating hours.

Note: Change oil more frequently when operating conditions are extremely dusty or sandy.

Oil Type: Detergent oil (API service SE, SF or SG)

Crankcase Capacity: with new filter, 57-1/2 oz. (1.7 l)

without new filter, 51 oz. (1.5 l)

Viscosity: See table below

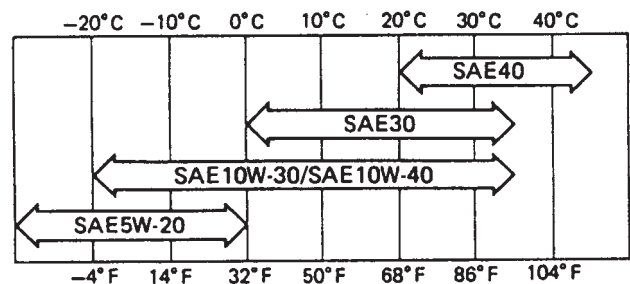

Checking the Engine Oil Level

1. Park the machine on a level surface.
2. Disengage the power take off (PTO), set the parking brake, and turn the ignition key to off. Remove the key.
3. Clean around the oil dipstick (Fig. 26) so dirt cannot fall into the filler hole and damage the engine.
4. Unscrew the oil dipstick and wipe the metal end clean (Fig. 26).
5. Thread the oil dipstick fully onto the filler tube (Fig. 26). Pull the dipstick out and look at the metal end. If oil level is low, slowly pour only enough oil into the filler tube to raise the level to the full mark.

Important Do not overfill the crankcase with oil because the engine may be damaged.

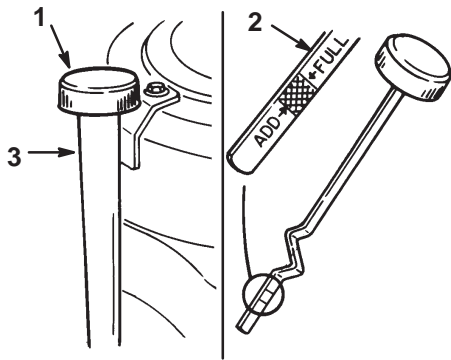

Figure 26

- 1. Oil dipstick
- 2. Metal end
- 3. Filler tube

Changing the Engine Oil

1. Start the engine and let it run five minutes. This warms the oil so it drains better.
2. Park the machine so that the drain side is slightly lower than the opposite side to assure the oil drains completely.
3. Disengage the PTO and set the parking brake.
4. Stop the engine, remove the key, and wait for all moving parts to stop before leaving the operating position.
5. Slide the drain hose over the oil drain valve.
6. Place a pan below the drain hose. Rotate oil drain valve to allow oil to drain (Fig. 27).
7. When oil has drained completely, close the drain valve.
8. Remove the drain hose (Fig. 27).

Note: Dispose of the used oil at a recycling center.

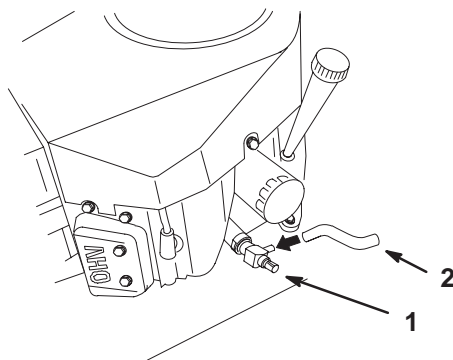

Figure 27

- 1. Oil drain valve
- 2. Drain hose

m-6574

9. Slowly pour approximately 80% of the specified oil, page 28, into the filler tube (Fig. 26).
10. Check the oil level; refer to Checking the Engine Oil Level, page 28.
11. If needed, slowly add additional oil to bring to the **full** mark on dipstick.

Changing the Oil Filter

Service Interval and Specification

Replace the oil filter every 200 hours or every other oil change.

Note: Change oil filter more frequently when operating conditions are extremely dusty or sandy.

1. Drain the oil from the engine; refer to Changing the Engine Oil, page 29.
2. Remove the old filter (Fig. 28).
3. Apply a thin coat of new oil to the rubber gasket on the replacement filter.

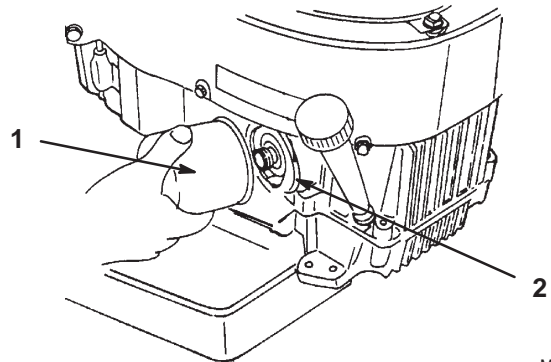

M-4288

Figure 28

- 1. Oil filter
- 2. Adapter

4. Install the replacement oil filter to the filter adapter. Turn the oil filter clockwise until the rubber gasket contacts the filter adapter, then tighten the filter an additional 3/4 turn (Fig. 28).
5. Fill the crankcase with the proper type of new oil; refer to Servicing the Engine Oil, page 28.

Servicing the Spark Plug

Service Interval and Specification

Check the spark plug(s) after every 100 operating hours. Make sure the air gap between the center and side electrodes is correct before installing the spark plug. Use a spark plug wrench for removing and installing the spark plug(s) and a gapping tool/feeler gauge to check and adjust the air gap. Install a new spark plug(s) if necessary.

Type: Champion® RCJ8Y or NGK® BPR4ES
Air Gap: 0.030 inch (.75 mm)

Removing the Spark Plug(s)

1. Disengage the PTO and set the parking brake.
2. Stop the engine, remove the key, and wait for all moving parts to stop before leaving the operating position.
3. Pull the wire(s) off the spark plug(s) (Fig. 29). Now clean around the spark plug(s) to prevent dirt from falling into the engine and potentially causing damage.
4. Remove the spark plug(s).

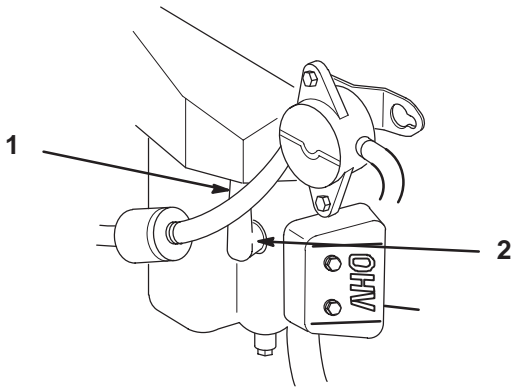

Figure 29

1. Spark plug wire installed
2. Spark plug

M-4294

Checking the Spark Plug

1. Remove spark plug.
2. Look at the center of the spark plug(s) (Fig. 30). If you see light brown or gray on the insulator, the engine is operating properly. A black coating on the insulator usually means the air cleaner is dirty.

Important Never clean the spark plug(s). Always replace the spark plug(s) when it has: a black coating, worn electrodes, an oily film, or cracks.

3. Check the gap between the center and side electrodes (Fig. 30). Bend the side electrode (Fig. 30) if the gap is not correct.

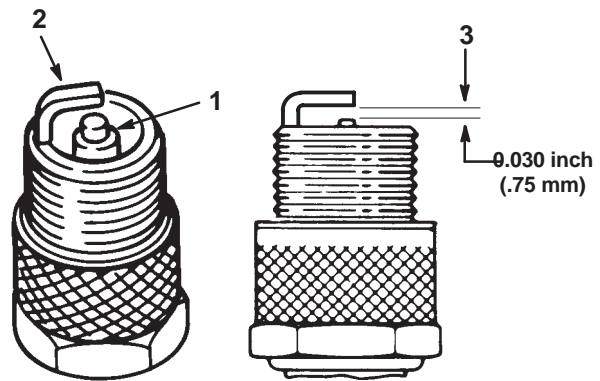

Figure 30

1. Center electrode insulator
2. Side electrode
3. Air gap (not to scale)

Installing the Spark Plug(s)

1. Install the spark plug(s). Make sure the air gap is set correctly.
2. Tighten the spark plug(s) to 11 ft-lb (15 N•m).
3. Push the wire(s) onto the spark plug(s) (Fig. 29).

Fuse Service

Service Interval/Specification

The electrical system is protected by a fuse. It requires no maintenance. If the fuse blows check component or circuit for malfunction or short. To replace fuse pull out on the fuse (Fig. 31) to remove or replace it.

Fuse: F1- 10 amp, blade-type

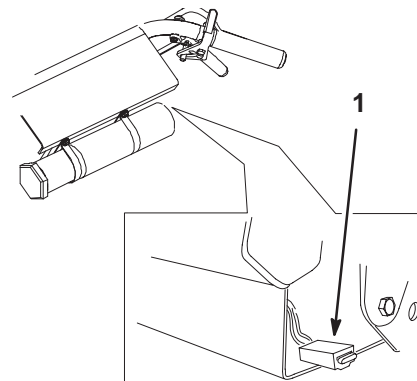

m-5391 m-5390

Figure 31

1. Fuse, 10 amp

and linkage. This will help insure adequate cooling and correct engine speed and will reduce the possibility of overheating and mechanical damage to the engine.

Checking the Tire Pressure

Service Interval/Specification

Maintain the air pressure in the front and rear tires as specified. Check the pressure at the valve stem after every 40 operating hours or monthly, whichever occurs first (Fig. 35). Check the tires when they are cold to get the most accurate pressure reading.

Rear Tire Pressure: 12–14 psi (83–97 kPa)

Caster Tire Pressure: 25–30 psi (172–207 kPa)

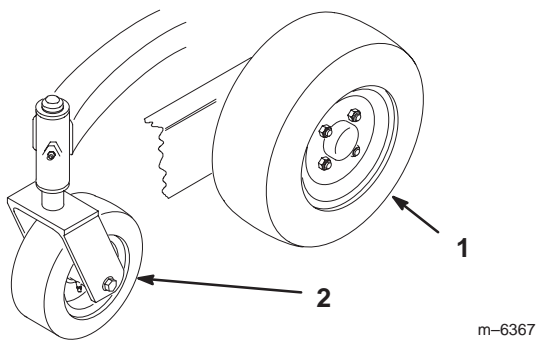

Figure 35

1. Rear Tire
2. Caster tire

Adjusting the Electric Clutch

The clutch is adjustable to ensure proper engagement and proper braking. Check adjustment after every 100 hours of operation.

1. To adjust clutch, tighten or loosen lock nuts on flange studs (Fig. 36).
2. Check adjustment by inserting feeler gauge thru slots next to studs (Fig. 36).
3. The proper disengaged clearance between the clutch plates is 0.012–0.018 inch (0.30–0.45 mm). It will be necessary to check this clearance at each of the three slots to ensure the plates are parallel to each other.

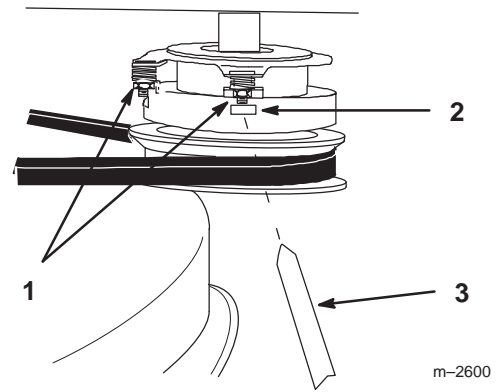

Figure 36

1. Adjusting nut
2. Slot
3. Feeler gauge

Servicing the Fuel Tank

! **Danger** !

In certain conditions, gasoline is extremely flammable and highly explosive. A fire or explosion from gasoline can burn you and others and can damage property.

- **Drain gasoline from the fuel tank when the engine is cold. Do this outdoors in an open area. Wipe up any gasoline that spills.**
- **Never smoke when draining gasoline, and stay away from an open flame or where a spark may ignite the gasoline fumes.**

Draining the Fuel Tank

1. Park the machine on a level surface, to assure fuel tank drains completely. Then disengage the power take off (PTO), set the parking brake, and turn the ignition key to **off**. Remove the key.
2. Close fuel shut-off valve at fuel tank (Fig. 37).
3. Squeeze the ends of the hose clamp together and slide it up the fuel line away from valve (Fig. 37).
4. Pull the fuel line off the valve (Fig. 37). Open fuel shut-off valve and allow gasoline to drain into a gas can or drain pan.

Note: Now is the best time to install a new fuel filter because the fuel tank is empty. Refer to Replacing the Fuel Filter; page 33.

5. Install the fuel line onto the valve. Slide the hose clamp close to the valve to secure the fuel line.

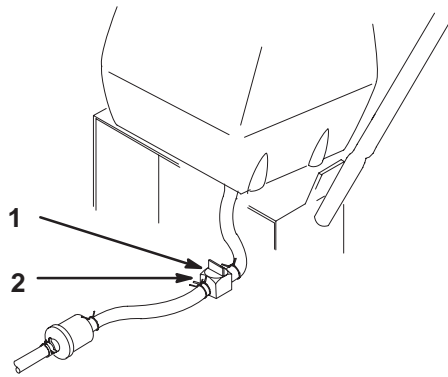

Figure 37

1. Fuel shut-off valve
2. Clamp

m-5235

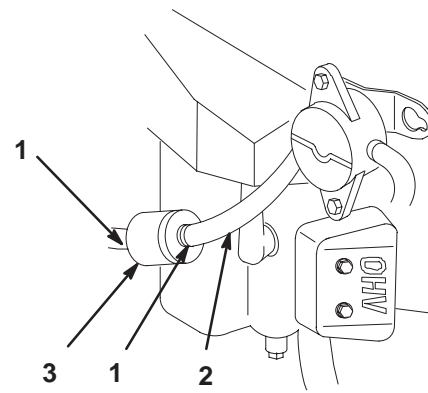

Figure 38

1. Hose clamp
2. Fuel line
3. Filter

M-4294

Servicing the Fuel Filter

Service Interval/Specification

Replace the fuel filter after every 200 operating hours or yearly, whichever occurs first.

Replacing the Fuel Filter

Never install a dirty filter if it is removed from the fuel line.

Note: Note how the fuel filter is installed.

1. Disengage the PTO and set the parking brake.
2. Stop the engine, remove the key, and wait for all moving parts to stop before leaving the operating position.
3. Close fuel shut-off valve at fuel tank (Fig. 37).

Note: Remove fuel line from fuel valve that is closest to the engine.

4. Squeeze the ends of the hose clamps together and slide them away from the filter (Fig. 38).
5. Remove the filter from the fuel lines.
6. Install a new filter and move the hose clamps close to the filter.
7. Open fuel shut-off valve at fuel tank (Fig. 37).
8. Check for fuel leaks and repair if needed.

Servicing the Hydraulic System

Checking the Hydraulic Fluid

Check the hydraulic fluid level before engine is first started.

Check the hydraulic fluid level after first 8 operating hours.

Check the hydraulic fluid level after every 40 operating hours.

Fluid Type: Mobil 1 15W-50 synthetic motor oil or equivalent synthetic oil.

Important Use oil specified or equivalent. Other fluids could cause system damage.

Hydraulic System Oil Capacity: 67 oz. (2.0 l)

Note: There are two ways of checking the hydraulic oil. One is when the oil is warm and one is when the oil is cold. The baffle inside the tank has two levels depending if the oil is warm or cold.

1. Position machine on a level surface and set the parking brake.
2. Clean area around filler neck of hydraulic tank (Fig. 39).
3. Remove cap from filler neck. Look inside to check if there is fluid in the reservoir. (Fig. 39).
4. If there is no fluid, add fluid to the reservoir until it reaches the **cold** level of the baffle.
5. Run the machine at low idle for 15 minutes to allow any air to purge out of the system and warm fluid. Refer to Starting and Stopping the Engine on page 18.

- Recheck the fluid level while the fluid is warm. If required, add fluid to the reservoir until it reaches the **hot** level of the baffle.

Note: The fluid level should be to the top of the **hot** level of the baffle, when the fluid is warm (Fig. 39).

- Install cap on filler neck.

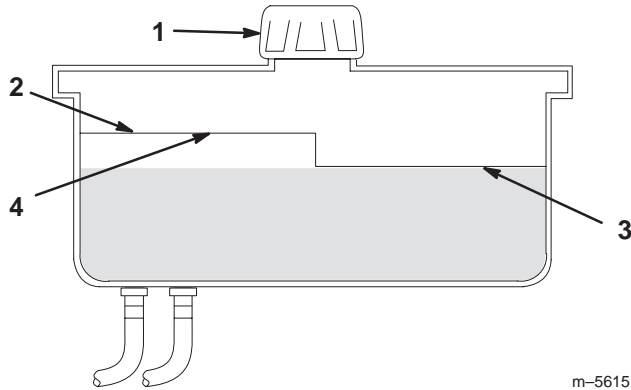

Figure 39

- | | |
|-----------|--------------------------|
| 1. Cap | 3. Cold fluid level—full |
| 2. Baffle | 4. Hot fluid level—full |

m-5615

Important Do not substitute automotive oil filter or severe hydraulic system damage may result.

- Remove hydro cap and temporarily cover opening with a plastic bag and rubber band to prevent all hydro fluid from draining out.
- Place drain pan under filter, remove the old filter and wipe the filter adapter gasket surface clean (Fig. 40).

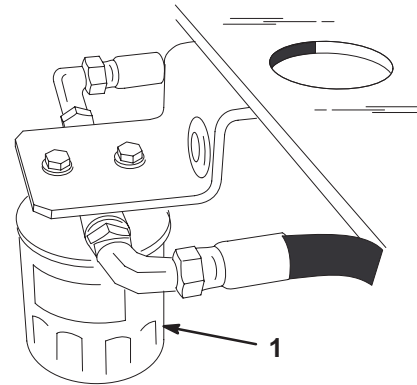

Figure 40

- Hydraulic filter

m-6575

Warning

Hydraulic fluid escaping under pressure can penetrate skin and cause injury.

- If hydraulic fluid is injected into the skin it must be surgically removed within a few hours by a doctor familiar with this type of injury. Gangrene may result if this is not done.
- Keep body and hands away from pin hole leaks or nozzles that eject high pressure hydraulic fluid.
- Use cardboard or paper to find hydraulic leaks.
- Safely relieve all pressure in the hydraulic system before performing any work on the hydraulic system.
- Make sure all hydraulic fluid hoses and lines are in good condition and all hydraulic connections and fittings are tight before applying pressure to hydraulic system.

Replacing the Hydraulic Filter

Change the hydraulic filter:

- After the first 200 operating hours.
 - Yearly, before storage.
- Position machine on a level surface, stop the engine, and remove key from ignition switch.

- Apply a thin coat hydro fluid to the rubber gasket on the replacement filter (Fig. 41).
- Install replacement hydraulic filter onto the filter adapter. Do not tighten.
- Remove plastic bag from tank opening and allow filter to fill with hydro fluid.
- When fluid overflows filter turn the oil filter clockwise until the rubber gasket contacts the filter adapter, then tighten the filter an additional 1/2 turn (Fig. 41).

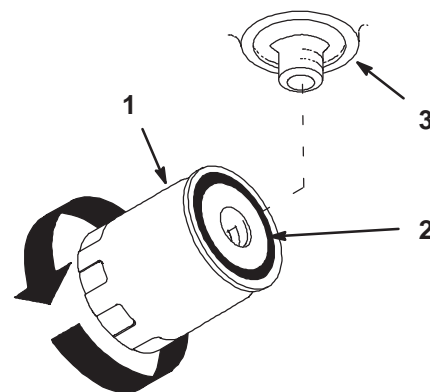

Figure 41

- | | |
|---------------------|------------|
| 1. Hydraulic filter | 3. Adapter |
| 2. Gasket | |

m-1256

- If there is no fluid, add fluid to reservoir approximately a 1/4 inch (6 mm) below the top of baffle.

9. Start engine and let run for about two minutes to purge air from the system. Stop the engine and check for leaks. If one or both wheels will not drive, refer Bleeding Hydraulic System, page 35.
10. Recheck level while fluid is warm. Add fluid to raise level to top of the baffle, if required. **Do not overfill.**

Bleeding the Hydraulic System

The traction system is self bleeding, however, it may be necessary to bleed the system if fluid is changed or after work is performed on the system.

1. Raise rear of the machine so wheels are off the ground and support with jack stands.
2. Start the engine and run at idle speed. Engage traction on one side and spin the wheel by hand.
3. When the wheel begins to spin on its own, keep it engaged until wheel drives smoothly (minimum 2 minute).
4. Check hydraulic fluid level as it drops and add as required to maintain proper level.
5. Repeat procedure on opposite wheel.

Checking the Hydraulic Lines

After every 100 operating hours, check hydraulic lines and hoses for leaks, loose fittings, kinked lines, loose mounting supports, wear, weather and chemical deterioration. Make necessary repairs before operating.

Note: Keep areas around hydraulic system clean from grass and debris build up.



Warning



Hydraulic fluid escaping under pressure can penetrate skin and cause injury.

- **If hydraulic fluid is injected into the skin it must be surgically removed within a few hours by a doctor familiar with this type of injury. Gangrene may result if this is not done.**
- **Keep body and hands away from pin hole leaks or nozzles that eject high pressure hydraulic fluid.**
- **Use cardboard or paper to find hydraulic leaks.**
- **Safely relieve all pressure in the hydraulic system before performing any work on the hydraulic system.**
- **Make sure all hydraulic fluid hoses and lines are in good condition and all hydraulic connections and fittings are tight before applying pressure to hydraulic system.**

Hydraulic Linkage Adjustments

Perform the following linkage adjustments when the machine needs maintenance or set-up for the first time.

Perform the steps Adjusting the Speed Control Linkage through Adjusting the Tracking. If adjustment is needed, do them in the order that they are listed.

Adjusting the Speed Control Linkage

1. Stop engine and wait for all moving parts to stop.
2. Move the speed control lever to the full forward position (Fig. 42).

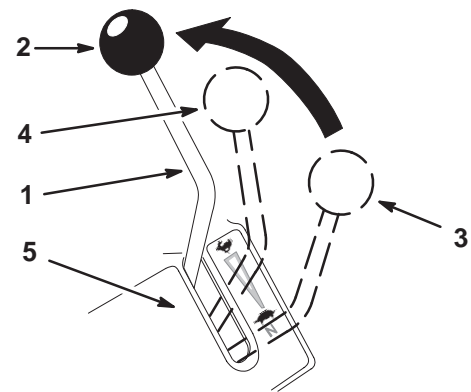

m-6477

Figure 42

- | | |
|------------------------|--------------------------|
| 1. Speed control lever | 4. Medium speed position |
| 2. Full speed position | 5. Control panel |
| 3. Neutral position | |

3. Check the orientation of the tabs on the ends of the speed control crank. These tabs should approximately be pointing straight down at the 6 o'clock position (Fig. 43).
4. If adjustment is needed, loosen the nuts on both sides of the swivel on the speed control rod (Fig. 43).
5. Adjust the swivel, until the tabs are at the 6 o'clock position (Fig. 43).
6. Tighten the nuts on both sides of the swivel (Fig. 43).

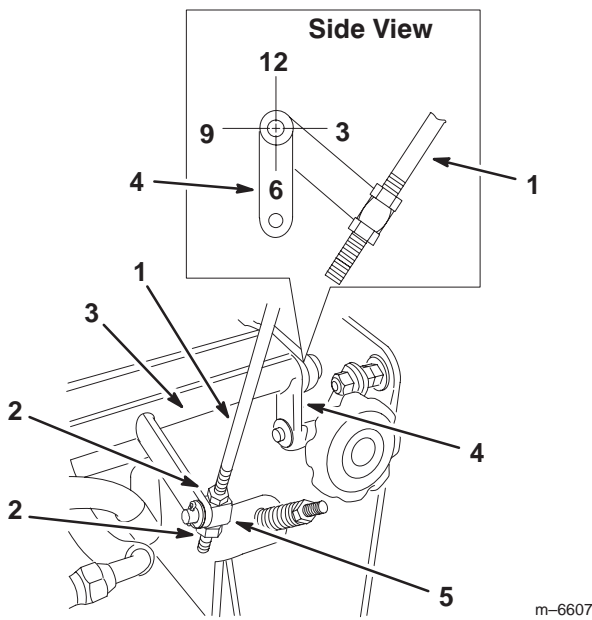

Figure 43

- | | |
|------------------------|-------------------------------|
| 1. Speed control rod | 4. Tabs in 6 o'clock position |
| 2. Nut | 5. Swivel |
| 3. Speed control crank | |

7. Pull the speed control lever back to neutral.
8. Check to make sure the safety switch is depressed and there is an 1/8 to 1/4 inch (3 to 6 mm) space between the actuating tab and the safety switch (Fig. 44).

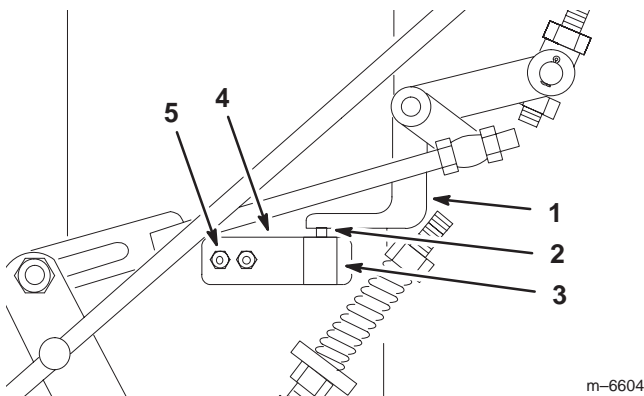

Figure 44

- | | |
|--------------------------|---------------------------|
| 1. Actuating tab | 4. Neutral bracket |
| 2. 1/8 to 1/4 inch space | 5. Neutral bracket screws |
| 3. Neutral safety switch | |

9. To adjust the switch location, loosen the two neutral bracket screws holding the switch plate to the frame (Fig. 44).
10. Adjust the switch up or down to obtain an 1/8 to 1/4 inch (3 to 6 mm) space (Fig. 44).
11. Tighten the two neutral bracket screws holding the switch plate (Fig. 44).

Temporary Neutral Stud Adjustment

1. Move the left and righthand neutral lock latches to the unlatched position (Fig. 11).
2. Move the speed control lever to the neutral position (Fig. 42).
3. Loosen the nut against the yoke (Fig. 45).
4. Adjust the length of the neutral stud and yoke assembly so the clevis pin does not contact the back of the slot in the control arm bracket (Fig. 45).
5. Tighten the nut against the yoke (Fig. 45).

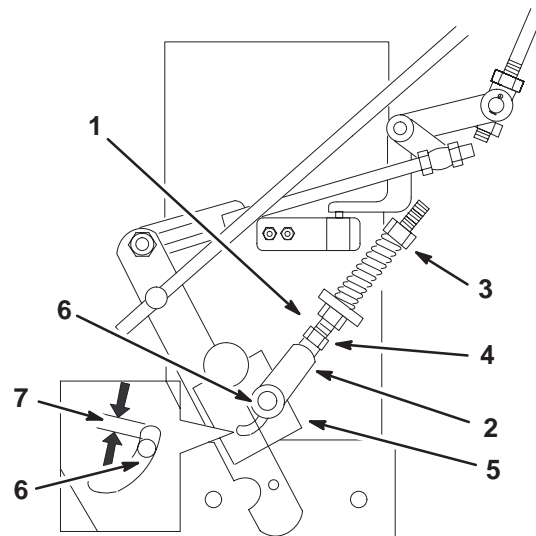

Figure 45

- | | |
|----------------------------|---|
| 1. Neutral control linkage | 5. Slot in control arm bracket |
| 2. Yoke | 6. Clevis pin |
| 3. Neutral stud | 7. Clevis pin does not contact the back of slot |
| 4. Nut | |

Adjusting the Hydraulic Control Linkages

Warning

Engine must be running so control linkage adjustments can be performed. Contact with moving parts or hot surfaces may cause personal injury.

Keep hands, feet, face, clothing and other body parts away from rotating parts, muffler and other hot surfaces.

Warning

Mechanical or hydraulic jacks may fail to support machine and cause a serious injury.

- Use jack stands when supporting the machine.
- Do not use hydraulic jacks.

Adjusting the Left Side Hydro Control Linkage

Warning

Electrical system will not perform proper safety shut off with Operator Presence Control (OPC) levers held in place.

- Make sure Operator Presence Control (OPC) levers are working when adjustment is completed.
- Never operate this unit with Operator Presence Control (OPC) levers held in place.

1. Raise the rear of the machine onto jack stands to raise the drive wheels off the ground.
2. Start the engine and move the throttle ahead to the full throttle position.
3. Press and hold the OPC levers down.

Note: The OPC levers must be held down whenever the speed control lever is out of the neutral position or the engine will kill.

4. Place the left neutral lock in the full forward position (Fig. 52) and move the speed control lever to the neutral position (Fig. 42).
5. Loosen the **front** nut on left hydro control linkage as shown in figure 47.
6. Turn the left **rear** adjusting nut counter-clockwise until wheel rotates forward (Fig. 47).
7. Turn the **rear** adjusting nut clockwise 1/4 of a turn at a time. Then move the speed control lever forward and back to neutral. Repeat this until left wheel stops rotating forward (Fig. 47).

Note: Make sure flat part of linkage is 90 degrees or perpendicular to pin part of swivel (Fig. 46).

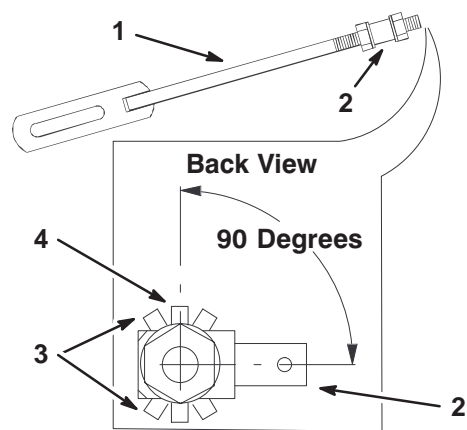

m-6606

Figure 46

- | | |
|--------------------------|-----------------------|
| 1. Hydro control linkage | 3. Incorrect position |
| 2. Swivel | 4. Correct position |

8. After adjusting the left hydro control linkage, move the speed control lever forward and then back to the neutral position.
9. Make sure the speed control lever is in the neutral position and the tire does not rotate.
10. Repeat adjustment if needed.

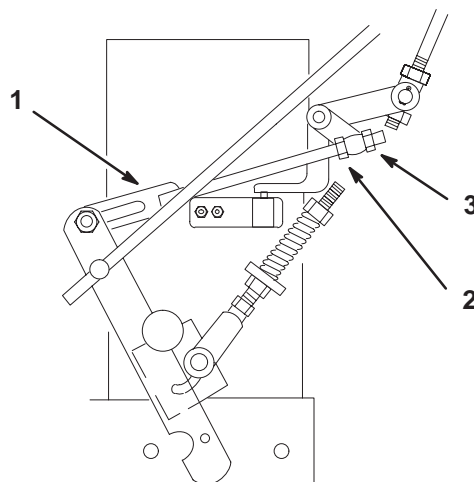

m-6604

Figure 47

- | | |
|--------------------------|-----------------------|
| 1. Hydro control linkage | 3. Rear adjusting nut |
| 2. Front nut | |

Note: If inconsistent neutral occurs, check to be sure both springs are properly tightened on the speed control lever under the console, especially the rear pivot spring. Repeat above adjustments if necessary (Fig. 48).

11. Tighten the **front** nut on left hydro control linkage shown in figure 47.

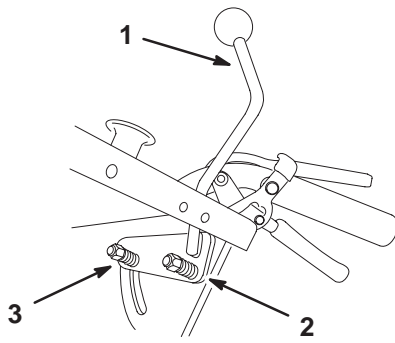

Figure 48

1. Speed control lever
2. Rear pivot spring
3. spring

m-5396

Right Side Linkage Adjustment

1. With the machine on jack stands, place the speed control lever in the neutral position (Fig. 42).
2. Place the right drive lever in the full forward position (Fig. 52).
3. Hold the OPC levers down.

Note: The OPC levers must be held down whenever the speed control lever is out of the neutral position or the engine will kill.

4. Adjust the right side linkage by turning the quick track knob counterclockwise until the tire begins to rotate forward (Fig. 49).
5. Turn the knob clockwise 1/4 of a turn at a time. Then move the speed control forward and back to neutral. Repeat this until right wheel stops rotating forward (Fig. 49).
6. The spring that keeps tension on the knob should normally not need adjustment. However, if adjustment is needed, adjust the length of the spring to 1 inch (26 mm) between the washers (Fig. 49).
7. Adjust spring length by turning the nut at the **front** of the spring (Fig. 49).
8. After adjusting the right hydro control linkage, move the speed control lever forward and then back to the neutral position.
9. Make sure the speed control lever is in the neutral position and the tire **does not** rotate.

10. Repeat adjustment if needed.

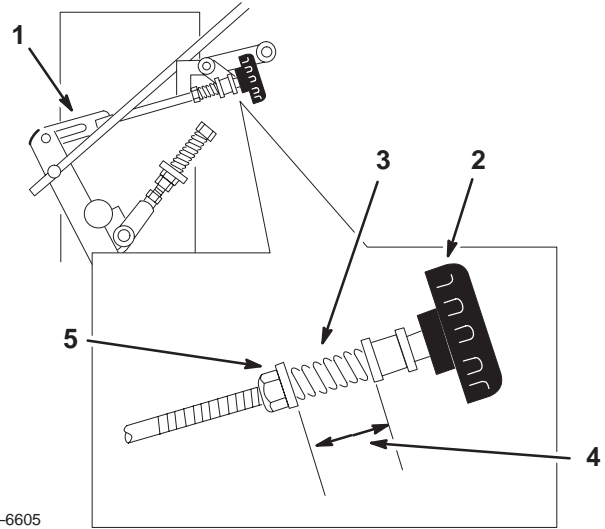

Figure 49

1. Hydro control linkage
2. Quick track knob
3. Spring
4. 1 inch (26 mm)
5. Nut in front of spring

Adjusting the Neutral Stud



Warning



Electrical system will not perform proper safety shut off with Operator Presence Control (OPC) levers held in place.

- **Make sure Operator Presence Control (OPC) levers are working when adjustment is completed.**
- **Never operate this unit with Operator Presence Control (OPC) levers held in place.**

1. With the machine on jack stands, place the speed control lever in the neutral position (Fig. 42).
2. Hold the OPC levers down.

Note: The OPC levers must be held down whenever the speed control lever is out of the neutral position or the engine will kill.

3. Adjust the left and right neutral stud until the clevis pin in the yoke touches the back end of the slot in the control arm (Fig. 50).

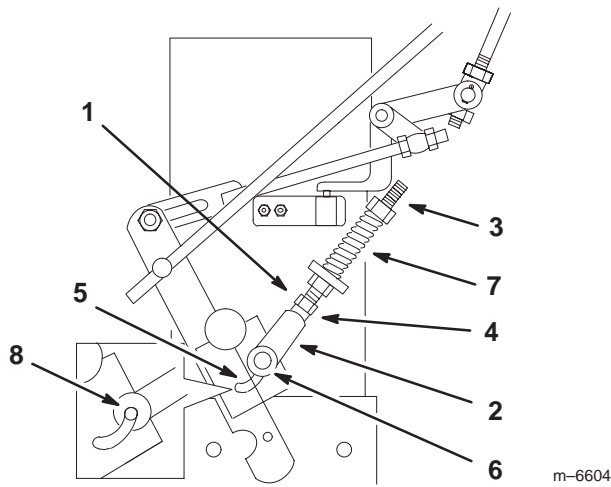

Figure 50

- | | |
|----------------------------|--------------------------------|
| 1. Neutral control linkage | 5. Slot in control arm bracket |
| 2. Yoke | 6. Clevis pin |
| 3. Neutral stud | 7. Spring |
| 4. Nut | 8. Back end of slot |

4. Move the speed control lever to the full forward position (Fig. 42).

5. Squeeze one drive lever until an **increased** resistance is felt (Fig. 52). **This is neutral position.** This is where the clevis pin in the yoke comes to the back end of the slot in the control arm bracket.

Note: Make sure you have not reached the end of the neutral lock slot (Fig. 52). If you have, shorten the control rod. Refer to Adjusting the Control Rod on page 39.

6. If the wheel turns while holding the drive lever in neutral position, the neutral stud needs to be adjusted (Fig. 45). If the wheel does not rotate, then go to step 12.

7. Loosen the nut against the yoke (Fig. 50).

8. Adjust the adjustment stud until the respective drive wheel stops while holding the drive in neutral position (increase resistance) (Fig. 45).

9. Turn the adjusting bolt approximately 1/4 turn clockwise if the wheel is turning in reverse and turn the bolt approximately 1/4 turn counter-clockwise if the wheel is turning forward (Fig. 45).

10. Release the drive lever to the forward drive position and squeeze back into the neutral position (Fig. 52). Check to see if the wheel stops. If not, repeat steps 8 and 9.

11. After adjustments are made, tighten the nut against the yoke.

12. Repeat this procedure for the opposite side.

Adjusting the Control Rod

Checking the Control Rod

1. With rear of machine still on jack stands and engine running at full throttle, move the speed control lever to the medium speed position.

Note: The OPC levers must be held down whenever the speed control lever is out of the neutral position or the engine will kill.

2. Move the respective drive lever upward until it reaches the neutral position and engage neutral locks.

3. If the tire rotates in either direction, the length of the control rod will need to be adjusted.

Adjusting the Control Rods

1. Adjust the rod length by releasing the drive lever and removing the hairpin cotter pin and clevis pin (Fig. 51). Rotate the rod in the rod fitting (Fig. 52).

2. Lengthen the rod if the tire is turning in reverse and shorten the rod if the tire is turning forward.

3. Rotate the rod several turns if the tire is rotating fast. Then, adjust the rod in 1/2 turn increments.

4. Place the clevis pin in to the drive lever (Fig. 51).

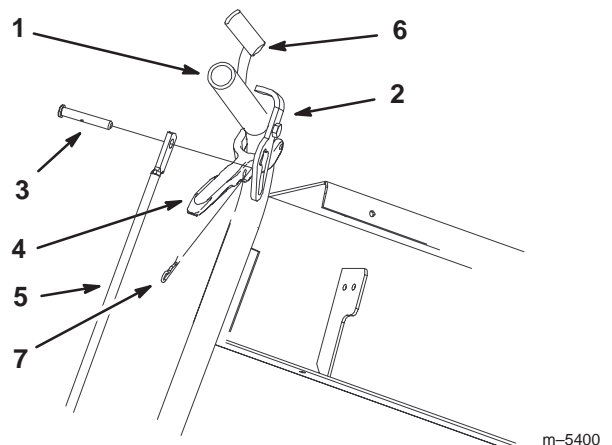

Figure 51

- | | |
|----------------------|--|
| 1. Left handle shown | 5. Control rod |
| 2. Neutral lock | 6. Operator Presence Control lever (OPC) |
| 3. Clevis pin | 7. Hairpin cotter |
| 4. Drive lever | |

5. Release and engage neutral lock checking that the tire does not rotate. Continue this process until the tire does not rotate.

6. Install hairpin cotter between drive levers and neutral locks and into clevis pins (Fig. 51).

Note: Make sure the clevis pins are inserted into the neutral locks.

7. Repeat this adjustment for opposite side.

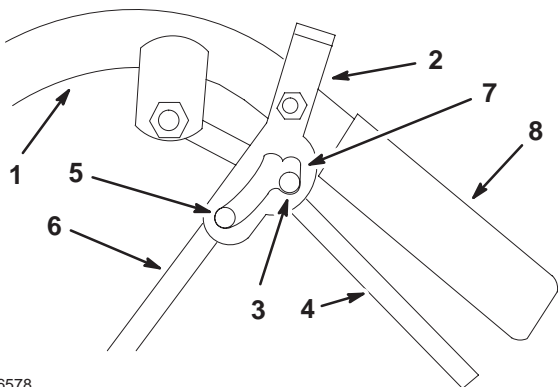

Figure 52

- | | |
|---------------------|-----------------------|
| 1. Handle | 5. Full speed forward |
| 2. Neutral lock | 6. Control rod |
| 3. Neutral position | 7. Neutral lock slot |
| 4. Drive lever | 8. Grip |

Adjusting the Tracking

1. Remove the machine from any jack stands.
2. Check the rear tire pressure. Refer to Checking the Tire Pressure Service on page 32.
3. Start and run the unit. Observe the tracking on a level, smooth, hard surface such as concrete or asphalt.
4. If the unit tracks to one side or the other, turn the quick track knob. Turn the knob right to steer right and turn the knob left to steer left (Fig. 53).

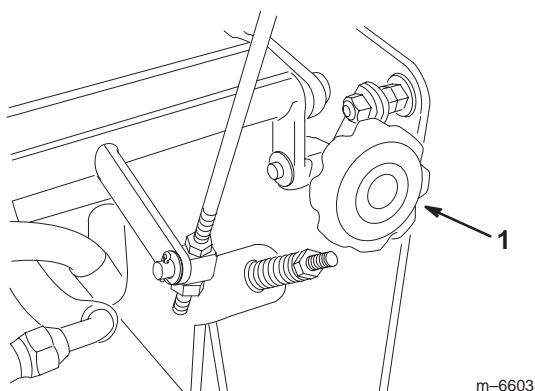

Figure 53

1. Quick track knob

Servicing the Brake

Service Interval/Specification

Before each use, check brake for proper operation.

Always set the parking brake when you stop the machine or leave it unattended. If the parking brake does not hold securely, an adjustment is required.

Checking the Brake

1. Park the machine on a level surface.
2. Disengage the PTO and set the parking brake.
3. Stop the engine, remove the key, and wait for all moving parts to stop before leaving the operating position.
4. To set the parking brake, it should take a reasonable amount of force. If it engages too hard or easily, adjustment is required. Refer to Adjusting the Brake on page 40.

Note: When the brake is engaged, the brake handle should be close to the 1 o'clock position.

5. If there is a reasonable amount of force, no adjustment is required.

Adjusting the Brake

The brake handle is on the left side of machine (Fig. 54). If the parking brake does not hold securely, an adjustment is required.

1. Check the brake before you adjust it; refer to Checking the Brake, page 40.
2. Release the parking brake; refer to Releasing the Parking Brake, page 19.
3. Loosen the top and bottom jam nuts (Fig. 54).
4. To adjust the brake, remove the hair pin cotter and clevis pin from the lower brake lever (Fig. 54).
5. Rotate the brake rod in the yokes. To tighten the brake, lengthen the rod between the yokes. To loosen the brake, shorten the rod between the yokes (Fig. 54).

Note: The brake rod should be threaded into both yokes the same distance.

6. Secure the yoke to lower brake lever with the hair pin cotter and clevis pin (Fig. 54).
7. Tighten the top and bottom jam nuts (Fig. 54).
8. Check the brake operation again; refer to Checking the Brake, page 40.

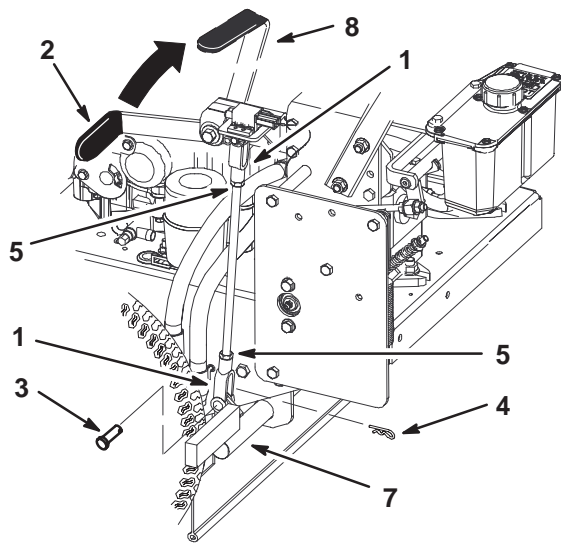

Figure 54

- | | |
|---|-----------------------|
| 1. Yoke | 5. Jam nut |
| 2. Parking brake lever
(released position) | 6. Brake rod |
| 3. Clevis pin | 7. Lower brake lever |
| 4. Hairpin cotter | 8. 1 o'clock position |

m-6614

Adjusting the Electric Clutch

The clutch is adjustable to ensure proper engagement and proper braking. Check adjustment after every 100 hours of operation.

1. To adjust clutch, tighten or loosen lock nuts on flange studs (Fig. 55).
2. Check adjustment by inserting feeler gauge through slots next to studs (Fig. 55).
3. The proper disengaged clearance between the clutch plates is 0.012–0.024 inch (0.30-0.60 mm). It will be necessary to check this clearance at each of the three slots to ensure the plates are parallel to each other.

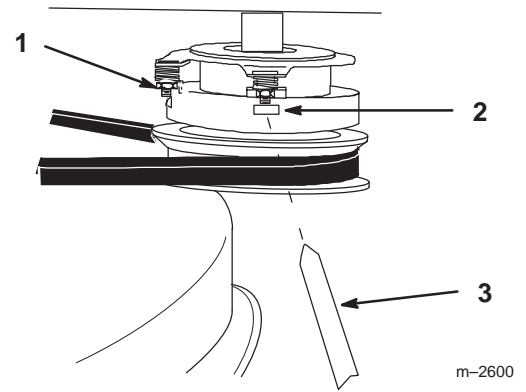

Figure 55

- | | |
|------------------|-----------------|
| 1. Adjusting nut | 3. Feeler gauge |
| 2. Slot | |

m-2600

Servicing the Cutting Blades

To ensure a superior quality of cut, keep the blades sharp. For convenient sharpening and replacement, you may want to keep extra blades on hand.



Warning



A worn or damaged blade can break, and a piece of the blade could be thrown into the operator's or bystander's area, resulting in serious personal injury or death.

- **Inspect the blade periodically for wear or damage.**
- **Replace a worn or damaged blade.**

Before Inspecting or Servicing the Blades

Park the machine on a level surface, disengage the blade control (PTO) and set the parking brake. Turn the ignition key to **off**. Remove the key and disconnect the spark plug wire(s) from the spark plug(s).

Inspecting the Blades

1. Inspect the cutting edges (Fig. 56). If the edges are not sharp or have nicks, remove and sharpen the blades. Refer to Sharpening the Blades on page 43.
2. Inspect the blades, especially the curved area (Fig. 56). If you notice any damage, wear, or a slot forming in this area (item 3 in Fig. 56), immediately install a new blade.

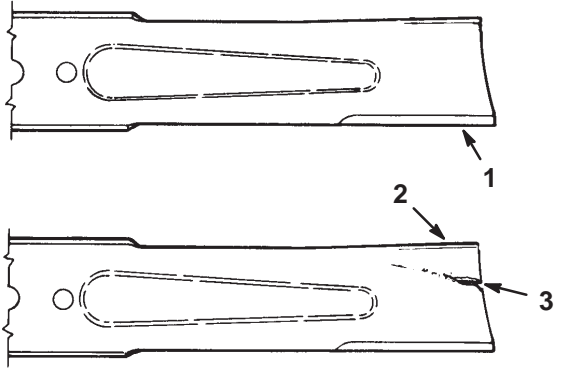

m-151

Figure 56

1. Cutting Edge
2. Curved Area
3. Wear/slot Forming

Checking for Bent Blades

1. Rotate the blades until the ends face forward and backward (Fig. 57). Measure from a level surface to the cutting edge, position A, of the blades (Fig. 58). Note this dimension.

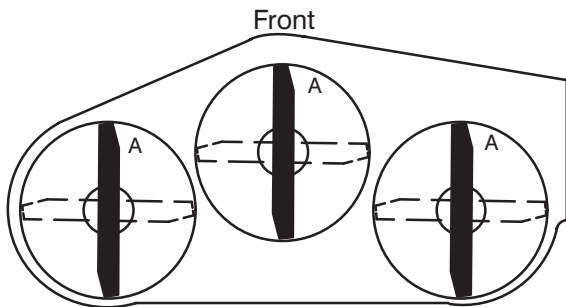

m-1078

Figure 57

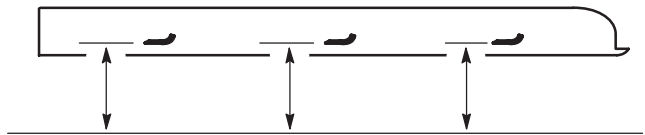

MEASURE FROM
CUTTING EDGE TO A
LEVEL SURFACE

m-2539

Figure 58

2. Rotate the opposite ends of the blades forward.
3. Measure from a level surface to the cutting edge of the blades at the same position as in step 1. The difference between the dimensions obtained in steps 1 and 2 must not exceed 1/8 inch (3 mm). If this dimension exceeds 1/8 inch (3 mm), the blade is bent and must be replaced. Refer to Removing the Blades and Installing the Blades.



Warning



A blade that is bent or damaged could break apart and could seriously injure or kill you or bystanders.

- Always replace bent or damaged blade with a new blade.
- Never file or create sharp notches in the edges or surfaces of blade.

Removing the Blades

Blades must be replaced if a solid object is hit, if the blade is out of balance or is bent. To ensure optimum performance and continued safety conformance of the machine, use genuine TORO replacement blades. Replacement blades made by other manufacturers may result in non-conformance with safety standards.

1. Hold the blade end using a rag or thickly-padded glove. Remove the blade bolt, washer, lock washer and blade from the spindle shaft (Fig. 59).

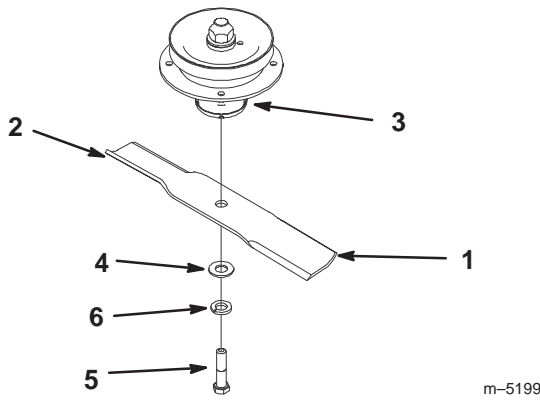

Figure 59

- | | |
|-----------------------|----------------|
| 1. Sail Area of Blade | 4. Washer |
| 2. Blade | 5. Blade bolt |
| 3. Blade spindle | 6. Lock washer |

Sharpening the Blades

1. Use a file to sharpen the cutting edge at both ends of the blade (Fig. 60). Maintain the original angle. The blade retains its balance if the same amount of material is removed from both cutting edges.



Figure 60

1. Sharpen at original angle

2. Check the balance of the blade by putting it on a blade balancer (Fig. 61). If the blade stays in a horizontal position, the blade is balanced and can be used. If the blade is not balanced, file some metal off the end of the sail area only (Fig. 59). Repeat this procedure until the blade is balanced.

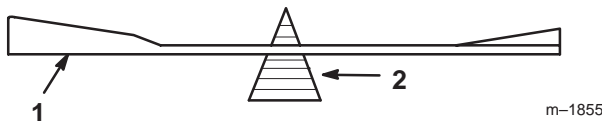

Figure 61

- | | |
|----------|-------------|
| 1. Blade | 2. Balancer |
|----------|-------------|

Installing the Blades

1. Install the blade onto the spindle shaft (Fig. 59).

Important The sail part of the blade must be pointing upward, toward the inside of the mower to ensure proper cutting (Fig. 59).

2. Install the lock washer and blade bolt (Fig. 59).
Torque the blade bolt to 85–110 ft-lb (115–140 N•m).

Correcting the Mower Quality of Cut

If one deck blade cuts lower than the other, correct as follows.

Note: Tire air pressure is critical in these procedures. Make sure all tires have correct pressure.

1. Disengage the PTO and set the parking brake.
2. Stop the engine, remove the key, and wait for all moving parts to stop before leaving the operating position.
3. Adjust the tire pressure in all tires to specifications on page 32.
4. Check that the blades and spindle shafts are not bent. Refer to Checking for Bent Blades on page 42.
5. Set the height-of-cut to the 4 inch (101.6 mm) position. Refer to Adjusting the Height-Of-Cut in the Operation section.
6. Perform steps in the following sections Frame Set Up, Checking Front-to-Rear Pitch and Checking Side-to-Side Leveling.

Frame Set Up

Checking Carrier Frame and Deck Alignment

1. Disengage the PTO and set the parking brake.
2. Stop the engine, remove the key, and wait for all moving parts to stop before leaving the operating position.
3. Place a long straight edge on top of the engine deck as shown in figure 62.
4. At the carrier frame cross tube, measure location A height (Fig. 62). This measurement must be 1–5/16 inch (33 mm), plus or minus a 1/4 inch (6 mm).
5. If the height at location A is not correct, adjustment is needed.
6. Loosen the carrier frame mounting bolts on both sides of the machine (Fig. 62).
7. Align the carrier frame and engine deck to match 1–5/16 inch (33 mm), plus or minus a 1/4 inch (6 mm) at location A (Fig. 62).

- Tighten the carrier frame mounting bolts on both sides of the machine.

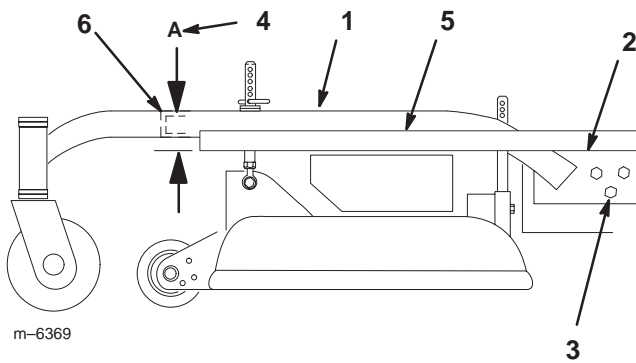

Figure 62

- | | |
|---------------------------------|---|
| 1. Carrier Frame | 4. Location A , 1–5/16 inch (33 mm) ±1/4 inch (6 mm) |
| 2. Top of engine deck | 5. Straight edge |
| 3. Carrier frame mounting bolts | 6. Carrier frame cross tube |

Checking Engine Deck Height

- Disengage the PTO and set the parking brake.
- Stop the engine, remove the key, and wait for all moving parts to stop before leaving the operating position.
- Adjust the tire pressure in all tires to specifications on page 32.
- Measure engine deck height at location **A** (Fig. 63).
- Measure engine deck height at location **B** (Fig. 63).
- If the height at location **A** and **B** are not the same, change tire pressure slightly to make them the same.

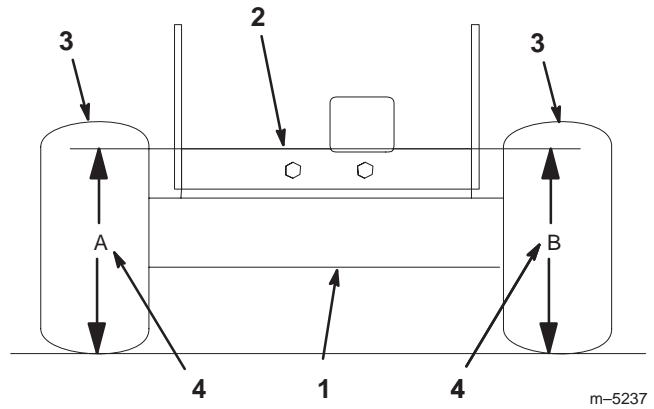

Figure 63

- | | |
|-------------------------|---|
| 1. Back view of machine | 4. Same height at locations A and B |
| 2. Top of engine deck | |
| 3. Tires | |

Checking Carrier Frame Front-to-Rear Pitch

The carrier frame must have a pitch of a 1/4 inch (6 mm) over the length of 24 inches (61 cm) on the carrier frame (Fig. 64).

- Measure out 24 inches (61cm) on the carrier frame (Fig. 64).
- Measure carrier frame height at location **A** (Fig. 64).
- Measure carrier frame height at location **B** (Fig. 64).
- The height at location **A** must be a 1/4–3/8 inch (6 mm –10 mm) lower than location **B** (Fig. 64).
- If the carrier frame is not correct, move caster spacers to make it a 1/4–3/8 inch (6 –10 mm) pitch (Fig. 64). Move spacers from top or bottom to make the correct pitch.
- The tire pressure may also be adjusted slightly to make a 1/4 inch (6 mm) pitch.

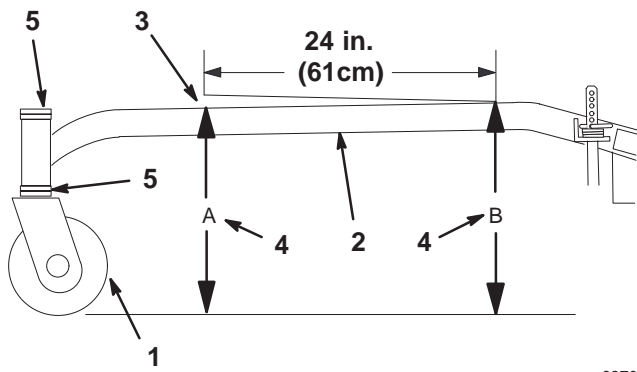

m-6370

Figure 64

- | | |
|--|--------------------------------|
| 1. Caster Wheel | 4. Height at locations A and B |
| 2. Carrier Frame | 5. Caster spacers |
| 3. 1/4–3/8 inch (6 mm–10 mm) pitch over 24 inch (61 cm) length | |

Checking Carrier Frame Side-to-Side

1. Disengage the PTO and set the parking brake.
2. Stop the engine, remove the key, and wait for all moving parts to stop before leaving the operating position.
3. Adjust the tire pressure in all tires to specifications on page 32.
4. Measure carrier frame height at location **A** (Fig. 65).
5. Measure carrier frame height at location **B** (Fig. 65).
6. If the carrier frame height is not the same move spacers from top or bottom of caster wheel, to make it level. The tire pressure may also be adjusted slightly to make it level.

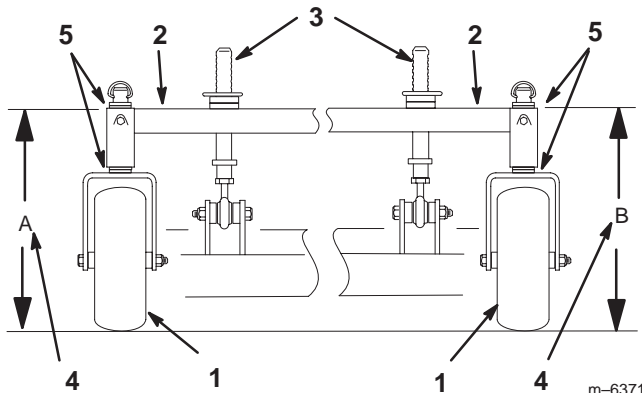

m-6371

Figure 65

- | | |
|-----------------------------|-------------------------------------|
| 1. Caster Wheel | 4. Same height at locations A and B |
| 2. Carrier Frame | 5. Caster spacers |
| 3. Front height-of-cut pins | |

Checking the Deck Front-to-Rear Pitch

1. Check the tire pressure on both deck and traction unit.
2. Position one blade front-to-rear (Fig. 66). Measure at **C** and **D** locations (Fig. 66) from a level surface to the cutting edge of the blade tips (Fig. 67).
3. The mower blade should be **1/4 inch (6 mm) lower in front at C than in the rear at D**. Rotate blades and repeat for other blades. If it is not correct, proceed to Changing the Deck Front-to-Rear Pitch.

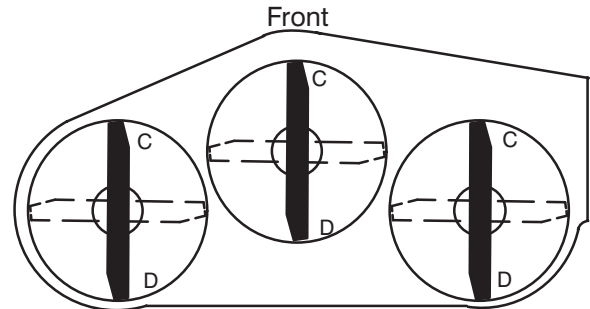

m-1078

Figure 66

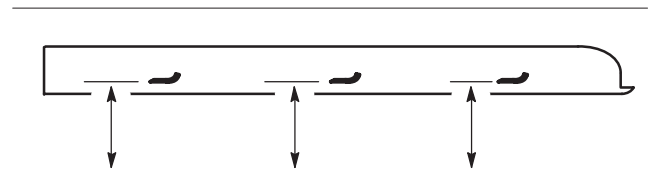

MEASURE FROM CUTTING EDGE TO A LEVEL SURFACE

m-2539

Figure 67

Changing the Deck Front-to-Rear Pitch

Changing the front-to-rear pitch is done by adjusting the front height-of-cut posts.

Changing the Deck Front-to-Rear Pitch by Adjusting Front Height-of-Cut Posts

1. To change the front-to-rear pitch, the front height-of-cut posts can be adjusted (Fig. 68).
2. To raise the front of the deck, loosen jam nut and rotate the front pin clockwise (Fig. 68).
3. To lower the front of the deck, loosen jam nut and rotate the front pin counter clockwise (Fig. 68).

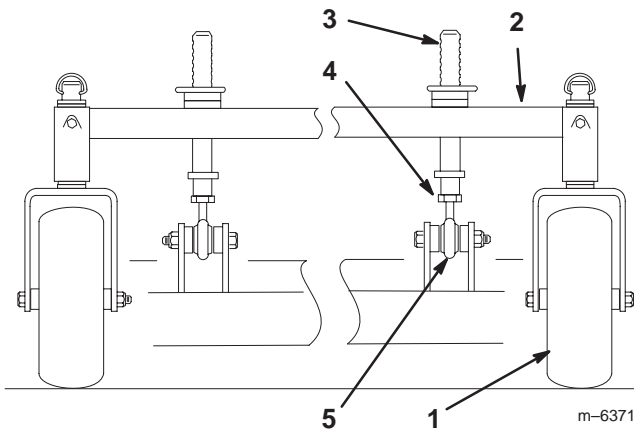

Figure 68

- | | |
|-----------------------------|---------------|
| 1. Caster Wheel | 4. Jam nut |
| 2. Carrier Frame | 5. Ball joint |
| 3. Front height-of-cut pins | |

4. Position the blades front-to-rear (Fig. 66). Measure at **C** and **D** locations (Fig. 66) from a level surface to the cutting edge of the blades (Fig. 67).
5. Check the side-to-side leveling of the cutting unit.

Checking the Deck Side-to-Side Leveling

1. Check the tire pressure on both deck and traction unit.
2. Position the blades side-to-side (Fig. 69). Measure at **A** and **B** locations (Fig. 69) from a level surface to the cutting edge of blade tips (Fig. 70).
3. The difference between measurements **A** and **B** should be no more than 1/4 inch (6 mm).

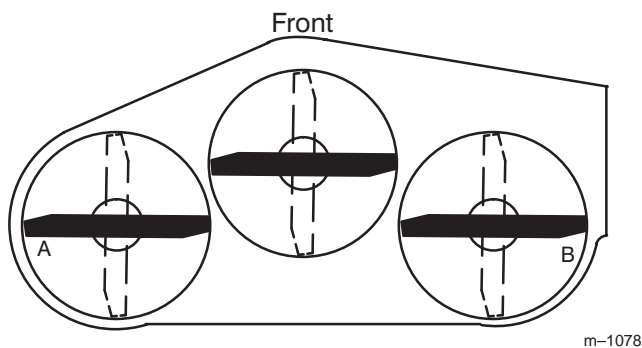
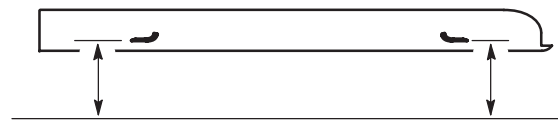

Figure 69



MEASURE FROM
CUTTING EDGE TO
A LEVEL SURFACE

Figure 70

Changing the Side-to-Side Leveling

Changing the side-to-side leveling is done by adjusting tire pressure.

Changing the Side-to-Side Leveling with Tire Pressure

1. Change the tire pressure on both deck and traction unit. Do this to the corresponding side that needs adjustment.
2. Recheck the front-to-rear pitch and side to side leveling of the cutting unit.

Matching the Height of Cut

1. Check the tire pressure on both deck and traction unit.
2. Set the height-of-cut to the 4 inch (101.6 mm) position following the height-of-cut decal.
3. With the machine on level surface, position one blade front-to-rear (Fig. 71). Measure at **A** and from level surface to the cutting edge of the blade tips (Fig. 71).
4. The measurement should be 4 inch (101.6 mm).

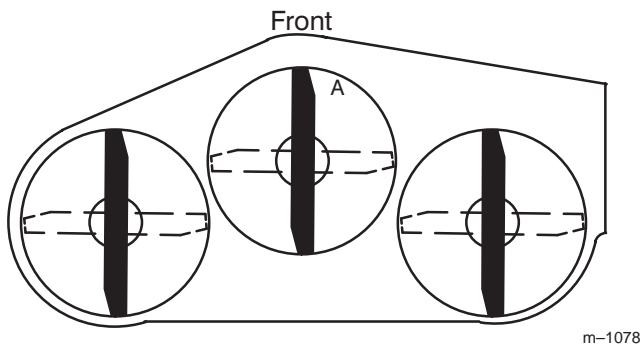
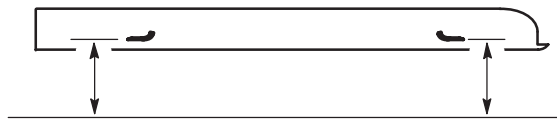

Figure 71



MEASURE FROM
CUTTING EDGE TO
A LEVEL SURFACE

Figure 72

5. If it does not measure correctly, add air pressure in rear tires to raise height-of-cut
6. If it does not measure correctly, decrease air pressure in rear tires to lower height-of-cut.
7. Check carrier frame front-to-rear pitch.

Replacing the Mower Belt

Squealing when the belt is rotating, blades slipping when cutting grass, frayed belt edges, burn marks and cracks are signs of a worn deck belt. Replace the deck belt if any of these conditions are evident.

1. Stop the engine, remove the key and disconnect the spark plug wire(s) from the spark plug(s).
2. Remove the knobs holding the carrier frame cover and remove the carrier frame cover.
3. Remove the knobs holding the belt covers to the cutting unit and remove the belt covers.
4. Remove the PTO drive belt. Refer to Replacing the PTO Drive Belt on page 47.
5. Disconnect the idler arm spring to relieve tension on the idler arm and idler pulley, then remove the worn deck belt (Fig. 73).
6. Install the new deck belt around the two outside spindle pulleys, the idler pulley, and in the lower groove of the center spindle pulley (Fig. 73).
7. Connect the idler arm spring (Fig. 73).

8. Reinstall the PTO drive belt. Refer to Replacing the PTO Drive Belt page 47.
9. Adjust deck belt guide an 1/8 inch (3 mm) from belt (Fig. 73).
10. Reinstall the deck covers onto the cutting unit, then reinstall and tighten the knobs.
11. Install the carrier frame cover onto the cutting unit, then install and tighten the hand knobs.

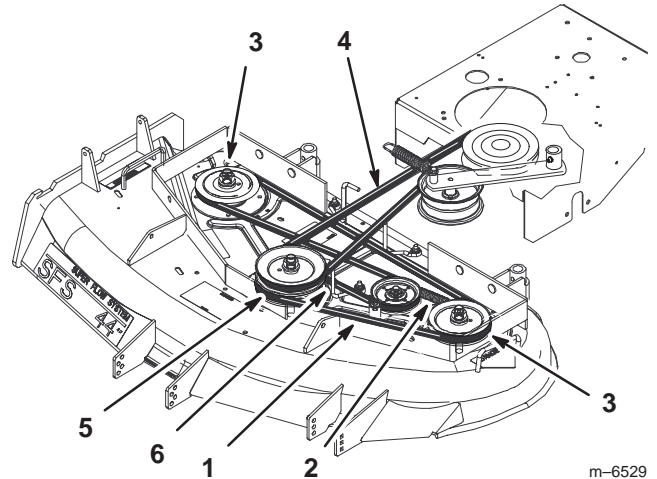

Figure 73

- | | |
|---------------------|--------------------------|
| 1. Deck belt | 4. PTO drive Belt |
| 2. Idler arm spring | 5. Center Spindle Pulley |
| 3. Outside pulley | 6. Deck belt guide |

Replacing the PTO Drive Belt

Squealing when the belt is rotating, blades slipping when cutting grass, frayed belt edges, burn marks and cracks are signs of a worn drive belt. Replace the drive belt if any of these conditions are evident.

1. Stop the engine, remove the key and disconnect the spark plug wire(s) from the spark plug(s).
2. Remove the knobs holding the carrier frame cover and remove the carrier frame cover.
3. Remove the knobs holding the belt covers to the top of the cutting unit and remove the belt covers.
4. Remove the idler spring from idler arm. Remove the drive belt from the PTO engagement pulley and the center spindle pulley (Fig. 74).
5. Remove the worn drive belt (Fig. 74).
6. Install the new drive belt onto the PTO engagement pulley and the top groove of the center spindle pulley (Fig. 74).
7. Install belt onto idler pulley and then install idler spring (Fig. 74).

8. Adjust PTO drive belt guides an 1/8 inch (3 mm) from belt (Fig. 74).
9. Install the belt covers onto the cutting unit, then install and tighten the knobs.
10. Install the carrier frame cover onto the cutting unit, then install and tighten the hand knobs.

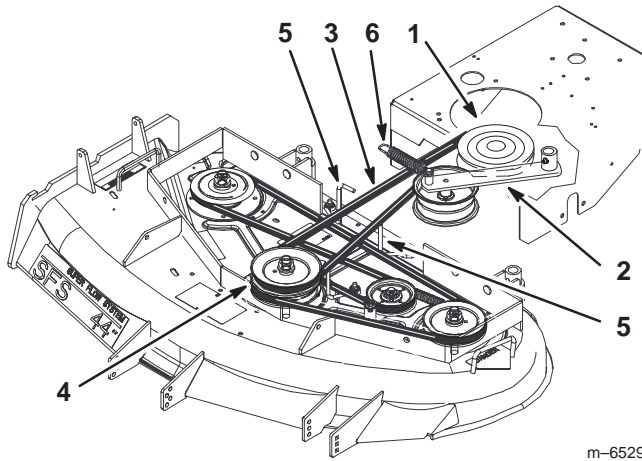

Figure 74

- | | |
|--------------------------|--------------------------|
| 1. PTO engagement pulley | 4. Center Spindle Pulley |
| 2. PTO drive belt idler | 5. PTO Drive belt guide |
| 3. PTO drive Belt | 6. Idler Spring |

Replacing the Caster Wheel Fork Bushings

The caster wheel forks are mounted in bushings pressed into the top and bottom of the carrier frame mounting tubes. To check the bushings, move the caster forks back and forth and side-to-side. If a caster fork is loose, the bushings are worn and must be replaced.

1. Raise the cutting unit so the caster wheels are off the floor, then block up the front of the mower with jack stands.
2. Remove the locking pin and spacer(s) from the top of the caster wheel fork (Fig. 75).
3. Pull the caster wheel fork out of the mounting tube, leaving the spacer(s) on the bottom of the fork. Remember the location of the spacers on each fork to ensure correct installation, and to maintain a level deck.

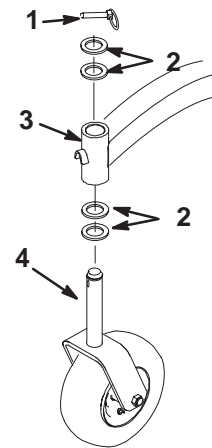

Figure 75

- | | |
|---------------------------------|--------------------------------|
| 1. Locking Pin | 3. Carrier frame mounting tube |
| 2. Spacers (locate as required) | 4. Caster wheel fork |

4. Insert a pin punch into the mounting tube and carefully drive out the bushings (Fig. 76). Clean the inside of the mounting tube.
5. Grease the inside and outside of the new bushings. Use a hammer and flat plate to carefully drive the bushings into the mounting tube.
6. Inspect the caster wheel fork for wear and replace if necessary (Fig. 75).
7. Slide the caster wheel fork through the bushings in the mounting tube. Replace the spacer(s) onto the fork and secure with the retaining ring (Fig. 75).

Important The inside diameter of the bushings may collapse slightly when installed. If the caster wheel fork does not slide into the new bushings, ream both bushings to an inside diameter of 1.126 inch (29 mm).

8. Grease the fitting on the carrier frame mounting tube using No. 2 general purpose lithium base or molybdenum base grease.

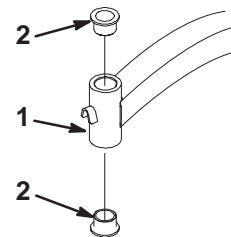

Figure 76

- | | |
|------------------|------------|
| 1. Mounting Tube | 2. Bushing |
|------------------|------------|

Caster Wheel and Bearings Service

The caster wheels rotate on a roller bearing supported by a spanner bushing. If the bearing is kept well lubricated, wear will be minimal. Failure to keep the bearing well lubricated will cause rapid wear. A wobbly caster wheel usually indicates a worn bearing.

1. Remove the locknut and wheel bolt holding the caster wheel to the caster fork (Fig. 77).
2. Remove one bushing, then pull the spanner bushing and roller bearing out of the wheel hub (Fig. 77).
3. Remove the other bushing from the wheel hub and clean any grease and dirt from the wheel hub (Fig. 77).
4. Inspect the roller bearing, bushings, spanner bushing and inside of the wheel hub for wear. Replace any defective or worn parts (Fig. 77).

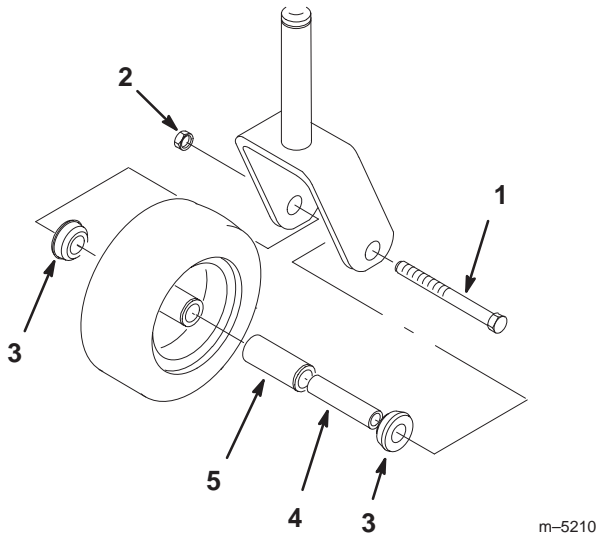

Figure 77

- | | |
|---------------|--------------------|
| 1. Locknut | 4. Spanner Bushing |
| 2. Wheel Bolt | 5. Roller Bearing |
| 3. Bushing | |

5. To assemble, place one bushing into the wheel hub. Grease the roller bearing and spanner bushing and slide them into the wheel hub. Place the second bushing into the wheel hub (Fig. 77).
6. Install the caster wheel into the caster fork and secure with the wheel bolt and locknut. Tighten the locknut until the spanner bushing bottoms against the inside of the caster forks (Fig. 77).
7. Grease the fitting on the caster wheel.

Replacing the Grass Deflector



Warning



An uncovered discharge opening could allow the lawn mower to throw objects in the operator's or bystander's direction and result in serious injury. Also, contact with the blade could occur.

Never operate the lawn mower unless you install a cover plate, a mulch plate, or a grass chute and catcher.

1. Remove the locknut, bolt, spring and spacer holding the deflector to the pivot brackets (Fig. 78). Remove damaged or worn grass deflector.
2. Place spacer and spring onto grass deflector. Place the L end of spring behind deck edge.

Note: Make sure the L end of spring is installed behind deck edge before installing the bolt as shown in figure 78.

3. Install bolt and nut. Place the J hook end of spring around grass deflector (Fig. 78).

Important The grass deflector must be able to lower down into position. Lift the deflector up to test that it lowers into the full down position.

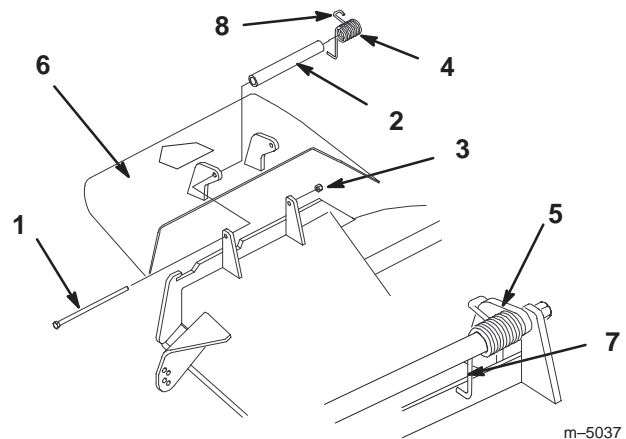
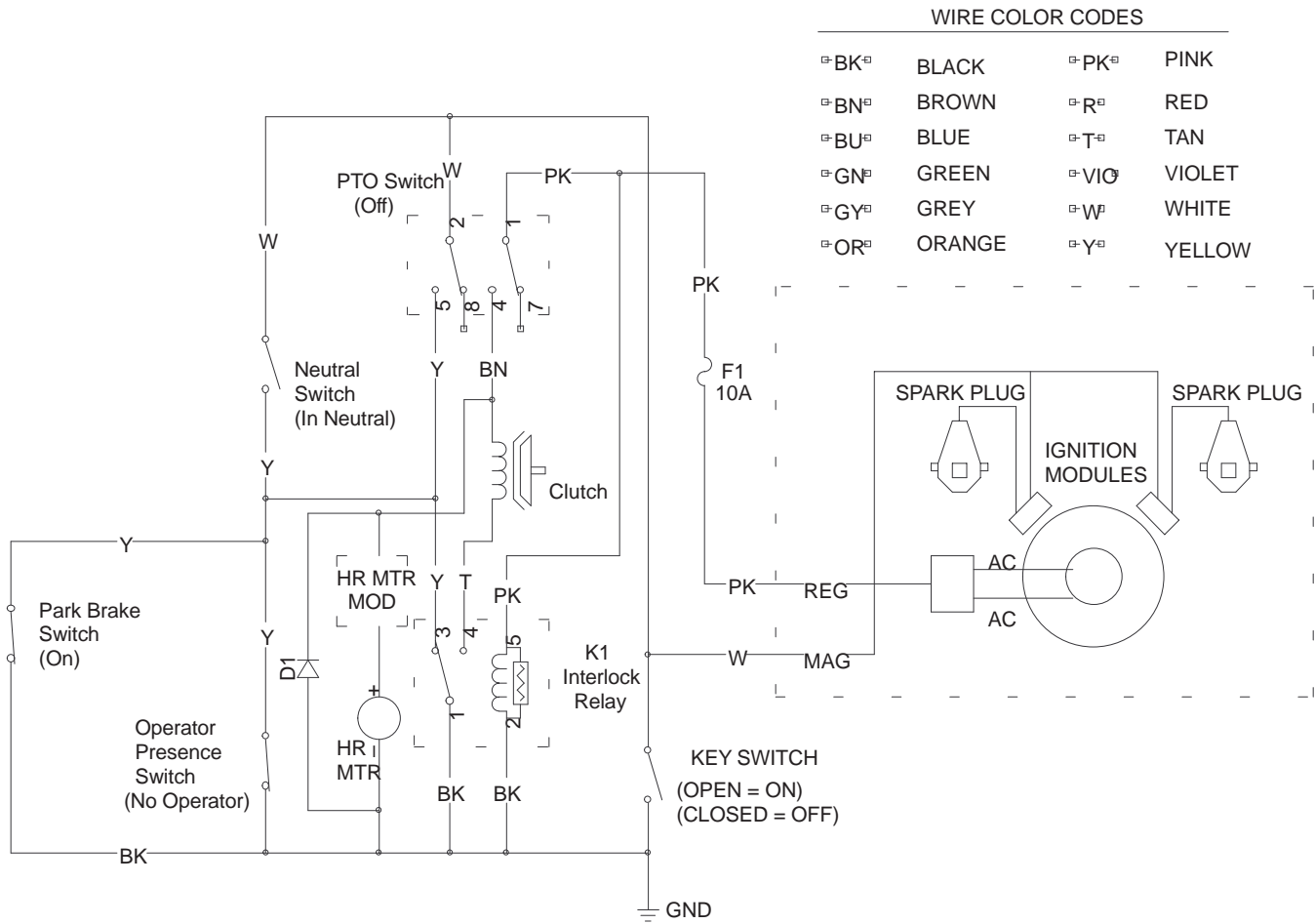

Figure 78

- | | |
|---------------------|---|
| 1. Bolt | 6. Grass Deflector |
| 2. Spacer | 7. L end of spring, place behind deck edge before installing bolt |
| 3. Locknut | 8. J hook end of spring |
| 4. Spring | |
| 5. Spring installed | |

Wiring Diagram



Hydraulic Diagram

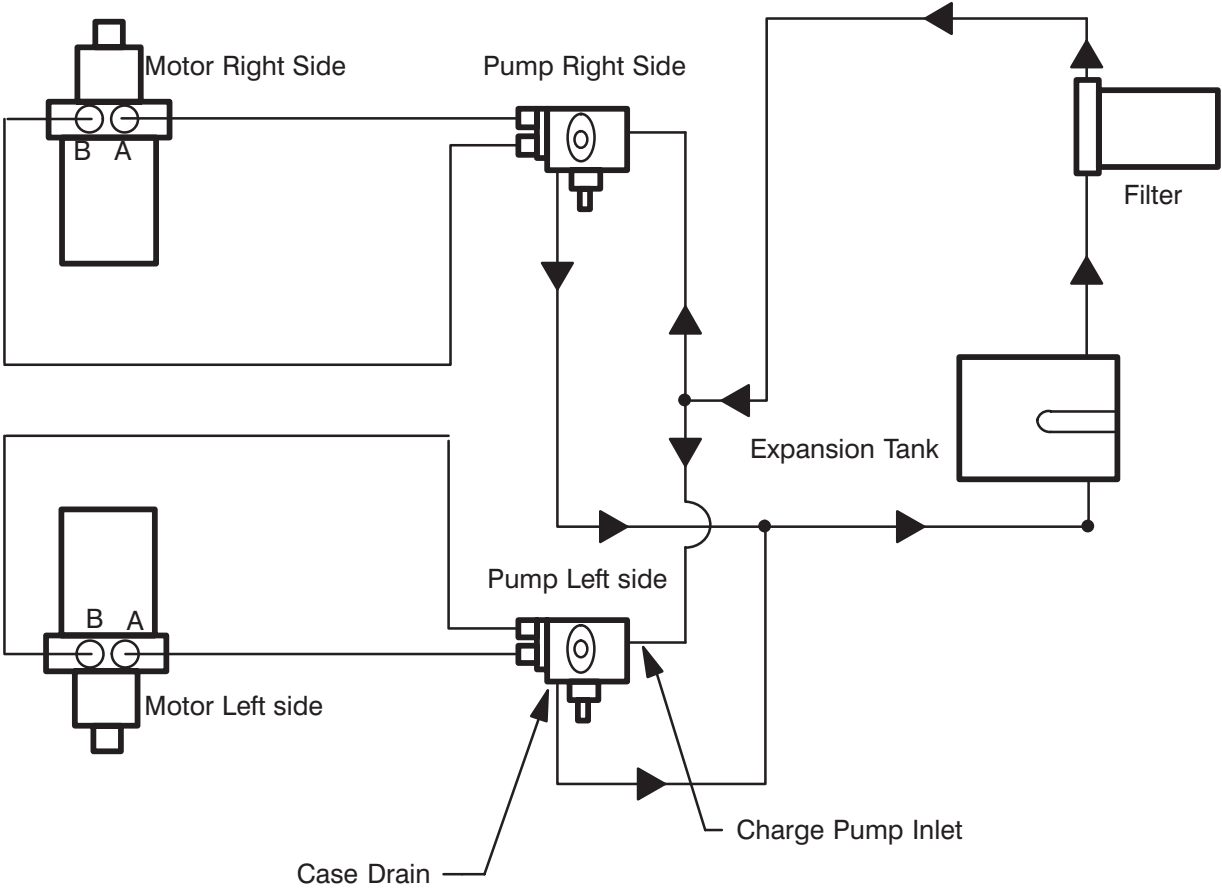

m-5225

Cleaning and Storage

1. Disengage the power take off (PTO) and turn the ignition key to Off to stop the engine. Remove the key.
2. Remove grass clippings, dirt, and grime from the external parts of the entire machine, especially the engine. Clean dirt and chaff from the outside of the engine's cylinder head fins and blower housing.

Important You can wash the machine with mild detergent and water. Do not pressure wash the machine. Avoid excessive use of water, especially near the control panel, engine, hydraulic pumps and motors.

3. Service the air cleaner; refer to Servicing the Air Cleaner, page 27.
4. Change the crankcase oil; refer to Servicing the Engine Oil, page 28.
5. Change the hydraulic filter; refer to Servicing the Hydraulic System on page 33.
6. Check the tire pressure; refer to Checking the Tire Pressure, page 32.
7. For storage over 30 days, prepare the traction unit as follows.
 - A. Add a petroleum based stabilizer/conditioner to fuel in the tank. Follow mixing instructions from stabilizer manufacturer. **Do not use an alcohol based stabilizer (ethanol or methanol).**

Note: A fuel stabilizer/conditioner is most effective when mixed with fresh gasoline and used at all times.

- B. Run the engine to distribute conditioned fuel through the fuel system (5 minutes).
- C. Stop the engine, allow it to cool and drain the fuel tank; refer to Draining the Fuel Tank, page 32.
- D. Restart the engine and run it until it stops.
- E. Choke or prime the engine.
- F. Start and run the engine until it will not start again. Use the primer, if equipped on machine, several times to ensure no fuel remains in primer system.
- G. Dispose of fuel properly. Recycle as per local codes.

Important Do not store stabilizer/conditioned gasoline over 90 days.

8. Remove the spark plug(s) and check its condition; refer to Servicing the Spark Plug on page 29. With the spark plug(s) removed from the engine, pour two tablespoons of engine oil into the spark plug hole. Now use the starter to crank the engine and distribute the oil inside the cylinder. Install the spark plug(s). Do not install the wire on the spark plug(s).
9. Check and tighten all bolts, nuts, and screws. Repair or replace any part that is damaged or defective.
10. Paint all scratched or bare metal surfaces. Paint is available from your Authorized Service Dealer.
11. Store the machine in a clean, dry garage or storage area. Remove the key from the ignition switch and keep it in a memorable place. Cover the machine to protect it and keep it clean.

Troubleshooting

PROBLEM	POSSIBLE CAUSES	CORRECTIVE ACTION
Engine will not start, starts hard, or fails to keep running.	<ol style="list-style-type: none"> 1. Fuel tank is empty. 2. PTO is on (Pulled up). 3. Speed control lever is in gear. 4. Choke is not ON. 5. Air cleaner is dirty. 6. Spark plug wire is loose or disconnected. 7. Spark plug is pitted, fouled, or gap is incorrect. 8. Dirt in fuel filter. 9. Dirt, water, or stale fuel is in fuel system. 	<ol style="list-style-type: none"> 1. Fill fuel tank with gasoline. 2. Turn PTO off (Push in). 3. Move speed control lever to neutral. 4. Move choke lever to ON. 5. Clean or replace air cleaner element. 6. Install wire on spark plug. 7. Install new, correctly gapped spark plug. 8. Replace fuel filter. 9. Contact Authorized Service Dealer.

PROBLEM	POSSIBLE CAUSES	CORRECTIVE ACTION
Engine loses power.	<ol style="list-style-type: none"> 1. Engine load is excessive. 2. Air cleaner is dirty. 3. Oil level in crankcase is low. 4. Cooling fins and air passages under engine blower housing are plugged. 5. Spark plug is pitted, fouled, or gap is incorrect. 6. Vent hole in fuel cap is plugged. 7. Dirt in fuel filter. 8. Dirt, water, or stale fuel is in fuel system. 	<ol style="list-style-type: none"> 1. Reduce ground speed. 2. Clean air cleaner element. 3. Add oil to crankcase. 4. Remove obstruction from cooling fins and air passages. 5. Install new, correctly gapped spark plug. 6. Clean or replace the fuel cap. 7. Replace fuel filter. 8. Contact Authorized Service Dealer.
Engine overheats.	<ol style="list-style-type: none"> 1. Engine load is excessive. 2. Oil level in crankcase is low. 3. Cooling fins and air passages under engine blower housing are plugged. 	<ol style="list-style-type: none"> 1. Reduce ground speed. 2. Add oil to crankcase. 3. Remove obstruction from cooling fins and air passages.
Machine does not drive.	<ol style="list-style-type: none"> 1. Neutral lock is in neutral position. 2. Hydrostatic fluid level low. 3. Traction belt is worn, loose or broken. 4. Traction belt is off pulley. 	<ol style="list-style-type: none"> 1. Move neutral lock to forward position. 2. Fill hydrostatic fluid tank. 3. Change Belt. 4. Install Belt.
Machine does not drive up hills or inclines.	<ol style="list-style-type: none"> 1. By-pass valve is adjusted too far open. 	<ol style="list-style-type: none"> 1. Adjust by-pass valve.
Machine moves slowly in neutral.	<ol style="list-style-type: none"> 1. Neutral is mis-adjusted. 2. Neutral control spring is broken or missing. 	<ol style="list-style-type: none"> 1. Adjust hydro linkages. 2. Replace neutral control spring.
Machine drive is too aggressive.	<ol style="list-style-type: none"> 1. By-pass valve is adjusted too far closed. 	<ol style="list-style-type: none"> 1. Adjust by-pass valve.
Machine tracks left or right.	<ol style="list-style-type: none"> 1. Tire pressure is not correct. 2. Tracking knob not adjusted correctly. 	<ol style="list-style-type: none"> 1. Adjust tire pressure. 2. Adjust tracking knob.

PROBLEM	POSSIBLE CAUSES	CORRECTIVE ACTION
Abnormal vibration.	<ol style="list-style-type: none"> 1. Cutting blade(s) is/are bent or unbalanced. 2. Blade mounting bolt is loose. 3. Engine mounting bolts are loose. 4. Loose engine pulley, idler pulley, or blade pulley. 5. Engine pulley is damaged. 6. Blade spindle bent. 	<ol style="list-style-type: none"> 1. Install new cutting blade(s). 2. Tighten blade mounting bolt. 3. Tighten engine mounting bolts. 4. Tighten the appropriate pulley. 5. Contact Authorized Service Dealer. 6. Contact Authorized Service Dealer.
Uneven cutting height.	<ol style="list-style-type: none"> 1. Blade(s) not sharp. 2. Cutting blade(s) is/are bent. 3. Mower is not level. 4. Underside of mower is dirty. 5. Tire pressure is incorrect. 6. Blade spindle bent. 	<ol style="list-style-type: none"> 1. Sharpen blade(s). 2. Install new cutting blade(s). 3. Level mower from side-to-side and front-to-rear. 4. Clean the underside of the mower. 5. Adjust tire pressure. 6. Contact Authorized Service Dealer.
Blades do not rotate.	<ol style="list-style-type: none"> 1. PTO Drive belt is worn, loose or broken. 2. PTO Drive belt is off pulley. 3. Deck belt is worn, loose or broken. 4. Deck belt is off pulley. 	<ol style="list-style-type: none"> 1. Install new drive belt. 2. Install drive belt and check adjusting shafts and belt guides for correct position. 3. Install new deck belt. 4. Install deck pulley and check the idler pulley, idler arm and spring for correct position and function.



LCE

The Toro Total Coverage Guarantee

A Limited Warranty

Conditions and Products Covered

The Toro Company and its affiliate, Toro Warranty Company, pursuant to an agreement between them, jointly promise to repair the listed Toro Products if defective in materials or workmanship. The following time periods apply from the date of purchase:

<u>Products</u>	<u>Warranty Period</u>
• All Products	1 year
• All Spindles	2 years parts and labor; third year, parts only
• Engines/Hydraulic Systems* on the following: Outfront and Mid-Mount Z's ProLine Mid-Size Mowers Groundsmaster® Riding Mowers Backpack Blowers	2 years
• Deck Shells (36"-72") on the following: ProLine Mid-Size Mowers Mid-Mount Z's	2 years
• Electric Clutch on 200 Series Mid-Mount Z's	2 years

This warranty includes the cost of parts and labor, but you must pay transportation costs.

This warranty applies to:

- Outfront and Mid-Mount Z's
- ProLine Mid-Size Mowers
- Groundsmaster Riding Mowers
- Turf Maintenance Equipment
- Debris Management Equipment

* Some engines used on Toro LCE Products are warranted by the engine manufacturer.

Instructions for Obtaining Warranty Service

If you think that your Toro Product contains a defect in materials or workmanship, follow this procedure:

1. Contact any Toro Authorized or Master Service Dealer to arrange service at their dealership. To locate a dealer convenient to you, access our website at www.Toro.com. U.S. Customers may also call 800-348-2424.
2. Bring the product and your proof of purchase (sales receipt) to the Service Dealer.

If for any reason you are dissatisfied with the Service Dealer's analysis or with the assistance provided, contact us at:

LCB Customer Service Department
Toro Warranty Company
8111 Lyndale Avenue South
Bloomington, MN 55420-1196
888-577-7466 (U.S. customers)
877-484-9255 (Canada customers)

Countries Other than the United States or Canada

Customers who have purchased Toro products exported from the United States or Canada should contact their Toro Distributor (Dealer) to obtain guarantee policies for your country, province, or state. If for any reason you are dissatisfied with your Distributor's service or have difficulty obtaining guarantee information, contact the Toro importer. If all other remedies fail, you may contact us at Toro Warranty Company.

Owner Responsibilities

You must maintain your Toro Product by following the maintenance procedures described in the operator's manual. Such routine maintenance, whether performed by a dealer or by you, is at your expense.

Items and Conditions Not Covered

There is no other express warranty except for special emission system coverage on some products. This express warranty does not cover the following:

- Cost of regular maintenance service or parts, such as filters, fuel, lubricants, tune-up parts, blade sharpening, brake and clutch adjustments.
- Any product or part which has been altered or misused or required replacement or repair due to normal wear, accidents, or lack of proper maintenance.
- Repairs necessary due to improper fuel, contaminants in the fuel system, or failure to properly prepare the fuel system prior to any period of non-use over three months.
- Pickup and delivery charges.

All repairs covered by this warranty must be performed by an Authorized Toro Service Dealer using Toro approved replacement parts.

General Conditions

Repair by an Authorized Toro Service Dealer is your sole remedy under this warranty.

Neither The Toro Company nor Toro Warranty Company is liable for indirect, incidental or consequential damages in connection with the use of the Toro Products covered by this warranty, including any cost or expense of providing substitute equipment or service during reasonable periods of malfunction or non-use pending completion of repairs under this warranty.

Some states do not allow exclusions of incidental or consequential damages, or limitations on how long an implied warranty lasts, so the above exclusions and limitations may not apply to you.

All implied warranties of merchantability (that the product is fit for ordinary use) and fitness for use (that the product is fit for a particular purpose) are limited to the duration of the express warranty.

This warranty gives you specific legal rights, and you may also have other rights which vary from state to state.