



**Count on it.**

**Parts Catalog**

**TX 700**

**Narrow Track Compact Tool Carrier**

Model No. 22750—Serial No. 40000000 and Up



# Ordering Replacement Parts

To order replacement parts, please supply the part number, the quantity, and the description of each part desired.

## Understanding Reference Numbers

Each identified part in an illustration has a reference number. The reference number for a part also appears in the parts list, along with other information about the part.

This catalog uses two special reference number formats, one to indicate parts in a service assembly and another to indicate the quantity of a given part in an illustration.

## Service Assembly Reference Numbers

Parts in service assemblies have reference numbers in the form a:b. The a represents the reference number of the entire service assembly and the b represents a sequential number unique to each part within the service assembly.

For example, a wheel assembly might be identified by reference number 6, the tire by 6:1, the valve by 6:2, and the wheel by 6:3. When you order the assembly identified by reference number 6, you receive all parts identified by reference numbers 6:1, 6:2, and 6:3. However, you may also order any part individually. Reference numbers of this type appear in illustration and in parts lists.

## Reference Numbers Indicating Quantity

In an illustration, if a reference number indicates more than one part, the reference number has the form nX y. The n represents the quantity of the part, the X is the multiplication symbol, and the y represents the reference number.

For example, in an illustration, the reference number 2X 37 means that two of the parts identified by reference number 37 are indicated.

# Contents

Frame Assembly	4
Main Frame Assembly No. 163-3244	6
Track Assembly	8
RH Track Assembly No. 139-7293	10
LH Track Assembly No. 139-7294	12
Parking Brake Assembly	14
Traction Hydraulic Assembly	16
Radiator and Air Cleaner Assembly	18
Air Cleaner Assembly No. 117-9989	20
Engine and Pump Assembly	22
Hydraulic Pump Assembly No. 140-3048	24
Hydraulic Assembly	26
Traction Control Assembly No. 140-2940	28
Control Valve Assembly No. 145-3279	30
Loader Arm Assembly	32
Loader Arm Assembly No. 145-3225	34
Hydraulic Cylinder Assembly No. 140-2974	36
Loader Arm Hydraulic Assembly	38
Quick Attach Assembly	40
Quick Attach Assembly No. 132-8418	42
Hydraulic Cylinder Assembly No. 145-3202	44
Fuel Assembly	46
Fuel Tank Assembly No. 140-5762	48
Hood and Manual Tube Assembly	50
Platform Assembly	52
Electrical Assembly	54
Main Wire Harness Assembly No. 122-3946	56
Attachments and Accessories	58

# Frame Assembly

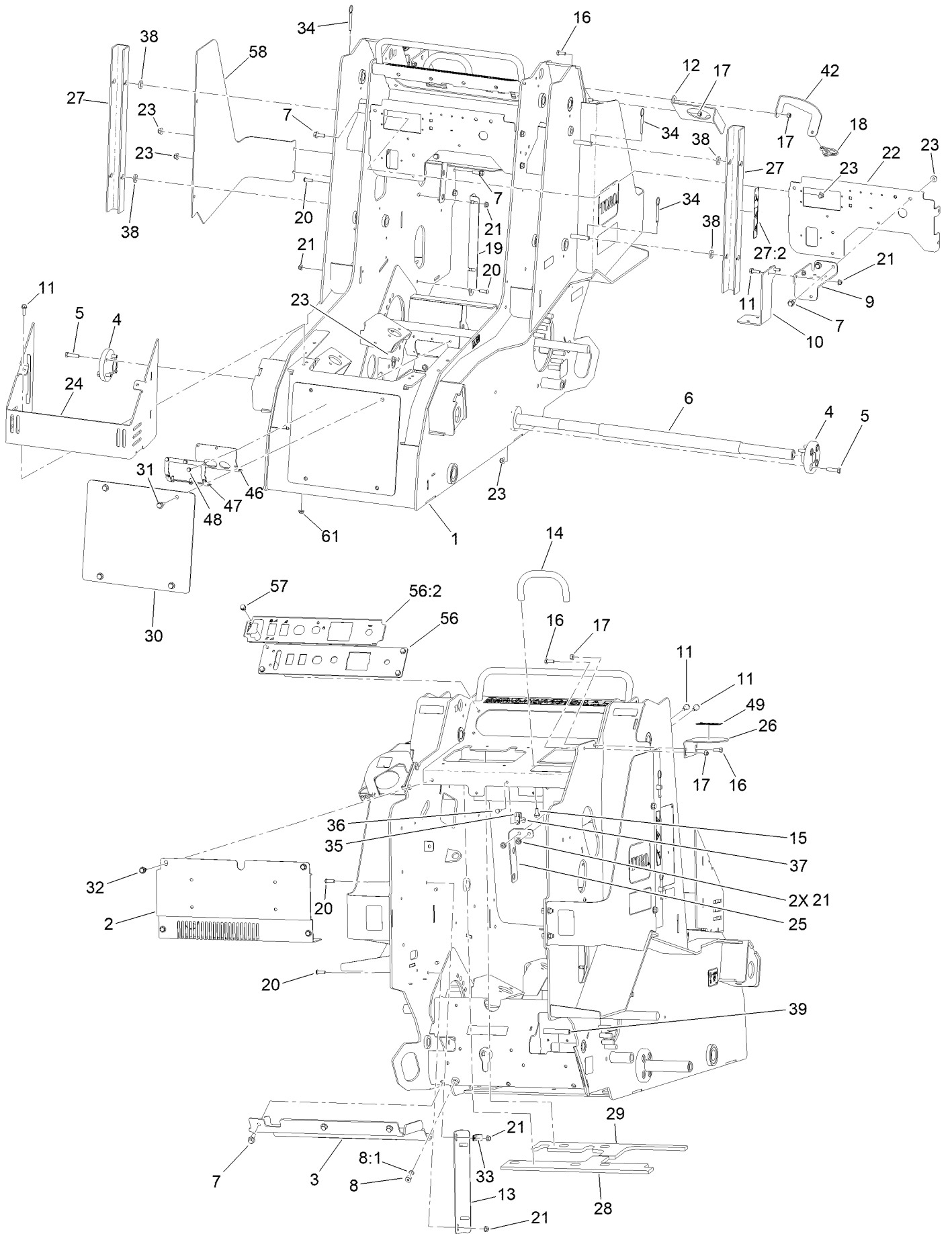

## Frame Assembly (continued)

<i>Ref.</i>	<i>Part Number</i>	<i>Qty.</i>	<i>Description</i>	<i>Ref.</i>	<i>Part Number</i>	<i>Qty.</i>	<i>Description</i>
1	163-3244	1	Main Frame ASM	26	147-9010-05	1	Cap-Cover
2	144-6085-05	1	Air Box [blk-Txt]	27	130-5315	2	Arm-Locking
3	147-9024-01	1	Plate-Bottom, Frame	27:2	115-4858	1	Decal-Danger
4	132-9074	2	Hub-Shaft	28	163-3209	1	Foam-Heat Shield
5	323-8	8	Screw-HH	29	163-3208	1	Foam-Heat Shield
6	125-0425	1	Shaft-Track	30	163-3239-01	1	Cover-Front
7	3234-42	13	Screw-HHF	31	3234-24	4	Screw-HHF
8	353-989	1	Plug-Hex, Hollow	32	105-6245	4	Screw-Tapping
8:1	237-42	1	O-Ring	33	92-6064	1	Clamp-R
9	145-3332-01	1	Bracket-Tank	34	108-0094	4	Pin-Cotterless
10	140-2923-01	1	Bracket-Tank	35	2412-134	1	Clamp-R
11	3234-17	8	Screw-HHF	36	321-5	1	Screw-HH
12	144-6068-05	1	Bracket-Fuel	37	32128-33	1	Nut-HF
13	140-5734-03	1	Angle	38	83-1470	4	Washer-Neoprene
14	112-2620	1	Bar-Reference	39	144-6078	1	Trim
15	3234-5	2	Screw-HHF	42	130-5317	1	Plate-Lock, Fuel Cap, RH
16	322-4	4	Screw-HH	46	145-3270	1	Air - Guard
17	3296-29	4	Nut-Lock, NI	47	145-3271	1	Retaining - Ring
18	145-3228	1	Pin-Lynch	48	32144-4	7	Screw-HWH
19	140-5735-03	1	Angle	49	125-8483	1	Decal-HYD Fluid
20	109-4872	4	Screw-HSH	56	163-3242	1	Plate-Console (Service)
21	104-8300	8	Nut-HF, NI	56:2	161-9441	1	Decal-Controls
22	161-6934-01	1	Plate-Console Cover, Front	57	700057	4	Screw-HWH
23	104-8301	18	Nut-HF, NI	58	163-3246	1	Wrap-Tank, RH
24	161-6914-05	1	Shield-Front, ASM	61	32128-20	4	Nut-HF
25	140-2924-03	1	Bracket-Tank				

# Main Frame Assembly No. 163-3244

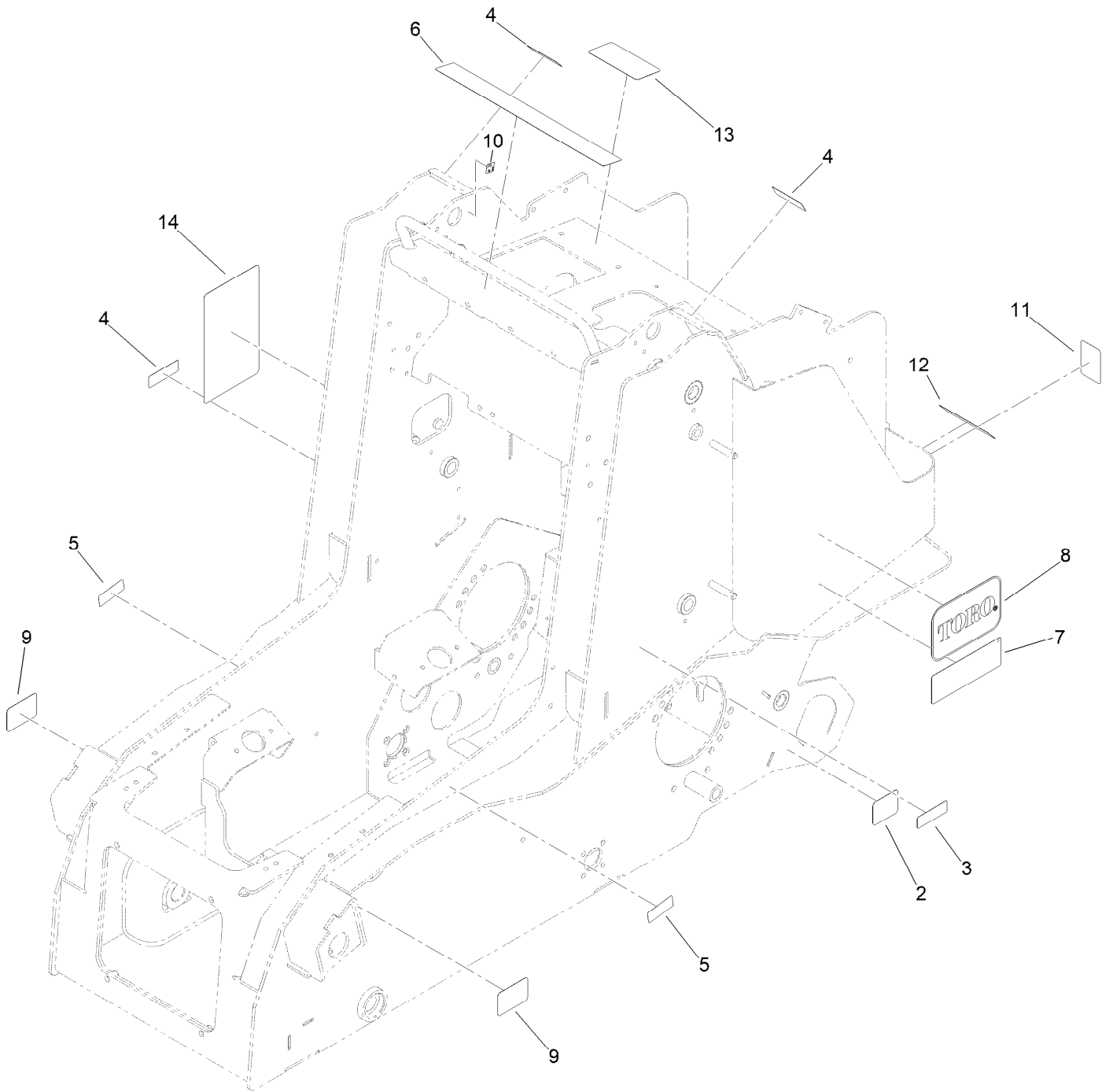

## Main Frame Assembly No. 163-3244 (continued)

<i>Ref.</i>	<i>Part Number</i>	<i>Qty.</i>	<i>Description</i>	<i>Ref.</i>	<i>Part Number</i>	<i>Qty.</i>	<i>Description</i>
2	125-6694	2	Decal-Tie Down	9	125-6139	2	Decal-Lift/Tie Down
3	133-8062	1	Decal-Spark Arrestor	10	93-9084	2	Decal-Point, Lift
4	120-0625	4	Decal-Warning	11	100-4627	1	Reflector
5	115-2047	2	Decal-Surface, Hot	12	131-0709	1	Decal-Parking Brake
6	145-0637	1	Decal-Safety	13	161-9449	1	Decal-Awd
7	140-5790	1	Decal-Dingo Tx700	14	163-8679	1	Decal-Service
8	145-0609	1	Decal-Toro Logo				

# Track Assembly

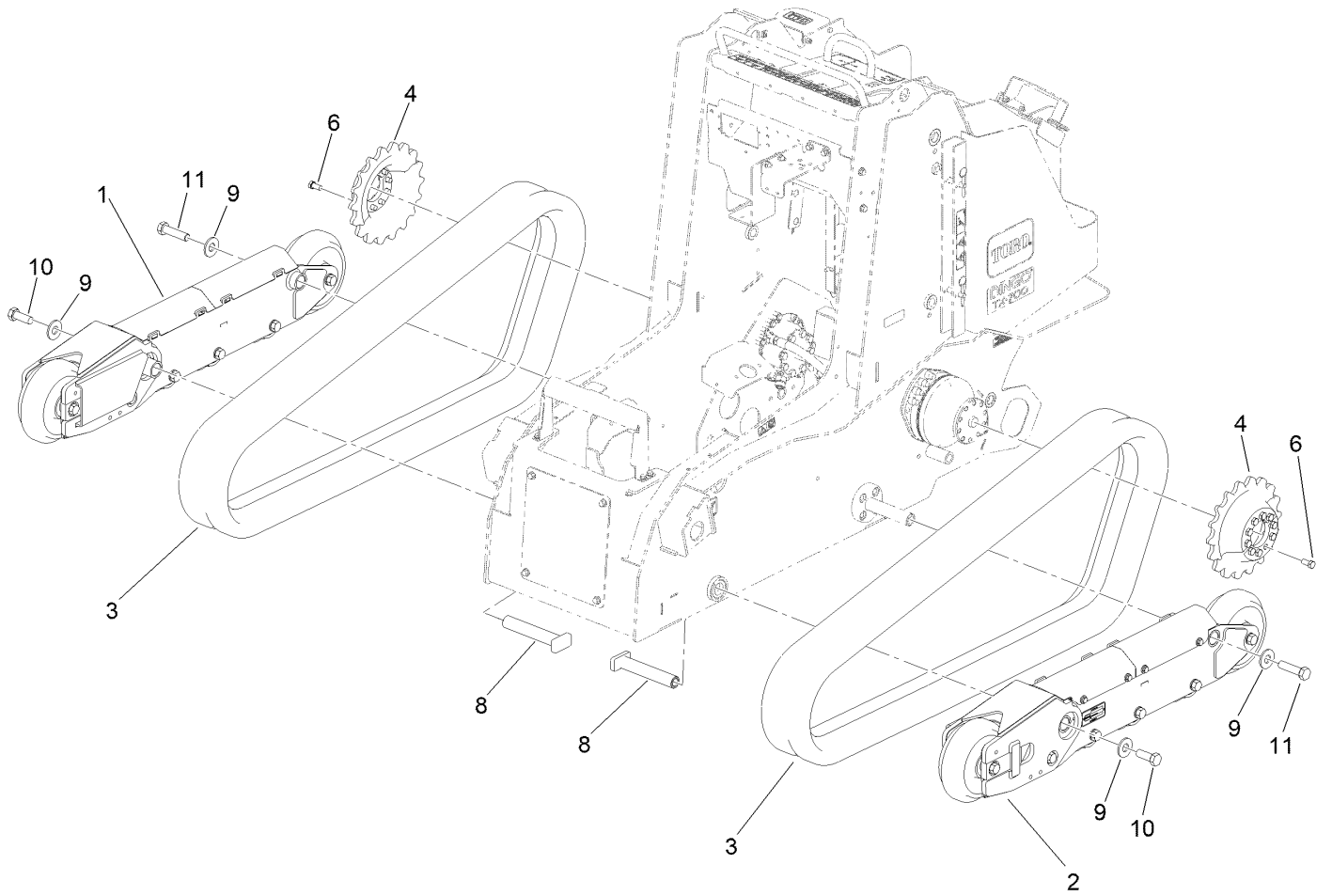

## Track Assembly (continued)

<i>Ref.</i>	<i>Part Number</i>	<i>Qty.</i>	<i>Description</i>	<i>Ref.</i>	<i>Part Number</i>	<i>Qty.</i>	<i>Description</i>
1	139-7293	1	Track ASM-RH	8	145-3322	2	Pin-Track
2	139-7294	1	Track ASM-LH	9	99-2659	4	Washer
3	138-0804	2	Track-Narrow	10	AU426-1232	2	Bolt
4	145-4463	4	Sprocket-Drive, Nt	11	328-25	2	Screw-HH
6	33116-025	20	Screw-HH				

# RH Track Assembly No. 139-7293

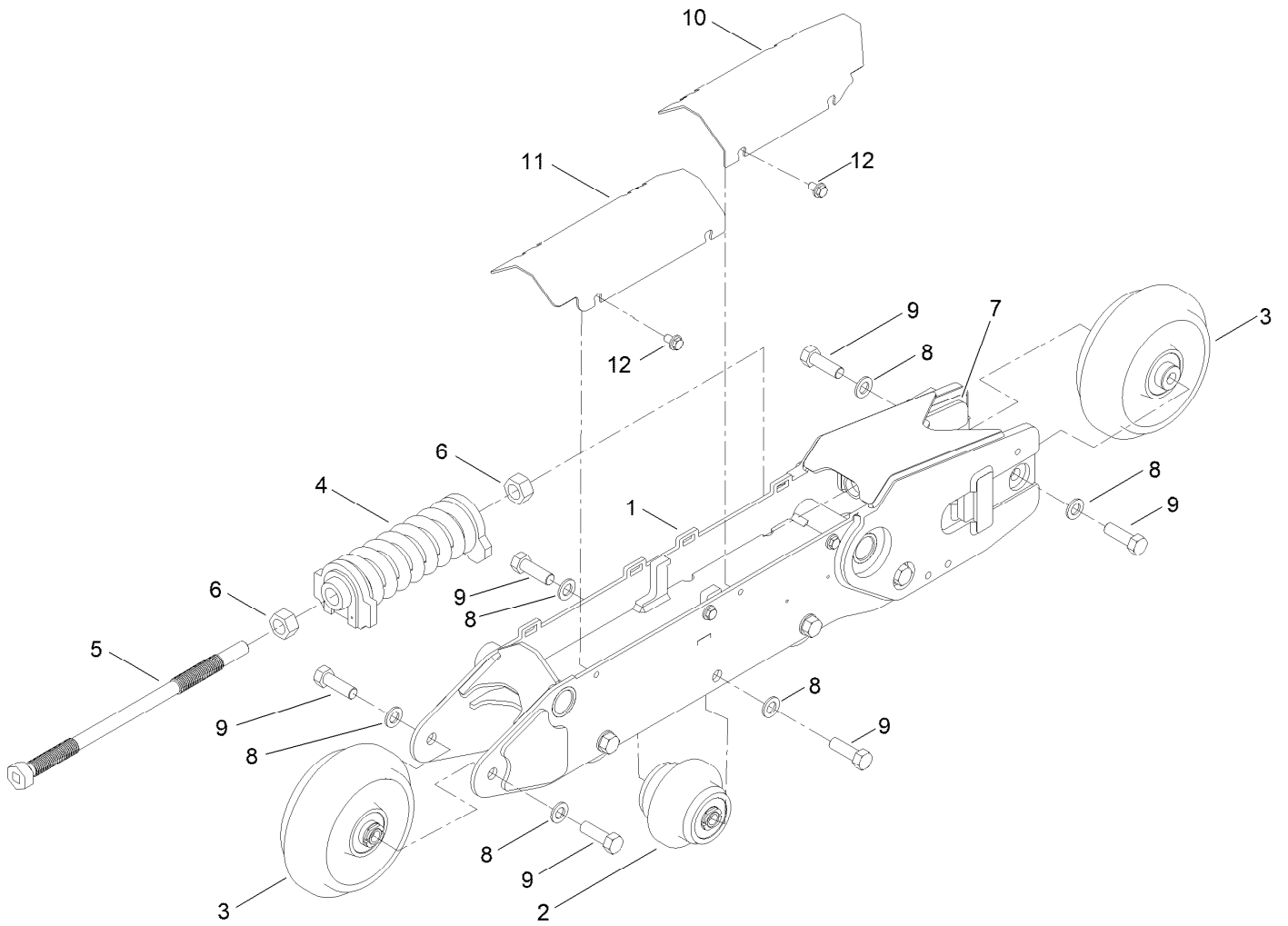

## RH Track Assembly No. 139-7293 (continued)

<i>Ref.</i>	<i>Part Number</i>	<i>Qty.</i>	<i>Description</i>	<i>Ref.</i>	<i>Part Number</i>	<i>Qty.</i>	<i>Description</i>
1	139-7292	1	Frame-Track RH	7	139-7301	1	Yoke-Tensioner
2	137-8808	4	Wheel ASM,	8	139-7310	12	Washer
3	137-8807	2	Tensioner Wheel ASM	9	111-3484	12	Screw-HH
4	140-5872	1	Kit-Spring Tension	10	139-7311	1	Plate-Cover RH
5	139-7298	1	Screw-Tensioner	11	139-7312	1	Plate-Cover RH
6	3217-15	2	Nut-Hex	12	63-11-019	4	Screw-HHF

# LH Track Assembly No. 139-7294

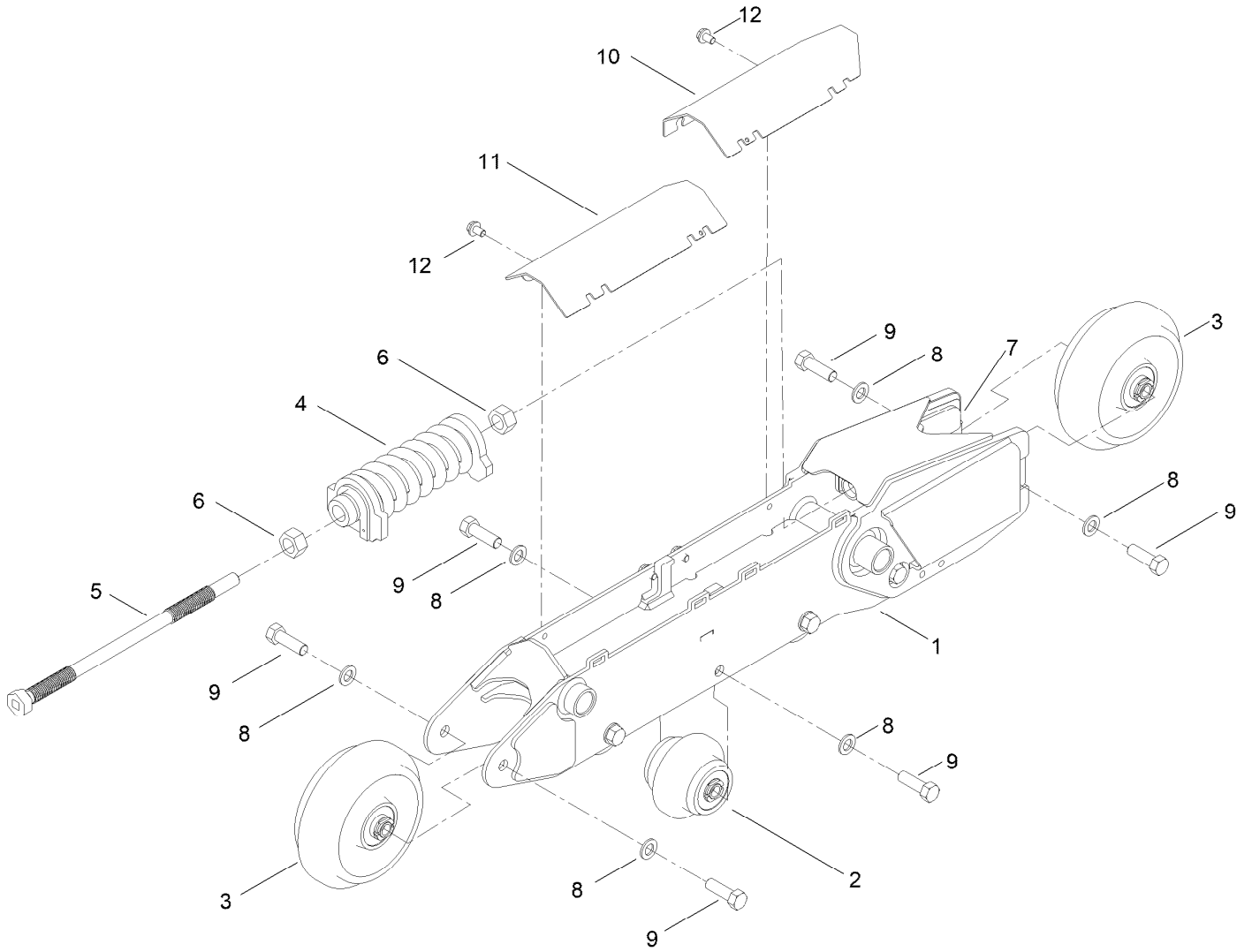

# LH Track Assembly No. 139-7294 (continued)

<i>Ref.</i>	<i>Part Number</i>	<i>Qty.</i>	<i>Description</i>	<i>Ref.</i>	<i>Part Number</i>	<i>Qty.</i>	<i>Description</i>
1	139-7303	1	Frame-Track LH	7	139-7301	1	Yoke-Tensioner
2	137-8808	4	Wheel ASM,	8	139-7310	12	Washer
3	137-8807	2	Tensioner Wheel ASM	9	111-3484	12	Screw-HH
4	140-5872	1	Kit-Spring Tension	10	139-7304	1	Plate-Cover LH
5	139-7298	1	Screw-Tensioner	11	139-7305	1	Plate-Cover LH
6	3217-15	2	Nut-Hex	12	63-11-019	4	Screw-HHF

# Parking Brake Assembly

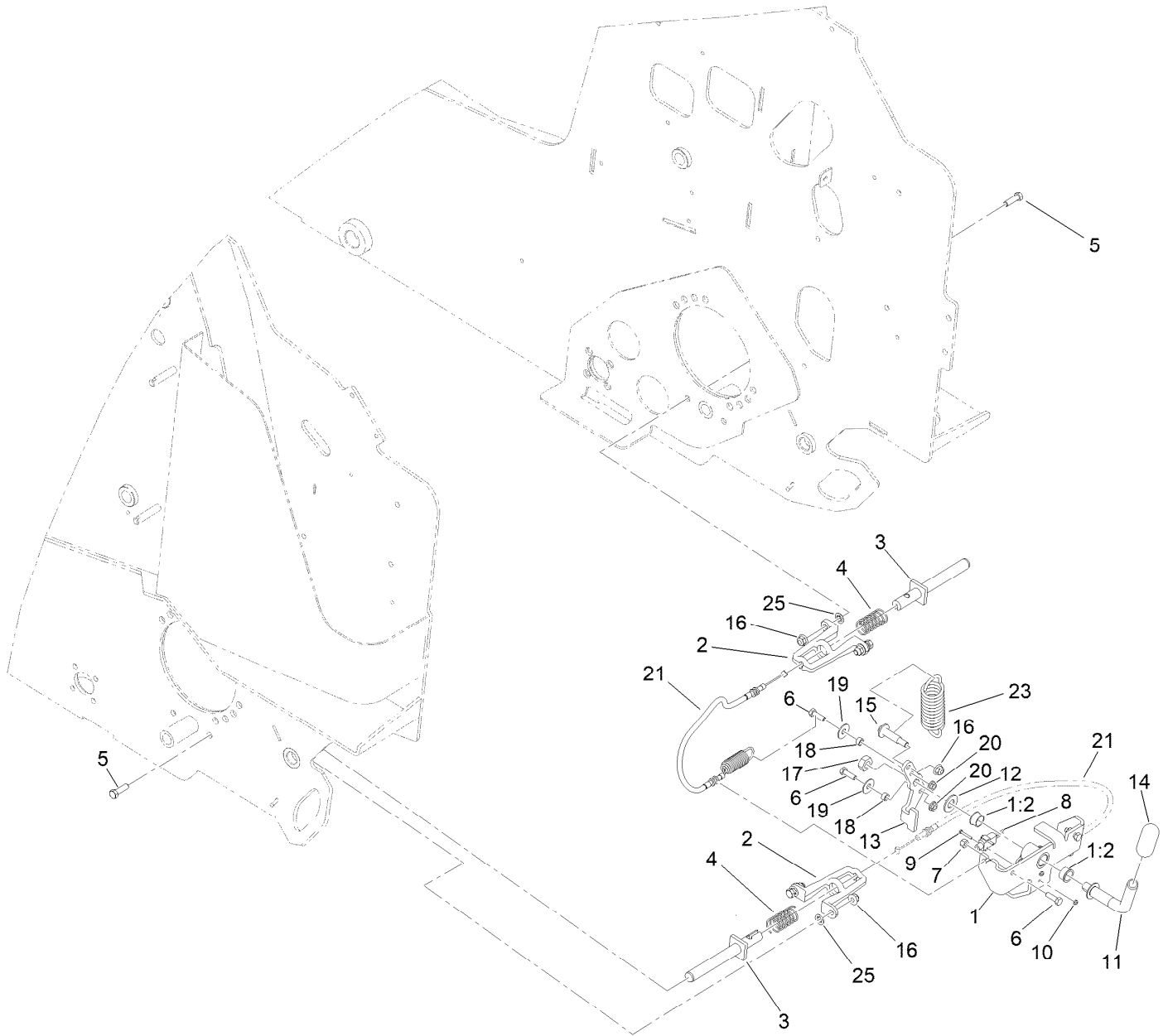

## Parking Brake Assembly (continued)

<i>Ref.</i>	<i>Part Number</i>	<i>Qty.</i>	<i>Description</i>	<i>Ref.</i>	<i>Part Number</i>	<i>Qty.</i>	<i>Description</i>
1	145-3171	1	Brake Bracket ASM	12	3256-27	1	Washer-Flat
1:2	256-252	2	Bearing-Flange	13	138-0205-0P	1	Plate-Brake Linkage
2	138-0207-03	2	Mount-Pin [black]	14	110-1037	1	Grip-Handle
3	144-2137	2	Brake Rod ASM	15	136-7198	1	Bolt-Shoulder
4	125-0344	2	Spring-Compression	16	104-8301	5	Nut-HF, NI
5	323-7	4	Screw-HH	17	3296-33	1	Nut-Lock, NI
6	323-5	4	Screw-HH	18	85-9120	2	Spacer-Pivot, Tilt
7	3296-29	2	Nut-Lock, NI	19	52-2860	2	Washer
8	95-8900	1	Switch	20	32128-20	2	Nut-HF
9	32105-9	2	Screw-HH	21	136-4789	2	Cable-Brake
10	3296-9	2	Nut-Hex	23	136-4787	1	Spring-EXT
11	133-0232	1	Lever-Brake	25	107-3154	4	Nut-Push

# Traction Hydraulic Assembly

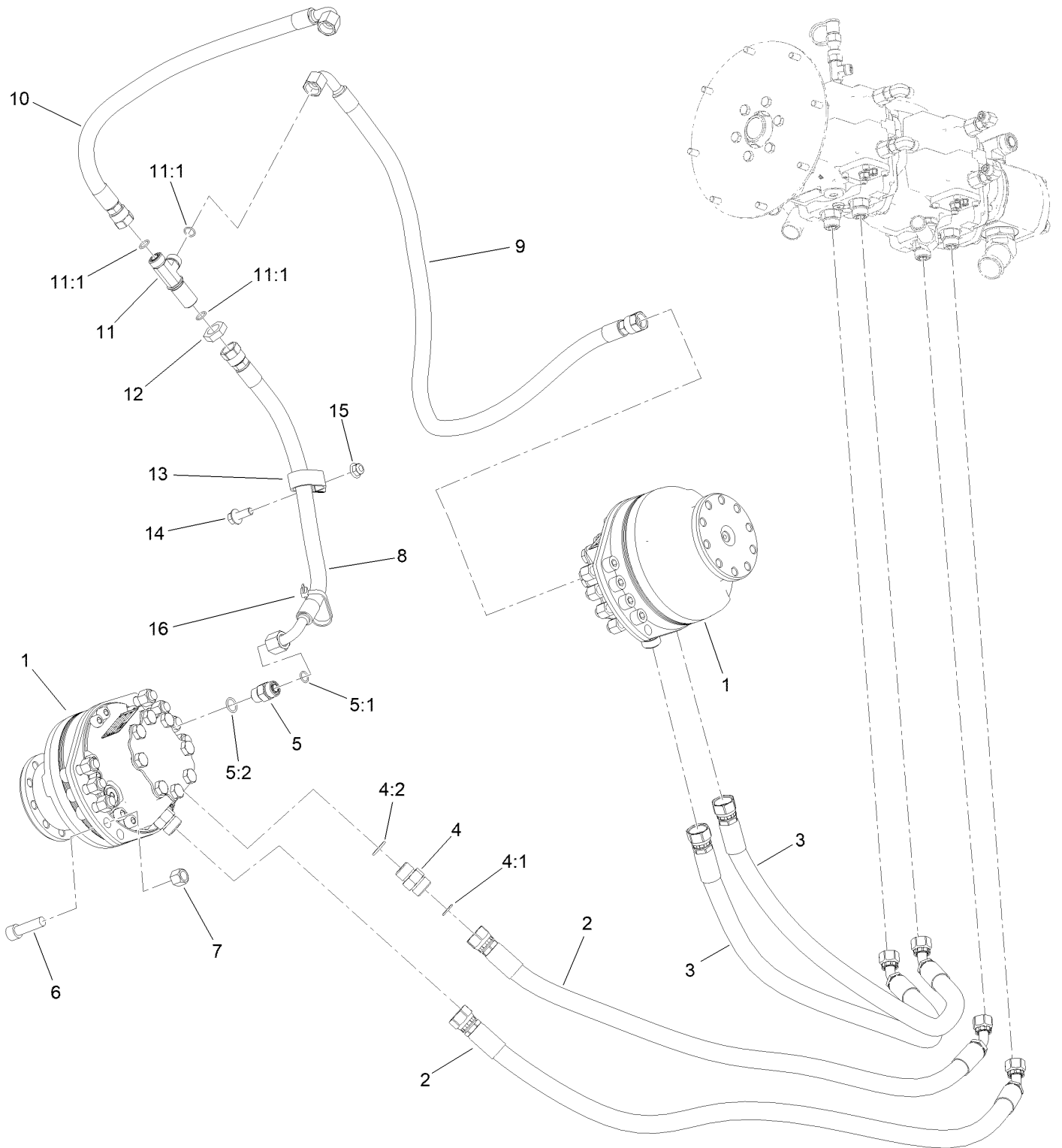

## Traction Hydraulic Assembly (continued)

<i>Ref.</i>	<i>Part Number</i>	<i>Qty.</i>	<i>Description</i>	<i>Ref.</i>	<i>Part Number</i>	<i>Qty.</i>	<i>Description</i>
1	145-4427	2	Wheelmotor ASM	8	145-3310	1	Hose ASM-HYD
2	140-2874	2	Hose ASM-HYD	9	145-3311	1	Hose ASM-HYD
3	140-2913	2	Hose ASM-HYD	10	145-3312	1	Hose ASM-HYD
4	340-7	4	Fitting-Straight	11	340-121	1	Fitting-Tee
4:1	237-65	1	O-Ring	11:1	237-30	3	O-Ring
4:2	237-80	1	O-Ring	12	340-127	1	Nut-Bulkhead
5	340-4	2	Fitting-Straight	13	2412-137	1	Clamp-R, Double
5:1	237-30	1	O-Ring	14	3234-42	1	Screw-HHF
5:2	237-79	1	O-Ring	15	104-8301	1	Nut-HF, NI
6	131-0661	16	Screw-HSH	16	3334-945	1	Tie-Cable
7	3296-23	16	Nut-Lock, NI				

# Radiator and Air Cleaner Assembly

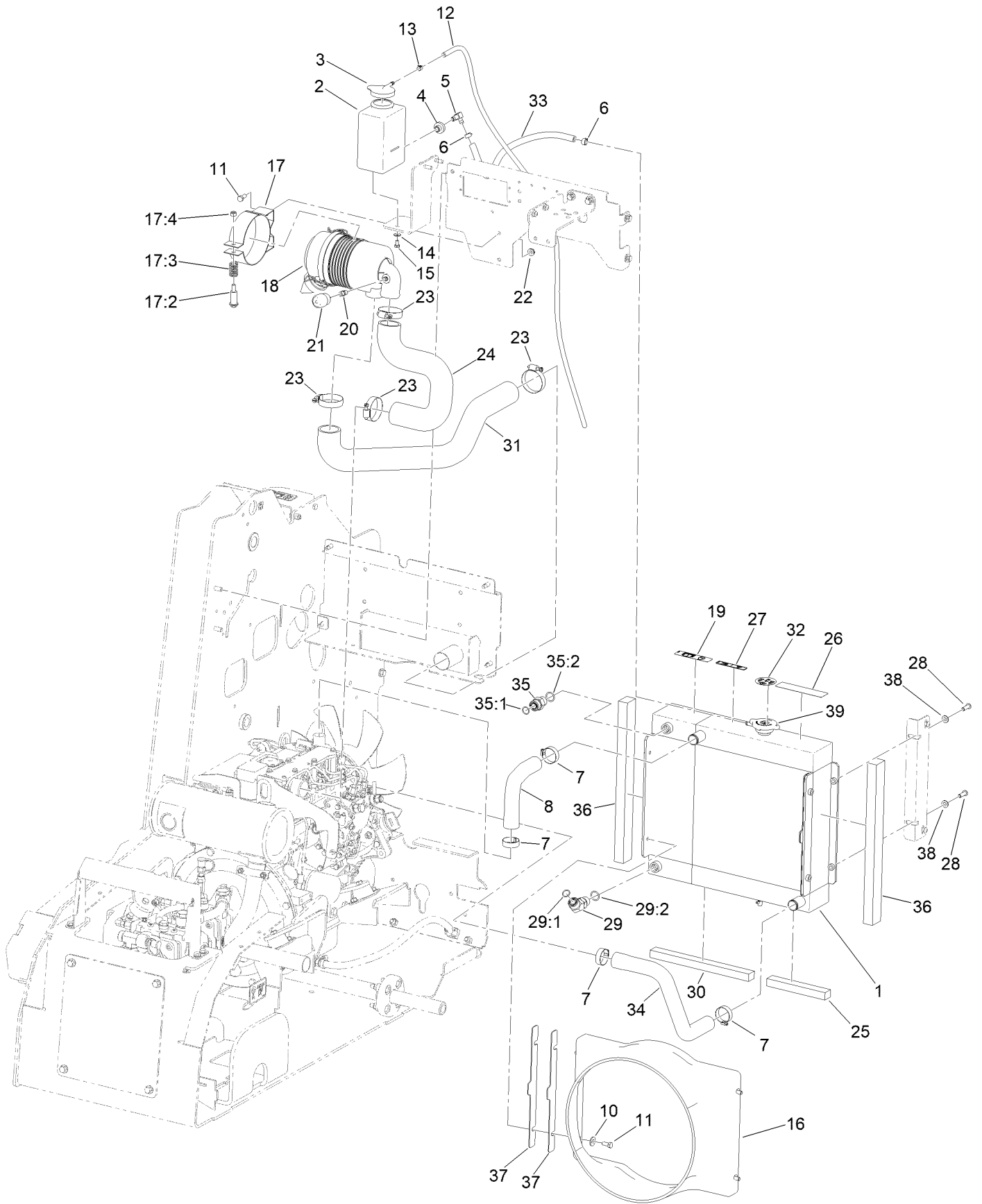

## Radiator and Air Cleaner Assembly (continued)

<i>Ref.</i>	<i>Part Number</i>	<i>Qty.</i>	<i>Description</i>	<i>Ref.</i>	<i>Part Number</i>	<i>Qty.</i>	<i>Description</i>
1	140-2852	1	Rad/Oil Cooler	21:1	94-1416	1	Adapter-Indicator ●
2	1-643163	1	Tank-Overflow	22	32128-20	2	Nut-HF
3	1-643164	1	Cap-Tank, Overflow	23	2412-92	4	Clamp-Hose
4	46-6560	1	Bushing	24	140-2856	1	Hose-Air, Inlet
5	46-6550	1	Fitting-Elbow, 90 DEG	25	144-2132	1	Foam-Radiator Bottom LH
6	92-2379	2	Clamp-Hose	26	93-7814	1	Decal-Danger
7	2412-34	4	Clamp-Hose	27	93-6681	1	Decal-Warning, Fan
8	140-2858	1	Hose-Radiator, Upper	28	109-4872	4	Screw-HSH
10	3256-3	4	Washer-Flat	29	340-14	1	Fitting-HYD, 45 DEG
11	322-3	6	Screw-HH	29:1	237-65	1	O-Ring
12	108-9698	1	Hose-Fuel	29:2	237-80	1	O-Ring
13	2412-80	1	Clamp-Hose	30	144-2131	1	Foam-Radiator Bottom RH
14	3256-22	2	Washer-Flat	31	144-6082	1	Hose-Air, Inlet
15	321-2	2	Screw-HH	32	117-3276	1	Decal-Danger
16	140-5745	1	Shroud-Fan	33	110-3257	1	Hose-Fuel
17	93-2191	1	Air Cleaner Mounting Band ASM	34	140-2857	1	Hose-Radiator, Lower
17:2	94-3653	1	Bolt	35	340-7	1	Fitting-Straight
17:3	94-3654	1	Spring	35:1	237-65	1	O-Ring
17:4	33024-00	1	Nut-Lock, NI	35:2	237-80	1	O-Ring
18	117-9989	1	Air Cleaner ASM	36	144-2130	2	Foam-Radiator Side
19	115-4865	1	Decal-Fill, Radiator	37	145-3326	2	Spacer-Radiator
20	105-4292	1	Nipple-Pipe	38	3256-23	2	Washer-Plain
21	104-3563	1	Indicator	39	161-9418	1	Cap-Radiator

● Not illustrated

# Air Cleaner Assembly No. 117-9989

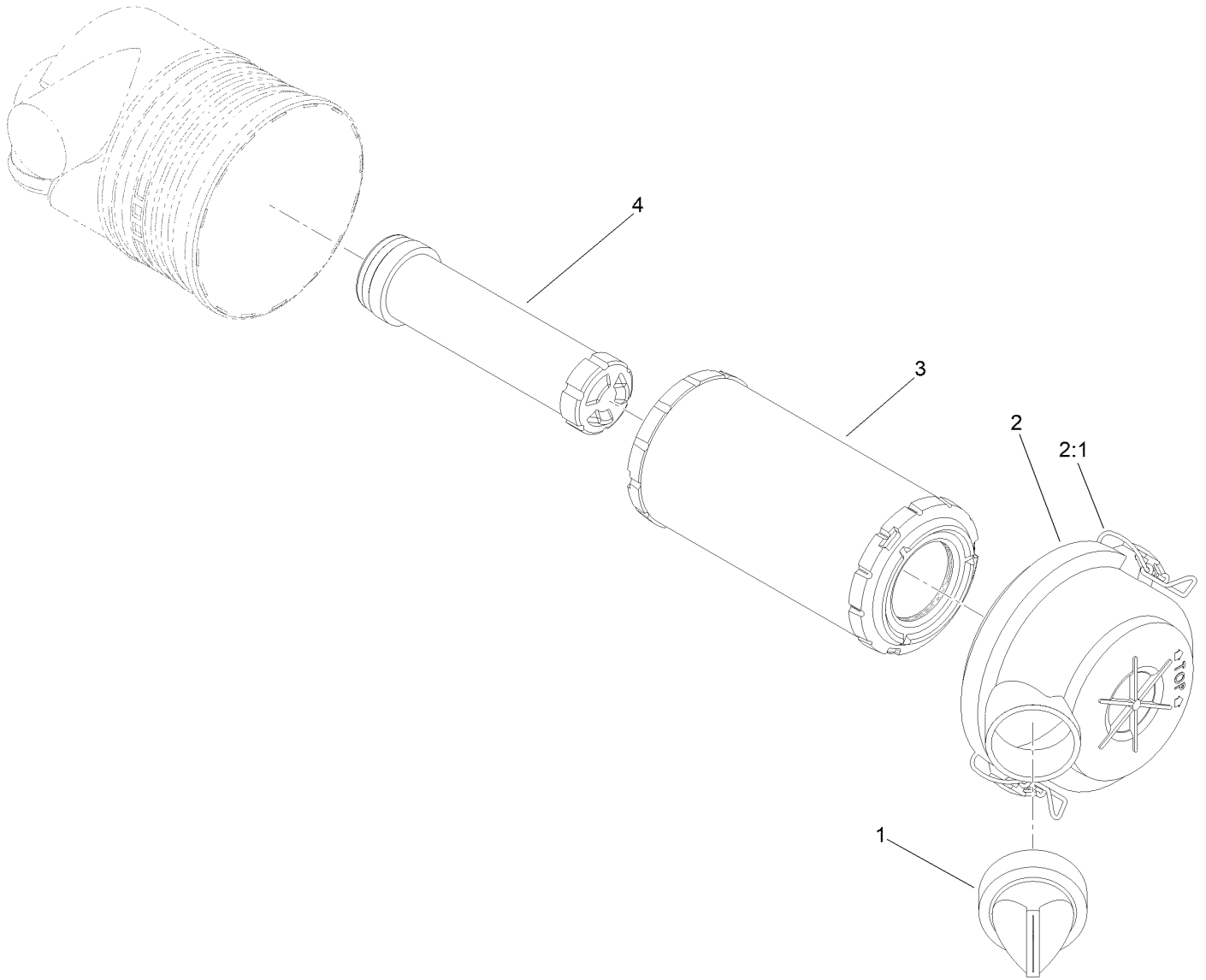

## Air Cleaner Assembly No. 117-9989 (continued)

<i>Ref.</i>	<i>Part Number</i>	<i>Qty.</i>	<i>Description</i>	<i>Ref.</i>	<i>Part Number</i>	<i>Qty.</i>	<i>Description</i>
1	87-9400	1	Valve-Vacuator	3	108-3811	1	Filter-Air V-Twin HD
2	94-3652	1	Cover ASM	4	98-2982	1	Filter-Element, Safety
2:1	1-643283	2	Latch-Cleaner, Air				

# Engine and Pump Assembly

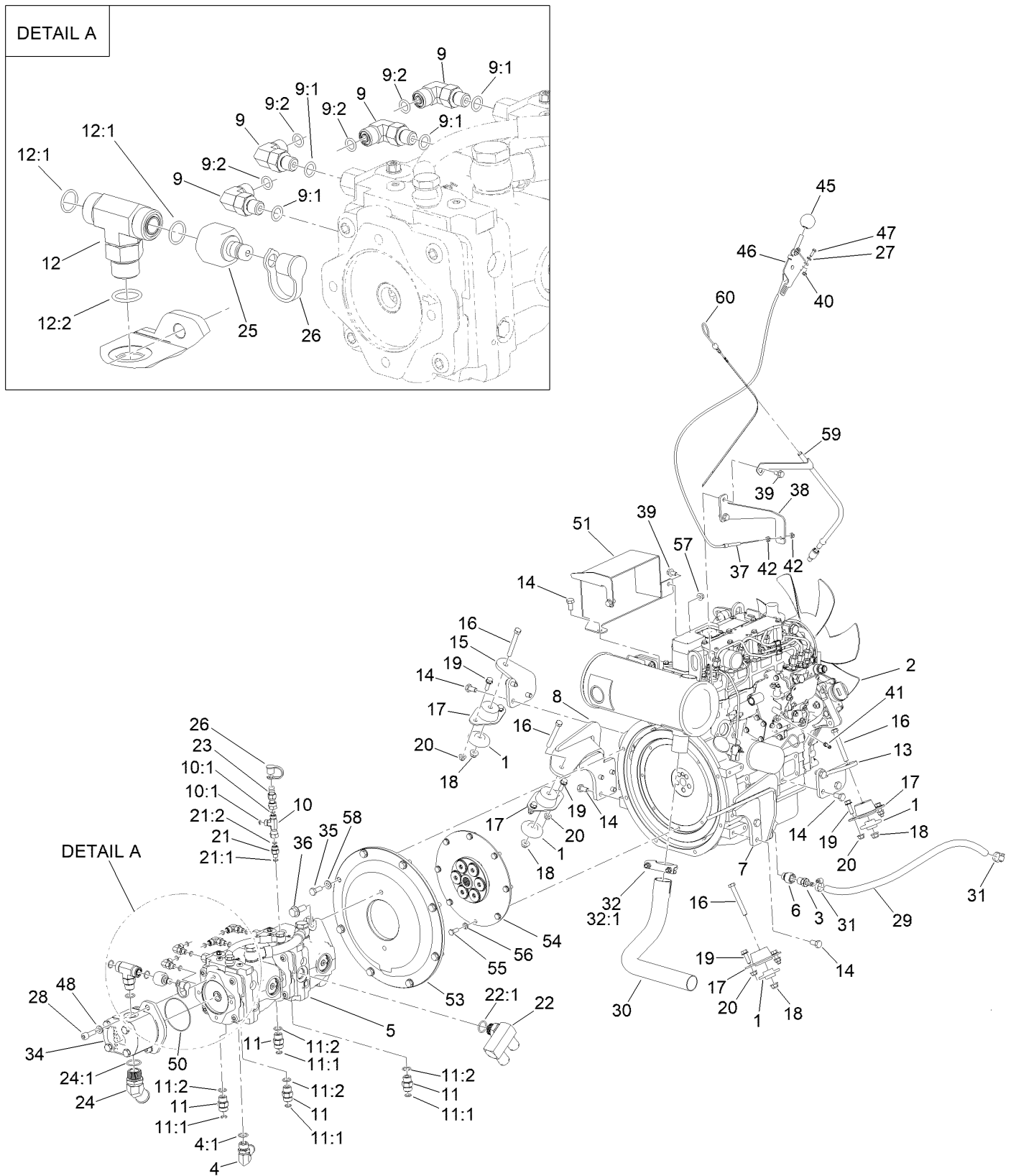

## Engine and Pump Assembly (continued)

<i>Ref.</i>	<i>Part Number</i>	<i>Qty.</i>	<i>Description</i>	<i>Ref.</i>	<i>Part Number</i>	<i>Qty.</i>	<i>Description</i>
1	138-6462	4	Support-Isolator	23	115-8886	1	Nipple-Test
2	145-3262	1	Engine-Yanmar 3Tnv80F-Nxdtr2	24	136-6071	1	Fitting-45 Elbow
3	1-513200	1	Fitting,Male	24:1	237-146	1	O-Ring
4	87-8170	1	Fitting-90	25	86-5860	1	Nipple
4:1	237-80	1	O-Ring	26	354-79	2	Cap-Dust
5	145-3348	1	Pump - Tandem	27	3256-51	2	Washer-Flat
6	139-2218	1	Adaptor-STR	28	AU862-10030	2	Screw-HSH
7	145-3341-03	1	Left Hand Mount [black]	29	119-8562	1	Hose-Fuel
8	145-3340-03	1	Right Hand Mount [black]	30	140-5731	1	Pipe-Exhaust
9	340-132	4	Fitting-Elbow, 90 DEG	31	2412-108	2	Clamp-Worm
9:1	237-78	1	O-Ring	32	2112-6	1	Clamp-Muffler
9:2	237-21	1	O-Ring	32:1	3218-2	2	Nut-Hex Jam
10	340-151	1	Fitting-Tee	34	140-3048	1	Pump-Hydraulic
10:1	237-21	2	O-Ring	35	33115-025	8	Screw-HH
11	340-4	4	Fitting-Straight	36	147-6874	2	Screw-HF
11:1	237-30	1	O-Ring	37	144-7483	1	Throttle Cable
11:2	237-79	1	O-Ring	38	163-3236	1	Bracket-Throttle Cable
12	340-93	1	Tee-Adapter	39	33104-016	4	Screw-HHF
12:1	237-65	2	O-Ring	40	32149-7	2	Nut-Keps
12:2	237-80	1	O-Ring	41	142-3886	1	Wire-Stop
13	140-2771-03	1	Bracket-Engine Mount, Rear LH	42	3220-1	2	Nut-Jam
14	33115-020	15	Screw-HH	45	233-42	1	Knob
15	140-2772-03	1	Bracket-Engine Mount, Rear RH	46	108-9730	1	Lever-Control
16	323-14	4	Screw-HH	47	3290-134	2	Screw
17	120-6274	4	Mount-Engine	48	107-1413	2	Washer-Hardened
18	104-8301	4	Nut-HF, NI	50	353-949	1	O-Ring
19	3234-29	8	Screw-HHF	51	145-3176-03	1	Shield-Exhaust [black]
20	104-8300	8	Nut-HF, NI	53	145-3210-0P	1	Cover-Flywheel
21	340-92	1	Fitting-Straight	54	126-6531	1	Coupler-Flywheel
21:1	237-78	1	O-Ring	55	33114-020	8	Screw-HH
21:2	237-21	1	O-Ring	56	3253-4	8	Washer-Lock
22	145-0621	1	Fitting	57	33004-00	1	Nut-HF
22:1	237-81	1	O-Ring	58	33095-00	8	Washer-Flat
				59	163-5320	1	Dipstick
				60	163-1158	1	Dipstick, Lub.Oil

# Hydraulic Pump Assembly No. 140-3048

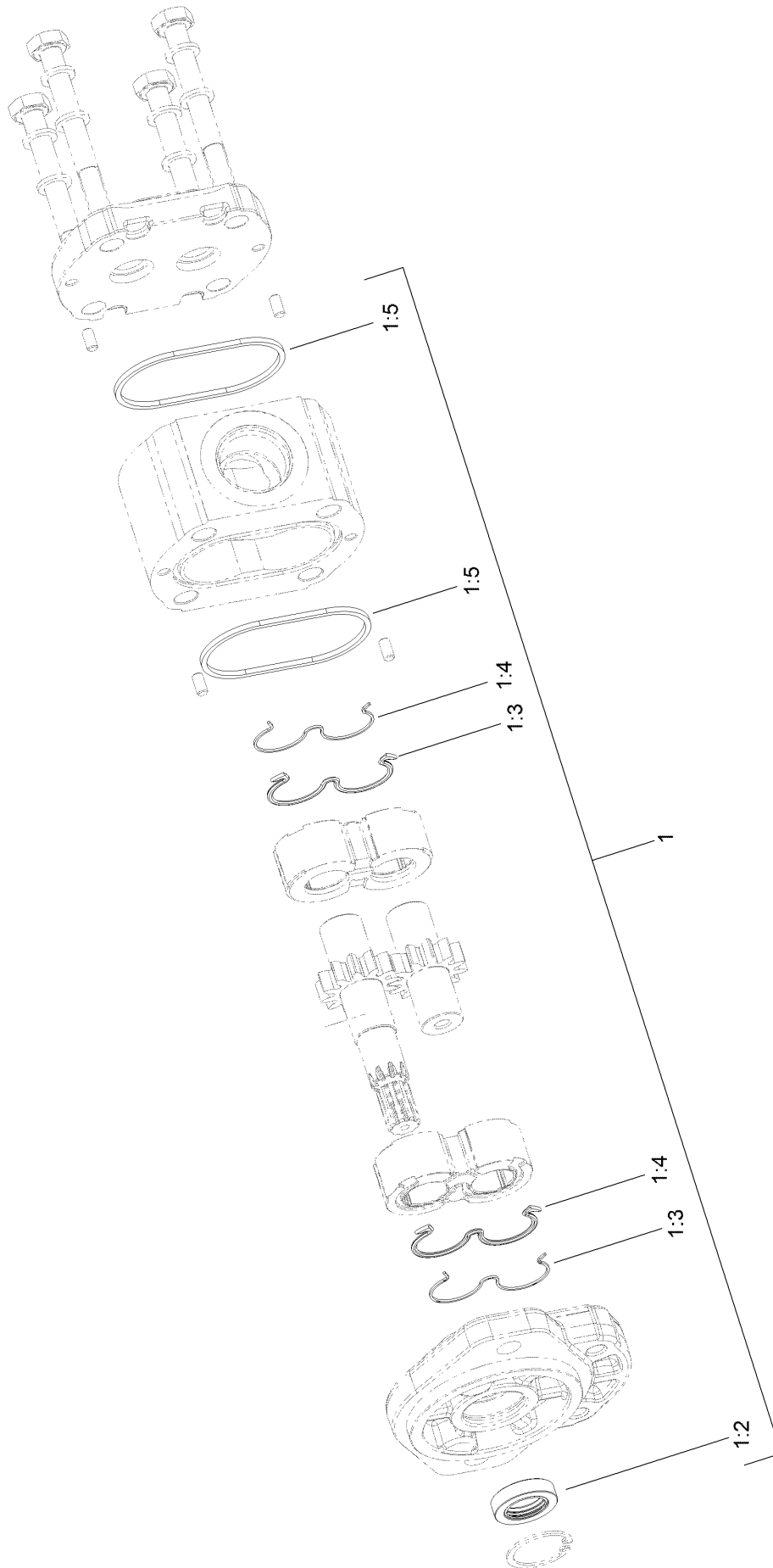

# Hydraulic Pump Assembly No. 140-3048 (continued)

<i>Ref.</i>	<i>Part Number</i>	<i>Qty.</i>	<i>Description</i>
1	119-7135	1	Kit-Seal
1:2		1	Shaft Seal ●
1:3		2	Anti-Extrusion Seal ●

<i>Ref.</i>	<i>Part Number</i>	<i>Qty.</i>	<i>Description</i>
1:4		2	Seal ●
1:5		2	Seal Square Section ●

● Not serviced separately

# Hydraulic Assembly

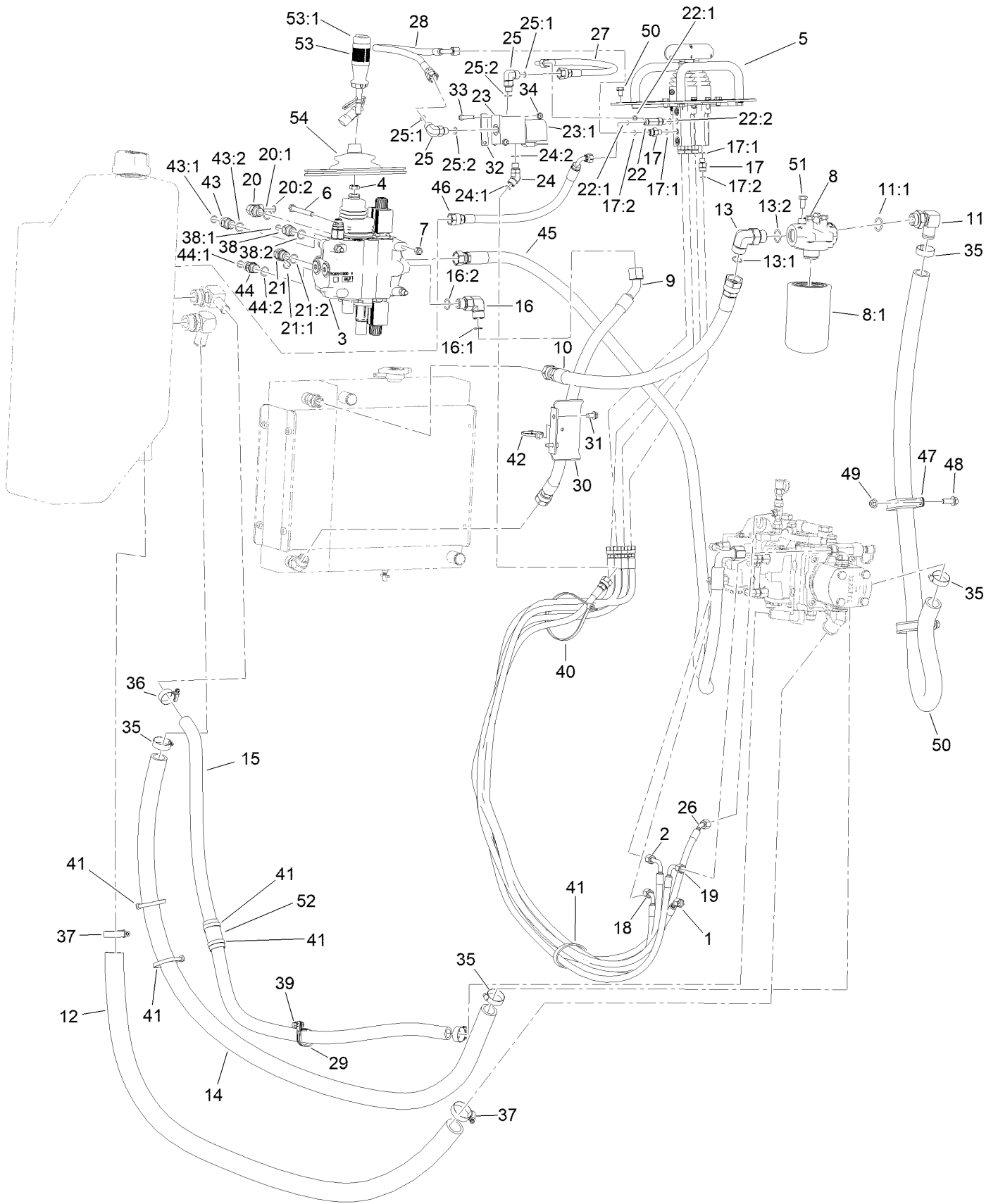

## Hydraulic Assembly (continued)

<i>Ref.</i>	<i>Part Number</i>	<i>Qty.</i>	<i>Description</i>	<i>Ref.</i>	<i>Part Number</i>	<i>Qty.</i>	<i>Description</i>
1	140-3016	1	Hose ASM-HYD	24:2	237-42	1	O-Ring
2	140-3017	1	Hose ASM-HYD	25	340-77	2	Fitting-Elbow, 90 DEG
3	161-9440	1	Loader Valve ASM	25:1	237-22	1	O-Ring
4	51-2070	1	Nut	25:2	237-42	1	O-Ring
5	140-2940	1	Traction Control ASM	26	140-3020	1	Hose ASM-HYD
6	323-15	3	Screw-HH	27	140-3021	1	Hose ASM-HYD
7	3296-39	3	Nut-Lock, NI	28	140-3019	1	Hose ASM-HYD
8	93-2242	1	Oil Filter ASM	29	119-9037	1	Clamp-R
8:1	75-1310	1	Filter-HYD	30	161-2399-03	1	Plate-Hose
9	140-3012	1	Hose ASM-HYD	31	32144-70	2	Screw-HWHTF
10	161-6852	1	Hose ASM-HYD	32	145-3260	1	Plate, Backing
11	100-4202	1	Fitting-90	33	321-18	2	Screw-HH
11:1	237-81	1	O-Ring	34	104-7201	3	Nut-HF, NI
12	140-3023	1	Hose-Return	35	2412-34	4	Clamp-Hose
13	340-142	1	Fitting-Elbow, 90 DEG	36	2412-129	2	Clamp-Hose
13:1	237-58	1	O-Ring	37	2412-111	2	Clamp-Hose, W/Liner
13:2	237-81	1	O-Ring	38	340-3	2	Fitting-Straight
14	140-3025	1	Hose-Return	38:1	237-22	1	O-Ring
15	140-3026	1	Hose-Return	38:2	237-79	1	O-Ring
16	340-17	2	Fitting-Elbow, 90 DEG	39	3234-4	1	Screw-HHF
16:1	237-65	1	O-Ring	40	32180-118	1	Clip-Tie
16:2	237-80	1	O-Ring	41	3334-945	5	Tie-Cable
17	340-92	5	Fitting-Straight	42	32180-030	1	Clip-Tie
17:1	237-78	1	O-Ring	43	340-4	1	Fitting-Straight
17:2	237-21	1	O-Ring	43:1	237-30	1	O-Ring
18	140-3015	1	Hose ASM-HYD	43:2	237-79	1	O-Ring
19	140-3018	1	Hose ASM-HYD	44	163-5286	1	Valve-Check
20	340-98	1	Fitting-Elbow, 90 DEG	44:1	237-79	1	O-Ring
20:1	237-79	1	O-Ring	44:2	237-30	1	O-Ring
20:2	237-30	1	O-Ring	45	140-3014	1	Hose-HYD ASM
21	340-101	1	Fitting-HYD, 45 DEG	46	145-3293	1	Hose ASM-HYD
21:1	237-30	1	O-Ring	47	127-0516	2	Clamp-R, Double
21:2	237-79	1	O-Ring	48	3234-42	2	Screw-HHF
22	340-140	1	Fitting-Tee	49	104-8301	2	Nut-HF, NI
22:1	237-21	2	O-Ring	50	145-3295	1	Hose-Return
22:2	237-78	1	O-Ring	51	33115-020	4	Screw-HH
23	158-627	1	Solenoid Valve	52	AU112950	1	Protector-Hose
23:1	217-770	1	Solenoid Coil	53	140-5742	1	Handle-Auxiliary ASM
24	340-87	1	Fitting-Elbow, 45 DEG	53:1	147-6873	1	Boot-Switch, Joystick
24:1	237-22	1	O-Ring	54	163-3207	1	Boot

# Traction Control Assembly No. 140-2940

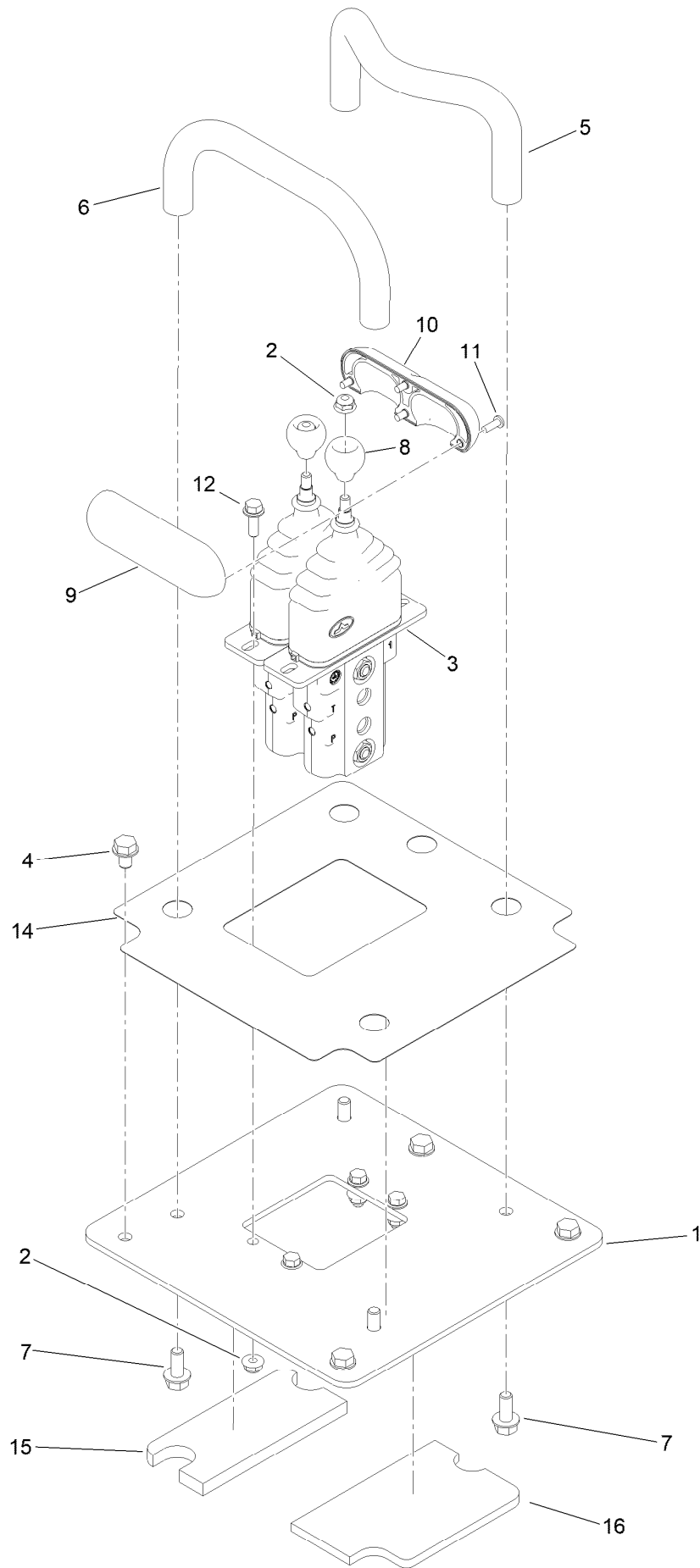

# Traction Control Assembly No. 140-2940 (continued)

<i>Ref.</i>	<i>Part Number</i>	<i>Qty.</i>	<i>Description</i>	<i>Ref.</i>	<i>Part Number</i>	<i>Qty.</i>	<i>Description</i>
1	140-5749-01	1	Panel-Cover	9	130-7692	1	Handle-Control
2	104-7201	6	Nut-HF, NI	10	131-9162	1	Handle-Traction
3	145-3279	1	Valve-Control (Traction)	11	94-6961	4	Screw
4	700057	4	Screw-HWH	12	115-5103	4	Screw-HHF
5	138-0791	1	Bar-Reference	14	145-3242	1	Decal-Traction
6	145-4400	1	Bar-Reference	15	132-8415	1	Foam-Shield, Heat
7	3234-5	4	Screw-HHF	16	145-3241	1	Foam-Shield, Heat
8	130-7723	2	Ball-Traction				

# Control Valve Assembly No. 145-3279

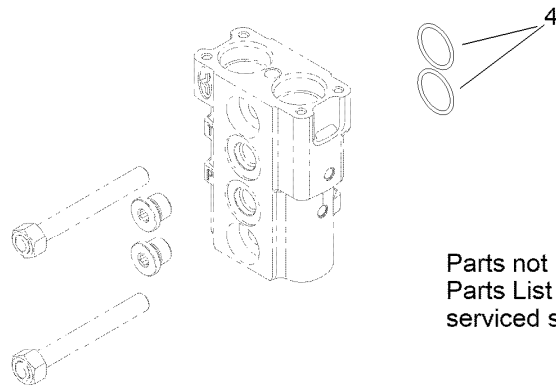
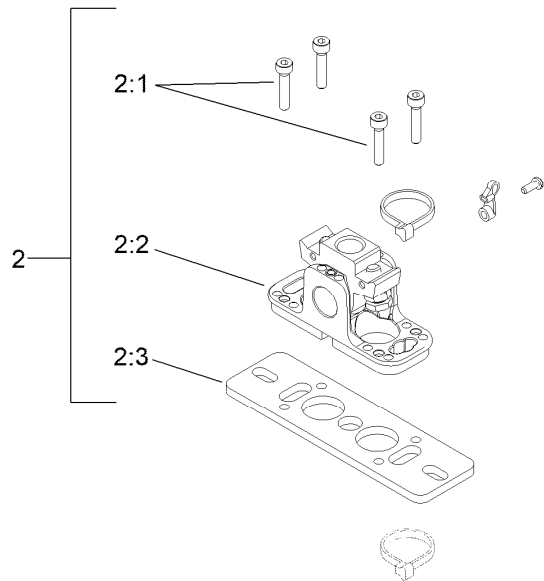
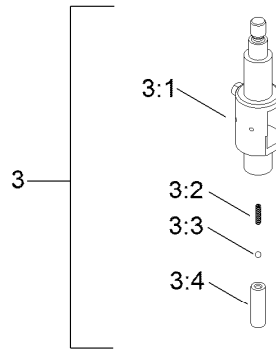
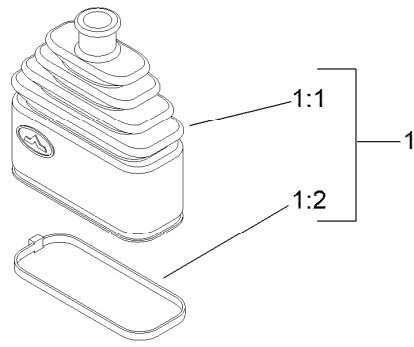

Parts not listed in  
Parts List are not  
serviced separately

# Control Valve Assembly No. 145-3279 (continued)

<i>Ref.</i>	<i>Part Number</i>	<i>Qty.</i>	<i>Description</i>	<i>Ref.</i>	<i>Part Number</i>	<i>Qty.</i>	<i>Description</i>
1	132-6034	2	Bellow Kit	3	132-6037	2	Switch Holder Lever Kit
1:1		1	Bellow-Rubber ●	3:1		1	Lever-Holder, Switch ●
1:2		1	Tie-Cable ●	3:2		1	Spring-Return ●
2	132-6036	2	Fulcrum Kit	3:3		1	Sphere ●
2:1		4	Screw ●	3:4		1	Holder-Spring ●
2:2		1	Support Kit ●	4	100-7246	2	O-Ring
2:3		1	Plate-Mounting ●				

● Not serviced separately

# Loader Arm Assembly

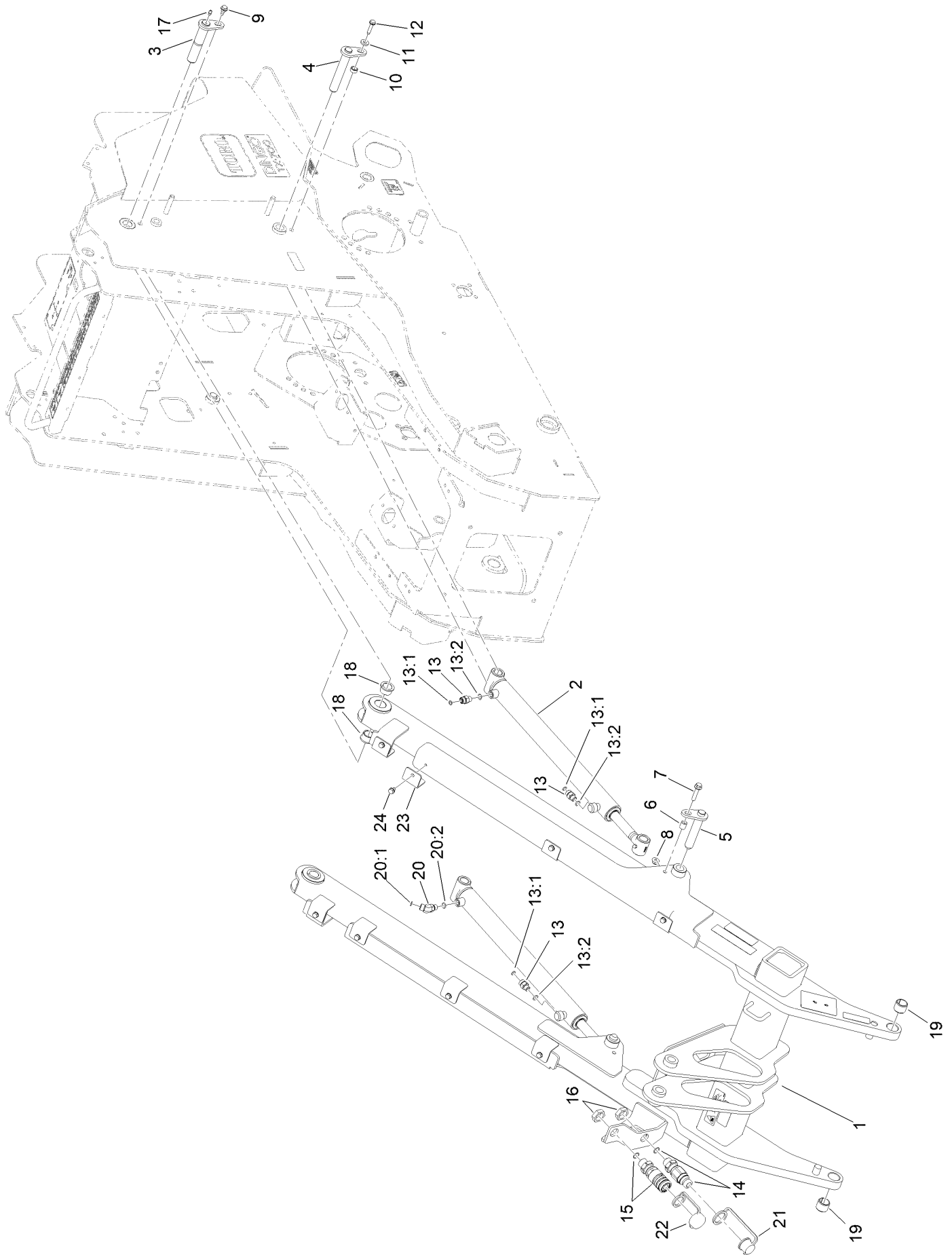

## Loader Arm Assembly (continued)

<i>Ref.</i>	<i>Part Number</i>	<i>Qty.</i>	<i>Description</i>	<i>Ref.</i>	<i>Part Number</i>	<i>Qty.</i>	<i>Description</i>
1	145-3225	1	Loader Arm ASM	13:2	237-42	1	O-Ring
2	140-2974	2	Cly-HYD	14	139-4799	1	Coupler ASM,Bulkhead,
3	139-7270	2	Pin-Flag	15	139-4798	1	Coupler ASM,Bulkhead,
4	140-2927	2	Pivot Pin ASM (Welded)	16	340-74	2	Nut-Lock, Bulkhead
5	140-2925	2	Pivot Pin ASM (Welded)	17	302-5	2	Fitting-Grease
6	136-1462	2	Spacer	18	112-1626	4	Bushing-Flange
7	3234-19	2	Screw-HHF	19	98-4871	2	Bushing-Tension
8	104-8301	2	Nut-HF, NI	20	340-87	1	Fitting-Elbow, 45 DEG
9	99-5105	2	Screw-Shoulder	20:1	237-22	1	O-Ring
10	99-4201	2	Tube-Spacer	20:2	237-42	1	O-Ring
11	71-9310	2	Spacer	21	100-8815	1	Cap-Dust, Nipple
12	32144-57	2	Screw	22	100-8816	1	Cap-Dust, Coupler
13	340-2	3	Fitting-Straight	23	145-3304	8	Plate-Retainer, Hose
13:1	237-22	1	O-Ring	24	700057	8	Screw-HWH

# Loader Arm Assembly No. 145-3225

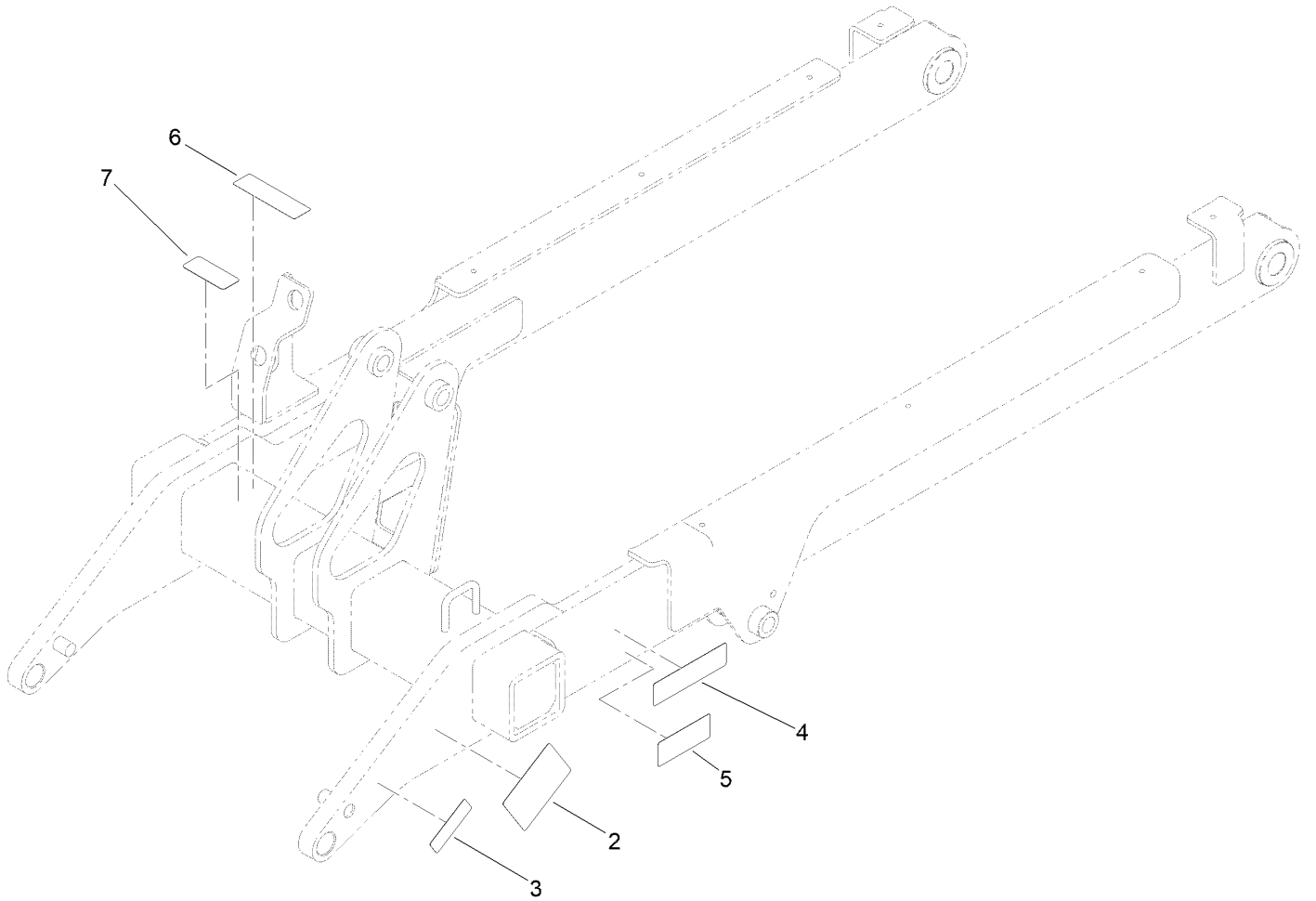

## Loader Arm Assembly No. 145-3225 (continued)

<i>Ref.</i>	<i>Part Number</i>	<i>Qty.</i>	<i>Description</i>	<i>Ref.</i>	<i>Part Number</i>	<i>Qty.</i>	<i>Description</i>
2	145-3252	2	Decal - Warning, Bucket	5	139-1159	2	Decal-Warning
3	120-0625	2	Decal-Warning	6	115-4855	1	Decal-Caution
4	139-1158	2	Decal-Warning	7	139-1173	1	Decal-Warning

# Hydraulic Cylinder Assembly No. 140-2974

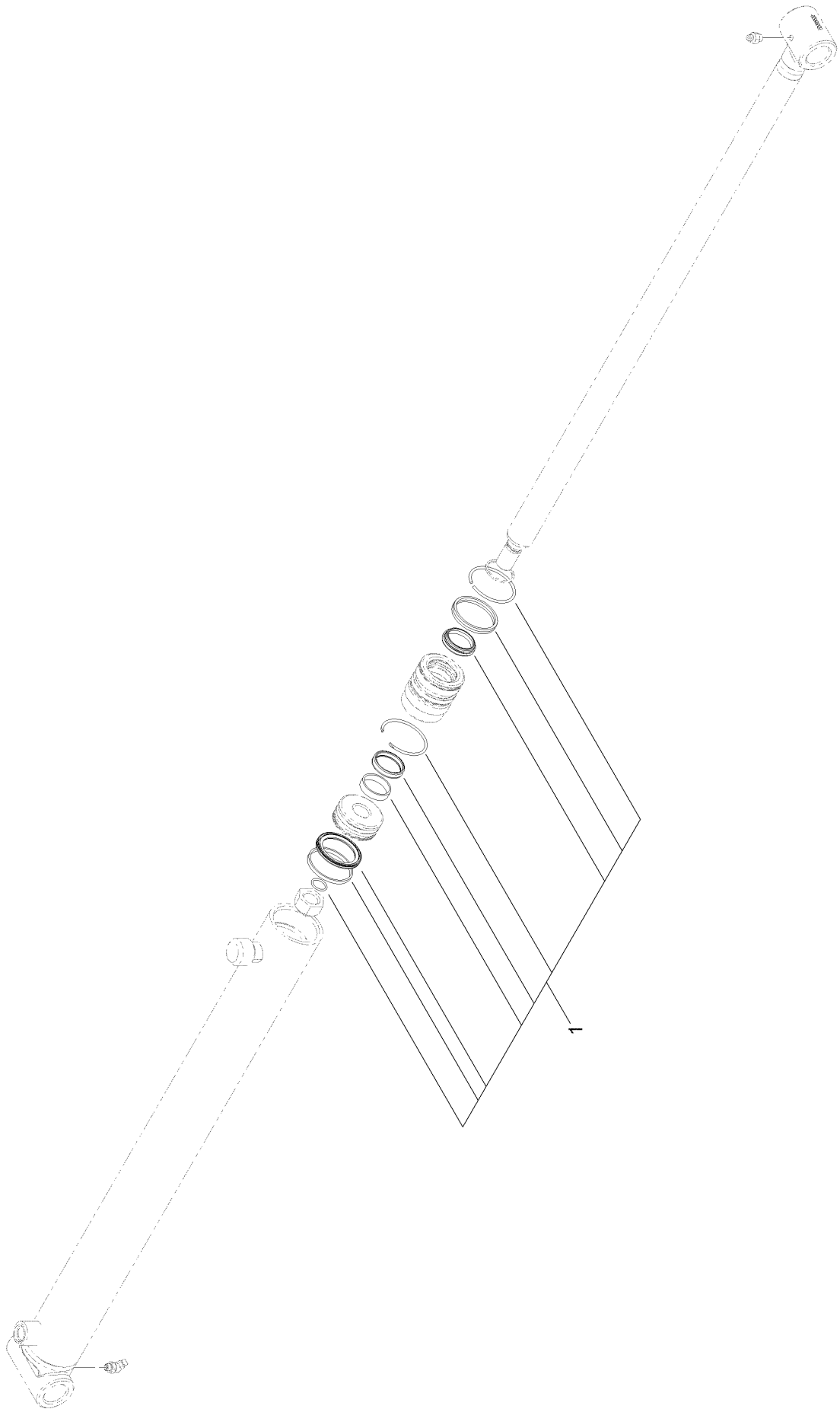

# Hydraulic Cylinder Assembly No. 140-2974 (continued)

<i>Ref.</i>	<i>Part Number</i>	<i>Qty.</i>	<i>Description</i>
1	144-7487	1	Kit-Seal, Hydraulic CYL



## Loader Arm Hydraulic Assembly (continued)

<i>Ref.</i>	<i>Part Number</i>	<i>Qty.</i>	<i>Description</i>	<i>Ref.</i>	<i>Part Number</i>	<i>Qty.</i>	<i>Description</i>
1	140-3008	2	Hose ASM-HYD	6	140-3007	2	Hydraulic Tube ASM
2	140-5732	2	Hose ASM-HYD	6:1	237-22	2	O-Ring
3	140-3010	1	Hose ASM-HYD	7	340-70	2	Nut-Lock
4	140-3011	1	Hose ASM-HYD	8	3334-945	2	Tie-Cable
5	140-2892	1	Hose ASM-HYD	9	145-3329	1	Hose ASM-HYD

# Quick Attach Assembly

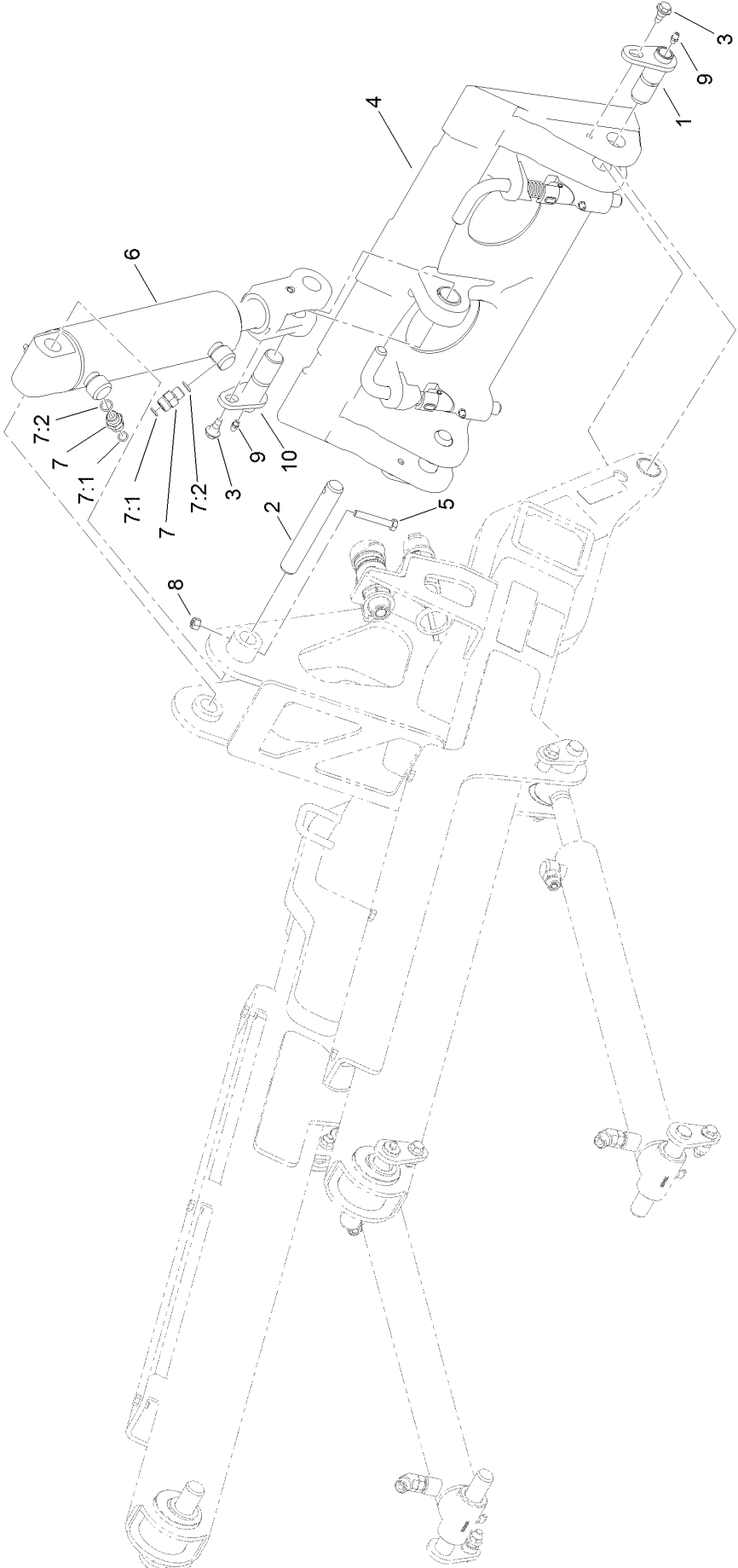

## Quick Attach Assembly (continued)

<i>Ref.</i>	<i>Part Number</i>	<i>Qty.</i>	<i>Description</i>	<i>Ref.</i>	<i>Part Number</i>	<i>Qty.</i>	<i>Description</i>
1	130-5222	2	Pin-Pivot	7	340-2	2	Fitting-Straight
2	104-2849	1	Pin-Locking	7:1	237-22	1	O-Ring
3	99-5105	3	Screw-Shoulder	7:2	237-42	1	O-Ring
4	132-8418	1	Quick Attach ASM	8	3296-29	1	Nut-Lock, NI
5	322-10	1	Screw-HH	9	302-5	3	Fitting-Grease
6	145-3202	1	HYD CYL ASM	10	145-3203	1	Pivot Pin ASM

# Quick Attach Assembly No. 132-8418

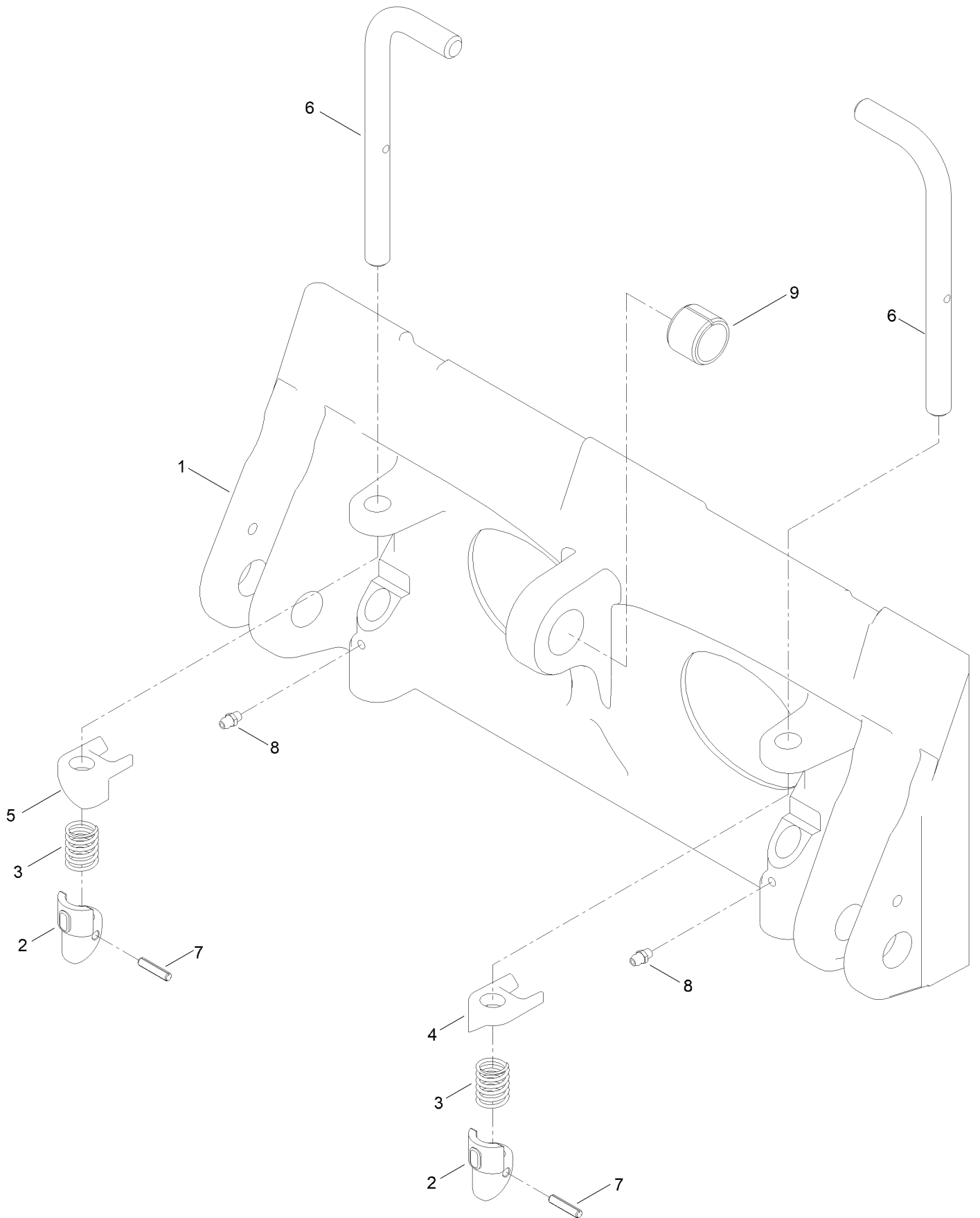

## Quick Attach Assembly No. 132-8418 (continued)

<i>Ref.</i>	<i>Part Number</i>	<i>Qty.</i>	<i>Description</i>	<i>Ref.</i>	<i>Part Number</i>	<i>Qty.</i>	<i>Description</i>
1	130-7708-05	1	Mount-Qtach, [blk-Txt]	6	132-8419	2	Pin-Locking
2	105-0246	2	Cam	7	3285-1	2	Pin-Grooved
3	98-4694	2	Spring-Compression	8	302-5	2	Fitting-Grease
4	104-5909	1	Stop-RH	9	98-4871	1	Bushing-Tension
5	104-5903	1	Stop-LH				

# Hydraulic Cylinder Assembly No. 145-3202

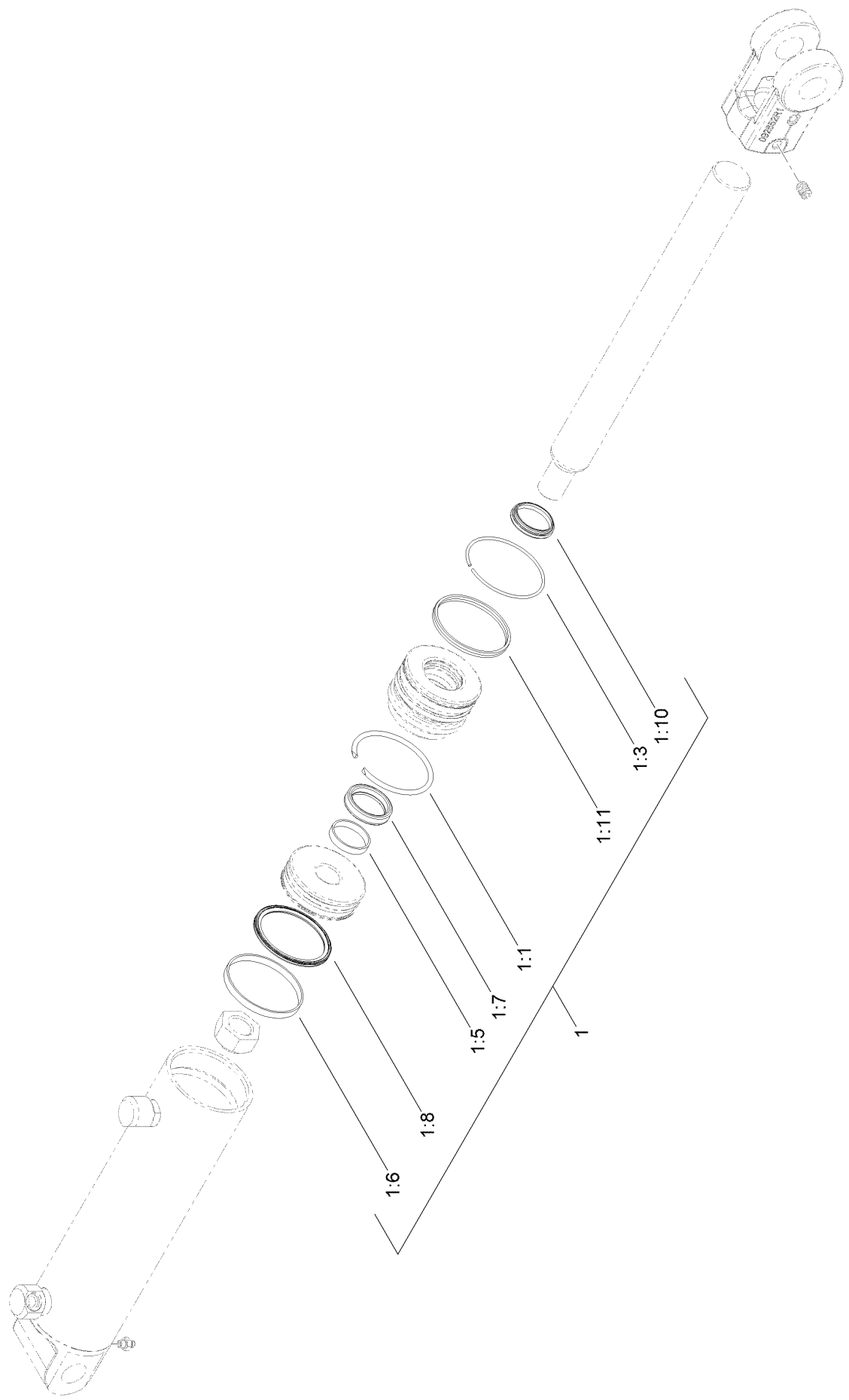

# Hydraulic Cylinder Assembly No. 145-3202 (continued)

<i>Ref.</i>	<i>Part Number</i>	<i>Qty.</i>	<i>Description</i>	<i>Ref.</i>	<i>Part Number</i>	<i>Qty.</i>	<i>Description</i>
1	145-3227	1	Kit-Seal, Hydraulic CYL	1:8		1	Seal Zurcon Wynseal 2.75"-I ■
1:1		1	Retaining Ring Internal 2.7 ■	1:9		1	Seal Zurcon Glyd Ring P 2.7 ● ■
1:2		2	Retaining Ring Remov Tool 2 ● ■	1:10		1	Seal Wiper 1.38 Snap In Da2 ■
1:3		1	Retaining Ring External 2.7 ■	1:11		2	Seal Dual 2.75 ■
1:4		1	Clamp Gear 2.75" ● ■	1:12		1	Seal Kit Stuff Wire Rng Rep ● ■
1:5		1	Wear Ring 1.50-1.38-0.250 ■	1:13		1	Seal Kit Stuff Tss Seals ● ■
1:6		1	Wear Ring 2.75-2.63-0.250 ■				
1:7		1	Seal Zurcon U-Cup Ru9 1.38 ■				

● Not illustrated

■ Not serviced separately

# Fuel Assembly

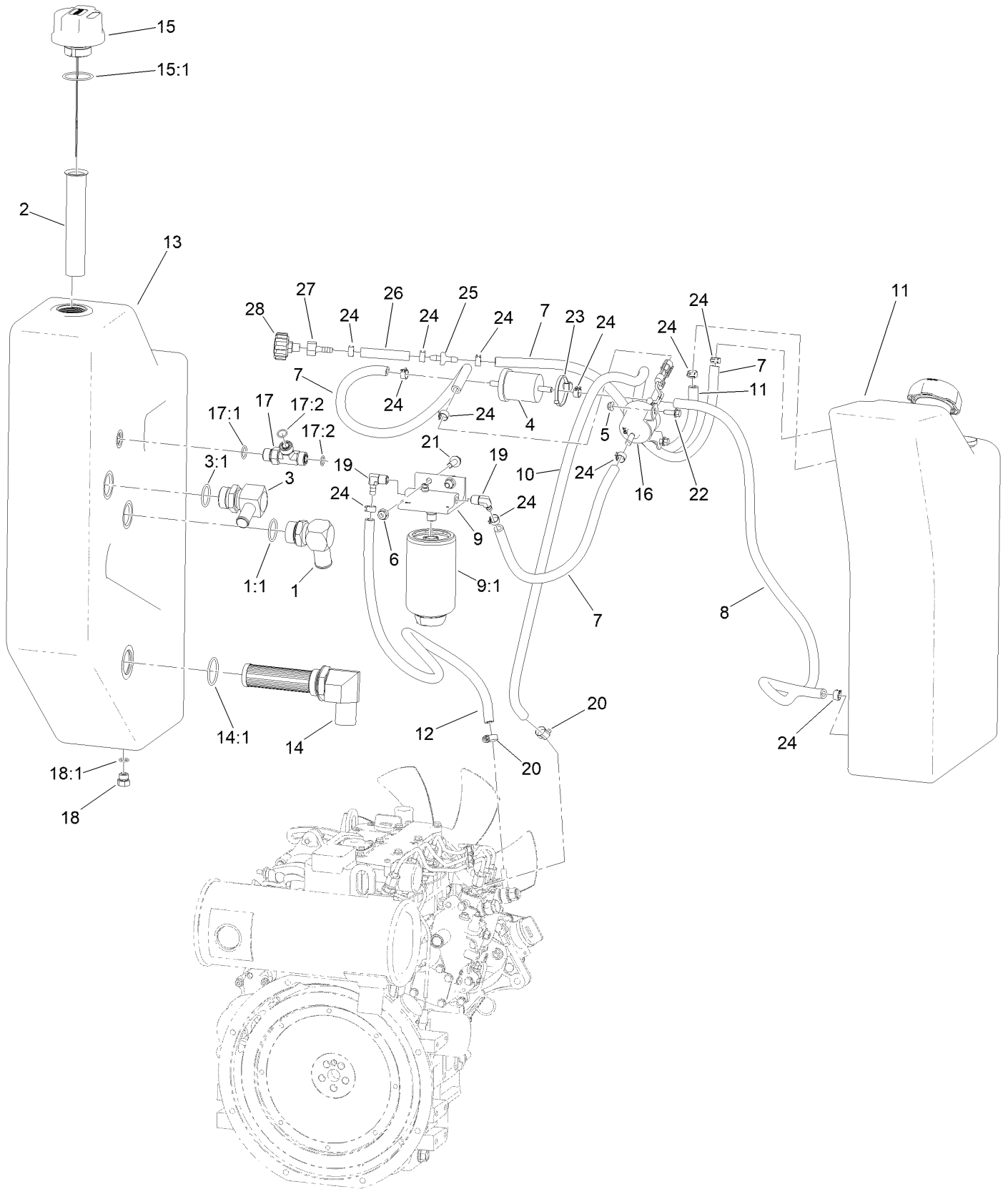

## Fuel Assembly (continued)

<i>Ref.</i>	<i>Part Number</i>	<i>Qty.</i>	<i>Description</i>	<i>Ref.</i>	<i>Part Number</i>	<i>Qty.</i>	<i>Description</i>
1	23-8910	1	Stem-Barb-90	15	145-0642	1	Cap-Filler, Breather
1:1	237-146	1	O-Ring	15:1	237-101	1	O-Ring
2	61-2790	1	Filter-Screen	16	145-3154	1	Pump-Fuel, Electric
3	98-0971	1	Fitting-Elbow, 90	17	340-109	1	Fitting-Tee
3:1	237-117	1	O-Ring	17:1	237-79	1	O-Ring
4	98-7612	1	Filter-Fuel	17:2	237-30	2	O-Ring
5	104-7201	2	Nut-HF, NI	18	353-508	1	Plug-HH
6	104-8300	2	Nut-HF, NI	18:1	237-42	1	O-Ring
7	108-3284	3	Hose-Fuel	19	353-781	2	Fitting-HYD, 90
8	109-0309	1	Hose-Fuel	20	2412-108	2	Clamp-Worm
9	110-9044	1	Separator-Filter	21	3234-17	2	Screw-HHF
9:1	110-9049	1	Filter-Spin On, Fuel/Water	22	3234-4	2	Screw-HHF
10	130-4346	1	Hose-Fuel	23	32180-030	1	Clip-Tie
11	140-5762	1	Tank ASM, LH	24	92-2379	12	Clamp-Hose
12	140-5774	1	Hose-Fuel	25	99-5000	1	Valve-Check, Fuel
13	144-6096	1	Tank-Hydraulic	26	112-6388	1	Hose-Fuel
14	145-0622	1	Strainer Fitting ASM	27	354-95	1	Fitting-Straight
14:1	237-101	1	O-Ring	28	68-6150	1	Breather

# Fuel Tank Assembly No. 140-5762

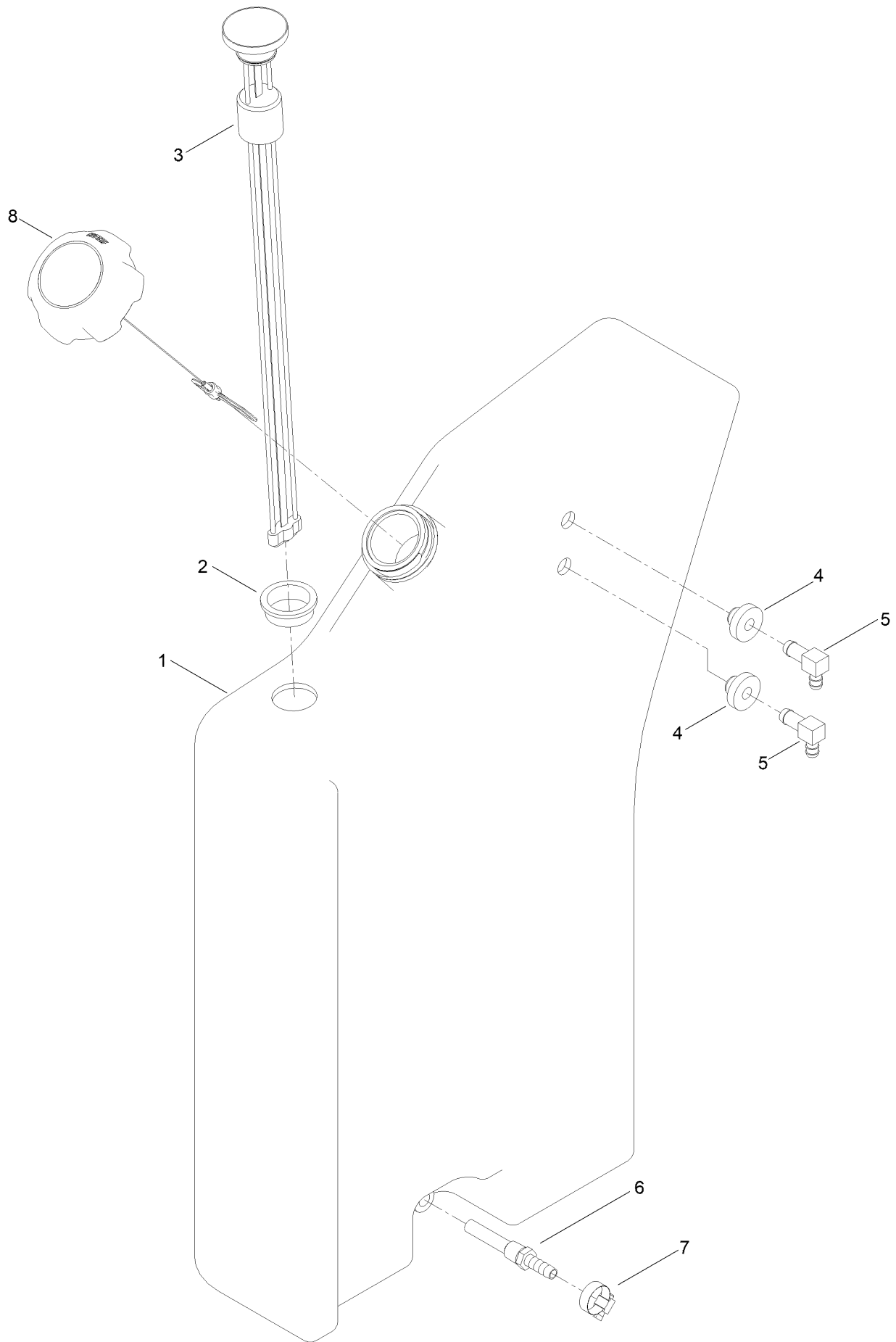

## Fuel Tank Assembly No. 140-5762 (continued)

<i>Ref.</i>	<i>Part Number</i>	<i>Qty.</i>	<i>Description</i>	<i>Ref.</i>	<i>Part Number</i>	<i>Qty.</i>	<i>Description</i>
1	125-3709	1	Fuel Tank ASM	5	46-6550	2	Fitting-Elbow, 90 DEG
2	95-8972	1	Grommet	6	112-6374	1	Fitting-Strainer
3	104-5603	1	Gauge-Level, Fuel	7	2412-36	1	Clamp-Hose
4	46-6560	2	Bushing	8	130-7567	1	Cap-Diesel,



## Hood and Manual Tube Assembly (continued)

<i>Ref.</i>	<i>Part Number</i>	<i>Qty.</i>	<i>Description</i>	<i>Ref.</i>	<i>Part Number</i>	<i>Qty.</i>	<i>Description</i>
1	161-6916	1	ASM-Hood	9	32128-20	2	Nut-HF
1:2	144-4364	1	Latch-Compression, Locking	10	140-2953	1	Hinge-Hood
1:2:1	145-4488	1	Keys-Latch	11	107069	4	Clip
1:3	92-1242	1	Decal	12	161-6909-05	1	Panel-Side, RH
1:4	140-5942	2	Seal-Bulb	13	161-6912-05	1	Panel-Side, LH
2	161-6920-05	1	Mount-Shock	14	163-3225-05	1	Panel, Front
3	2412-120	2	Clamp-R	15	109-4872	2	Screw-HSH
4	104-7050	1	Tube-Manual	16	104-8300	2	Nut-HF, NI
5	104-7048	1	Cap-Housing	17	3274-69	9	Screw-HSBH
6	3269-17	2	Rivet-Pop	18	104-7201	5	Nut-HF, NI
7	3269-10	2	Washer-Back	20	98-3104	2	Stud-Ball
8	137-3060	2	Bolt-CARR	21	147-6766	1	Spring-Gas

# Platform Assembly

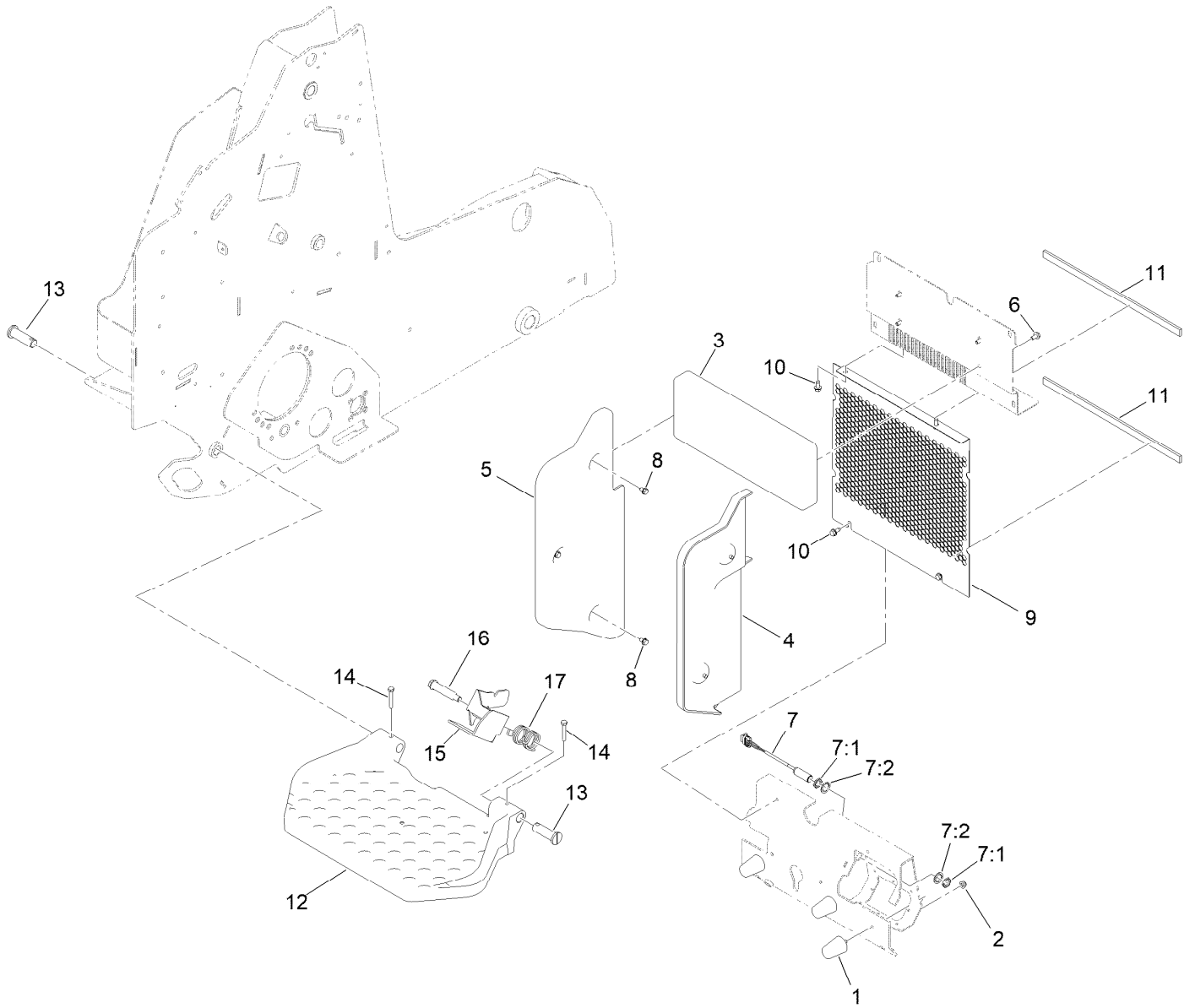

## Platform Assembly (continued)

<i>Ref.</i>	<i>Part Number</i>	<i>Qty.</i>	<i>Description</i>	<i>Ref.</i>	<i>Part Number</i>	<i>Qty.</i>	<i>Description</i>
1	110-5070	3	Bumper	9	140-5781-05	1	Screen-Radiator
2	104-8300	3	Nut-HF, NI	10	32144-70	4	Screw-HWHTF
3	144-6059	1	Cushion-Pad	11	145-3276	2	Pad-Rubber
4	144-2113	1	Cover-Right	12	147-9001-05	1	Operator Platform [blk-Txt]
5	144-2114	1	Cover-Left	13	147-6772	2	Pin-Platform
6	3234-7	4	Screw-HHF	14	322-10	2	Screw-HH
7	115-5300	1	Proximity Switch ASM	15	147-9030-05	1	Pedal-ASM
7:1	117-3207	2	Nut-Hex	16	126-9209	1	Bolt-Shoulder
7:2	117-3208	2	Washer-Lock, Internal Tooth	17	147-6857	1	Spring-Torsion, Twin Coils
8	700057	5	Screw-HWH				

# Electrical Assembly

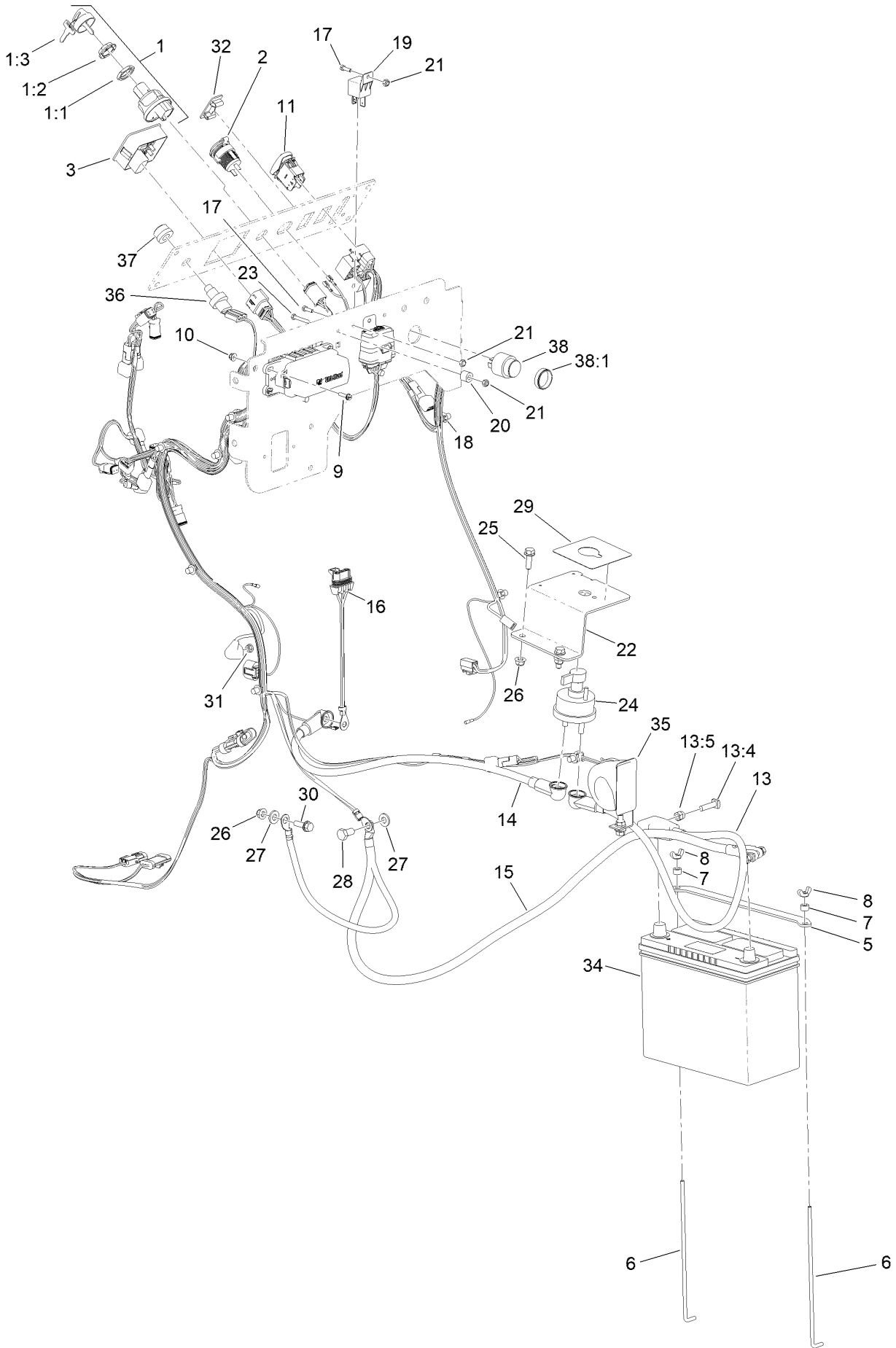

## Electrical Assembly (continued)

<i>Ref.</i>	<i>Part Number</i>	<i>Qty.</i>	<i>Description</i>	<i>Ref.</i>	<i>Part Number</i>	<i>Qty.</i>	<i>Description</i>
1	121-5159	1	Switch-Ignition	20	93-1144	1	Spacer - Fuel Tank
1:1	121-5160	1	Nut-Hex	21	3296-2	3	Nut-Lock, NI
1:2	122-2704	1	Nut-Face, M22 (Plastic)	22	161-6935-05	1	Bracket-Switch
1:3	121-5162	1	Set-Key, Ignition	23	3290-360	1	Screw-HH
2	109-9376	1	Receptacle-12V	24	AUR52278	1	Switch-Disconnect, Master
3	130-7635	1	Module-Hour Meter	24:1	3253-21	2	Washer-Lock ●
5	136-5755-03	1	Strap-Hold Down, Battery	24:2	126-0687	2	Nut-Hex ●
6	136-5756	2	Rod-Hold Down, Battery	24:3	515-0040	1	Washer,Lock,Int,.91X1.387X.056,Stl, ●
7	98-4799	2	Spacer	25	3234-17	3	Screw-HHF
8	1-803038	2	Wingnut	26	104-8300	4	Nut-HF, NI
9	32105-13	4	Screw-HWH	27	100-4852	2	Washer-Hardened
10	120-4578	4	Nut-HF	28	33115-020	1	Screw-HH
11	122-3953	1	Switch-Rocker, (On)-Off-(On)	29	131-8026	1	Decal-Battery Disconnect
13	122-2825	1	Cable-Battery, Rd ASM	30	3234-29	1	Screw-HHF
13:4	32180-109	1	Bolt-Battery Clamp, 5/16-18 Unc	31	33003-00	1	Nut-HF
13:5	32180-108	1	Nut-Hex Shoulder	32	99-7420	1	Plug-Hole
14	122-2826	1	Cable-Battery, Rd ASM	34	145-3278	1	Battery - Corrosive
15	122-2827	1	Cable-Battery, Bk ASM	35	116749	1	Horn
16	99-3441	1	Harness-Wire, Fusible Link	36	112-3324	1	Switch-Horn
17	3290-134	2	Screw	37	112-3313	1	Nut-Weatherproof
18	122-3946	1	Harness-Wire, Main	38	80-9330	1	Audio Alarm ASM
19	99-7435	3	Relay	38:1	104-5107	1	Nut-Plastic, Knurled

● Not illustrated

# Main Wire Harness Assembly No. 122-3946

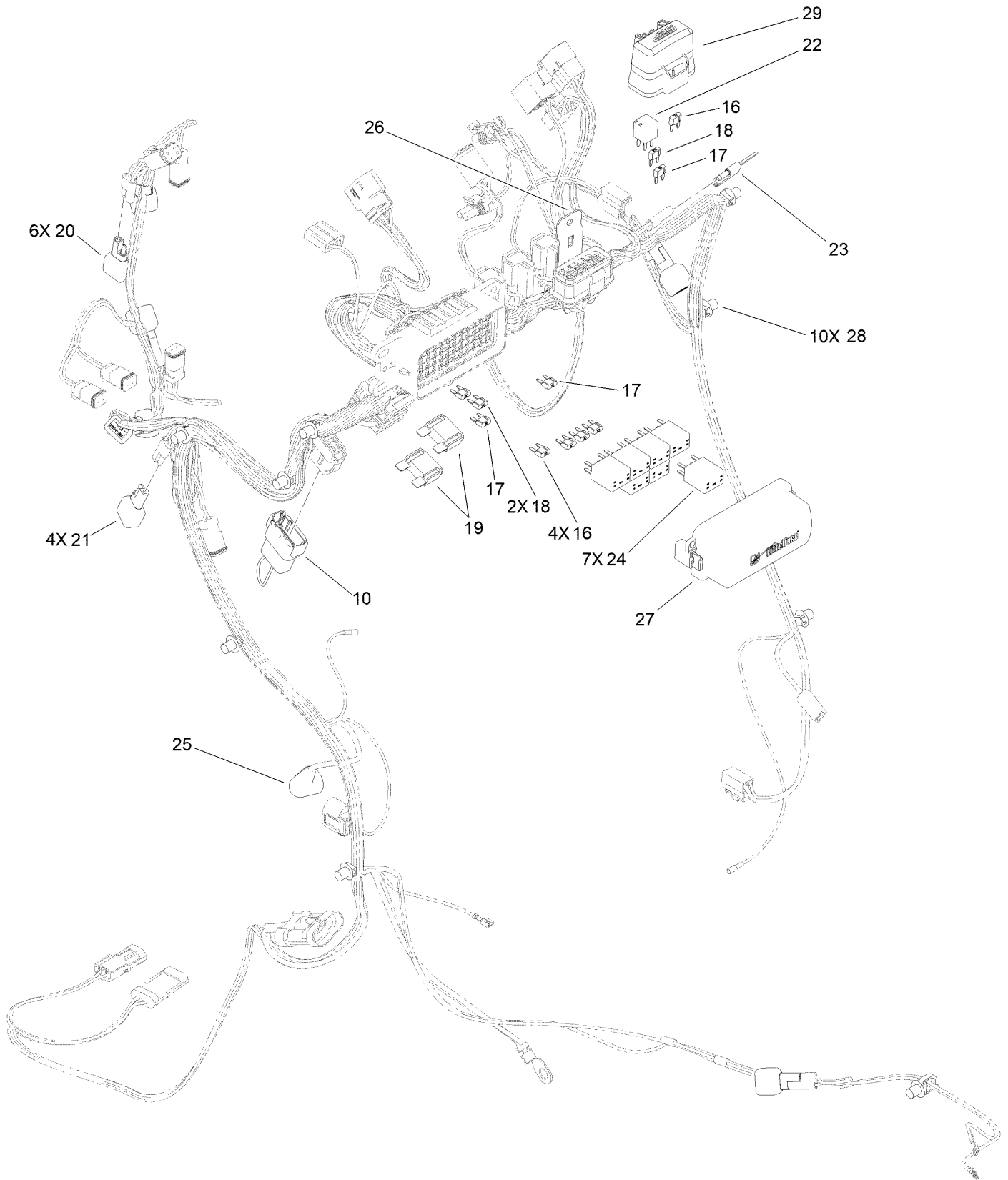

# Main Wire Harness Assembly No. 122-3946 (continued)

<i>Ref.</i>	<i>Part Number</i>	<i>Qty.</i>	<i>Description</i>	<i>Ref.</i>	<i>Part Number</i>	<i>Qty.</i>	<i>Description</i>
10	122-3975	1	Harness-Wire, Jumper	23	32180-416	1	Cap-Tethered
16	121-8866	5	Fuse-Mini Blade, 10 Amp	24	122-0368	7	Relay-280 ISO
17	121-8867	3	Fuse-Mini Blade, 15 Amp	25	32180-017	1	Insulater-Terminal, Black
18	121-8868	3	Fuse-Mini Blade, 20 Amp	26	32180-177	1	Clip-Mounting
19	94-8002	2	Fuse-Blade, 50 Amp	27	32180-229	1	Cover-Littelfuse, Pdm 60F
20	100-4918	6	Diode	28	32180-139	10	Mount-Tie Wrap, Magnetic
21	108-9493	4	Diode-Tvs	29	32180-176	1	Cover-Block, Fuse
22	126-3991	1	Relay-Micro	30	32180-156	1	Cap-Plug, 6 Way ●

● Not illustrated

# Attachments and Accessories

## For 22750 TX 700 Narrow Track Compact Tool Carrier

<b>Product Name</b>	<b>Model/Part</b>
Premium Engine Oil 10w30 (55 Gallon Drum) .....	121-6392
Premium Engine Oil 10w30 (5 Gallon Pail) .....	121-6393
Premium Engine Oil 15w40 (55 Gallon Drum) .....	121-6394
Premium Engine Oil 15w40 (5 Gallon Pail) .....	121-6395
PX Hydraulic Fluid (5 Gal) .....	133-8086
PX Hydraulic Fluid (55 Gal).....	133-8087
PX Hydraulic Fluid-4 Pack (Gallon).....	138-9460
Standard Bucket .....	22340
4 Cubic Foot Standard Bucket .....	22409
Loose Materials Bucket .....	22410
48in Hydraulic Blade .....	22414
Bore Drive Head .....	22420
Rod and Reamer .....	22421
Stump Grinder .....	22429
Tree Forks .....	22438
Cement Bowl .....	22442
40in Tiller .....	22445
Crumber Kit .....	22464
Trench Filler .....	22472
High-Torque Trencher Head .....	22473
High-Speed Trencher Head .....	22474
Crumber Kit .....	22477
4-in-1 Bucket .....	22478
Narrow Bucket .....	22520
Standard Bucket with Spacer.....	22522
Grapple Rake .....	22577
Snow Thrower .....	22585
Grapple Bucket.....	22590
Floor Scraper.....	22673
Auger Head .....	22805
Universal Swivel Auger Head .....	22806
18in Auger Bit .....	22814
24in Auger Bit .....	22815
30in Auger Bit .....	22816
12in Auger Bit Extension .....	22818
24in Auger Bit Extension .....	22819
6in Full-Flight Auger Bit .....	22820
9in Full-Flight Auger Bit .....	22821
12in Full-Flight Auger Bit.....	22822
15in Full-Flight Auger Bit.....	22823
Vibratory Plow .....	22911
Soil Cultivator .....	23102
Leveler.....	23165
30in Standard Bucket .....	23174
30in Pallet Fork.....	23175
30in Grapple .....	23176

# Attachments and Accessories (continued)

New Red Paint - Gallon .....361-11  
Semi-Gloss Black Spray Paint ..... 361-9  
Air Dry Red Paint - Qt ..... 5340



**Count on it.**