



Form No. 3329-751 Rev A

Sonic Boom™ Kit

for Multi Pro® 1200, 1250, and 5600 Turf Sprayers

Model No. 41089—Serial No. 230000001 and Up

Installation Instructions

Important To use this kit, you must also have the electric boom lift kit, available from your Authorized Toro Distributor.

Note: Determine the left, right, front, and rear sides of the machine while seated in the normal operating position.

Note: If you are installing this kit on a vehicle equipped with an enclosed boom system, use these instructions along with the enclosed boom system instructions.

Description	Qty.	Use
Ultrasonic sensor	2	Install the ultrasonic sensors.
U-bolt	4	
Washer, 5/16 inch	8	
Locknut, 1/4 inch	8	
Corrugated tube	2	
Cable ties	8	
Electronic control unit (ECU)	1	Install the ECU.
Mount plate	1	
Relay	4	
Bolt, 1/4 x 5/8 inch	4	
Lock washer, 1/4 inch	8	
Nut, 1/4 inch	8	
Wiring harness	1	
Screw, #10	2	
Nut, #10	2	
Bolt, 1/4 x 2-1/2 inches	4	
Bolt, 5/16 x 3/4 inch	2	
Lock washer, 5/16 inch	2	
Light assembly	1	Install the light.
Decal, 94-8582	1	
Switch	1	Install the controls.
Fuse, 30 amp	1	
Cable ties	8	
Decal, 94-8604	1	Save for diagnostic use by your Authorized Toro Distributor.

Setup

If you do not have the electric boom lift kit installed, install the actuators before installing this kit, but do not install the wiring harness or switches for the electric boom lift kit. If you have already installed the complete electric boom lift kit, disconnect the wiring harness from the actuators and vehicle, and remove and discard it.

Installing the Ultrasonic Sensors

1. Park the sprayer on a flat surface, lower the booms, set the parking brake, stop the engine, and remove the key.
2. Lightly secure the right ultrasonic sensor to the right boom pipe halfway between the last nozzle and the vertical support (Fig. 1), using 2 U-bolts, 4 washers (5/16 inch), and 4 locknuts (1/4 inch).

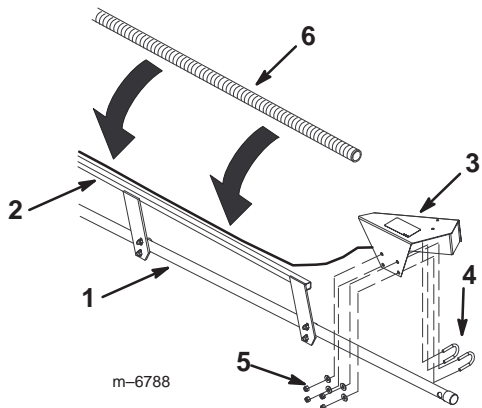

Figure 1

- | | |
|----------------------|---|
| 1. Boom pipe | 5. Washer, 5/16 inch, and locknut, 1/4 inch |
| 2. Boom support | 6. Corrugated tube |
| 3. Ultrasonic sensor | |
| 4. U-bolt | |

3. Rotate the sensor up so that it is approximately 10 degrees off parallel with the ground, then tighten the locknuts on the U-bolts to secure the sensor (Fig. 2)

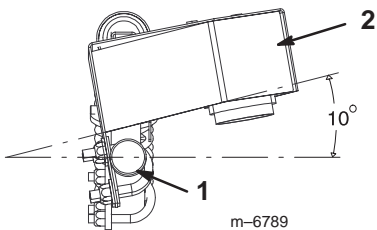

Figure 2

- | | |
|-------------|-----------|
| 1. Boom end | 2. Sensor |
|-------------|-----------|

4. Route the sensor wire along the top of the boom support to the center of the center boom pipe (Fig. 1).

Important Ensure that you leave enough slack in the wire near the joint of the extension boom so that you can raise and lower the boom without pulling on the wire.

5. Place the split, black, corrugated tube over the sensor wire and boom support to cover the wire from the sensor to the end of the boom support (Fig. 1).
6. Use 4 cable ties to secure the tubing to the boom support.
7. Repeat steps 2 through 6 for the left boom extension and left ultrasonic sensor

Installing the Electronic Control Unit (ECU)

1. Secure 4 relays to the mount plate (Fig. 3), using 4 bolts (1/4 x 5/8 inch), 4 lock washers (1/4 inch), and 4 nuts (1/4 inch).

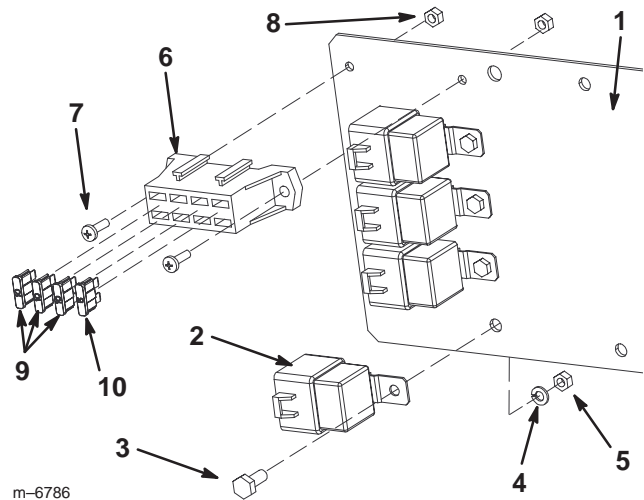

Figure 3

- | | |
|--------------------------|---|
| 1. Mount plate | 6. Fuse block end of the wiring harness |
| 2. Relay | 7. Screw, #10 |
| 3. Bolt, 1/4 x 5/8 inch | 8. Nut, #10 |
| 4. Lock washer, 1/4 inch | 9. Fuse, 10 amp (installed) |
| 5. Nut, 1/4 inch | 10. Fuse, 5 amp (installed) |

2. Secure the fuse block end of the wiring harness to the mounting plate (Fig. 3), using 2 screws (#10) and 2 nuts (#10).

- Secure the ECU to the mount plate (Fig. 4), using 4 bolts (1/4 x 2-1/2 inches), 4 lock washers (1/4 inch), and 4 nuts (1/4 inch).

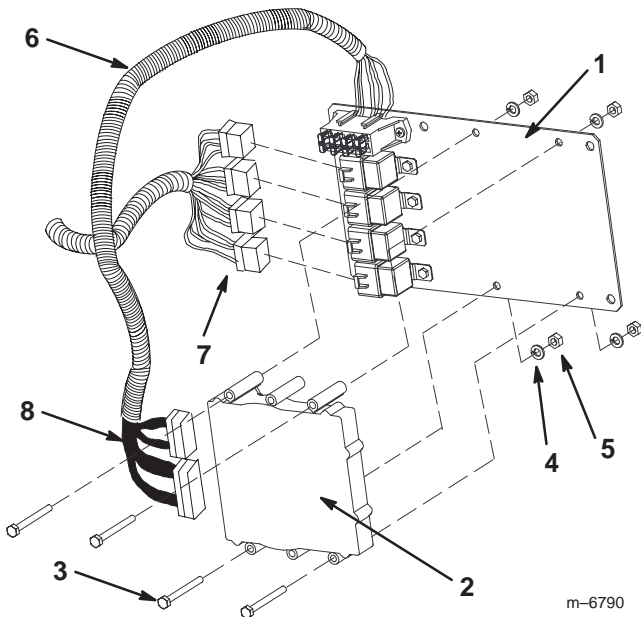

Figure 4

- | | |
|-----------------------------|---------------------|
| 1. Mount plate | 5. Nut, 1/4 inch |
| 2. ECU | 6. Wiring harness |
| 3. Bolt, 1/4 x 2-1/2 inches | 7. Relay leads |
| 4. Lock washer, 1/4 inch | 8. Controller leads |

- Install the mount plate to the vehicle frame under the dash (Fig. 5 for the Multi Pro 1200 and 1250 and Fig. 6 for the Multi Pro 5600), using 2 bolts (5/16 x 3/4 inch) and 2 lock washers (5/16 inch).

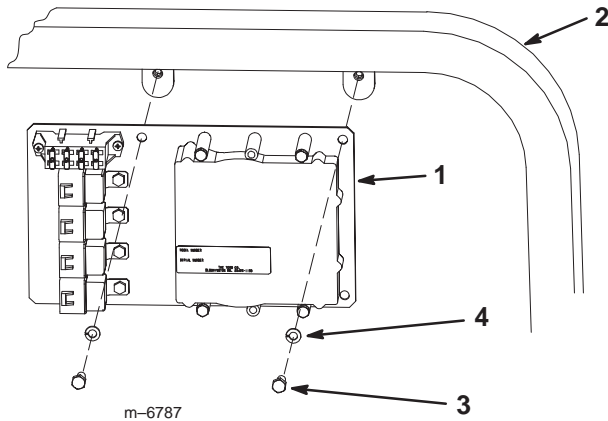

Figure 5

- | | |
|------------------|---------------------------|
| 1. Mount plate | 3. Bolt, 5/16 x 3/4 inch |
| 2. Vehicle frame | 4. Lock washer, 5/16 inch |

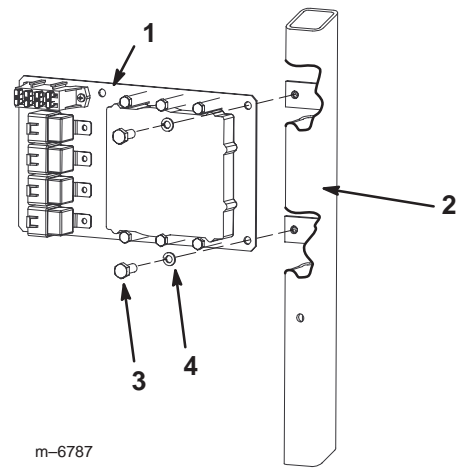

Figure 6

- | | |
|------------------|---------------------------|
| 1. Mount plate | 3. Bolt, 5/16 x 3/4 inch |
| 2. Vehicle frame | 4. Lock washer, 5/16 inch |

- Ensure that the 3, 10-amp fuses and 1, 5-amp fuse are installed in the fuse block on the mount plate as illustrated in Figure 3.
- Connect the relay leads on the wiring harness to the 4 relays on the mounting plate (Fig. 4).
- Connect the 2 controller leads (one long and one short) on the wiring harness to the ECU (Fig. 4).

Installing the Light

- Install decal 94-8582 over the light hole in the dash (Fig. 7 for the Multi Pro 1200 and 1250 and Fig. 8 for the Multi Pro 5600).

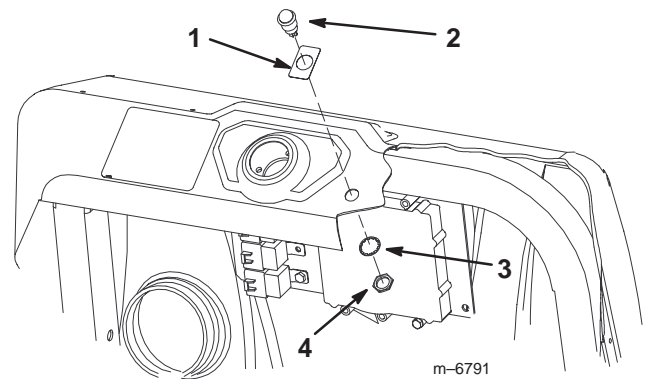

Figure 7

- | | |
|------------------|-----------|
| 1. Decal 94-8582 | 3. Washer |
| 2. Light | 4. Nut |

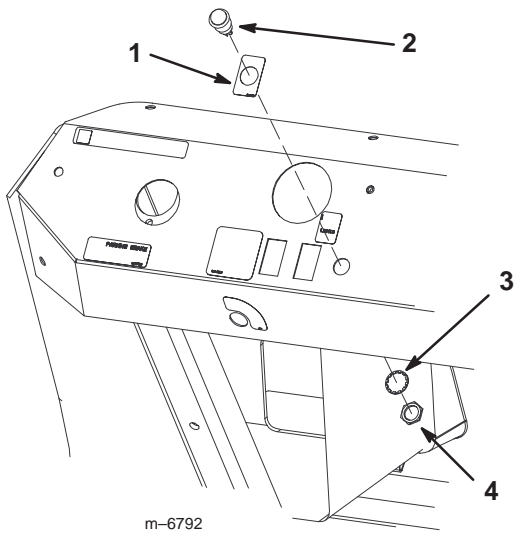

Figure 8

- | | |
|------------------|-----------|
| 1. Decal 94-8582 | 3. Washer |
| 2. Light | 4. Nut |

2. Remove the nut and washer from the bottom of the light.
3. Install the light in the dash and secure it using the washer and nut (Fig. 7 or 8).
4. Connect the 2 spade connectors on a separate branch of the wiring harness to the posts on the light.

Installing the Controls on a Multi Pro 1200 or 1250 Turf Sprayer

Installing the Switches

Note: If you have not already installed the switches from the Electric Boom Lift Kit, install those switches now as described in the instructions with that kit. Do not install the wire harness than comes with that kit.

1. Remove the spray control panel to expose the bottom side (Fig. 9 for the 1250 and Fig. 10 for the 1200).
2. Remove the sonic boom plug from the spray control panel on the vehicle and install the rocker switch provided in its place (Fig. 9 for the 1250 and Fig. 10 for the 1200).

Note: Ensure that the orientation of the switch matches what is shown in Figure 9, with the notch pointing toward the rear of the vehicle.

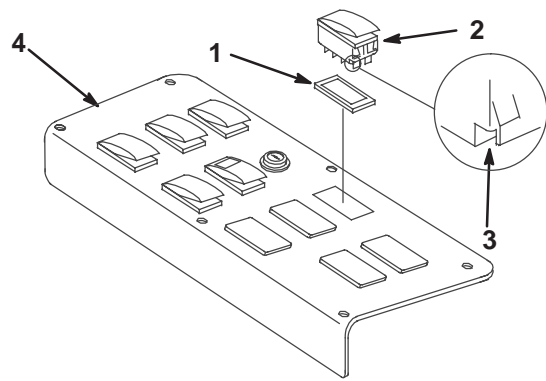

Figure 9

- | | |
|-----------|------------------------|
| 1. Plug | 3. Notch (at back) |
| 2. Switch | 4. Spray control panel |

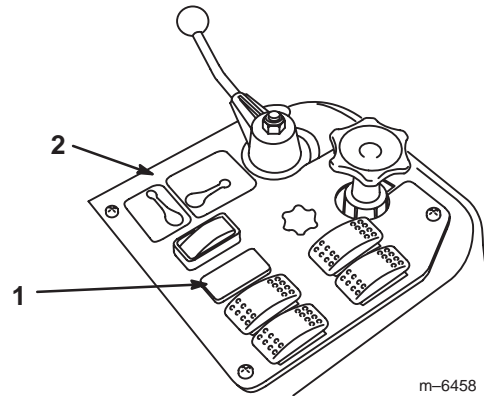

Figure 10

- | | |
|-------------------------------|------------------------|
| 1. Sonic Boom switch location | 2. Spray control panel |
|-------------------------------|------------------------|

Wiring the Switches

1. Route the free end of the wiring harness down through the floor and rearward, through the wire loops to the center boom pipe at the back of the vehicle.
2. Route the branch with the three large connectors into the control panel area.
3. Connect the connector with green, purple, and black wires to the bottom of the right boom lift switch.
4. Connect the connector with light blue, dark blue, and black wires to the bottom of the left boom lift switch.
5. Connect the connector with purple, yellow, and black wires to the bottom of the sonic boom switch.
6. Install the spray control panel.

Connecting the Wiring to the Fuse Block

1. Route the branch of the wiring harness with the small spade connector and a ring or fork terminal into the seat box and to the fuse area.
2. Connect the ring or fork terminal on the black wire to the ground terminal block (Fig. 11).

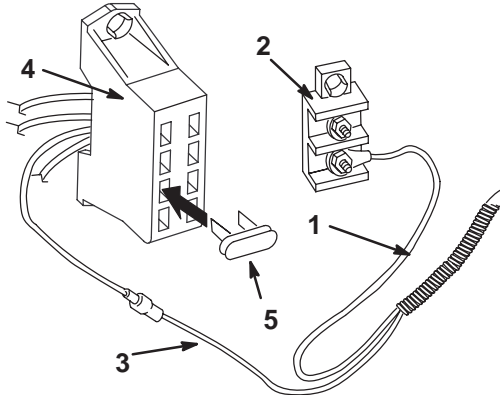

Figure 11

- | | |
|--------------------------|----------------|
| 1. Black wire | 4. Fuse block |
| 2. Ground terminal block | 5. 30-amp fuse |
| 3. Red wire | |

3. Connect the red wire with the spade connector and an open red wire coming from the fuse block.
4. Insert the 30-amp fuse into the fuse block in the position where you connected the red wire (Fig. 11).

Installing the Controls on a Multi Pro 5600 Turf Sprayer

Installing the Switches

Note: If you have not already installed the switches from the Electric Boom Lift Kit, install those switches now as described in the instructions with that kit. Do not install the wire harness than comes with that kit.

1. Remove the spray control panel to expose the bottom side (Fig. 12).

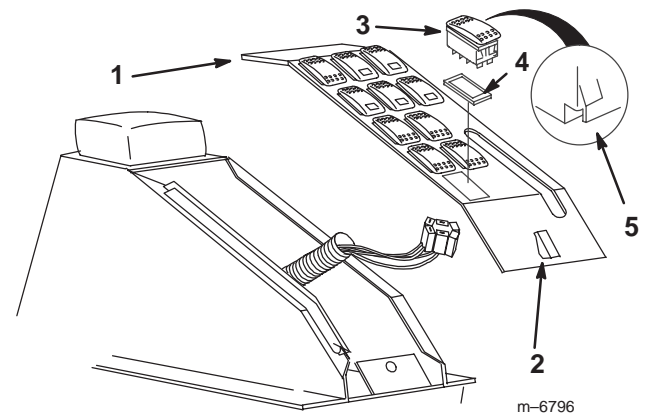

Figure 12

- | | |
|------------------------|----------|
| 1. Spray control panel | 4. Plug |
| 2. Latch | 5. Notch |
| 3. Switch | |

2. Lift and remove the sonic boom plug from the spray control panel on the vehicle and install the rocker switches provided in its place (Fig. 12).

Note: Ensure that the orientation of the switch matches what is shown in Figure 12, with the notch pointing toward the rear of the vehicle.

Wiring the Switches

1. Route the free end of the wiring harness down through the floor and rearward, through the wire loops to the center boom pipe at the back of the vehicle.
2. Route the branch with the three large connectors into the control panel area.
3. Connect the connector with green, purple, and black wires to the bottom of the right boom lift switch.
4. Connect the connector with light blue, dark blue, and black wires to the bottom of the left boom lift switch.
5. Connect the connector with purple, yellow, and black wires to the bottom of the sonic boom switch.
6. Install the spray control panel.

Connecting the Wiring to the Fuse Block

1. Route the branch of the wiring harness with the small spade connector and a ring or fork terminal into the seat box and to the fuse area.
2. Connect the ring or fork terminal on the black wire to the ground terminal block (Fig. 13).

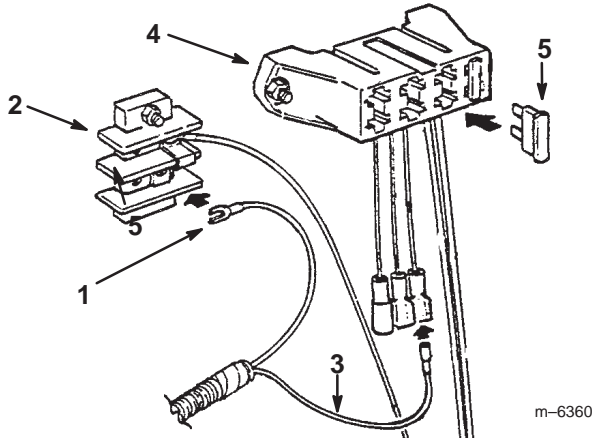

Figure 13

- | | |
|--------------------------|----------------|
| 1. Black wire | 4. Fuse block |
| 2. Ground terminal block | 5. 30-amp fuse |
| 3. Red wire | |

3. Connect the red wire with the spade connector of an open red wire coming from the fuse block.
4. Insert the 30-amp fuse into the fuse block in the position where you connected the red wire (Fig. 13).

Connecting the Wiring to the Sensors and Actuators

1. Ensure that the wire harness is routed to the back of the vehicle along the path of the other wires and hoses.
2. Use cable ties to secure the wiring harness to the other wiring harnesses away from the engine and moving parts.
3. Running the T end of the wiring harness along the center boom frame, connect the wires as follows:
 - A. Connect the connector with the green, purple, and black wires to the connector on the right boom lift actuator.
 - B. Connect the connector with the light blue, dark blue, and black wires to the connector on the left boom lift actuator.
 - C. Connect the connector with the yellow, black/blue, and black wires to the right sensor wire.
 - D. Connect the connector with the yellow, black/orange, and black wires to the left sensor wire.

4. Secure the wiring harness to the boom frame using cable ties as needed.

Calibrating the Sonic Booms

1. Park the sprayer in an open, level turf area that is free of trees, buildings, vehicles, debris, and underground utilities and plumbing.
2. Set the Sonic Boom switch to the manual position.
3. Use the left and right boom switches to move the booms so that they are parallel with the ground.
4. Set the Sonic Boom switch to the Off position.
5. Press and hold a boom switch in either direction and set the Sonic Boom switch to the Automatic position.

The Sonic Boom light flashes rapidly, indicating calibration mode.

6. Release the boom switch.
7. Use the boom switches to adjust the booms if necessary so that they are parallel to the ground.

You have 20 seconds to adjust the booms. At the end of 20 seconds the light stops flashing and the Sonic Boom calibration is complete.

Safety and Instruction Decals



Safety decals and instructions are easily visible to the operator and are located near any area of potential danger. Replace any decal that is damaged or lost.



94-8576



94-8582

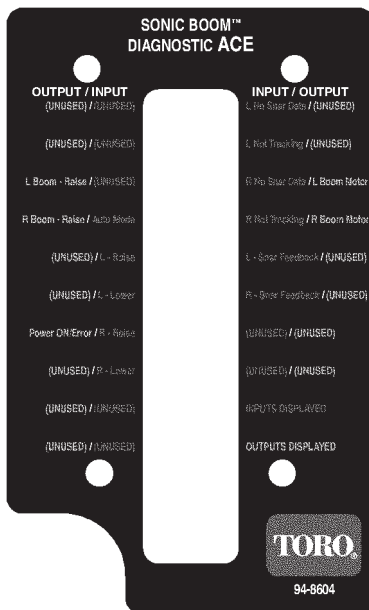

94-8604

Operation

Using the Controls

Sonic Boom switch—this switch has 3 settings: Automatic, Off, and Manual (Fig.), as follows:

- **Automatic**—enables the automatic movement of the booms. When in automatic mode the booms adjust so that the tips of the booms remain the same distance from the ground.

You can temporarily override the automatic operation of the booms using the boom switches to raise or lower one or both booms. If you raise a boom it will remain raised until you lower it halfway with the boom switch; at which point the automatic operation of the boom continues. If you adjust only one boom, the other continues to function automatically.

- **Off**—turns off the automatic adjustment of the booms and disables the boom switches.

- Manual—turns off the automatic adjustment of the booms and enables the boom switches.

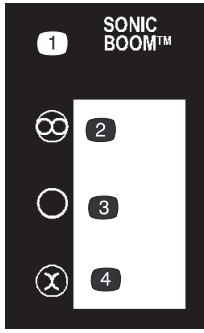

Figure 14

- | | |
|----------------------------|-----------|
| 1. Sonic Boom switch decal | 3. Off |
| 2. Automatic | 4. Manual |

- On—the sonic boom system is on and operating normally
- Flashing quickly—calibration mode
- Flashing slowly—system error; refer to Troubleshooting, page 8.

Maintenance

Clean the sensors periodically with a damp cloth. When you clean the sensors, inspect the foam sensor filter. If it is damaged or excessively dirty, replace it.

Important Do not spray water at or on the sensors. Water sprayed under even household pressure can damage the sensor. Always cover the sensors completely before washing the sprayer.

Sonic Boom light—displays the status of the Sonic Boom system, as follows:

Troubleshooting

Problem	Possible Causes	Corrective Action
One or both booms malfunction; the Sonic Boom light is off.	<ol style="list-style-type: none"> 1. A fuse is blown. 2. The light is burned out. 3. The electronic controller or wiring is damaged. 	<ol style="list-style-type: none"> 1. Replace the fuse. 2. Replace the light. 3. Contact your Authorized Toro Distributor.
One or both booms malfunction; the Sonic Boom light flashes slowly	<ol style="list-style-type: none"> 1. There is a minor system error. 2. There is a system error that repeats after clearing the error. 	<ol style="list-style-type: none"> 1. Lower the affected boom(s) using the boom switch(es) to clear the error. 2. Clean or replace the sensor filters. If the error repeats, contact your Authorized Toro Distributor.