



MODEL NO. 41355 & 41356

SET-UP AND PARTS
MANUAL**ENCLOSED BOOM**

for use on the MULTI-PRO® 1100 VEHICLE

Refer to illustrated Parts List for details of parts used in assembling the ENCLOSED BOOM for use on the MULTI-PRO® 1100 VEHICLE.

NOTE: When installing the ENCLOSED BOOM on the MULTI-PRO® 1100, the instructions in this manual replace the "BOOM FRAME ASSEMBLY:"* section in the SET-UP & PARTS MANUAL for the following:

- PRO-CONTROL™ SPRAY SYSTEM FOR THE MULTI-PRO® 1100 VEHICLE
- MANUAL VALVE SPRAY SYSTEM FOR THE MULTI-PRO® 1100 VEHICLE
- STANDARD ELECTRIC SPRAY SYSTEM 1000 FOR THE MULTI-PRO® 1100 VEHICLE
- INJECTOR-PRO™ SYSTEM FOR THE MULTI-PRO® 1100

Also refer to the applicable Spray System SET-UP AND PARTS MANUAL for Control Valve installation and other Sprayer assembly requirements.

NOTE: "Right", "Left", "Front" and "Rear" are referenced while seated in the operator's position.

BOOM FRAME ASSEMBLY:

The Boom Frame Assembly instructions for the MULTI-PRO® 1100 with PRO-CONTROL™, MANUAL VALVE and STANDARD SPRAY SYSTEMS are described separately from the INJECTOR PRO™ SPRAY SYSTEM because of their differences. Follow the applicable directions for the installation.

NOTE: Wherever "grease" is referred to in this manual use a No. 2 General Purpose Lithium Base Grease.

BOOM FRAME ASSEMBLY FOR MULTI-PRO® 1100 WITH PRO-CONTROL™, MANUAL VALVE OR STANDARD ELECTRIC SPRAY SYSTEMS:

1. Apply a heavy coating of grease to the tubes of the two Boom Mount Assemblies and insert them into the Vehicle Frame as shown in FIG. 1 until the Stop Pins hit the Frame tubes.

NOTE: Note the position of the angle member of the Right and Left Boom Mount Assemblies in relation to the tube member. They must be positioned as shown for the mounting of the Cross Support Angle.

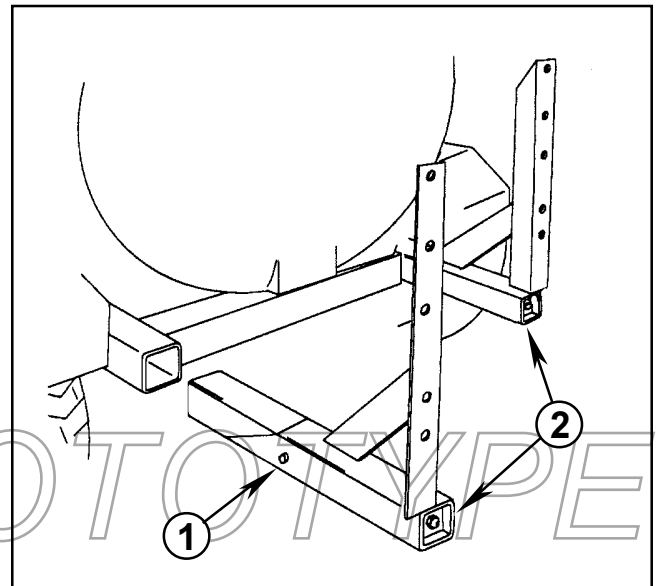

1. Stop Pin

FIG. 1

2. Boom Mount Assemblies

2. Assemble Flow Monitor and Flow Monitor Backing Plate onto the Flow Monitor Mount using (4) 1/4" x 2" hex hd. cap screws and lock nuts.

3. Assemble the Cross Support Angle, Flow Monitor Mount and Spacer onto the Boom Mount Assemblies with (2) 1/2" x 1-1/4" hex hd. cap screws and lock nuts as per FIG. 2.

4. Using a torque wrench, tighten the (2) 1/2" x 18" screws that join the Wedge Tubes to the boom Mounts. Tighten to 50 ft. lbs.

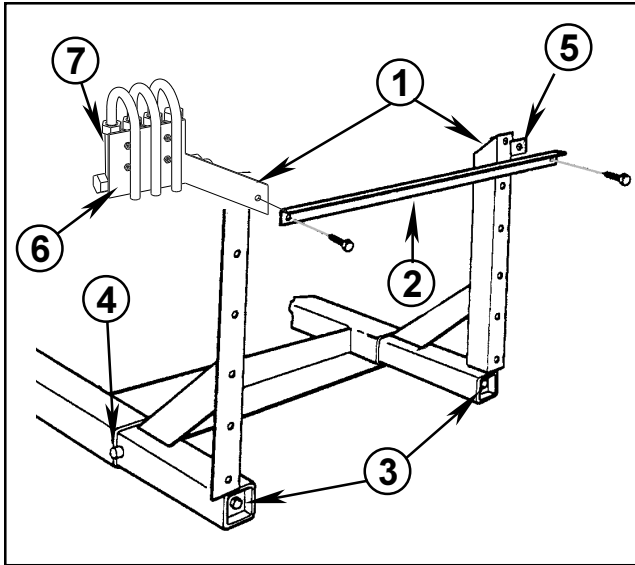

FIG. 2

- | | |
|------------------------|-----------------------|
| 1. Boom Mount Assy. | 5. Spacer |
| 2. Cross support Angle | 6. Flow Monitor Mount |
| 3. Wedge Screws | 7. Flow Monitor |

BOOM FRAME ASSEMBLY FOR THE INJECTOR-PRO™ SPRAY SYSTEM:

1. Apply a heavy coating of grease to the tubes of the two Boom Mount Assemblies and insert them into the Vehicle Frame as shown in FIG 3.

NOTE: If installing the Boom Mount Assemblies on the INJECTOR-PRO™ the Stop Pins need to be set flush with the square tube to allow the Boom Mount to slide all the way into the Vehicle Frame.

NOTE: Note the position of the angle member of the Right and left Boom Mount Assemblies in relation to the tube member. They must be positioned as shown for the mounting of the Cross Support Angle.

2. Assemble Flow Monitor and Flow Monitor Backing Plate onto the Flow Monitor Mount using (4) 1/4" x 2" hex hd. cap screws and lock nuts.

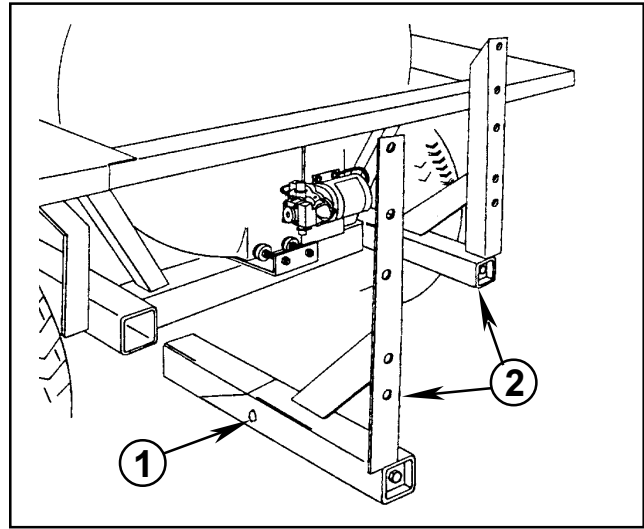

FIG. 3

1. Stop Pin (set flush) 2. Boom Mount Assemblies

3. Assemble the Cross Support Angle, Flow Monitor Mount and Flow Monitor Mount Extender Bracket onto the Boom Mount Assemblies with (2) 1/2" x 1-1/4" hex hd. cap screws and lock nuts as per FIG 4.

4. Assemble (2) R-Clamps and Hose Bracket complete with grommet onto the Flow Monitor Extender Bracket using (4) 5/16" x 3/4" UNC hex hd. cap screws and nuts.

NOTE: The parts used in step 4 are provided with the INJECTOR-PRO™. Also refer to the INJECTOR-PRO™ INSTALLATION INSTRUCTIONS.

5. Using a torque wrench, tighten the (2) 1/2" x 18" screws that join the Wedge Tubes to the Boom Mounts. Tighten to 50 ft. lbs.

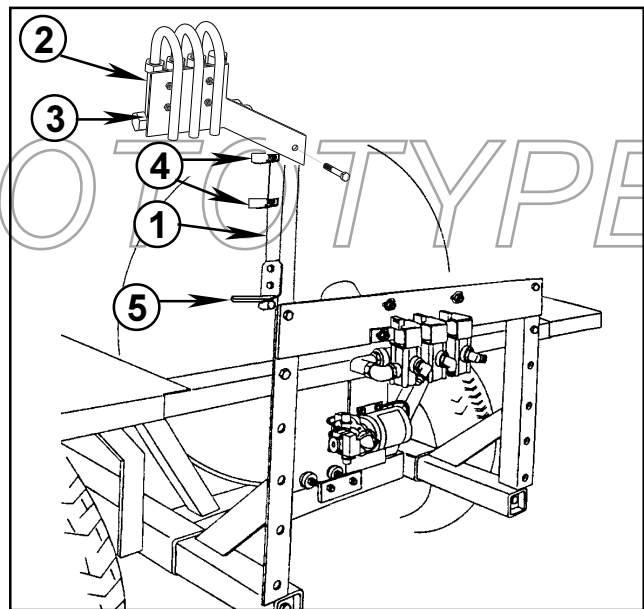



FIG. 4

- | | |
|-----------------|--|
| 1. Flow Monitor | 3. Flow Monitor Mount Extender Bracket |
| 2. Flow Monitor | 4. R-Clamp |
| | 5. Hose Bracket |

ELECTRIC BRAKE ASSEMBLY:

IMPORTANT: Before installing the Electric Brakes re-torque the Wheels nuts on the MULTI-PRO® 1100 rear Wheels to 75 ft. lbs. (100 N - m). Also refer to the MULTI-PRO® 1100 OPERATORS MANUAL for Wheel Nut torque instructions.

The nuts on the Electric Brakes and Brake Adapters must be torqued as per the specifications in this manual



CAUTION

- Wheel or Brake Mount failure could occur if proper nut torque is not maintained.
- Wheel or Brake Mount failure could result in serious injury or death.
- Torque nuts as per the specifications given in the SET-UP AND PARTS MANUAL or OPERATORS MANUAL.

1. Assemble the Adapter Plates onto the Brake Assembly Hubs with (4) 1/2" UNF wheel nuts as per FIG. 5. Torque nuts to 90 ft. lbs. (120 N-m).

NOTE: There is a Left and Right Brake Hub. The Brake Hubs must be assembled onto the Vehicle with the wire connector pointing to the rear of the Vehicle.

2. Assemble Right Brake Hub / Adapter Plate Assembly onto Right Wheel using (4) Spacers and (4) 1/2" X 4 1/2" carriage hd. bolts. Torque nuts to 90 ft. lbs. (120 N - m).

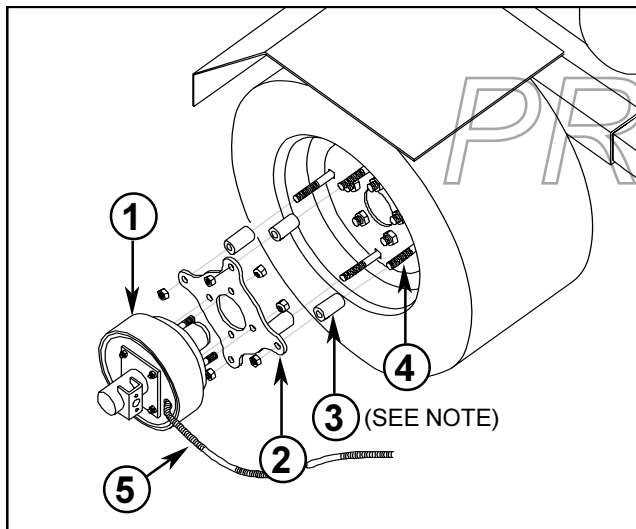

FIG. 5

- | | |
|-----------------------|---|
| 1. Brake Hub Assembly | 4. Retainer Bolts (Carriage Bolts used on right side) |
| 2. Adapter Plate | |
| 3. Spacer | 5. Wire Harness |

NOTE: If the MULTI-PRO 1100 Vehicle has a Serial No. under 70000 use the 1/2" I.D. x 2 11/16" long Spacers. If the MULTI-PRO 1100 Vehicle has a Serial No. 70000 and above use the 1/2" I.D. x 3 7/16" long Spacers.

NOTE: If the PRO-CONTROL™ SYSTEM or INJECTOR-PRO™ SYSTEM are being used, the Wheel Magnets for the Speed Sensor must be mounted on the ends of the Left Brake Hub / Adapter Plate Assembly Retainer Bolts. This is done by driving the roll pin out of the Wheel Magnet mounting stud (provided with the Speed Sensor assembly) and assembling the Magnets onto the Retainer Bolts (provided with the ENCLOSED BOOM). Place a drop of silicone sealant on the magnet mounting end of the retainer bolt and reinsert the roll pin to secure. FIG. 6

IMPORTANT! Magnets must be mounted in alternating red - black sequence.

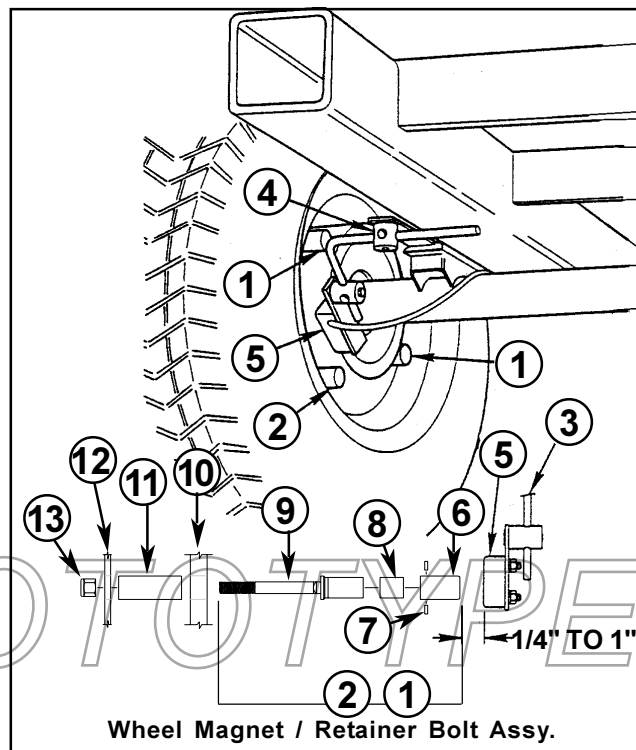

FIG. 6

- | | |
|-------------------------------|-----------------------------------|
| 1. Wheel Magnet Assy (Red) | 8. Magnet |
| 2. Wheel Magnet Assy. (Black) | 9. Retainer Bolt |
| 3. Sensor Rod | 10. Wheel Rim (Shown Cutaway) |
| 4. Turret Assembly | 11. Spacer |
| 5. Sensor Switch | 12. Adapter Plate (Shown Cutaway) |
| 6. Magnet Housing | 13. Nut |
| 7. Roll Pin | |

3. Assemble Left Brake Hub / Adapter Plate Assembly onto left Wheel using (4) Spacers and (4) 1/2" x 4 1/2" Retainer Bolts. Torque nuts to 90 ft. lbs. (120 N - m) .

CENTER BOOM AND MOUNT ASSEMBLY:

1. Assemble Right and Left Boom Mount(s) onto the Center Boom as per FIG. 7a using the (4) 1/2" x 3" / (2) 3/8" x 1-1/4" hex hd. cap screws and lock nuts. Do not tighten.

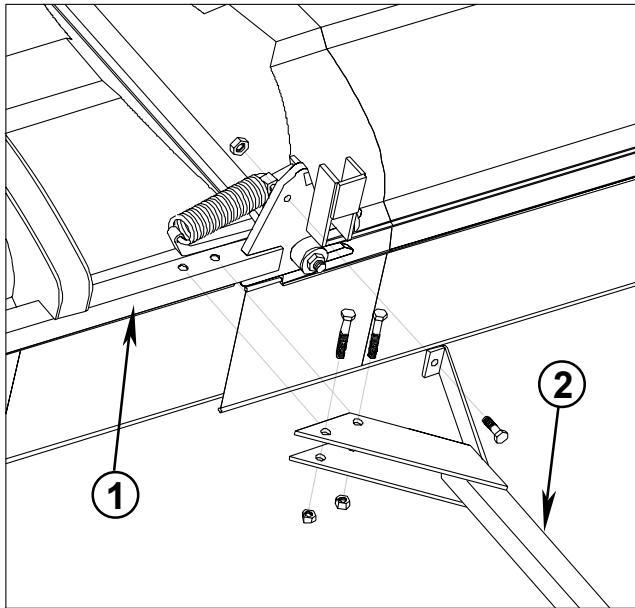

FIG. 7a

1. Boom Center Section 2. Boom Mount (left Shown)

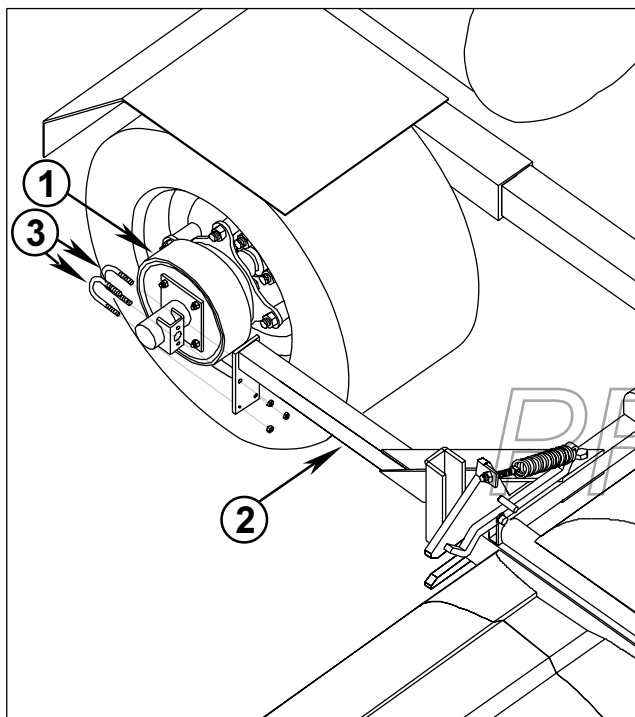

FIG. 7b

1. Brake Hub Assembly 3. U - Bolt
2. Boom Mount (Left Shown)

2. Assemble the Left and Right straight Castor Mounts into the rear of the Center Boom section using (4) 1/2" x 3" carriage hd. bolts and ensuring that bolt heads are on the "hood opening" side. The

Tow Hitch on the Left Castor Mount should face the Right Castor Mount. Assemble (2) Wheels onto (2) Castor Forks with the long shafts using (2) 3/4" O.D. x 6" bushings, (2) 1/2" x 7-1/2" hex hd. cap screws and lock nuts. Assemble Castor Forks onto Castor Arms using a spring and cotter pin on each castor. (Refer to Page 14)

3. Assemble Boom Mounts onto Brake Hub mounting shafts as per FIG. 7b using (2) U-clamps per Hub and ensuring that Boom is centered on the Vehicle. Tighten nuts on U-clamp and then tighten nuts on the (4) 1/2" x 2-1/2" and (2) 3/4" x 1-1/4" hex hd. cap screws.

BOOM EXTENSION ASSEMBLY:

1. Lay out the Left and Right Boom Extensions behind the sprayer approximately as the boom will be when assembled.

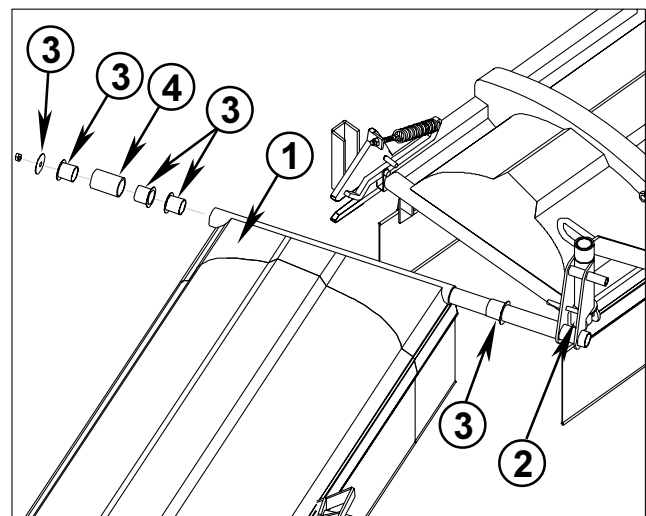

FIG. 8

1. Extension Boom 4. Breakaway Retainer Collar
2. Pivot Joint 5. Pivot Retainer Washer
3. Bushing

2. Assemble the (2) curved Castor Mounts into Right and Left Boom Extensions using (4) 1/2" x 3" carriage hd. bolts and ensuring that bolt heads are on the "hood opening" side. The Castor Mounts should curve toward the sprayer. Assemble Wheels onto (2) Castor Forks with the short shafts using (2) 3/4" O.D. x 6" bushings, (2) 1/2" x 7-1/2" hex hd. cap screws and lock nuts. Assemble Castor Forks onto Castor Arms using 3/16" x 1-1/2" cotter pins. (Refer to Page 14)

3. Lightly grease Right and Left Boom horizontal pivots where bushings will rotate. Assemble Right and Left Booms onto Boom Center Section / Horizontal Pivot Joint as per FIG. 8 ensuring that bushings are properly seated. Torque the wing retainer lock nuts to 25 ft. lbs.

4. Assemble Anti-scalp Castors onto back outer mount on Right and Left Booms using 7/16" lock nuts.

BOOM EXTENSION FEED HOSE ROUTING:

1. Fold the Right and Left Boom Extensions forward following the Boom Extension Forward Fold Instruction Decal located near the ends of the Boom Extensions. Also refer to Forward Fold instructions in OPERATORS MANUAL.

	<h3>CAUTION</h3>
<ul style="list-style-type: none"> • Use proper lifting procedures when lifting the Extension Boom into the forward fold position. • Failure to follow proper lifting procedures could result in personal injury. • Follow the Forward Fold Instruction Decal located near the end of the Boom Extension. • Also read and understand the instructions in OPERATORS MANUAL. 	

PLUMBING DIAGRAM

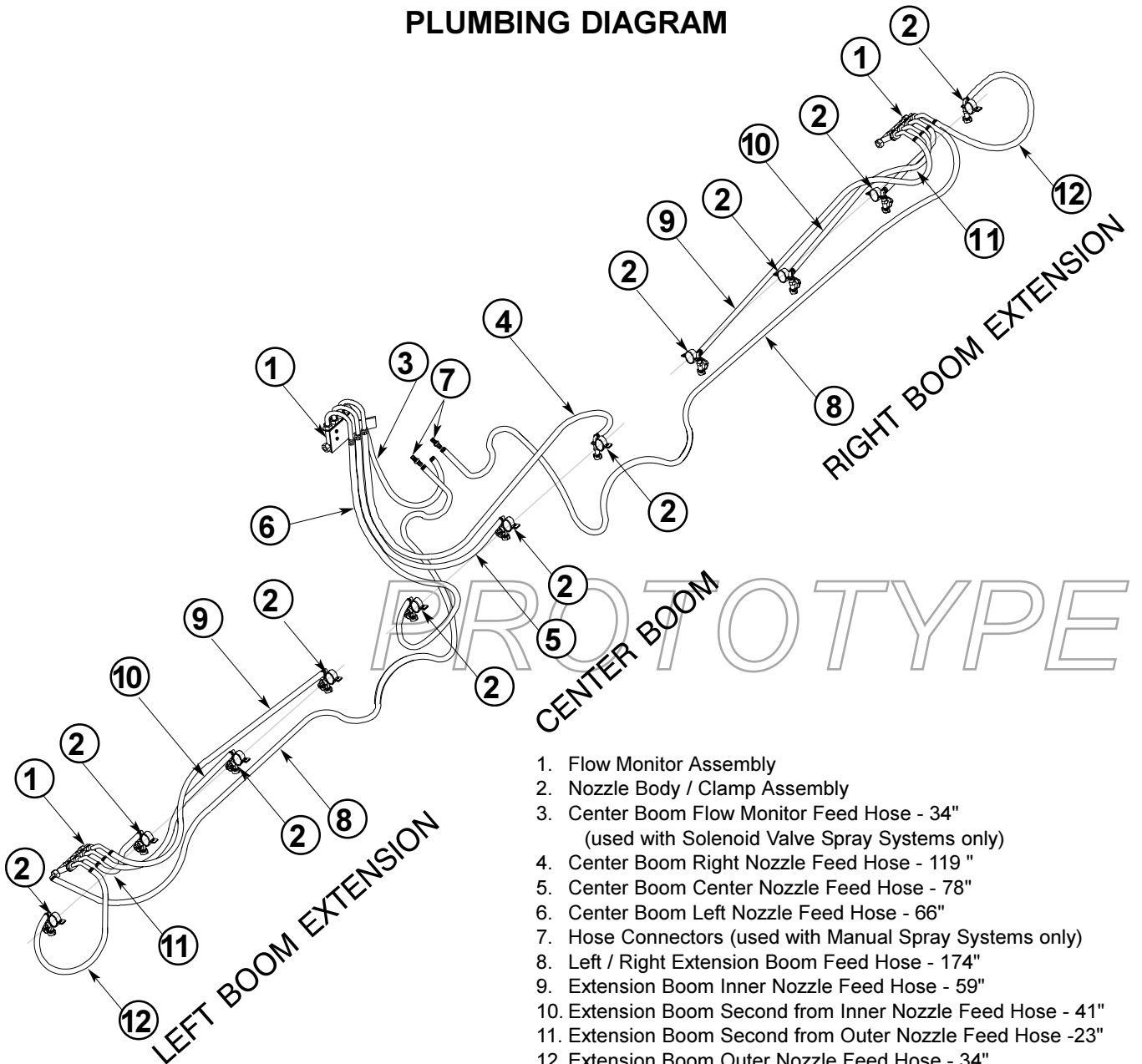

1. Flow Monitor Assembly
2. Nozzle Body / Clamp Assembly
3. Center Boom Flow Monitor Feed Hose - 34"
(used with Solenoid Valve Spray Systems only)
4. Center Boom Right Nozzle Feed Hose - 119"
5. Center Boom Center Nozzle Feed Hose - 78"
6. Center Boom Left Nozzle Feed Hose - 66"
7. Hose Connectors (used with Manual Spray Systems only)
8. Left / Right Extension Boom Feed Hose - 174"
9. Extension Boom Inner Nozzle Feed Hose - 59"
10. Extension Boom Second from Inner Nozzle Feed Hose - 41"
11. Extension Boom Second from Outer Nozzle Feed Hose - 23"
12. Extension Boom Outer Nozzle Feed Hose - 34"

2. Route Right and Left Boom Feed Hoses as shown in FIG. 9 and FIG. 10 through retainer ring at the Boom Extension Pivot Joint and through Center Boom section ensuring that there is adequate hose length at the Boom Extension Pivot Joint so that the hose is not stretched.

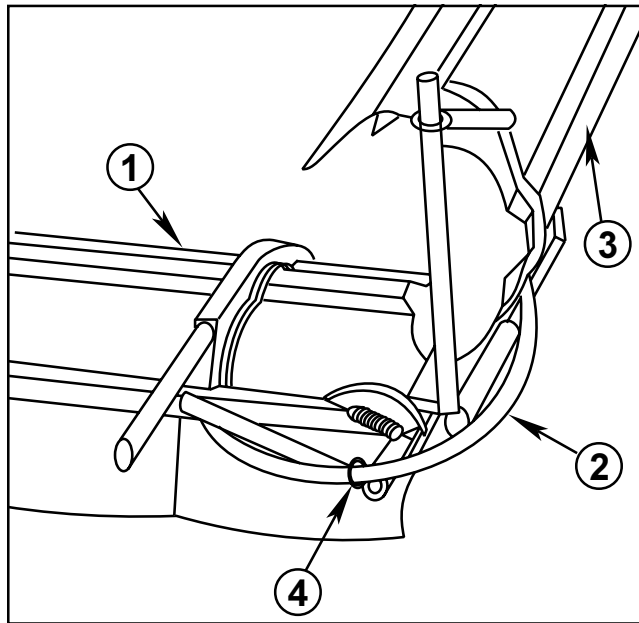

FIG. 9

- | | |
|-----------------------------|-------------------|
| 1. Boom Center Section | 3. Boom Extension |
| 2. Extension Boom Feed Hose | 4. Retainer Ring |

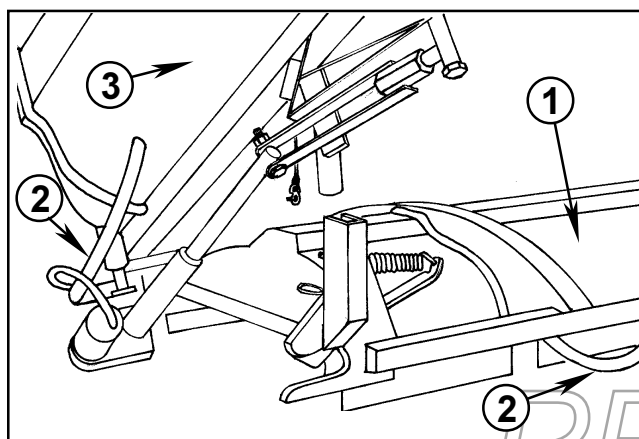

FIG. 10

- | | |
|-----------------------------|-------------------|
| 1. Boom Center Section | 3. Boom Extension |
| 2. Boom Extension Feed Hose | |

3. Unfold the booms and insert into Breakaway Latches to put in field position.



CAUTION

- Chemicals are hazardous and can cause personal injury!
- Securely tighten all sprayer hose clamp connections during initial set-up to prevent leaks and hose blow-offs while spraying system is in operation.

HOSE CONNECTIONS:

1. Connect the 3 hoses for the Center Boom to the Center Flow Monitor so that the monitor indicators correspond to the Spray Nozzles on the Center Boom (i.e. left nozzle on left flow indicator, etc.).

2. Tie hoses together and then secure to the lower part of the Flow Monitor Mount with a tie strap so that the weight or movement of the hoses does not put any strain on the Flow Monitor.

NOTE: The Boom Control Valves must be installed on the sprayer before the rest of the hose connection step can be completed. The Boom hose connection will depend on the type of Control Valve system used on the Sprayer. Refer to the applicable SPRAY SYSTEM SET-UP AND PARTS MANUAL for the Control Valve installation.

SPRAYERS WITH ELECTRIC SOLENOID CONTROL VALVE SYSTEM:

1. Connect the 34" length of 3/4" Hose included with the Enclosed Boom to the inlet on the Center Boom Flow Monitor and the other end to the outlet on the center Solenoid Valve. Secure with Hose Clamps.

2. Connect the Boom Feed Hoses for the Left and Right Boom Extensions to the outlets on the Solenoid Control Valves so that the Boom Feed Hoses supply the corresponding boom sections controlled by the Boom Control Switches / Solenoid Control Valves. Secure with Hose Clamps.

SPRAYERS WITH MANUAL CONTROL VALVE SYSTEM:

1. Connect the Feed Hose from the Manual Control Valve for the Center Boom to the inlet for the Center Boom Flow Monitor, trimming excess hose.

2. Insert the (2) 3/4" Hose Connectors supplied with the boom into the Feed Hoses for the Left and Right Booms. Secure with Hose Clamps. Connect the Feed Hoses coming from the Left and Right Boom Control Valves to the Hose Connectors, trimming excess hose, but allowing enough hose length for boom movement. Secure with Hose Clamps.

NOTE: The Flow Monitor Swivel Nuts should be tightened at this time. Be Careful not to overtighten.

WIRING DIAGRAM

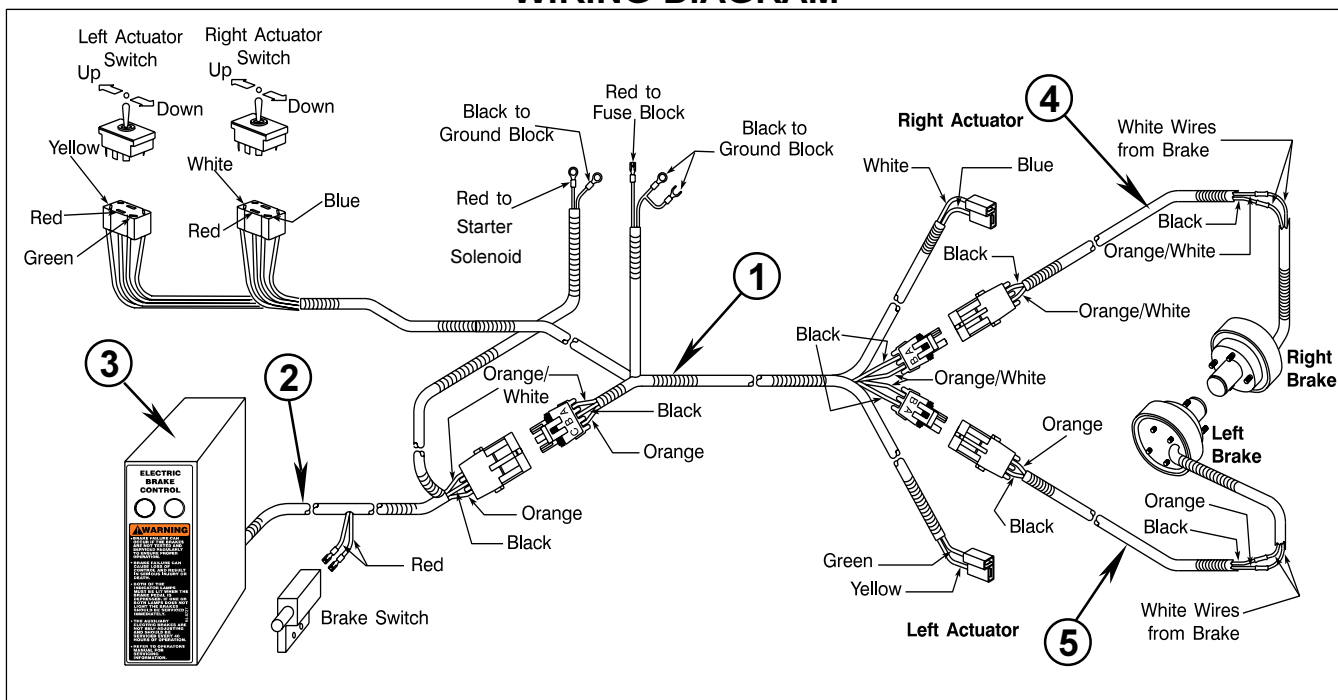

1. Wiring Harness - Vehicle

2. Wiring Harness - Brake Controller

3. Brake Controller

4. Brake Lead - Right

5. Brake Lead - Left

WIRING HARNESS INSTALLATION:

1. Connect the Wiring Harness connectors to the Switches as shown in the **WIRING DIAGRAM**. Install the Switches in the holes in the seat support, as per FIG. 11, using the nuts included with the Switches. Install the protective rubber Boots. Apply the "UP/DOWN" decal between the Switches.

2. Connect the push-on terminal on the red wire coming from the Wiring Harness to the connector on the red wire coming from the fuse block. Ground the spade terminal on the black wire to the Ground Terminal Block. See FIG. 12.

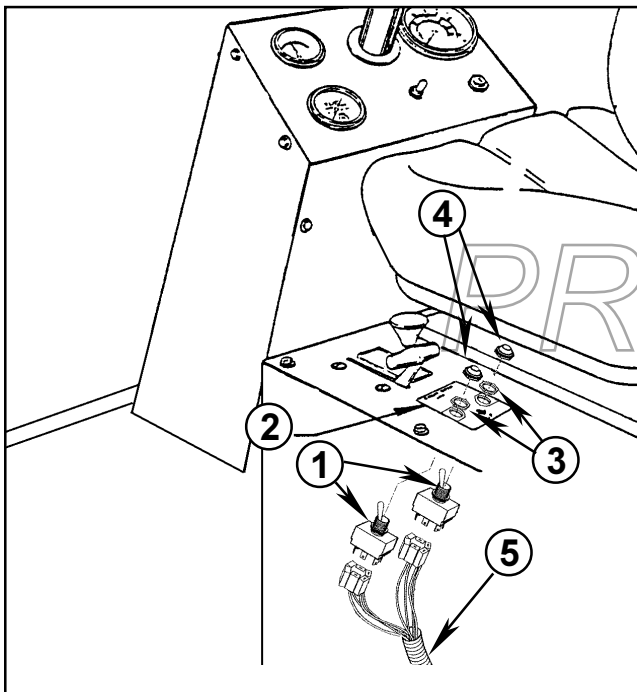

FIG. 11

1. Boom Switches

2. Decal

3. Nuts

4. Protective Rubber Boots

5. Wire Harness

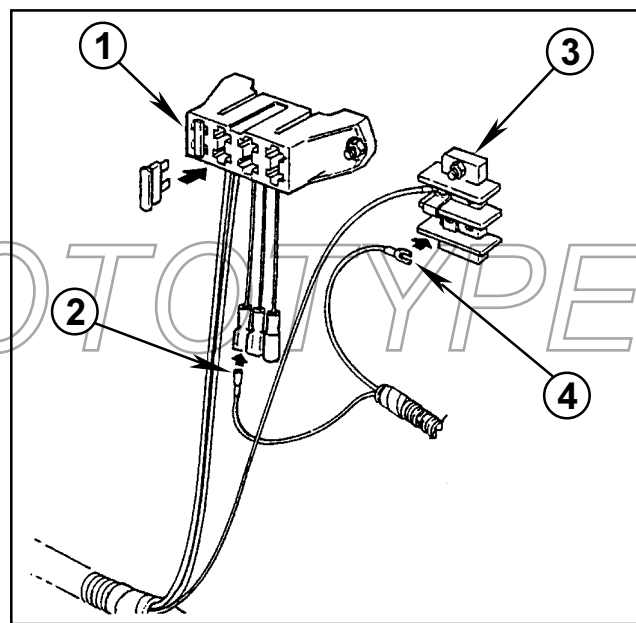

FIG. 12

1. Fuse Block

2. Push-On Terminal

3. Ground Term. Block

4. Spade Terminal

3. Route down the forward, left corner of the engine compartment to the left round hole in the Cross Member on the Vehicle Frame. The male three pin connector should be positioned at the hole in the Cross Member. Route the Wiring Harness to the back of the Vehicle along the retainer rings on the left side of the Vehicle Main Frame. The Brake Connectors should be positioned in the middle at the back.

Route the leads for the Right and Left Boom Lift Actuators along the Boom Wing Feed Hoses out to where the Actuators will be located.

4. Secure the Wire Harness, with plastic cable ties, to the Vehicle Frame.

ELECTRIC BOOM EXTENSION LIFTS:

1. Assemble the Boom Extension Electric Lift Adjustment Links onto the Left and Right Booms using 1/2" x 8" hex hd. cap screws and locknuts. Assemble Electric Actuators onto the Extension Breakaway Pivots using the 1/2" x 5" hex hd. cap screws and locknuts. Connect the other end of the Actuator to the Actuator Adjustment Link using the 1/2" x 2" hex hd. cap screws and lock nuts. FIG. 13.

NOTE: The locknuts should only be tight enough to retain the cap screws, allowing the Actuator and Actuator Adjustment Link to pivot freely.

Ensure that the Actuator Drive Motors are on top.

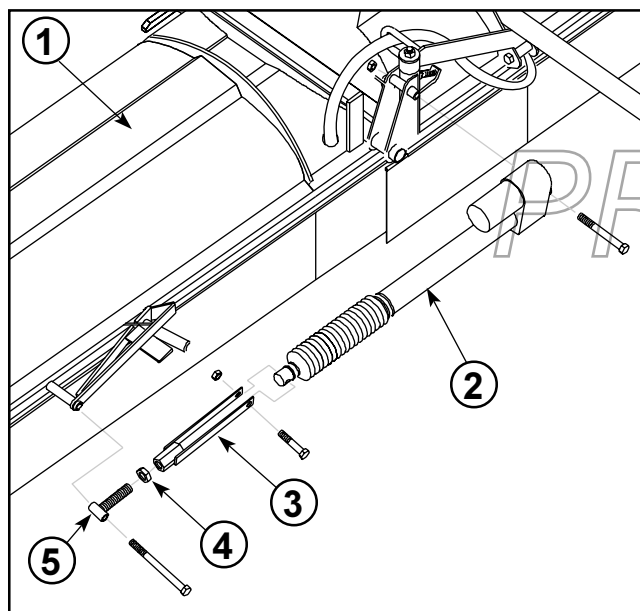

FIG. 13

- | | |
|-----------------------------------|------------------------|
| 1. Boom Extension
(Left Shown) | 4. Jam Nut |
| 2. Actuator | 5. Actuator Adjuster T |
| 3. Actuator Adjustment Link | |

2. Make a trial connection by plugging single terminals into the Actuator Plug, to check the up and down motion and the right and left control at the Boom Switches.

3. When all connections are correct, disconnect the terminals and slide them into the corresponding slots of the plastic connectors and connect to Actuator Plugs.

4. Apply silicone sealer at connection and on the back side of all plugs at wire entry.

IMPORTANT: The Electric Boom Extension Lifts must be properly adjusted to operate correctly. Improper adjustment could damage the Boom.

! CAUTION

- The adjustment of the Electric Boom Extension Lifts requires that the Actuator be separated from the Actuator Adjustment Link which leaves the Boom Extension unsupported.
- An unsupported Boom Extension could fall and cause personal injury or death.
- Use additional support for the Boom Extension when adjusting the Electric Boom Extension Actuator.
- It is recommended that the Boom Extension Electric Lift adjustments be done with two people.

5. Use the Up/Down switches to raise the Boom Extension to the upright position until the Stop on the front corner of the Boom Extension just makes contact with the contact pad on the Center Boom.

6. Measure the length of the Actuator. It should be 17-1/8" ± 1/16" from the face of the Actuator Front Housing to the center of the cap screw. (FIG. 14.)

7. If the measurement is incorrect remove the hex hd screw that attaches the Actuator Link to the Actuator, loosen the Jam Nut and rotate the Actuator Adjustment Link to change the length to the specification. Replace the hex hd screw and nut ensuring that the link can pivot freely. Retighten the Jam Nut, ensuring that the Actuator Link rests squarely on the Actuator Link Stop in the raised position.

NOTE: If the Actuator has more than the above specification this will bend the frame of the Extension Boom when the Actuator is fully contracted. Less than specification will cause excessive movement during vertical transport.

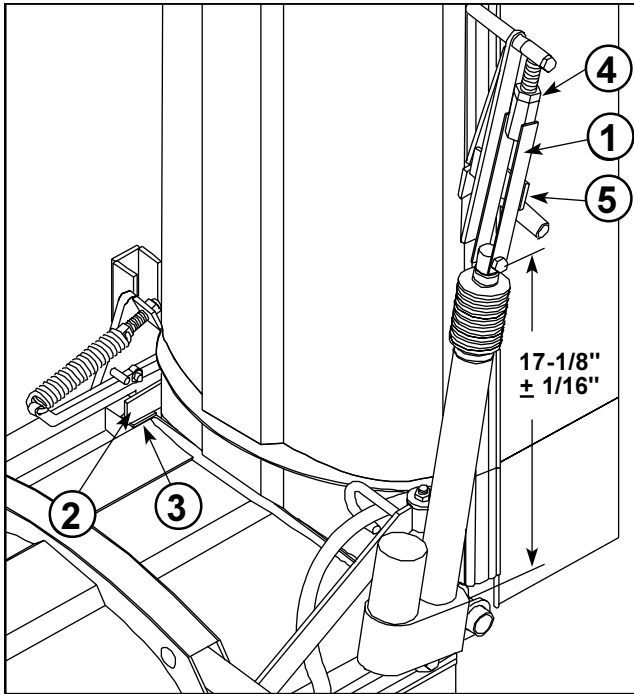

FIG. 14

- | | |
|-----------------------------|-----------------------|
| 1. Actuator Adjustment Link | 4. Jam Nut |
| 2. Stop | 5. Actuator Link Stop |
| 3. Contact Pad | |

ELECTRIC BRAKE CONTROLLER INSTALLATION:



WARNING

Brake failure can cause loss of control and result in serious injury or death.

Both of the indicator lamps must be lit when the brake pedal is depressed. If one or both lamps does not light the brakes should be serviced immediately.

The auxiliary electric brakes are not self-adjusting and should be serviced every 40 hours of operation.

Failure to service brakes could result in serious injury or death.

Refer to OPERATORS MANUAL for servicing information.

1. Remove (4) 1/4" x 5/8" washer hd. cap screws to remove Rear Panel on Steering Console. Remove the Knock-out Plug in the front of the Steering Console and insert the Large Grommet as per FIG. 15.

2. Mount Brake Controller on right side of steering column by removing (2) 1/4" bolts and reassembling with Controller as shown in FIG. 15 using (4) 1/4" flat washers, (2) 1/4" spring washers and (2) 1/4" x 3/4" socket hd cap screws. Install Hole Plugs in holes.

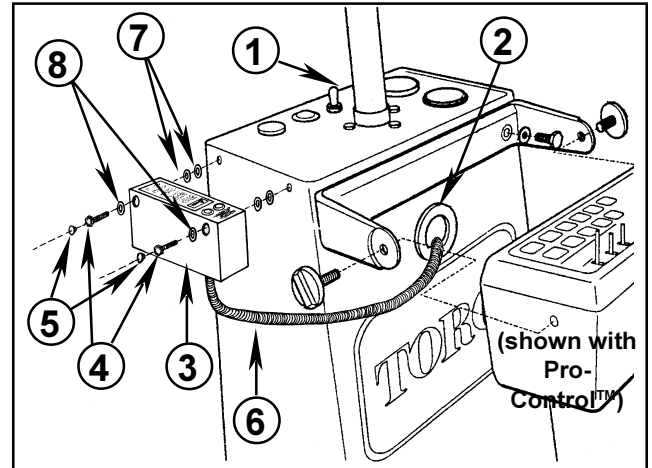

FIG. 15

- | | |
|-------------------------|------------------|
| 1. Steering Column | 5. Hole Plugs |
| 2. Grommet | 6. Wire Harness |
| 3. Brake Controller | 7. Flat Washer |
| 4. Socket hd Cap Screws | 8. Spring Washer |

3. Assemble the Brake Switch onto the Brake Switch Mounting Bracket using the (2) 3/16" x 3/4" hex hd. cap screws and lock nuts. Assemble Brake Switch Mounting Bracket onto Brake Arm Assembly by removing the (2) 5/16" hex hd cap screws on the side of the Brake Pedal Mount (Refer to MULTI-PRO® 1100 PARTS MANUAL - Brake Pivot Assembly Part No. 42754). Place the Brake Switch Mounting Bracket on the outside so that the Brake Arm activates the switch when the Brake Pedal is depressed and reinstall the hex hd cap screws as per FIG. 16. The Brake Switch should be adjusted so that the Electric Brakes engage when the Brake Pedal is depressed 1/8" - 1/4". This can be done by pivoting the Brake Switch Mounting Bracket and then tightening 5/16" hex hd screws.

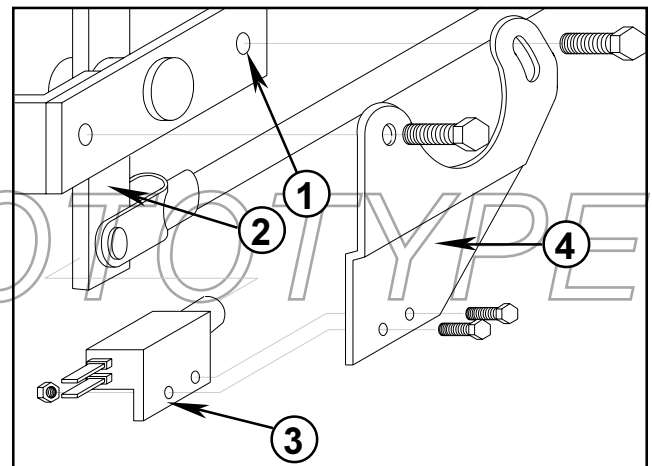

FIG. 16

- | | |
|-----------------------|----------------------------------|
| 1. Pivot Assembly | 3. Brake Switch |
| 2. Brake Arm Assembly | 4. Brake Switch Mounting Bracket |

4. Route Wiring Harness from Brake Controller through Grommet and down inside of Steering Console. Connect to Brake Switch connectors. Route wiring through leaf spring retainer bracket and to the round hole in the Cross Member on the left side of the Vehicle Frame. Refer to FIG. 15 and the WIRING DIAGRAM on page 7.

5. Connect the male three pin connector on the main Wiring Harness to the Female plug on the Brake Controller wiring harness.

6. Connect the Red Wire Ring Terminal connector to the same terminal as the red Power Wire located at the lower rear of the Starter Solenoid.

NOTE: Ensure that the terminal you are connecting to is the one directly connected to the battery and has 12 volts (nominal) at all times.

Connect the Black Wire Ring Terminal to the 5/16" x 3/4" Hex Hd. Cap Screw located at the lower right hand corner of the Left Hand Side Panel. (Also refer to the MULTI-PRO® 1100 Parts Manual)

7. Secure the Wire Harness, with plastic cable ties, to the Vehicle Frame.

8. Replace Rear Panel on Steering Console and reinstall (4) 1/4" x 5/8" washer hd. cap screws.

ELECTRIC BRAKE WIRING CONNECTION:

1. Route the wiring harnesses coming out of the back of the Left and Right Brakes along the Boom Mounting Bracket and the square tube on the front of the Center Boom. Connect to the two pin Connector Plugs at the back of the right side of the Vehicle.

NOTE: The Connector for the Right Brake has the Orange & White wire. The Connector for the Left Brake has an Orange wire.

Confirm that the plugs are connected correctly by stepping on the brake pedal and observing the Brake Operation Indicator Lights on the Brake Controller. The lights will only come on if power is flowing to the brake.

IMPORTANT: Readjust the Brake Switch position if necessary so that the Electric Brakes engage as soon as the Brake Pedal is pressed. The Electric Brakes should engage before the vehicle brakes.

FOAM MARKER OPTION:

NOTE: The installation of the optional Foam Marker on the ENCLOSED BOOM requires that one alternative step, and one additional step be done when compared to the SET-UP AND PARTS LIST included with the FOAM MARKER KIT for use on the MULTI-PRO® 1100 VEHICLE.

Follow the instructions included with the **FOAM MARKER KIT** except for the applicable steps as follows:

1. The installation of the Foam Marker with the **EXTENSION BOOM** on the **MULTI-PRO® 1100** requires that the **9/32"** hole, which must be drilled in the Right and Left Boom Pipes, be located on the **bottom** side of the tube **5" over from the hood opening** as per FIG. 17.

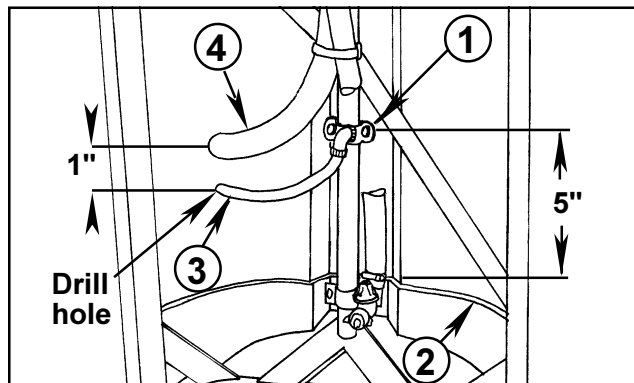

FIG. 17

- | | |
|---------------------------|-----------------------------|
| 1. Split Eyelet Connector | 3. Foam Marker Hose |
| 2. Hood Opening | 4. Boom Extension Feed Hose |

2. Drill 5/8" hole in the plastic shroud 1" over from the Boom Feed Hose on each Boom Extension.

3. Additional hose is required to install the Foam Marker on the **ENCLOSED BOOM** which is included with the **ENCLOSED BOOM**. Connect the 78" length of 3/8" Hose supplied with **ENCLOSED BOOM** to the Split Eyelet Connector on the boom, secure with Hose Clamp provided with **FOAM MARKER KIT**. Route the Hose with the Right and Left Boom Feed Hose to the front of the Center Boom, securing Foam Marker Hose to Boom Feed Hose and Actuator Wire Harness with Plastic Ties, ensuring that Ties do not squash Hoses.

4. Connect to Foam Marker Boom Feed Hoses coming from Compressor using (2) 3/8" Hose Connectors and (4) Hose Clamps supplied with the **ENCLOSED BOOM**.

RINSEATE NOZZLE MOUNT:

NOTE: If the INJECTOR-PRO™ SYSTEM is being installed, the Rinseate Nozzle must be mounted on the Center Boom section Left Castor Mount as per the following instructions:

1. Assemble the Rinseate Nozzle Mounting Bracket on to the Left Castor Mount of the Center Boom as per FIG. 18. Assemble the Rinseate Nozzle, 1/2" Female Pipe Coupling and 1/2" 90° Male Hose Coupling included with the Enclosed Boom Mounting Kit. (refer to the Single Nozzle Assembly in the INJECTOR-PRO™ SYSTEM PARTS MANUAL). Mount Nozzle Assembly onto Mounting Bracket using (1) R-Clamp and 1/4" x 3/4" hex hd. cap screw, flat washer, lock washer and nut.

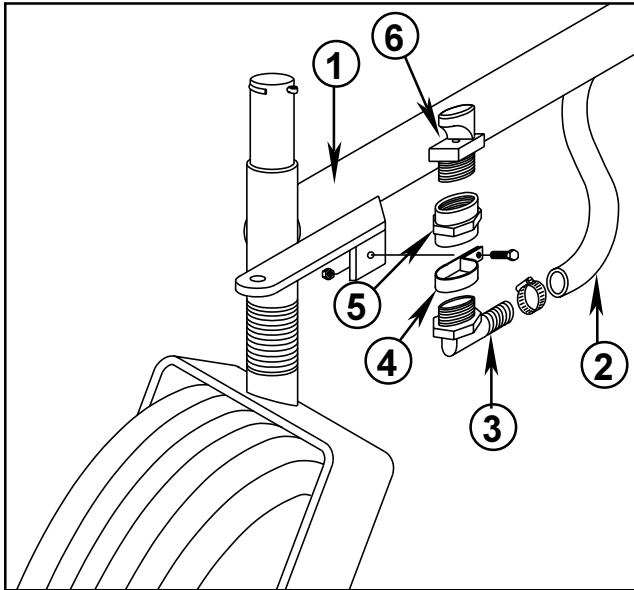

FIG. 18

- | | |
|-----------------------------------|------------------------------|
| 1. Left Castor Mount | 4. Vinyl R-Clamp |
| 2. Rinseate Feed Hose (from Pump) | 5. Female Pipe Coupling-1/2" |
| 3. Elbow Fitting | 6. Nozzle |

2. Assemble the 83" length of 1/2" EVA reinforced hose onto the Rinseate Nozzle inlet fitting and secure with hose clamp. Route the hose along the Castor Mount and then follow the Left Boom Wing Feed Hose through the Boom Center section. Connect the hose to the outlet side of the Rinseate Pump. Secure with Hose Clamp.

SECURING HOSE AND WIRING:

1. Tie Boom Feed Hose, Foam Marker Hose and Actuator Wiring Harness together with Plastic Ties every 8-10" ensuring that Ties do not squash Hose. At the Boom Extension Pivot Joint ensure that the hose does not collapse or interfere with boom movement in the field, vertical transport or forward fold transport positions. Where Hoses and wiring go through Center Boom, secure to boom frame so hoses cannot interfere with spray pattern or Boom operation.

2. Tie or secure all other hose and wiring so that it will not interfere with Boom operation.

DRIFT SEAL INSTALLATION:

1. Assemble the Drift Seal sections into the Retainer Molding slots located on the lower edge of the Boom. The longer pieces will be easier to install if a light lubricant such as liquid soap or a silicone based product (i.e. ARMOR-ALL) is used. FIG. 19. The end of the Drift Seal at the Hood opening should be flush with the Drift Seal Retainer Molding.

NOTE: At the Boom Pivot Joints the Drift Seal should overlap. At these points the Drift Seal will extend out of the Retainer Slot approximately 2-1/2".

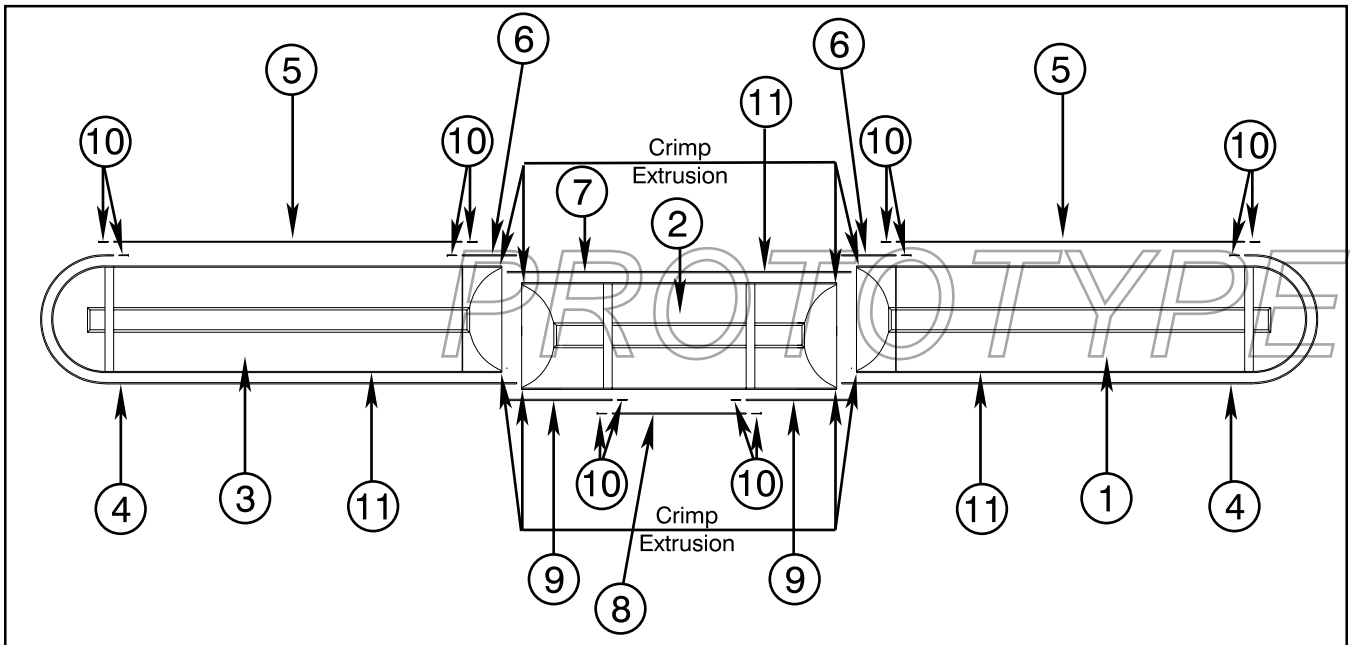

FIG. 19

- | | |
|---|--|
| 1. Right Boom Extension | 7. Center Boom Drift Seal - Front (68") |
| 2. Center Boom | 8. Center Boom Drift Seal - Hood (30-3/8") |
| 3. Left Boom Extension | 9. Center Boom Drift Seal - Rear (19") |
| 4. Boom Extension Drift Seal - Rear (113") | 10. Retainer Screw |
| 5. Boom Extension Drift Seal - Hood (65-1/2") | 11. Retainer Molding |
| 6. Boom Extension Drift Seal - Front (7-1/2") | |

2. Screw (12) #10 x 2" Drift Seal Retainer Screws into ends of curtain setting head of screw flush with Retainer Molding. Where Drift Seal overlaps and screws can not be used, crimp the end of the Retainer Molding 1/8" using Vice Grip pliers (put tape on jaws to prevent scuffing).

BEFORE OPERATING:

IMPORTANT! Grease inside surfaces of Transport Pin Receivers. Also grease Castor Fork Bushings and Wheel Bushings.

Refer to Operators Instructions for proper operating procedures.

Insert **SET-UP AND PARTS MANUAL** and **OPERATIONS MANUAL** into Vehicles Manual Holder.

NOTES:

PROTOTYPE

SAFETY AND INSTRUCTION DECALS

**ELECTRIC
BRAKE
CONTROL**

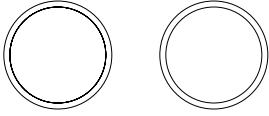

! WARNING

- BRAKE FAILURE CAN OCCUR IF THE BRAKES ARE NOT TESTED AND SERVICED REGULARLY TO ENSURE PROPER OPERATION.
- BRAKE FAILURE CAN CAUSE LOSS OF CONTROL AND RESULT IN SERIOUS INJURY OR DEATH.
- BOTH OF THE INDICATOR LAMPS MUST BE LIT WHEN THE BRAKE PEDAL IS DEPRESSED. IF ONE OR BOTH LAMPS DOES NOT LIGHT THE BRAKES SHOULD BE SERVICED IMMEDIATELY.
- THE AUXILIARY ELECTRIC BRAKES ARE NOT SELF-ADJUSTING AND SHOULD BE SERVICED EVERY 40 HOURS OF OPERATION.
- REFER TO OPERATORS MANUAL FOR SERVICING INFORMATION.

94-8727

Part No. 94-8727
Located on the Electric Brake Control.

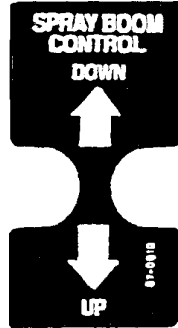

Part No. 87-0610
Located on the Top Panel - L.H. to the left of the seat.

! CAUTION

IMPROPER LIFTING PROCEDURE WHEN FORWARD FOLDING THE BOOM EXTENSION COULD RESULT IN PERSONAL INJURY.

FOLLOW THE FORWARD FOLD INSTRUCTIONS DECAL LOCATED NEAR THE END OF THE BOOM EXTENSION.

ALSO READ AND UNDERSTAND THE INSTRUCTIONS IN OPERATORS MANUAL.

94-8703

Part No. 94-8703 Located on Boom Extension Hoods



! WARNING

PINCH POINT

94-8701

Part No. 94-8701 Located on Center Section Ends and on Boom Extension Hoods near Actuator Link.

FORWARD FOLD INSTRUCTIONS.
NOTE: ACTUATOR MUST BE FULLY EXTENDED TO FORWARD FOLD EXTENSION BOOM



PULL OUT OF
BREAKAWAY LATCH



ROTATE BACK TO
STOP



STAND UP HOLDING
BOOM AT CHEST
HEIGHT

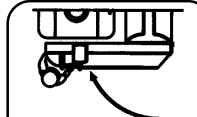

FOLD BOOM
PARALLEL TO
SPRAYER



INSERT RED PIN INTO
RED RECEPTACLE AND
FASTEN SAFETY LOCK.

94-8702

Part No. 94-8702 Located on Boom Extension curved Castor Wheel Mount

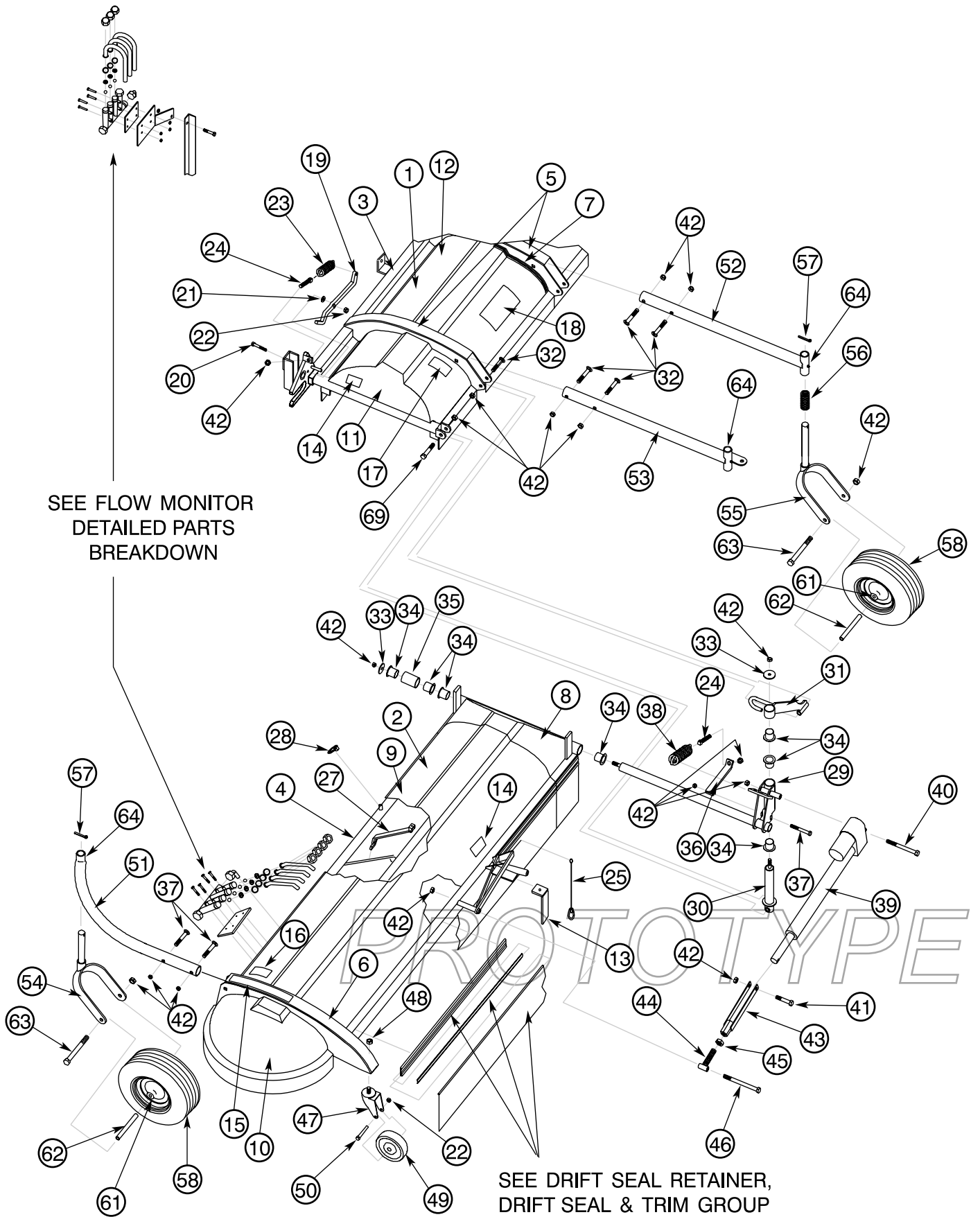

FRAME & SHROUD GROUP

Ref	Part No.	Description	Qty
1	94-8645	Boom Center Section Including: Main Frame - Center Left Shroud End Cap Right Shroud End Cap Center Shroud Hood Bumper Strip - 2 of Joint Seal - 2 of Drift Seal Retainer - Center Boom - Front Drift Seal Retainer - Center Boom - Hood Drift Seal Retainer - Center Boom - Rear Red Vinyl Insert - Center Boom - Front Red Vinyl Insert - Center Boom - Hood Red Vinyl Insert - Center Boom - Rear Hood support assy. Breakaway Latch - 2 of Hex hd cap screw, 3/8" NC x 2" -2 of Flat Washer - 3/8" - 6 of Locknut, 3/8" NC - 2 of Extension spring - Breakaway - 2 of Spring Adjuster Screw, 1/2" NC x 2" - 2 of Locknuts, 1/2" NC - 2 of Decal - Pinch Point Warning - 2 of Decal - GVW Warning Toro Decal	1
	94-8646	Boom Extension - Right - Including: (Not shown) Main Frame - Right Inner Shroud Cap - Left Boom Extension Boom Extension Shroud Hood Outer End Cap Shroud - Boom Extension - Left Bumper Strip Drift Seal Retainer - Boom Extension - Front Inner Drift Seal Retainer - Boom Extension - Front Outer Drift Seal Retainer - Boom Extension - Hood Drift Seal Retainer - Boom Extension - Rear Red Vinyl Insert - Boom Extension - Front Inner Red Vinyl Insert - Boom Extension - Front Outer Red Vinyl Insert - Boom Extension - Hood Red Vinyl Insert - Boom Extension Hood support assy. Quick Pin - 2 of Retainer Cable & Retainer Clip - Boom Extension Safety Decal - Pinch Point Warning Decal - Forward Fold Instruction Decal - Lift Caution	1

Ref	Part No.	Description	Qty
		Drift Seal Retainer - Boom Extension - Rear Red Vinyl Insert - Boom Extension - Front Inner Red Vinyl Insert - Boom Extension -Front Outer Red Vinyl Insert - Boom Extension -Hood Red Vinyl Insert - Boom Extension Hood support assy. Quick Pin - 2 of Retainer Cable & Retainer Clip - Boom Extension Safety Decal - Pinch Point Warning Decal - Forward Fold Instruction Decal - Lift Warning	
2	94-8647	Boom Extension - Left - Including: Main Frame - Left Inner Shroud Cap - Left Boom Extension Boom Extension Shroud Hood Outer End Cap Shroud - Boom Extension - Left Bumper Strip Drift Seal Retainer - Boom Extension - Front Inner Drift Seal Retainer - Boom Extension - Front Outer Drift Seal Retainer - Boom Extension - Hood Drift Seal Retainer - Boom Extension - Rear Red Vinyl Insert - Boom Extension - Front Inner Red Vinyl Insert - Boom Extension - Front Outer Red Vinyl Insert - Boom Extension - Hood Red Vinyl Insert - Boom Extension Hood support assy. Quick Pin - 2 of Retainer Cable & Retainer Clip - Boom Extension Safety Decal - Pinch Point Warning Decal - Forward Fold Instruction Decal - Lift Caution	1

FRAME & SHROUD GROUP

Ref	Part No.	Description	Qty
3	95-2058	Main Frame - Center	1
	95-2059	Main Frame - Right (Not shown)	1
4	95-2060	Main Frame - Left	1
5	94-8711	Bumper Strip-Center Section - 26"	2
6	94-8712	Bumper Strip-Boom Extension - 29-1/2"	2
	95-2129	Bumper Strip - Boom Extension -Front - 3" (not shown located under Castor Mount)	2
7	95-2080	Joint Seal - 26-1/4"	20
	32144-74	#6 x 3/8" Pan hd CW Self Tapping (not shown used with Joint Seal)	1
8	94-8684	Inner Shroud Cap - Left Boom Extension - plastic only	1
	94-8685	Inner Shroud Cap - Right Boom Extension - plastic only (Not shown)	2
9	94-8686	Boom Extension Shroud Hood - Left Boom - plastic only	1
	95-2130	Boom Extension Shroud Hood -Right Boom - plastic only (not shown)	1
10	94-8688	Outer End Cap Shroud - Boom Extension - Left - plastic only	1
	94-8689	Outer End Cap Shroud - Boom Extension - Right - plastic only (Not shown)	1
11	94-8698	Center Section Shroud End Cap - Left- plastic only	1
	94-8699	Center Section Shroud End Cap - Right - plastic only (Not shown)	1
12	94-8687	Center Section Shroud Hood - plastic only	2
13	95-2004	Drift Seal Stop	4
14	94-8701	Decal - Pinch Point Warning	2
15	94-8702	Decal - Forward Fold Instruction	1
16	94-8703	Decal - Lifting Caution	1
17	94-8609	Decal - GVW	2
18	62-5550	Toro Decal	2
19	94-8649	Breakaway Latch	2
20	323-9	Hex hd cap screw, 3/8" NC x 1-3/4"	2
21	3256-4	Flat Washer - 3/8" (3 req'd per side)	6
22	3296-59	Locknut, 3/8" NC	2
23	94-8675	Extension Spring - Breakaway	2
24	95-2061	Spring Adjuster Screw, 1/2" NC x 2"	3
25	94-8708	Retainer Clip - c/w Retainer Cable	2
27	94-8668	Hood Support Assembly: Support Latch - one of Pivot Mount - one of Pivot Pin - one of Cotter Pin - one of	4
28	92-1248	Quick Pin - Boom Ext Hood - 3/16" c/w Retainer Ring	1

BOOM EXTENSION PIVOT JOINT GROUP

Ref	Part No.	Description	Qty
29	94-8678	Boom Extension Breakaway Pivot - Left	1
	94-8679	Boom Extension Breakaway Pivot - Right (Not shown)	1
30	94-8680	Boom Extension Breakaway Pivot Pin	2
31	94-8681	Boom Extension Breakaway Pivot Support - Left	1
	94-8682	Boom Extension Breakaway Pivot Support - Right (Not shown)	1
69	325-10	Hex hd cap screw, 1/2" x 2-1/2"	2
32	3233-6	Carriage Bolt, 1/2" NC x 3"	2
42	32146-13	Locknuts, 1/2" NC	12
33	94-8664	Pivot Retainer Washer	4
34	94-8650	Bushing - flanged - Nylon	14
35	94-8683	Breakaway Retainer Collar	2
36	94-8690	Boom Extension Push Out Bracket	2
37	325-18	Hex hd cap screw, 1/2" NC x 4-1/2"	2
38	94-8675	Extension Spring-Push Out Bracket	2
24	95-2061	Spring Adjuster Screw, 1/2" NC x 2"	2

BOOM LIFT ACTUATOR GROUP

Ref	Part No.	Description	Qty
39	94-8556	Actuator - See Detailed Parts Breakdown	2
40	325-19	Hex hd cap screw, 1/2" NC x 5"	2
41	325-8	Hex hd cap screw, 1/2" NC x 2"	2
42	32146-13	Lock nut, 1/2" NC	6
43	94-8648	Actuator Adjustment Link	2
44	94-8651	Actuator adjuster T	2
45	3218-7	Jam nut, 3/4" NC	2
46	95-2134	Hex hd cap screw, 1/2" NC x 8"	2

PROTOTYPE

WHEEL MOUNT & WHEEL GROUP

Ref	Part No.	Description	Qty
47	94-8652	Castor Fork - Anti-Scalp	2
48	32146-7	Lock Nut, 7/16" NC	2
49	94-8677	Wheel - Anti-Scalp - 5" O.D. x 3/8" I.D.	2
50	323-12	Hex hd cap screw, 3/8" NC x 2-1/2"	2
22	3296-59	Lock nut, 3/8" NC	2
51	94-8653	Castor Mount - Boom Extension -Curved	2
52	94-8655	Castor Mount - Center Section - Straight - Right	1
53	94-8667	Castor Mount - Center Section - Straight c/w Hitch - Left	1
32	3233-6	Carriage bolt, 1/2" NC x 3"	8
42	32146-13	Locknut, 1/2"	12
54	94-8654	Castor Fork - Boom Extension - 4-9/16" shaft	2
55	94-8656	Castor Fork - Center Extension - 8-9/16" shaft	2
56	94-8709	Compression Spring - Center Castor - 1" I.D. x 4"	2
57	3272-23	Cotter Pin - 3/16" x 1-1/2"	4
58	94-8693	Wheel Assembly including: Wheel Rim - 6" x 4" - 6" Centered Hub - 1 of Tire - 15 x 6.00 - 6.00 Turf Rib - 1 of Wheel Bushing - 3/4" Flanged - 2of	4
	94-8694	Wheel Rim - 6" x 4" - 6" Centered Hub c/w Bushing	4
	94-8695	Tire - 15 x 6.00 - 6.00 Turf Rib	4
61	94-8696	Wheel Bushing - 3/4" Flanged	8
62	94-8697	Wheel Bearing Tube - 3/4" O.D. x 6"	4
63	325-36	Hex hd cap screw, 1/2" NC x 7-1/2"	4
64	302-19	Grease zerk - 1/4" NF	10

FOAM MARKER OPTION PARTS

Ref	Part No.	Description	Qty
	94-8772	Hose - Foam Marker Feed - 3/8" x 78" (Not shown)	4
	94-8774	Hose Connector - 3/8" (Not shown)	1
	96609	Hose Clamp - 3/8" (Not shown)	1

INJECTOR-PRO OPTION PARTS

Ref	Part No.	Description	Qty
	42046	1/2 MPT x 1/2 HB - 90	2
	94-8771	Hose - Rinseate Nozzle Feed - 1/2" EVA x 83" (Not shown)	2

PROTOTYPE

MOUNT

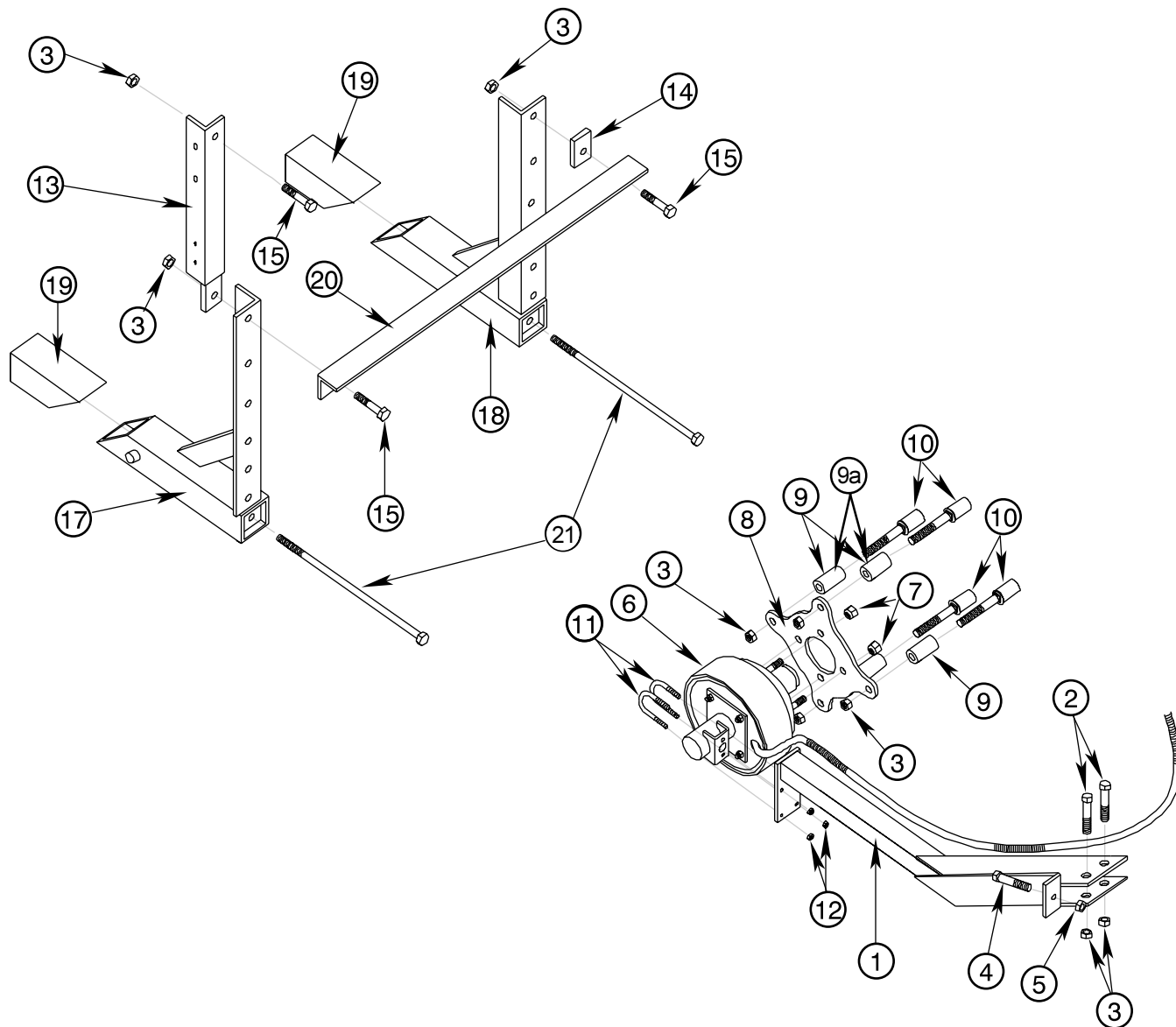

Ref	Part No.	Description	Qty
	94-8704	1100 Mounting Bracket - Right (Not shown)	1
1	94-8705	1100 Mounting Bracket - Left	1
2	3213-9	Hex hd cap screw, 1/2" NC x 3"	4
3	32146-13	Lock Nut, 1/2" NC	15
4	323-7	Hex hd cap screw, 3/8" NC x 1-1/4"	2
5	3296-59	Lock Nut, 3/8" NC	2
6	94-8745	LH Complete Brake Assembly - See Detailed Breakdown	1
	94-8746	RH Complete Brake Assembly - See Detailed Breakdown (Not shown)	1
7	92-0014	Wheel Nut - 1/2" NF	8
8	95-2005	Brake Adapter Mounting Plate	2
9	95-2007	Adapter Spacers - 1/2" I.D. x 2-11/16" *9 is for use on Multi-Pro 1100 Vehicles with Serial No. under 70000	8
9a	95-2448	Adapter Spacers - 1/2" I.D. x 3 7/16" *9a is for use on Multi-Pro 1100 Vehicles with Serial No. 70000 or above	8
	3233-15	Carriage Bolt, 1/2" x 4 1/2" (Not shown - used on right side)	4

Ref	Part No.	Description	Qty
10	95-2006	Retainer Bolt c/w Magnet Mount, 1/2" x 4 1/2" - used on left side	4
11	94-8671	U-Bolt, 1 3/4 I.D. x 3/8" NF x 3-1/2"	4
12	3296-6	Lock Nut, 3/8" NF	4
13	94-8672	Flow Monitor Mount Extender Bracket - used on INJECTOR-PRO	1
14	95-2009	Flow Monitor Mount Spacer - 2" x 1-1/2" x 3/16"	1
15	325-5	Hex hd cap screw, 1/2" NC x 1-1/4"	1
17	42217	Boom Mount Assembly - Left	1
18	42222	Boom Mount Assembly - Right	1
19	42223	Tube Wedge Assembly	2
20	42225	Cross Support Angle	1
21	42199	Hex hd cap screw, 1/2" NC x 18"	2

NOTES:

PROTOTYPE

DRIFT SEAL RETAINER, DRIFT SEAL AND TRIM GROUP

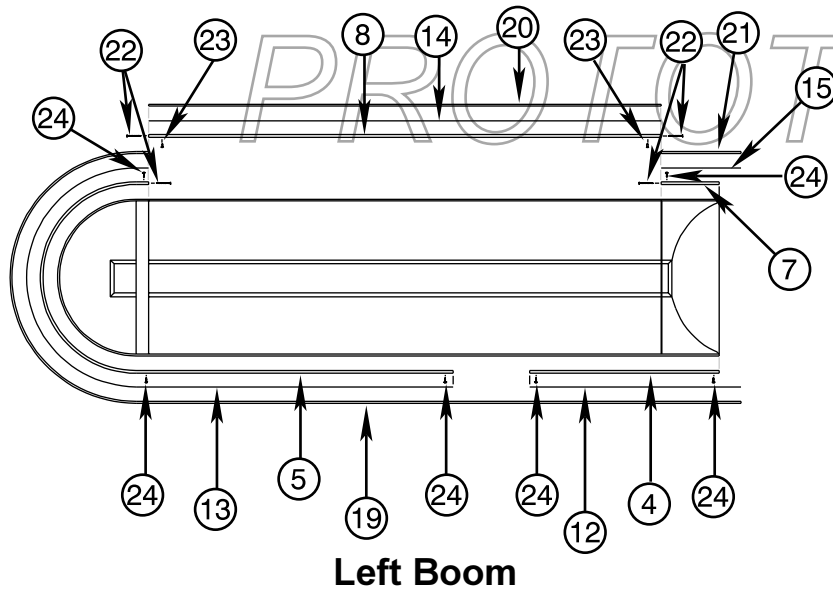
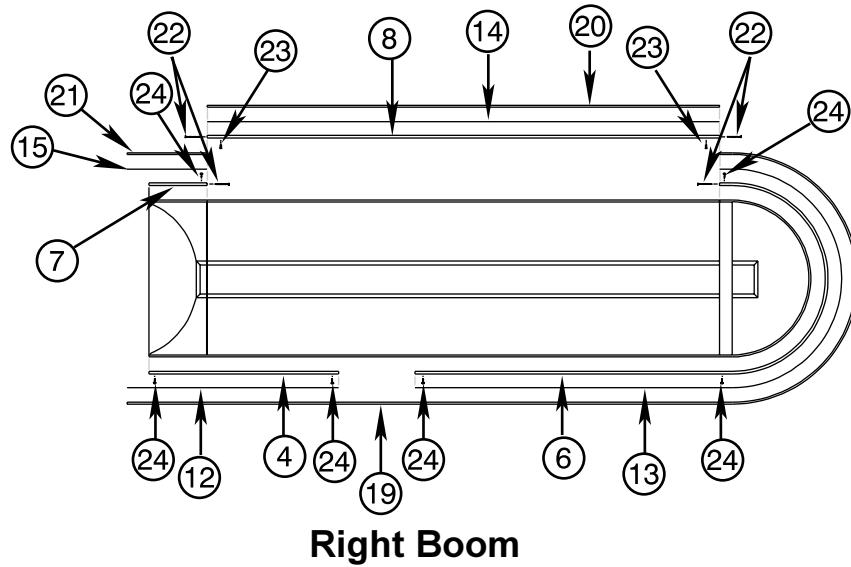
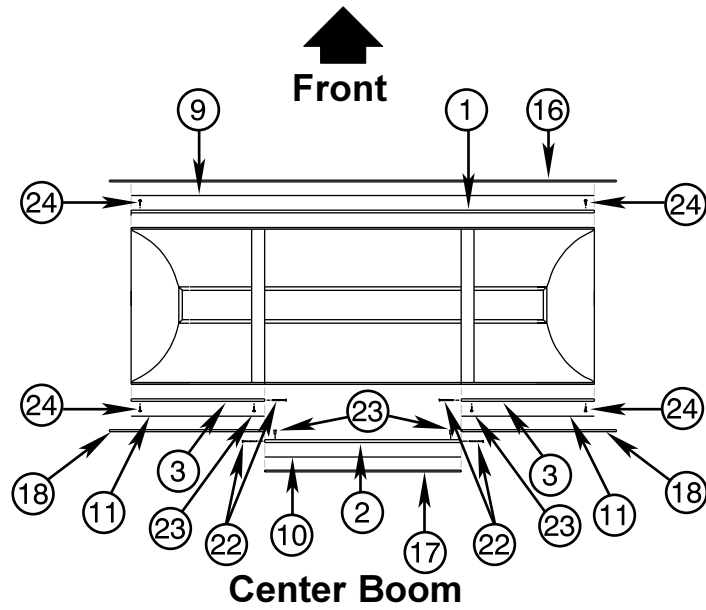

DRIFT SEAL RETAINER, DRIFT SEAL AND TRIM GROUP

Ref	Part No.	Description	Qty
1	95-2001	Drift Seal Retainer - Center Boom Front - 64-1/4"	1
2	95-2002	Drift Seal Retainer - Center Boom Hood - 30-3/8"	1
3	95-2003	Drift Seal Retainer - Center Boom Rear - 16-1/2"	2
4	94-8797	Drift Seal Retainer - Boom Extension - Rear Inner - 26"	2
5	94-8798	Drift Seal Retainer - Boom Extension - Rear Outer - Left - 73-3/4"	1
6	95-2131	Drift Seal Retainer - Boom Extension - Rear Outer - Right - 73-3/4"	1
7	95-2000	Drift Seal Retainer - Boom Extension - Front - 5-7/16"	2
8	94-8799	Drift Seal Retainer - Boom Extension - Hood - 65-9/16"	2
9	94-8768	Red Vinyl Insert - Center Boom - Front - 64-1/4"	1
10	94-8769	Red Vinyl Insert - Center Boom - Hood - 30-3/8"	1
11	94-8770	Red Vinyl Insert - Center Boom - Rear - 16-1/2"	2
12	94-8670	Red Vinyl Insert - Boom Extension - Rear Inner - 26"	2
13	94-8765	Red Vinyl Insert - Boom Extension - Rear Outer - 74-1/8"	2
14	94-8766	Red Vinyl Insert - Boom Extension - Hood - 65-9/16"	2
15	94-8767	Red Vinyl Insert - Boom Extension - Front - 5-7/16"	2
16	94-8660	Drift Seal - Center Boom - Front - 68"	1
17	94-8661	Drift Seal - Center Boom - Hood - 30-3/8"	1
18	94-8662	Drift Seal - Center Boom - Rear - 19"	2
19	94-8657	Drift Seal - Boom Extension - Rear - 113"	2
20	94-8658	Drift Seal - Boom Extension - Hood - 65-1/2"	2
21	94-8659	Drift Seal - Boom Extension - Front - 7-1/2"	2
22	94-8666	#10 x 2" Drift Seal Retainer Screw	12
23	3261-20	Rivet - 3/16" x 3/16" - 1/4" GR Steel	25
24	94-8663	Screw #10 x 3/4" Self Drilling	60

PROTOTYPE

ELECTRIC BRAKE

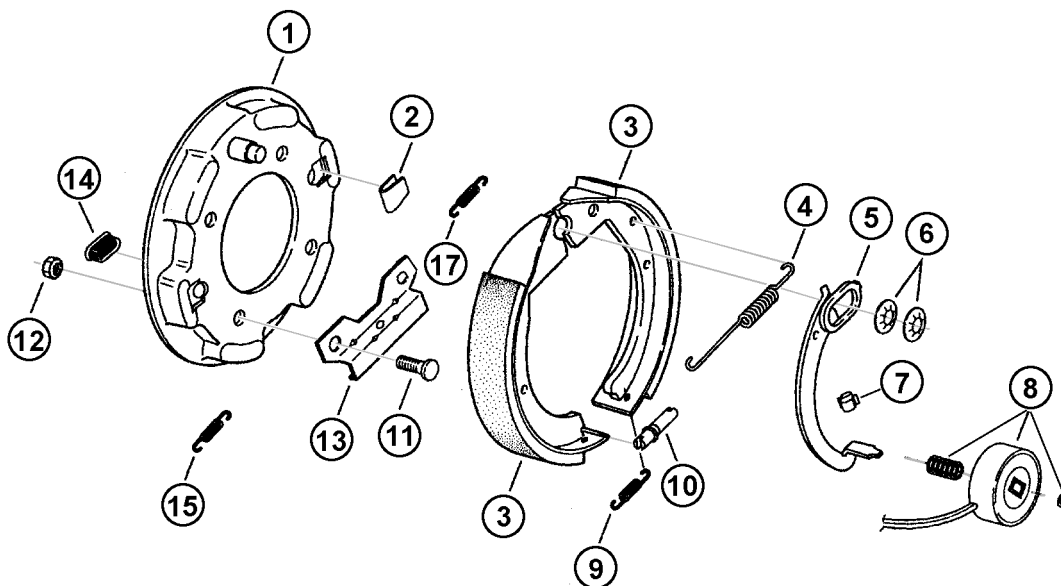

Ref	Part No.	Description	Qty
	94-8745	LH Complete Brake Assembly	1
	94-8746	RH Complete Brake Assembly	1
1	94-8747	Backing Plate Assembly	1
2	94-8748	Shoe Hold Down Spring	2
3	94-8749	Shoe & Lining Kit containing 1 #40-125 Primary S&L 1 #40-49 Secondary S&L	1
4	94-8750	Retractor Spring	1
5	94-8751	LH Actuating Lever Arm	1
	94-8752	RH Actuating Lever Arm (not shown)	1
6	94-8753	Anchor Post Clip	2
7	94-8754	Wire Clip	1
8	94-8755	Magnet Kit containing: 1 Magnet 1 Magnet Clip 1 Magnet Spring	1
9	94-8756	Adjusting Screw Spring	1
10	94-8757	Adjusting Screw	1
11	94-8758	Brake Mounting Bolt	4
12	94-8759	Brake Mounting Nut	4
13	94-8760	Stabilizer Bracket	1
14	94-8761	Plug	1
15	94-8762	Shoe Centering Spring	2

HUB AND SPINDLE GROUP

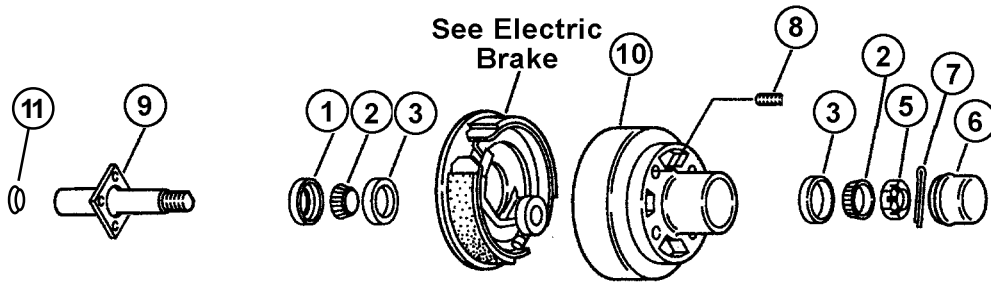

Ref	Part No.	Description	Qty
1	94-8734	Grease Seal	
2	94-8735	Inner / Outer Bearing Cone	B1
3	94-8736	Inner / Outer Bearing Cup	2
5	94-8739	Spindle Nut	2
6	94-8740	Grease Cap	1
7	94-8741	Cotter Pin	1
8	94-8743	Wheel Stud, 1/2" - 20	1
9	94-8742	Brake Spindle c/w Flange	4
10	94-8744	Hub & Drum	1
11	95-2449	Brake End Cap / Plug	1

PROTOTYPE

ELECTRIC BRAKE CONTROLLER

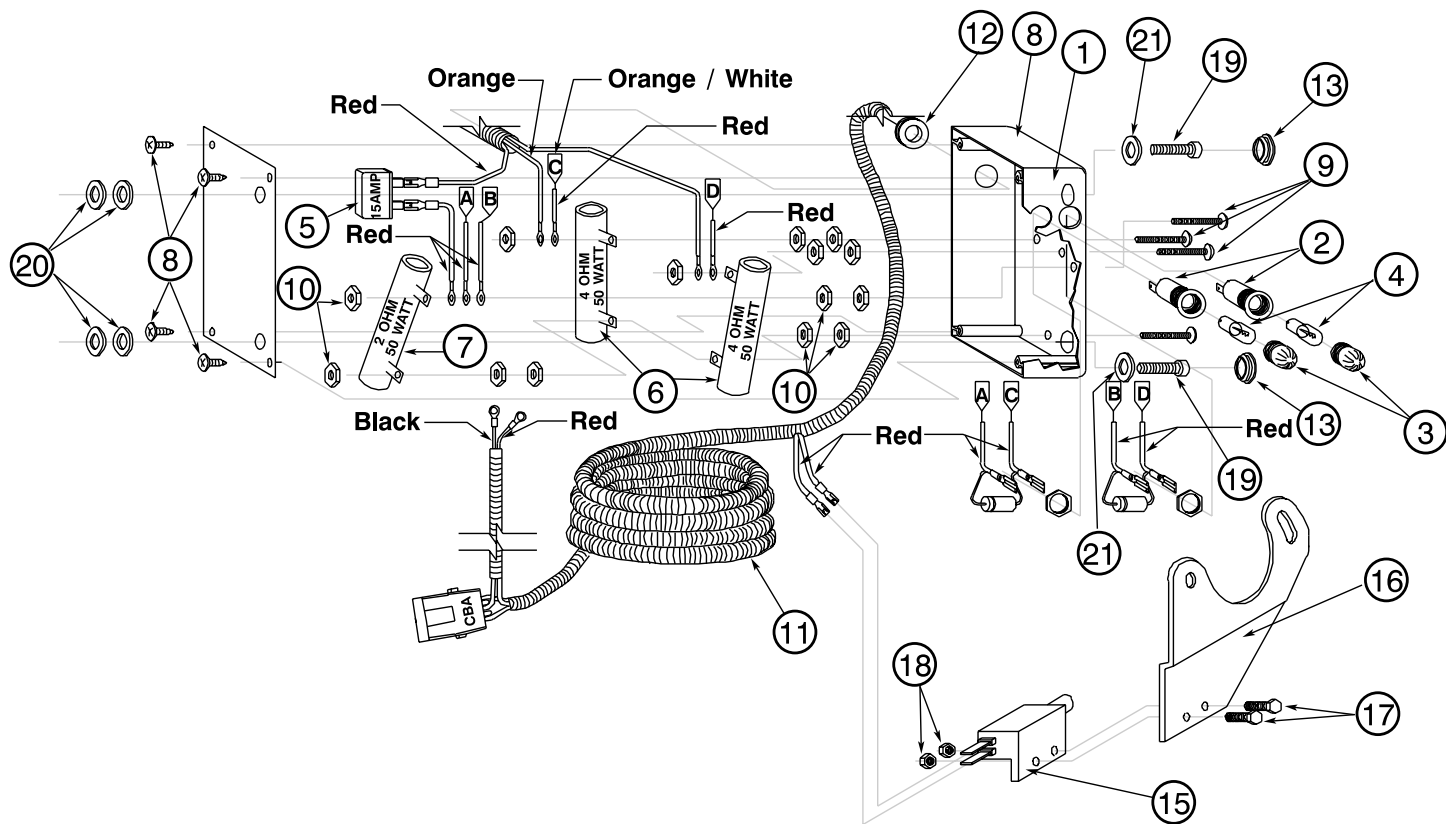

Ref	Part No.	Description	Qty
	95-2010	Brake Controller Assembly	1
1	94-8727	Decal - Brake Controller	1
2	95-2117	Light Socket	2
3	95-2118	Lens - Red	2
4	95-2119	Light Bulb - #45 3.2v	2
5	94-8729	15 Amp Breaker - self resetting	1
6	94-8730	Resistor - 4 Ohm 50w	2
7	95-2120	Resistor - 2 Ohm 50w	1
8	94-8731	Enclosure Box	1
9	32105-17	Pan Machine Screw, 6-32 x 1-1/4 - Philips drive	3
10	3217-29	Nut, 6-32	9
11	94-8733	Wire Harness	1
12	95-2001	Grommet - 3/8" I.D. to fit 1/8" thk panel	1
13	94-8732	Plug - to fit 3/4" I.D. hole in 1/8" thk panel	2
14	40764	Grommet 2" - Front of Steering Console (Not shown)	1
15	92035	Brake Switch	1
16	95-2008	Brake Switch Mounting Bracket	1
17	95-2044	Hex hd cap screw, 3/16" NC x 3/4"	2
18	9157404	Locknut, #10 NC	2
19	95-2133	Socket hd cap screw, 1/4" x 3/4"	2
20	3256-2	Flat Washer, 1/4"	2
21	95-2132	Spring Washer, 1/4"	2

ELECTRIC ACTUATOR

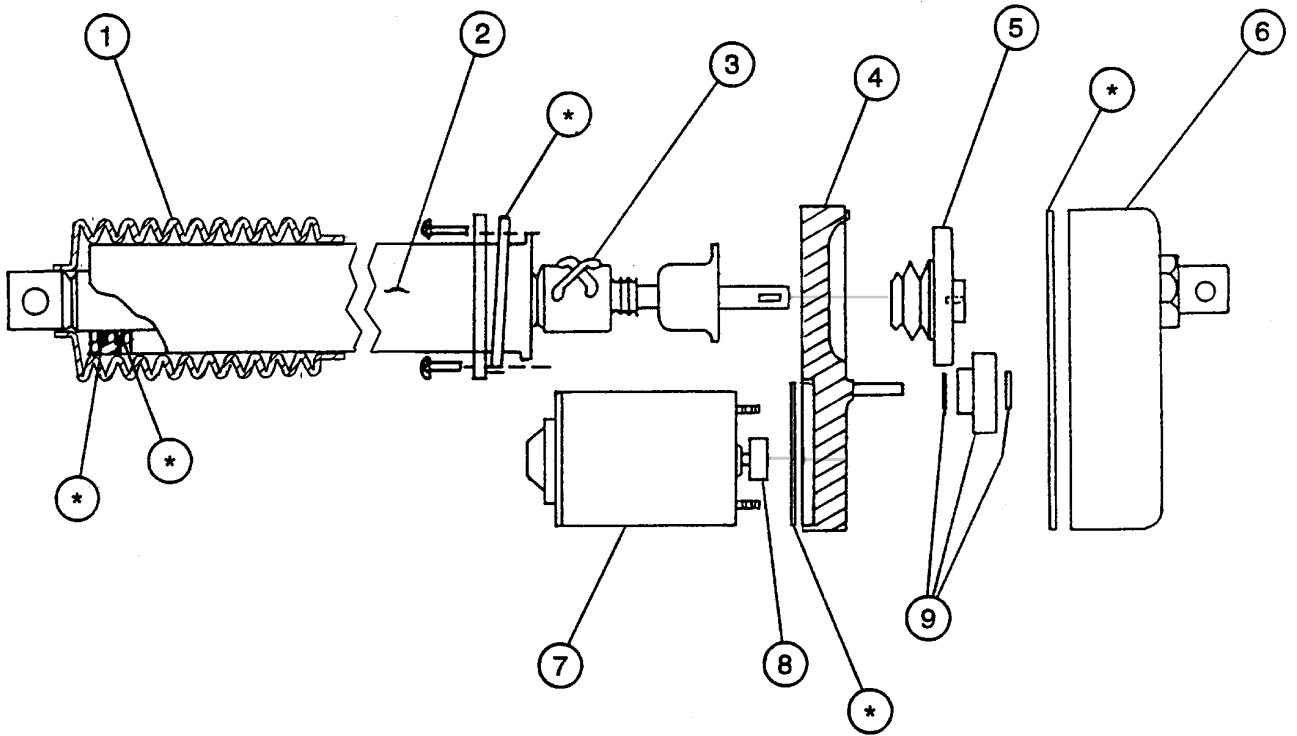

Ref	Part No.	Description	Qty
	94-8556	Actuator - Complete Assembly	1
1	94-8796	Boot Kit (Includes clamps)	1
2	94-8676	Cover Tube	1
3	94-8665	Drive Screw Assembly	1
4	94-8776	Front Housing	1
5	42847	Clutch Assembly	1
6	92-3851	Rear Housing	1
7	94-8794	Motor	1
8	42852	Motor Pinion Gear	1
9	94-8795	Intermediate Gear	1
*	42851	Sealing Kit	AR

PROTOTYPE

ACTUATOR WIRING HARNESS

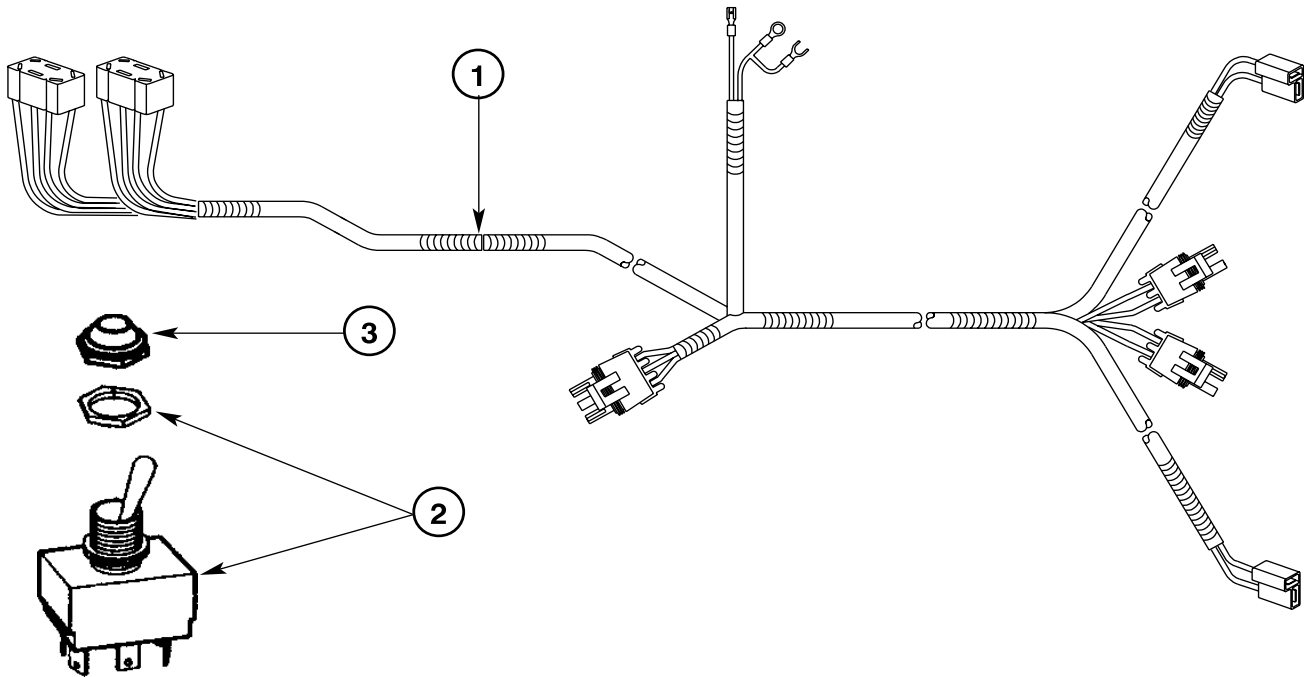

Ref	Part No.	Description	Qty
1	94-8559	Wiring Harness	1
2	30954	Toggle Switch c/w Nut	2
3	30955	Rubber Boot	2
4	42765	Fuse - 30 Amp (Not Shown)	1

PROTOTYPE

PLUMBING GROUP

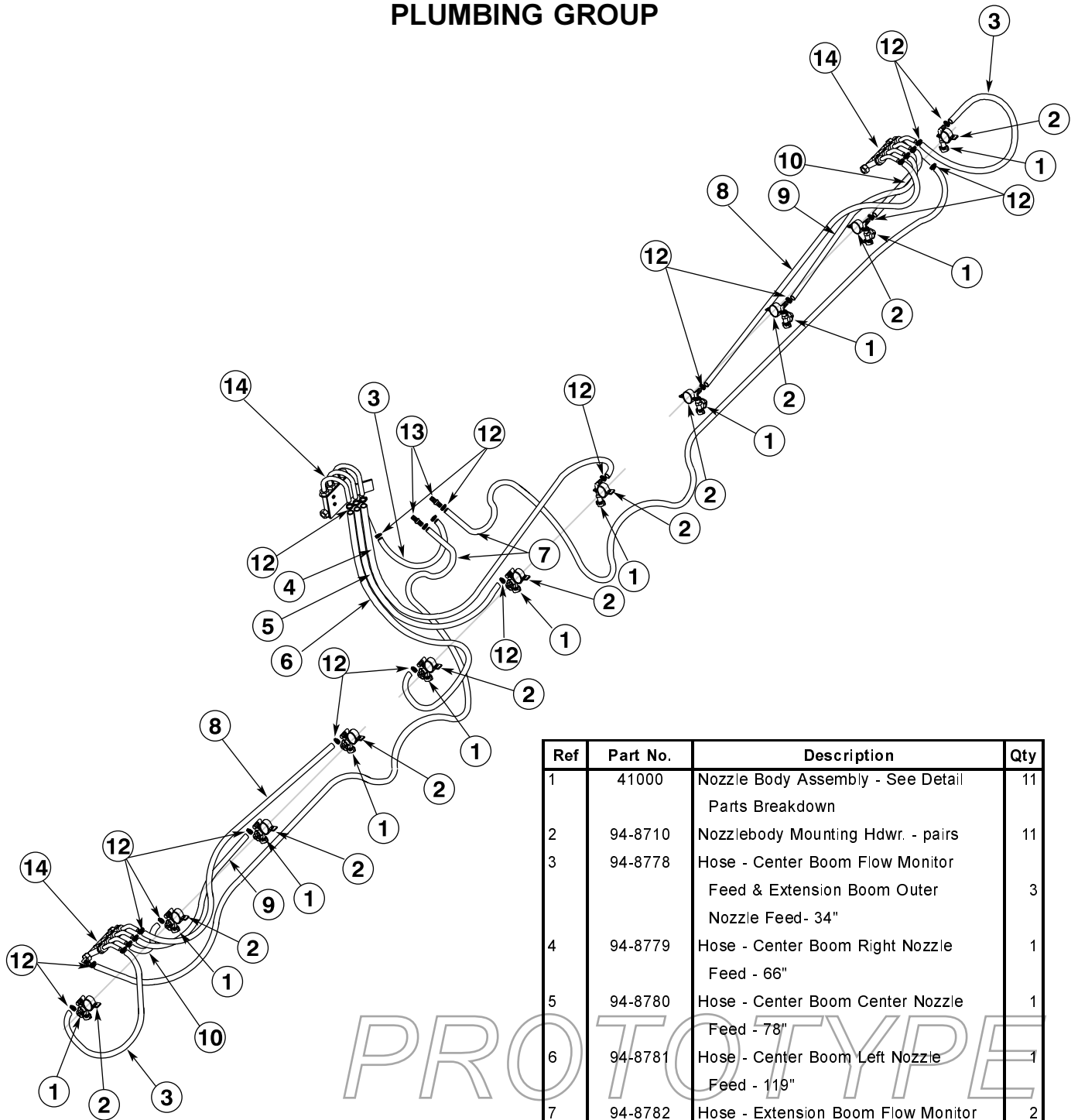

Ref	Part No.	Description	Qty
1	41000	Nozzle Body Assembly - See Detail Parts Breakdown	11
2	94-8710	Nozzlebody Mounting Hdw. - pairs	11
3	94-8778	Hose - Center Boom Flow Monitor Feed & Extension Boom Outer Nozzle Feed - 34"	3
4	94-8779	Hose - Center Boom Right Nozzle Feed - 66"	1
5	94-8780	Hose - Center Boom Center Nozzle Feed - 78"	1
6	94-8781	Hose - Center Boom Left Nozzle Feed - 119"	1
7	94-8782	Hose - Extension Boom Flow Monitor Feed - 174"	2
8	94-8783	Hose - Extension Boom Inner Nozzle Feed - 59"	2
9	94-8784	Hose - Extension Boom Second from Inner Nozzle Feed - 41"	2
10	94-8785	Hose - Extension Boom Second from Outer Nozzle Feed - 23"	2
12	2412-36	Hose Clamps	27
13	95-2073	Hose Connector - 3/4"	2
14		Flow Monitor Assy - See Detail Parts Breakdown	

PLUMBING GROUP

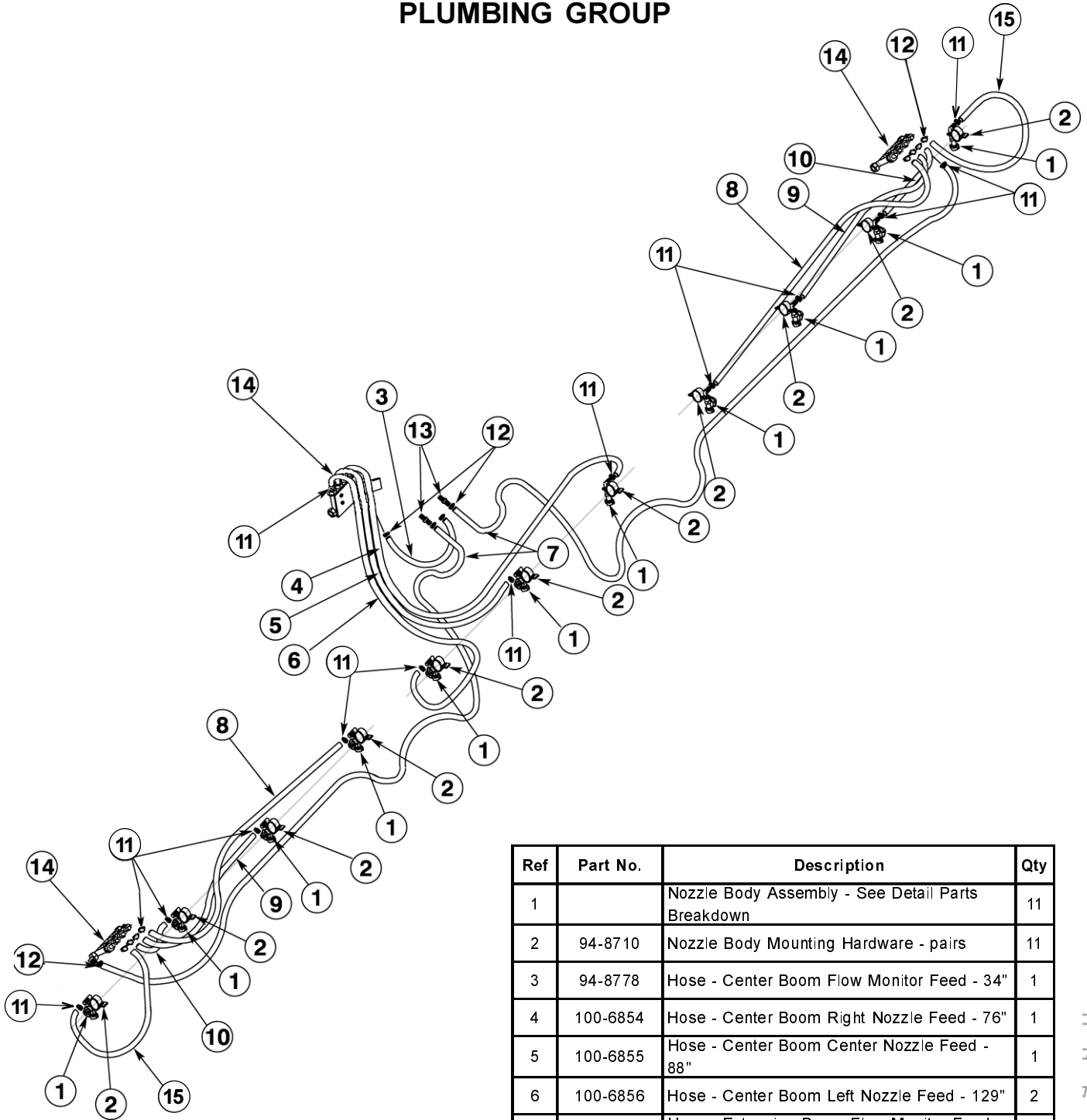

Ref	Part No.	Description	Qty
1		Nozzle Body Assembly - See Detail Parts Breakdown	11
2	94-8710	Nozzle Body Mounting Hardware - pairs	11
3	94-8778	Hose - Center Boom Flow Monitor Feed - 34"	1
4	100-6854	Hose - Center Boom Right Nozzle Feed - 76"	1
5	100-6855	Hose - Center Boom Center Nozzle Feed - 88"	1
6	100-6856	Hose - Center Boom Left Nozzle Feed - 129"	2
7	94-8782	Hose - Extension Boom Flow Monitor Feed - 174"	2
8	100-6857	Hose - Extension Boom Inner Nozzle Feed - 69 1/2"	2
9	100-6858	Hose - Extension Boom Second from Inner Nozzle Feed - 49 1/2"	2
10	100-6859	Hose - Extension Boom Second from Outer Nozzle Feed - 31"	2
11	96609	Clamp - Hose, 1/2"	22
12	2412-36	Clamp - Hose, 3/4"	5
13	95-2073	Hose Connector - 3/4"	2
14		Flow Monitor Assy - See Detail Parts Breakdown	
15	100-6860	Hose - Extension Boom Outer Nozzle Feed - 42"	2

NOZZLEBODY ASSEMBLY

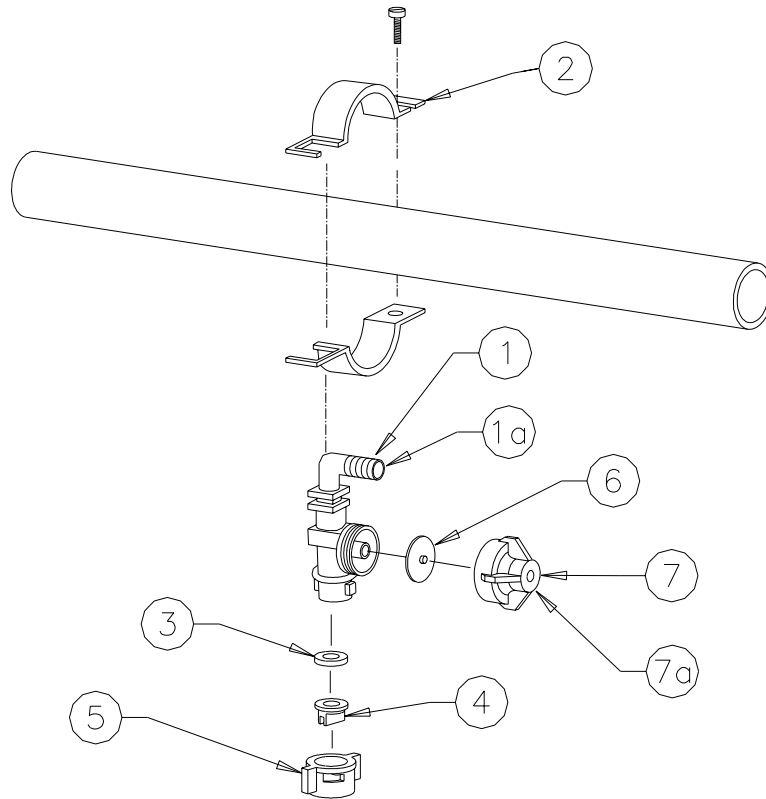

Ref	Part No.	Description	Qty
1	41000	Nozzlebody - L Type Assy Includes: Nozzlebody - 1 of Diaphragm - 1 of Diaphragm Cap (10 p.s.i.) - 1 of	1
1a	95-2452	Nozzlebody - L Type Assy Includes: Nozzlebody - 1 of Diaphragm - 1 of Diaphragm Cap (20 p.s.i.) - 1 of - Used on Enclosed Booms with Serial No. above 70130	1
2	94-8710	Nozzlebody Mounting Hardware - pairs	1
3	40998	Gasket - Nozzle	1
4	94-8719	Spray Nozzle - Teejet XR11015SS	1
4	94-8718	Spray Nozzle - Teejet XR11010SS (Standard with Boom)	1
4	94-8717	Spray Nozzle - Teejet XR11008VS	1
4	94-8716	Spray Nozzle - Teejet XR11006VS	1
4	94-8715	Spray Nozzle - Teejet XR11005VS	1
4	94-8714	Spray Nozzle - Teejet XR11004VS	1
5	94-8720	Spray Nozzle Retainer Cap	1
6	41003	Diaphragm	1
7	95-2451	Diaphragm Cap - 10 p.s.i.	1
7a	95-2450	Diaphragm Cap - 20 p.s.i. - Used on Enclosed Booms with Serial No. above 70130	1

PROTOTYPE

NOZZLEBODY ASSEMBLY

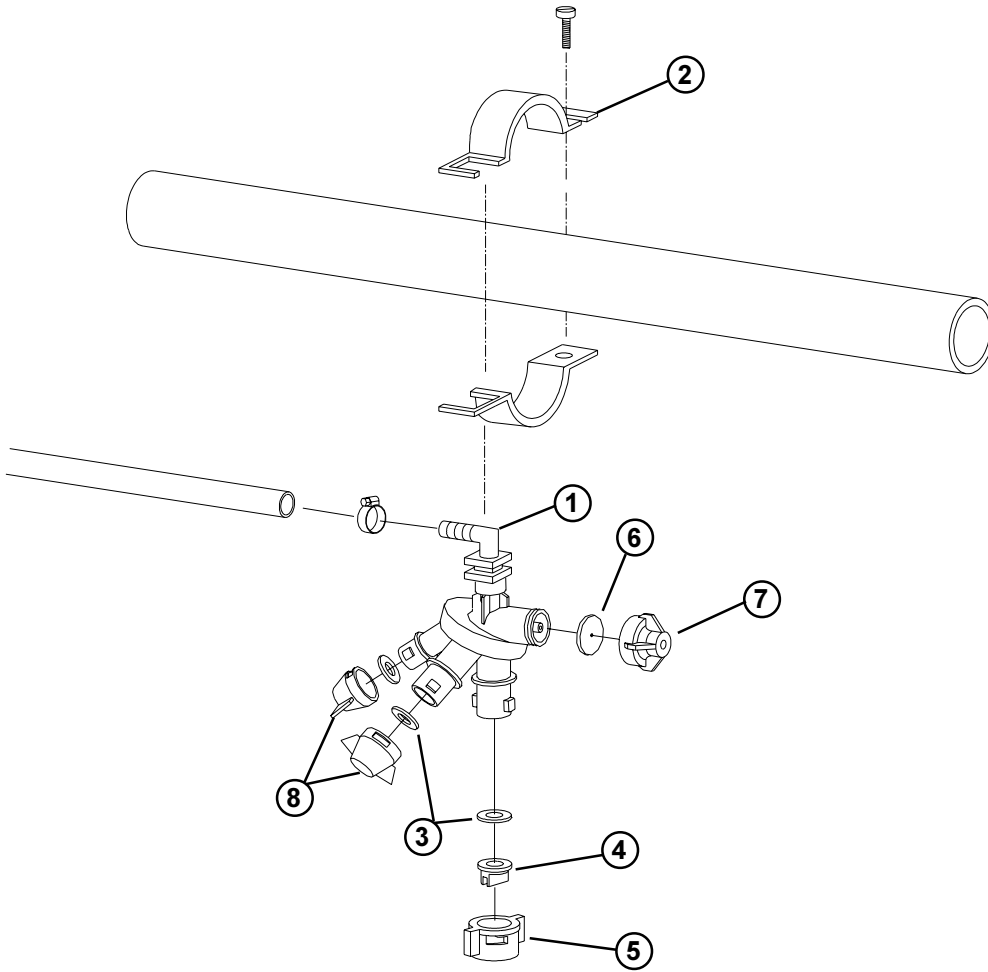

Ref	Part No.	Description	Qty
1	100-6853	Nozzlebody - Triple Type Assy Includes: Nozzlebody - 1 of Diaphragm - 1 of Diaphragm Cap (10 p.s.i.) - 1 of	1
2	94-8710	Nozzlebody Mounting Hardware - pairs	1
3	40998	Gasket - Nozzle	3
4	94-8719	Spray Nozzle - Teejet XR11015SS	1
4	94-8718	Spray Nozzle - Teejet XR11010SS (Standard with Boom)	1
4	94-8717	Spray Nozzle - Teejet XR11008VS	1
4	94-8716	Spray Nozzle - Teejet XR11006VS	1
4	94-8715	Spray Nozzle - Teejet XR11005VS	1
4	94-8714	Spray Nozzle - Teejet XR11004VS	1
5	94-8720	Spray Nozzle Retainer Cap	1
6	41003	Diaphragm	1
7	95-2451	Diaphragm Cap - 10 p.s.i.	1
8	95-9187	Spray Nozzle Retainer Cap - Blank	2

FLOW MONITOR

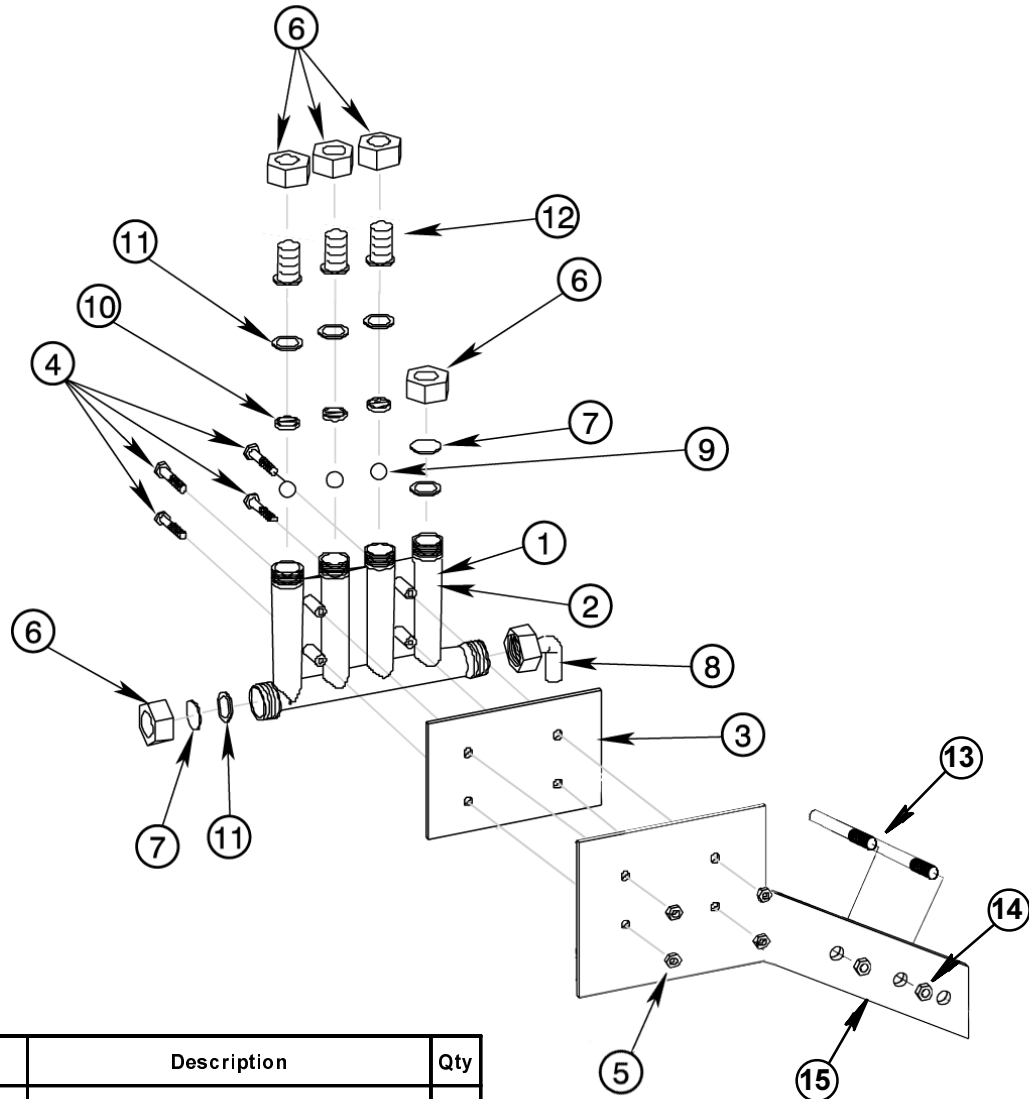

Ref	Part No.	Description	Qty
1	94-8721	Flow Monitor Assembly	3
2	95-2032	Manifold - Flow Monitor	3
3	94-8691	Plate - Backing	3
4	321-11	Screw - HH, 1/4" UNC x 2" YZ	4
5	32146-17	Nut - Lock, 1/4" UNC YZ	4
6	94-8722	Swivel Nut	5
7	94-8692	Blank Disk	2
8	94-8723	Elbow - 3/4" FPT - 3/4" HB	1
9	94-8724	Flow Indicator Ball - Steel	4
10	94-8725	Flow Indicator Ball Retainer	4
11	94-8726	Rubber Washer	5
12	100-6852	Swivel Barb	4
13		Clamp - Hose Retainer	1
14		Nut - Lock, 3/8" UNC	2
15		Flow Monitor Mount - Center Boom	1

PROTOTYPE

NOTES:

PROTOTYPE

NOTES:

PROTOTYPE



Helping you put quality into play.®

PROTOTYPE