



Electric Starter Kit

ProLine Mid–Size Mower

Part No. 104–8580

Parts Catalog

Ordering Replacement Parts

To order replacement parts, please supply: the part number, the quantity, and the description of each part desired.

Understanding Reference Numbers

Each identified part in an illustration has a reference number. The reference number for a part also appears in the parts list, along with other information about the part.

This catalog uses two special reference number formats, one to indicate parts in a service assembly and another to indicate the quantity of a given part in an illustration.

Service Assembly Reference Numbers

Parts in service assemblies have reference numbers in the form **a:b**. The **a** represents the reference number of the entire service assembly and the **b** represents a sequential number unique to each part within the service assembly.

For example, a wheel assembly might be identified by reference number **6**, the tire by **6:1**, the valve by **6:2**, and the wheel by **6:3**. When you order the assembly identified by reference number **6**, you receive all parts identified by reference numbers **6:1**, **6:2**, and **6:3**. However, you may also order any part individually.

Reference numbers of this type appear in illustrations and in part lists.

Reference Numbers Indicating Quantity

In an illustration, if a reference number indicates more than one part, the reference number has the form **nX y**. The **n** represents the quantity of the part, the **X** is the multiplication symbol, and the **y** represents the reference number.

For example, in an illustration, the reference number **2X 37** means that two of the parts identified by reference number **37** are indicated.

Contents

Description	Page	Description	Page
Starter and Solenoid Assembly	3	Battery Assembly	5
Ignition Switch Assembly	4		

Part Description Abbreviations

Part descriptions in this catalog may include the following abbreviations.

Abbreviation	Meaning	Abbreviation	Meaning
AR	as required	HYD	hydraulic
ASM	assembly	INC	incorporated
CARR	carriage	LH	left hand
DEG	degrees	NI	nylon insert
FH	flat head	PPH	Phillips pan head
GA	gauge	PTH	Phillips truss head
HF	hex flange	PTO	power take off
HH	hex head	RH	right hand
HHF	hex head flange	SFH	slotted fillister head
HLH	hex lag head	SHH	slotted hex head
HJ	hex jam	SQH	square head
HOC	height-of-cut	SHWH	slotted hex washer head
HS	hex socket	SPH	slotted pan head
HSBH	hex socket button head	SRH	slotted round head
HSFH	hex socket flat head	STD	standard
HSH	hex socket head	TAP	self tapping
HWH	hex washer head	TTH	Torx truss head
HWHTF	hex washer head thread forming	WH	wing head

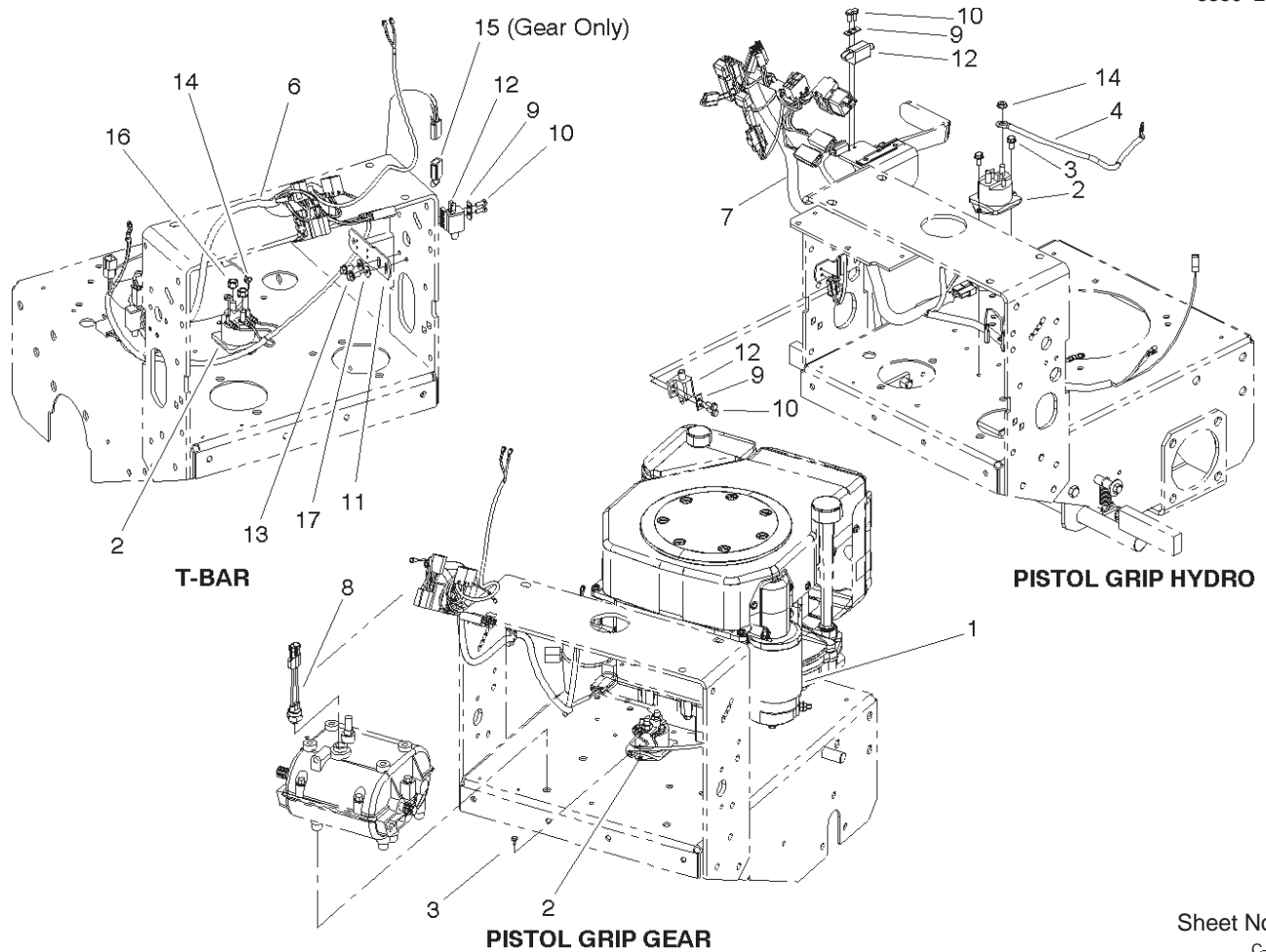

Sheet No.: 1
C-3020

Starter and Solenoid Assembly

Ref. No.	Part No.	Qty.	Description
1	77-5070	1	Starter ASM
2	28-4210	1	Solenoid
3	12-3270	2	Screw
4	28-3891	1	Wire-Solenoid/Starter
6	105-2687	1	Harness-Wire (T-Bar)
7	106-0875	1	Harness-Wire
8	72-4310	1	Switch-Ball
9	82-4570	2	Plate-Switch
10	32144-1	4	Screw-Taptite
11	82-4580-03	2	Bracket-Neutral
12	65-7410	2	Switch-Pole, Single
13	32144-4	4	Screw-HWH
14	32149-8	2	Nut-Keps
15	105-2688	2	Wire-Jumper ASM
16	32149-1	2	Nut
17	3256-1	4	Washer-Flat

Ref. No.	Part No.	Qty.	Description

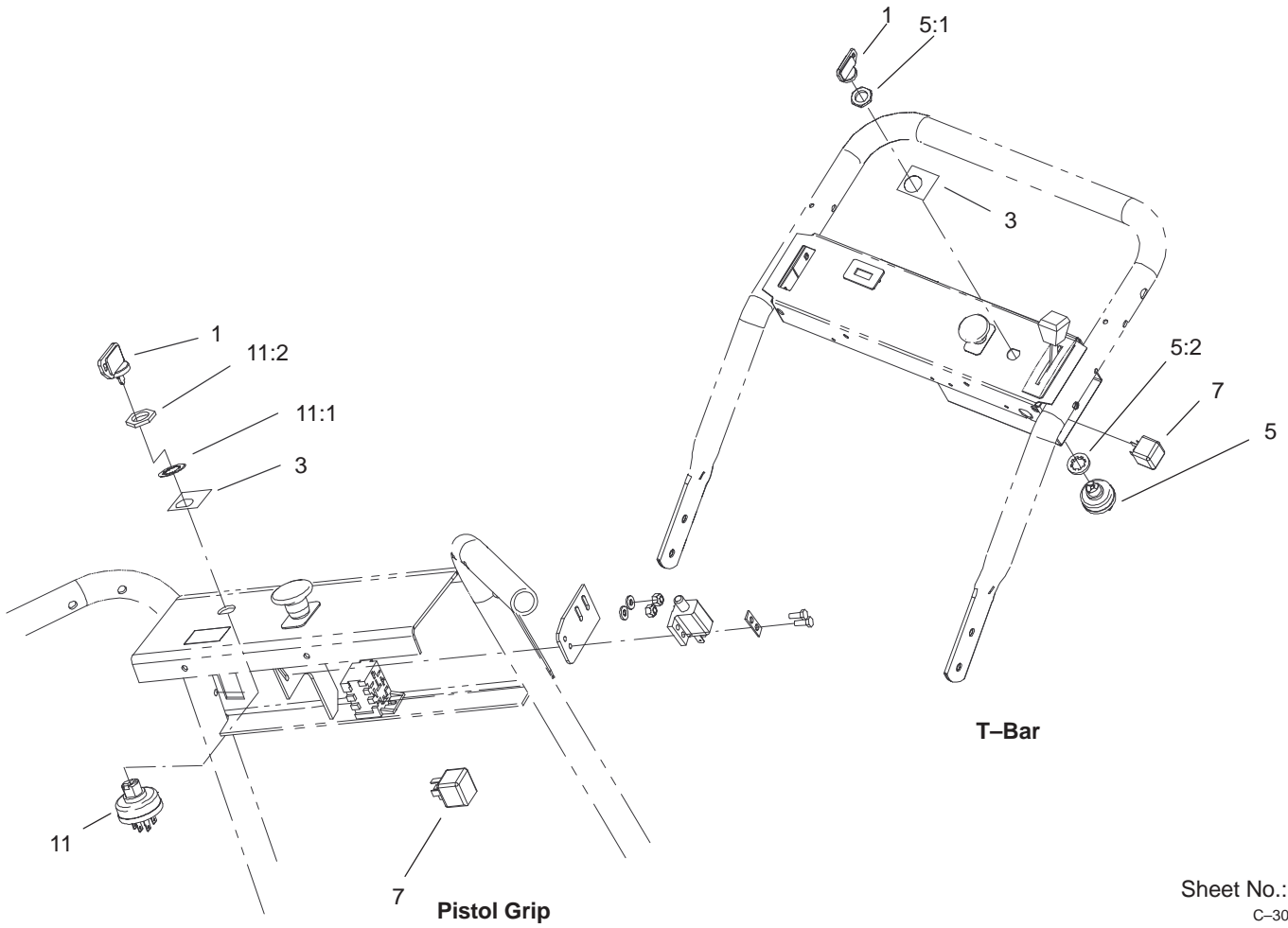

Sheet No.: 2
C-3021

Ignition Switch Assembly

Ref. No.	Part No.	Qty.	Description
1	63-8360	1	Key-Ignition
3	106-0909	1	Decal-Electric Start
5	116338	1	Key Switch ASM
5:1	101884	1	Nut
5:2	9201604	1	Washer-Lock, Internal
7	98-7249	1	Relay
11	88-9830	1	Key Switch ASM
11:1	3254-5	1	Washer-Tooth
11:2	218-461	1	Nut-HH

Ref. No.	Part No.	Qty.	Description

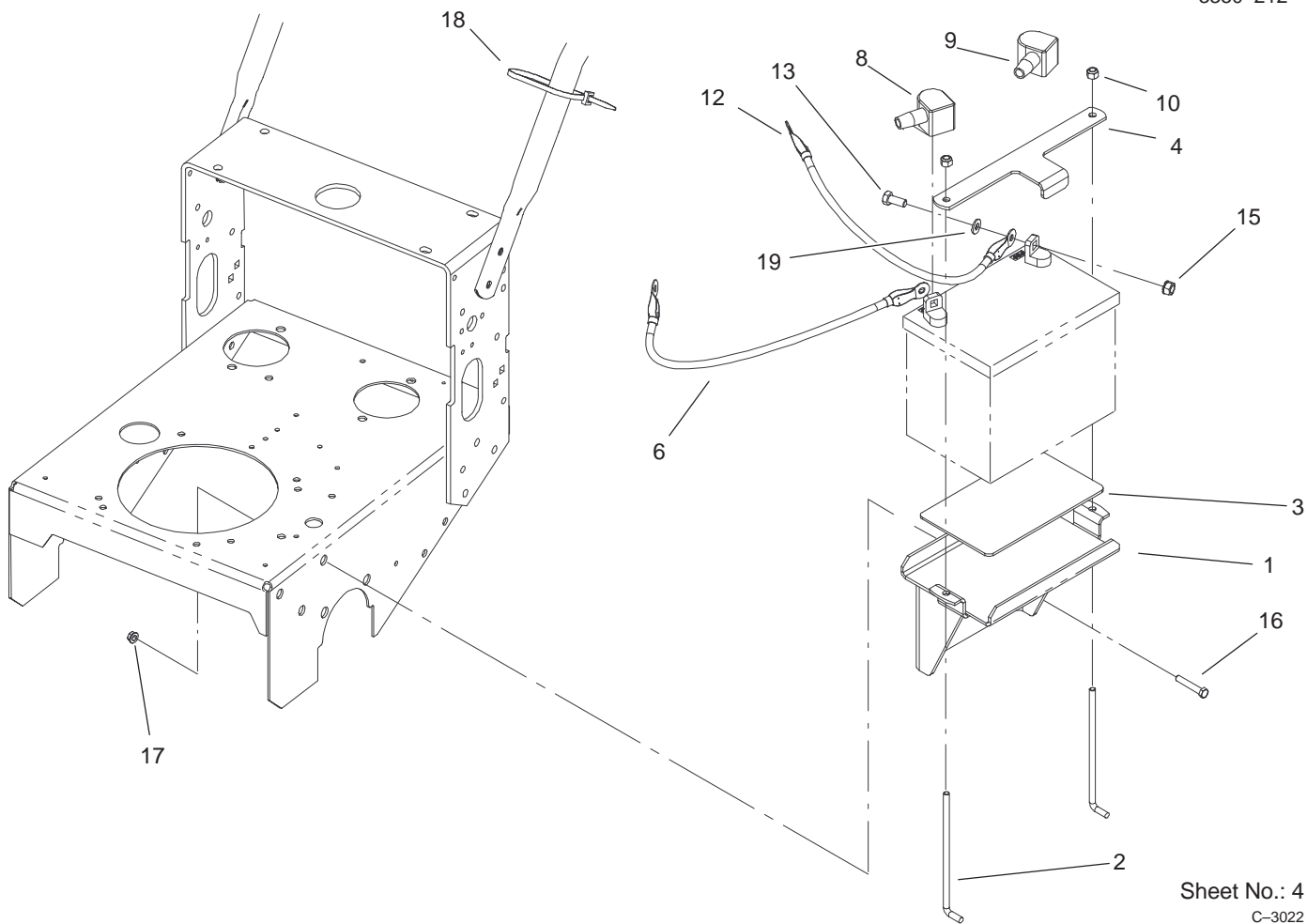

Sheet No.: 4
C-3022

Battery Assembly

Ref. No.	Part No.	Qty.	Description
1	105-0804-01	1	Battery Plate ASM
2	104-8567	2	Holddown-Battery
3	62-4300	2	Anti-Skid Pad
4	104-8568-03	1	Plate-Hold Down, Battery
6	105-0836	1	Cable-Battery, Black
8	77-0980	1	Boot-Terminal, Black
9	77-0981	1	Boot-Terminal, Red
10	3296-42	2	Nut-Lock, NI
12	100-6457	1	Cable-Battery, Red
13	322-3	2	Screw-HH
15	32149-1	2	Nut
16	3234-22	2	Screw-HHF
17	32128-23	2	Nut-HF
18	3290-378	4	Tie-Cable
19	3256-2	2	Washer-Flat

Ref. No.	Part No.	Qty.	Description

Maintenance Record

Date								

Maintenance Record

Date								

