



7-Blade Reel Mower Reelmaster[®] 5500-D and 6000-D Series

Model No. 03861 - 240000001 and up.

Parts Catalog

Ordering Replacement Parts

To order replacement parts, please supply the part number, the quantity, and the description of each part desired.

Understanding Reference Numbers

Each Identified part in an illustration has a reference number. The reference number for a part also appears in the parts list, along with other information about the part.

This catalog uses two special reference number formats, one to indicate parts in a service assembly and another to indicate the quantity of a given part in an illustration.

Service Assembly Reference Numbers

Parts in service assemblies have reference numbers in the form a:b. The a represents the reference number of the entire service assembly and the b represents a sequential number unique to each part within the service assembly.

For example, a wheel assembly might be identified by reference number 6, the tire by 6:1, the valve by 6:2, and the wheel by 6:3. When you order the assembly identified by reference number 6, you receive all parts identified by reference numbers 6:1, 6:2, and 6:3. However, you may also order any part individually. Reference numbers of this type appear in illustrations and in part lists.

Reference Numbers Indicating Quantity

In an illustration, if a reference number indicates more than one part, the reference number has the form nX y. The n represents the quantity of the part, the X is the multiplication symbol, and the y represents the reference number.

For example, in an illustration, the reference number 2X 37 means that two of the parts identified by reference number 37 are indicated.

Part Description Abbreviations

Part descriptions in this catalog may include the following abbreviations.

AR.	as required	HYD.	hydraulic
ASM.	assembly	INC.	incorporated
CARR.	carriage	LH.	left hand
DEG.	degrees	NI.	nylon insert
FH.	flat head	PPH.	phillips pan head
GA.	gauge	PTH.	phillips truss head
HF.	hex flange	PTO.	power take off
HH.	hex head	RH.	right hand
HHF.	hex head flange	SFH.	slotted fillister head
HHFTF.	hex head flange thread forming	SHH.	slotted hex head
HJ.	hex jam	SHWH.	slotted hex washer head
HLH.	hex lag head	SPH.	slotted pan head
HOC.	height-of-cut	SQH.	square head
HS.	hex	SRH.	slotted round head
HSBH.	hex socket button head	STD.	standard
HSFH.	hex socket flat head	TAP.	self tapping
HS.	hex socket head	TTH.	torx truss head
HWH.	hex washer head	WH.	wing head
HWHTF.	hex washer head thread forming		

Footnotes

- ❶ Not illustrated
- ❷ See following pages
- ❸ Not serviced separately

Contents

Description	Page	Description	Page
Reel and Frame Assembly 3	Optional Shoulder Roller Assembly No. 99-8675 (RM6000-D Series) 11
Bed Bar Assembly 5	Roller Kit Assembly No. 106-9606 12
Bedbar Pivot Service Kit Assembly No. 106-9605 6	Gauge Bar, Angle Indicator and Handle Assembly 13
Roller and Carrier Frame Assembly 7		
Full Roller Assembly No. 99-5749 8		
Wiehle Roller Assembly No. 100-9906 9		
Optional Shoulder Roller Assembly No. 100-9911 (RM5500-D Series) 10		

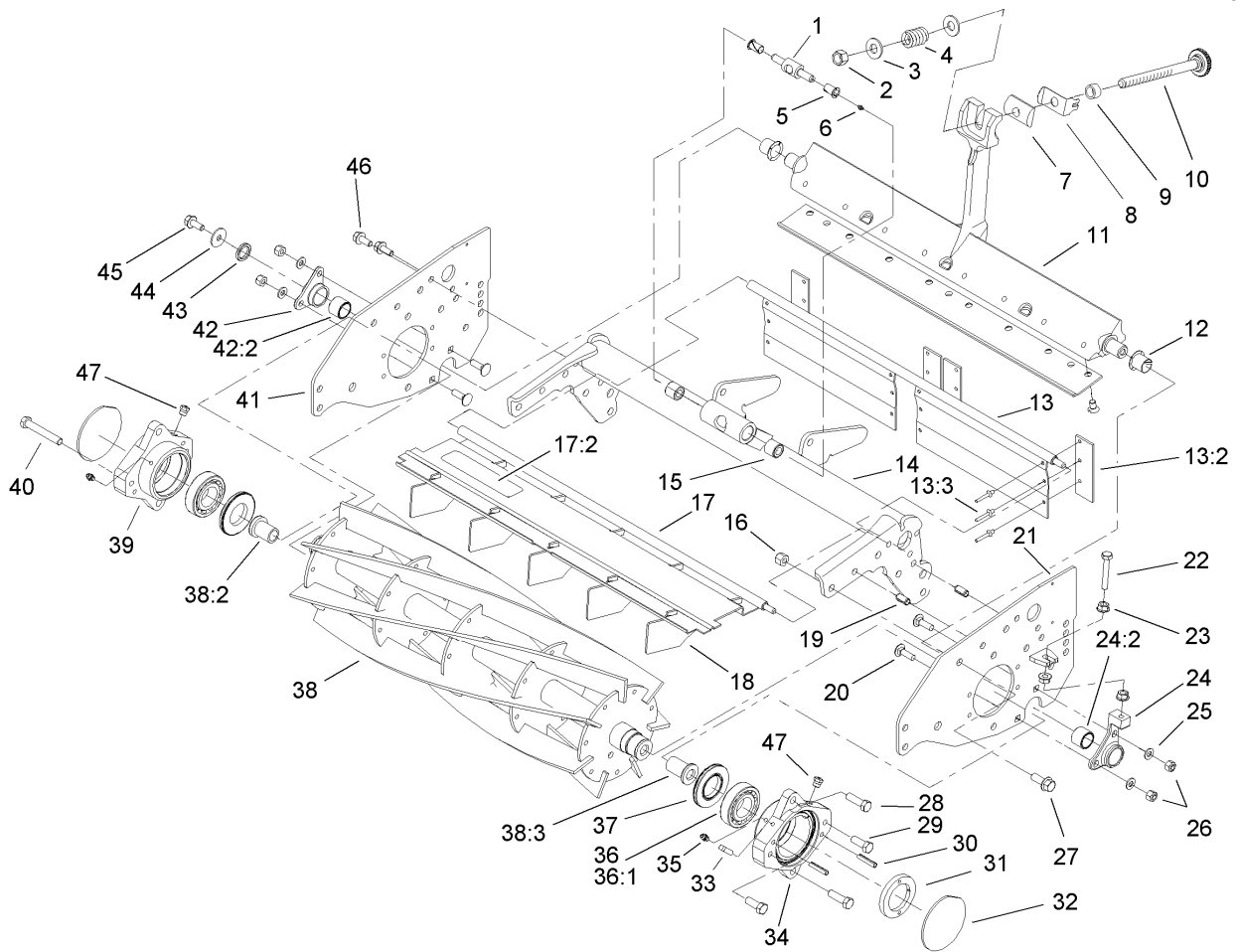

Reel and Frame Assembly

Ref	Part No.	Qty.	Description
1	107-7409	1	Pin-Pivot, Bedbar
2	3296-62	1	Nut-Lock NI
3	29-8910	2	Washer
4	95-0772	1	Spring-Compression
5	52-2890	2	Bushing-Nylon
6	302-18	1	Fitting-Grease
7	93-2892	1	Pivot-Bedbar, Main Adj
8	95-8752	1	Arm-Spring
9	93-2959	1	Spacer-Adjuster
10	106-7536	1	Bedbar Adjuster ASM
11	99-8698-01	1	Bedbar
12	93-7502	2	Bushing-Flanged
13	100-2289	1	Rear Grass Shield ASM
13:2	98-3999	4	Flap-Side
13:3	700382	12	Rivet
14	100-4994-01	1	Frame-Reel
15	62-5510	2	Bushing-Rubber
16	3296-39	12	Nut-Lock, NI
17	100-9900	1	Front Grass Shield ASM
17:2	93-6688	1	Decal-Danger, Europe
17:2	94-4584	1	Decal-Danger, Japan
17:2	67-7960	1	Decal-Danger
18	100-2287	5	Deflector-Shield, Grass
19	32121-36	4	Pin-Spring

Ref	Part No.	Qty.	Description
20	3230-2	4	Bolt-CARR
21	100-2268-01	1	LH Sideplate ASM
22	94-3489	1	Capscrew-HH
23	33004-00	3	Nut-HF
24	100-3381	1	LH Pivot Hub ASM
24:2	93-7501	1	Bushing ASM
25	3256-74	4	Washer-Flat
26	3296-29	4	Nut-Lock, NI
27	3234-11	8	Screw-HHF
28	323-7	4	Screw-HH
29	323-6	2	Screw-HH
30	32121-69	4	Pin-Spring
31	95-2793	1	Nut-Adjustment, Bearing
32	94-2703	1	Plug
33	105-6758	1	Setscrew-SQH
34	105-6755	1	Housing-Bearing, LH
35	302-5	2	Fitting-Grease
36		2	Bearing-Packed, Grease
36:1	93-2489	1	Bearing
37	105-6757	2	Seal-Grease
38	95-2770	1	7 Blade Reel ASM
38:2	94-2732	1	Insert-Threaded, RH
38:3	94-2733	1	Insert-Threaded, LH
39	105-6759	1	Housing-Bearing, RH

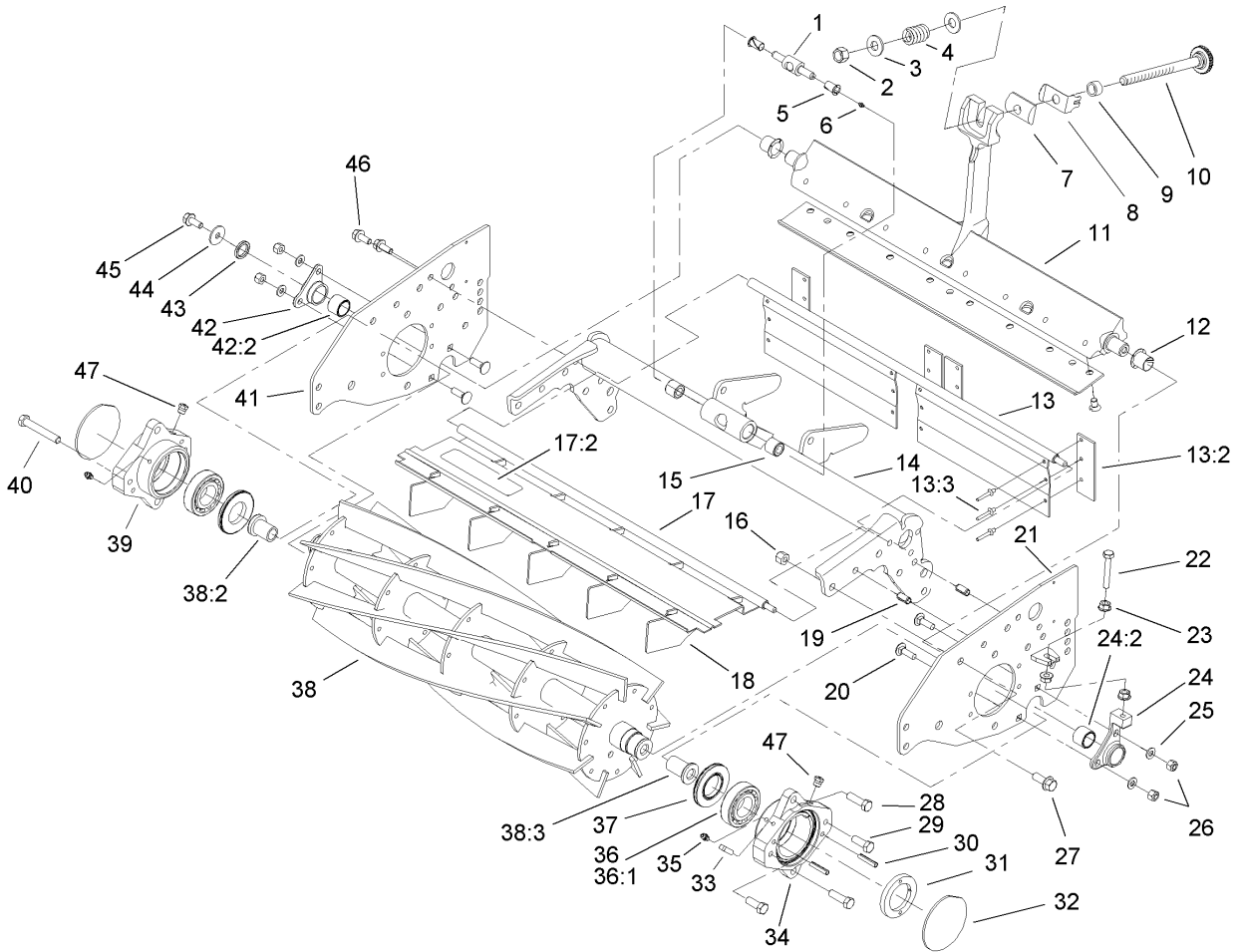

Reel and Frame Assembly (continued)

Ref	Part No.	Qty.	Description
40	323-12	2	Screw-HH
41	100-2267-01	1	Sideplate-RH
42	100-3380	1	RH Pivot Hub ASM
42:2	93-7501	1	Bushing ASM
43	93-7510	1	Ring-Quad
44	3256-82	1	Washer-Flat
45	33104-020	1	Screw-HHF
46	3234-5	2	Screw
47	302-34	2	Fitting-Lube
1 50	106-9605	1	Bedbar Pivot Kit

--	--	--	--

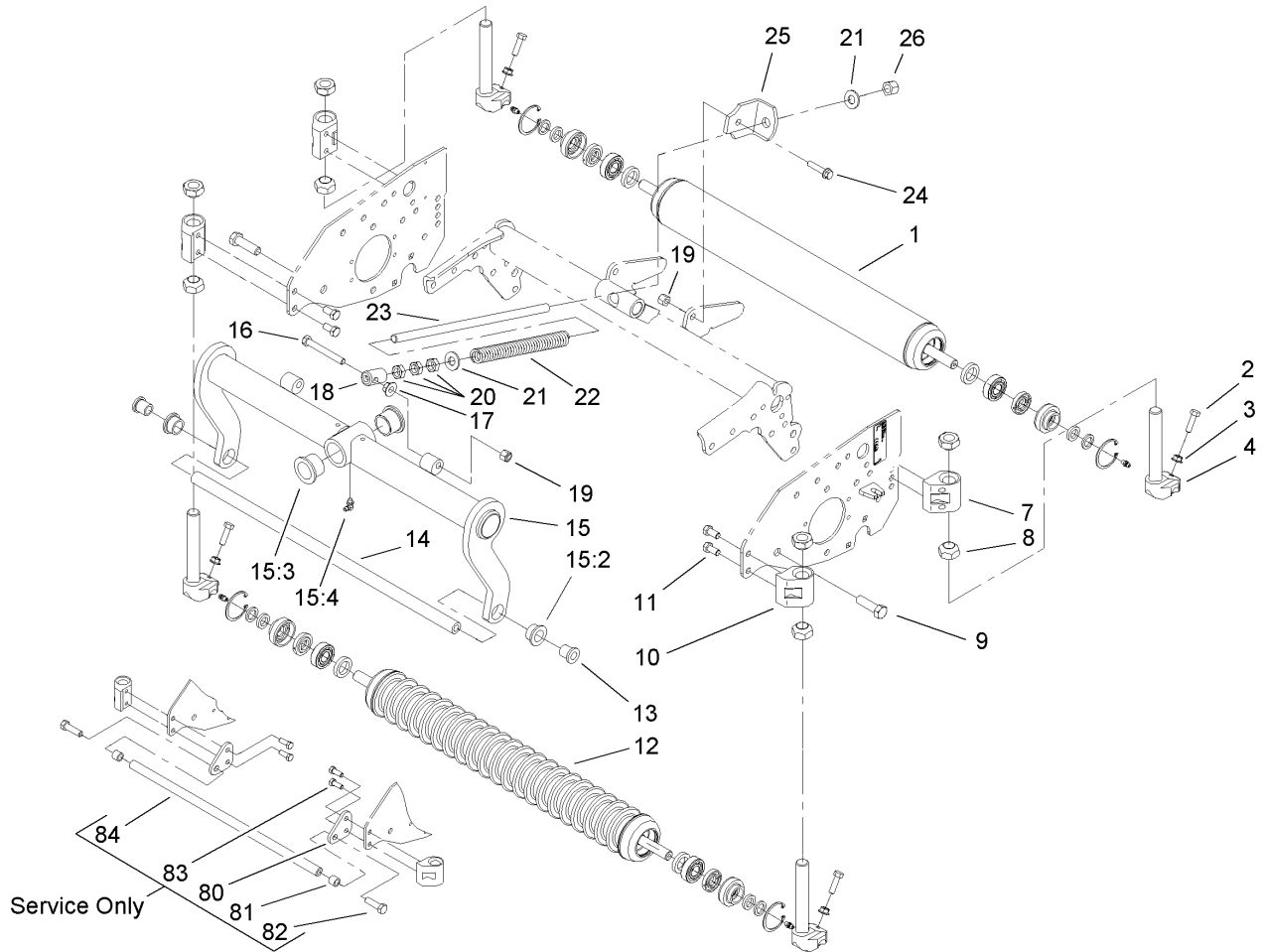

Roller and Carrier Frame Assembly

Ref	Part No.	Qty.	Description
⑤ 1	99-5749	1	Full Roller ASM
2	322-16	4	Screw-HH
3	32128-20	4	Nut-HF
4	100-2263	4	Support-Rod
7	100-2262-01	2	Bracket-Hoc, Rear
① 8	95-2790	1	Nut-Cone, Tall
8	95-2789	8	Nut-Cone
9	325-7	2	Screw-HH
10	100-2261-01	2	Bracket-Hoc, Front
11	323-4	8	Screw-HH
⑤ 12	99-8675	1	Shoulder Roller ASM
⑤ 12	100-9911	1	Shoulder Roller ASM
⑤ 12	100-9906	1	Wiehle Roller ASM
13	100-2276	2	Spacer-Frame
14	99-8693	1	Rod-Support
15	100-8011	1	Carrier Frame ASM
15:2	93-2877	2	Bushing
15:3	94-1291	2	Bushing
15:4	302-60	1	Fitting-Grease
16	99-8664	1	Screw-HH
17	32128-43	1	Nut-Flange
18	99-8662	1	Tube-Spring
19	3296-39	2	Nut-Lock, NI
20	3218-5	3	Nut-Jam

Ref	Part No.	Qty.	Description
21	87-7270	2	Washer-Thrust
22	92-7768	1	Spring-Compression
23	99-8661	1	Rod-Spring
24	3234-18	1	Screw-HHF
25	100-4992	1	Bracket-Spring
26	3296-23	1	Nut-Lock, NI
① ⑤ 50	106-9606	1	Roller Kit
80	100-9903	2	Bracket-Support
81	100-9919	2	Spacer
82	325-7	2	Screw-HH
83	323-6	4	Screw-HH
84	99-8693	1	Rod-Support

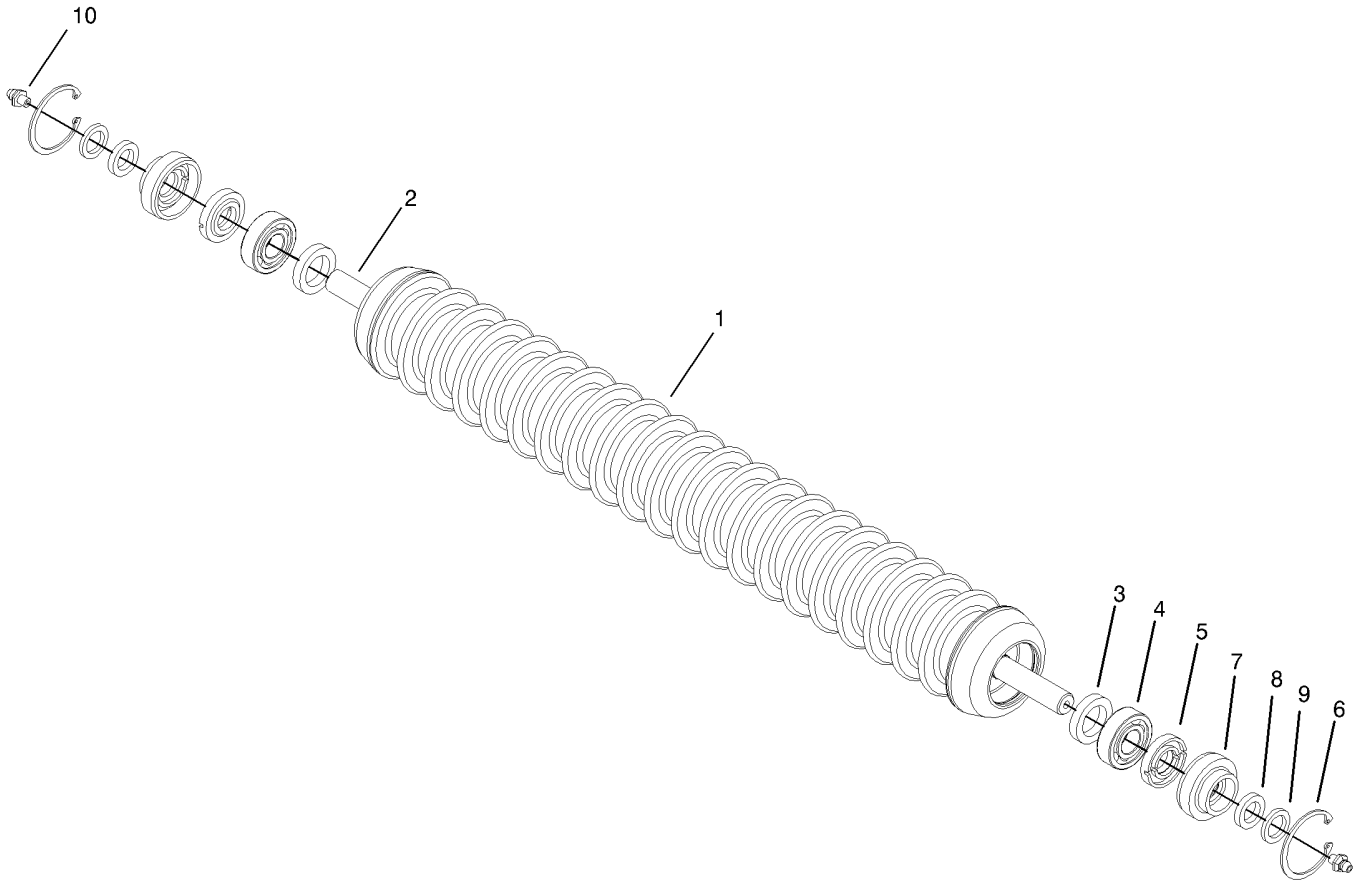

Wiehle Roller Assembly No. 100-9906

Ref	Part No.	Qty.	Description
1	100-9905-03	1	Wiehle Roller ASM
2	99-5748	1	Shaft-Roller
3	93-3007	2	Seal-Oil
4	109966	2	Bearing-Ball
5	93-1251	2	Seal-Inner
6	32120-62	2	Ring-Retaining
7	93-1252	2	Seal-Outer
8	253-70	2	Seal-Oil
9	93-2931	2	Washer-Roller
10	302-5	2	Fitting-Grease

--	--	--	--

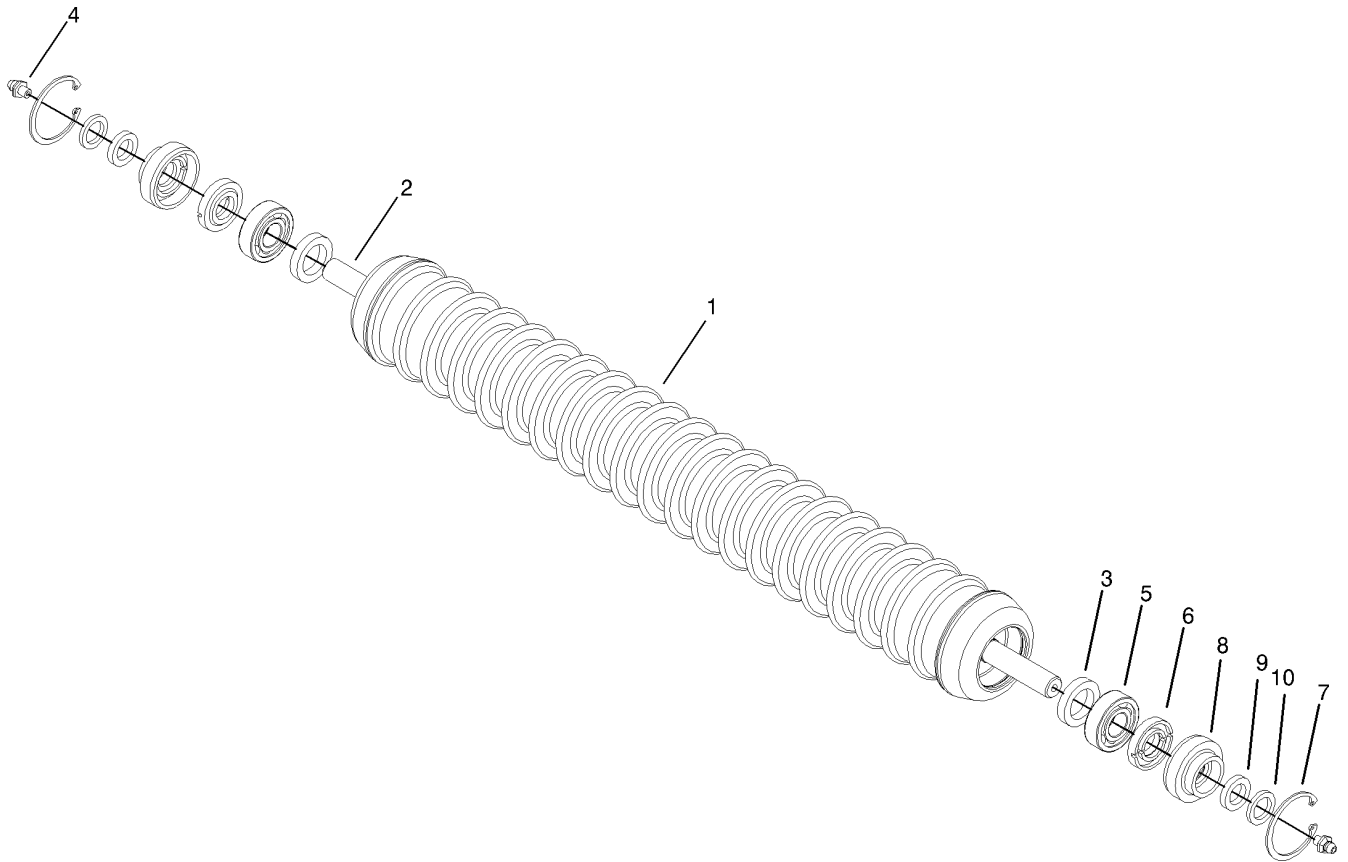

Optional Shoulder Roller Assembly No. 100-9911 (RM5500-D Series)

Ref	Part No.	Qty.	Description
1	100-9910-03	1	Shoulder Weihle Roller ASM
2	99-5748	1	Shaft-Roller
3	93-3007	2	Seal-Oil
4	302-5	2	Fitting-Grease
5	109966	2	Bearing-Ball
6	93-1251	2	Seal-Inner
7	32120-62	2	Ring-Retaining
8	93-1252	2	Seal-Outer
9	253-70	2	Seal-Oil
10	93-2931	2	Washer-Roller

--	--	--	--

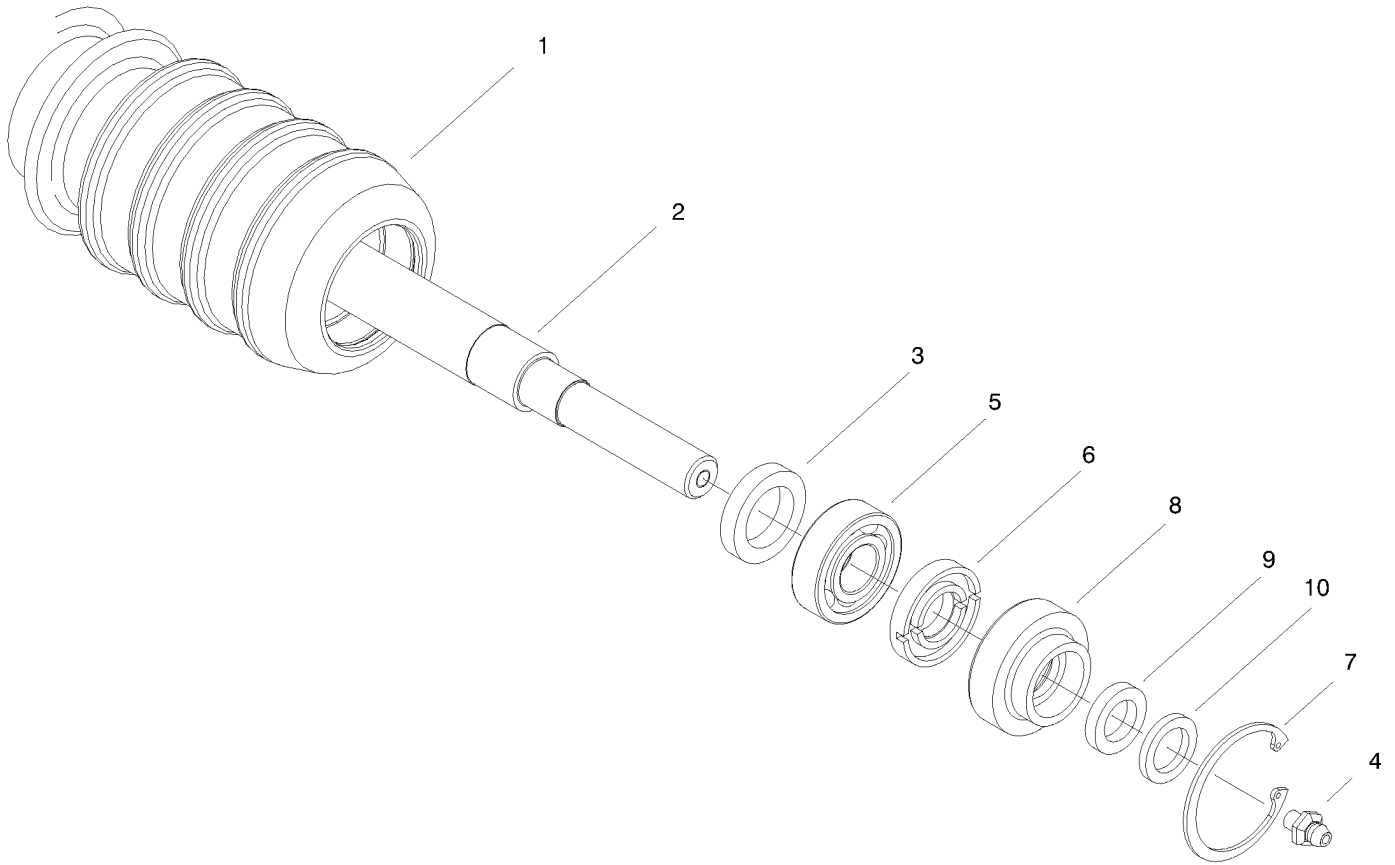

Optional Shoulder Roller Assembly No. 99-8675 (RM6000-D Series)

Ref	Part No.	Qty.	Description
1	99-8674-03	1	Shoulder Wiehle Roller ASM
2	99-5748	1	Shaft-Roller
3	93-3007	2	Seal-Oil
4	302-5	2	Fitting-Grease
5	109966	2	Bearing-Ball
6	93-1251	2	Seal-Inner
7	32120-62	2	Ring-Retaining
8	93-1252	2	Seal-Outer
9	253-70	2	Seal-Oil
10	93-2931	2	Washer-Roller

--	--	--	--

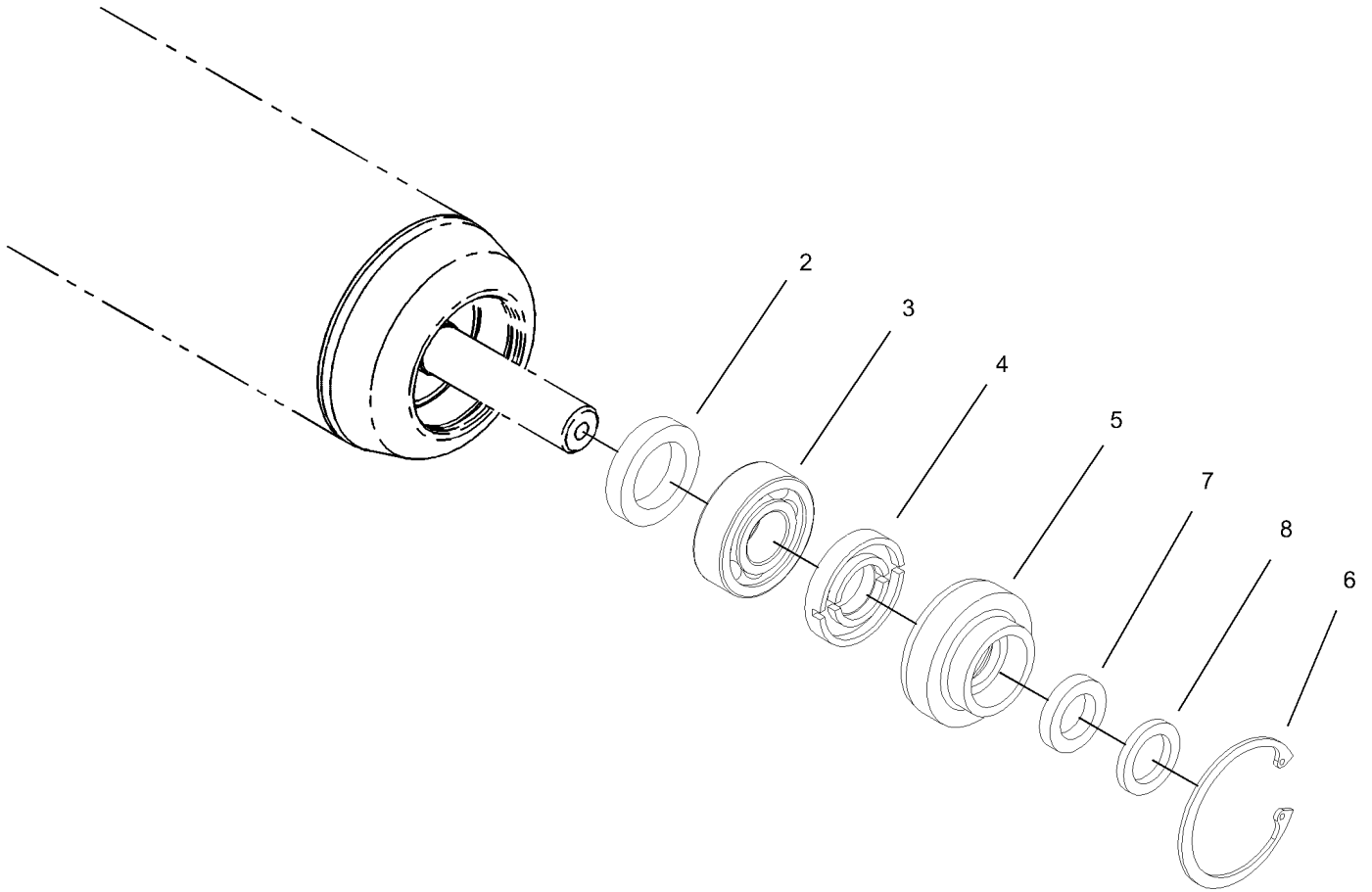

Roller Kit Assembly No. 106-9606

Ref	Part No.	Qty.	Description
2	93-3007	2	Seal-Oil
3	109966	2	Bearing-Ball
4	93-1251	2	Seal-Inner
5	93-1252	2	Seal-Outer
6	32120-62	2	Ring-Retaining
7	253-70	2	Seal-Oil
8	93-2931	2	Washer-Roller

--	--	--	--

NOTES

NOTES

