



Z555

**Z Master[®] with 60in TURBO FORCE[™] Side
Discharge Mower**

Model No. 74245-Serial No. 24000001 & Up

Operator's Manual



Warning



The engine exhaust from this product contains chemicals known to the State of California to cause cancer, birth defects, or other reproductive harm.

Important This engine is not equipped with a spark arrester muffler. It is a violation of California Public Resource Code Section 4442 to use or operate this engine on any forest-covered, brush-covered or grass-covered land. Other states or federal areas may have similar laws.

This spark ignition system complies with Canadian ICES-002.

Ce système d'allumage par étincelle de véhicule est conforme à la norme NMB-002 du Canada.

The enclosed Engine Owner's Manual is supplied for information regarding The U.S. Environmental Protection Agency (EPA) and the California Emission Control Regulation of emission systems, maintenance and warranty.

Keep this engine Owner's Manual with your unit. Should this engine Owner's Manual become damaged or illegible, replace immediately. Replacements may be ordered through the engine manufacturer.

Contents

	Page		Page
Introduction	3	Stopping the Machine	21
Safety	3	Adjusting the Height-of-Cut	21
Safe Operating Practices	3	Using the Lift Assist Lever	22
Slope Chart	7	Adjusting the Anti-Scalp Rollers	22
Safety and Instruction Decals	9	Adjusting the Flow Baffle	23
Gasoline and Oil	15	Positioning the Flow Baffle	23
Recommended Gasoline	15	Positioning the Seat	24
Using Stabilizer/Conditioner	15	Unlatching the Seat	24
Filling the Fuel Tank	15	Pushing the Machine by Hand	24
Check Engine Oil Level	15	Using the Side Discharge	25
Operation	16	Transporting Machines	25
Using the Rollover Protection System (ROPS) ..	16	Loading Machines	25
Think Safety First	17	Using the Z Stand	26
Controls	18	Tips for Mowing Grass	27
Operating the Parking Brake	18	Maintenance	29
Starting and Stopping the Engine	19	Recommended Maintenance Schedule	29
Operating the Power Take Off (PTO)	19	Servicing the Cutting Blades	30
The Safety Interlock System	20	Servicing the Air Cleaner	32
Driving Forward or Backward	20	Servicing the Engine Oil	33
		Servicing the Spark Plug	34
		Servicing the Fuel Filter	35
		Servicing the Fuel Tank	36
		Greasing and Lubrication	36
		Cleaning the Cooling Systems	38
		Checking the Tire Pressure	38
		Checking the Wheel Hub Slotted Nut	38
		Adjusting the Caster Pivot Bearing	39
		Servicing the Hydraulic System	39
		Adjusting the Handle Neutral	41
		Setting the Hydraulic Pump Neutral	42
		Adjusting the Tracking	43
		Replacing the Pump Drive Belt	43
		Adjusting the Parking Brake	44
		Servicing the Fuse	44
		Servicing the Battery	44
		Leveling the Mower at Three Positions	46
		Cleaning Under the Mower	48
		Inspecting the Belts	49
		Replacing the Mower Belt	49
		Adjusting the Mower Belt Tension	49
		Replacing the Grass Deflector	51
		Mercury Tilt Switch	51
		Disposing the Mercury Tilt Switch	51
		Cleaning and Storage	52
		Wiring Diagram	53
		Troubleshooting	54
		The Toro Total Coverage Guarantee	56

Introduction

Read this manual carefully to learn how to operate and maintain your product properly. The information in this manual can help you and others avoid injury and product damage. Although Toro designs and produces safe products, you are responsible for operating the product properly and safely.

Whenever you need service, genuine Toro parts, or additional information, contact an Authorized Service Dealer or Toro Customer Service and have the model and serial numbers of your product ready. Figure 1 illustrates the location of the model and serial numbers on the product.

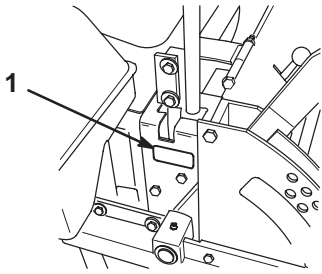

Figure 1

1. Location of the model and serial numbers

Write the product model and serial numbers in the space below:

Model No. _____
Serial No. _____

This manual identifies potential hazards and has special safety messages that help you and others avoid personal injury and even death. **Danger**, **Warning**, and **Caution** are signal words used to identify the level of hazard. However, regardless of the hazard, be extremely careful.

Danger signals an extreme hazard that *will* cause serious injury or death if you do not follow the recommended precautions.

Warning signals a hazard that *may* cause serious injury or death if you do not follow the recommended precautions.

Caution signals a hazard that may cause minor or moderate injury if you do not follow the recommended precautions.

This manual uses two other words to highlight information. **Important** calls attention to special mechanical information and **Note**: emphasizes general information worthy of special attention.

Safety

Improper use or maintenance by the operator or owner can result in injury. To reduce the potential for injury, comply with these safety instructions and always pay attention to the safety alert symbol, which means CAUTION, WARNING, or DANGER—“personal safety instruction.” Failure to comply with the instruction may result in personal injury or death.

This product is capable of amputating hands and feet and throwing objects. Always follow all safety instructions to avoid serious injury or death.

This product is designed for cutting and recycling grass or, when equipped with a grass bagger, for catching cut grass. Any use for purposes other than these could prove dangerous to user and bystanders.

Safe Operating Practices

The following instructions are from ANSI standard B71.4—1999.

Training

- Read the Operator’s Manual and other training material. If the operator(s) or mechanic(s) can not read English it is the owner’s responsibility to explain this material to them.
- Become familiar with the safe operation of the equipment, operator controls, and safety signs.
- All operators and mechanics should be trained. The owner is responsible for training the users.
- Never let children or untrained people operate or service the equipment. Local regulations may restrict the age of the operator.
- The owner/user can prevent and is responsible for accidents or injuries occurring to himself or herself, other people or property.

Preparation

- Evaluate the terrain to determine what accessories and attachments are needed to properly and safely perform the job. Only use accessories and attachments approved by the manufacturer.
- Wear appropriate clothing including hard hat, safety glasses and hearing protection. Long hair, loose clothing or jewelry may get tangled in moving parts.
- Inspect the area where the equipment is to be used and remove all objects such as rocks, toys and wire which can be thrown by the machine.

- Use extra care when handling gasoline and other fuels. They are flammable and vapors are explosive.
 - Use only an approved container
 - Never remove gas cap or add fuel with engine running. Allow engine to cool before refueling. Do not smoke.
 - Never refuel or drain the machine indoors.
- Check that operator's presence controls, safety switches and shields are attached and functioning properly. Do not operate unless they are functioning properly.

Operation

- Never run an engine in an enclosed area.
- Only operate in good light, keeping away from holes and hidden hazards.
- Be sure all drives are in neutral and parking brake is engaged before starting engine. Start the engine only from the operator's position.
- Never raise mower with the blades running.
- Never operate without the PTO shield, or other guards securely in place. Be sure all interlocks are functioning properly.
- Never operate with the discharge deflector raised, removed or altered, unless using a grass catcher.
- Do not change the engine governor setting or overspeed the engine.
- Stop on level ground, lower implements, disengage drives, engage parking brake, shut off engine before leaving the operator's position for any reason including emptying the catchers or unclogging the chute.
- Stop equipment and inspect blades after striking objects or if an abnormal vibration occurs. Make necessary repairs before resuming operations.
- Keep hands and feet away from the cutting units.
- Never carry passengers and keep pets and bystanders away.
- Be alert, slow down and use caution when making turns. Look behind and to the side before changing directions.
- Slow down and use caution when crossing roads and sidewalks. Stop blades if not mowing.
- Be aware of the mower discharge direction and do not point it at anyone.
- Do not operate the mower under the influence of alcohol or drugs.

- Use extreme care when loading or unloading the machine into a trailer or truck.
- Use care when approaching blind corners, shrubs, trees, or other objects that may obscure vision.

Slope Operation

- Do not mow slopes greater than 15 degrees.
- Do not mow near drop-offs, ditches, steep banks or water. Wheels dropping over edges can cause rollovers, which may result in serious injury, death or drowning.
- Do not mow slopes when grass is wet. Slippery conditions reduce traction and could cause sliding and loss of control.
- Do not make sudden turns or rapid speed changes.
- Use a walk behind mower and/or a hand trimmer near drop-offs, ditches, steep banks or water.
- Reduce speed and use extreme caution on slopes.
- Remove or mark obstacles such as rocks, tree limbs, etc. from the mowing area. Tall grass can hide obstacles.
- Watch for ditches, holes, rocks, dips, and rises that change the operating angle, as rough terrain could overturn the machine.
- Avoid sudden starts when mowing uphill because the mower may tip backwards.
- Be aware that loss of traction may occur going downhill. Weight transfer to the front wheels may cause drive wheels to slip and cause loss of braking and steering.
- Always avoid sudden starting or stopping on a slope. If tires lose traction, disengage the blades and proceed slowly off the slope.
- Follow the manufacturer's recommendations for wheel weights or counterweights to improve stability.
- Use extreme care with grass catchers or other attachments. These can change the stability of the machine and cause loss of control.

Using the Rollover Protection System (ROPS)

- Keep the roll bar in the raised and locked position and use the seat belt when operating the machine.
- Be certain that the seat belt can be released quickly in the event of an emergency.
- Be aware there is no rollover protection when the roll bar is down.

- Check the area to be mowed and never fold the ROPS in areas where there are slopes, drop offs or water.
- Lower the rollbar only when absolutely necessary. Do not wear the seat belt with the roll bar folded down.
- Check carefully for overhead clearances (i.e. branches, doorways, electrical wires) before driving under any objects and do not contact them.

Maintenance and storage

- Disengage drives, lower implement, set parking brake, stop engine and remove key or disconnect spark plug wire. Wait for all movement to stop before adjusting, cleaning or repairing.
- Clean grass and debris from cutting units, drives, mufflers, and engine to help prevent fires. Clean up oil or fuel spillage.
- Let engine cool before storing and do not store near flame.
- Shut off fuel while storing or transporting. Do not store fuel near flames or drain indoors.
- Park machine on level ground. Never allow untrained personnel to service machine.
- Use jack stands to support components when required.
- Carefully release pressure from components with stored energy.
- Disconnect battery or remove spark plug wire before making any repairs. Disconnect the negative terminal first and the positive last. Reconnect positive first and negative last.
- Use care when checking blades. Wrap the blade(s) or wear gloves, and use caution when servicing them. Only replace blades. Never straighten or weld them.
- Keep hands and feet away from moving parts. If possible, do not make adjustments with the engine running.
- Charge batteries in an open well ventilated area, away from spark and flames. Unplug charger before connecting or disconnecting from battery. Wear protective clothing and use insulated tools.
- Keep all parts in good working condition and all hardware tightened. Replace all worn or damaged decals.
- Use only Toro-approved attachments. Warranty may be voided if used with unapproved attachments.

Slope Chart

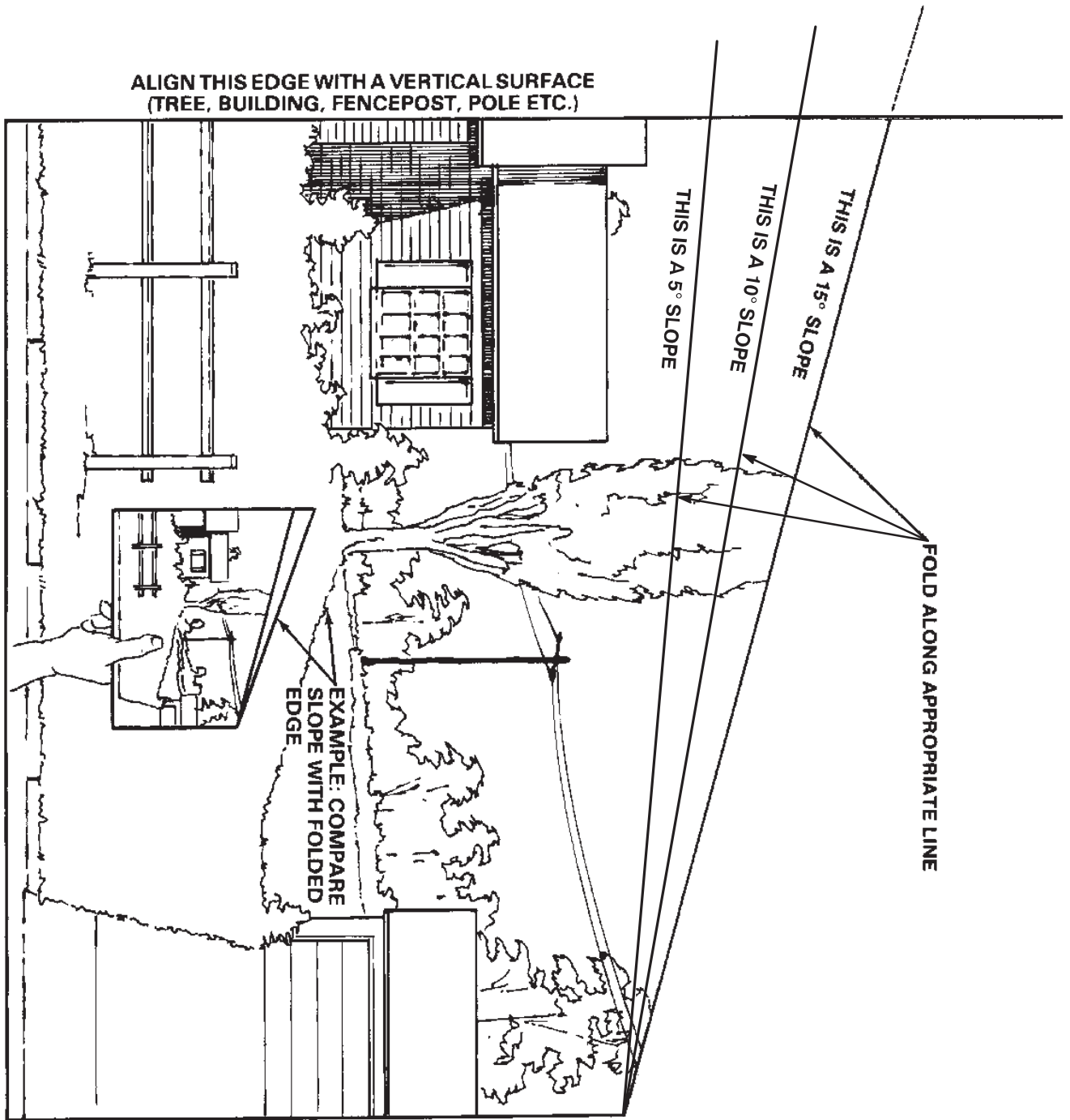

Safety and Instruction Decals



Safety decals and instructions are easily visible to the operator and are located near any area of potential danger. Replace any decal that is damaged or lost.

IMPORTANT:
BEFORE STARTING ENGINE
CLEAN GRASS FROM PUMP
DRIVE BELT COMPARTMENT.
CHECK MORE OFTEN IN DRY
CONDITIONS

1-633462



43-8480

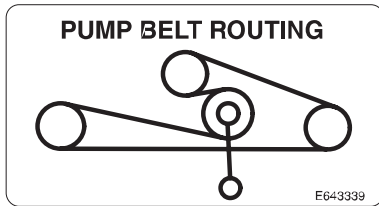

1-643339



54-9220



1-523552

MERCURY SWITCH 633782
SEE OPERATOR'S MANUAL
FOR DISPOSAL INSTRUCTIONS
E643401

1-643401



58-6520

1. Grease



66-1340



68-8340



98-4387

1. Warning—wear hearing protection.



98-5954



103-0368

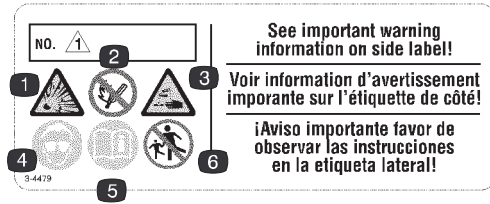

104-4163

1. Explosion hazard
2. No fire, open flames, or smoking.
3. Caustic liquid/chemical burn hazard
4. Wear eye protection
5. Read the *Operator's Manual*.
6. Keep bystanders a safe distance from the battery.



104-7759

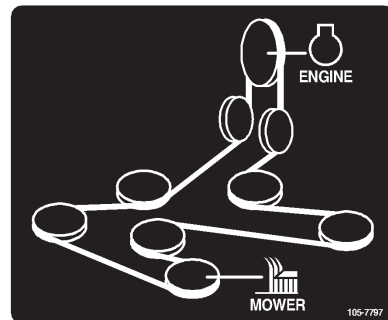

105-7797

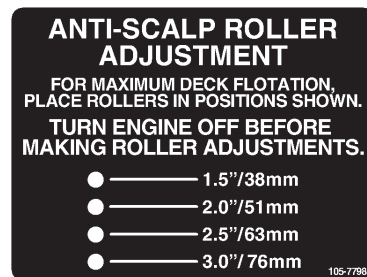

105-7798



104-8569



107-1613



107-1864

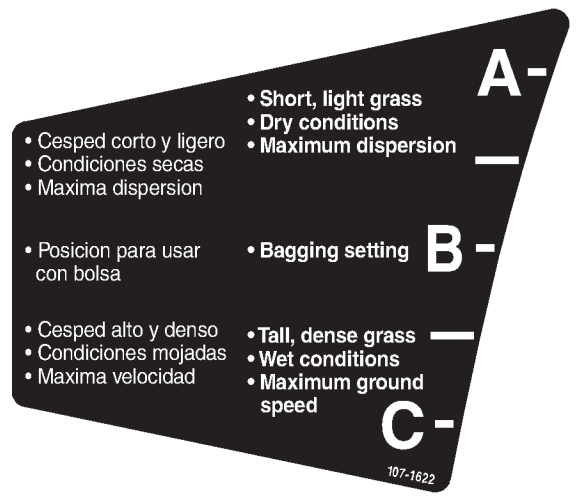

107-1622



107-2102

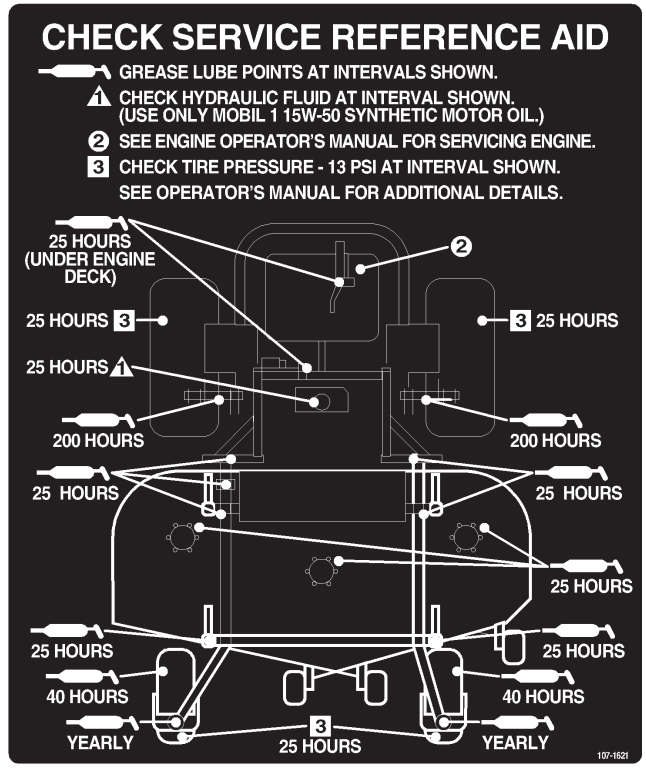

107-1621



106-9969

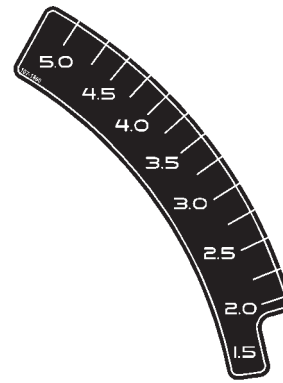

107-1860

⚠ WARNING

- Operating on wet grass or steep slopes can cause sliding and loss of control.
- Wheels dropping over edges can cause rollovers, which may result in serious injury, death or drowning.
- To avoid loss of control and possibility of rollover:
 - Do NOT operate near drop-offs or near water.
 - Do NOT operate on slopes greater than 15°.
 - Reduce speed and use extreme caution on slopes.
 - Avoid sudden turns or rapid speed changes.
- There is no rollover protection when the roll bar is down.
- Always keep roll bar in the raised and locked position and use seat belt.
- Read and follow rollover protection instructions and warning.

107-2112

Greater than 15°

107-2112

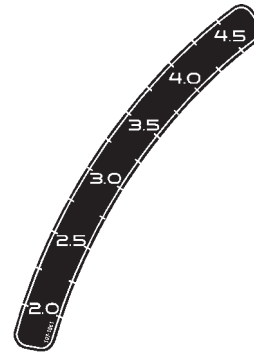

107-1861

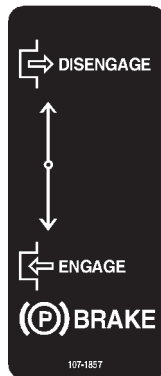

107-1857

MOTION CONTROL

↑
N
R
↓

CAUTION

Mercury in this switch is poisonous and can cause severe illness.

- * Never attempt to open or repair switch.
- * Avoid contact with mercury. See operator's manual for disposal rules.

MOTION CONTROL

↑
N
R
↓

103-2433

DRIVE WHEEL RELEASE

Use 5/8 wrench
One turn counterclockwise to release
Do not over-tighten

103-2433

For replacement manual, send model & serial number to: The Toro Co., 8111 Lyndale Ave. S., Bloomington, MN 55420.

IMPORTANT: Before starting engine clean grass from pump drive belt compartment. Check more often in dry conditions.

⚠ WARNING

To avoid serious injury or death:

- Read and understand the operator's manual before using this machine.
- Do not operate unless trained to safely use this machine.
- Do not operate under the influence of alcohol or drugs.
- Do not operate without shields, guards, and safety devices in place and working.
- Check the function of all safety interlocks daily.
- Do not defeat interlocks.
- Hearing protection is recommended.

106-9989

⚠ DANGER

- Pick up objects that could be thrown by the blades.
- Never mow when bystanders are in the area.
- Never carry passengers.
- Look behind and to the side before changing directions.
- Stop the engine and remove key before adjusting, servicing or cleaning machine and attachments.

Before leaving the operator's position:

- Stop the engine and disengage the blade.
- Move the levers out to the neutral lock position.
- Set the parking brake.
- Avoid blades unless engine and blades are stopped.



106-7492

106-7492

MAINTENANCE FREE • SANS ENTRETIEN • LIBRE DE MANTENIMIENTO

NIVEAU MAXIMUM / NIVEAU MINIMUM / MAXIMUM FILL / MINIMUM FILL / CAPACIDAD MAXIMA / CAPACIDAD MINIMA

⚠ DANGER/POISON ¡PELIGRO/VENENO!

<p>3 EXPLOSIVE GASES CAN CAUSE BLINDNESS OR INJURY.</p> <p>PROTEGER LES YEUX. GAZ EXPLOSIFS PEUVENT RENDRE AVEUGLE OU PROVOQUER DES LESIONS.</p> <p>PROTEJA LOS OJOS. GASES EXPLOSIVOS PUEDEN CAUSAR CEGUERA O DAÑO.</p>	<p>4 NO SPARKS • FLAMES • SMOKING</p> <p>ÉLOIGNER</p> <p>• ÉTINCELLES • FLAMMES • CIGARETTES</p> <p>NO</p> <p>• CHISPAS • FLAMAS • FUMAR</p>	<p>5 SULFURIC ACID CAN CAUSE BLINDNESS OR SEVERE BURNS.</p> <p>ACIDE</p> <p>SULFURIQUE PEUT RENDRE AVEUGLE OU PROVOQUER DES BRULURES GRAVES.</p> <p>ACIDO Sulfurico PUEDE CAUSAR CEGUERA O QUEMADURAS SEVERAS.</p>	<p>6 FLUSH EYES IMMEDIATELY WITH WATER. GET MEDICAL HELP FAST.</p> <p>RINCER IMMEDIATEMENT LES YEUX A GRANDE EAU. CONTACTER RAPIDEMENT UN MEMBRE DE LA PROFESSION MEDICALE.</p> <p>LAVE LOS OJOS DE INMEDIATO. CONSIGA AYUDA MEDICA RAPIDO.</p>
---	---	--	--

HOW TO ACTIVATE DRY CHARGED BATTERIES

- Use only battery electrolyte (1.265 Sp.Gr.) to fill battery initially.
- Do not overfill. Let stand for 15 minutes.
- Charge battery at 4-5 amps until specific gravity is 1.250 or higher and temperature is at least 60°F. - all cells gassing freely.
- After battery has been activated, add only water to replace normal loss.

KEEP OUT OF THE REACH OF CHILDREN. DO NOT TIP. DO NOT OPEN BATTERY!
MAINTENIR HORS DE LA PORTÉE DES ENFANTS. NE RENVERSEZ PAS. MANTENGASE FUERA DEL ALCANCE DE LOS NIÑOS. NO INCLINE. N'OUVREZ PAS LA BATTERIE! NO ABRA LA BATERIA!

1. Contains lead; do not discard.
 2. Recycle
 3. Wear eye protection; explosive gases can cause blindness and other injuries
 4. No sparks, flame, or smoking
 5. Sulfuric acid can cause blindness or severe burns.
 6. Flush eyes immediately with water and get medical help fast.
 7. Maximum fill line
 8. Minimum fill line
 9. Instructions for activating the battery

3-1808 Dist. by:/por:/par: The Toro Company, Bloomington, MN 55420 MADE IN U.S.A. • FABRIQUE AUX E.U.A. • HECHO EN E.U.A.

104-4164

- Contains lead; do not discard.
- Recycle
- Wear eye protection; explosive gases can cause blindness and other injuries
- No sparks, flame, or smoking
- Sulfuric acid can cause blindness or severe burns.
- Flush eyes immediately with water and get medical help fast.
- Maximum fill line
- Minimum fill line
- Instructions for activating the battery

Gasoline and Oil

Recommended Gasoline

Use UNLEADED Regular Gasoline suitable for automotive use (85 pump octane minimum). Leaded regular gasoline may be used if unleaded regular is not available.

Important Never use methanol, gasoline containing methanol, or gasohol containing more than 10% ethanol because the fuel system could be damaged. Do not mix oil with gasoline.



Danger



In certain conditions, gasoline is extremely flammable and highly explosive. A fire or explosion from gasoline can burn you and others and can damage property.

- Fill the fuel tank outdoors, in an open area, when the engine is cold. Wipe up any gasoline that spills.
- Never fill the fuel tank inside an enclosed trailer.
- Do not fill the fuel tank completely full. Add gasoline to the fuel tank until the level is 1/4 to 1/2 inch (6 to 13 mm) below the bottom of the filler neck. This empty space in the tank allows gasoline to expand.
- Never smoke when handling gasoline, and stay away from an open flame or where gasoline fumes may be ignited by a spark.
- Store gasoline in an approved container and keep it out of the reach of children. Never buy more than a 30-day supply of gasoline.
- Always place gasoline containers on the ground away from your vehicle before filling.
- Do not fill gasoline containers inside a vehicle or on a truck or trailer bed because interior carpets or plastic truck bed liners may insulate the container and slow the loss of any static charge.
- When practical, remove gas-powered equipment from the truck or trailer and refuel the equipment with its wheels on the ground.
- If this is not possible, then refuel such equipment on a truck or trailer from a portable container, rather than from a gasoline dispenser nozzle.
- If a gasoline dispenser nozzle must be used, keep the nozzle in contact with the rim of the fuel tank or container opening at all times until fueling is complete.
- Do not operate without entire exhaust system in place and in proper working condition.



Warning



Gasoline is harmful or fatal if swallowed. Long-term exposure to vapors can cause serious injury and illness.

- Avoid prolonged breathing of vapors.
- Keep face away from nozzle and gas tank or conditioner opening.
- Keep gas away from eyes and skin.

Using Stabilizer/Conditioner

Use a fuel stabilizer/conditioner in the machine to provide the following benefits:

- Keeps gasoline fresh during storage of 90 days or less. For longer storage it is recommended that the fuel tank be drained.
- Cleans the engine while it runs
- Eliminates gum-like varnish buildup in the fuel system, which causes hard starting

Important Do not use fuel additives containing methanol or ethanol.

Add the correct amount of gas stabilizer/conditioner to the gas.

Note: A fuel stabilizer/conditioner is most effective when mixed with fresh gasoline. To minimize the chance of varnish deposits in the fuel system, use fuel stabilizer at all times.

Filling the Fuel Tank

1. Shut the engine off and set the parking brake.
2. Clean around each fuel tank cap and remove the cap. Add unleaded regular gasoline to both fuel tanks, until the level is 1/4 to 1/2 inch (6 mm to 13 mm) below the bottom of the filler neck. This space in the tank allows gasoline to expand. Do not fill the fuel tanks completely full.
3. Install fuel tank caps securely. Wipe up any gasoline that may have spilled.

Check Engine Oil Level

Before you start the engine and use the machine, check the oil level in the engine crankcase; refer to Checking Oil Level, page 33.

Operation

Note: Determine the left and right sides of the machine from the normal operating position.

Using the Rollover Protection System (ROPS)

⚠
Warning
⚠

To avoid injury or death from rollover: keep the roll bar in the raised locked position and use the seat belt.

Ensure that the rear part of the seat is secured with the seat latch.

⚠
Warning
⚠

There is no rollover protection when the roll bar is in the down position.

- Lower the roll bar only when absolutely necessary.
- Do not wear the seat belt when the roll bar is in the down position.
- Drive slowly and carefully.
- Raise the roll bar as soon as clearance permits.
- Check carefully for overhead clearances (i.e. branches, doorways, electrical wires) before driving under any objects and do not contact them.

Important Lower the roll bar only when absolutely necessary.

1. To lower the roll bar, loosen the front handles (Fig. 4).
2. Remove the hairpin cotter pins and remove the two pins (Fig. 3).
3. Lower the the roll bar to the down position. There are two down positions. See Figure 2 for the positions.
4. Install the two pins and secure them with the hairpin cotter pins (Fig. 3).

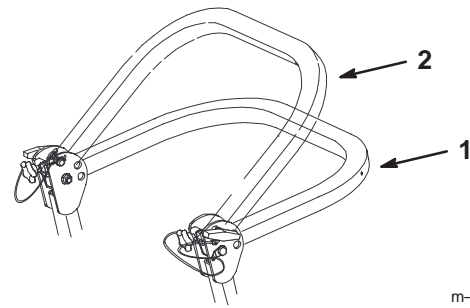

Figure 2

1. Full down position
2. Down position with bagger installed

m-6836

Important Always use the seat belt with the roll bar in the raised position.

Important Ensure that the rear part of the seat is secured with the seat latch.

5. To raise the roll bar, remove the hairpin cotter pins and remove the two pins (Fig. 3).
6. Raise the roll bar to the upright position and install the two pins and secure them with the hairpin cotter pins (Fig. 3).

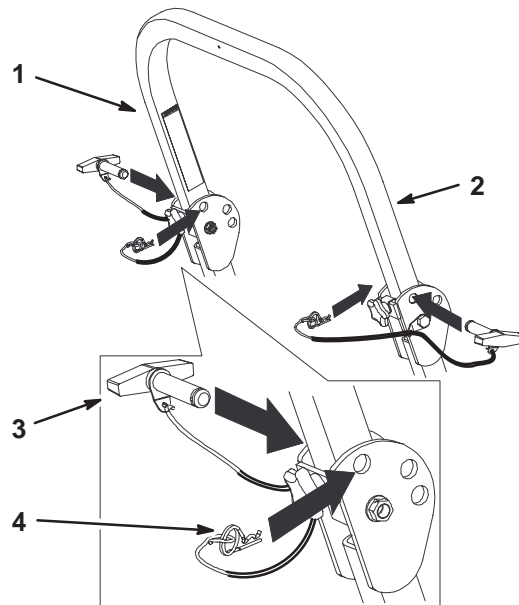

Figure 3

1. Roll bar
2. Raised position
3. Pin
4. Hairpin cotter pin

m-6893

- Tighten the front handles against the center roll bar ends (Fig. 3).

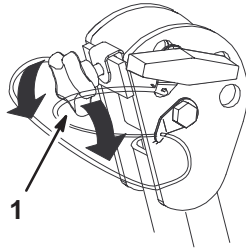

Figure 4

m-6897

- Front handle

Think Safety First

Please read all safety instructions and symbols in the safety section. Knowing this information could help you or bystanders avoid injury.

! **Danger** !

Operating on wet grass or steep slopes can cause sliding and loss of control.

Wheels dropping over edges can cause rollovers, which may result in serious injury, death or drowning.

There is no rollover protection when the roll bar is down.

Always keep the roll bar in the raised and locked position and use the seat belt.

Read and follow the rollover protection instructions and warnings.

To avoid loss of control and possibility of rollover:

- **Do not operate near drop-offs or near water.**
- **Do not operate on slopes greater than 15 degrees.**
- **Reduce speed and use extreme caution on slopes.**
- **Avoid sudden turns or rapid speed changes.**

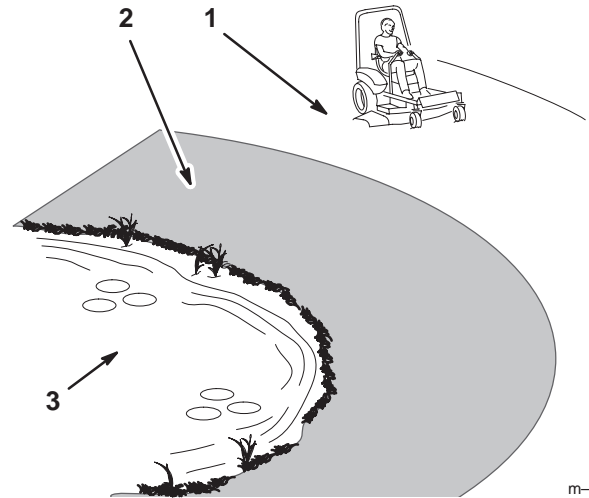

Figure 5

m-6478

- Safe Zone—use the Z Master here on slopes less than 15 degrees or flat areas.
- Use walk behind mower and/or hand trimmer near drop-offs and water.
- Water

The use of protective equipment for eyes, ears, feet, and head is recommended.

! **Caution** !

This machine produces sound levels in excess of 85 dBA at the operators ear and can cause hearing loss through extended periods of exposure.

Wear hearing protection when operating this machine.



Figure 6

- Warning—wear hearing protection.

Controls

Become familiar with all the controls (Fig. 7 and 8) before you start the engine and operate the machine.

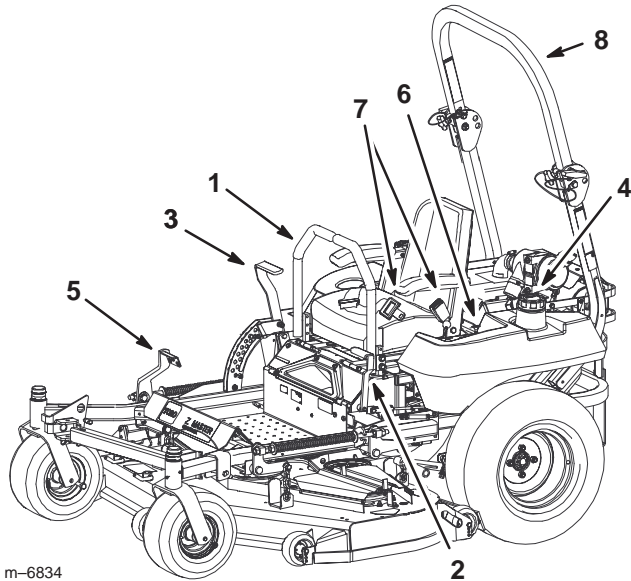

Figure 7

- | | |
|--------------------------|----------------------|
| 1. Motion control lever | 5. Lift assist lever |
| 2. Parking brake lever | 6. Controls |
| 3. Height-of-cut lever | 7. Seat belt |
| 4. Fuel cap (both sides) | 8. Roll bar |

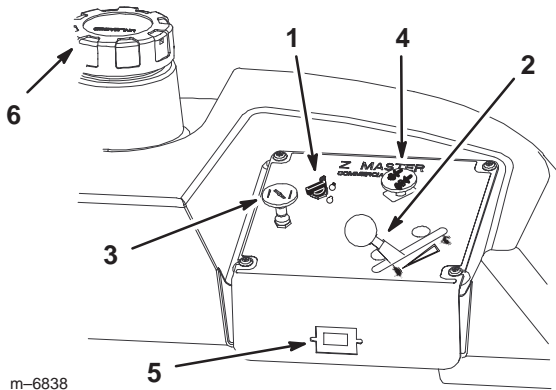

Figure 8

- | | |
|--------------------|-------------------------|
| 1. Ignition switch | 4. Power take off (PTO) |
| 2. Throttle | 5. Hour meter |
| 3. Choke | 6. Gas cap |

Using the Hour Meter

The hour meter records the number of hours the engine has operated. It operates when the engine is running. Use these times for scheduling regular maintenance.

Unlatch the seat and lift it up to view the hour meter (Fig. 8).

Operating the Parking Brake

Always set the parking brake when you stop the machine or leave it unattended.

Setting the Parking Brake

1. Move the motion control levers (Fig. 7) out to the neutral lock position.
2. Pull back and up on the parking brake lever to set the parking brake (Fig. 9). The parking brake lever should stay firmly in the **engaged** position.

Warning

Parking brake may not hold machine parked on a slope and could cause personal injury or property damage.

Do not park on slopes unless wheels are chocked or blocked

Releasing the Parking Brake

1. Push forward and down on the parking brake lever to release the parking brake (Fig. 9). The parking brake is **disengaged** and the lever will rest against the brake stop.

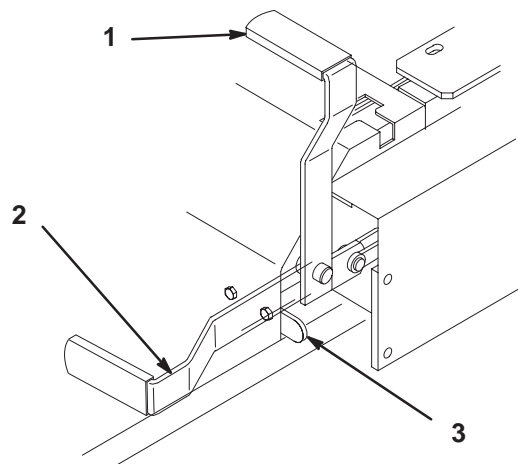

Figure 9

- | | |
|----------------------|---------------|
| 1. Parking brake-ON | 3. Brake Stop |
| 2. Parking brake-OFF | |

Starting and Stopping the Engine

Starting the Engine

1. Sit on the seat and move the motion controls to neutral locked position.
2. Set the parking brake; refer to Setting the Parking Brake, page 18.
3. Move the PTO (power take off) switch to the off position (Fig. 10).
4. Move the choke control to the **on** position before starting a cold engine.

Note: A warm or hot engine may **not** require choking. After engine starts, move choke control to **run** position.

5. Move the throttle control to the **fast** position before starting a cold engine.
6. Turn the ignition key to start. When the engines starts, release the key.

Important Do not engage starter for more than 10 seconds at a time. If engine fails to start allow 30 second cool-down period between attempts. Failure to follow these instructions can burn out starter motor.

7. After the engine starts, move the choke to off (Fig. 11). If the engine stalls or hesitates, move the choke back to on for a few seconds. Then move the throttle lever to desired setting. Repeat this as required.

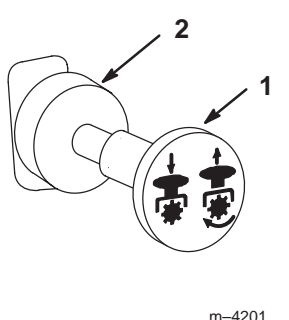

m-4201

Figure 10

1. PTO-On
2. PTO-Off

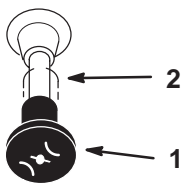

m-2719

Figure 11

1. Choke-On
2. Choke-Off

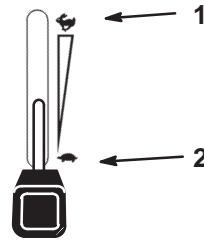

m-2720

Figure 12

1. Throttle-Fast
2. Throttle-Slow

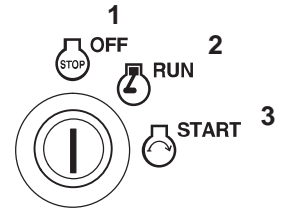

M-4268

IGNITION

Figure 13

1. Off
2. Run
3. Start

Stopping the Engine

1. Push the PTO to the off position (Fig. 12).
2. Move the throttle lever midway between the slow and fast positions (Fig. 12).
3. Let the engine idle for 60 seconds (Fig. 13).
4. Turn the ignition key to the off position and remove the key (Fig. 13).
5. Close the fuel shut off valve before transporting or storing the machine (Fig. 46).

Important Make sure that the fuel shut off valve is closed before transporting or storing the machine, as fuel leakage may occur. Set the parking brake before transporting. Make sure to remove the key as the fuel pump may run and cause the battery to lose charge.

⚠
Caution
⚠

Children or bystanders may be injured if they move or attempt to operate the tractor while it is unattended.

Always remove the ignition key and set the parking brake when leaving the machine unattended, even if just for a few minutes.

Operating the Power Take Off (PTO)

The power take off (PTO) switch engages and disengages power to the electric clutch.

Engaging the PTO

1. While seated in the seat, release pressure on the traction control levers and place in neutral.
2. Place the throttle to the fast position.
3. Pull out on the power take off (PTO) switch to engage (Fig. 14).

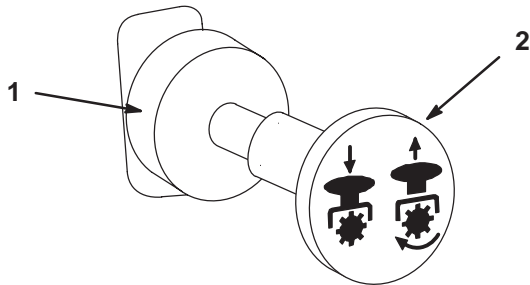

Figure 14

1. PTO—Off

2. PTO—On

m-4201

Disengaging the PTO

To disengage, push the PTO switch to the off position (Fig. 14).

The Safety Interlock System

! **Caution** !

If safety interlock switches are disconnected or damaged the machine could operate unexpectedly causing personal injury.

- **Do not tamper with the interlock switches.**
- **Check the operation of the interlock switches daily and replace any damaged switches before operating the machine.**

Understanding the Safety Interlock System

The safety interlock system is designed to prevent the engine from starting unless:

- You are sitting on the seat.
- The parking brake is engaged.
- The power take off (PTO) is disengaged.
- The motion control levers are in neutral locked position.

The safety interlock system also is designed to stop the engine when the traction controls are moved from the locked position with the parking brake **engaged** or if you rise from the seat when the PTO is **on** engaged.

Testing the Safety Interlock System

Test the safety interlock system before you use the machine each time. If the safety system does not operate as described below, have an Authorized Service Dealer repair the safety system immediately.

1. Sitting on the seat, engage the parking brake and move the PTO to on. Try starting the engine; the engine should not crank.
2. Sitting on the seat, engage the parking brake and move the PTO to off. Move either motion control lever (out of neutral locked position). Try starting the engine; the engine should not crank. Repeat for other control lever.
3. Sitting on the seat, engage the parking brake, move the PTO switch to off and move the motion control levers to neutral lock position. Now start the engine. While the engine is running, release the parking brake, engage the PTO and rise slightly from the seat; the engine should stop.
4. Sitting on the seat, engage the parking brake, move the PTO switch to off and move the motion control levers to neutral lock position. Now start the engine. While the engine is running, center either motion control and move (forward or reverse); the engine should stop. Repeat for other motion control.
5. Sitting on the seat, disengage the parking brake, move the PTO switch to off and move the motion control levers to neutral lock position. Try starting the engine; the engine should not crank.

Driving Forward or Backward

The throttle control regulates the engine speed as measured in rpm (revolutions per minute). Place the throttle control in the fast position for best performance. Always operate in the full throttle position when mowing.

Caution

Machine can spin very rapidly. Operator may lose control of machine and cause personal injury or damage to machine.

- Use caution when making turns.
- Slow the machine down before making sharp turns.

Driving Forward

1. Release the parking brake; refer to Releasing the Parking Brake, page 18.
2. Move the levers to the center, un-locked position.
3. To go forward, slowly push the motion control levers forward (Fig. 15).

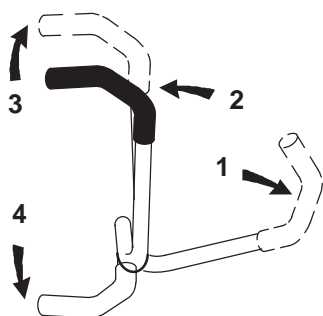

m-2715

Figure 15

- | | |
|---|-------------|
| 1. Motion control lever-neutral lock position | 3. Forward |
| 2. Center un-lock position | 4. Backward |

Note: The engine will kill if the traction control levers are moved with the parking brake engaged.

To go straight, apply equal pressure to both motion control levers (Fig. 15).

To turn, move the motion control lever toward neutral in the direction you want to turn (Fig. 15).

The farther you move the traction control levers in either direction, the faster the machine will move in that direction.

To stop pull the motion control levers to the neutral position.

Driving Backward

1. Move the levers to the center, un-locked position.
2. To go backward, slowly pull the motion control levers rearward (Fig. 15).

To go straight, apply equal pressure to both motion control levers (Fig. 15).

To turn, release pressure on the motion control lever toward the direction you want to turn (Fig. 15).

To stop push the motion control levers to the neutral position.

Stopping the Machine

To stop the machine, move the traction control levers to neutral and move to locked position, disengage the power take off (PTO), and turn the ignition key to off. Also set the parking brake when you leave the machine; refer to Setting the Parking Brake, page 18. Remember to remove the key from the ignition switch.

Caution

Children or bystanders may be injured if they move or attempt to operate the tractor while it is unattended.

Always remove the ignition key and set the parking brake when leaving the machine unattended, even if just for a few minutes.

Adjusting the Height-of-Cut

The height-of-cut is adjusted from 1-1/2 to 5 inch (38 to 127 mm) in 1/4 inch (6 mm) increments by relocating clevis pin into different hole locations.

1. Raise the height-of-cut lever to the transport position (also the 5 inch (127 mm) cutting height position) (Fig. 16).
2. To adjust, remove the clevis pin from the height-of-cut bracket (Fig. 16).
3. Select a hole in height-of-cut bracket corresponding to the height-of-cut desired and, insert the clevis pin (Fig. 16).
4. Move the lever to the selected height.

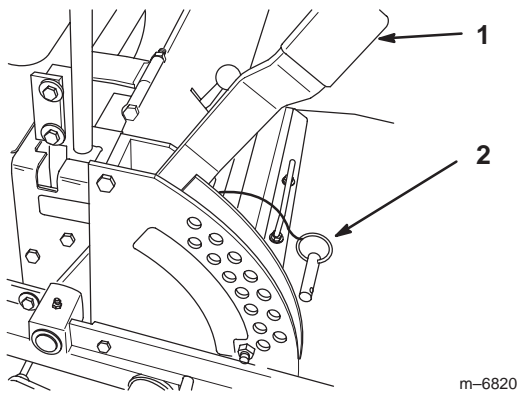

Figure 16

1. Height of cut lever
2. Clevis Pin

Using the Lift Assist Lever

The lift assist lever is used along with the height-of-cut lever for raising the mower. This allows for easier raising of the mower.

1. Place your foot onto lift assist lever.
2. Press on the lift assist lever while pulling up on the height-of-cut lever (Fig. 17).

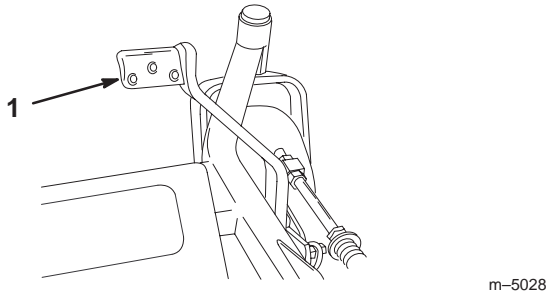

Figure 17

1. Lift Assist Lever

Adjusting the Anti-Scalp Rollers

Whenever you change the height-of-cut, it is recommended to adjust the height of the anti-scalp rollers.

1. Disengage the power take off (PTO) and turn the ignition key to off. Move levers to neutral locked position and apply the parking brake. Remove the key.
2. After adjusting the height-of-cut, adjust the rollers by removing the flange nut, bushing, spacer, and bolt (Fig. 18).

Note: The two middle rollers will not have a spacer (Fig. 19).

3. Select a hole so the anti-scalp roller is positioned to the nearest corresponding height-of-cut desired (Fig. 18).
4. Install the flange nut, bushing, spacer, and bolt. Torque to 40–45 ft-lb (54–61 N·m) (Fig. 18).
5. Repeat this adjustment on the other anti-scalp rollers.

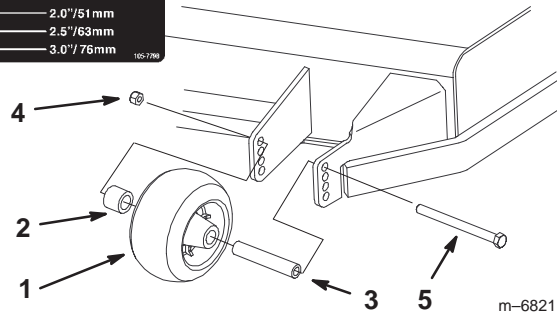
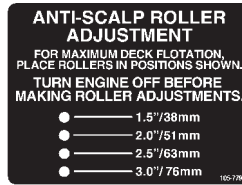

Figure 18

1. Anti-scalp roller
2. Spacer
3. Bushing
4. Flange Nut
5. Bolt

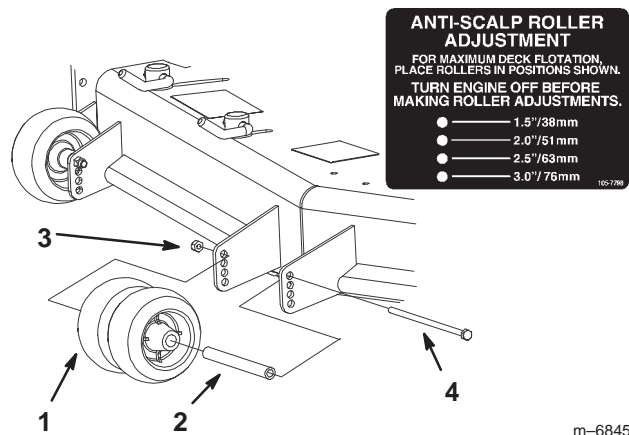
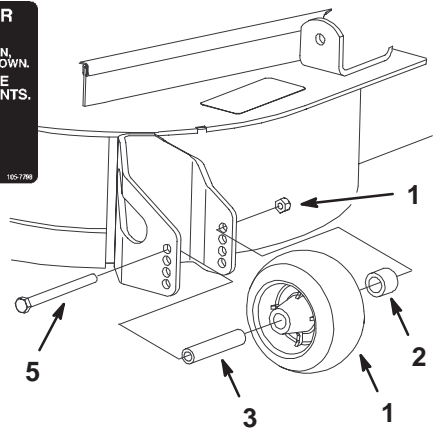

Figure 19

1. Anti-scalp roller
2. Bushing
3. Flange Nut
4. Bolt

ANTI-SCALP ROLLER ADJUSTMENT
 FOR MAXIMUM DECK FLOTATION
 PLACE ROLLERS IN POSITIONS SHOWN.
 TURN ENGINE OFF BEFORE
 MAKING ROLLER ADJUSTMENTS.

- 1.5" / 38mm
- 2.0" / 51mm
- 2.5" / 63mm
- 3.0" / 76mm



m-6844

Figure 20

- 1. Anti-scalp roller
- 2. Spacer
- 3. Bushing
- 4. Flange Nut
- 5. Bolt

Adjusting the Flow Baffle

The mower discharge flow can be adjusted for different types of mowing conditions. Position the cam locks and baffle to give the best quality of cut.

1. To adjust the cam locks, swing the lever up to loosen the cam lock (Fig. 25).
2. Adjust the baffle and cam locks in the slots to the desired discharge flow.
3. Swing the lever back over to tighten the baffle and cam locks.
4. If the cams do not lock the baffle into place or it is too tight, loosen the lever and then rotate the cam lock. Adjust the cam lock until the desired locking pressure is achieved.

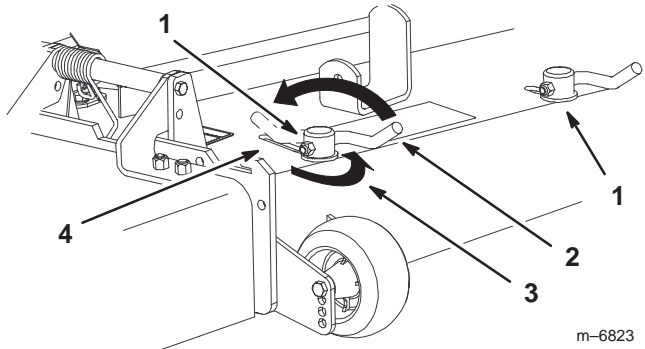

m-6823

Figure 21

- 1. Cam lock
- 2. Lever
- 3. Rotate cam to increase or decrease locking pressure
- 4. Slot

Positioning the Flow Baffle

The following figures are only recommendations for use. Adjustments will vary by grass type, moisture content, and height of grass.

Note: If the engine power draws down and the mower ground speed is the same, open up the baffle.

Position A

This is the full rear position. The suggested use for this position is as follows.

- Use for short, light grass mowing conditions.
- Use in dry conditions.
- For smaller grass clippings.
- Propels grass clippings farther away from the mower.

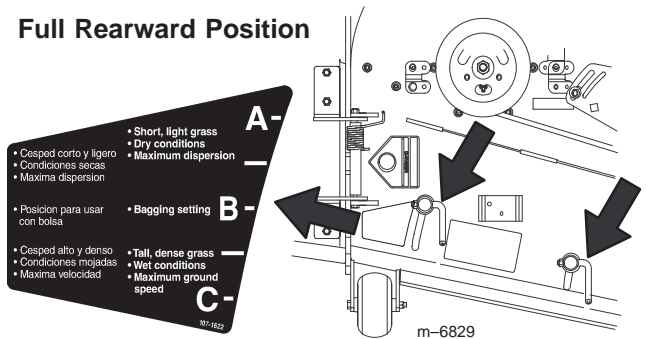

m-6829

Figure 22

Position B

Use this position when bagging.

Middle Position

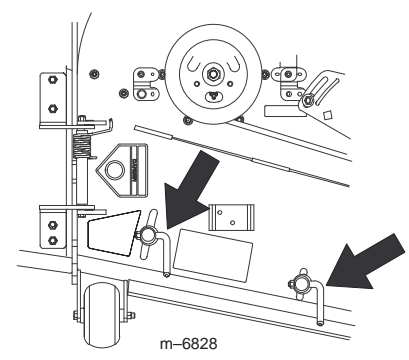

m-6828

Figure 23

Position C

This is the full open position. The suggested use for this position is as follows.

- Use in tall, dense grass mowing conditions.
- Use in wet conditions.
- Lowers the engine power consumption.
- Allows increased ground speed in heavy conditions.
- This position is similar to the benefits of the Toro SFS mower.

Full Forward Position

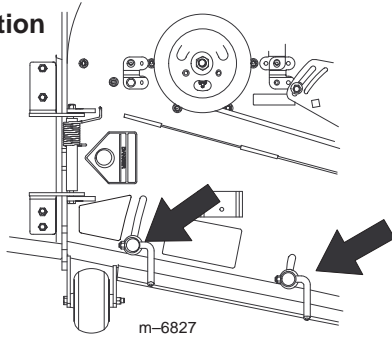

Figure 24

Positioning the Seat

The seat can move forward and backward. Position the seat where you have the best control of the machine and are most comfortable.

1. To adjust, move the lever sideways to unlock the seat (Fig. 25).
2. Slide the seat to the desired position and release the lever to lock it in position.

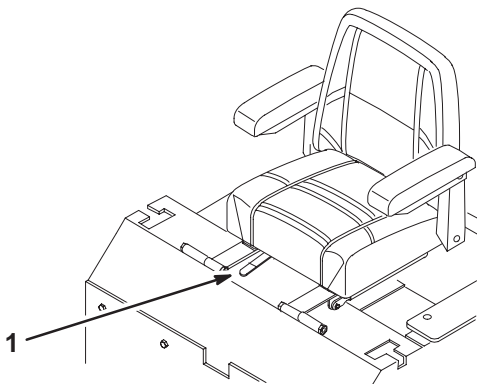

Figure 25

1. Adjustment lever

Unlatching the Seat

Push the seat latch rearward to unlatch the seat. This will allow access to the machine under the seat.

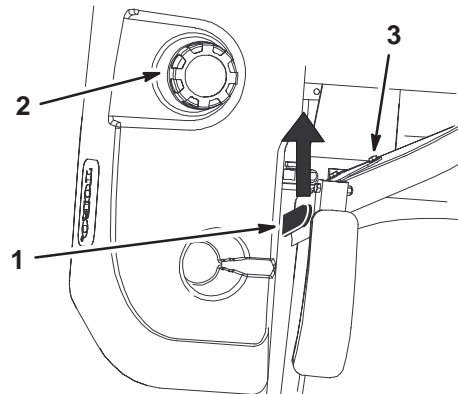

Figure 26

1. Seat latch
2. Gas cap
3. Seat

Pushing the Machine by Hand

Important Always push the machine by hand. Never tow the machine because hydraulic damage may occur.

Pushing the Machine

1. Disengage the power take off (PTO) and turn the ignition key to off. Move levers to neutral locked position and apply parking brake. Remove the key.
2. Rotate the by-pass valves counterclockwise 1 turn to push. This allows hydraulic fluid to by-pass the pump enabling the wheels to turn (Fig. 27).

Important Do not rotate by-pass valves more than 1 turn. This prevents valves from coming out of the body and causing fluid to run out.

3. Disengage the parking brake before pushing.

Changing to Machine Operation

1. Rotate the by-pass valves clockwise 1 turn to operate machine (Fig. 27).

Note: Do not over tighten the by-pass valves.

Note: The machine will not drive unless the by-pass valves are turned in.

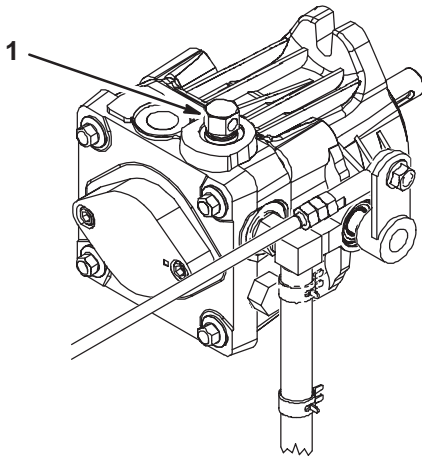

m-6124

Figure 27
By-pass valve

Using the Side Discharge

The mower has a hinged grass deflector that disperses clippings to the side and down toward the turf.



Danger



Without the grass deflector, discharge cover, or complete grass catcher assembly mounted in place, you and others are exposed to blade contact and thrown debris. Contact with rotating mower blade(s) and thrown debris will cause injury or death.

- Never remove the grass deflector from the mower because the grass deflector routes material down toward the turf. If the grass deflector is ever damaged, replace it immediately.
- Never put your hands or feet under the mower.
- Never try to clear the discharge area or mower blades unless you move the power take off (PTO) to the off position, rotate the ignition key to off and remove the key.
- Make sure the grass deflector is in the down position.

Transporting Machines

Use a heavy-duty trailer or truck to transport the machine. Ensure that the trailer or truck has all necessary lighting and marking as required by law. Please carefully read all the safety instructions. Knowing this information could help you, your family, pets or bystanders avoid injury.

To transport the machine:

- Lock the brake and block the wheels.
- Securely fasten the machine to the trailer or truck with straps, chains, cable, or ropes.
- Secure a trailer to the towing vehicle with safety chains.



Warning



Driving on street or roadway without turn signals, lights, reflective markings, or a slow moving vehicle emblem is dangerous and can lead to accidents causing personal injury.

Do not drive machine on a public street or roadway.

Loading Machines

Use extreme caution when loading units on trailers or trucks. One full width ramp that is wide enough to extend beyond the rear tires is recommended instead of individual ramps for each side of the unit (Fig. 28). The lower rear section of the tractor frame extends back between the rear wheels and serves as a stop for tipping backward. Having a full width ramp provides a surface for the frame members to contact if the unit starts to tip backward. If it is not possible to use one full width ramp, use enough individual ramps to simulate a full width continuous ramp.

The ramp should be long enough so that the angles do not exceed 15 degrees (Fig. 28). A steeper angle may cause mower mower components to get caught as the unit moves from ramp to trailer or truck. Steeper angles may also cause the unit to tip backward. If loading on or near a slope, position the trailer or truck so it is on the down side of the slope and the ramp extends up the slope. This will minimize the ramp angle. The trailer or truck should be as level as possible.

Important Do Not attempt to turn the unit while on the ramp; you may lose control and drive off the side.

Avoid sudden acceleration when driving up a ramp and sudden deceleration when backing down a ramp. Both maneuvers can cause the unit to tip backward.



Warning



Loading a unit onto a trailer or truck increases the possibility of backward tip-over and could cause serious injury or death.

- Use extreme caution when operating a unit on a ramp.
- Use only a single, full width ramp; *Do Not* use individual ramps for each side of the unit.
- If individual ramps must be used, use enough ramps to create an unbroken ramp surface wider than the unit.
- *Do not* exceed a 15 degree angle between ramp and ground or between ramp and trailer or truck.
- Avoid sudden acceleration while driving unit up a ramp to avoid tipping backward.
- Avoid sudden deceleration while backing unit down a ramp to avoid tipping backward.

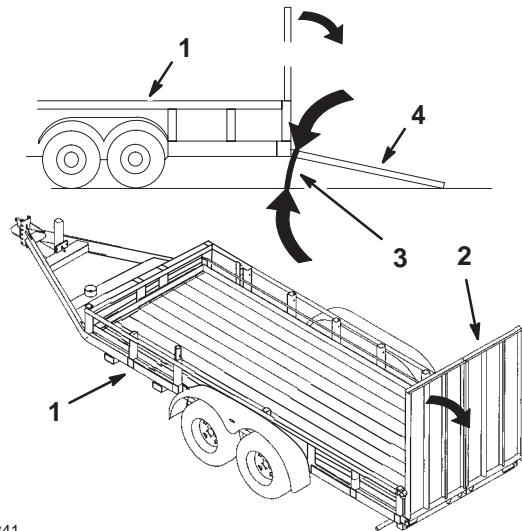

m-6841

Figure 28

- | | |
|--------------------------------|------------------------------|
| 1. Trailer | 4. Full width ramp—side view |
| 2. Full width ramp | |
| 3. Not greater than 15 degrees | |

Using the Z Stand

The Z Stand[®] is used for raising the front end of the machine. This allows for cleaning of the mower and removal of the blades.



Warning



Unit could fall onto someone and cause serious injury or death.

- Use extreme caution when operating unit on Z Stand.
- Use only for cleaning mower and removing blades.
- *Do not* keep unit on Z Stand for extended periods of time.
- Always turn the engine off, set the parking brake and remove the key before performing any maintenance to mower.

Driving up onto the Z Stand

Important Use the Z Stand on a level surface.

1. Raise the mower to the transport position.
2. Remove the bracket pin (Fig. 29).

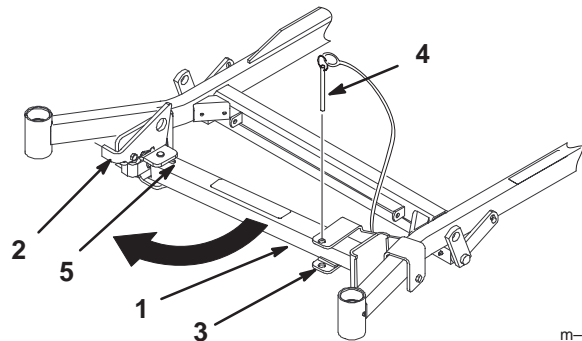

m-5599

Figure 29

- | | |
|------------|-------------------|
| 1. Z Stand | 4. Bracket Pin |
| 2. Latch | 5. Bottom of slot |
| 3. Bracket | |

3. Raise the latch. Swing the stand foot out front and slide stand toward machine, into the bottom of slot (Fig. 29 and 30).

- Set the foot of stand on the ground and rest the latch on the pivot tab (Fig. 30).

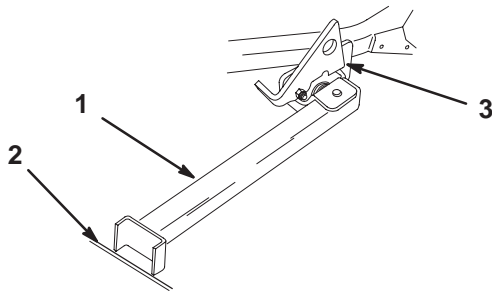

Figure 30

- Z Stand (Positioned in slot)
- Crack in side walk or turf
- Latch resting on pivot tab

m-5600

- Start the engine and put it at half throttle.

Note: For best results, place the foot of stand into seams in sidewalks or into the turf (Fig. 30).

- Drive onto the stand. Stop when the latch drops over the tab into the locked position (Fig. 30). Once onto the stand, engage the parking brake and turn off the engine.
- Chock or block the drive wheels.

! **Warning** !

Parking brake may not hold machine parked on Z Stand and could cause personal injury or property damage.

Do not park on Z Stand unless wheels are chocked or blocked.

- Perform the maintenance.

Driving off the Z Stand

- Remove the chocks or blocks.
- Raise the latch to the unlocked position (Fig. 31).
- Start the engine and place it at half throttle. Disengage the parking brake.
- Slowly drive backwards off of the stand.
- Return the stand to its rest position (Fig. 29).

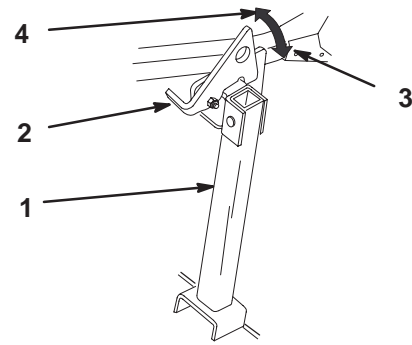

Figure 31

- Z Stand
- Latch
- Locked position
- Unlocked position

m-5601

Tips for Mowing Grass

Fast Throttle Setting

For best mowing and maximum air circulation, operate the engine at the fast throttle position. Air is required to thoroughly cut grass clippings, so do not set the height-of-cut so low as to totally surround the mower by uncut grass. Always try to have one side of the mower free from uncut grass, which allows air to be drawn into the mower.

Cutting a Lawn for the First Time

Cut grass slightly longer than normal to ensure the cutting height of the mower does not scalp any uneven ground. However, the cutting height used in the past is generally the best one to use. When cutting grass longer than six inches tall, you may want to cut the lawn twice to ensure an acceptable quality of cut.

Cut 1/3 of the Grass Blade

It is best to cut only about 1/3 of the grass blade. Cutting more than that is not recommended unless grass is sparse, or it is late fall when grass grows more slowly.

Mowing Direction

Alternate mowing direction to keep the grass standing straight. This also helps disperse clippings which enhances decomposition and fertilization.

Mow at Correct Intervals

Normally, mow every four days. But remember, grass grows at different rates at different times. So to maintain the same cutting height, which is a good practice, mow more often in early spring. As the grass growth rate slows

in mid summer, mow less frequently. If you cannot mow for an extended period, first mow at a high cutting height; then mow again two days later at a lower height setting.

Cutting Speed

To improve cut quality, use a slower ground speed in certain conditions.

Avoid Cutting Too Low

If the cutting width of the mower is wider than the mower you previously used, raise the cutting height to ensure that uneven turf is not cut too short.

Long Grass

If the grass is ever allowed to grow slightly longer than normal, or if it contains a high degree of moisture, raise the cutting height higher than usual and cut the grass at this setting. Then cut the grass again using the lower, normal setting.

When Stopping

If the machine's forward motion must be stopped while mowing, a clump of grass clippings may drop onto your lawn. To avoid this, move onto a previously cut area with the blades engaged.

Keep the Underside of the Mower Clean

Clean clippings and dirt from the underside of the mower after each use. If grass and dirt build up inside the mower, cutting quality will eventually become unsatisfactory.

Blade Maintenance

Maintain a sharp blade throughout the cutting season because a sharp blade cuts cleanly without tearing or shredding the grass blades. Tearing and shredding turns grass brown at the edges, which slows growth and increases the chance of disease. Check the cutter blades daily for sharpness, and for any wear or damage. File down any nicks and sharpen the blades as necessary. If a blade is damaged or worn, replace it immediately with a genuine TORO replacement blade.

Maintenance

Recommended Maintenance Schedule

Maintenance Service Interval	Maintenance Procedure
After first 5 hours	<ul style="list-style-type: none"> Hydraulic fluid—check level Hydraulic filter—change
Each Use	<ul style="list-style-type: none"> Oil—check level Safety System—check Mower Housing—clean Engine air intake—clean¹
Every 8 Hours	<ul style="list-style-type: none"> Cutting Blades—check
Every 25 Hours	<ul style="list-style-type: none"> Idler arm—grease Traction belt idler arm—grease Brake lever—grease Mower support arms—grease Linkage bushings—oil¹ Hydraulic fluid—check level Battery—check electrolyte Blade Spindle Bearings—grease
Every 50 Hours	<ul style="list-style-type: none"> Belts—adjust tension Belts—check for wear/cracks Tires—check pressure
Every 100 Hours	<ul style="list-style-type: none"> Engine Oil—change¹ Hydraulic lines—check Engine Cooling System—clean¹
Every 200 Hours	<ul style="list-style-type: none"> Oil Filter—change (200 hours or every other oil change)¹ Hydraulic filter—change Spark Plug(s)—check Fuel Filter—replace Brake pivot—grease
Every 250 Hours	<ul style="list-style-type: none"> Replace or clean primary air cleaner filter¹ Safety air cleaner¹— check
Every 500 Hours or at Storage	<ul style="list-style-type: none"> Caster Pivot— adjustment Wheel Hub Slotted Nut— adjustment
Every 600 Hours or at Storage	<ul style="list-style-type: none"> Safety air cleaner¹— replace
Before Storage Service	<ul style="list-style-type: none"> Battery—charge, Disconnect cables Gasoline—drain Chipped Surfaces—paint Perform all maintenance procedures listed above before storage

¹More often in dusty, dirty conditions

Important Refer to your engine operator's manual for additional maintenance procedures.



Caution



If you leave the key in the ignition switch, someone could accidentally start the engine and seriously injure you or other bystanders.

Remove the key from the ignition and disconnect the wire from the spark plug(s) before you do any maintenance. Set the wire aside so that it does not accidentally contact the spark plug.

Servicing the Cutting Blades

Maintain sharp blades throughout the cutting season because sharp blades cut cleanly without tearing or shredding the grass blades. Tearing and shredding turns grass brown at the edges, which slows growth and increases the chance of disease.

Check the cutter blades daily for sharpness, and for any wear or damage. File down any nicks and sharpen the blades as necessary. If a blade is damaged or worn, replace it immediately with a genuine TORO replacement blade. For convenient sharpening and replacement, you may want to keep extra blades on hand.



Danger



A worn or damaged blade can break, and a piece of the blade could be thrown into the operator's or bystander's area, resulting in serious personal injury or death.

- Inspect the blade periodically for wear or damage.
- Replace a worn or damaged blade.

Before Inspecting or Servicing the Blades

Disengage the blade control (PTO) and set the parking brake. Turn the ignition key to off. Remove the key and disconnect the spark plug wire(s) from the spark plug(s).

Inspecting the Blades

1. Inspect the cutting edges (Fig 32). If the edges are not sharp or have nicks, remove and sharpen the blades. Refer to Sharpening the Blades on page 31.
2. Inspect the blades, especially the curved area (Fig. 32). If you notice any damage, wear, or a slot forming in this area (item 3 in Fig. 32), immediately install a new blade.

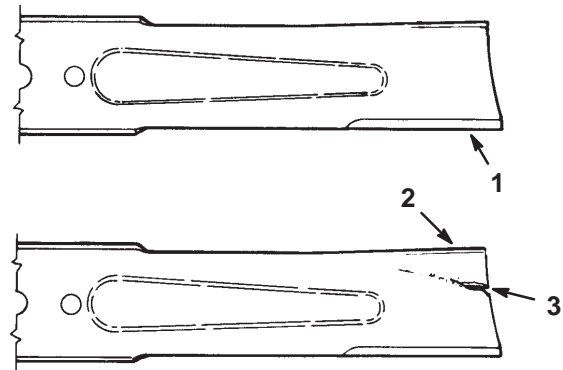

m-151

Figure 32

1. Cutting Edge
2. Curved Area
3. Wear/slot Forming

Checking for Bent Blades

1. Rotate the blades until the ends face forward and backward (Fig. 33). Measure from a level surface to the cutting edge, position A, of the blades (Fig. 34). Note this dimension.

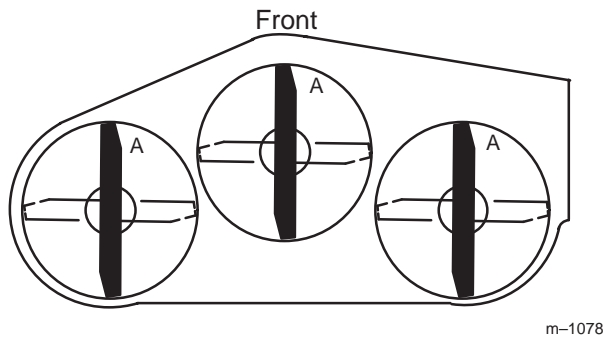

Figure 33

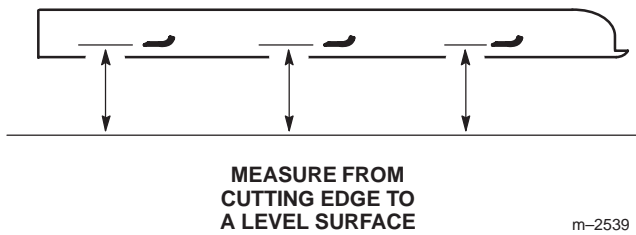

Figure 34

2. Rotate the opposite ends of the blades forward.
3. Measure from a level surface to the cutting edge of the blades at the same position as in step 1. The difference between the dimensions obtained in steps 1 and 2 must not exceed 1/8 inch (3 mm). If this dimension exceeds 1/8 inch (3 mm), the blade is bent and must be replaced. Refer to Removing the Blades and Installing the Blades.

Warning

A blade that is bent or damaged could break apart and could seriously injure or kill you or bystanders.

- Always replace bent or damaged blade with a new blade.
- Never file or create sharp notches in the edges or surfaces of blade.

Removing the Blades

Blades must be replaced if a solid object is hit, if the blade is out of balance or is bent. To ensure optimum performance and continued safety conformance of the machine, use genuine TORO replacement blades. Replacement blades made by other manufacturers may result in non-conformance with safety standards.

Warning

Contact with sharp blade can cause serious injury.

Wear gloves or wrap sharp edges of the blade with a rag.

1. Hold the blade end using a rag or thickly-padded glove. Remove the blade bolt, spring disk and blade from the spindle shaft (Fig. 37).

Sharpening the Blades

Warning

When sharpening blade, pieces of blade could be thrown and cause serious injury.

Wear proper eye protection when sharpening blade.

1. Use a file to sharpen the cutting edge at both ends of the blade (Fig. 35). Maintain the original angle. The blade retains its balance if the same amount of material is removed from both cutting edges.

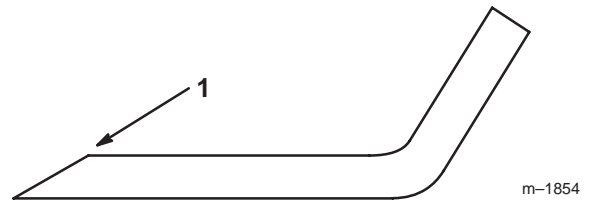

Figure 35

1. Sharpen at original angle

2. Check the balance of the blade by putting it on a blade balancer (Fig. 36). If the blade stays in a horizontal position, the blade is balanced and can be used. If the blade is not balanced, file some metal off the end of the sail area only (Fig. 37). Repeat this procedure until the blade is balanced.

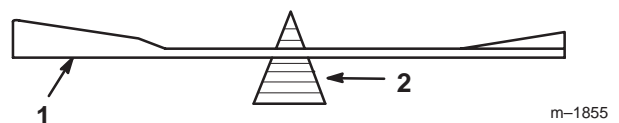

Figure 36

1. Blade
2. Balancer

Installing the Blades

1. Install the blade onto the spindle shaft (Fig. 37).

Important The curved part of the blade must be pointing upward toward the inside of the mower to ensure proper cutting.

2. Install the spring disk and blade bolt (Fig. 37). **Torque the blade bolt to 85–110 ft-lb (115–150 N m).**

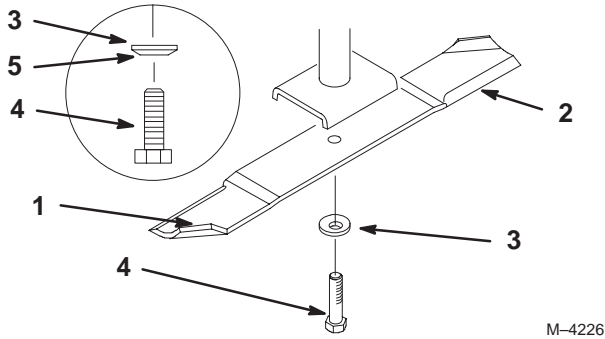

Figure 37

- | | |
|-----------------------|---------------------------|
| 1. Sail Area of Blade | 4. Blade Bolt |
| 2. Blade | 5. Cone Towards Bolt Head |
| 3. Spring Disk | |

Servicing the Air Cleaner

Foam Element: Clean after every 25 operating hours.

Paper Element: Clean after every 100 operating hours.
Replace after every 200 operating hours or yearly, whichever occurs first.

Note: Service the air cleaner more frequently (every few hours) if operating conditions are extremely dusty or sandy.

Removing the Foam and Paper Elements

1. Disengage the PTO, move the motion control levers to the neutral locked position and set the parking brake.
2. Stop the engine, remove the key, and wait for all moving parts to stop before leaving the operating position.

3. Clean around the air cleaner to prevent dirt from getting into the engine and causing damage. Unscrew the knob and remove the air cleaner cover (Fig. 38).

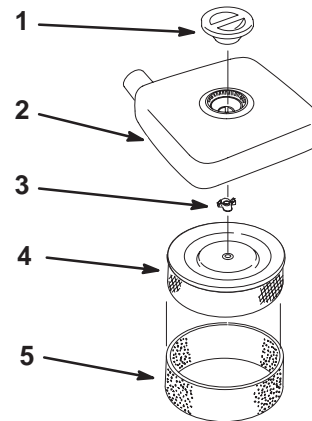

Figure 38

- | | |
|----------------------|------------------|
| 1. Knob | 4. Paper element |
| 2. Air cleaner cover | 5. Foam element |
| 3. Air cleaner nut | |

4. Carefully slide the foam element off the paper element (Fig. 38).
5. Unscrew the cover nut and remove the paper element (Fig. 38).

Cleaning the Foam Element

1. Wash the foam element in liquid soap and warm water. When the element is clean, rinse it thoroughly.
2. Dry the element by squeezing it in a clean cloth (do not wring).

Important Replace the foam element if it is torn or worn. Do not oil the foam element.

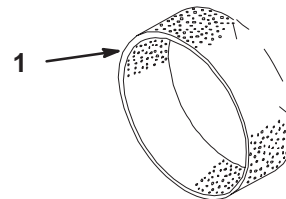

Figure 39

Foam element

Cleaning the Paper Element

1. Lightly tap the element on a flat surface to remove dust and dirt (Fig. 40).
2. Inspect the element for tears, an oily film, and damage to the rubber seal.

Important Never clean the paper element with pressurized air or liquids. Replace the paper element if it is damaged, or cannot be cleaned thoroughly.

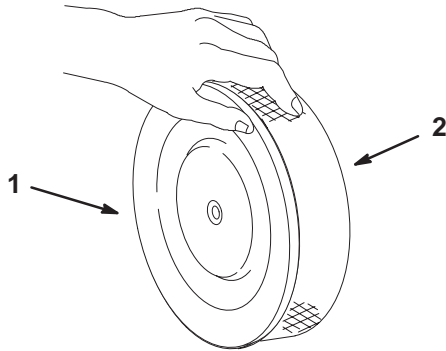

Figure 40

1. Paper element
2. Rubber seal

Installing the Foam and Paper Elements

Important To prevent engine damage, always operate the engine with the complete foam and paper air cleaner assembly installed.

1. Carefully slide the foam element onto the paper air cleaner element (Fig. 38).
2. Place the air cleaner assembly onto the air cleaner base (Fig. 38).
3. Install the air cleaner and secure with cover nut (Fig. 38).

Servicing the Engine Oil

Change oil:

- After the first 8 operating hours.
- After every 100 operating hours.

Note: Change oil more frequently when operating conditions are extremely dusty or sandy.

Oil Type: Detergent oil (API service SF, SG, SH or SJ)

Crankcase Capacity: with filter change, 57 oz. (1.7 l)
without filter change, 47 oz. (1.4 l)

Viscosity: See table below

USE THESE SAE VISCOSITY OILS

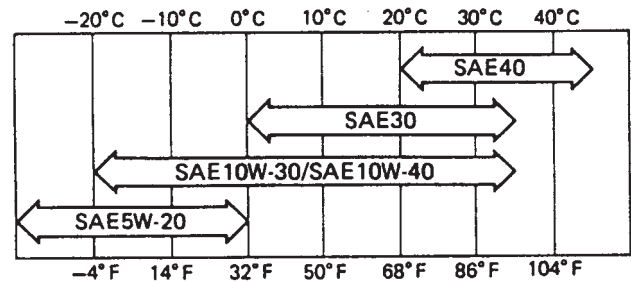

m-4292

Checking the Engine Oil Level

Note: Check the oil when the engine is cold.

1. Disengage the PTO, move the motion control levers to the neutral locked position and set the parking brake.
2. Stop the engine, remove the key, and wait for all moving parts to stop before leaving the operating position.
3. Clean around the oil dipstick (Fig. 41) so dirt cannot fall into engine.

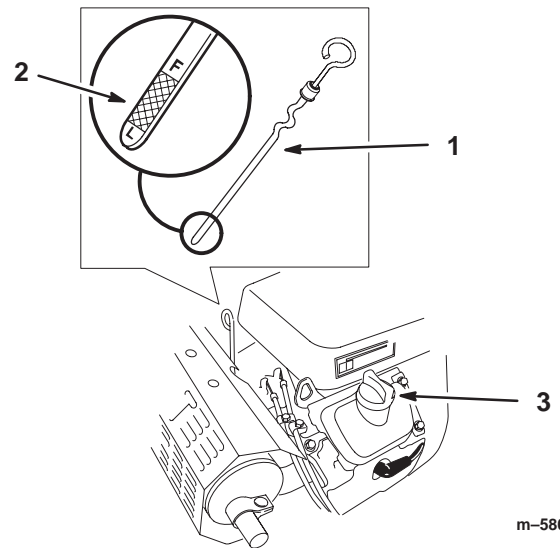

Figure 41

1. Oil dipstick
2. Metal end
3. Filler cap

4. Pull the oil dipstick and wipe the metal end clean (Fig. 41).
5. Slide the oil dipstick fully into the engine. Pull the dipstick out and look at the metal end (Fig. 41). If oil level is low, slowly pour only enough oil into the filler tube to raise the level to the full mark.

Important Do not overfill the crankcase with oil because the engine may be damaged. Do not run engine with oil below the low mark because the engine may be damaged.

Changing the Engine Oil

Note: A hose was included in loose parts. Use this hose to direct the engine oil into the drain pan. The hose may be cut to a desired length.

1. Start the engine and let it run five minutes. This warms the oil so it drains better.
2. Disengage the PTO, move the motion control levers to the neutral locked position and set the parking brake.
3. Stop the engine, remove the key, and wait for all moving parts to stop before leaving the operating position.
4. Clean around the oil dipstick (Fig. 41) so dirt cannot fall into engine.
5. Place the hose onto oil drain valve to direct oil into drain pan (Fig. 42).
6. Place a pan below the drain hose. Rotate the oil drain valve to allow the oil to drain (Fig. 42).
7. When the oil has drained completely, close the drain valve.
8. Remove the drain hose. Place the hose in a notable place for future use (Fig. 42).

Note: Dispose of the used oil at a recycling center.

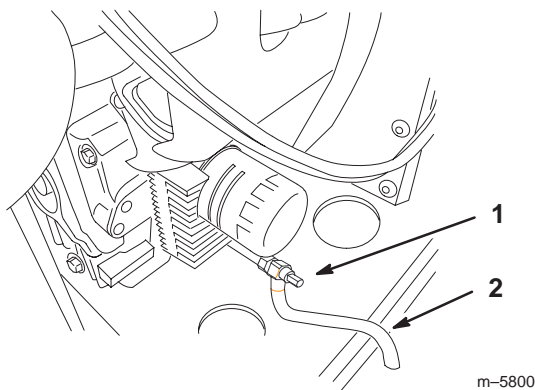

Figure 42

1. Oil drain valve
2. Drain hose

9. Slowly pour approximately 80% of the specified oil into the filler cap (Fig. 41). Refer to Servicing the Engine Oil, page 33.
10. Check the oil level; refer to Checking the Oil Level, page 33.
11. Slowly add additional oil to bring it to the full mark.

Change the Engine Oil Filter

Replace the oil filter every 200 hours or every other oil change.

Note: Change the oil filter more frequently when operating conditions are extremely dusty or sandy.

1. Drain the oil from the engine; refer to Changing the Oil, page 34.
2. Remove the old filter and wipe the filter adapter gasket surface (Fig. 43).
3. Pour new oil of the proper type in through the center hole. Stop pouring when the oil reaches the bottom of the threads. Allow a minute or two for the oil to be absorbed by filter material.
4. Apply a thin coat of new oil to the rubber gasket on the replacement filter (Fig. 43).

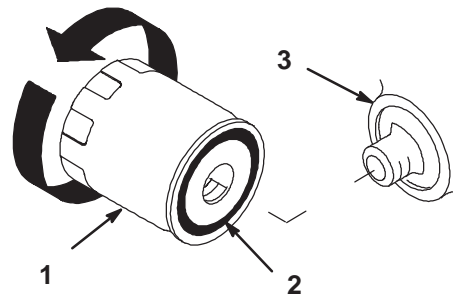

Figure 43

1. Oil filter
2. Gasket
3. Adapter

5. Install the replacement oil filter to the filter adapter. Turn the oil filter clockwise until the rubber gasket contacts the filter adapter, then tighten the filter an additional 1/2 turn (Fig. 43).
6. Fill the crankcase with the proper type of new oil; refer to Changing the Oil, page 34.

Servicing the Spark Plug

Check the spark plug(s) after every 100 operating hours. Make sure the air gap between the center and side electrodes is correct before installing the spark plug. Use a spark plug wrench for removing and installing the spark plug(s) and a gapping tool/feeler gauge to check and adjust the air gap. Install a new spark plug(s) if necessary.

Type: NGK® BPR4ES or equivalent
Air Gap: 0.030 inch (0.75 mm)

Removing the Spark Plug(s)

1. Disengage the PTO, move the motion control levers to the neutral locked position and set the parking brake.

2. Stop the engine, remove the key, and wait for all moving parts to stop before leaving the operating position.
3. Pull the wire(s) off the spark plug(s) (Fig. 44). Now clean around the spark plug(s) to prevent dirt from falling into the engine and potentially causing damage.
4. Remove the spark plug(s) and metal washer.

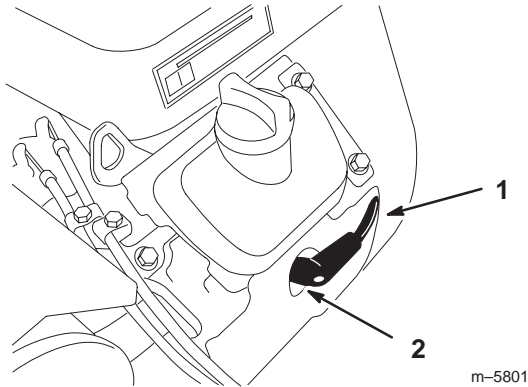

Figure 44

1. Spark plug wire
2. Spark plug

Checking the Spark Plug

1. Look at the center of the spark plug(s) (Fig. 45). If you see light brown or gray on the insulator, the engine is operating properly. A black coating on the insulator usually means the air cleaner is dirty.

Important Never clean the spark plug(s). Always replace the spark plug(s) when it has: a black coating, worn electrodes, an oily film, or cracks.

2. Check the gap between the center and side electrodes (Fig. 45). Bend the side electrode (Fig. 45) if the gap is not correct.

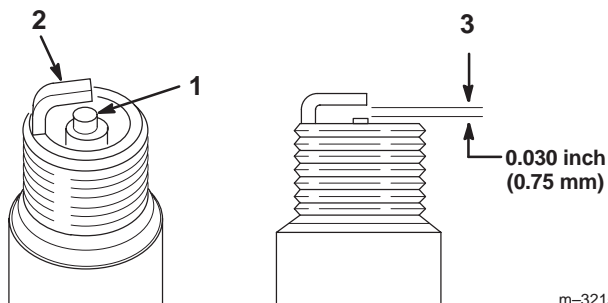

Figure 45

1. Center electrode insulator
2. Side electrode
3. Air gap (not to scale)

Installing the Spark Plug(s)

1. Install the spark plug(s). Make sure the air gap is set correctly.
2. Tighten the spark plug(s) to 16 ft.-lb. (22 N·m).
3. Push the wire(s) onto the spark plug(s) (Fig. 44).

Servicing the Fuel Filter

Replace the fuel filter after every 200 operating hours or yearly, whichever occurs first.

Replacing the Fuel Filter

Never install a dirty filter if it is removed from the fuel line.

1. Disengage the PTO, move the motion control levers to the neutral locked position and set the parking brake.
2. Stop the engine, remove the key, and wait for all moving parts to stop before leaving the operating position.
3. Allow the engine to cool down.
4. Close the fuel shut-off valve (Fig. 46).

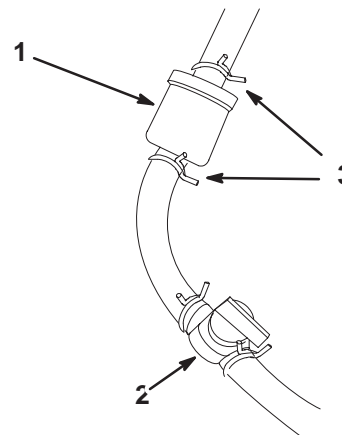

Figure 46

1. Filter
2. Fuel shut-off valve
3. Hose clamp

5. Squeeze the ends of the hose clamps together and slide them away from the filter (Fig. 46).
6. Remove the filter from the fuel lines.
7. Install a new filter and move the hose clamps close to the filter to secure the fuel line (Fig. 46).
8. Wipe up any spilled fuel.
9. Open the fuel shut-off valve.

Servicing the Fuel Tank

Draining The Fuel Tank

Danger

In certain conditions, gasoline is extremely flammable and highly explosive. A fire or explosion from gasoline can burn you and others and can damage property.

- Drain gasoline from the fuel tank when the engine is cold. Do this outdoors in an open area. Wipe up any gasoline that spills.
- Never smoke when draining gasoline, and stay away from an open flame or where a spark may ignite the gasoline fumes.

1. Disengage the PTO, move the motion control levers to the neutral locked position and set the parking brake.
2. Stop the engine, remove the key, and wait for all moving parts to stop before leaving the operating position.
3. Close fuel shut-off valve (Fig. 47).

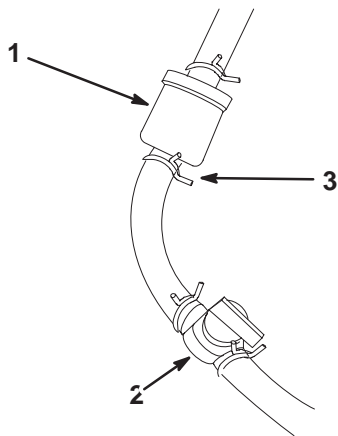

m-6843

Figure 47

- | | |
|------------------------|---------------|
| 1. Filter | 3. Hose clamp |
| 2. Fuel shut-off valve | |

4. Loosen the hose clamp at the fuel filter and slide it away from the fuel filter (Fig. 47).
5. Pull the fuel line off fuel filter (Fig. 47). Open fuel shut-off valve and allow gasoline to drain into a gas can or drain pan.

Note: Now is the best time to install a new fuel filter because the fuel tank is empty.

6. Install the fuel line onto the fuel filter. Slide the hose clamp close to the fuel filter to secure the fuel line (Fig. 47).

Greasing and Lubrication

Lubricate the machine when shown on the **Check Service Reference Aid** decal (Fig. 48). Grease more frequently when operating conditions are extremely dusty or sandy.

Grease Type: General-purpose grease.

How to Grease

1. Disengage the PTO, move the motion control levers to the neutral locked position and set the parking brake.
2. Stop the engine, remove the key, and wait for all moving parts to stop before leaving the operating position.
3. Clean the grease fittings with a rag. Make sure to scrape any paint off the front of the fitting(s).
4. Connect a grease gun to the fitting. Pump grease into the fittings until grease begins to ooze out of the bearings.
5. Wipe up any excess grease.

Greasing the Front Caster Pivots

Lubricate the front caster pivots once a year.

1. Remove the dust cap and adjust the caster pivots. Keep the dust cap off until greasing is done. Refer to Adjusting the Caster Pivot Bearing, page 39.
2. Remove the hex plug. Thread a grease zerk into the hole.
3. Pump grease into the zerk until it oozes out around the top bearing.
4. Remove the grease zerk in the hole. Install the hex plug and cap.

Where to Add Grease

Lubricate the grease fittings as shown on the **Check Service Reference Aid** decal (Fig. 48).

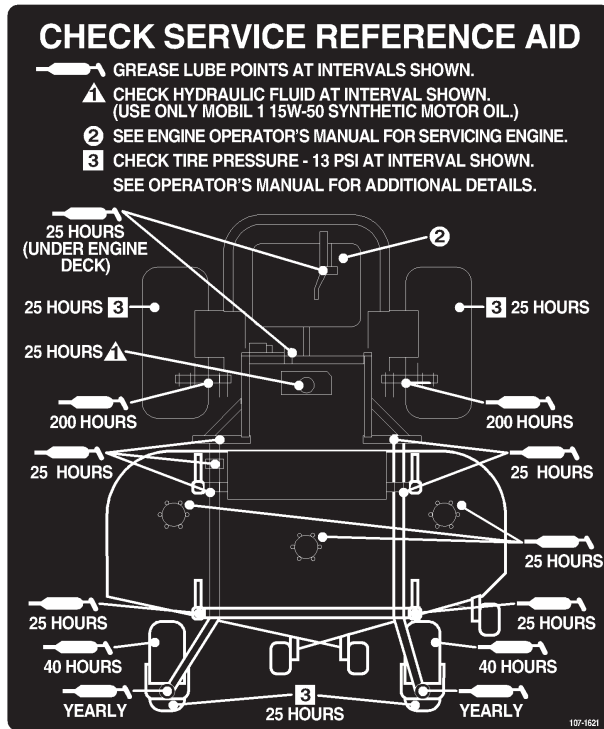

Figure 48

Where to Add Light Oil or Spray Lubrication

Lubricate the machine in the following areas with spray type lubricant or light oil. Lubricate every 160 hours.

- Seat switch actuator.
- Brake handle pivot.
- Brake rod bushings.
- Motion control bronze bushings.

Greasing the Spindles

The cutting unit must be lubricated weekly or every 25 hours. Refer to the Service Interval Chart on page 29. Grease with No. 2 general purpose lithium base or molybdenum base grease.

Important Make sure cutting unit spindles are full of grease weekly.

1. Disengage the PTO, move the motion control levers to the neutral locked position and set the parking brake.
2. Stop the engine, remove the key, and wait for all moving parts to stop before leaving the operating position.
3. Grease the three spindle bearings under the pulleys until grease comes out the lower seals (Fig. 49).
4. Grease the fittings on the push arms (Fig. 49).

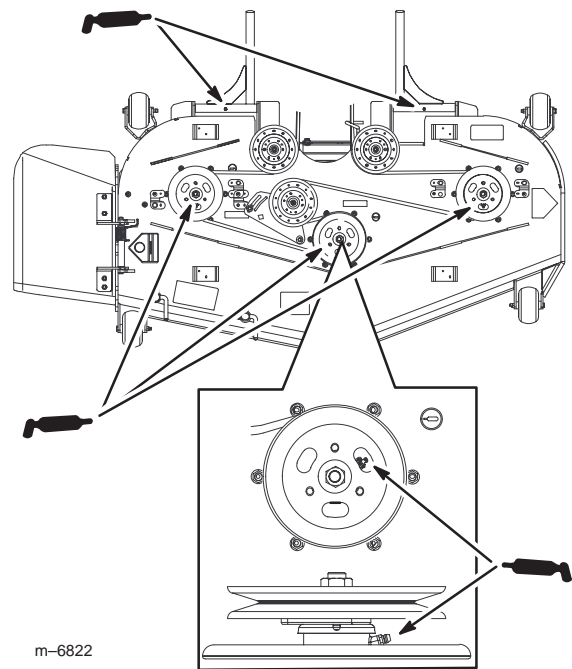
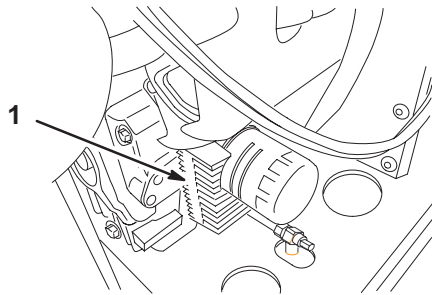

Figure 49

Cleaning the Cooling Systems

Cleaning the Engine Screen and the Oil Cooler

Before each use, check and clean engine screen and oil cooler. Remove any build-up of grass, dirt or other debris from the oil cooler screen and engine screen (Figures 50 and 51).



m-5800

Figure 50

1. Oil cooler

Cleaning the Engine Fins

Every 100 hours clean engine cylinder and cylinder head cooling fins. Also clean around carburetor, governor levers and linkage. This will make sure adequate cooling to hydraulic pumps, motors and engine and will reduce the possibility of overheating and mechanical damage.

1. Remove the engine shroud.
2. Clean the engine cooling fins.
3. Install the engine shroud.

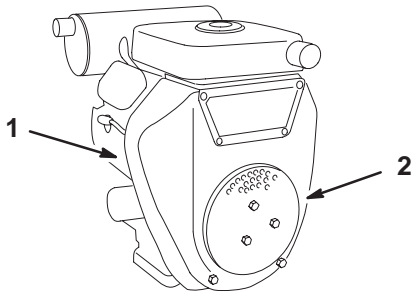

m-5806

Figure 51

1. Engine shroud
2. Engine screen

Checking the Tire Pressure

Maintain the air pressure in the front and rear tires as specified. Uneven tire pressure can cause uneven cut. Check the pressure at the valve stem after every 50 operating hours or monthly, whichever occurs first (Fig. 52). Check the tires when they are cold to get the most accurate pressure reading.

Pressure: 13 psi (90 kPa) drive wheels and caster wheels.

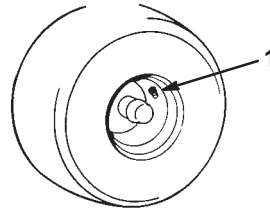

m-1872

Figure 52

1. Valve stem

Checking the Wheel Hub Slotted Nut

Check after every 500 operating hours.

The slotted nut needs to be torqued to 125 ft-lb (170 N·m).

1. Disengage the PTO, move the motion control levers to the neutral locked position and set the parking brake.
2. Stop the engine, remove the key, and wait for all moving parts to stop before leaving the operating position.
3. Remove the cotter pin.
4. Torque the slotted nut to 125 ft-lb (170 N·m) (Fig. 53).

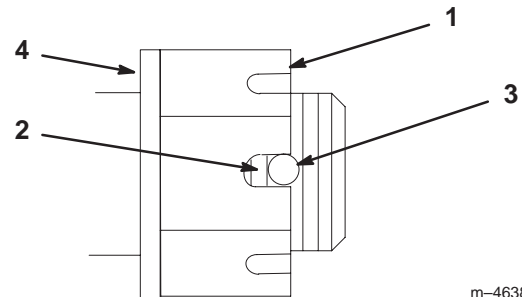

m-4638

Figure 53

1. Slotted Nut
2. Two threads or less showing
3. Hole in threaded rod
4. Washer (if needed)

5. Check the distance from bottom of slot in nut to inside edge of hole. Two threads or less should be showing (Fig. 53).

6. If more than two threads are showing remove nut and install washer between hub and nut (Fig. 53).
7. Torque the slotted nut to 125 ft–lb. (170 N·m) (Fig. 53).
8. Tighten nut until the next set of slots line up with the hole in the shaft (Fig. 53).
9. Replace cotter pin.

Adjusting the Caster Pivot Bearing

Check after every 500 operating hours or at storage, whichever comes first.

1. Disengage the PTO, move the motion control levers to the neutral locked position and set the parking brake.
2. Stop the engine, remove the key, and wait for all moving parts to stop before leaving the operating position.
3. Remove dust cap from caster and tighten lock nut (Fig. 54).
4. Tighten until spring washers are flat and then back off a 1/4 turn to properly set the pre-load on the bearings (Fig. 54).

Important Make sure spring washers are installed correctly as shown in figure 54.

5. Install the dust cap (Fig. 54).

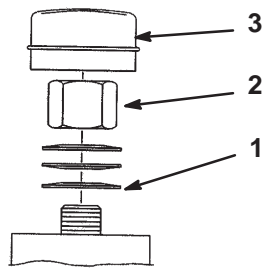

Figure 54

- | | |
|-------------------|-------------|
| 1. Spring Washers | 3. Dust Cap |
| 2. Lock Nut | |

Servicing the Hydraulic System

Checking the Hydraulic Fluid

Check the hydraulic fluid level:

- Before the engine is first started.
- After the first 8 operating hours.
- After every 25 operating hours.

Fluid Type: Mobil 1 15W-50 synthetic motor oil or equivalent synthetic oil.

Important Use oil specified or equivalent. Other fluids could cause system damage.

Hydraulic System Oil Capacity: 67 oz. (2.0 l)

Note: There are two ways of checking the hydraulic oil. One is when the oil is warm and one is when the oil is cold. The baffle inside the tank has two levels depending if the oil is warm or cold.

1. Position machine on a level surface and set the parking brake.
2. Clean area around filler neck of hydraulic tank (Fig. 55).

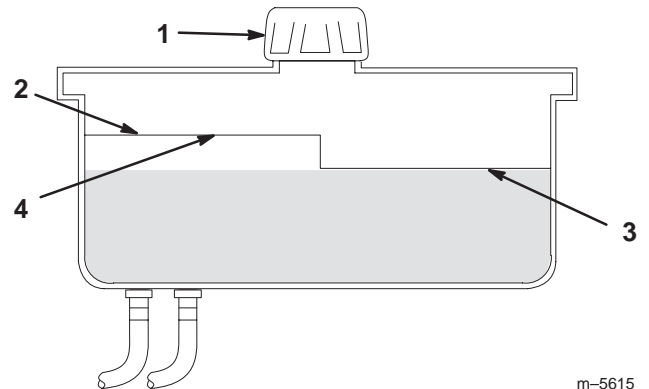

Figure 55

- | | |
|-----------|--------------------------|
| 1. Cap | 3. Cold fluid level—full |
| 2. Baffle | 4. Hot fluid level—full |

3. Remove the cap from the filler neck. Look inside to check if there is fluid in the reservoir (Fig. 55).
4. If there is no fluid, add fluid to the reservoir until it reaches the **cold** level of the baffle.
5. Run the machine at low idle for 15 minutes to allow any air to purge out of the system and warm the fluid. Refer to Starting and Stopping the Engine on page 19.
6. Recheck the fluid level while the fluid is warm. The fluid should be between cold and hot.
7. If required, add fluid to the hydraulic tank.

Note: The fluid level should be to the top of the **hot** level of the baffle, when the fluid is hot (Fig. 55).

8. Install the cap onto the filler neck.



Warning



Hydraulic fluid escaping under pressure can penetrate skin and cause injury.

- If hydraulic fluid is injected into the skin it must be surgically removed within a few hours by a doctor familiar with this type of injury. Gangrene may result if this is not done.
- Keep body and hands away from pin hole leaks or nozzles that eject high pressure hydraulic fluid.
- Use cardboard or paper to find hydraulic leaks.
- Safely relieve all pressure in the hydraulic system before performing any work on the hydraulic system.
- Make sure all hydraulic fluid hoses and lines are in good condition and all hydraulic connections and fittings are tight before applying pressure to hydraulic system.

Replacing the Hydraulic Filter

Change the hydraulic filter:

- After the first 8 operating hours.
- After every 200 operating hours.

Use summer filter above 32°F (0°C)

Use winter filter below 32°F (0°C)

1. Disengage the PTO, move the motion control levers to the neutral locked position and set the parking brake.
2. Stop the engine, remove the key, and wait for all moving parts to stop before leaving the operating position.

Important Do not substitute automotive oil filter or severe hydraulic system damage may result.

3. Place drain pan under filter, remove the old filter and wipe the filter adapter gasket surface clean (Fig. 56).

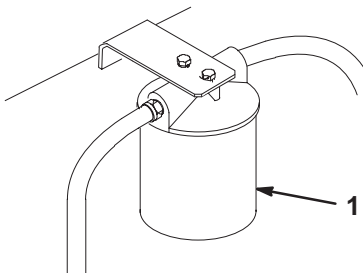

M-4763

Figure 56

Hydraulic filter

4. Apply a thin coat hydro fluid to the rubber gasket on the replacement filter (Fig. 57).
5. Install the replacement hydraulic filter onto the filter adapter. Do not tighten.
6. Fill the hydraulic tank with hydraulic fluid until the fluid overflows the filter and then turn the oil filter clockwise until the rubber gasket contacts the filter adapter, then tighten the filter an additional 1/2 turn (Fig. 57).
7. Clean up any spilled fluid.
8. Add fluid to the cold level of the baffle in the hydraulic tank.
9. Start the engine and let it run for about two minutes to purge air from the system. Stop the engine and check for leaks. If one or both wheels will not drive, refer Bleeding Hydraulic System, page 40.
10. Recheck the fluid level while the fluid is warm. The fluid should be between cold and hot.
11. If required, add fluid to the hydraulic tank. **Do not overfill.**

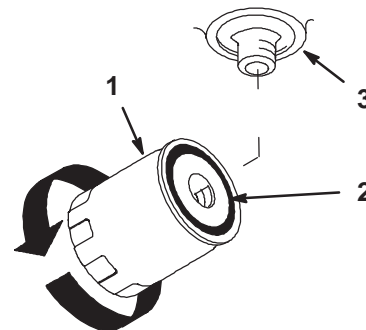

m-1256

Figure 57

1. Hydraulic filter
2. Gasket
3. Adapter

Bleeding the Hydraulic System

The traction system is self bleeding, however, it may be necessary to bleed the system if fluid is changed or after work is performed on the system.

1. Raise rear of the machine so wheels are off the ground and support with jack stands.
2. Start the engine and run at low idle speed. Engage the lever and traction on one side and spin the wheel by hand.
3. When the wheel begins to spin on its own, keep it engaged until wheel drives smoothly. (minimum 2 minutes)
4. Check hydraulic fluid level and add as required to maintain proper level.

- Repeat this procedure on the opposite wheel.

Checking the Hydraulic Lines

After every 100 operating hours, check hydraulic lines and hoses for leaks, loose fittings, kinked lines, loose mounting supports, wear, weather and chemical deterioration. Make necessary repairs before operating.

Note: Keep areas around hydraulic system clean from grass and debris build up.

! **Warning** !

Hydraulic fluid escaping under pressure can penetrate skin and cause injury.

- **If hydraulic fluid is injected into the skin it must be surgically removed within a few hours by a doctor familiar with this type of injury. Gangrene may result if this is not done.**
- **Keep body and hands away from pin hole leaks or nozzles that eject high pressure hydraulic fluid.**
- **Use cardboard or paper to find hydraulic leaks.**
- **Safely relieve all pressure in the hydraulic system before performing any work on the hydraulic system.**
- **Make sure all hydraulic fluid hoses and lines are in good condition and all hydraulic connections and fittings are tight before applying pressure to hydraulic system.**

Adjusting the Handle Neutral

If motion control levers do not align, or move easily into the console notch, adjustment is required. Adjust each lever, spring and rod separately.

Note: Motion control levers must be installed correctly. See Installing the Motion Control Levers in the set up instructions.

1. Disengage the PTO, move the motion control levers to the neutral locked position and set the parking brake.
2. Stop the engine, remove the key, and wait for all moving parts to stop before leaving the operating position.
3. Unlatch the seat and tilt the seat forward.
4. Begin with either the left or right motion control lever.
5. Move the lever to the neutral position but **not locked** (Fig. 59).
6. Pull lever back until the clevis pin (on arm below pivot shaft) contacts the end of the slot (just beginning to put pressure on the spring) (Fig. 59).
7. Check where the control lever is relative to notch in console (Fig. 58). It should be centered allowing lever to pivot outward to the neutral lock position.

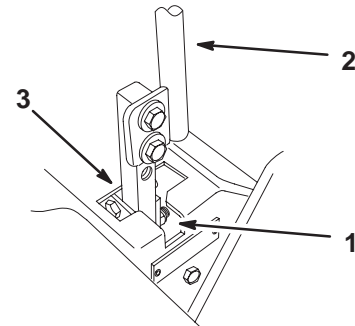

m-6282

Figure 58

1. Neutral locked position
2. Control lever
3. Neutral position

8. If adjustment is needed, loosen the nut and jam nut against the yoke (Fig. 59).
9. Apply slight rearward pressure on the motion control lever, turn the head of the adjustment bolt in the appropriate direction until the control lever is centered in neutral lock position (Fig. 58).

Note: Keeping rearward pressure on the lever will keep the pin at the end of the slot and allow the adjustment bolt to move the lever to the appropriate position.

10. Tighten the nut and jam nut (Fig. 59).
11. Repeat on the opposite side of the machine.

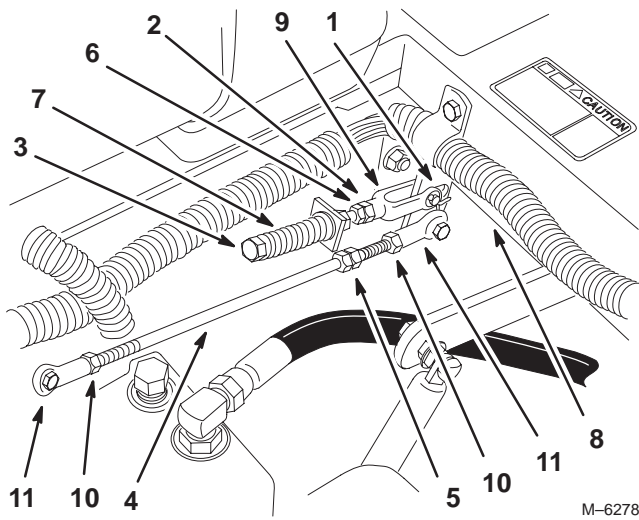

Figure 59

- | | |
|-----------------------|----------------|
| 1. Clevis pin in slot | 7. Spring |
| 2. Nut against yoke | 8. Pivot shaft |
| 3. Adjustment bolt | 9. Yoke |
| 4. Pump rod | 10. Locknut |
| 5. Double nuts | 11. Ball joint |
| 6. Jam Nut | |

Setting the Hydraulic Pump Neutral

Note: Adjust the handle neutral first. That has to be correct before the following adjustment can be made.

Danger

Mechanical or hydraulic jacks may fail to support machine and cause a serious injury.

- Use jack stand when supporting machine.
- Do not use hydraulic jacks.

Warning

Engine must be running so motion control adjustment can be performed. Contact with moving parts or hot surfaces may cause personal injury.

Keep hands, feet, face, clothing and other body parts away from rotating parts, muffler and other hot surfaces.

This adjustment must be made with the drive wheels turning.

1. Raise the frame and use jack stands to hold up the machine so drive wheels can rotate freely.
2. Unlatch the seat, tilt the seat forward and disconnect electrical connector from the seat safety switch.
3. **Temporarily** install a jumper wire across terminals in the wiring harness connector.
4. Slide the seat forward, disconnect the prop rod and tilt the seat fully forward.

Setting the Right-hand Hydraulic Pump Neutral

1. Start the engine, open the throttle 1/2 way and release parking brake. Refer to Starting and Stopping the Engine, page 19.

Note: The motion control lever must be in neutral while making any adjustments.

2. Adjust the pump rod length by rotating the knob, in the appropriate direction, until the wheel is still or slightly creeping in reverse (Fig. 60).
3. Move the motion control lever forward and reverse, then back to neutral. The wheel must stop turning or slightly creep in reverse.
4. Open the throttle to fast. Make sure the wheel remains stopped or slightly creeps in reverse, adjust if necessary.

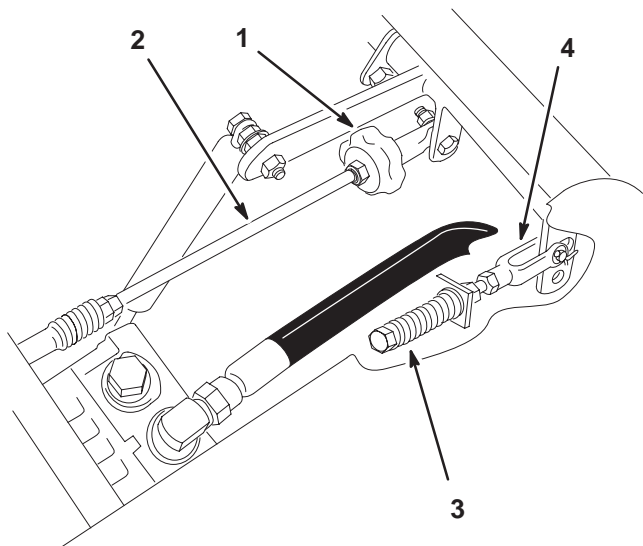

Figure 60

- | | |
|------------------|--------------------|
| 1. Tracking knob | 3. Adjustment bolt |
| 2. Pump rod | 4. Yoke |

Setting the Left-hand Hydraulic Pump Neutral

1. Loosen the locknuts at the ball joints on pump control rod (Fig. 59).
2. Start the engine, open throttle 1/2 way and release parking brake. Refer to Starting and Stopping the Engine, page 19.

Note: The motion control lever must be in neutral while making any adjustments.

Note: The front nut on the pump rod has left-hand threads.

3. Adjust the pump rod length by rotating double nuts on rod, in the appropriate direction, until wheel is still or slightly creeps in reverse (Fig. 59).
4. Move the motion control lever forward and reverse, then back to neutral. The wheel must stop turning or slightly creep in reverse.
5. Open the throttle to fast. Make sure the wheel remains stopped or slightly creeps in reverse, re-adjust if necessary.
6. Tighten the locknuts at the ball joints (Fig. 59).

⚠
Warning
⚠

Electrical system will not perform proper safety shut off with jumper wire installed.

- **Remove jumper wire from wire harness connector and plug connector into seat switch when adjustment is completed.**
- **Never operate this unit with jumper installed and seat switch bypassed.**

7. After both pump neutrals are set, shut off the machine.
8. Remove the jumper wire from the wire harness connector and plug the connector into the seat switch.
9. Install the seat rod and lower the seat into position.
10. Remove the jack stands.

Adjusting the Tracking

The right hand pump has a knob for adjusting the tracking.

Important Adjust the handle neutral and hydraulic pump neutral before adjusting the tracking. Refer to Adjusting the Handle Neutral on page 41 and Adjusting the Hydraulic Pump Neutral on page 42.

1. Push both control levers forward the same distance.

2. Check if the machine pulls to one side. If it does, stop the machine and set the parking brake.
3. Unlatch the seat and tip the seat up to access the tracking knob.

Note: Determine the left and right sides of the machine from the normal operating position.

4. To make the machine go right, turn the knob towards the rightside of the machine. Refer to figure 61.
5. To make the machine go left, turn the knob towards the leftside of the machine. Refer to figure 61.
6. Repeat this adjustment until the tracking is correct.

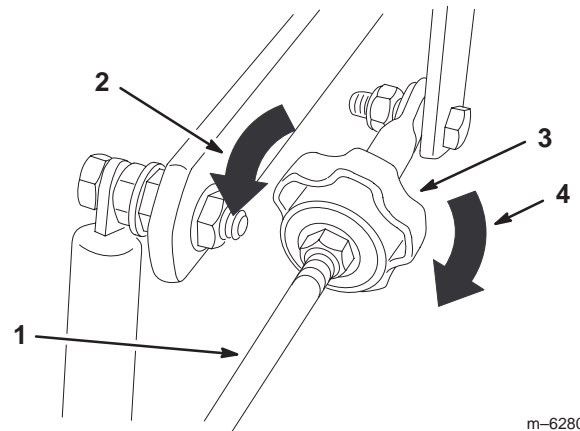

Figure 61

- | | |
|--------------------------------|---------------------------------|
| 1. Pump rod | 3. Tracking knob |
| 2. Turn this way to track left | 4. Turn this way to track right |

Replacing the Pump Drive Belt

Check pump drive belt for wear after every 50 hours of operation.

1. Pull the spring loaded idler down and remove traction belt from the engine and hydro pump pulleys (Fig. 62). Remove belt between pulleys.

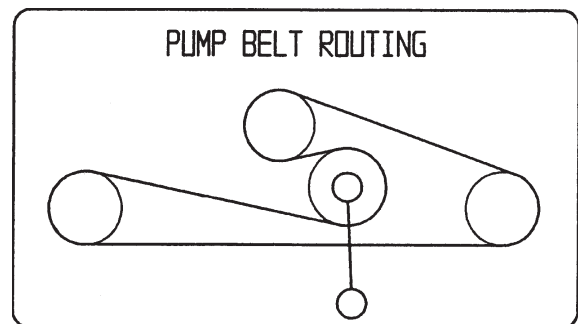

Figure 62

2. Install new belt around engine and hydro pump pulleys (Fig. 62).
3. Pull spring loaded idler down and align below traction belt. Release pressure on spring loaded idler (Fig. 62).

Adjusting the Parking Brake

Check parking brake for proper adjustment.

1. Disengage brake lever (lever down).
2. Measure the length of the spring. Measurement should be 2-3/4 inch (70 mm) between washers (Fig. 63).
3. If adjustment is necessary, loosen the jam nut below the spring and tighten the nut directly below the yoke (Fig. 63). Turn the nut until the correct measurement is obtained. Tighten the two nuts together and repeat on opposite side of unit.
4. Turn nuts clockwise to shorten spring length and turn counter-clockwise to lengthen the spring.
5. Engage parking brake, lever up.
 - A. Measure the distance between the trunnion roller and the collar on brake rod. The measurement should be 3/16-1/4 inch (5-7 mm) (Fig. 63).
6. If adjustment is necessary, loosen the jam nut directly below the yoke. Turn the bottom rod until the correct measurement is obtained (Fig. 63). Tighten jam nut at yoke

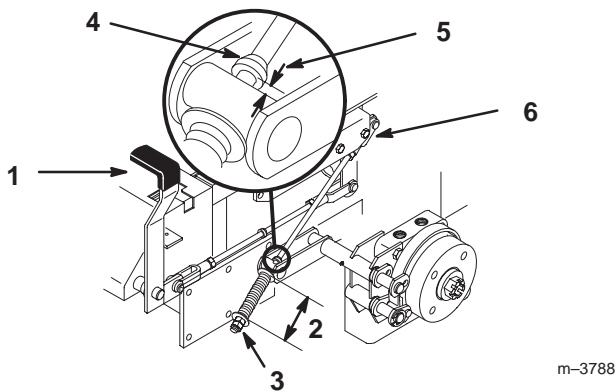

Figure 63

- | | |
|-----------------------------|---------------------------|
| 1. Brake lever | 4. Collar on brake rod |
| 2. Spring 2.75 inch (70 mm) | 5. 3/16-1/4 inch (5-7 mm) |
| 3. Adjusting nuts | 6. Jam nut and yoke |

Servicing the Fuse

Service Interval/Specification

The electrical system is protected by fuses. It requires no maintenance, however, if a fuse blows check component/circuit for malfunction or short.

Fuse: Main F1-30 amp, blade-type
Alternator F2-25 amp, blade-type

1. Unlatch the seat and raise the seat to gain access to fuse holder (Fig. 64).
2. To replace fuses pull out on the fuse to remove it
3. Install a new fuse (Fig. 64).

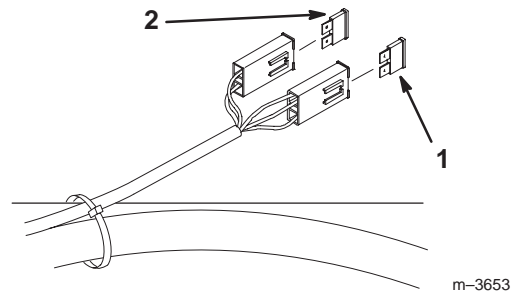

Figure 64

1. Main-30 amp
2. Alternator-25 amp

Servicing the Battery



Warning



Battery posts, terminals, and related accessories contain lead and lead compounds, chemicals known to the State of California to cause cancer and reproductive harm. *Wash hands after handling.*

Checking Electrolyte Level

1. With the engine off, open the hood to locate the battery.
2. Look at the side of the battery. The electrolyte must be up to the **upper** line (Fig. 65). Do not allow the electrolyte to get below the **lower** line (Fig. 65).

- If the electrolyte is low, add the required amount of distilled water; refer to Adding Water to the Battery, page 46.

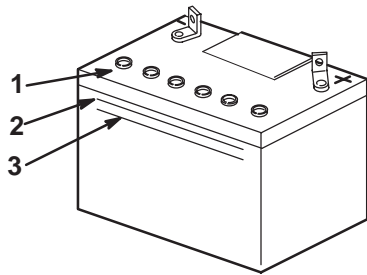

Figure 65

1. Filler caps
2. Upper line
3. Lower line

m-5004

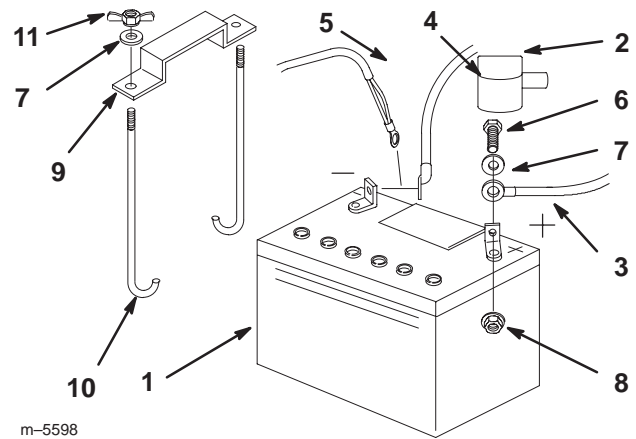

Figure 66

1. Battery
2. Terminal boot
3. Positive battery cable
4. Negative battery cable
5. Ground wire
6. Bolt, 1/4 x 3/4 inch
7. Washer, 1/4 inch
8. Locknut, 1/4 inch
9. Battery clamp
10. J-bolts
11. Wing nut, 1/4 inch

Removing the Battery

! **Danger** !

Battery electrolyte contains sulfuric acid which is a deadly poison and causes severe burns.

- Do not drink electrolyte and avoid contact with skin, eyes or clothing. Wear safety glasses to shield your eyes and rubber gloves to protect your hands.
- Fill the battery where clean water is always available for flushing the skin.
- Follow all instructions and comply with all safety messages on the electrolyte container.

! **Warning** !

Battery terminals or metal tools could short against metal machine components causing sparks. Sparks can cause the battery gasses to explode, resulting in personal injury.

- When removing or installing the battery, do not allow the battery terminals to touch any metal parts of the machine.
- Do not allow metal tools to short between the battery terminals and metal parts of the machine.

Installing the Battery

- Position battery in tray with terminal posts toward the engine (Fig. 66).
- First, install the positive (red) battery cable to positive (+) battery terminal.
- Then install the negative battery cable and ground wire to the negative (-) battery terminal.
- Secure the cables with 2 bolts (1/4 x 3/4 inch), 2 washers (1/4 inch), and 2 locknuts (1/4 inch) (Fig. 66).
- Slide the red terminal boot onto the positive (red) battery post.
- Secure the battery with J-bolts, hold down clamp and 2 washers (1/4 inch), and 2 wing nuts (1/4 inch) (Fig. 66).

! **Warning** !

Incorrect battery cable routing could damage the machine and cables causing sparks. Sparks can cause the battery gasses to explode, resulting in personal injury.

- Always *Disconnect* the negative (black) battery cable before disconnecting the positive (red) cable.
- Always *Reconnect* the positive (red) battery cable before reconnecting the negative (black) cable.

- Disengage the PTO, move the motion control levers to the neutral locked position and set the parking brake.

2. Stop the engine, remove the key, and wait for all moving parts to stop before leaving the operating position.
3. Unlatch the seat and tilt the seat up.
4. First disconnect the negative battery cable and ground wire from the negative (-) battery terminal (Fig. 66).
5. Slide the red terminal boot off the positive (red) battery terminal. Then remove the positive (red) battery cable (Fig. 66).
6. Remove both wing nuts (1/4 inch) securing the battery clamp (Fig. 66).
7. Remove the battery.

Adding Water to the Battery

Note: Never fill the battery with distilled water while the battery installed in the machine. Electrolyte could be spilled on other parts and cause corrosion.

The best time to add distilled water to the battery is just before you operate the machine. This lets the water mix thoroughly with the electrolyte solution.

1. Remove the battery from the machine.
2. Clean the top of the battery with a paper towel.
3. Remove the vent caps from the battery (Fig. 65).
4. Slowly pour distilled water into each battery cell until the level is up to the **upper** line (Fig. 65) on the battery case.

Important Do not overfill the battery because electrolyte (sulfuric acid) can cause severe corrosion and damage to the chassis.

5. Wait five to ten minutes after filling the battery cells. Add distilled water, if necessary, until the electrolyte level is up to the **upper** line (Fig. 65) on the battery case.
6. Reinstall battery vent caps.

Charging the Battery



Warning



Charging the battery produces gasses that can explode.

Never smoke near the battery and keep sparks and flames away from battery.

Important Always keep the battery fully charged (1.265 specific gravity). This is especially important to prevent battery damage when the temperature is below 32°F (0°C).

1. Remove the battery from the chassis; refer to Removing the Battery, page 45.
2. Check the electrolyte level; refer to Checking Electrolyte Level, page 44.
3. Make sure the filler caps are installed in battery. Charge battery for 10 to 15 minutes at 25 to 30 amps or 30 minutes at 4–6 amps.
4. When the battery is fully charged, unplug the charger from the electrical outlet, then disconnect the charger leads from the battery posts (Fig. 67).

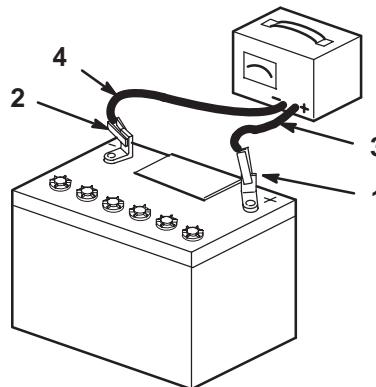

m-4970

Figure 67

- | | |
|--------------------------|---------------------------|
| 1. Positive Battery Post | 3. Red (+) Charger Lead |
| 2. Negative Battery Post | 4. Black (-) Charger Lead |

5. Install the battery in the machine and connect the battery cables; refer to Installing the Battery on page 45.

Note: Do not run the machine with the battery disconnected, electrical damage may occur.

Leveling the Mower at Three Positions

Important There are only three measuring positions needed to level the mower.

Setting Up the Machine

1. Position mower on a flat surface.
2. Disengage the PTO, move the motion control levers to the neutral locked position and set the parking brake.
3. Stop the engine, remove the key, and wait for all moving parts to stop before leaving the operating position.

4. Check tire pressure of all four tires. If needed, adjust to 13 psi (90 kPa)
5. Lower the mower to the 3 inch (76 mm) height-of-cut position.
6. Inspect the four chains. The chains need to have tension.
 - If one rear chain is loose, lower (loosen) the front support arm on the same side. Refer to Adjusting the Front-to-Rear Mower Pitch on page 48.
 - If one front chain is loose, raise (tighten) the front support arm for that chain. Refer to Adjusting the Front-to-Rear Mower Pitch on page 48.

Leveling the Mower Side-to-Side

1. Position the **right** blade front-to-rear (Fig. 68).
2. Measure the right blade at the **B** location (Fig. 68), from a level surface to the cutting edge of the blade tip (Fig. 69).
3. Record this measurement. This measurement needs to be 3-1/8 to 3-1/4 inches.
4. Position the **left** blade front-to-rear (Fig. 68).
5. Measure the left blade at the **C** location (Fig. 68), from a level surface to the cutting edge of the blade tip (Fig. 69).
6. Record this measurement. This measurement needs to be 3-1/8 to 3-1/4 inches.

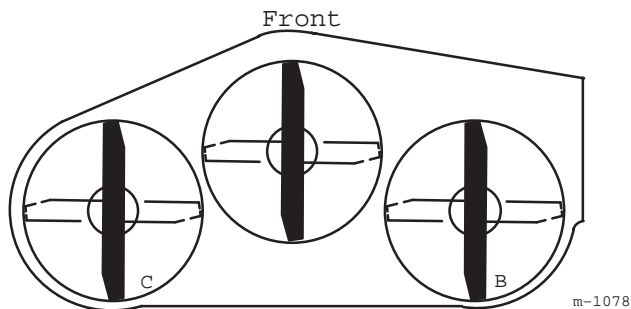
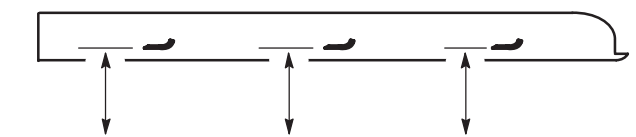

Figure 68



MEASURE FROM
CUTTING EDGE TO
A LEVEL SURFACE

Figure 69

7. If the measurements at positions **B** or **C** are not correct, loosen the bolt attaching the rear chain to the rear support arm (Fig. 70).
8. Loosen the jam nut under the rear support arm and adjust the adjustment bolt to get a measurement of 3-1/8 to 3-1/4 inches.

Note: It is recommended that both sides of the mower are adjusted the same distance.

9. Tighten the jam nut under the rear support arm and tighten the bolt securing the chain to the rear support arm.
10. Adjust the opposite side if needed.

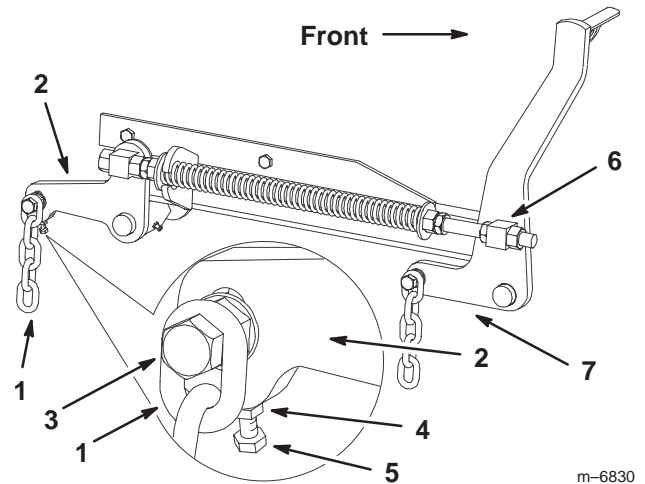

Figure 70

- | | |
|---------------------|----------------------|
| 1. Rear chain | 5. Adjustment bolt |
| 2. Rear support arm | 6. Front swivel |
| 3. Bolt | 7. Front support arm |
| 4. Jam Nut | |

m-6830

Adjusting the Front-to-Rear Mower Pitch

1. Position the **right** blade front-to-rear (Fig. 71).
2. Measure the right blade at the **A** location (Fig. 71), from a level surface to the cutting edge of the blade tip (Fig. 72).
3. Record this measurement.
4. Measure the right blade at the **B** location (Fig. 71), from a level surface to the cutting edge of the blade tip (Fig. 72).
5. Record this measurement.
6. The mower blade should be a **1/4 to 3/8 inch (6 to 10 mm) lower at position A than at position B** (Fig. 71). If it is not correct, proceed to the following steps.

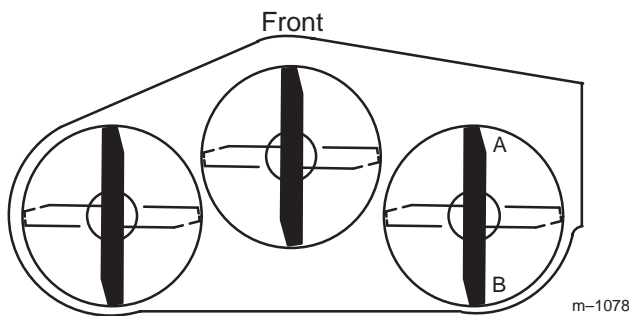
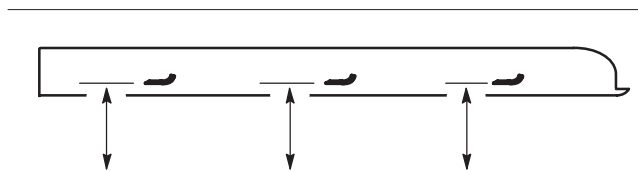

Figure 71



MEASURE FROM
CUTTING EDGE TO
A LEVEL SURFACE

Figure 72

Note: Both of the front swivels need to be adjusted the same amount to maintain equal chain tension.

7. Loosen the front swivel jam nuts, at the front of the right and left swivels, approximately a 1/2 inch (13 mm) (Fig. 73).
8. Adjust the lift nuts on both the left and the right side of the machine to achieve **1/4 to 3/8 inch (6 to 10 mm) lower in front at A than in the rear at B** (Fig. 73).
9. Tighten both swivel jam nuts against the front swivel to lock the height.

10. Check to make sure there is equal tension on the chains and adjust again if needed.

Adjusting the Compression Spring

1. Raise the mower lift lever to the transport position (Fig. 16).
2. Check the distance between the two large washers, it needs to be 10-1/2 inches (26.7 cm) (Fig. 73).
3. Adjust this distance, by loosening the spring jam nut and turning the nut in front of each spring (Fig. 73). Turning the nut clockwise will shorten the spring; counter-clockwise will lengthen the spring.
4. Lock the nut into position by tightening the spring jam nut (Fig. 73).

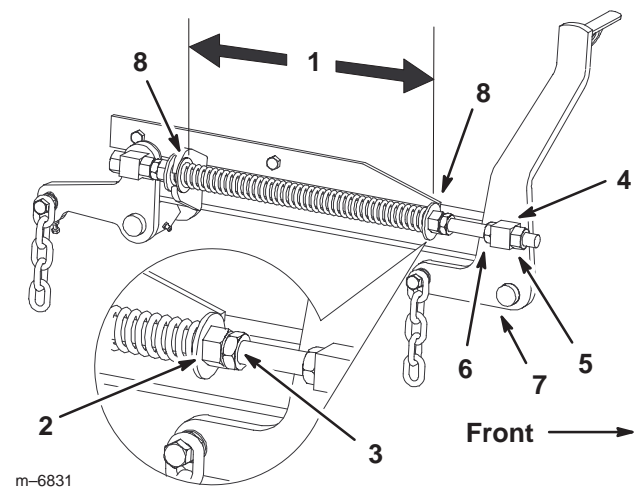

Figure 73

- | | |
|--|----------------------|
| 1. 10-1/2 inch (26.7 cm) between the large washers | 4. Front swivel |
| 2. Front nut | 5. Swivel jam nut |
| 3. Spring jam nut | 6. Lift nut |
| | 7. Front support arm |
| | 8. Large washer |

Cleaning Under the Mower

Remove the grass buildup under the mower daily.

1. Disengage the PTO, move the motion control levers to the neutral locked position and set the parking brake.
2. Stop the engine, remove the key, and wait for all moving parts to stop before leaving the operating position.
3. Raise the mower to the transport position.
4. Raise the front of the machine by using the Z Stand; refer to Using the Z Stand, page 26.



Warning



Unit could fall onto someone and cause serious injury or death.

- Use extreme caution when operating unit on Z Stand.
- Use only for cleaning mower and removing blades.
- Do not keep unit on Z Stand for extended periods of time.
- Always shut engine off and set parking brake before performing any maintenance to mower.

Inspecting the Belts

Inspect all belts every 100 hours.

1. Check belts for cracks, frayed edges, burn marks or any other damage. Replace damaged belts.

Replacing the Mower Belt

Squealing when the belt is rotating, blades slipping when cutting grass, frayed belt edges, burn marks and cracks are signs of a worn mower belt. Replace the mower belt if any of these conditions are evident.

1. Disengage the PTO, move the motion control levers to the neutral locked position and set the parking brake.
2. Stop the engine, remove the key, and wait for all moving parts to stop before leaving the operating position.
3. Remove the belt covers (Fig. 75).
4. Loosen the nut securing the idler plate and move the idler plate to relieve the belt tension on the idler pulley, then remove the worn mower belt (Fig. 77).
5. Install the new mower belt around the mower spindle pulleys, mower idler pulley, into the belt guides, into rear idler arm assembly, and the clutch (Fig. 74).

Important Check the amount of twist in the belt between the pulleys. Make sure it is only what is specified in Figure 74.

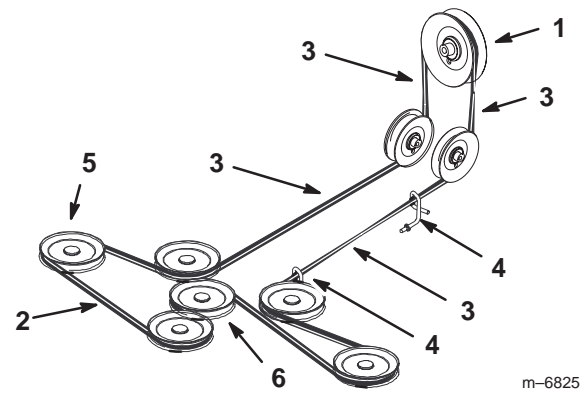

m-6825

Figure 74

- | | |
|------------------------|-------------------------|
| 1. Clutch | 4. Belt guide |
| 2. Mower belt | 5. Mower spindle pulley |
| 3. 1/4 turn belt twist | 6. Mower idler pulley |

6. Adjust the belt tension, refer to Adjusting the Mower Belt Tension; page 49.
7. Install the belt covers and close the latches (Fig. 75).

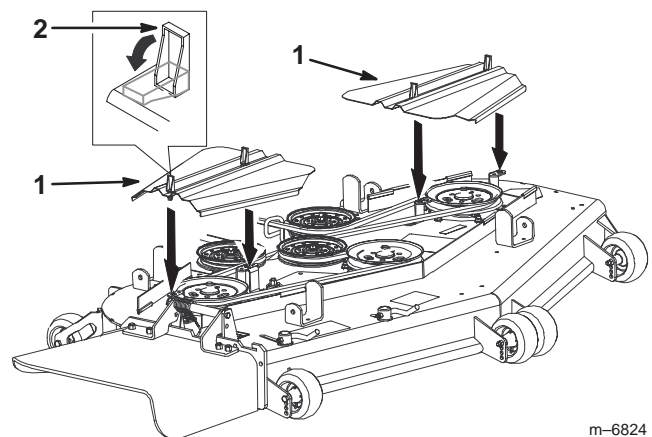

m-6824

Figure 75

- | | |
|---------------|----------|
| 1. Belt cover | 2. Latch |
|---------------|----------|

Adjusting the Mower Belt Tension

1. Disengage the PTO, move the motion control levers to the neutral locked position and set the parking brake.
2. Stop the engine, remove the key, and wait for all moving parts to stop before leaving the operating position.
3. Raise the mower to the transport position.

Important Check the amount of twist in the belt between the pulleys. Make sure it is only what is specified in Figure 74.

Important Check and make sure the belt is installed into both the front and rear belt guides (Fig 76).

4. Check the belt tension. The spring loaded idler center bolt needs to be near the top alignment hole in left support plate (Fig 76).

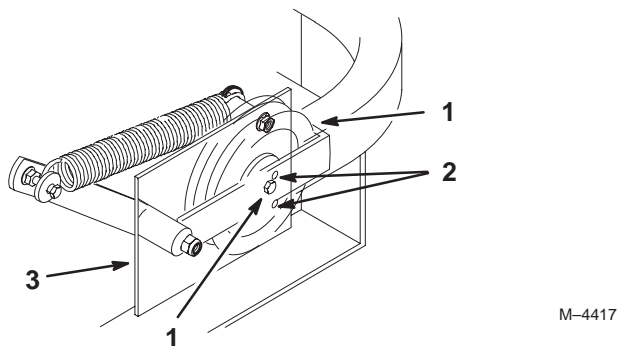

Figure 76

- | | |
|-------------------|------------------------|
| 1. Center bolt | 3. Left support plate |
| 2. Alignment hole | 4. Spring loaded idler |

5. If adjustment is required, loosen the mower idler plate and adjust it (Fig. 77).

6. Insert a ratchet or breaker bar into the square hole in the mower idler plate to adjust the tension (Fig. 77).

7. To increase belt tension, rotate the mower idler plate until resistance is felt and rotation stops. Do not go past when it stops (Fig. 77).

8. Tighten the idler plate bolts (Fig. 77).

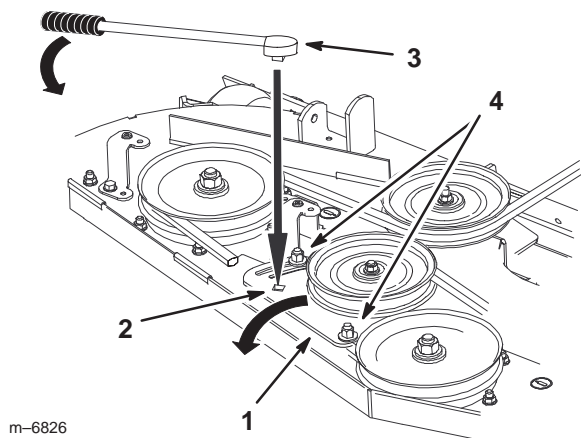

Figure 77

- | | |
|----------------------|---------------------------|
| 1. Mower idler plate | 3. Ratchet or breaker bar |
| 2. Square hole | 4. Idler plate bolt |

9. Check the distance from the rubber stop and the arm of the spring loaded idler pulley when the idler plate is tightened. It needs to be 0 to 1/4 inch (0 to 6 mm) from the rubber stop (Fig. 78).

10. Adjust the belt tension and the idler plate, if necessary, and tighten all hardware securely (Fig. 77).

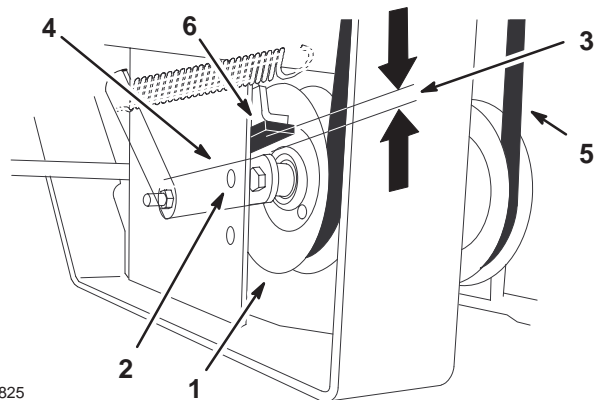

Figure 78

- | | |
|----------------------------------|---------------------|
| 1. Spring loaded idler pulley | 4. Idler pulley arm |
| 2. Top alignment hole | 5. Belt |
| 3. 0 to 1/4 inch gap (0 to 6 mm) | 6. Rubber bumper |

11. If the mower idler plate contacts the end of the adjustment slot and more belt tension is required, a small change to the right side fixed idler can create more belt tension adjustment (Fig. 79).

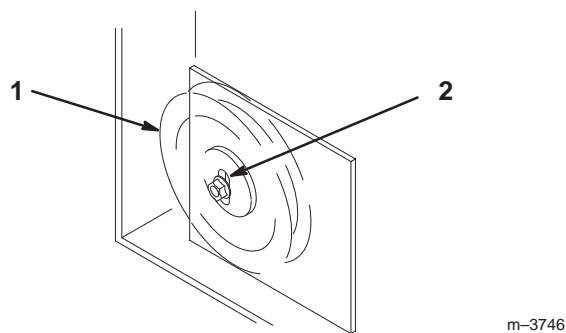

Figure 79

- | | |
|----------------|--------------------|
| 1. Fixed Idler | 2. Adjustment slot |
|----------------|--------------------|

Replacing the Grass Deflector



Warning



An uncovered discharge opening could allow the lawn mower to throw objects in the operator's or bystander's direction and result in serious injury. Also, contact with the blade could occur.

- Never operate the lawn mower unless you install a cover plate, a mulch plate, or a grass chute and catcher.
- Make sure the grass deflector is in the down position.

1. Remove the locknut, bolt, spring and spacer holding the deflector to the pivot brackets (Fig. 80). Remove damaged or worn grass deflector.
2. Place spacer and spring onto grass deflector. Place the L end of spring behind deck edge.

Note: Make sure the L end of spring is installed behind deck edge before installing the bolt as shown in figure 80.

3. Install bolt and nut. Place J hook end of spring around grass deflector (Fig. 80).

Important The grass deflector must be able to lower down into position. Lift the deflector up to test that it lowers into the full down position.

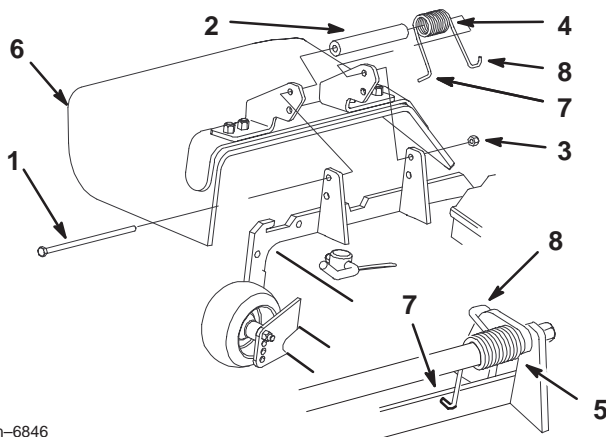

m-6846

Figure 80

- | | |
|---------------------|---|
| 1. Bolt | 6. Grass Deflector |
| 2. Spacer | 7. L end of spring, place behind deck edge before installing bolt |
| 3. Locknut | 8. J hook end of spring |
| 4. Spring | |
| 5. Spring installed | |

Mercury Tilt Switch

The tilt switch on this unit contains mercury, a hazardous material. Mercury that is outside a sealed container vaporizes at room temperature. The vapors are harmful. Mercury can be absorbed through the skin. Do not attempt to open or repair this switch.

A very small amount of mercury is contained in a hermetically sealed body. The steel switch is then potted in a hard epoxy in a plastic case. It is unlikely that the mercury will ever escape from the enclosure. These high performance and reliable inexpensive switches are recyclable.

Mercury is an important and beneficial compound but requires special care in handling and disposal. When used and managed properly, mercury is not a threat to people or the environment. This information is presented to users so that they are aware that these switches contain mercury and will apply sound disposal practices when these devices reach their normal end of life or are damaged.

Disposing the Mercury Tilt Switch

Several states have passed laws concerning the disposal of devices containing mercury. In all the remaining states it is advisable to follow similar procedures. The laws state that these sealed devices contain mercury and should not be placed in the garbage until the mercury is removed and reused, recycled or otherwise managed to insure that it does not become part of solid waste or waters. Management and disposal practices must be within relevant federal, state or local laws.

Return the switch to your Toro dealer if it is faulty and is being replaced or if the unit containing the switch is no longer operating and is being scrapped. If the switch is damaged or broken open use extreme caution in handling. Call your local waste management authority or Toro Customer Service for instructions.



Caution



The mercury contained in the tilt switch is poisonous and exposure to mercury can cause severe illness.

- Never attempt to open or repair the tilt switch.
- Avoid contact with the mercury.

Cleaning and Storage

1. Disengage the power take off (PTO), set the parking brake and turn the ignition key to off. Remove spark plug wire. Remove the key.
2. Remove grass clippings, dirt, and grime from the external parts of the entire machine, especially the engine and hydraulic system. Clean dirt and chaff from the outside of the engine's cylinder head fins and blower housing.

Important You can wash the machine with mild detergent and water. Do not pressure wash the machine. Avoid excessive use of water, especially near the control panel, engine, hydraulic pumps and motors.

3. Service the air cleaner; refer to Servicing the Air Cleaner, page 32.
4. Grease and oil the machine; refer to Greasing and Lubrication, page 36.
5. Change the crankcase oil; refer to Servicing the Engine Oil, page 33.
6. Change the hydraulic filter; refer to Servicing the Hydraulic System, page 39.
7. Check the tire pressure; refer to Checking the Tire Pressure, page 38.
8. Charge the battery; refer to Servicing the Battery page 44.
9. Scrape any heavy buildup of grass and dirt from the underside of the mower, then wash the mower with a garden hose.

Note: Run the machine with the PTO engaged and the engine at high idle for 2 to 5 minutes after washing.

10. Check the condition of the blades. Refer to Servicing the Cutting Blades on page 30.
11. Prepare the machine for storage when non-use occurs over 30 days. Prepare machine for storage as follows.
 - A. Add a petroleum based stabilizer/conditioner to fuel in the tank. Follow mixing instructions from stabilizer manufacture. **Do not use an alcohol based stabilizer (ethanol or methanol).**

Note: A fuel stabilizer/conditioner is most effective when mixed with fresh gasoline and used at all times.

- B. Run engine to distribute conditioned fuel through the fuel system (5 minutes).
- C. Stop engine, allow to cool and drain the fuel tank; refer to Servicing the Fuel Tank, page 36.
- D. Restart engine and run it until it stops.
- E. Choke the engine. Start and run engine until it will not start.
- F. Dispose of fuel properly. Recycle as per local codes.

Important Do not store stabilizer/conditioned gasoline over 90 days.

12. Remove the spark plug(s) and check its condition; refer to Servicing the Spark Plug, page 34. With the spark plug(s) removed from the engine, pour two tablespoons of engine oil into the spark plug hole. Now use the starter to crank the engine and distribute the oil inside the cylinder. Install the spark plug(s). Do not install the wire on the spark plug(s).
13. Check and tighten all bolts, nuts, and screws. Repair or replace any part that is damaged or defective.
14. Paint all scratched or bare metal surfaces. Paint is available from your Authorized Service Dealer.
15. Store the machine in a clean, dry garage or storage area. Remove the key from the ignition switch and keep it out of reach of children or other unauthorized users. Cover the machine to protect it and keep it clean.

Troubleshooting

Problem	Possible Causes	Corrective Action
Starter does not crank	<ol style="list-style-type: none"> 1. Blade control (PTO) is engaged. 2. Parking brake is not on. 3. Operator is not seated. 4. Battery is dead. 5. Electrical connections are corroded or loose. 6. Fuse is blown. 7. Relay or switch is defective. 	<ol style="list-style-type: none"> 1. Move blade control (PTO) to disengaged. 2. Set parking brake. 3. Sit on the seat. 4. Charge the battery. 5. Check electrical connections for good contact. 6. Replace fuse. 7. Contact Authorized Service Dealer.
Engine will not start, starts hard, or fails to keep running.	<ol style="list-style-type: none"> 1. Fuel tank is empty. 2. Choke is not on. 3. Air cleaner is dirty. 4. Spark plug wires is loose or disconnected. 5. Spark plugs are pitted, fouled, or gap is incorrect. 6. Dirt in fuel filter. 7. Dirt, water, or stale fuel is in fuel system. 	<ol style="list-style-type: none"> 1. Fill fuel tank with gasoline. 2. Move choke lever to on. 3. Clean or replace air cleaner element. 4. Install wires on spark plug. 5. Install new, correctly gapped spark plugs. 6. Replace fuel filter. 7. Contact Authorized Service Dealer.
Engine loses power.	<ol style="list-style-type: none"> 1. Engine load is excessive. 2. Air cleaner is dirty. 3. Oil level in crankcase is low. 4. Cooling fins and air passages under engine blower housing are plugged. 5. Spark plugs are pitted, fouled, or gap is incorrect. 6. Vent in fuel cap is closed. 7. Dirt in fuel filter. 8. Dirt, water, or stale fuel is in fuel system. 	<ol style="list-style-type: none"> 1. Reduce ground speed. 2. Clean air cleaner element. 3. Add oil to crankcase. 4. Remove obstruction from cooling fins and air passages. 5. Install new, correctly gapped spark plugs. 6. Open vent in fuel cap. 7. Replace fuel filter. 8. Contact Authorized Service Dealer.
Engine overheats.	<ol style="list-style-type: none"> 1. Engine load is excessive. 2. Oil level in crankcase is low. 3. Cooling fins and air passages under engine blower housing are plugged. 	<ol style="list-style-type: none"> 1. Reduce ground speed. 2. Add oil to crankcase. 3. Remove obstruction from cooling fins and air passages.

Problem	Possible Causes	Corrective Action
Machine does not drive.	<ol style="list-style-type: none"> 1. Traction belt is worn, loose or broken. 2. Traction belt is off pulley. 3. Hydro fluid level low. 	<ol style="list-style-type: none"> 1. Contact Authorized Service Dealer. 2. Contact Authorized Service Dealer. 3. Add hydro fluid to reservoir.
Abnormal vibration.	<ol style="list-style-type: none"> 1. Cutting blade(s) is/are bent or unbalanced. 2. Blade mounting bolt is loose. 3. Engine mounting bolts are loose. 4. Loose engine pulley, idler pulley, or blade pulley. 5. Engine pulley is damaged. 6. Blade spindle bent. 	<ol style="list-style-type: none"> 1. Install new cutting blade(s). 2. Tighten blade mounting bolt. 3. Tighten engine mounting bolts. 4. Tighten the appropriate pulley. 5. Contact Authorized Service Dealer. 6. Contact Authorized Service Dealer.
Uneven cutting height.	<ol style="list-style-type: none"> 1. Blade(s) not sharp. 2. Cutting blade(s) is/are bent. 3. Mower is not level. 4. Anti-scalp roller is not set correctly. 5. Underside of mower is dirty. 6. Tire pressure is incorrect. 7. Blade spindle bent. 	<ol style="list-style-type: none"> 1. Sharpen blade(s). 2. Install new cutting blade(s). 3. Level mower from side-to-side and front-to-rear. 4. Adjust gage wheel height. 5. Clean the underside of the mower. 6. Adjust tire pressure. 7. Contact Authorized Service Dealer.
Blades do not rotate.	<ol style="list-style-type: none"> 1. Mower belt is off the pulley. 2. Mower belt is worn, loose or broken. 3. Electric clutch does not engage. 4. Electric clutch is worn. 	<ol style="list-style-type: none"> 1. Install the mower belt and check the adjusting plate, idler arm and spring, and belt guides for correct position 2. Install a new mower belt. 3. Contact Authorized Service Dealer. 4. Contact Authorized Service Dealer.



LCE

The Toro Total Coverage Guarantee

A Limited Warranty

Conditions and Products Covered

The Toro Company and its affiliate, Toro Warranty Company, pursuant to an agreement between them, jointly promise to repair the listed Toro Products if defective in materials or workmanship. The following time periods apply from the date of purchase:

<u>Products</u>	<u>Warranty Period</u>
• All Products	1 year
• All Spindles	2 years parts and labor; third year, parts only
• Engines/Hydraulic Systems* on the following: Outfront and Mid-Mount Z's ProLine Mid-Size Mowers Groundsmaster® Riding Mowers Backpack Blowers	2 years
• Deck Shells (36"–72") on the following: ProLine Mid-Size Mowers Mid-Mount Z's	2 years
• Electric Clutch on 200 Series Mid-Mount Z's	2 years

This warranty includes the cost of parts and labor, but you must pay transportation costs.

This warranty applies to:

- Outfront and Mid-Mount Z's
- ProLine Mid-Size Mowers
- Groundsmaster Riding Mowers
- Turf Maintenance Equipment
- Debris Management Equipment

* Some engines used on Toro LCE Products are warranted by the engine manufacturer.

Instructions for Obtaining Warranty Service

If you think that your Toro Product contains a defect in materials or workmanship, follow this procedure:

1. Contact any Toro Authorized or Master Service Dealer to arrange service at their dealership. To locate a dealer convenient to you, access our website at www.Toro.com. U.S. Customers may also call 800-348-2424.
2. Bring the product and your proof of purchase (sales receipt) to the Service Dealer.

If for any reason you are dissatisfied with the Service Dealer's analysis or with the assistance provided, contact us at:

LCB Customer Service Department
Toro Warranty Company
8111 Lyndale Avenue South
Bloomington, MN 55420-1196
888-577-7466 (U.S. customers)
877-484-9255 (Canada customers)

Countries Other than the United States or Canada

Customers who have purchased Toro products exported from the United States or Canada should contact their Toro Distributor (Dealer) to obtain guarantee policies for your country, province, or state. If for any reason you are dissatisfied with your Distributor's service or have difficulty obtaining guarantee information, contact the Toro importer. If all other remedies fail, you may contact us at Toro Warranty Company.

Owner Responsibilities

You must maintain your Toro Product by following the maintenance procedures described in the operator's manual. Such routine maintenance, whether performed by a dealer or by you, is at your expense.

Items and Conditions Not Covered

There is no other express warranty except for special emission system coverage on some products. This express warranty does not cover the following:

- Cost of regular maintenance service or parts, such as filters, fuel, lubricants, tune-up parts, blade sharpening, brake and clutch adjustments.
- Any product or part which has been altered or misused or required replacement or repair due to normal wear, accidents, or lack of proper maintenance.
- Repairs necessary due to improper fuel, contaminants in the fuel system, or failure to properly prepare the fuel system prior to any period of non-use over three months.
- Pickup and delivery charges.

All repairs covered by this warranty must be performed by an Authorized Toro Service Dealer using Toro approved replacement parts.

General Conditions

Repair by an Authorized Toro Service Dealer is your sole remedy under this warranty.

Neither The Toro Company nor Toro Warranty Company is liable for indirect, incidental or consequential damages in connection with the use of the Toro Products covered by this warranty, including any cost or expense of providing substitute equipment or service during reasonable periods of malfunction or non-use pending completion of repairs under this warranty.

Some states do not allow exclusions of incidental or consequential damages, or limitations on how long an implied warranty lasts, so the above exclusions and limitations may not apply to you.

All implied warranties of merchantability (that the product is fit for ordinary use) and fitness for use (that the product is fit for a particular purpose) are limited to the duration of the express warranty.

This warranty gives you specific legal rights, and you may also have other rights which vary from state to state.