



**Count on it.**

**Parts Catalog**

**36in Sprayer  
SprayMaster**

Model No. 34246—Serial No. 40000000 and Up



# Ordering Replacement Parts

To order replacement parts, please supply the part number, the quantity, and the description of each part desired.

## Understanding Reference Numbers

Each identified part in an illustration has a reference number. The reference number for a part also appears in the parts list, along with other information about the part.

This catalog uses two special reference number formats, one to indicate parts in a service assembly and another to indicate the quantity of a given part in an illustration.

## Service Assembly Reference Numbers

Parts in service assemblies have reference numbers in the form a:b. The a represents the reference number of the entire service assembly and the b represents a sequential number unique to each part within the service assembly.

For example, a wheel assembly might be identified by reference number 6, the tire by 6:1, the valve by 6:2, and the wheel by 6:3. When you order the assembly identified by reference number 6, you receive all parts identified by reference numbers 6:1, 6:2, and 6:3. However, you may also order any part individually. Reference numbers of this type appear in illustration and in parts lists.

## Reference Numbers Indicating Quantity

In an illustration, if a reference number indicates more than one part, the reference number has the form nX y. The n represents the quantity of the part, the X is the multiplication symbol, and the y represents the reference number.

For example, in an illustration, the reference number 2X 37 means that two of the parts identified by reference number 37 are indicated.

# Contents

Frame Assembly	4
Engine Assembly	6
Hydraulic Transmission Assembly	8
LH Hydraulic Transmission Assembly No. 142-5596	10
RH Hydraulic Transmission Assembly No. 142-5595	12
Idler Arm Assembly No. 142-9334	14
Brake Assembly	16
Electrical Assembly	18
Foot Switch Assembly	20
Controls Assembly	22
Tire Assembly	24
Caster Wheels Assembly	26
Fuel Tank Assembly	28
Fuel Tank Assembly No. 142-7602	30
Spreader Assembly	32
Hopper Motor Assembly	34
Hopper Console Assembly	36
Sprayer Tanks Assembly	38
Sprayer Manifold Assembly No. 142-7050	40
Boom Assembly	42
Pump Assembly	44
Spray Gun Assembly	46
Hopper Cover, Knee Pad and Battery Assembly	48
Attachments and Accessories	50

# Frame Assembly

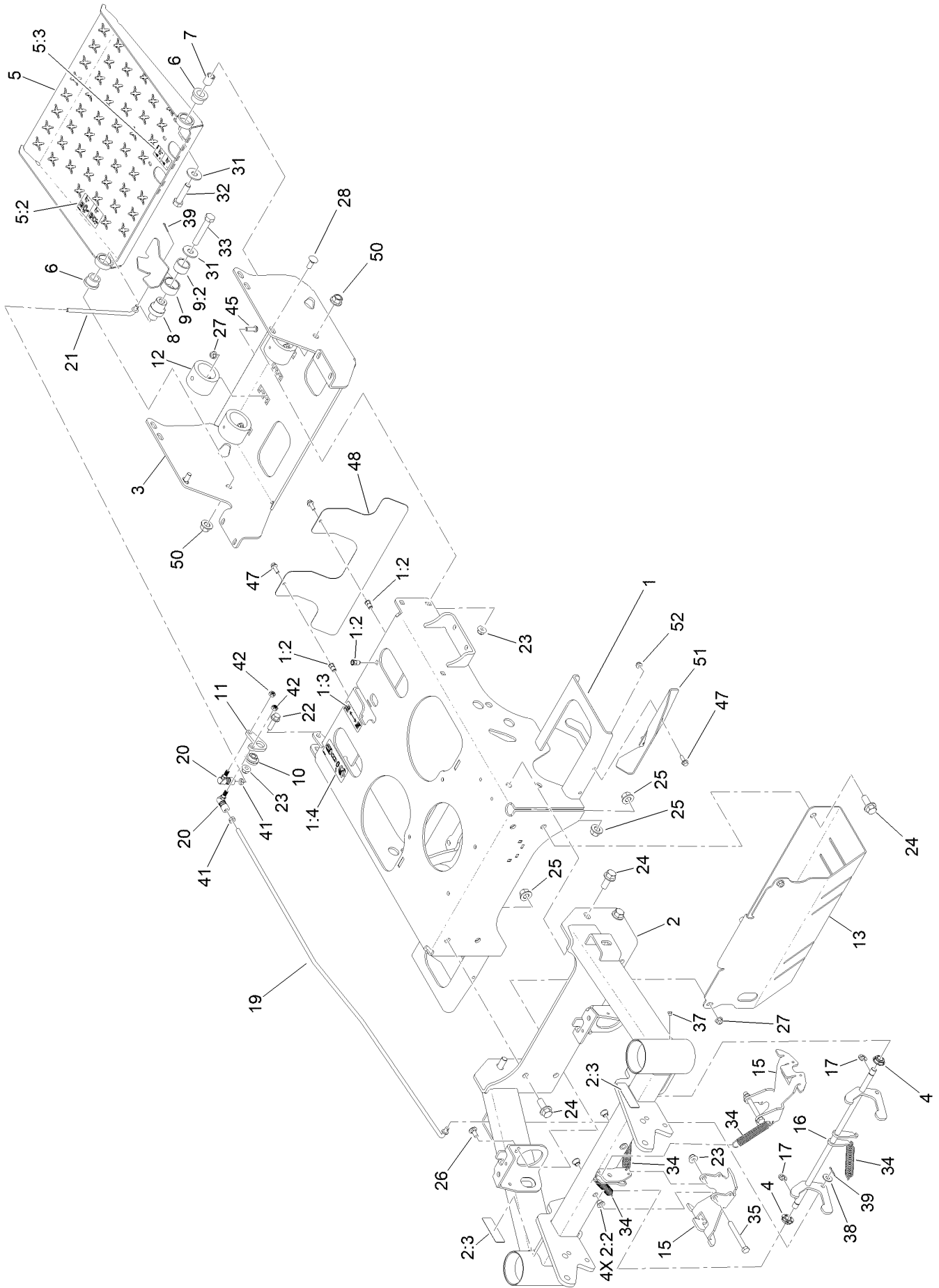

## Frame Assembly (continued)

<i>Ref.</i>	<i>Part Number</i>	<i>Qty.</i>	<i>Description</i>	<i>Ref.</i>	<i>Part Number</i>	<i>Qty.</i>	<i>Description</i>
1	142-7607	1	Frame-Rear, Jr36	21	142-6885	1	Linkage-Pedal, Caster
1:2	138-2758	3	Nut-Clinch,Hex	22	135-6211	1	Screw-HHF
1:3	115-9625	1	Decal-Brake, Parking	23	135-6110	5	Nut-Hex Flange
1:4	142-8173	1	Decal-Strainer	24	135-6207	8	Screw-HHF
2	142-7894	1	Frame-Front, Jr36	25	135-6111	8	Nut-Hex Flange
2:2	137-2374	4	Bushing-Flange	26	126-0695	2	Screw-CARR
2:3	120-0625	2	Decal-Warning	27	135-6109	6	Nut-Hex Flange
3	142-8954	1	Mount-Footplate, Jr36	28	126-0980	2	Screw-CARR
4	126-5820	2	Bearing-Spherical	31	3256-6	2	Washer-Flat
5	142-6884	1	Foot Plate W/Decals	32	325-8	1	Screw-HH
5:2	135-6430	1	Decal-Lock, Caster	33	325-12	1	Screw-HH
5:3	135-6728	1	Decal-Button, Foot (Spray)	34	126-2127	4	Spring-Extension
6	142-6033	2	Bushing-Rubber	35	126-2661	2	Screw-HH
7	142-6034	1	Spacer	37	1-811010	2	Plug
8	142-6878	1	Pivot-Pedal, Caster	38	HDW14535	1	Flat Washer, 5/16 Nom,ST/ST,18-8
9	142-4222	1	Pedal-Lock, Caster	39	HDW14430	2	Cotter Pin 5/64X3/4 18-8
9:2	116-9538	1	Bushing	41	107-0282	2	Nut-Hex
10	126-5989	1	Pivot-Flange	42	142-5498	2	Nut-Lock, NI
11	142-3960	1	Crank-Deflector	45	119-6903	4	Screw-HSBH
12	135-2548	4	Bumper-Isolator	47	135-6221	4	Screw-HHF
13	142-8930	1	Guard-Muffler	48	142-7335	1	Deflector-Heat
15	142-4431	2	Arm-Lock, Caster	50	99-5107	2	Nut-Lock
16	142-5594	1	Crank-Lock, Caster	51	146-1148	1	Shield-Tank Heat
17	142-4698	2	Ring-E	52	135-6108	2	Nut-Hex Flange
19	142-8931	1	Linkage-Lock, Caster				
20	135-5718	2	Ball Joint-Quick Disconnect, SS				

# Engine Assembly

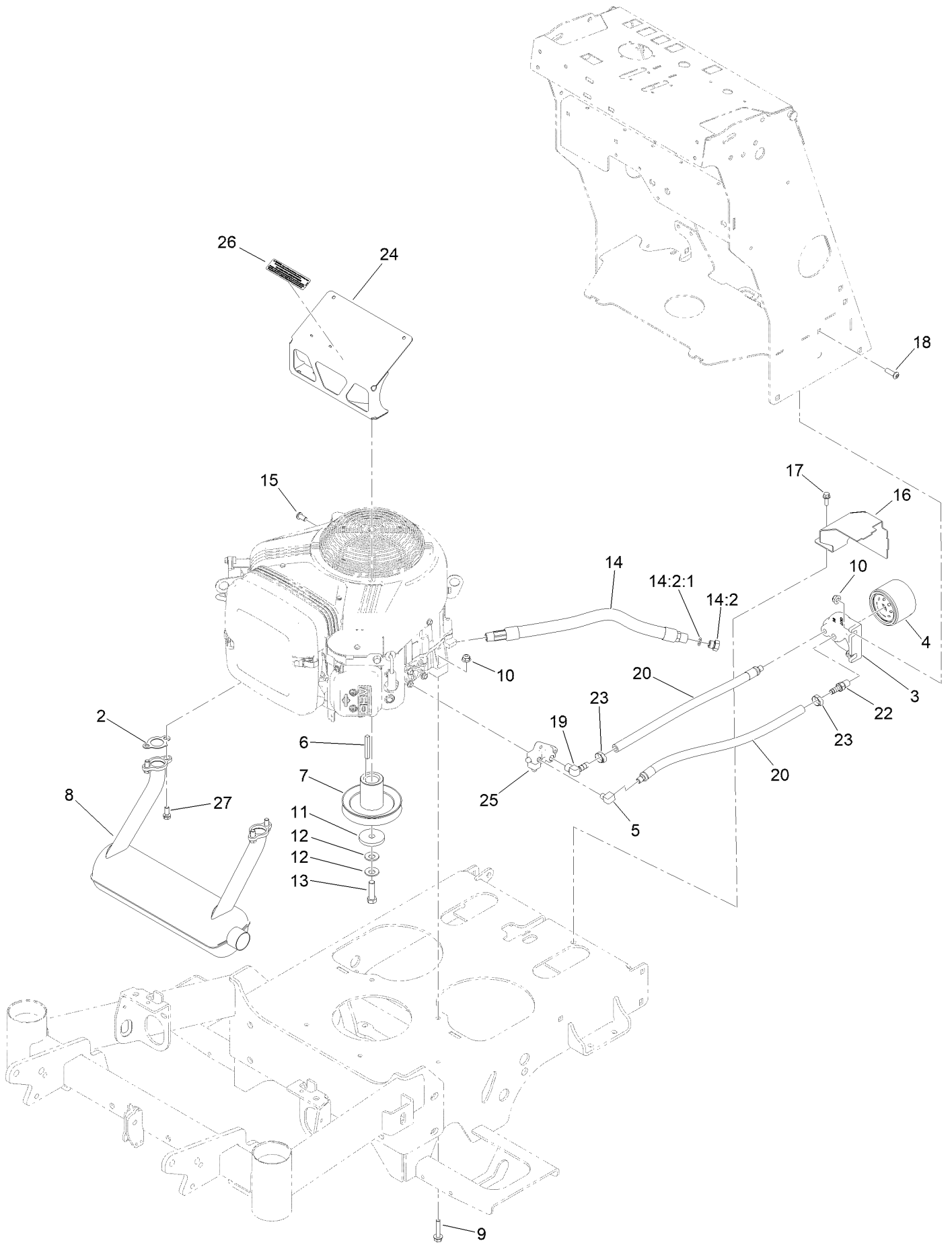

## Engine Assembly (continued)

<i>Ref.</i>	<i>Part Number</i>	<i>Qty.</i>	<i>Description</i>	<i>Ref.</i>	<i>Part Number</i>	<i>Qty.</i>	<i>Description</i>
2	94-3449	2	Gasket-Manifold, Exhaust	14:2:1	237-42	1	O-Ring
3	142-7348	1	Mount-Filter, Remote	15	110-0032	1	Screw-Bhtrorx
4	142-7347	1	Filter-Oil	16	142-7608	1	Cover-Filter
5	142-7351	1	Elbow-Pipe, 90	17	135-6221	1	Screw-HHF
6	103-4177	1	Key	18	119-6903	2	Screw-HSBH
7	142-9341	1	Pulley-Engine	19	354-93	1	Fitting-Elbow, 90
8	135-9245	1	Briggs 16/18 HP Muffler	20	142-7865	2	Hose Am, HYD LP
9	142-0559	4	Screw-HHF	22	108-0342	1	Fitting-Straight
10	135-6109	6	Nut-Hex Flange	23	135-5757	1	Clamp-Oetiker, 167
11	109-6919	1	Washer-Plain	24	142-7880	1	Bracket-Engine
12	1-603610	2	Washer-Spring	25	142-7350	1	Adapter-ASM, Service
13	109-9761	1	Screw-HH	26	133-8062	1	Decal-Spark Arrestor
14	116-5316	1	Oil Drain Hose ASM	27	3274-96	4	Screw-HSBH
14:2	353-508	1	Plug-HH ●				

● Torque to 24-26 ft-lb

# Hydraulic Transmission Assembly

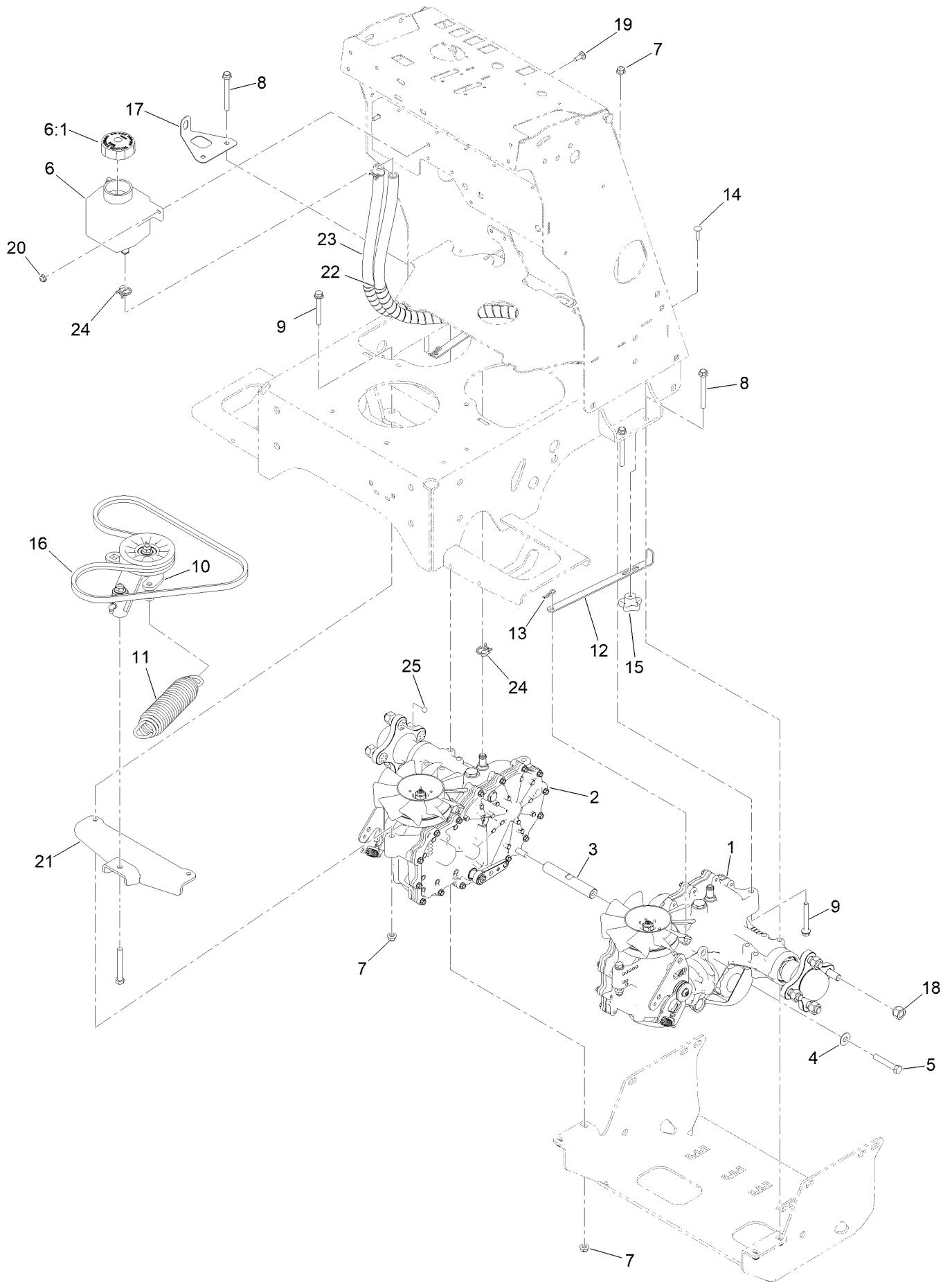



## Hydraulic Transmission Assembly (continued)

<i>Ref.</i>	<i>Part Number</i>	<i>Qty.</i>	<i>Description</i>	<i>Ref.</i>	<i>Part Number</i>	<i>Qty.</i>	<i>Description</i>
1	142-5596	1	Zt3400-Left	13	1-806003	2	Pin-Cotter
2	142-5595	1	Zt3400-Right	14	126-1455	2	Screw-CARR
3	142-4644	1	Shaft-Spacer	15	108-6402	2	Knob-Handle
4	1126	2	Washer-Flat	16	109-1057	1	Belt, Pump Drive
5	HDW05862	2	HHCS,3/8-16X2-1/4ST/ST 18-8	17	142-6352	1	Bracket-Sensor, Speed
6	109-2250	1	Tank-HYD	18	139-2564	8	Nut-Lug
6:1	109-3320	1	Cap-Reservoir, HYD	19	HDW20143	2	Bolt, Carriage, 1/4-20X3/4, ST/ST
7	104-8300	8	Nut-HF, NI	20	135-6108	2	Nut-Hex Flange
8	126-4687	4	Screw-HHF	21	142-6377	1	Mount-Idler
9	138-9270	4	Screw-HHF	22	142-7310	1	Hose-Expansion [wrapped]
10	142-9334	1	ASM-Arm, Idler	23	142-7311	1	Hose-Expansion [wrapped]
11	116-6317	1	Spring-Extension	24	117-1193	4	Clamp-Hose
12	142-6344	2	Arm-Hydro, Bypass	25	135-8903	1	Magnet-Speedometer

# LH Hydraulic Transmission Assembly No. 142-5596

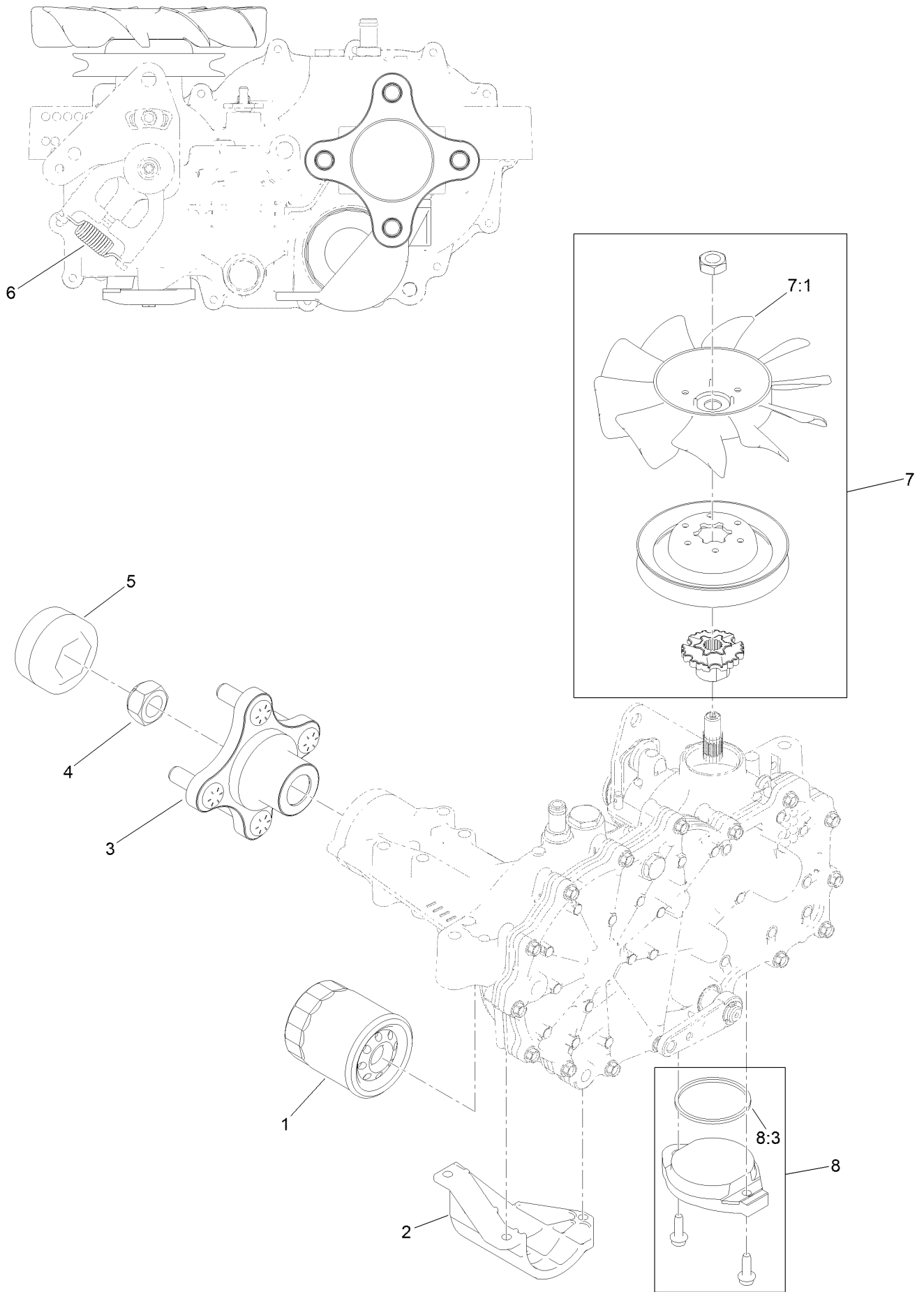

# LH Hydraulic Transmission Assembly No. 142-5596 (continued)

<i>Ref.</i>	<i>Part Number</i>	<i>Qty.</i>	<i>Description</i>	<i>Ref.</i>	<i>Part Number</i>	<i>Qty.</i>	<i>Description</i>
1	109-3321	1	Element-Oil Filter, HYD	7	146-5912	1	Kit-Fan & Pulley
2	139-7498	1	Filter Guard Kit	7:1	126-0226	1	Fan
2	120-7979	1	Guard-Filter, LH	8	146-5913	1	Kit-Charge Pump
3	109-5939	1	Hub Kit	8:3	109-3540	1	O Ring-Seal
4	109-3536	1	Nut-Hub	99	121-3243	1	Seal Kit ●
5	115-5057	1	Cover-Nut, Axle	99	135-2307	1	Kit-Hydro Service, H-G ●
6	125-4684	1	Spring-Extension				

● Not illustrated

# RH Hydraulic Transmission Assembly No. 142-5595

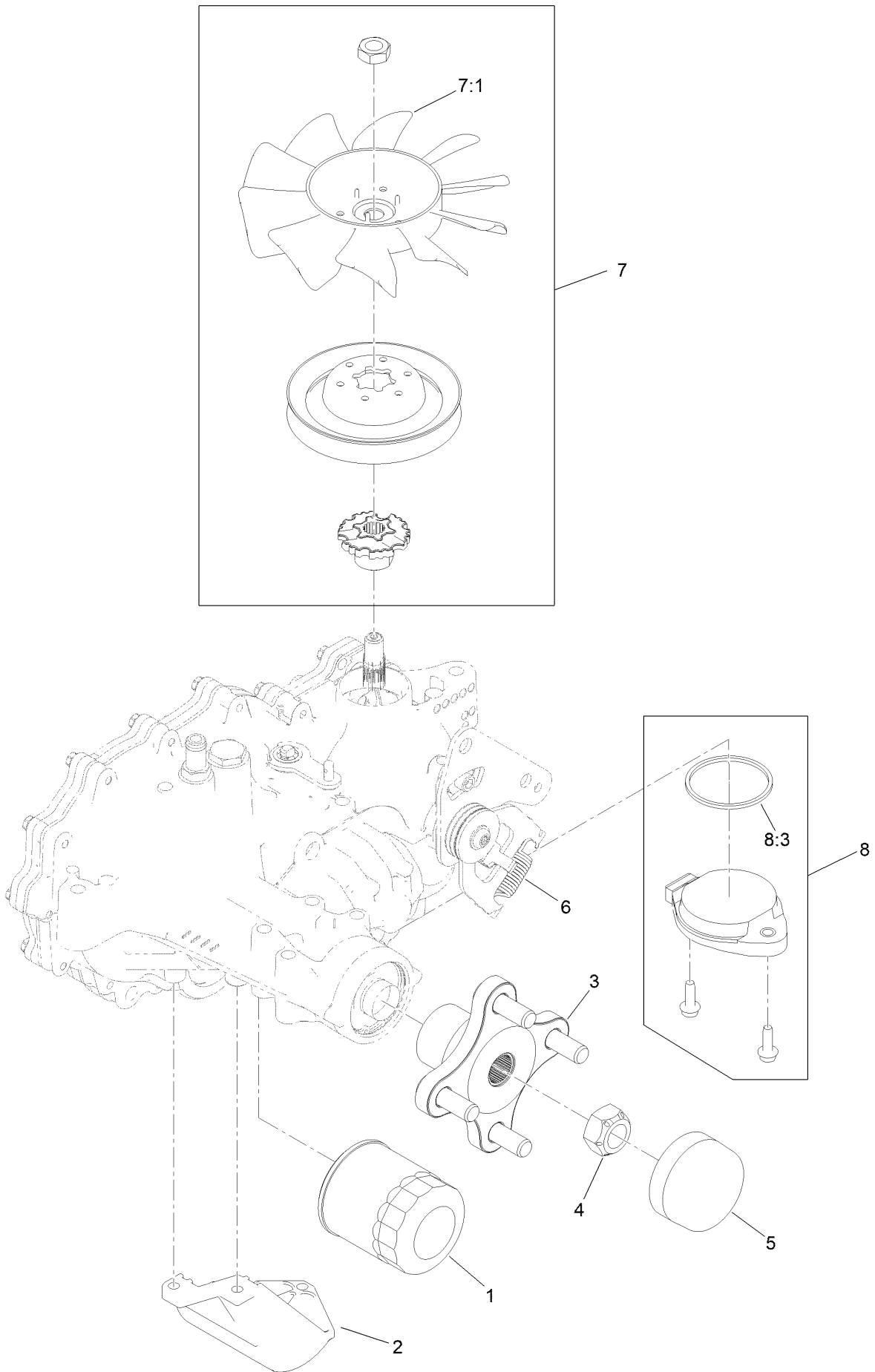

# RH Hydraulic Transmission Assembly No. 142-5595 (continued)

<i>Ref.</i>	<i>Part Number</i>	<i>Qty.</i>	<i>Description</i>	<i>Ref.</i>	<i>Part Number</i>	<i>Qty.</i>	<i>Description</i>
1	109-3321	1	Element-Oil Filter, HYD	7	146-5912	1	Kit-Fan & Pulley
2	120-7981	1	Guard-Filter, RH	7:1	126-0226	1	Fan
2	139-7499	1	Filter Guard Kit	8	146-5913	1	Kit-Charge Pump
3	109-5939	1	Hub Kit	8:3	109-3540	1	O Ring-Seal
4	109-3536	1	Nut-Hub	99	121-3243	1	Seal Kit ●
5	115-5057	1	Cover-Nut, Axle	99	135-2307	1	Kit-Hydro Service, H-G ●
6	125-4684	1	Spring-Extension				

● Not illustrated

# Idler Arm Assembly No. 142-9334

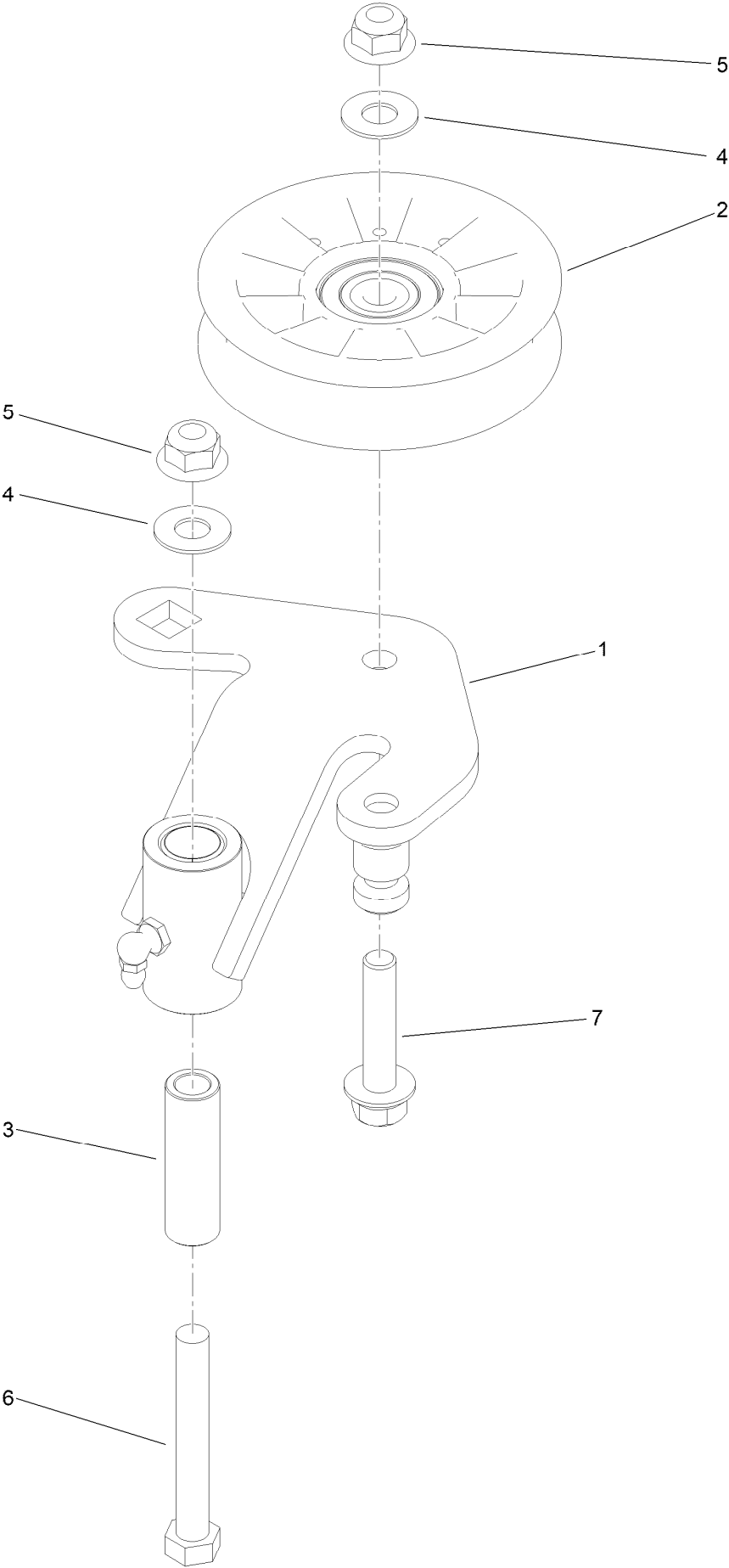

## Idler Arm Assembly No. 142-9334 (continued)

<i>Ref.</i>	<i>Part Number</i>	<i>Qty.</i>	<i>Description</i>	<i>Ref.</i>	<i>Part Number</i>	<i>Qty.</i>	<i>Description</i>
1	142-9335	1	Arm-Idler	5	135-6110	2	Nut-Hex Flange
2	116-2456	1	Pulley-Flat Idler	6	HDW19396	1	HHCS,3/8-16X2-3/4,1TI,ST/ST
3	142-9339	1	Pivot-Idler				18-8
4	HDW05859	2	Washer,Flat,3/8ST/ST 18-8	7	126-2710	1	Screw-HHF

# Brake Assembly

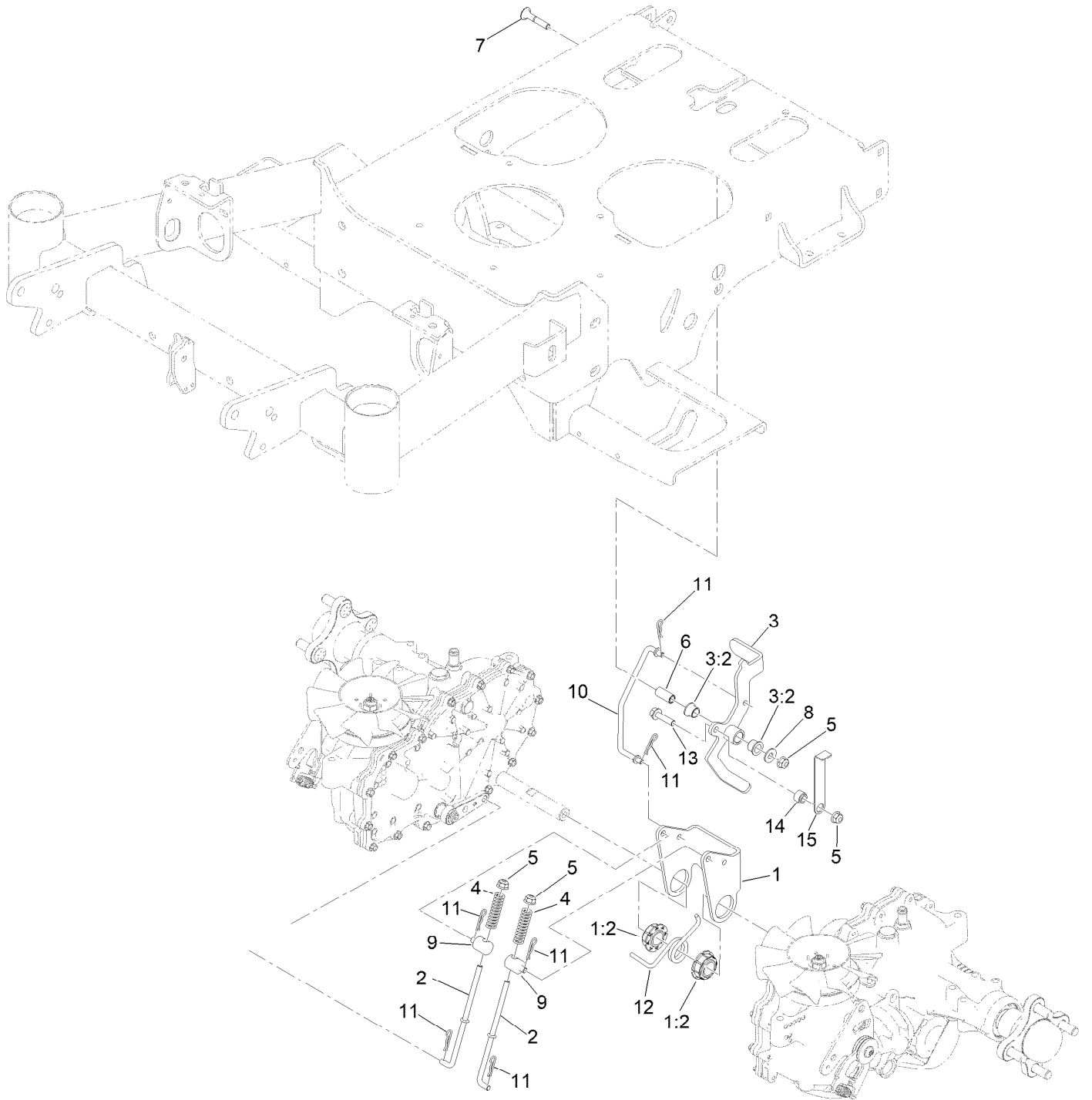



## Brake Assembly (continued)

<i>Ref.</i>	<i>Part Number</i>	<i>Qty.</i>	<i>Description</i>	<i>Ref.</i>	<i>Part Number</i>	<i>Qty.</i>	<i>Description</i>
1	142-6201	1	ASM-Brake, Bell Crank	8	HDW14535	1	Flat Washer, 5/16 Nom,ST/ST,18-8
1:2	142-4668	2	Bearing-Spherical	9	142-4646	2	Fitting-Rod
2	142-4669	2	Rod-Brake, Lower	10	142-4670	1	Rod-Brake, Upper
3	142-6202	1	ASM-Brake, Handle	11	1-806003	6	Pin-Cotter
3:2	116-4279	2	Bearing-Flange	12	142-4713	1	Spring-Torsion
4	142-4712	2	Spring-Compression	13	135-6261	1	Screw-HHF
5	135-6109	4	Nut-Hex Flange	14	142-6198	1	Spacer-Brake, Interlock
6	142-4674	1	Spacer-Brake	15	142-6197	1	Plate-Brake, Interlock
7	131-9663	1	Screw-CARR				

# Electrical Assembly

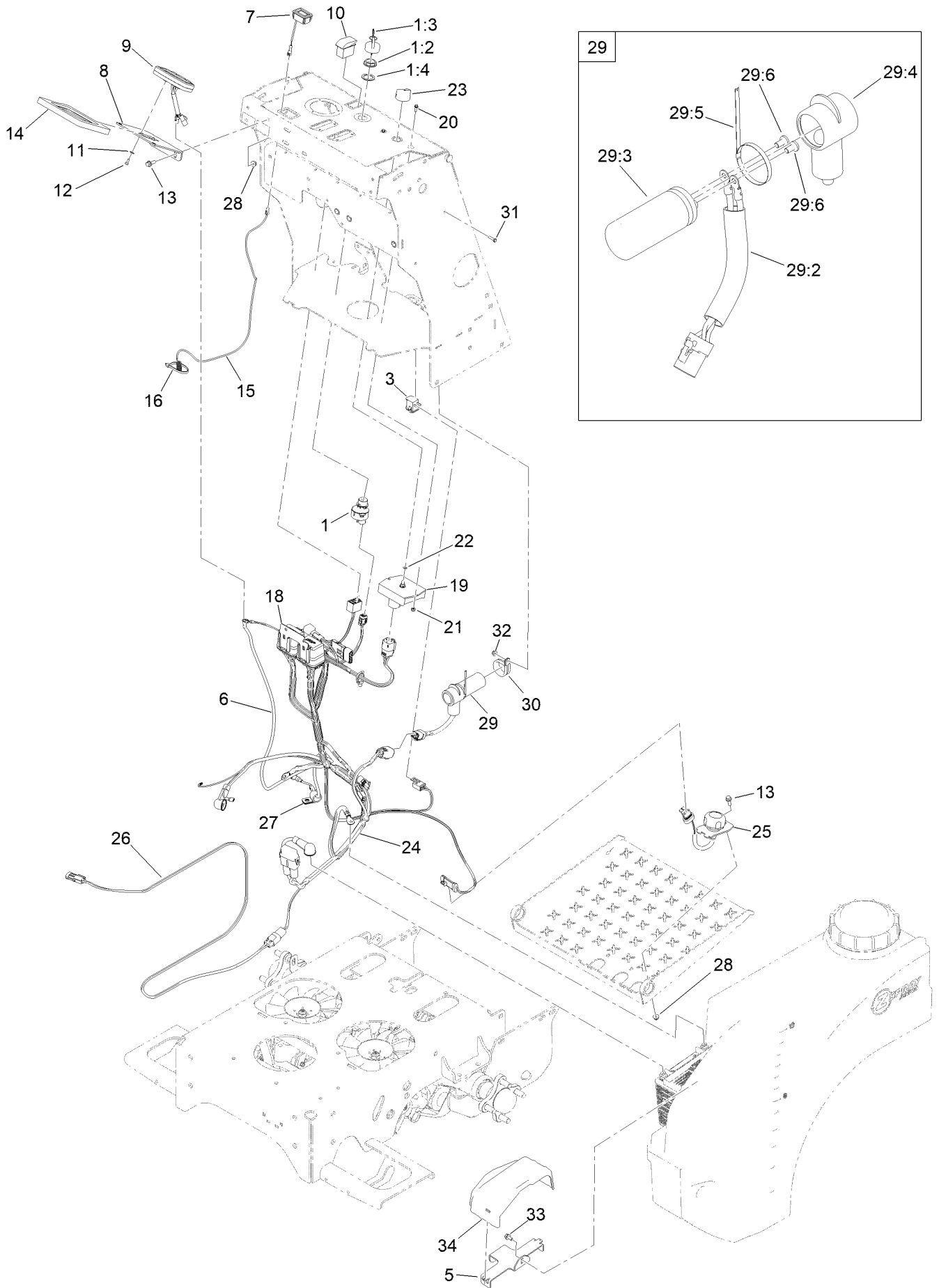

## Electrical Assembly (continued)

<i>Ref.</i>	<i>Part Number</i>	<i>Qty.</i>	<i>Description</i>	<i>Ref.</i>	<i>Part Number</i>	<i>Qty.</i>	<i>Description</i>
1	126-6285	1	Ignition Switch ASM	22	360-0497	1	O-Ring
1:2	108-8660	1	Nut-Mounting	23	142-7061	1	Knob-Indicating
1:3	106-5270	1	Ignition Key Set	24	142-7364	1	Harness-Jr36
1:4	108-8659	1	Washer-Backup	25		1	Switch-Foot ■
3	82-2190	1	Switch-Bail	26	142-7224	1	Harness-Spreader Motor
5	142-7882	1	Strap-Battery	27	1-633396	1	Clip-Loom
6	135-8898	1	Cable-Sensor, Trail Tech	28	135-6108	3	Nut-Hex Flange
7	135-5259	1	Meter-Tach/Hour	29	142-9333	1	Harness-Capacitor
8	142-5553-05	1	Mount-Display	29:2	32180-213	1	Tubing, Conv, 5/8", Hi Temp, Uv Inhibit ●
9	135-8900	1	Striker-Head Only	29:3	142-8083	1	Cap, 36000Uf 40V
10	100-8469	1	Switch-Rocker	29:4	142-9340	1	Boot-Capacitor
11	126-0759	2	Washer-Flat	29:5	32181-017	1	Tie-Stainless
12	135-6357	2	Screw-HSH	29:6	47-2830	2	Screw
13	135-6221	3	Screw-HHF	30	142-8944	1	Clamp-R, Cushion
14	142-6690	1	Pad-Display Mount	31	135-6356	1	Screw-HH
15	135-6118	1	Wire-Tachometer	32	135-6342	1	Nut-Hex Flange
16	3290-378	1	Tie-Cable	33	142-5490	1	Screw-HWH, Patch
18	142-7313	1	Bracket-Cover, Fuse	34	146-0151	1	Cover-Battery
19	142-6905	1	Controller-Motor, Spreader	99	135-7317	1	Manual-User, Striker ●
20	112-3169	2	Screw-HHF, Serrated	99	135-7318	1	Card-Striker, Quick Start ●
21	520-0006	2	Nut-Hex, Nylock				

● Not illustrated

■ Not serviced separately

# Foot Switch Assembly

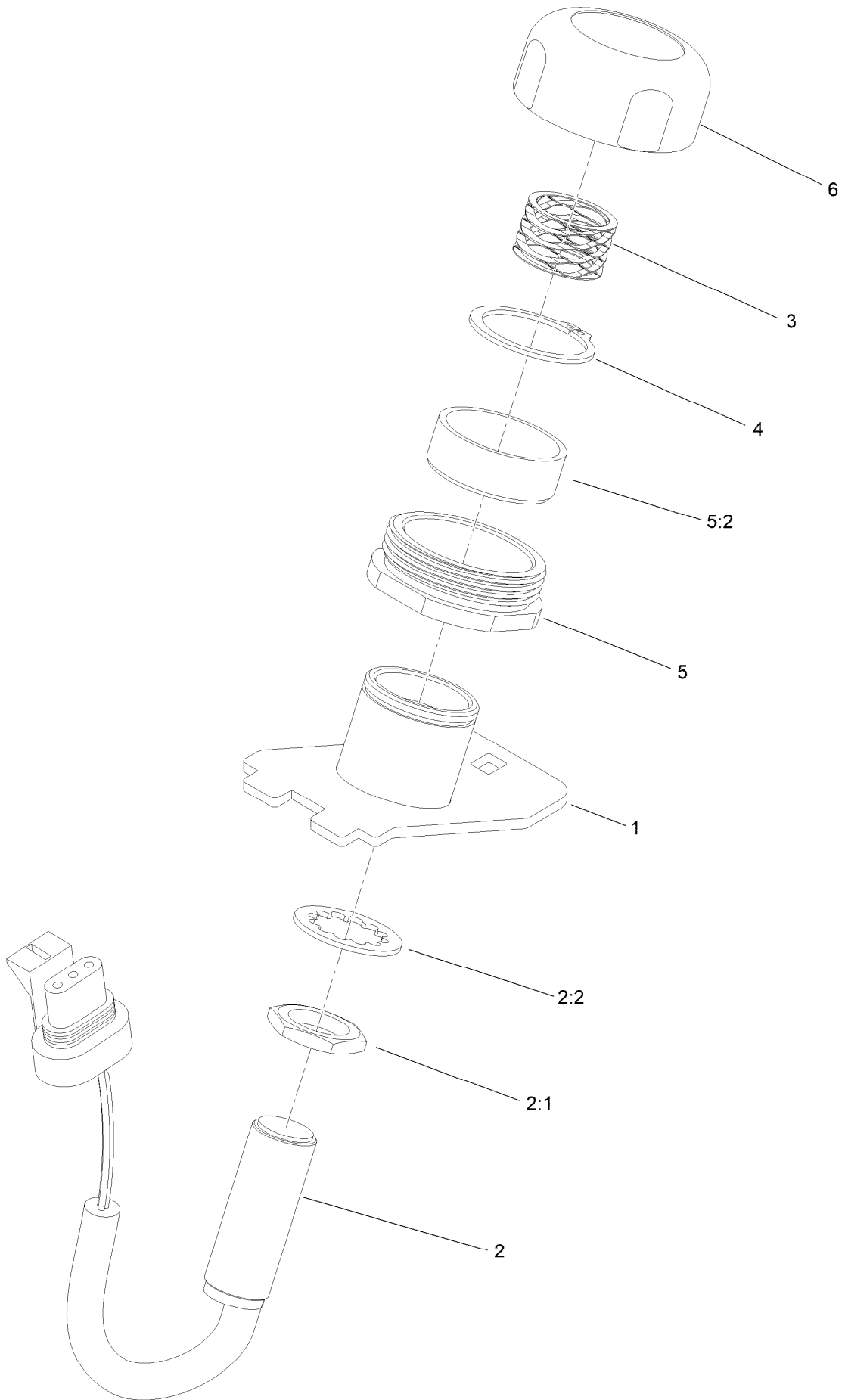

## Foot Switch Assembly (continued)

<i>Ref.</i>	<i>Part Number</i>	<i>Qty.</i>	<i>Description</i>	<i>Ref.</i>	<i>Part Number</i>	<i>Qty.</i>	<i>Description</i>
1	142-9322	1	Mount-Switch, Foot	4	142-9329	1	Ring-Retaining, EXT
2	115-5300	1	Proximity Switch ASM	5	142-9330	1	Guide-Button
2:1	117-3207	2	Nut-Hex	5:2	142-9326	1	Bushing-Sleeve
2:2	117-3208	2	Washer-Lock, Internal Tooth	6	142-9327	1	Button-Foot
3	142-9328	1	Spring-Wave				

# Controls Assembly

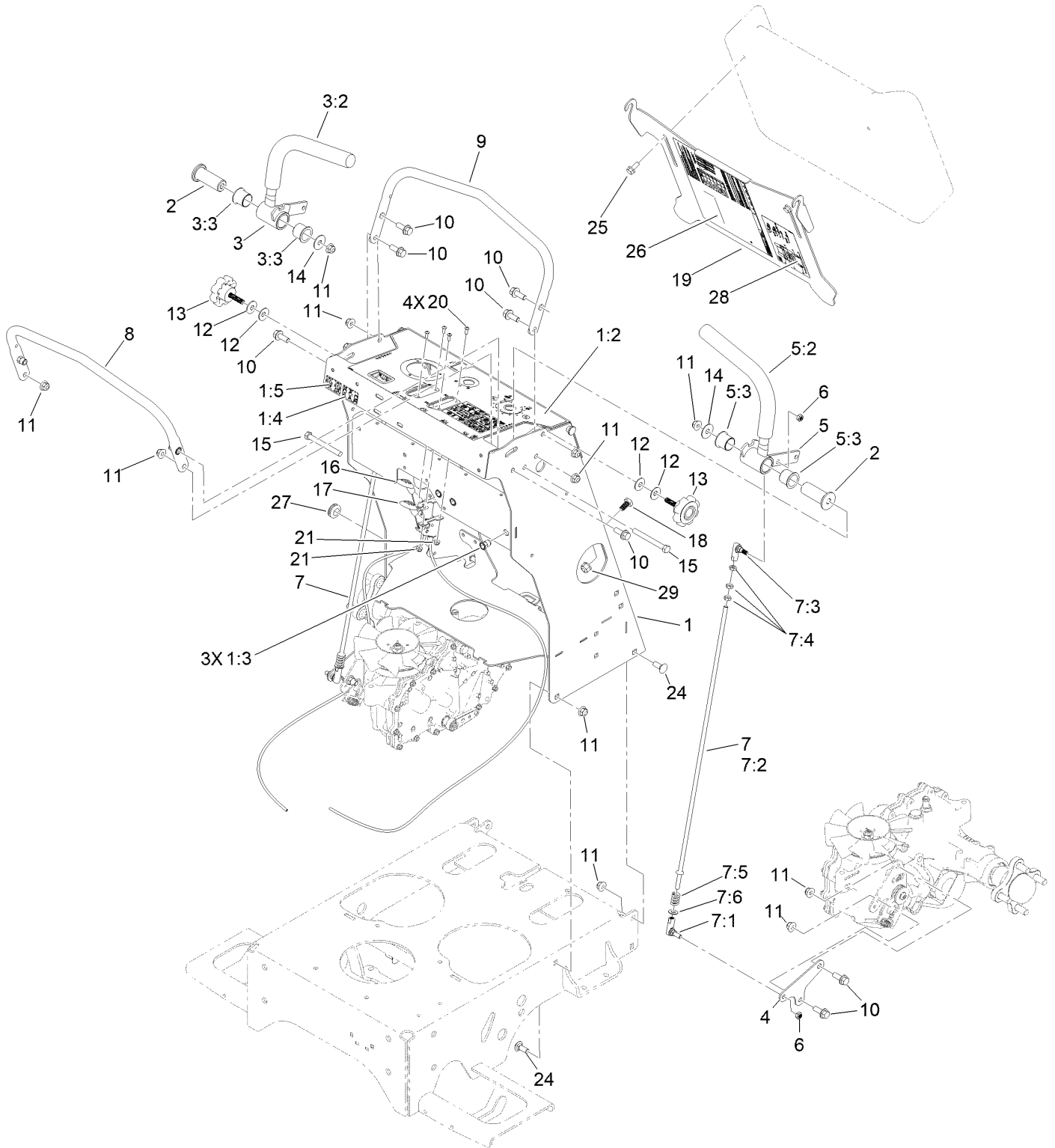

## Controls Assembly (continued)

<i>Ref.</i>	<i>Part Number</i>	<i>Qty.</i>	<i>Description</i>	<i>Ref.</i>	<i>Part Number</i>	<i>Qty.</i>	<i>Description</i>
1	142-7599	1	Tower-ASM W/Decal	8	142-7601	1	Bar-Speed, ASM
1:2	142-8355	1	Decal-Control Panel	9	142-7600-05	1	Bar-Reference
1:3	142-7574	3	Nut-Clinch,Hex	10	135-6208	10	Screw-HHF
1:4	142-8079	1	Decal-Fuse,Main	11	135-6110	16	Nut-Hex Flange
1:5	142-8081	1	Decal-Fuse,Solid State	12	3290-461	4	Washer-Spring
2	142-4200	2	Pivot-Control, Handle	13	142-5494	2	Knob-Fluted
3	142-3696	1	Handle-Control, RH ASM	14	HDW19385	2	Washer-Flat
3:2	1-633257	1	Grip-Control, Motion	15	HDW17725	2	HHCS,3/8-16X3-1/2,ST/ST 18-8
3:3	126-1963	2	Bushing-Pivot	16	142-6693	1	Control-Throttle
4	142-6192	2	Arm-Control, Rtn	17	109-8747	1	Control,Choke
5	142-3697	1	Handle-Control, LH ASM	18	142-7585	2	Magnet-Stud, Threaded
5:2	1-633257	1	Grip-Control, Motion	19	142-9349-05	1	Plate-Knee Pad [blk-Txt]
5:3	126-1963	2	Bushing-Pivot	20	135-6374	4	Screw-HSBH
6	142-5498	4	Nut-Lock, NI	21	135-6342	4	Nut-Hex Flange
7	142-4625	2	Linkage-Motion Control ASM	24	126-0980	4	Screw-CARR
7:1	135-5257	1	Balljoint-SS	25	126-2712	2	Screw-HHF
7:2	142-4626	1	Rod-Control, Motion	26	146-0776	1	Decal-Spray Chart
7:3	135-9812	1	Balljoint-SS	27	112-7069	1	Grommet
7:4	107-0282	3	Nut-Hex	28	142-8050	1	Decal-Service Aid
7:5	142-6894	1	Spring-Compression	29	103-9511	2	Nut-Flg
7:6	107-0279	1	Washer				

# Tire Assembly

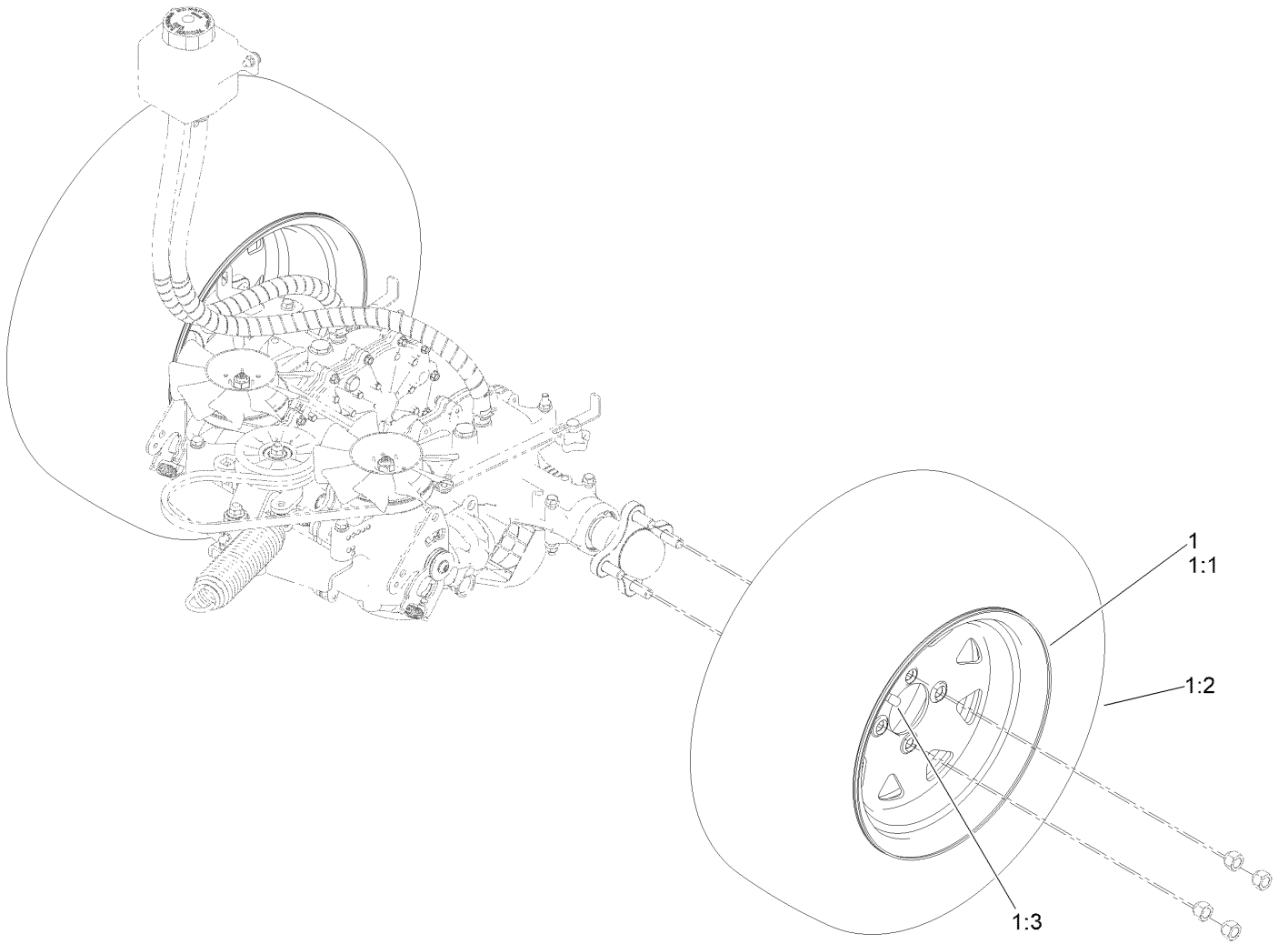



## Tire Assembly (continued)

<i>Ref.</i>	<i>Part Number</i>	<i>Qty.</i>	<i>Description</i>	<i>Ref.</i>	<i>Part Number</i>	<i>Qty.</i>	<i>Description</i>
1	142-5569	2	Wheel And Tire ASM	1:2	135-6093	1	Tire
1:1	142-5570	1	Wheel	1:3	232-27	1	Stem-Valve

# Caster Wheels Assembly

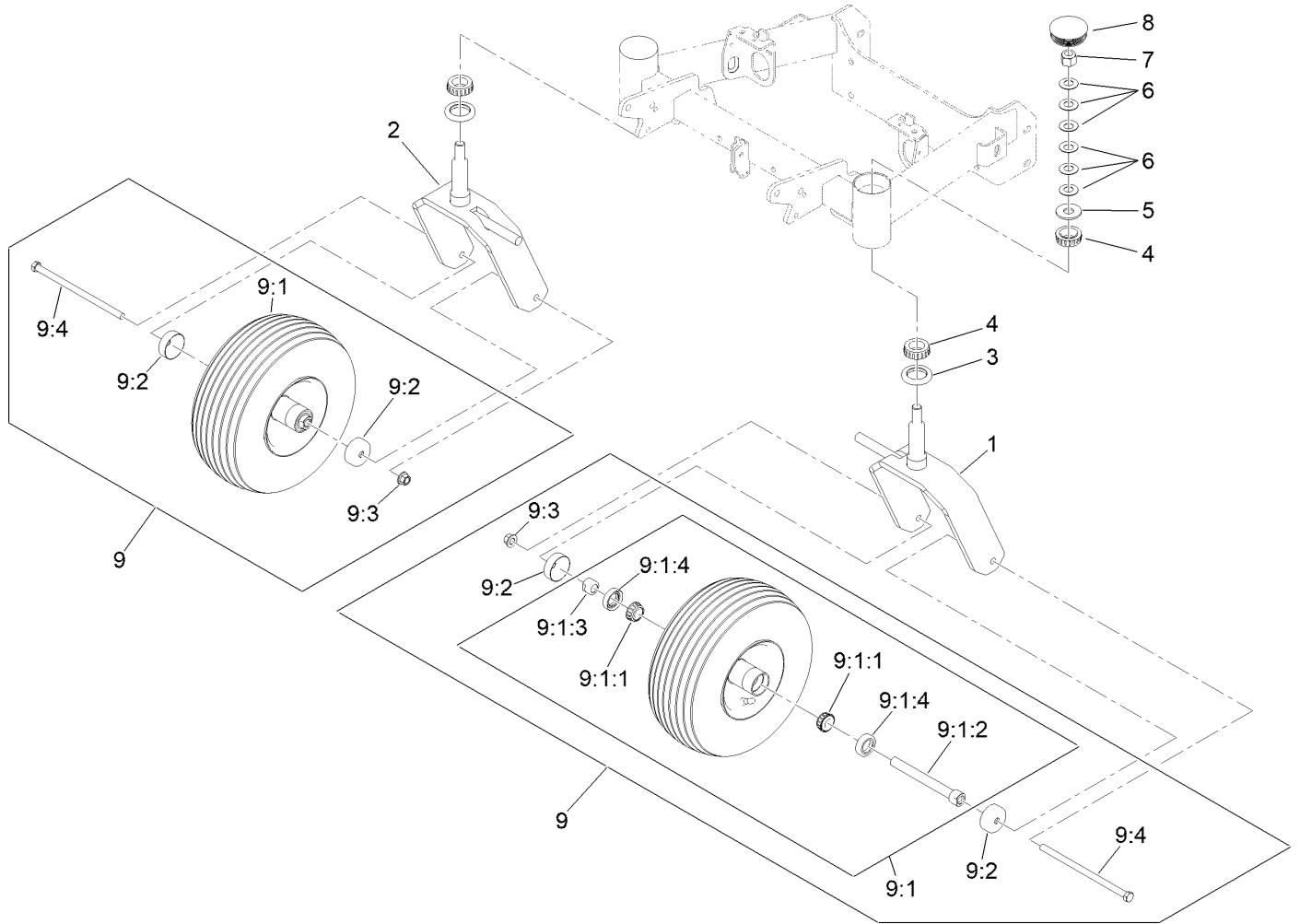

## Caster Wheels Assembly (continued)

<i>Ref.</i>	<i>Part Number</i>	<i>Qty.</i>	<i>Description</i>	<i>Ref.</i>	<i>Part Number</i>	<i>Qty.</i>	<i>Description</i>
1	142-4545-05	1	Weld-Caster, LH [blk-Txt]	9:1		1	ASM-Whl And Tire ●
2	142-4547-05	1	Weld-Caster, RH [blk-Txt]	9:1:1	1-633585	2	Bearing-Cone, Taper
3	135-0355	2	Seal-Grease	9:1:2	126-5361	1	Axle Caster ASM
4	103-9028	4	Bearing-Roller, Cone Taper	9:1:3	103-3051	1	Spacer-Nut
5	3256-8	2	Washer-Flat	9:1:4	103-0063	2	Seal-Caster
6	1-633508	12	Washer-Bellville	9:2	103-2768	2	Guard-Seal
7	3296-51	2	Nut-Lock, NI	9:3	99-5107	1	Nut-Lock
8	142-7588	2	Cap-Tube, Caster	9:4	325-39	1	Screw-HH
9	142-8942	2	ASM-Whl And Tire W/Axle				

● Not serviced separately

# Fuel Tank Assembly

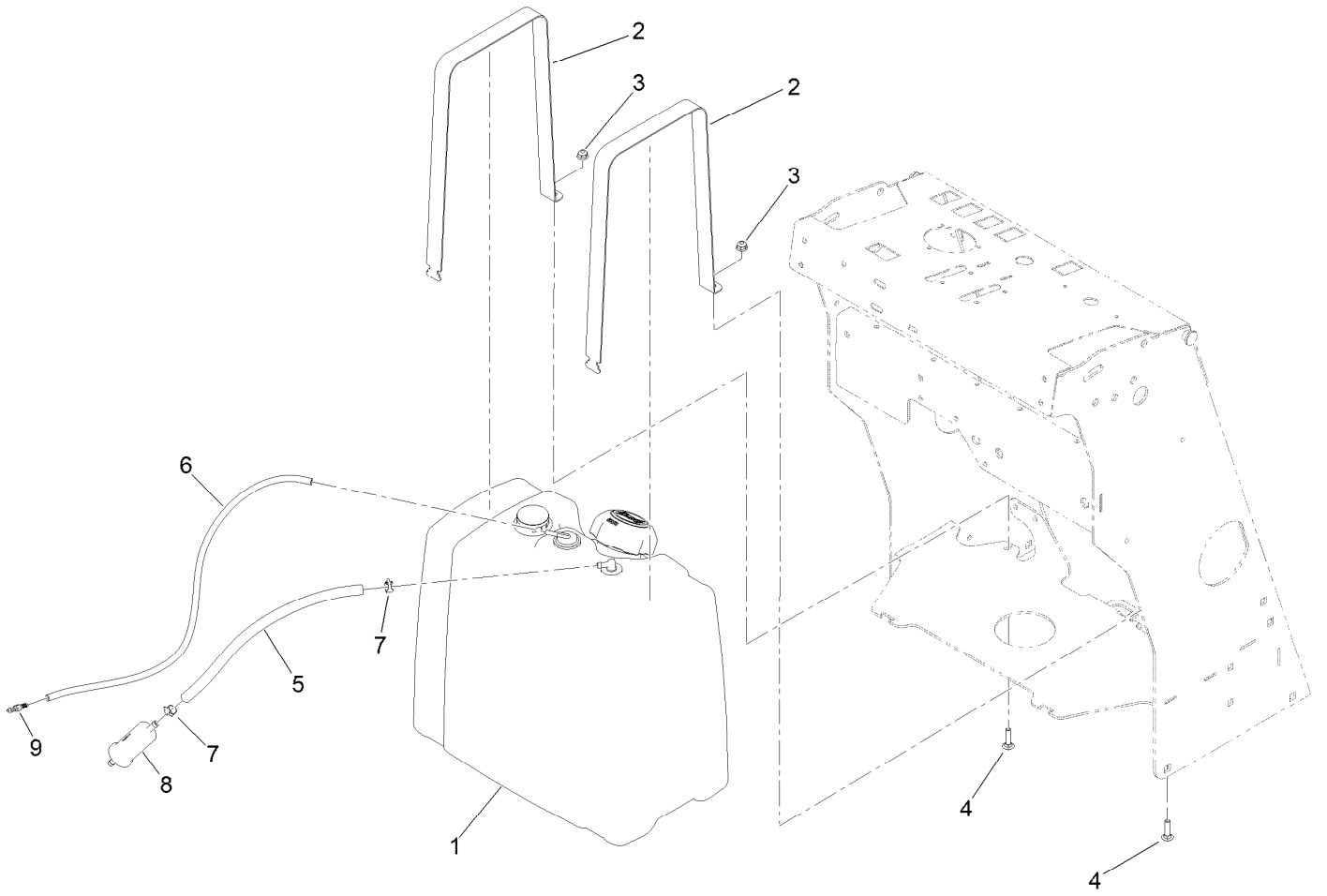

## Fuel Tank Assembly (continued)

<i>Ref.</i>	<i>Part Number</i>	<i>Qty.</i>	<i>Description</i>	<i>Ref.</i>	<i>Part Number</i>	<i>Qty.</i>	<i>Description</i>
1	142-7602	1	ASM-Tank, Fuel	6	110-8255	1	Hose-Fuel
2	142-7332	2	Strap-Tank	7	2412-98	2	Clamp-Hose
3	135-6108	2	Nut-Hex Flange	8	135-6687	1	Filter-Fuel
4	126-1455	2	Screw-CARR	9	120-1996	1	Fitting-STR
5	109-0297	1	Hose-Fuel				

# Fuel Tank Assembly No. 142-7602

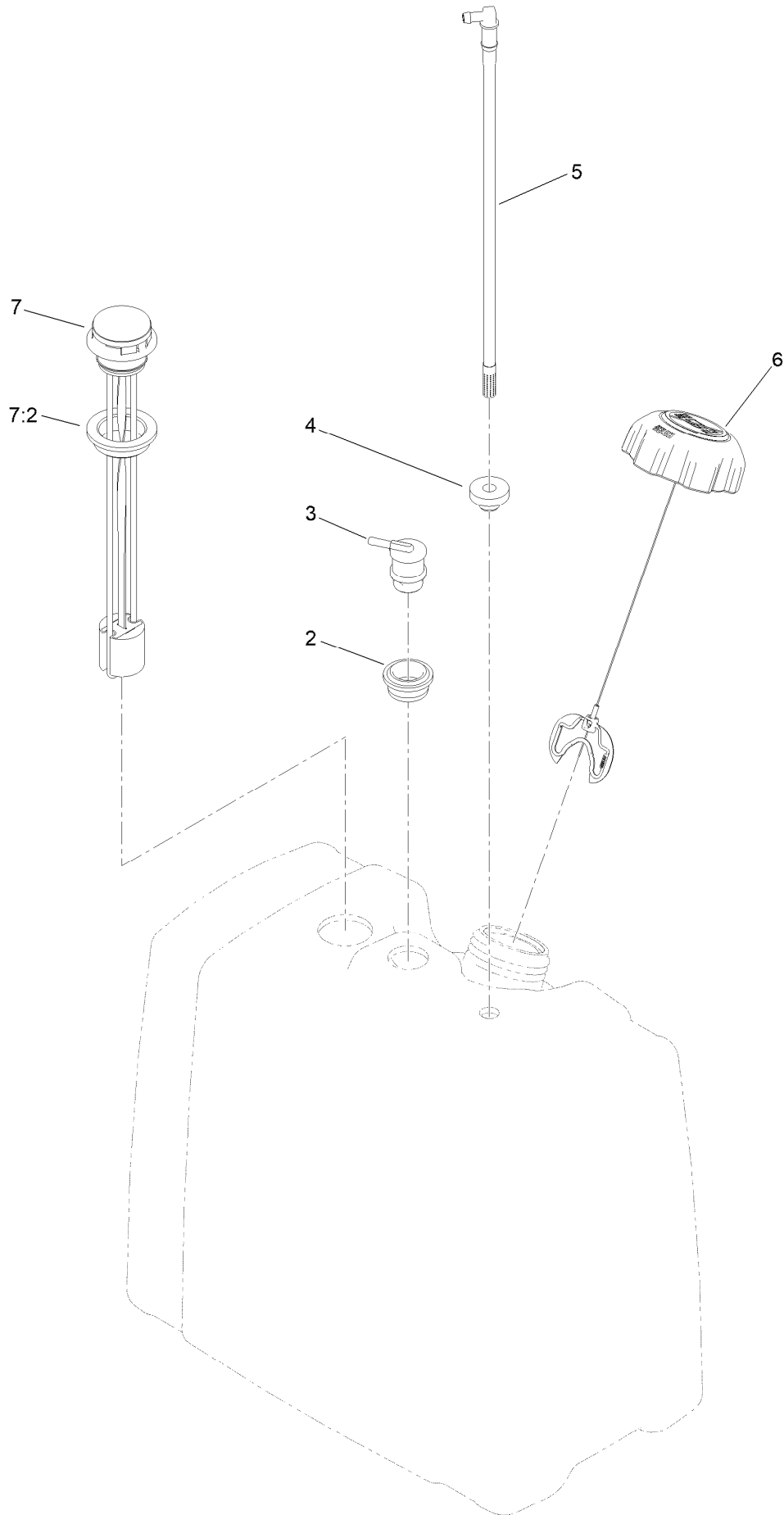

## Fuel Tank Assembly No. 142-7602 (continued)

<i>Ref.</i>	<i>Part Number</i>	<i>Qty.</i>	<i>Description</i>	<i>Ref.</i>	<i>Part Number</i>	<i>Qty.</i>	<i>Description</i>
2	114-0284	1	Grommet	6	137-4127	1	Cap-Fuel
3	119-3547	1	Valve-Vent, Fuel	7	119-0509	1	Gauge ASM
4	46-6560	1	Bushing	7:2	119-0508	1	Seal
5	115-9044	1	Pipe-Stand				

# Spreader Assembly

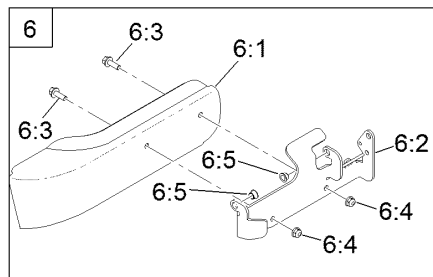
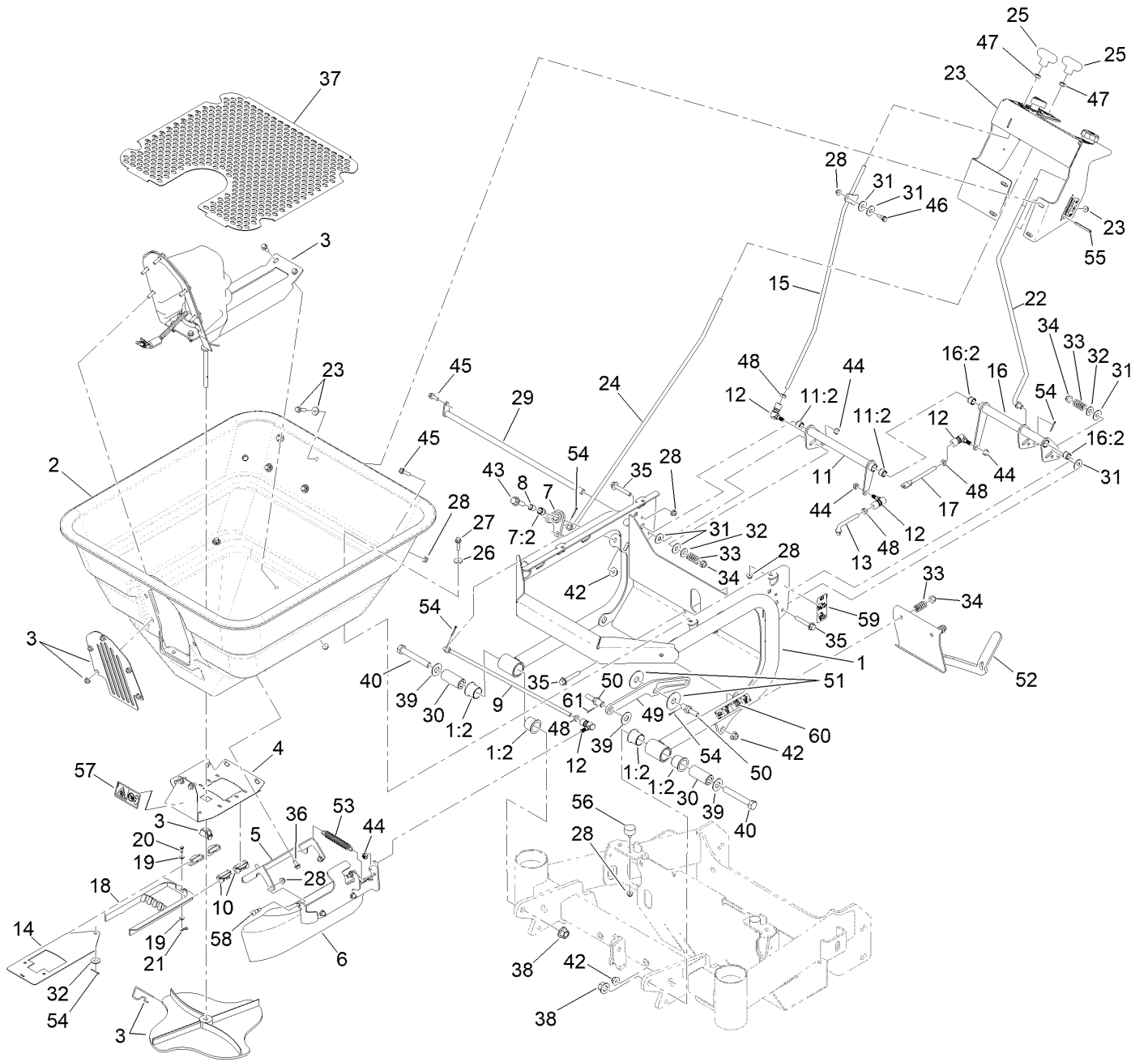



## Spreader Assembly (continued)

<i>Ref.</i>	<i>Part Number</i>	<i>Qty.</i>	<i>Description</i>	<i>Ref.</i>	<i>Part Number</i>	<i>Qty.</i>	<i>Description</i>
1	142-7344	1	Frame-Hopper	27	HDW27147	4	Screw-HHF
1:2	126-1963	4	Bushing-Pivot	28	135-6108	12	Nut-Hex Flange
2	142-4649	1	Hopper -150 Lb	29	142-4031	1	Shaft-Control, Hopper
3		1	ASM-Motor, Hopper ●	30	142-4293	2	Spacer-Pivot, Hopper
4	142-3991	1	Plate-Hopper, Bottom	31	93-1633	6	Washer
5	142-7872	1	Bracket-Hopper Deflector	32	HDW14535	3	Flat Washer, 5/16 Nom,ST/ST,18-8
6		1	ASM-Deflector, Side ●	33	142-6894	4	Spring-Compression
6:1	146-0145	1	Chute-Deflector	34	135-6109	4	Nut-Hex Flange
6:2	146-0146	1	Bracket-Deflector, Side	35	126-2711	4	Screw-HHF
6:3	135-6221	2	Screw-HHF	36	142-5490	8	Screw-HWH, Patch
6:4	135-6108	2	Nut-Hex Flange	37	142-4696	1	Screen-Hopper, Medium
6:5	138-5538	2	Bushing-Flange	38	135-6111	2	Nut-Hex Flange
7	142-7614	1	Crank-Defelctor	39	HDW14428	3	Washer
7:2	142-3932	1	Bushing	40	142-7326	2	Screw-HH
8	142-7618	1	Bushing-Pivot, Deflector	42	135-6110	3	Nut-Hex Flange
9	142-3961	1	Linkage-Deflector, Lower	43	135-6211	1	Screw-HHF
10	142-3316	4	Guide-Rate, Gate	44	142-5498	4	Nut-Lock, NI
11	142-3927	1	Crank-Gate, Hopper	45	135-6221	3	Screw-HHF
11:2	142-3932	2	Bushing	46	42-3560	1	Bolt-Shoulder
12	135-5718	4	Ball Joint-Quick Disconnect, SS	47	363-1684	2	Nut-Hex
13	142-3933	1	Linkage-Gate, Lower	48	107-0282	4	Nut-Hex
14	142-3942	1	Rate-Gate	49	142-6891	1	Strap-Hopper
15	142-8937	1	Linkage-Gate, Upper	50	142-6892	2	Pin-Pivot
16	142-3946	1	Crank-Diffuser	51	142-7591	2	Washer-Flat, 1/2, SS
16:2	142-3932	2	Bushing	52	142-7495-05	1	Latch-Hopper [blk-Txt]
17	142-3949	1	Linkage-Diffuser, Lower	53	142-8921	1	Spring-Extension
18	142-3406	1	Diffuser	54	HDW14430	4	Cotter Pin 5/64X3/4 18-8
19	126-0759	2	Washer-Flat	55	142-7053	1	Pin-Roll, 3/16 X 2.0
20	126-3729	1	Pin-Clevis	56	240-14	2	Bumper-Rubber
21	126-1631	1	Pin-Hair	57	135-6725	1	Decal-Dismemberment Hazard
22	142-8939	1	Linkage-Diffuser, Upper	58	119-4881	2	Bolt-Shoulder
23		1	ASM-Console, Hopper ●	59	146-0725	1	Decal-Hopper Rotate
24	142-8936	1	Linkage-Deflector, Upper	60	146-1742	1	Decal-Hopper Latch
25	142-5558	2	Knob-T	61	132-0707	2	Pin-Cotter
26	135-6341	4	Washer				

● Not serviced separately

# Hopper Motor Assembly

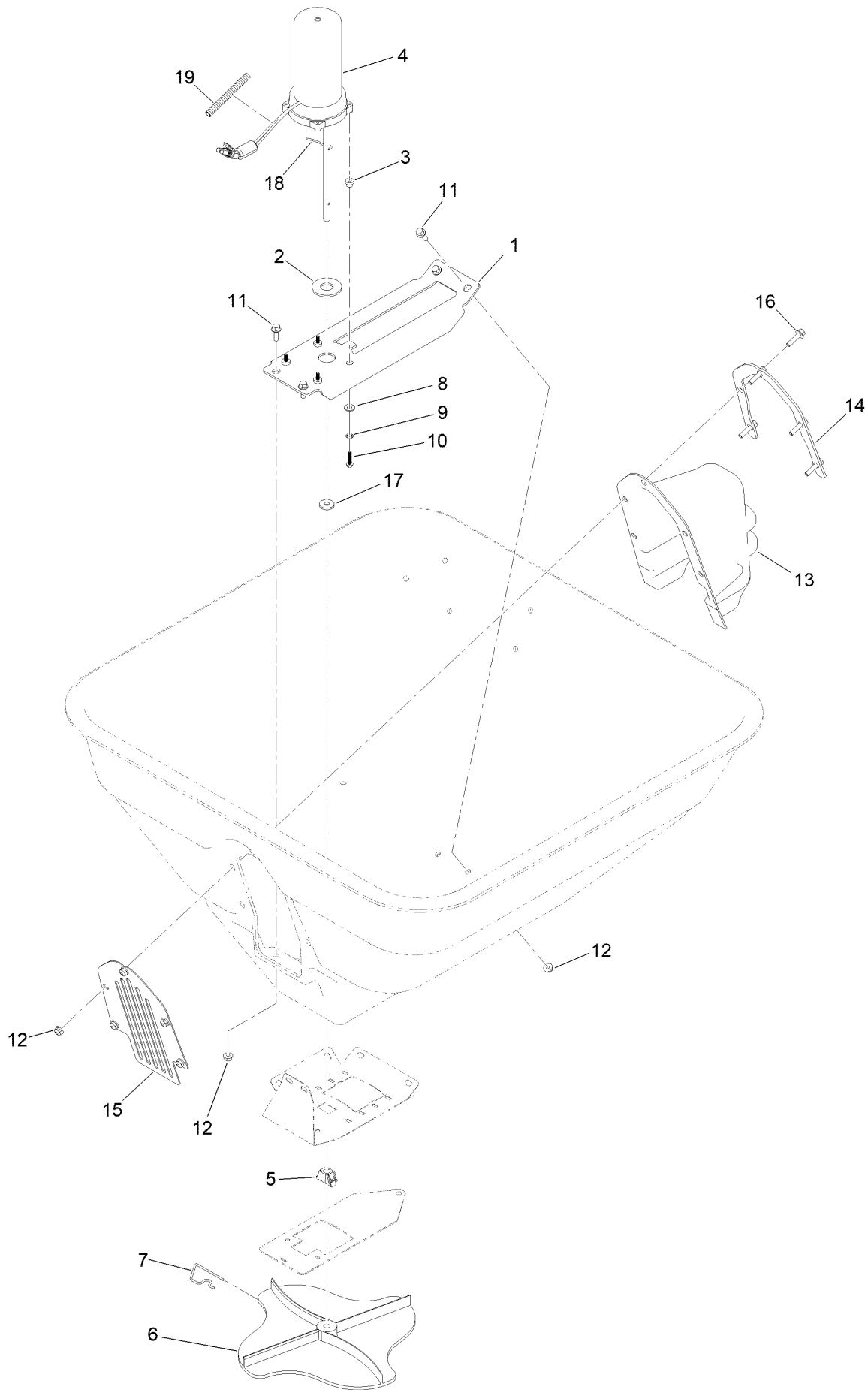

## Hopper Motor Assembly (continued)

<i>Ref.</i>	<i>Part Number</i>	<i>Qty.</i>	<i>Description</i>	<i>Ref.</i>	<i>Part Number</i>	<i>Qty.</i>	<i>Description</i>
1	142-4686	1	Bracket-Mount, Motor	11	135-6221	4	Screw-HHF
2	83-2400	1	Spacer	12	135-6108	9	Nut-Hex Flange
3	135-3989	4	Spacer-Flanged	13	142-8924	1	Cover-Motor
4	126-0379	1	Motor-Spreader	14	126-6334	1	Flange-Cover, Motor
5	142-4042	1	Hopper Bottom Bearing	15	142-4721	1	Cover-Front, Motor
6	142-3506	1	Spinner-Spreader	16	HDW27147	5	Screw-HHF
7	142-3541	1	Clip-Spinner	17	142-3665	1	Washer-Felt
8	360-0140	4	Washer-Flat	18	142-3666	1	Wire-Agitator
9	363-8641	4	Washer-Lock, Int	19	142-6683	1	Loom-Split
10	739001	4	Screw-SHWH				

# Hopper Console Assembly

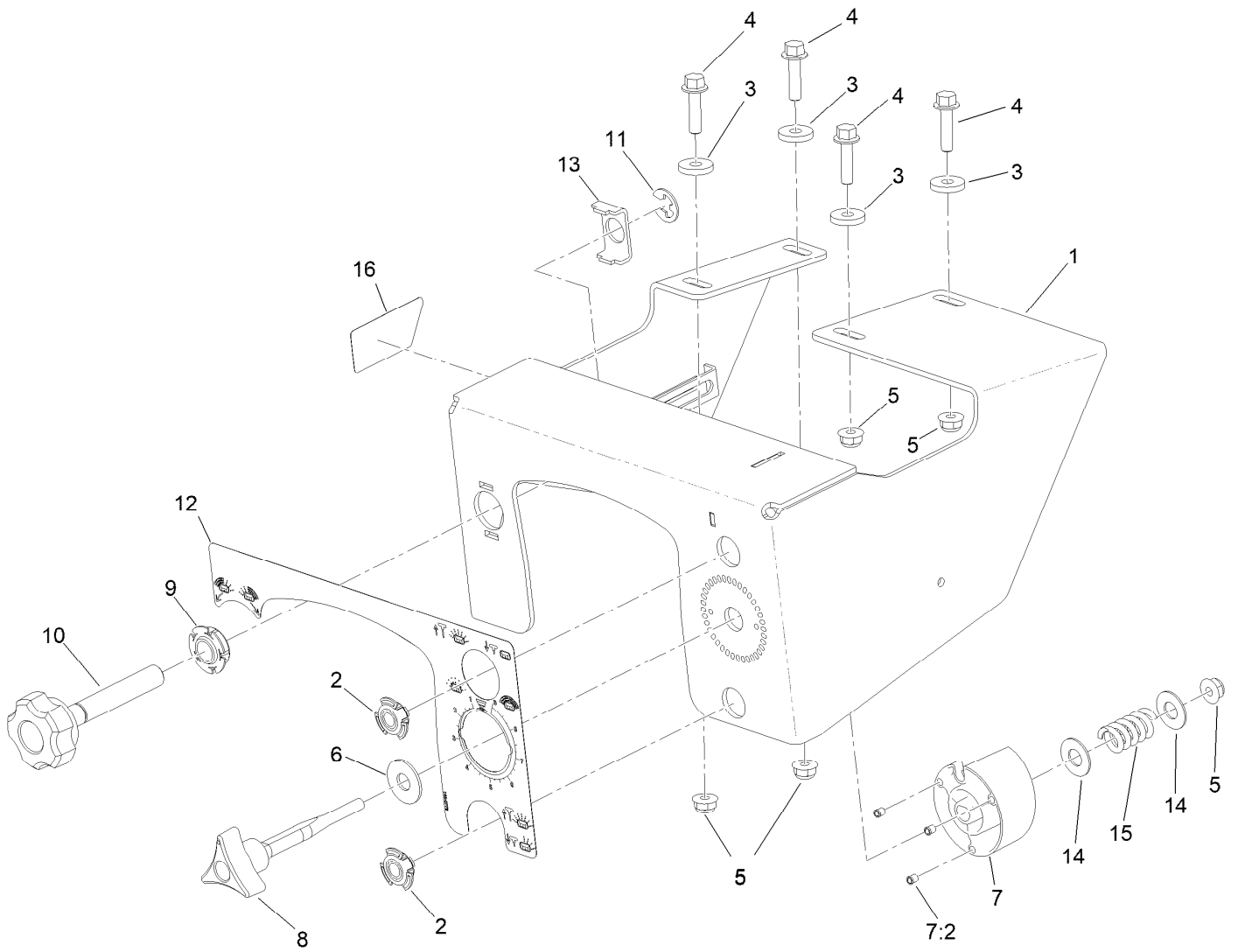

## Hopper Console Assembly (continued)

<i>Ref.</i>	<i>Part Number</i>	<i>Qty.</i>	<i>Description</i>	<i>Ref.</i>	<i>Part Number</i>	<i>Qty.</i>	<i>Description</i>
1	142-8934	1	Console-Hopper Jr36	9	126-5820	1	Bearing-Spherical
2	142-3955	2	Bearing-Spherical	10	142-7037	1	Knob-Diffuser
3	135-6341	4	Washer	11	142-4698	1	Ring-E
4	HDW27147	4	Screw-HHF	12	146-0773	1	Decal-Console
5	135-6108	5	Nut-Hex Flange	13	142-7054	1	Stop-Diffuser
6	93-1633	1	Washer	14	HDW05859	2	Washer,Flat,3/8ST/ST 18-8
7	142-4642	1	Dial-Rate	15	142-6894	1	Spring-Compression
7:2	142-4641	3	Plunger-Spring, Ball	16	142-9684	1	Decal-Pattern Indicator
8	142-7035	1	Knob-Rate				

# Sprayer Tanks Assembly

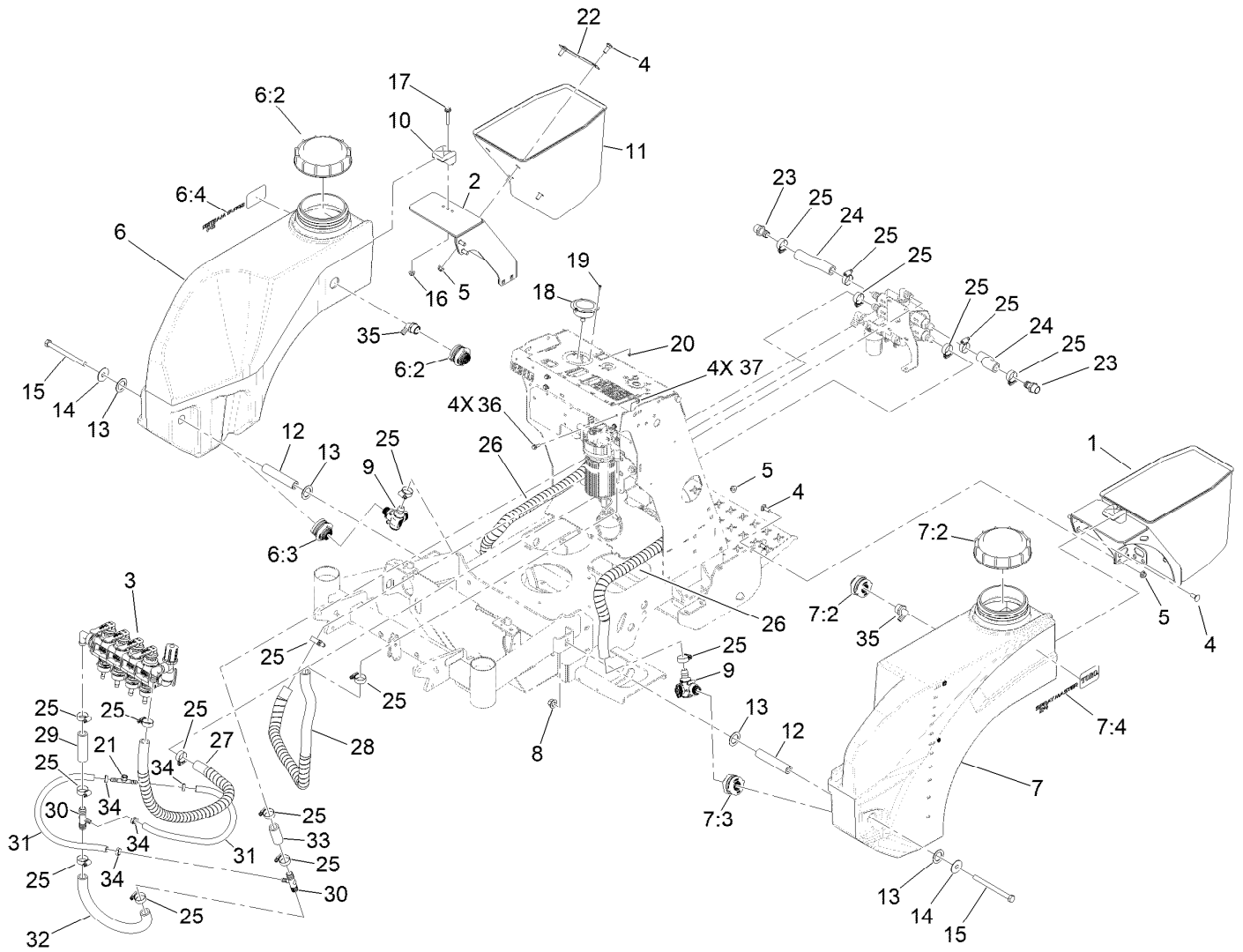

## Sprayer Tanks Assembly (continued)

<i>Ref.</i>	<i>Part Number</i>	<i>Qty.</i>	<i>Description</i>	<i>Ref.</i>	<i>Part Number</i>	<i>Qty.</i>	<i>Description</i>
1	142-6357	1	Fender-Lt	17	126-2711	2	Screw-HHF
2	142-6359	1	Fender-Rt	18	126-4110	1	Gauge-Pressure
3	142-7050	1	ASM-Manifold, Spray	19	135-6357	3	Screw-HSH
4	126-0980	16	Screw-CARR	20	140-3749	3	Nut-Lock Rohs
5	135-6110	16	Nut-Hex Flange	21	126-2348	1	Fitting-Tee
6	142-7857	1	Tank-12Gal, Rt	22	142-6890	4	Plate-Backing, Fert Box
6:2	135-5916	1	Cap-Tank, Spray	23	41257	2	Hosebarb
6:3	126-4393	2	Fitting-Bulkhead	24	142-7056	2	Hose-Return
6:4	142-9318	1	Decal-Spraymaster, 24	25	2412-129	18	Clamp-Hose
7	142-7859	1	Tank-12Gal, Lt	26	142-7080	2	Hose-Spray, Wrapped
7:2	135-5916	1	Cap-Tank, Spray	27	142-7613	1	Hose-Spray, Wrapped
7:3	126-4393	2	Fitting-Bulkhead	28	135-7087	1	Hose-Spray, Wrapped
7:4	142-9317	1	Decal-Spraymaster, 24	29	142-6907	1	Hose-Spray
8	135-6111	2	Nut-Hex Flange	30	142-4450	2	Tee-Hose Barb
9	142-4468	2	Valve-3 Way	31	142-7062	2	Hose-Spray
10	107-4543	2	Clamp	32	135-6164	1	Hose-Spray
11	142-6364	2	Box-Fertilzer, Jr36	33	142-7066	1	Hose-Spray
12	142-6361	2	Spacer-Tank	34	135-5757	4	Clamp-Oetiker, 167
13	131-5905	4	Washer-Rubber	35	135-5744	2	Fitting-Elbow, 90
14	142-7591	2	Washer-Flat, 1/2, SS	36	135-6221	4	Screw-HHF
15	HDW17767	2	HHCS, 1/2-13X6 ST/ST, 18-8	37	135-6108	4	Nut-Hex Flange
16	135-6109	2	Nut-Hex Flange				

# Sprayer Manifold Assembly No. 142-7050

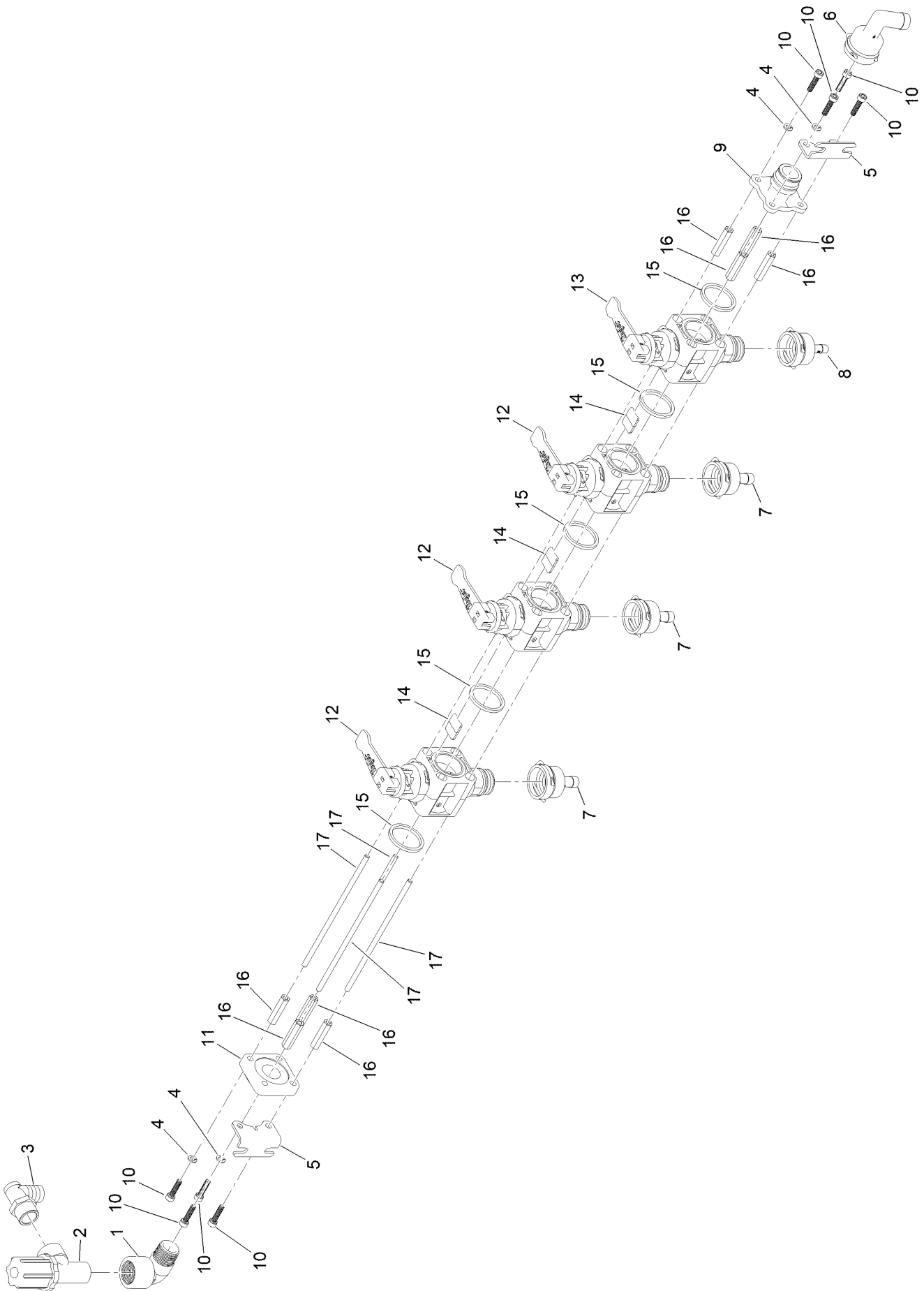



# Sprayer Manifold Assembly No. 142-7050 (continued)

<i>Ref.</i>	<i>Part Number</i>	<i>Qty.</i>	<i>Description</i>	<i>Ref.</i>	<i>Part Number</i>	<i>Qty.</i>	<i>Description</i>
1	132-7706	1	Elbow-90 DEG	10	142-6348	8	Screw-Hscs 6 MM X 25.0 MM SS
2	135-5736	1	Valve-Throttle	11	142-7041	1	Cap-End, 3/4 Npt, Female
3	135-5772	1	Fitting-Elbow, 90	12	142-7042	3	ASM-Valve Section, Grey
4	142-4415	4	Washer	13	142-7043	1	ASM-Valve Section, Black
5	142-4416	2	Bracket-Mount	14	142-7496	3	Alignment Piece
6	142-5591	1	Kit-Hose Barb, 3/4 90, Qc	15	142-7497	5	Gasket
7	142-6187	3	Kit-1/2 Hb, STR, Qc	16	142-7498	8	M6X1 Metric Hex Stand-Off
8	142-6188	1	Kit-3/8 Hb, STR, Qc	17	142-7499	4	M6X1 Threaded Rod
9	142-6347	1	Adaptor-Male Qc Bolted Flanged				

# Boom Assembly

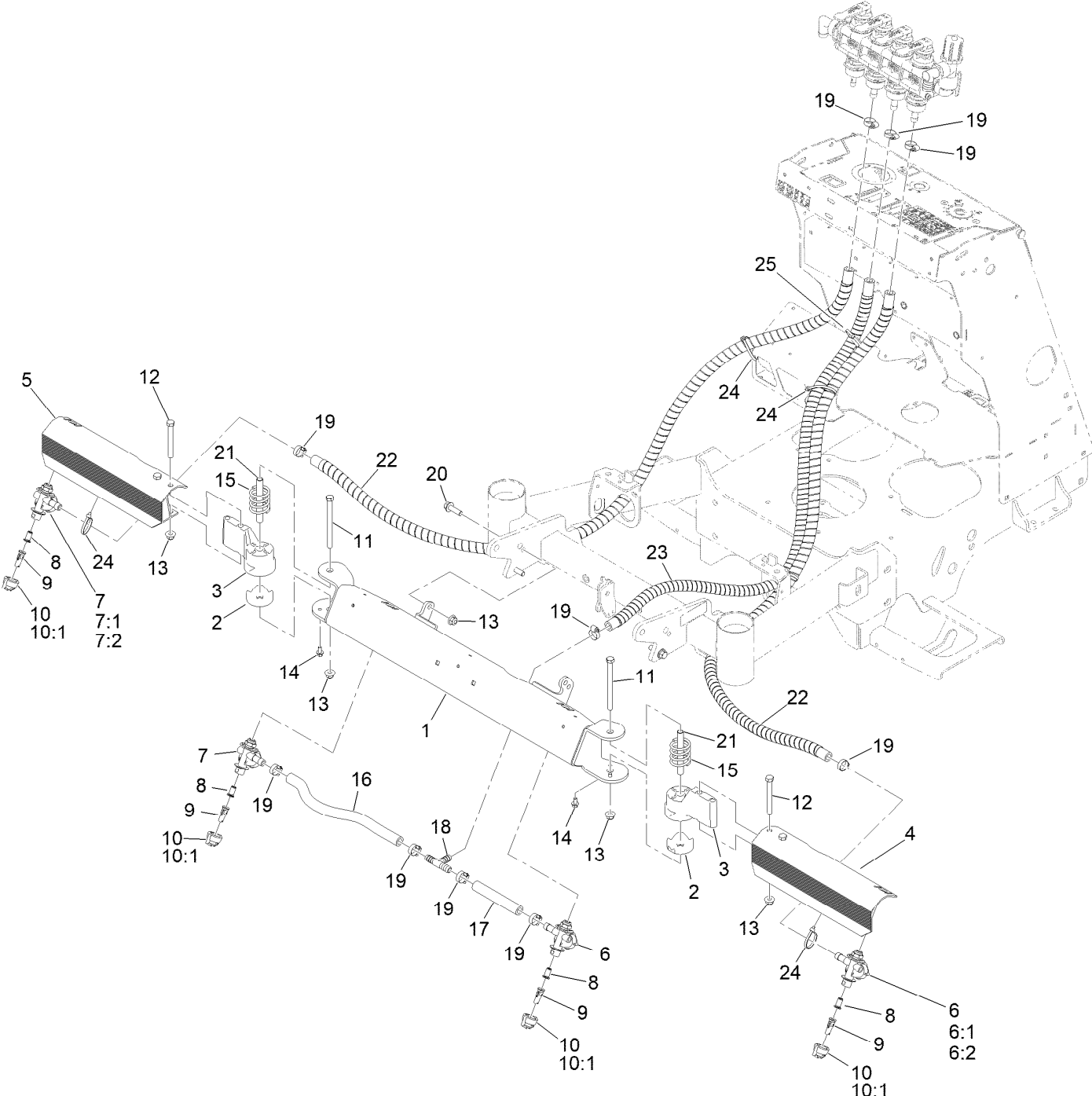

## Boom Assembly (continued)

<i>Ref.</i>	<i>Part Number</i>	<i>Qty.</i>	<i>Description</i>	<i>Ref.</i>	<i>Part Number</i>	<i>Qty.</i>	<i>Description</i>
1	142-4709	1	Boom-Center, Welded	11	142-7327	2	Screw-HH
2	142-3990	2	Boom-Pivot	12	126-2661	4	Screw-HH
3	142-6682	2	Hinge-Boom	13	135-6110	9	Nut-Hex Flange
4	142-4710	1	Boom-Wing, LH	14	142-5490	4	Screw-HWH, Patch
5	142-4711	1	Boom-Wing, RH	15	142-6880	2	Spring-Compression
6	135-5788	2	Body-Nozzle, Left	16	135-7129	1	Hose-Spray
6:1	146-1020	1	Cap-Sprayer Nozzle	17	135-6298	1	Hose-Spray
6:2	146-1021	1	Diaphragm-Sprayer Nozzle	18	126-0968	1	Fitting-Tee
7	135-5790	2	Body-Nozzle, Right	19	2412-36	10	Clamp-Hose
7:1	146-1020	1	Cap-Sprayer Nozzle	20	135-6211	3	Screw-HHF
7:2	146-1021	1	Diaphragm-Sprayer Nozzle	21	142-4069	2	Spacer-Boom, Pivot
8	126-3943	4	Strainer-Nozzle, 50M 5PSI Check	22	142-7887	2	Hose-Spray, Wrapped
9	142-3308	4	Tip-Spray, 025	23	142-7308	1	Hose-Spray, Wrapped
10	135-5781	4	Cap-Nozzle	24	3290-378	5	Tie-Cable
10:1	40998	1	Seat-Gasket	25	32180-030	1	Clip-Tie

# Pump Assembly

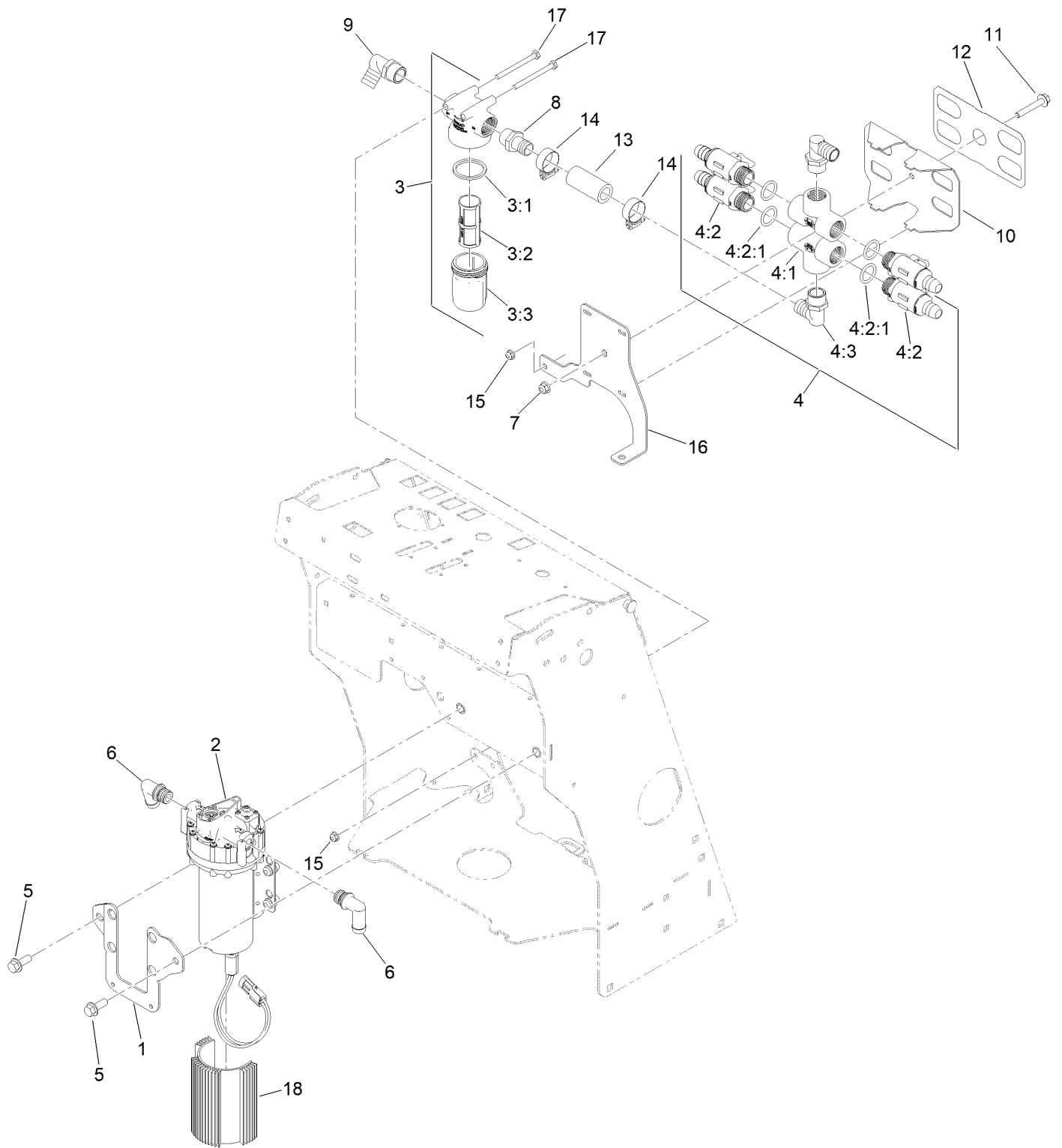

## Pump Assembly (continued)

<i>Ref.</i>	<i>Part Number</i>	<i>Qty.</i>	<i>Description</i>	<i>Ref.</i>	<i>Part Number</i>	<i>Qty.</i>	<i>Description</i>
1	142-4274	1	Bracket-Mount, Pump	7	135-6109	1	Nut-Hex Flange
2	146-0148	1	Pump-5.3 GPM	8	41257	1	Hosebarb
3	142-6864	1	Strainer-T, 50 Mesh	9	135-5772	1	Fitting-Elbow, 90
3:1	142-6867	1	Gasket-Strainer	10	142-6910	1	Bracket-Valve, Selector
3:2	142-6866	1	Screen-50 Mesh	11	126-2711	1	Screw-HHF
3:3	142-6865	1	Bowl-Strainer, Black	12	142-7247	1	Decal-Valve
4	142-6906	2	ASM-Valve, Selector	13	142-7066	1	Hose-Spray
4:1	146-0632	1	Fitting-Tee	14	2412-129	2	Clamp-Hose
4:2	142-9319	2	Valve	15	135-6108	2	Nut-Hex Flange
4:2:1	142-9320	1	O-Ring, -213	16	142-7060	1	Plate-Valve, Mount
4:3	135-5772	1	Fitting-Elbow, 90	17	HDW20122	2	HHCS, 1/4-20X3, ST/ST, 18-8
5	135-6208	2	Screw-HHF	18	142-3322	1	Heatsink-3.0 In
6	126-4420	2	Fitting-Elbow				

# Spray Gun Assembly

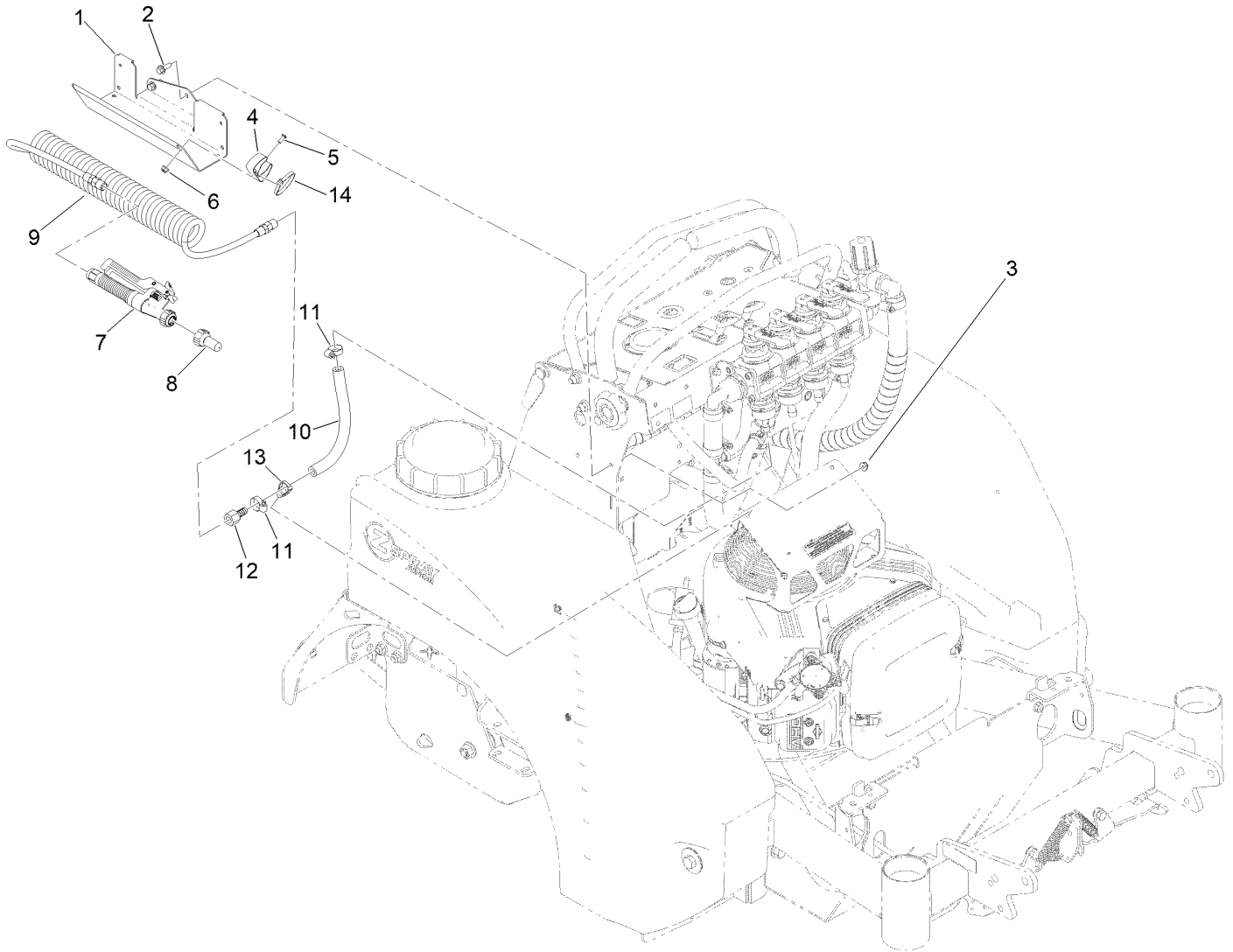

## Spray Gun Assembly (continued)

<i>Ref.</i>	<i>Part Number</i>	<i>Qty.</i>	<i>Description</i>	<i>Ref.</i>	<i>Part Number</i>	<i>Qty.</i>	<i>Description</i>
1	142-7609	1	Tray-Hose	8	135-5778	1	Tip-Spray, No.12 Spot
2	135-6221	2	Screw-HHF	9	135-6612	1	Hose-Coiled, 15 Ft
3	135-6108	2	Nut-Hex Flange	10	135-6162	1	Hose-Spray
4	135-5661	1	Holder-Tool, Clip	11	2412-36	2	Clamp-Hose
5	135-6374	1	Screw-HSBH	12	354-94	1	Fitting-Female, Barbed
6	135-6342	1	Nut-Hex Flange	13	32180-030	1	Clip-Tie
7	135-5773	1	Gun-Spray, Spot	14	3290-378	2	Tie-Cable

# Hopper Cover, Knee Pad and Battery Assembly

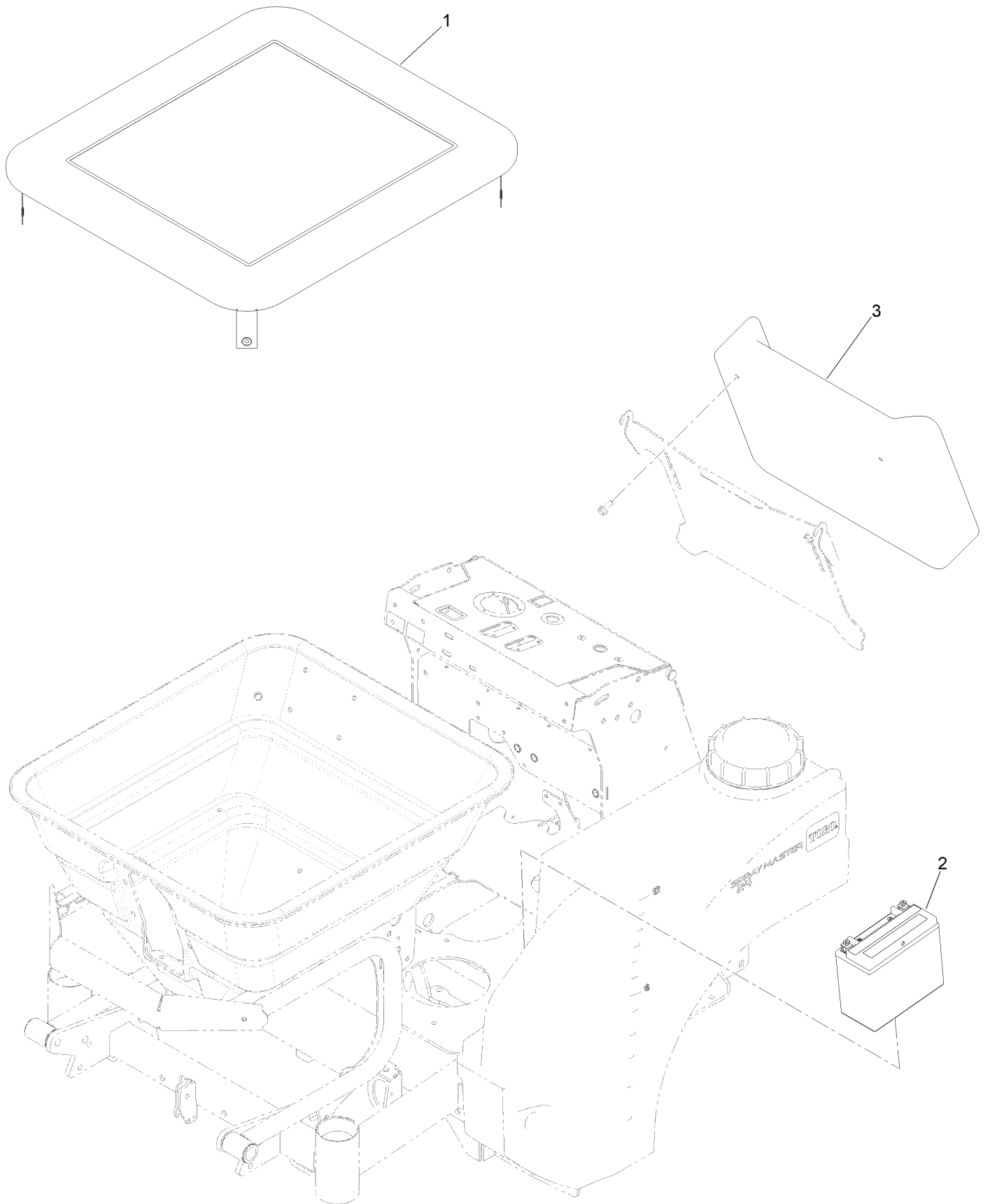



# Hopper Cover, Knee Pad and Battery Assembly (continued)

<i>Ref.</i>	<i>Part Number</i>	<i>Qty.</i>	<i>Description</i>
1	146-0140	1	Cover-Hopper
2	142-7345	1	Battery - Agm, 12V, 310 CCA
3	135-7884	1	Pad-Knee

# Attachments and Accessories

## For 34246 36in Sprayer SprayMaster

<b>Product Name</b>	<b>Model/Part</b>
Nozzle.....	117-5838
Nozzle.....	117-5839
5 PSI Check Valve\N11750-PP-5.....	135-8385
Tip-Spray, 015 .....	142-3306
Tip-Spray, 02 .....	142-3307
Tip-Spray, 025 .....	142-3308
Tip-Spray, 03 .....	142-3309
Tip-Spray, 04 .....	142-3310
Tip-Spray, 05 .....	142-3311
Tip-Spray, 06 .....	142-3312
Wide Application Nozzle Kit.....	142-5488
15FT Hose Reel Kit .....	142-6680
Foam Marker Kit-Jr36 .....	142-6681
Light Kit.....	142-7876
Vibratory Motor .....	142-7877
Pump Kit, 7 Gallon.....	142-7879
20 Gallon Auxiliary Tank Kit, 36in SprayMaster.....	146-0604
7 Gallon Isolated Tank Kit, 36in SprayMaster.....	146-0605
7 Gallon Auxiliary Tank Kit, 36in SprayMaster.....	146-0606
Tip-Spray, XRC11020 .....	146-0633

**Notes:**



**Count on it.**