



Hose Kit

DFS Vac Collection System for 500 Series Z Master

Model No. 107-1633

Form No. 3350-485

Installation Instructions

Use this kit to replace the rigid tubes of your bagging system with a flexible hose.

Loose Parts

Note: Use the chart below to identify parts for assembly.

Description	Qty.	Use
Handled tube	1	Installing the hose kit
Hose clamp	1	Installing the hose kit
Hose	1	Installing the hose kit

Installing the Hose Kit

1. Disengage the PTO and set the parking brake.
2. Stop the engine, remove the key, and wait for all moving parts to stop before leaving the operating position.
3. Remove and store the long middle tube, clamp, and upper tube that came with your bagger (Fig. 1).

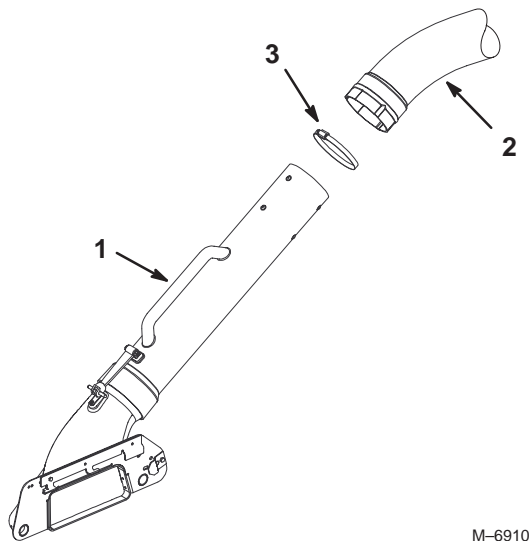
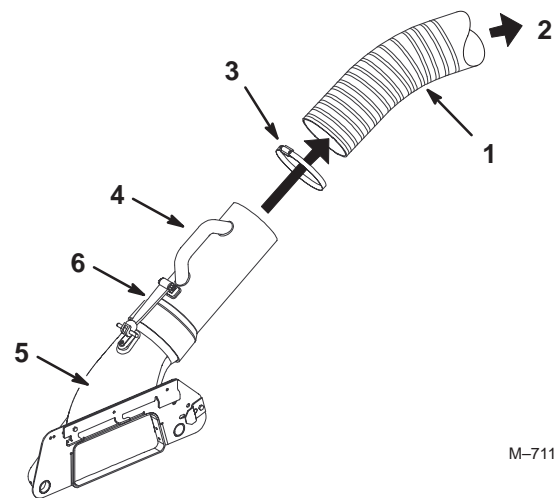

Figure 1

1. Long middle tube
2. Upper tube
3. Clamp

M-6910



M-7117

Figure 2

1. Hose
2. To bagger
3. Clamp
4. Handled tube
5. Boot
6. Latch

4. Fully open the clamp and slide it onto the handled tube (Fig. 2).
5. Slide the hose over the end of the handled tube, ensuring that it is over the ridges on the tube and extends onto the tube far enough so that it touches the handle (Fig. 2).
6. Tighten the clamp around the hose and handled tube connection (Fig. 2).
7. Slide the handled tube onto the boot and latch them together (Fig. 2).
8. Install the end of the hose into the bagger (Fig. 2).

