



Count on it.

Operator's Manual

72in E-Z Vac™ Triple Bagging System

Z Master® G3 Mower

Model No. 78555—Serial No. 412200000 and Up

Model No. 78562—Serial No. 412200000 and Up

Model No. 78563—Serial No. 411300000 and Up

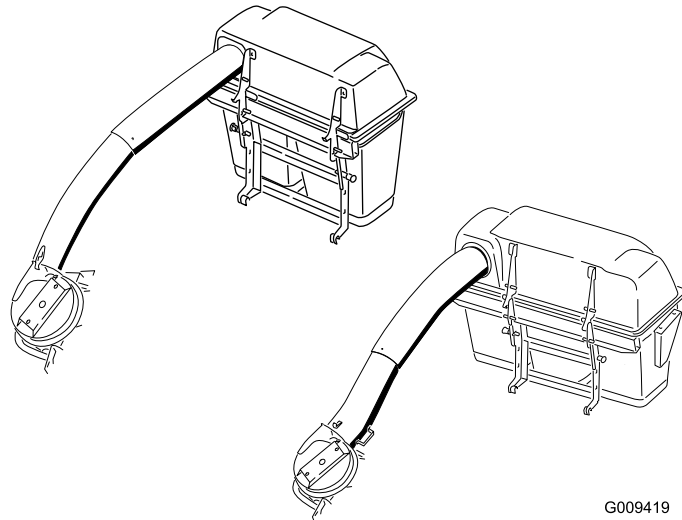

G009419

Note: This bagger requires a Blower and Drive Kit to function. Contact your Authorized Service Dealer to obtain the kit.



This product complies with all relevant European directives. For details, please see the Declaration of Incorporation (DOI) at the back of this publication.

⚠ WARNING

CALIFORNIA
Proposition 65 Warning

Use of this product may cause exposure to chemicals known to the State of California to cause cancer, birth defects, or other reproductive harm.

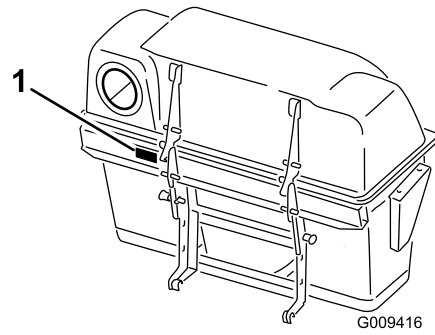

Figure 2

60- and 72-inch bagger serial number

1. Bagger model and serial number location

Introduction

Read this information carefully to learn how to operate and maintain your product properly and to avoid injury and product damage. You are responsible for operating the product properly and safely.

Visit www.Toro.com for product safety and operation training materials, accessory information, help finding a dealer, or to register your product.

Whenever you need service, genuine Toro parts, or additional information, contact an Authorized Service Dealer or Toro Customer Service and have the model and serial numbers of your product ready. [Figure 1](#) and [Figure 2](#) identifies the location of the model and serial numbers on the product. Write the numbers in the space provided.

Model No. _____
Serial No. _____

This manual identifies potential hazards and has safety messages identified by the safety alert symbol ([Figure 3](#)), which signals a hazard that may cause serious injury or death if you do not follow the recommended precautions.



Figure 3

1. Safety alert symbol

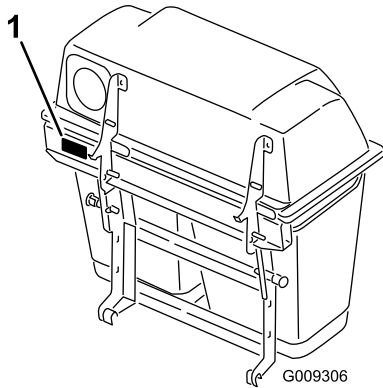

Figure 1

48- and 52-inch bagger serial number

1. Bagger model and serial number location

This manual uses 2 words to highlight information. **Important** calls attention to special mechanical information and **Note** emphasizes general information worthy of special attention.

Contents

Safety	3
Safety and Instructional Decals	4
Setup	5
1 Preparing the Machine	6
2 Installing the Side Bumpers.....	6
3 Installing the Bagger Mounting Brackets.....	7
4 Installing the Hood Assembly and Bags.....	7
5 Installing the Muffler Deflector	10
6 Routing the Blower Belt into the Blower Assembly	10
7 Installing the Blower Assembly.....	11
8 Installing the Discharge Tubes	13

Safety

9 Installing the Belt Cover	17
10 Installing the Weights	18
11 Installing the Bumpers	20
12 Adjusting the Parking Brake	20
13 Checking the Tire Pressure	21
Operation	21
Positioning the Adjustable Baffle	22
Emptying the Grass Bags	22
Clearing Obstructions from the Bagger System	22
Removing the Bagger	23
Using the Grass Deflector	23
Transporting the Machine	23
Operating Tips	23
Maintenance	25
Recommended Maintenance Schedule(s)	25
Cleaning the Hood Screen	25
Cleaning the Bagger and Bags	25
Inspecting the Blower Belt	25
Replacing the Blower Belt for 60- and 72-inch Machines	25
Replacing the Blower Belt for 48- and 52-inch Machines	26
Checking and Adjusting the Blower Latch	27
Greasing the Idler Arm	27
Inspecting the Bagger	28
Inspecting the Mower Blades	28
Installing the Mower Blades	28
Replacing the Grass Deflector	28
Storage	29
Troubleshooting	30

- Become familiar with the safe operation of the equipment, with the operator controls, and safety signs.
- Use extra care with grass catchers or other attachments. These can change the operating characteristics and the stability of the machine.
- Follow the manufacturer's recommendations for adding or removing wheel weights or counterweights to improve stability.
- Do not use a grass catcher on steep slopes. A heavy grass catcher could cause loss of control or overturn the machine.
- Slow down and use extra care on hillsides. Be sure to travel in the recommended direction on hillsides. Turf conditions can affect the stability of the machine. Use extreme caution while operating near drop-offs.
- Keep all movement on slopes slow and gradual. Do not make sudden changes in speed, direction, or turning.
- The grass catcher can obstruct the view to the rear. Use extra care when operating in reverse.
- Use care when loading or unloading the machine into a trailer or truck.
- Never operate with the discharge deflector raised, removed or altered, unless using a grass catcher.
- Keep hands and feet away from moving parts. Do not make adjustments with the engine running.
- Disengage the PTO, move the motion-control levers to the NEUTRAL-LOCK position, engage the parking brake, shut off the engine, remove the key, and wait for all moving parts to stop before leaving the operating position.
- Chock the wheels before emptying the grass catcher or unclogging the chute.
- If you remove the grass catcher, be sure to install any discharge deflector or guard that might have been removed to install the grass catcher. Do not operate the mower without either the entire grass catcher or the grass deflector in place.
- Shut off the engine before removing the grass catcher or unclogging the chute.
- Do not leave grass in the grass catcher for extended periods of time.
- Grass catcher components are subject to wear, damage and deterioration, which could expose you to moving parts or allow objects to be thrown. Frequently check components and replace with the manufacturer's recommended parts, when necessary.

Safety and Instructional Decals



Safety decals and instructions are easily visible to the operator and are located near any area of potential danger. Replace any decal that is damaged or missing.



106-5517

decal106-5517

1. Warning—do not touch the hot surface.

WARNING: Cancer and Reproductive Harm - www.P65Warnings.ca.gov.
For more information, please visit www.ttcocaprop65.com

133-8061

133-8061

decal133-8061

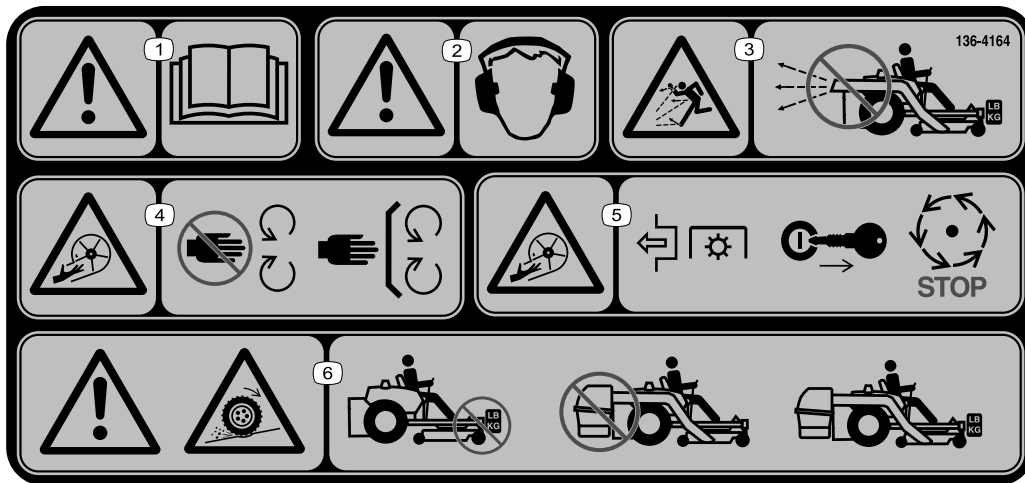

136-4164

decal136-4164

1. Warning—read the *Operator's Manual*.
2. Warning—wear hearing protection.
3. Thrown object hazard—do not run the blower without the entire collection system installed and latched.
4. Cutting/dismemberment hazard of hands, impeller—stay away from moving parts; keep all guards and shields in place.
5. Cutting/dismemberment hazard of hands, impeller—disengage the PTO, remove the key, and wait for all moving parts to stop.
6. Warning; loss of traction and steering or reduced stability hazard—bagger counterbalance weight(s) installed without the bagger may cause loss of traction and steering control; the bagger installed without the bagger counterbalance weight(s) can cause reduced stability; install weight(s) only when the bagger is installed.

Setup

Loose Parts

Use the chart below to verify that all parts have been shipped.

Procedure	Description	Qty.	Use
1	No parts required	–	Prepare the machine.
2	Left bumper Right bumper Carriage bolt (3/8 x 1-1/4 inches) Flange nut (3/8 inch)	1 1 2 6	Install the side bumpers.
3	Upper mounting bracket Lower mounting bracket Carriage bolt (3/8 x 1-1/4 inches) Carriage bolt (1/2 x 2–1/2 inches) Flange nut (3/8 inch) Flange nut (1/2 inch)	1 1 4 2 4 2	Install the bagger mounting brackets.
4	Hood assembly Bag (48-inch and 52-inch decks) Bag (60-inch and 72-inch decks) Pin and hairpin-cotter assembly	1 2 3 2	Install the hood assembly and bags.
5	Muffler deflector Flange nut (3/8 inch) Carriage bolt (3/8 x 1-1/4 inches)	1 2 2	Install the muffler deflector.
6	Blower belt (from Blower and Drive Kit)	1	Route the blower belt into the blower assembly.
7	Blower assembly (from the Blower and Drive Kit) Spring (from the Blower and Drive Kit)	1 1	Install the blower assembly.
8	Upper tube Lower tube Bolt (#10 x 3/4 inches) Locknut (#10) Washer (7/32 inch)	1 1 3 3 3	Install the discharge tubes.
9	Belt cover (from Blower and Drive Kit)	1	Install the belt cover.
10	Caster weight (if needed) Clevis pin Hairpin cotter Lock washer (3/8 inch) Weight-mount bracket Bolt (3/8 x 1-1/2 inches) Flat washer (3/8 inch) Carriage bolt (5/16 x 3/4 inch) Flange nut (5/16 inch) Front weight (48-inch, 52-inch, and 60-inch decks) Front weight [72-inch decks (serial number 406294344 and below)] Front weight [72-inch decks (serial number 406294345 and above)]	2 2 2 6 1 6 6 3 3 3 3 1 2	Install the weights.

Procedure	Description	Qty.	Use
11	Bumper	2	Install the bumpers (for machines with MyRide™ suspension system).
	Spacer	2	
	Locknut (5/16 inch)	2	
12	No parts required	–	Adjust the parking brake.
13	No parts required	–	Check the tire pressure.

Important: Do not use drive or caster Tweels with this attachment. If the machine is equipped with drive or caster Tweels, replace them with factory pneumatic drive tires or factory pneumatic or semi-pneumatic caster tires.

Note: Determine the left and right sides of the machine from the normal operating position.

1

Preparing the Machine

No Parts Required

Procedure

Perform the following procedure to prepare the machine for attaching the blower and finishing kit.

1. Disengage the PTO, move the motion-control levers to the NEUTRAL-LOCKED position, and engage the parking brake.
2. Shut off the engine, remove the key, and wait for all moving parts to stop before leaving the operating position.
3. Repair all bent or damaged areas of machine deck and replace any missing parts.
4. Clean the machine of any debris on the machine deck or rear part of the machine to ease installation.

2

Installing the Side Bumpers

Parts needed for this procedure:

1	Left bumper
1	Right bumper
2	Carriage bolt (3/8 x 1-1/4 inches)
6	Flange nut (3/8 inch)

Procedure

1. Remove the nuts and bolts holding the side bumpers to the machine ([Figure 4](#)).
Note: Discard all nuts and only the 1 bolt removed from each side.
2. Install the new left and right side bumpers with 2 carriage bolts (3/8 x 1-1/4 inches), 4 previously removed carriage bolts, and 6 flange nuts (3/8 inch) as shown in [Figure 4](#).

3

Installing the Bagger Mounting Brackets

Parts needed for this procedure:

1	Upper mounting bracket
1	Lower mounting bracket
4	Carriage bolt (3/8 x 1-1/4 inches)
2	Carriage bolt (1/2 x 2-1/2 inches)
4	Flange nut (3/8 inch)
2	Flange nut (1/2 inch)

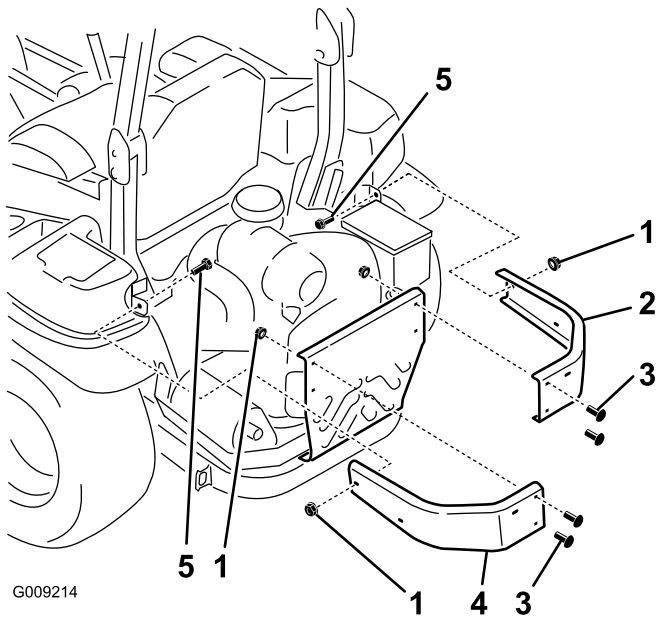

Figure 4

1. Flange nut (3/8 inch)
2. Right bumper
3. Use existing bolts
4. Left bumper
5. Bolt (3/8 x 1-1/4 inches)

Procedure

1. Install the lower mounting bracket to the machine frame with 4 carriage bolts (3/8 x 1-1/4 inches) and 4 flange nuts (3/8 inch) as shown in [Figure 5](#).
2. Install the upper mounting bracket to the left and right side bumpers with 2 carriage bolts (1/2 x 2-1/2 inches) and 2 flange nuts (1/2 inch) as shown in [Figure 5](#).

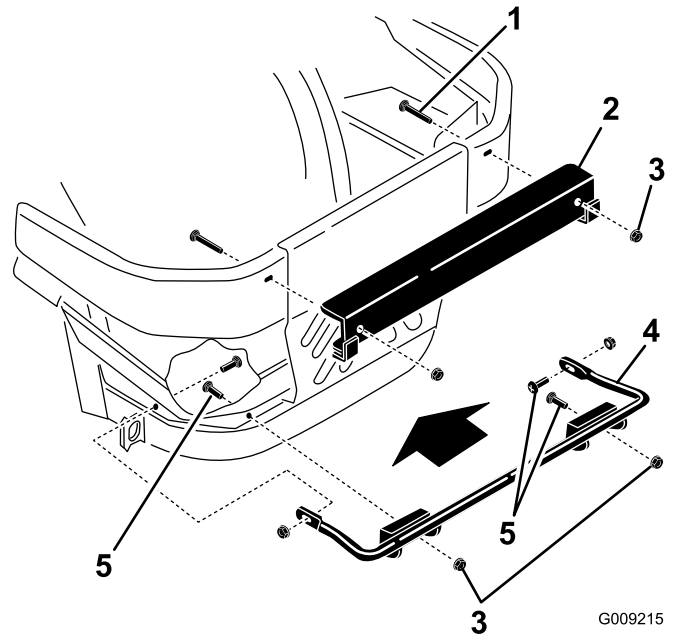

Figure 5

1. Carriage bolt (1/2 x 2-1/2 inches)
2. Upper mounting bracket
3. Flange nut (1/2 inch)
4. Lower mounting bracket
5. Carriage bolt (3/8 x 1-1/4 inches)
6. Flange nut (3/8 inch)

4

Installing the Hood Assembly and Bags

Parts needed for this procedure:

1	Hood assembly
2	Bag (48-inch and 52-inch decks)
3	Bag (60-inch and 72-inch decks)
2	Pin and hairpin-cotter assembly

Procedure

1. Position the hood assembly on its back.
2. Slide hooks onto the lower mounting bracket (Figure 6).
3. Rotate the hood assembly up on the lower bagger mounting bracket (Figure 6).
4. Align the hole in the bagger with the upper mounting bracket (Figure 6).
5. Install the pin and secure it with the hairpin cotter on both sides (Figure 6).

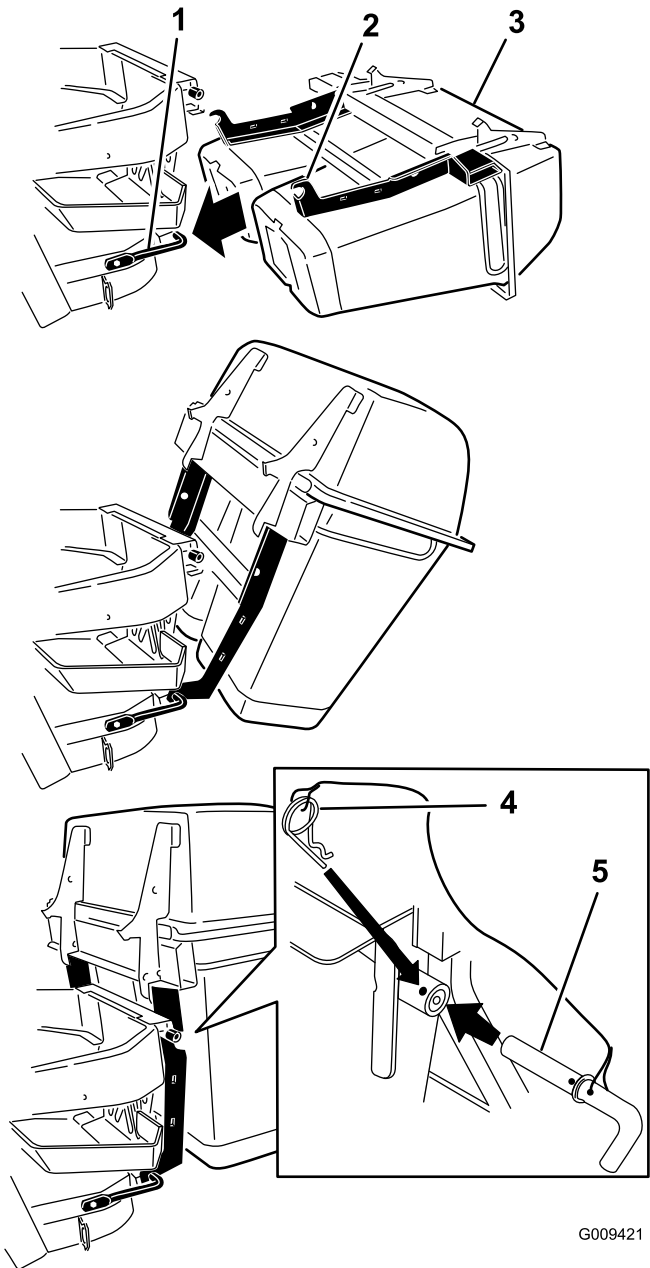

Figure 6

1. Lower mounting bracket
2. Hook
3. Hood assembly
4. Hairpin cotter connected to lanyard
5. Pin connected to lanyard

- Install the bag tab into the notch in the hood assembly (Figure 7 or Figure 8).

Note: Do this for all the bags.

Note: The bags will rest on the bagger frame.

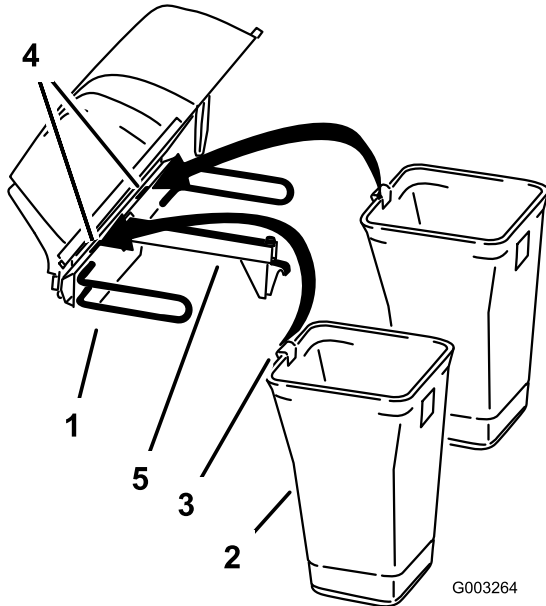

Figure 7

Twin bagger shown

- | | |
|------------------|-----------------|
| 1. Hood assembly | 4. Notch |
| 2. Bag | 5. Bagger frame |
| 3. Bag tab | |

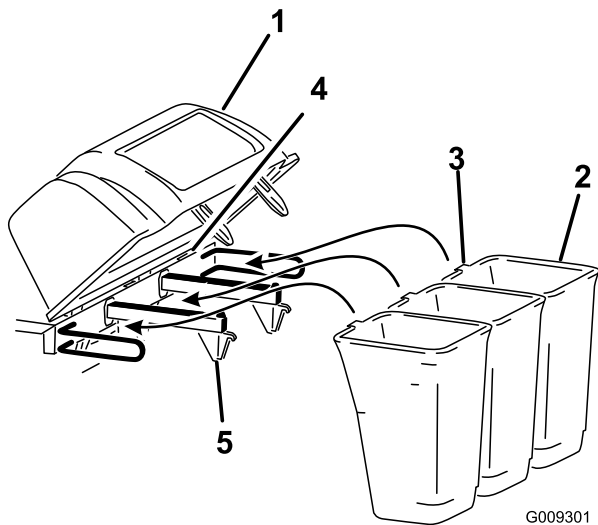

Figure 8

Triple bagger shown

- | | |
|------------------|-----------------|
| 1. Hood assembly | 4. Notch |
| 2. Bag | 5. Bagger frame |
| 3. Bag tab | |

- Lower the bagger hood over the bags (Figure 9 or Figure 10).

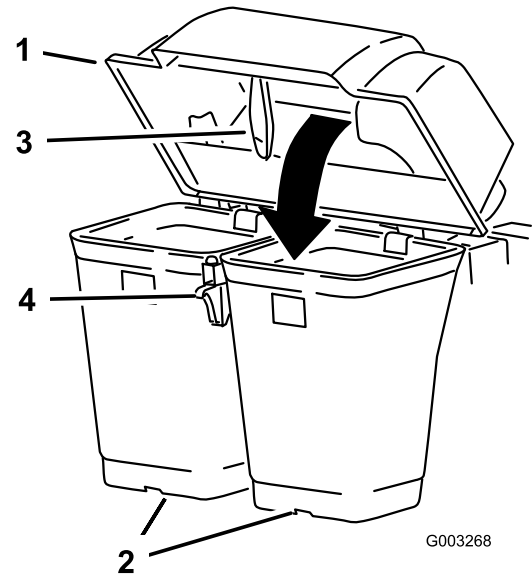

Figure 9

Twin bagger shown

- | | |
|---------|-----------------|
| 1. Hood | 3. Bagger latch |
| 2. Bag | 4. Latch hook |

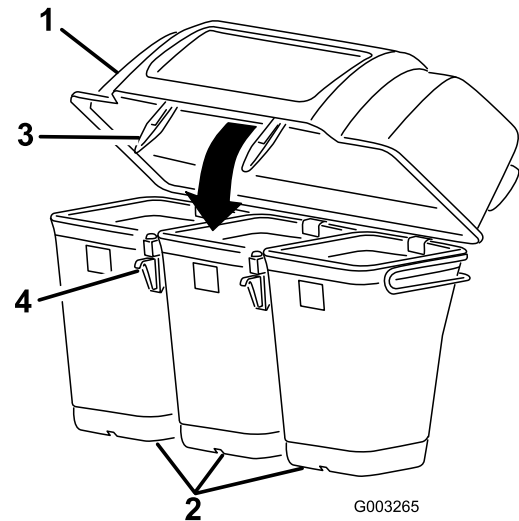
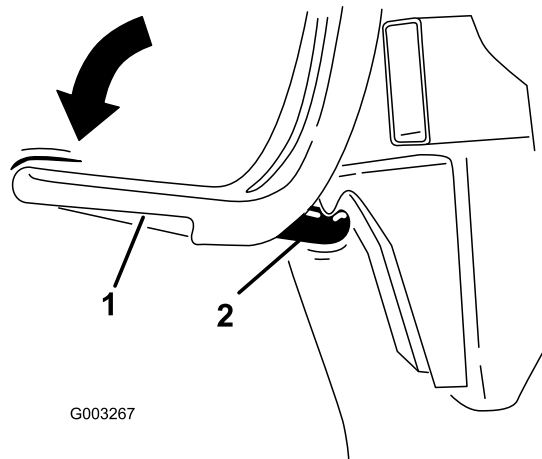

Figure 10

Triple bagger shown

- | | |
|---------|-----------------|
| 1. Hood | 3. Bagger latch |
| 2. Bag | 4. Latch hook |

- Position the bagger latch under the latch hook (Figure 11).
- Push down on bagger latch until it locks into place (Figure 11).



G003267

Figure 11

1. Bagger latch
2. Latch hook

g003267

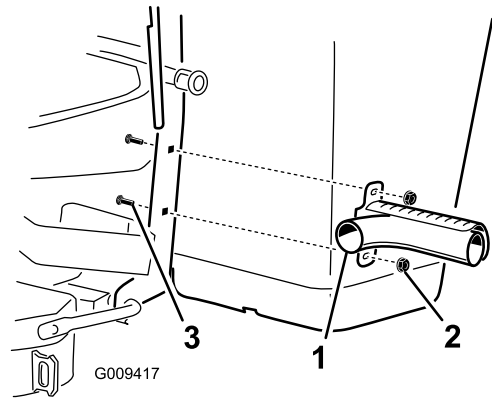

G009417

Figure 12

g009417

1. Muffler deflector
2. Flange nut (3/8 inch)
3. Carriage bolt (3/8 x 1-1/4 inches)

5

Installing the Muffler Deflector

Parts needed for this procedure:

1	Muffler deflector
2	Flange nut (3/8 inch)
2	Carriage bolt (3/8 x 1-1/4 inches)

Procedure

Install the muffler deflector to the side of the bagger frame (Figure 12).

Note: Ensure the muffler deflector is positioned over the tail pipe of the muffler.

6

Routing the Blower Belt into the Blower Assembly

Parts needed for this procedure:

1	Blower belt (from Blower and Drive Kit)
---	---

Procedure

1. For 60- and 72-inch machine decks, install the belt around the blower pulley (Figure 13).

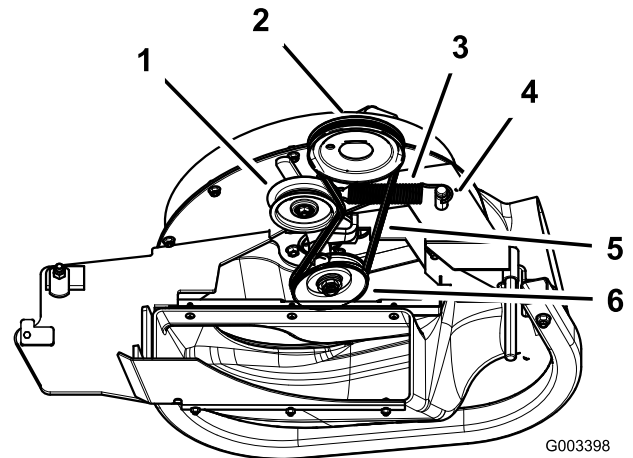

G003398

g003398

Figure 13

Blower for 60- and 72-inch machines

1. Idler pulley
2. Machine deck pulley
3. Spring
4. Spring peg
5. Belt
6. Blower pulley

2. For 48- and 52-inch machines, loosen the belt-guide bolt (Figure 14).
3. Install the belt around the blower pulley and fixed-idler pulley (Figure 14).
4. Tighten the belt-guide bolt.

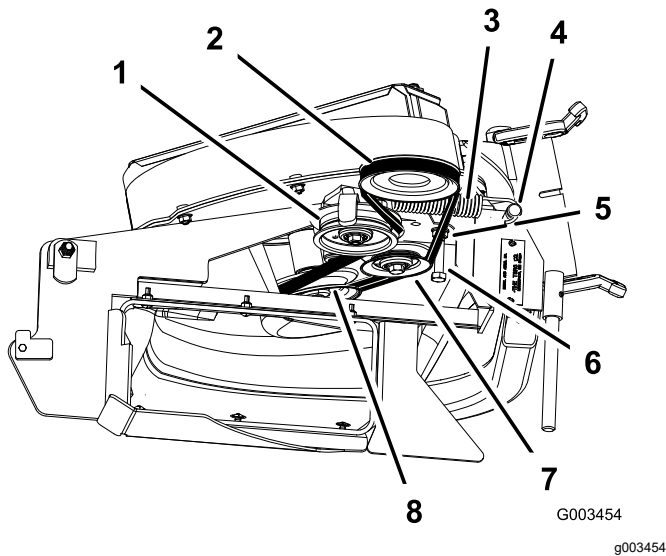

Figure 14

- | | |
|------------------------|-----------------------|
| 1. Idler pulley | 5. Belt |
| 2. Machine deck pulley | 6. Belt-guide bolt |
| 3. Spring | 7. Fixed-idler pulley |
| 4. Spring peg | 8. Blower pulley |

7

Installing the Blower Assembly

Parts needed for this procedure:

1	Blower assembly (from the Blower and Drive Kit)
1	Spring (from the Blower and Drive Kit)

Procedure

⚠ WARNING

An uncovered discharge opening could allow the lawn mower to throw objects at you or bystanders, resulting in serious injury. Also, contact with the blade could occur.

- Never operate the lawn mower unless you install a cover plate, a mulch plate, or a grass chute and catcher.
- Make sure that the grass deflector is installed when the grass chute and catcher are removed.

1. Remove the side discharge chute from the mower deck (Figure 15).

Note: Save all the hardware and the side discharge chute. Install the side discharge chute when the bagger and blower are removed.

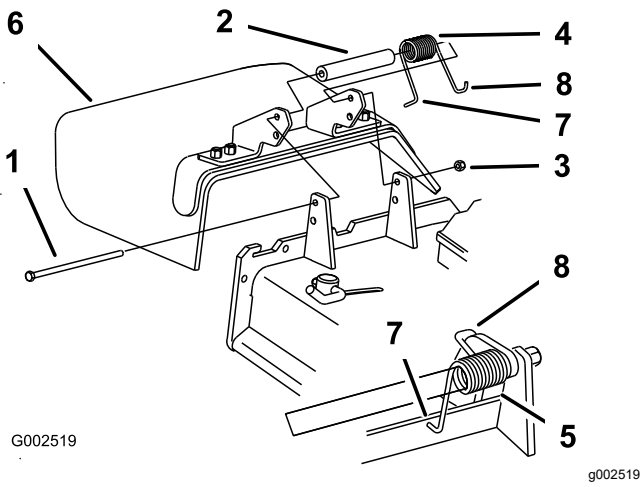

Figure 15

- | | |
|------------|--|
| 1. Bolt | 5. Spring installed |
| 2. Spacer | 6. Grass deflector |
| 3. Locknut | 7. L end of spring (place behind the deck edge before installing the bolt) |
| 4. Spring | 8. J-hook end of spring |

- Slide the blower-assembly peg into the pivot hole (Figure 16 or Figure 17).

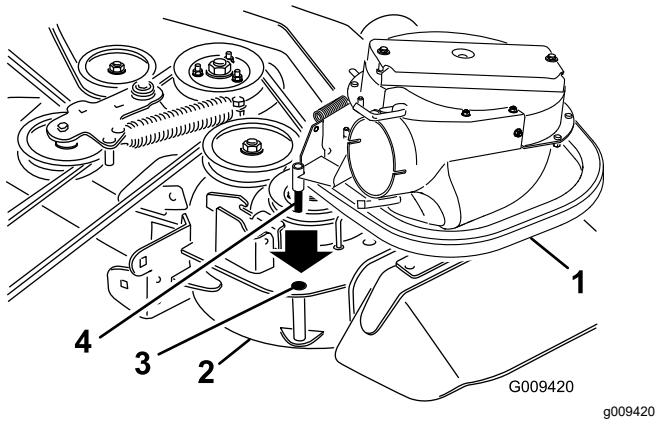

Figure 16

48- and 52-inch mower deck shown

- | | |
|--------------------|------------------------|
| 1. Blower assembly | 3. Pivot hole |
| 2. Mower deck | 4. Blower-assembly peg |

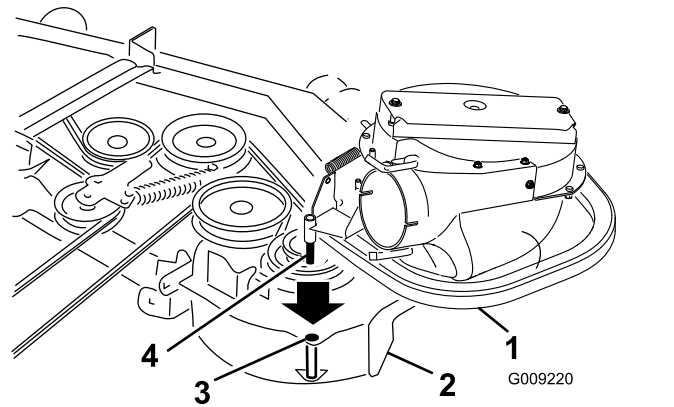

Figure 17

60- and 72-inch mower deck shown

- | | |
|--------------------|------------------------|
| 1. Blower assembly | 3. Pivot hole |
| 2. Mower deck | 4. Blower-assembly peg |

- Close the blower assembly to see if the latches are adjusted correctly.

Note: Loosen or tighten the bolt so the latches firmly hold the blower assembly against the mower deck, but can be released by hand (Figure 18).

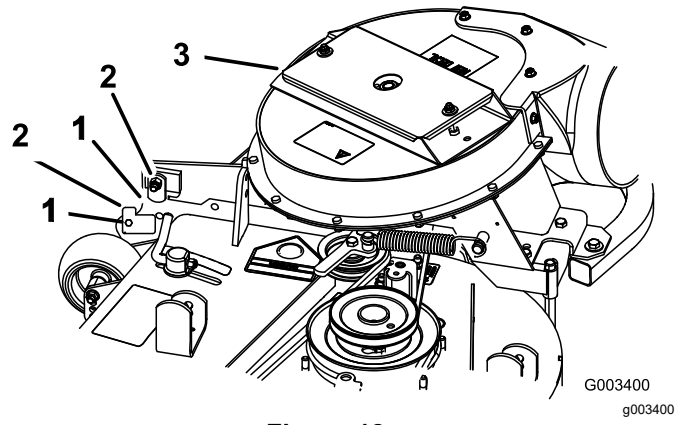

Figure 18

- | | |
|----------|--------------------|
| 1. Latch | 3. Blower assembly |
| 2. Bolt | |

- Install the spring as shown in Figure 19.

Note: Make sure that the hooks are in the correct position.

8

Installing the Discharge Tubes

Parts needed for this procedure:

1	Upper tube
1	Lower tube
3	Bolt (#10 x 3/4 inches)
3	Locknut (#10)
3	Washer (7/32 inch)

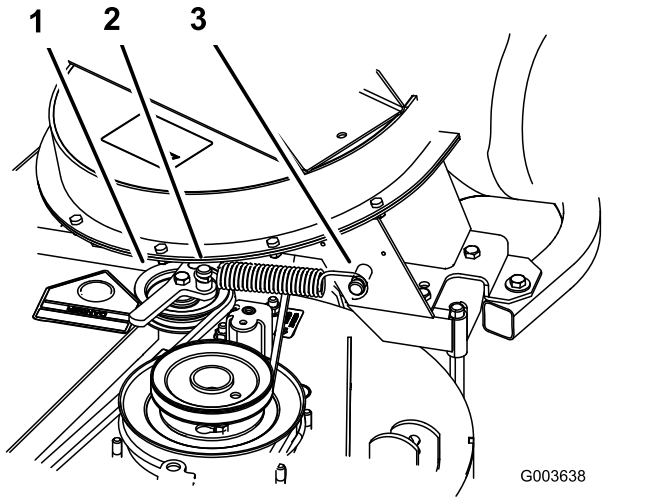

Figure 19

1. Spring-loaded idler pulley
2. Short-hook end
3. Long-hook end

5. Pull the spring-loaded idler pulley back and route the belt around the mower-deck pulley.

Note: Ensure that the belt is routed around the blower pulleys correctly ([Figure 20](#)).

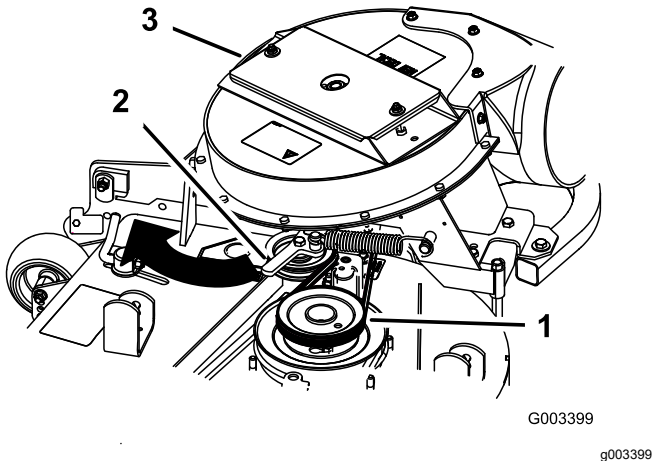

Figure 20

1. Mower-deck pulley
2. Spring-loaded idler pulley
3. Blower

Procedure

Important: Make sure that the mower deck is in the lowest height-of-cut position while installing the discharge tubes.

Note: Remember to replace the grass deflector when the bagger is removed from the machine. Refer to [Replacing the Grass Deflector \(page 28\)](#).

1. Disengage the PTO and engage the parking brake.
2. Shut off the engine, remove the key, and wait for all moving parts to stop before leaving the operating position.
3. Lower the machine deck to the lowest height-of-cut position.
4. Remove the bags for viewing the tube under the hood.
5. Install the upper tube into the bagger opening and pull it back out so that the rubber seal is protruding out ([Figure 21](#) or [Figure 22](#)).

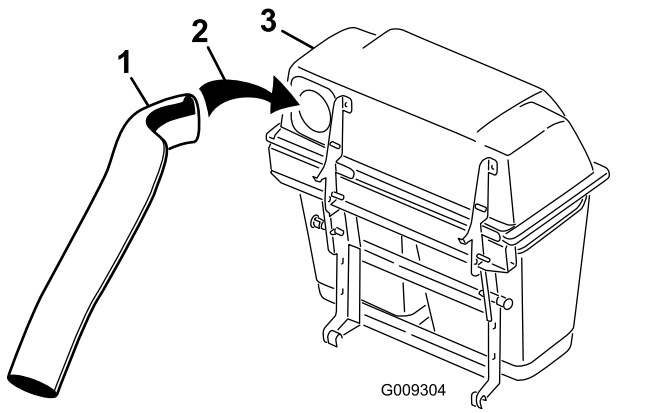

Figure 21

Twin bagger shown

- 1. Upper tube
- 2. Bagger opening
- 3. Bagger hood

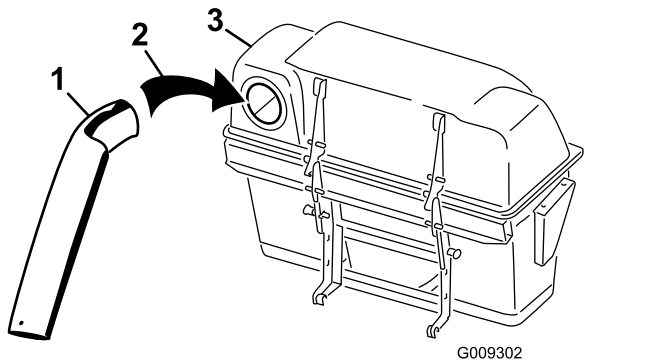

Figure 22

Triple bagger shown

- 1. Upper tube
- 2. Bagger opening
- 3. Bagger hood

6. With the hood in the down position, measure the distance the tube is inside the hood.

Measure from the hood plate to the edge of the tube as shown in Figure 23.

Note: This distance needs to be 19 mm (3/4 inch).

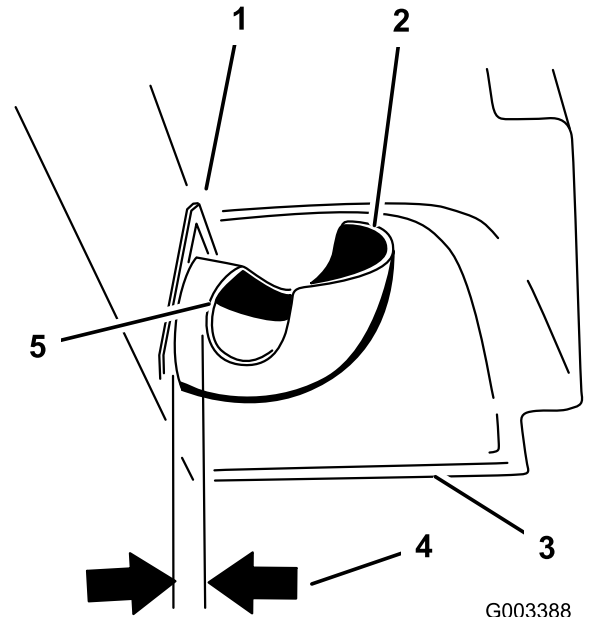

Figure 23

- 1. Hood plate
- 2. Upper tube
- 3. Hood in the down position
- 4. 19 mm (3/4 inch)
- 5. Edge of tube

7. Once the 19 mm (3/4 inch) measurement has been achieved, mark the upper tube on the outside where the rubber seal protrudes out (Figure 24).

Note: This is marked to ensure the correct position for the upper tube when drilling the holes and connecting the upper and lower tubes.

Note: The rubber seal must protrude out from the bagger hood.

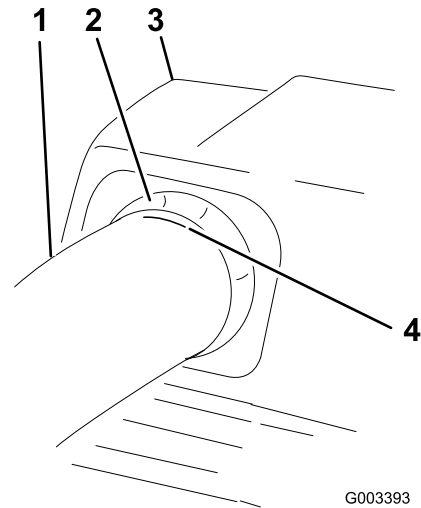

Figure 24

- 1. Upper tube
- 2. Rubber seal protruding out
- 3. Bagger hood
- 4. Mark here against the rubber seal

- Install the lower tube into the upper tube (Figure 25).

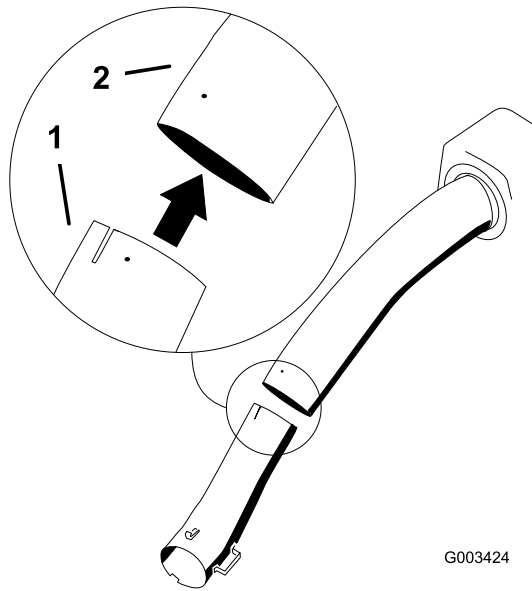

Figure 25

- Lower tube
- Upper tube

- Slide the lower tube onto the boot and latch them together (Figure 26 or Figure 27).

Note: There is a latch on the top and bottom of the blower housing.

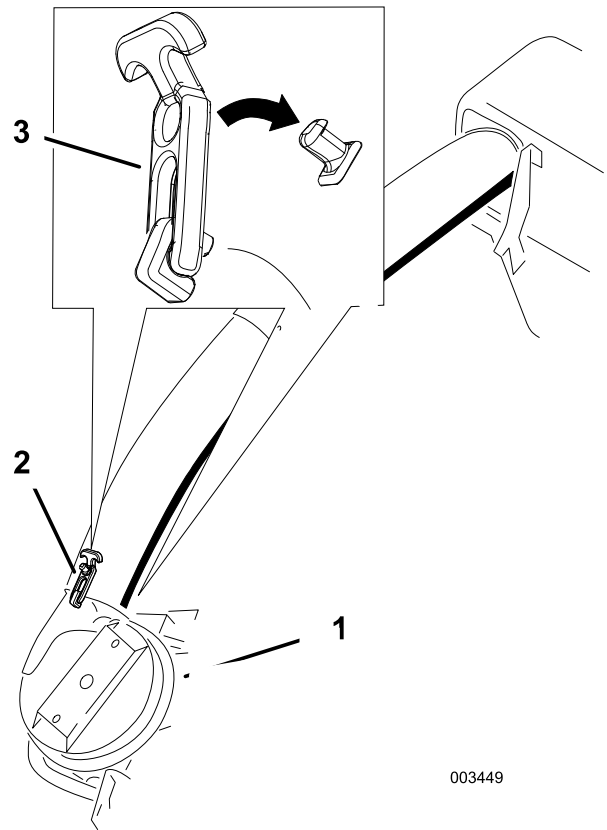
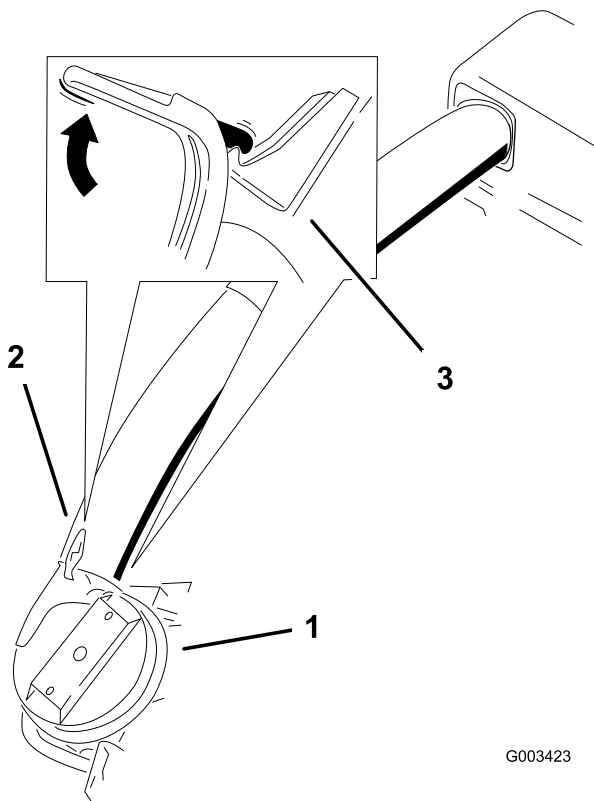

Figure 26
Twin bagger shown

- Blower assembly
- Lower tube
- Latch (twin bagger shown)



G003423

g003423

Figure 27

Triple bagger shown

- | | |
|--------------------|--------------------------------|
| 1. Blower assembly | 3. Latch (triple bagger shown) |
| 2. Lower tube | |

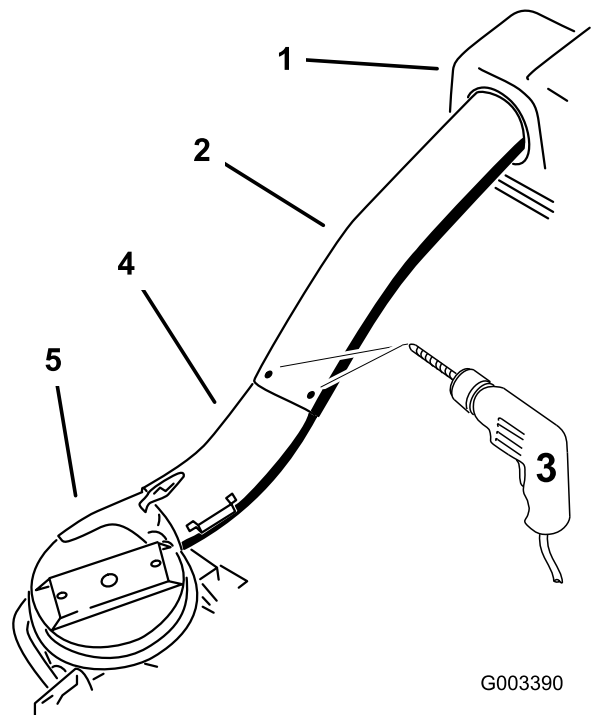

G003390

g003390

Figure 28

- | | |
|---|--------------------|
| 1. Bagger hood | 4. Lower tube |
| 2. Upper tube | 5. Blower assembly |
| 3. Drill 7/32 inch diameter holes here (use upper tube as a template) | |

10. Make sure that the machine deck is in the lowest height-of-cut position.
11. Check to make sure that the mark from [Figure 24](#) is still in place.
12. Using the 3 holes or indentations in the upper tube as a template, drill 3 holes (7/32 inch diameter) where the upper and lower tubes join together ([Figure 28](#)).

13. Remove the lower tube from the blower.
14. Join the upper and lower tubes with 3 bolts (#10 x 3/4 inches), 3 flat washers (7/32 inch), and 3 locknuts (#10) as shown in [Figure 29](#).

9

Installing the Belt Cover

Parts needed for this procedure:

1	Belt cover (from Blower and Drive Kit)
---	--

Procedure

1. Lower the mower deck to the lowest height-of-cut position.
2. Install the new belt cover so that the notches on both sides go over the belt-cover supports and secure the latch (Figure 30 or Figure 31).

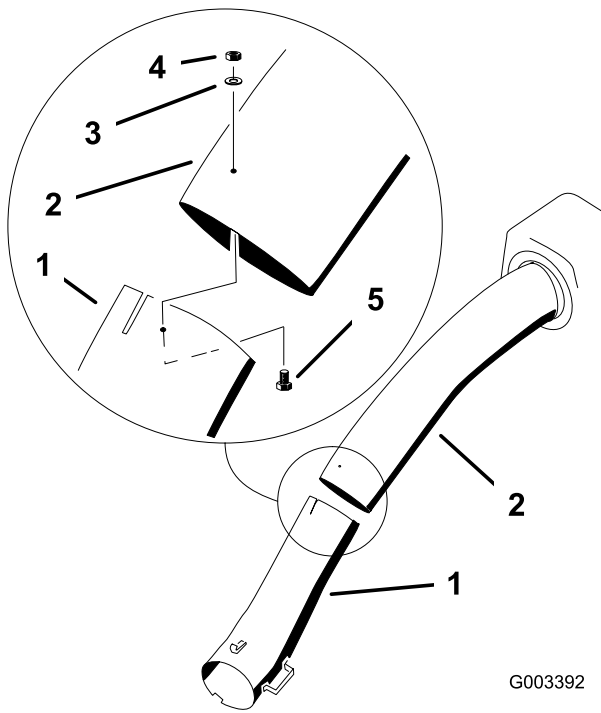

G003392

g003392

Figure 29

1. Lower tube
2. Upper tube
3. Flat washer (7/32 inch)
4. Locknut (#10)
5. Bolt (#10 x 3/4 inches)

-
15. Install the lower tube onto the blower housing and secure it with the latches.
 16. Install the bags onto the bagger.

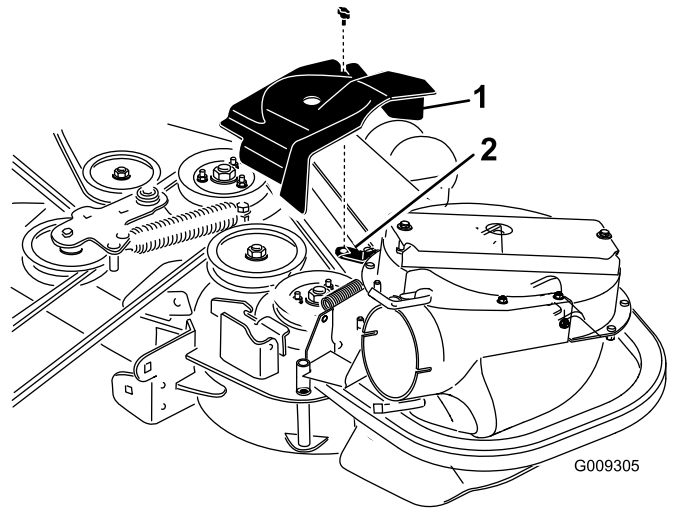

G009305

g009305

Figure 30

48- and 52-inch bagger shown

1. Belt cover
2. Belt-cover support
3. Notch

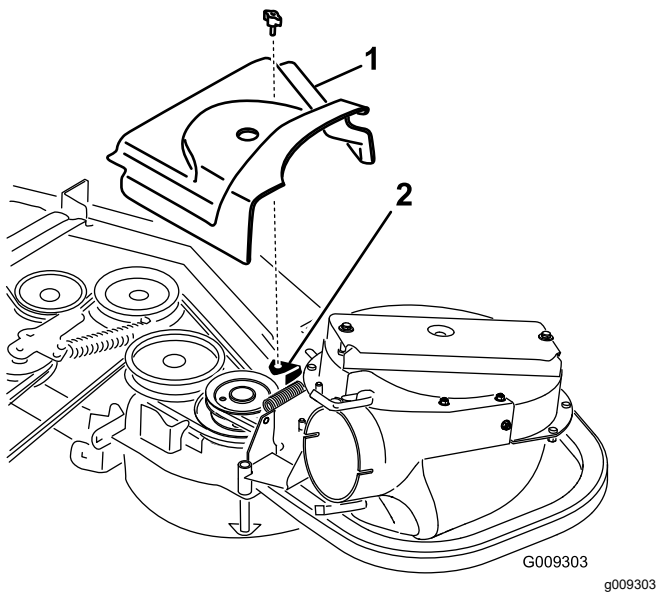

Figure 31
60- and 72-inch bagger shown

- 1. Belt cover
- 2. Belt-cover support
- 3. Notch

⚠ CAUTION

The bagger adds a lot of weight to the rear of the machine and may cause an unstable condition which could result in a loss of control.

The following table shows what weights are used when a bagger is installed.

	Front weights used	Caster weights used
48-inch machine deck with bagger	3	0
52-inch machine deck with bagger	3	0
60-inch machine deck with bagger	3	2
72-inch machine deck with bagger (serial number 406294344 and below)	1	2
72-inch machine deck with bagger (serial number 406294345 and above)	2	2

10

Installing the Weights

Parts needed for this procedure:

2	Caster weight (if needed)
2	Clevis pin
2	Hairpin cotter
6	Lock washer (3/8 inch)
1	Weight-mount bracket
6	Bolt (3/8 x 1-1/2 inches)
6	Flat washer (3/8 inch)
3	Carriage bolt (5/16 x 3/4 inch)
3	Flange nut (5/16 inch)
3	Front weight (48-inch, 52-inch, and 60-inch decks)
1	Front weight [72-inch decks (serial number 406294344 and below)]
2	Front weight [72-inch decks (serial number 406294345 and above)]

Procedure

To comply with ANSI/OPEI B71.4-2012 Standard, add weights to the machine.

1. Install caster weights on the front casters with a clevis pin and a hairpin cotter (Figure 32).
2. Install the nut onto each tap bolt and install the tap bolts into each weight (Figure 32).
3. Tighten the tap bolt so it touches the frame and then tighten the jam nut against the weight.

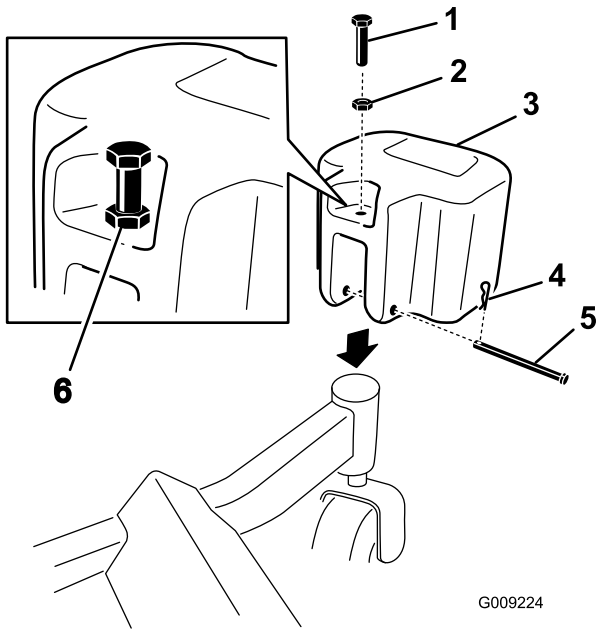

G009224

g009224

Figure 32

- | | |
|----------------------------------|--|
| 1. Tap bolt (3/8 x 1-1/2 inches) | 4. Hairpin cotter |
| 2. Nut (3/8 inch) | 5. Clevis pin |
| 3. Caster weight | 6. Install the tap bolt against the frame and tighten the nut. |

4. Install the weight-mount bracket under the footrest with 2 carriage bolts (5/16 x 3/4 inch) and 2 flange nuts (5/16 inch) as shown in [Figure 33](#).

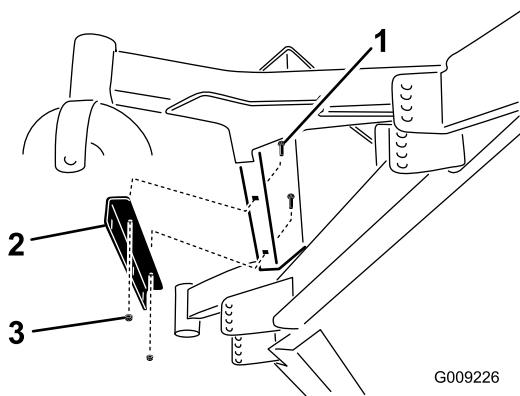

G009226

g009226

Figure 33

- | | |
|------------------------------------|---------------------------|
| 1. Carriage bolt (5/16 x 3/4 inch) | 3. Flange nut (5/16 inch) |
| 2. Weight-mount bracket | |

5. Install the front weights on top of the footrest ([Figure 34](#)).
6. Secure the front weights on top of the footrest and to the weight-mount bracket with 6 bolts (3/8 x 1 inch), 6 lock washers (3/8 inch), 3 flange

nuts (3/8 inch) and 6 flat washers (3/8 inch) as shown in [Figure 34](#).

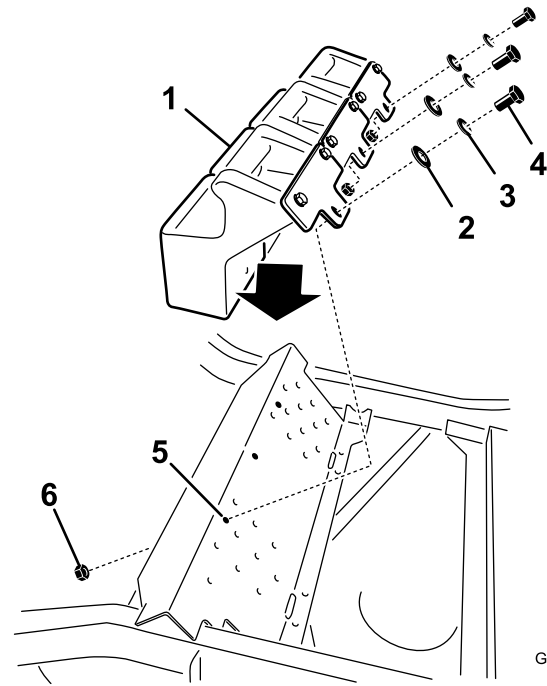

G009227

g009227

Figure 34

- | | |
|---------------------------|--------------------------|
| 1. Front weight | 4. Bolt (3/8 x 1 inch) |
| 2. Flat washer (3/8 inch) | 5. Hole in footrest |
| 3. Lock washer (3/8 inch) | 6. Flange nut (3/8 inch) |

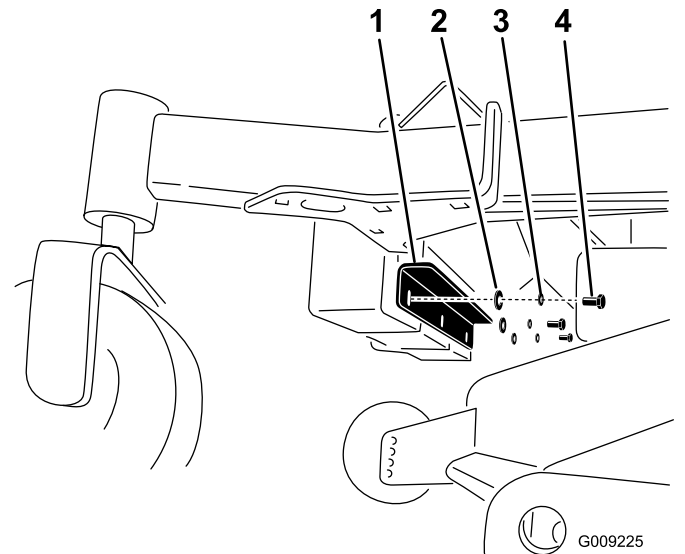

G009225

g009225

Figure 35

- | | |
|---------------------------|---------------------------|
| 1. Weight-mount bracket | 3. Lock washer (3/8 inch) |
| 2. Flat washer (3/8 inch) | 4. Bolt (3/8 x 1 inch) |

11

Installing the Bumpers

Machines with MyRide™ Suspension System

Parts needed for this procedure:

2	Bumper
2	Spacer
2	Locknut (5/16 inch)

Procedure

For 48-inch, 52-inch, 60-inch, and 72-inch decks (serial number 406294345 and above), install the bumpers to the 2 outside holes of the toeboard (Figure 36).

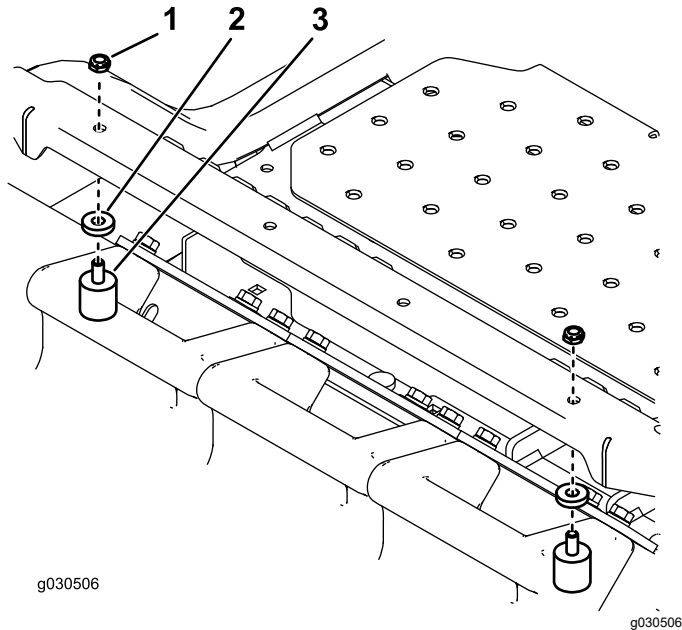

Figure 36

1. Locknut
2. Spacer
3. Bumper

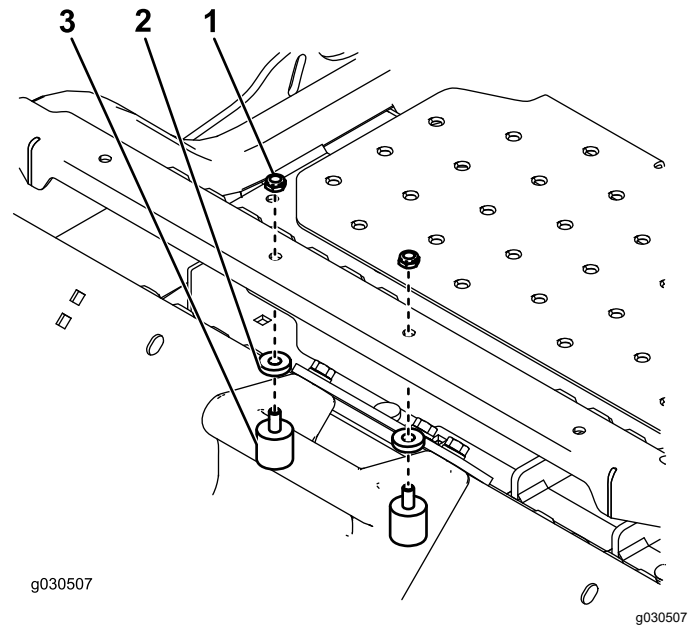

Figure 37

1. Locknut
2. Spacer
3. Bumper

12

Adjusting the Parking Brake

No Parts Required

Procedure

Check to make sure the parking brake is adjusted properly. Refer to your *Operator's Manual* for the correct procedure.

For 72-inch decks (serial number 406294344 and below), install the bumpers to the 2 inside holes of the toeboard (Figure 37).

13

Checking the Tire Pressure

No Parts Required

Procedure

Note: Increase the tire pressure due to the additional weight.

Check and increase the air pressure in the front caster wheels and rear tires (Figure 38).

Air pressure in the rear tires: 138 kPa (20 psi)

Air pressure in the front caster wheels: 172 kPa (25 psi)

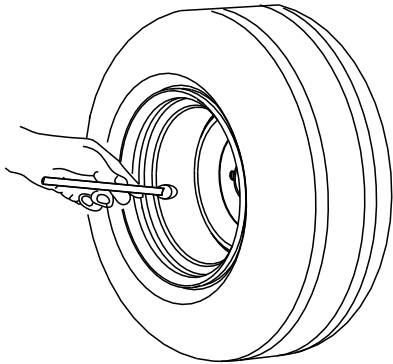

G001055

Figure 38

g001055

Operation

Note: Determine the left and right sides of the machine from the normal operating position.

Important: Engage the parking brake when leaving the machine unattended, even if just for a few minutes.

⚠ WARNING

To avoid personal injury, follow these procedures:

- Become familiar with all operating and safety instructions in the *Operator's Manual* for your machine before using this attachment.
- Never remove the bagger or bagger tubes while the engine is running.
- Always shut off the engine and wait for all moving parts to stop before clearing an obstruction from the bagging system.
- Never do maintenance or repairs while the engine is running.
- Engage the parking brake.

⚠ WARNING

Without the grass deflector, bagger tubes, or complete bagger assembly mounted in place, you and others are exposed to blade contact and thrown debris. Contact with the rotating mower blade(s) and thrown debris will cause injury or death.

- Always install the grass deflector when removing the bagger and changing to side discharge mode.
- If the grass deflector is ever damaged, replace it immediately. The grass deflector routes material down toward the turf.
- Never put your hands or feet under the mower deck.
- Never try to clear the discharge area or mower blades unless you move the power take-off (PTO) to off and rotate the ignition key to off. Also remove the key and pull the wire off the spark plug(s).
- Shut off the engine before unclogging the discharge chute.

⚠ CAUTION

Children or bystanders may be injured if they move or attempt to operate the machine while it is unattended.

Always remove the ignition key and engage the parking brake when leaving the machine unattended, even if just for a few minutes.

Positioning the Adjustable Baffle

Adjust the baffle to position B (middle position) for bagging. Refer to the *Operator Manual* for the machine.

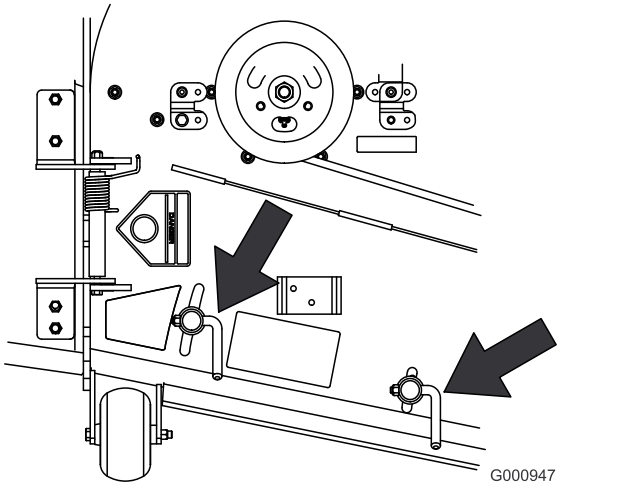

Figure 39

Emptying the Grass Bags

Grass bags are heavy when full. Be careful when lifting or handling a grass bag that is full.

1. Park the machine on a level surface, disengage the PTO, and engage the parking brake.
2. Unlatch the bagger latch.
3. Open the bagger hood.
4. Compress the debris into the bags. With both hands, lift up on the bag and unhook it from the bagger bracket.
5. Grab the handle on the bottom of the bag and tip it over to empty the bag (Figure 40).

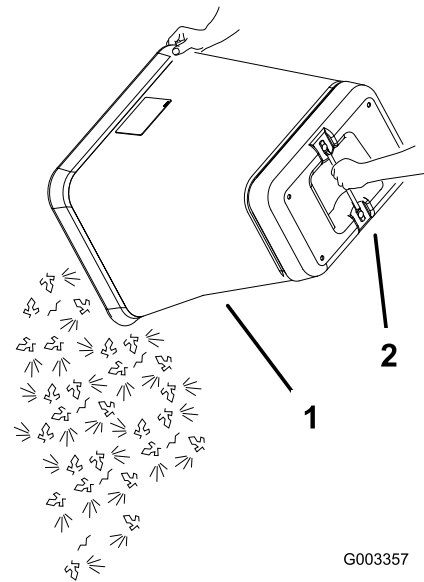

Figure 40

1. Bag
2. Bottom handle

6. Repeat for the other bag.
7. Install the bag tab into the notch in the bagger support frame.
Note: Do this for both bags.
8. Lower the bagger hood over the bags.
9. Latch the bagger hood.

Clearing Obstructions from the Bagger System

⚠ WARNING

When the bagger is in operation, the blower can be rotating and cut off or injure hands.

- Before adjusting, cleaning, repairing and inspecting the blower, and before unclogging the chute, shut off the engine and wait for all moving parts to stop. Remove the key.
 - Use a stick, not your hands, to remove an obstruction from the blower and tube.
 - Keep face, hands, feet, and any other part of your body or clothing away from concealed, moving, or rotating parts.
1. Disengage the PTO and engage the parking brake.
 2. Shut off the engine, remove the key, and wait for all moving parts to stop before leaving the operating position.
 3. Empty the bags.

4. Unlatch the lower tube.
5. Remove the tubes from the bagger.
6. Use a stick or similar object, not your hands, to remove and clear the obstruction from the tube assembly.

Note: In most cases, the debris can be shaken out of the tubes.

7. If the blower assembly is plugged, unlatch the bagger blower assembly, remove the belt, and swing it open.
8. Use a stick or similar object, not your hands, to remove and clear the obstruction from the blower assembly.
9. After you remove the obstruction, install the complete bagger system and resume operation.

Removing the Bagger

⚠ WARNING

Components around engine will be hot if the machine has been running. Touching hot components can cause burns.

- Do not touch engine components when hot.
 - Allow engine to cool before removing the bagger.
1. Park the machine on a level surface, disengage the PTO, and engage the parking brake.
 2. Shut off the engine, remove the key, and wait for all moving parts to stop before leaving the operating position.
 3. Unlatch the lower tube from the blower and remove the tube from the blower assembly.
 4. Remove the tube from the bagger hood.
 5. Lower the mower deck to the lowest height-of-cut position.
 6. Unlatch the belt cover over the mower-pulley assembly.
 7. Remove the bagger belt from the mower-pulley assembly.
 8. Open the blower assembly.
 9. Remove the blower assembly from the pivot hole.
 10. If you are changing to side discharge mode, ensure that the grass deflector is installed and can be lowered into working position.
 11. Remove the hood and bag assembly.

Using the Grass Deflector

⚠ DANGER

Without the grass deflector, discharge cover, or complete grass catcher assembly mounted in place, you and others are exposed to blade contact and thrown debris. Contact with rotating mower blade(s) and thrown debris will cause injury or death.

- Always install the grass deflector when removing the bagger and changing to side discharge mode.
- If the grass deflector is ever damaged, replace it immediately. The grass deflector routes material down toward the turf.
- Never put your hands or feet under the mower deck.
- Never try to clear the discharge area or mower blades unless you move the power take-off (PTO) to the OFF position, rotate the ignition key to off and remove the key.
- Never use your hands to clear the discharge area. Use a stick or similar object to clear the discharge area.

Transporting the Machine

Do not leave grass or debris in the bagger while transporting the machine.

⚠ DANGER

Transporting the machine with grass or debris in the bagger can damage the machine.

Do not leave grass or debris in the bagger while transporting the machine.

Operating Tips

Machine Size

Remember that the machine is longer and wider with this attachment installed. By turning too sharply in confined places you may damage the attachment or other property.

Trimming

Always trim with the left side of the mower deck. Do not trim with the right side of the mower deck because you could damage the bagging tubes.

Cutting Height

For optimum bagging performance, set the deck height-of-cut to remove no more than 51 to 76 mm (2 to 3 inches) or 1/3 of the grass height, whichever is less. Cutting off more than this will reduce the capacity of the vacuum system.

Cutting Frequency

Cut the grass often, especially when it grows rapidly. You will have to cut your grass twice if it gets excessively long (refer to [Bagging Long Grass \(page 24\)](#)).

Cutting Technique

For best lawn appearance, be sure to slightly overlap the mower deck into the previously cut area. This helps reduce the load on the engine and reduces the chance of plugging the blower assembly and tubes.

Bagging Speed

The bagging system may plug if you drive too fast and the engine speed gets too slow. On hills it may be necessary to slow the ground speed of the machine. Mow downhill whenever possible.

▲ CAUTION

As the bagger fills, extra weight is added to the back of the machine. If you stop and start suddenly on hills, you may lose steering control or the machine may tip.

- **Do not start or stop suddenly when going uphill or downhill. Avoid uphill starts.**
- **If you do stop the machine when going uphill, disengage the PTO. Then back down the hill using a slow speed.**
- **Do not change speeds or stop on slopes.**

Bagging Long Grass

If the grass is ever allowed to grow longer than normal, or if it contains a high degree of moisture, raise the cutting height higher than usual and cut and bag the grass at this setting. Then cut and bag the grass again using the lower, normal setting.

Excessively long grass is heavy and may not be propelled completely into the bagger. If this happens, the tube and blower may plug. To avoid plugging the bagging system, mow the grass at a high height-of-cut, then lower the mower deck to your normal cutting height and repeat the bagging process.

Bagging Wet Grass

If possible, always try to cut grass when it is dry. Wet grass can cause plugging.

Reducing Plugging

To avoid plugging the bagging system, reduce ground speed and mow the grass at a high height-of-cut, then lower the mower deck to your normal cutting height and repeat the bagging process.

Signs of Plugging

As you are bagging, a small amount of grass clippings normally blow out the front of the mower deck. An excessive amount of clipping blowout indicates that the bagger is full or the tube is plugged.

Bagging Blades

In most mowing conditions, the standard high lift blades will provide the best bagging performance.

The Toro Atomic blade is recommended for bagging leaves in dry conditions. In dry dusty conditions, the medium lift or low lift blades will reduce dust and dirt blowout while providing effective bagging air flow.

Contact an Authorized Service Dealer for the proper blades for different mowing conditions.

Curb Climbing and Loading

Always lift the deck to the highest position when loading the machine on trailers or ascending/descending a curb. Leaving the mower deck in a lower position can cause damage to the mower deck while loading and going over a curb. If a curb is higher than 152 mm (6 inches), cross it at a sharp angle with the deck fully raised. Use extreme caution when loading onto a trailer.

Maintenance

Recommended Maintenance Schedule(s)

Maintenance Service Interval	Maintenance Procedure
After the first 8 hours	<ul style="list-style-type: none">• Inspect the blower belt.• Inspect the bagger.
Before each use or daily	<ul style="list-style-type: none">• Clean the hood screen.• Clean the bagger.
Every 25 hours	<ul style="list-style-type: none">• Inspect the blower belt.
Every 50 hours	<ul style="list-style-type: none">• Grease the idler arm.
Every 100 hours	<ul style="list-style-type: none">• Inspect the bagger.

Cleaning the Hood Screen

Service Interval: Before each use or daily

The screens need to be cleaned before each use. In wet grass they will need to be cleaned more often.

1. Disengage the power take-off (PTO) and engage the parking brake.
2. Shut off the engine, remove the key, and wait for all moving parts to stop before leaving the operating position.
3. Open the bagger hood.
4. Clean the debris from the screen.
5. Close the bagger hood.

Cleaning the Bagger and Bags

Service Interval: Before each use or daily

The bagger needs to be cleaned daily.

1. Wash the inside and outside of the bagger hood, bags, tube, and the underside of the mower deck. Use a mild automotive detergent to remove dirt.
2. Make sure that you remove matted grass from all parts.
3. After washing all the parts, let them dry thoroughly.

Note: With all parts installed, start and run the machine for a minute to assist in drying.

Inspecting the Blower Belt

Service Interval: After the first 8 hours

Every 25 hours

Check belts for cracks, frayed edges, burn marks or any other damage. Replace damaged belts.

Replacing the Blower Belt for 60- and 72-inch Machines

1. Disengage the PTO, move the motion-control levers to the NEUTRAL-LOCKED position, and engage the parking brake.
2. Shut off the engine, remove the key, and wait for all moving parts to stop before leaving the operating position.
3. Pull back on the spring-loaded idler pulley to relieve the belt tension ([Figure 41](#)).
4. Remove the existing bagger belt from the mower-deck pulley and then the blower pulleys.
5. Install the new belt around the blower pulleys and the mower-deck pulley ([Figure 41](#)).

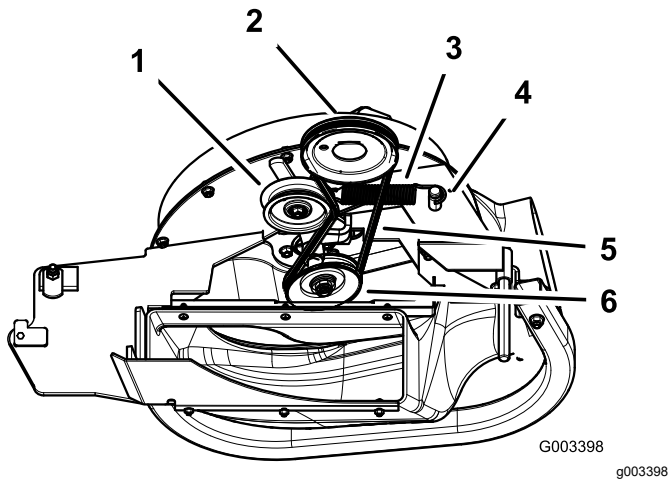

Figure 41

- | | |
|----------------------|------------------|
| 1. Idler pulley | 4. Spring peg |
| 2. Mower-deck pulley | 5. Belt |
| 3. Spring | 6. Blower pulley |

6. Install the spring as shown in [Figure 42](#).

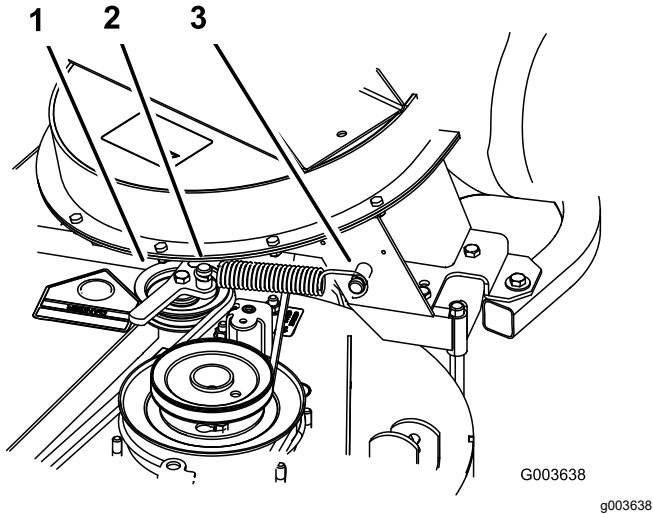

Figure 42

- | | |
|-------------------------------|------------------|
| 1. Spring-loaded idler pulley | 3. Long-hook end |
| 2. Short-hook end | |

7. Pull back on the spring-loaded idler pulley and install the belt onto the spring-loaded idler pulley ([Figure 41](#)).

2. Shut off the engine, remove the key, and wait for all moving parts to stop before leaving the operating position.
3. Loosen the belt-guide bolt ([Figure 43](#)).
4. Remove the existing blower belt.
5. Install the new belt around the blower pulley ([Figure 43](#)).
6. Install the belt between the fixed-idler pulley and the belt-guide bolt.
7. Tighten the belt-guide bolt ([Figure 43](#)).

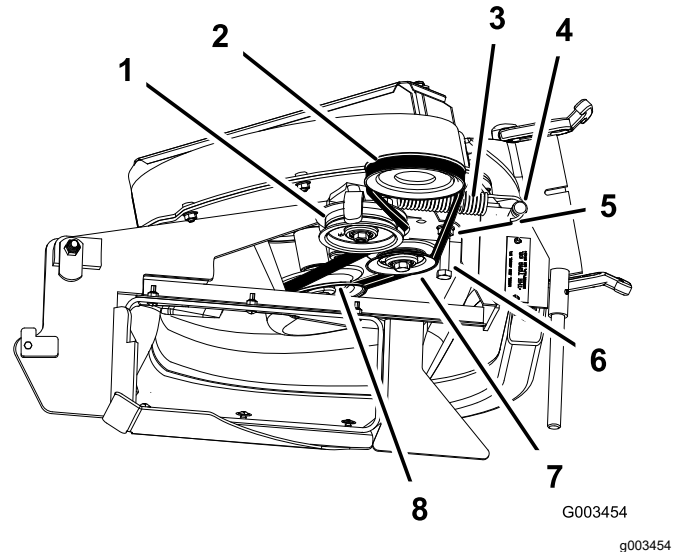

Figure 43

- | | |
|----------------------|-----------------------|
| 1. Idler pulley | 5. Belt |
| 2. Mower-deck pulley | 6. Belt-guide bolt |
| 3. Spring | 7. Fixed-idler pulley |
| 4. Spring peg | 8. Blower pulley |

8. Install the spring as shown in [Figure 44](#).

Replacing the Blower Belt for 48- and 52-inch Machines

1. Disengage the PTO, move the motion-control levers to the NEUTRAL-LOCKED position, and engage the parking brake.

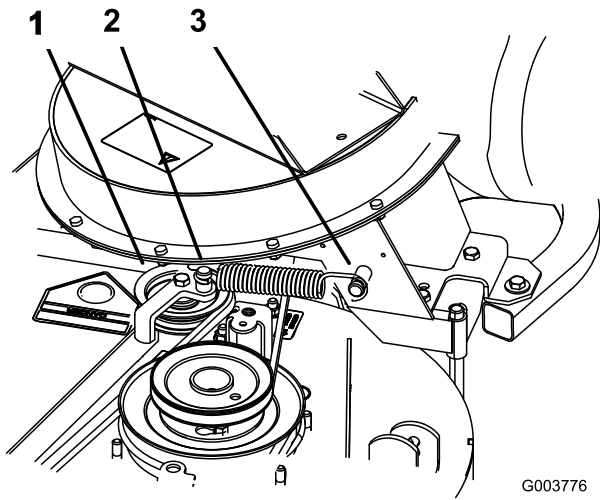

Figure 44

G003776
g003776

1. Spring-loaded idler pulley
2. Short-hook end
3. Long-hook end

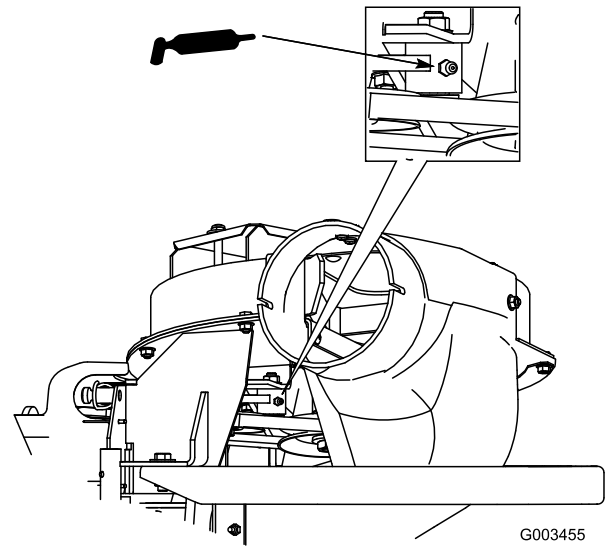

Figure 46

G003455
g003455

9. Install the belt onto the spring-loaded idler pulley (Figure 43).

Checking and Adjusting the Blower Latch

Close the blower assembly to see if the latches are adjusted correctly. Loosen or tighten the bolts so that the latches firmly hold the blower assembly against the mower deck but can be released by hand.

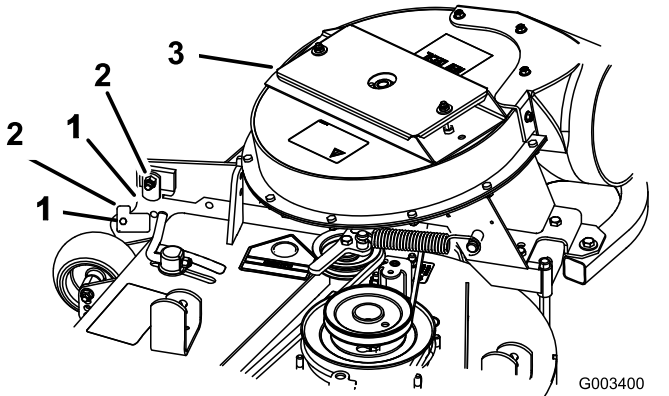

Figure 45

G003400
g003400

1. Latch
2. Bolt
3. Blower assembly

Greasing the Idler Arm

Service Interval: Every 50 hours

Grease the bagger belt idler arm (Figure 46) every 50 hours.

Inspecting the Bagger

Service Interval: Every 100 hours

After the first 8 hours

1. Disengage the PTO, move the motion-control levers to the NEUTRAL-LOCKED position, and engage the parking brake.
2. Shut off the engine, remove the key, and wait for all moving parts to stop before leaving the operating position.
3. Check the upper tube, lower tube, bagger hood, and the blower assembly. Replace these parts if they are cracked or broken.
4. Check the bags, bagger frame, and screen. Replace any parts that are cracked or broken.
5. Tighten all nuts, bolts and screws.

Inspecting the Mower Blades

1. Inspect the mower blades regularly and whenever a blade strikes a foreign object.
2. If blades are badly worn or damaged, install new blades. Refer to your machine *Operator's Manual* for complete blade maintenance.

Installing the Mower Blades

In most mowing conditions, the standard high lift blades will provide the best bagging performance.

The Toro Atomic blade is recommended for bagging leaves in dry conditions. In dry dusty conditions, the medium lift or low lift blades will reduce dust and dirt blowout while providing effective bagging air flow.

Contact an Authorized Service Dealer for the proper blades for different mowing conditions.

Refer to the machines *Operator's Manual* for more information on installing blades.

Replacing the Grass Deflector

⚠ WARNING

An uncovered discharge opening could allow the lawn mower to throw objects at you or bystanders, resulting in serious injury. Also, contact with the blade could occur.

- **Never operate the lawn mower unless you install a cover plate, a mulch plate, or a grass chute and catcher.**
- **Make sure that the grass deflector is in the down position.**

1. Remove the locknut, bolt, spring and spacer holding the deflector to the pivot brackets (Figure 47).
2. Remove the damaged or worn grass deflector.
3. Place the spacer and spring onto the grass deflector. Place the L-end of the spring behind the deck edge.

Note: Make sure that the L-end of the spring is installed behind the deck edge before installing the bolt as shown in Figure 47

4. Install the bolt and nut.
5. Place the J-hook end of the spring around the grass deflector (Figure 47).

Important: The grass deflector must be able to lower down into position. Lift the deflector up to test that it lowers into the full down position.

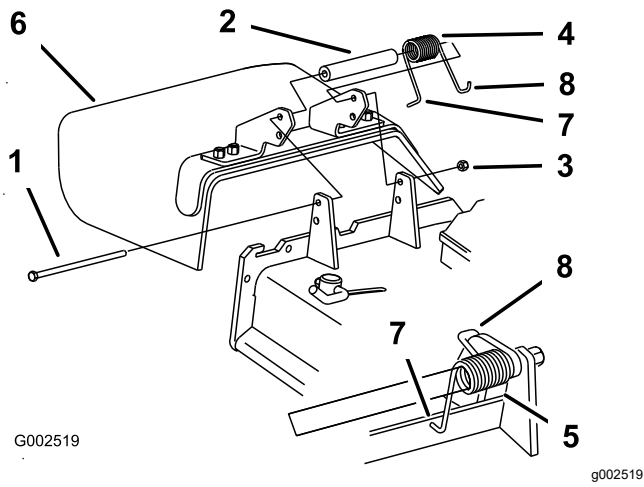

Figure 47

- | | |
|------------|---|
| 1. Bolt | 5. Spring (installed) |
| 2. Spacer | 6. Grass deflector |
| 3. Locknut | 7. L-end of spring, place behind deck edge before installing bolt |
| 4. Spring | 8. J-hook end of spring |

Storage

1. Clean the bagger attachment. Refer to [Cleaning the Bagger and Bags \(page 25\)](#).
2. Inspect the bagger attachment for damage. Refer to [Inspecting the Bagger \(page 28\)](#).
3. Make sure that the bags are empty and thoroughly dry.
4. Check the belt for wear or cracks.
5. Store the machine in a clean, dry place, out of direct sunlight. If you must store the machine outside, cover it with a weatherproof cover. This protects the plastic parts and extends the life of the machine.

Troubleshooting

Problem	Possible Cause	Corrective Action
There is abnormal vibration.	<ol style="list-style-type: none"> 1. The cutting blade(s) is/are bent or unbalanced. 2. The blade mounting bolt is loose. 3. The blower pulley or pulley assembly is loose. 4. The bagger belt is worn. 5. The blower fan blade(s) is/are bent or unbalanced. 	<ol style="list-style-type: none"> 1. Install new cutting blade(s). 2. Tighten the blade mounting bolt. 3. Tighten the appropriate pulley. 4. Replace the belt. 5. Contact an Authorized Service Dealer.
There is reduced bagging performance.	<ol style="list-style-type: none"> 1. The engine speed is low. 2. The bagger-hood screen is plugged. 3. Loose bagger belt. 4. The blower or tube is plugged. 5. The bags are full. 	<ol style="list-style-type: none"> 1. Always operate the bagger at full throttle. 2. Remove the debris, leaves or grass clippings from the screen. 3. Replace the bagger belt. 4. Locate and remove the plugged debris. 5. Empty the bags.
The blower and tubes plug too frequently.	<ol style="list-style-type: none"> 1. The bags are too full. 2. The engine speed is low. 3. The grass is too wet. 4. The grass is too long. 5. The screen in the hood is plugged. 6. The ground speed is too fast. 7. The bagger belt is worn. 	<ol style="list-style-type: none"> 1. Dump the bags more frequently. 2. Always operate the bagger at full throttle. 3. Cut the grass when it is dry. 4. Cut no more than 2-3 inches (51-76 mm) or 1/3 of the grass height, which ever is less. 5. Remove the debris, leaves or grass clippings from the screen. 6. Drive slower at full throttle. 7. Replace the belt.
There is debris blowout.	<ol style="list-style-type: none"> 1. The bags are too full. 2. The ground speed is too fast. 3. The mower deck is not leveled. 	<ol style="list-style-type: none"> 1. Dump the bags more frequently. 2. Drive slower at full throttle. 3. See the mower operator's manual for leveling the mower deck.
The blower impeller does not spin freely.	<ol style="list-style-type: none"> 1. The blower is plugged. 2. The impeller is not aligned. 	<ol style="list-style-type: none"> 1. Remove the debris, leaves or grass clippings from the blower impeller. 2. Contact an Authorized Service Dealer.

Notes:

Notes:

Notes:

Declaration of Incorporation

The Toro Company, 8111 Lyndale Ave. South, Bloomington, MN, USA declares that the following unit(s) conform(s) to the directives listed, when installed in accordance with the accompanying instructions onto certain Toro models as indicated on the relevant Declarations of Conformity.

Model No.	Serial No.	Product Description	Invoice Description	General Description	Directive
78555	412200000 and Up	72in E-Z Vac Triple Bagging System, Z Master G3 Mower	E-Z VAC 72IN DFS BAGGER	Bagger	2006/42/EC, 2000/14/EC
78562	412200000 and Up	48in and 52in E-Z Vac Twin Bagging System, Z Master G3 Mower	E-Z VAC 48IN, 52IN SOFT BAGGER	Bagger	2006/42/EC, 2000/14/EC
78563	411300000 and Up	60in E-Z Vac Triple Bagging System, Z Master G3 Mower	E-Z VAC 60" SOFT BAGGER	Bagger	2006/42/EC, 2000/14/EC

Relevant technical documentation has been compiled as required per Part B of Annex VII of 2006/42/EC.

We will undertake to transmit, in response to requests by national authorities, relevant information on this partly completed machinery. The method of transmission shall be electronic transmittal.

This machinery shall not be put into service until incorporated into approved Toro models as indicated on the associated Declaration of Conformity and in accordance with all instructions, whereby it can be declared in conformity with all relevant Directives.

Certified:



John Heckel
Engineering Director
8111 Lyndale Ave. South
Bloomington, MN 55420, USA
October 7, 2022

Authorized Representative:

Marcel Dutrieux
Manager European Product Integrity
Toro Europe NV
Nijverheidsstraat 5
2260 Oevel
Belgium

UK Declaration of Incorporation

The Toro Company, 8111 Lyndale Ave. South, Bloomington, MN, USA declares that the following unit(s) conform(s) to the directives listed, when installed in accordance with the accompanying instructions onto certain Toro models as indicated on the relevant Declarations of Conformity.

Model No.	Serial No.	Product Description	Invoice Description	General Description	Regulation
78555	412200000 and Up	72in E-Z Vac Triple Bagging System, Z Master G3 Mower	E-Z VAC 72IN DFS BAGGER	Bagger	S.I. 2008 No. 1597, S.I. 2001 No. 1701
78562	412200000 and Up	48in and 52in E-Z Vac Twin Bagging System, Z Master G3 Mower	E-Z VAC 48IN, 52IN SOFT BAGGER	Bagger	S.I. 2008 No. 1597, S.I. 2001 No. 1701
78563	411300000 and Up	60in E-Z Vac Triple Bagging System, Z Master G3 Mower	E-Z VAC 60" SOFT BAGGER	Bagger	S.I. 2008 No. 1597, S.I. 2001 No. 1701

Relevant technical documentation has been compiled as required per Schedule 10 of S.I. 2008 No. 1597.

We will undertake to transmit, in response to requests by national authorities, relevant information on this partly completed machinery. The method of transmission shall be electronic transmittal.

This machinery shall not be put into service until incorporated into approved Toro models as indicated on the associated Declaration of Conformity and in accordance with all instructions, whereby it can be declared in conformity with all relevant Directives.

This declaration has been issued under the sole responsibility of the manufacturer.
The object of the declaration is in conformity with relevant UK legislation.

Authorized Representative:

Marcel Dutrieux
Manager European Product Integrity
Toro U.K. Limited
Spellbrook Lane West
Bishop's Stortford
CM23 4BU
United Kingdom



John Heckel
Engineering Director
8111 Lyndale Ave. South
Bloomington, MN 55420, USA
October 7, 2022

California Proposition 65 Warning Information

What is this warning?

You may see a product for sale that has a warning label like the following:



WARNING: Cancer and Reproductive Harm—www.p65Warnings.ca.gov.

What is Prop 65?

Prop 65 applies to any company operating in California, selling products in California, or manufacturing products that may be sold in or brought into California. It mandates that the Governor of California maintain and publish a list of chemicals known to cause cancer, birth defects, and/or other reproductive harm. The list, which is updated annually, includes hundreds of chemicals found in many everyday items. The purpose of Prop 65 is to inform the public about exposure to these chemicals.

Prop 65 does not ban the sale of products containing these chemicals but instead requires warnings on any product, product packaging, or literature with the product. Moreover, a Prop 65 warning does not mean that a product is in violation of any product safety standards or requirements. In fact, the California government has clarified that a Prop 65 warning "is not the same as a regulatory decision that a product is 'safe' or 'unsafe.'" Many of these chemicals have been used in everyday products for years without documented harm. For more information, go to <https://oag.ca.gov/prop65/faqs-view-all>.

A Prop 65 warning means that a company has either (1) evaluated the exposure and has concluded that it exceeds the "no significant risk level"; or (2) has chosen to provide a warning based on its understanding about the presence of a listed chemical without attempting to evaluate the exposure.

Does this law apply everywhere?

Prop 65 warnings are required under California law only. These warnings are seen throughout California in a wide range of settings, including but not limited to restaurants, grocery stores, hotels, schools, and hospitals, and on a wide variety of products. Additionally, some online and mail order retailers provide Prop 65 warnings on their websites or in catalogs.

How do the California warnings compare to federal limits?

Prop 65 standards are often more stringent than federal and international standards. There are various substances that require a Prop 65 warning at levels that are far lower than federal action limits. For example, the Prop 65 standard for warnings for lead is 0.5 µg/day, which is well below the federal and international standards.

Why don't all similar products carry the warning?

- Products sold in California require Prop 65 labelling while similar products sold elsewhere do not.
- A company involved in a Prop 65 lawsuit reaching a settlement may be required to use Prop 65 warnings for its products, but other companies making similar products may have no such requirement.
- The enforcement of Prop 65 is inconsistent.
- Companies may elect not to provide warnings because they conclude that they are not required to do so under Prop 65; a lack of warnings for a product does not mean that the product is free of listed chemicals at similar levels.

Why does Toro include this warning?

Toro has chosen to provide consumers with as much information as possible so that they can make informed decisions about the products they buy and use. Toro provides warnings in certain cases based on its knowledge of the presence of one or more listed chemicals without evaluating the level of exposure, as not all the listed chemicals provide exposure limit requirements. While the exposure from Toro products may be negligible or well within the "no significant risk" range, out of an abundance of caution, Toro has elected to provide the Prop 65 warnings. Moreover, if Toro does not provide these warnings, it could be sued by the State of California or by private parties seeking to enforce Prop 65 and subject to substantial penalties.