



Mid-Size ProLine, Pistol Grip, Hydro Drive 15 HP with 36in Side Discharge Mower

Model No. 30433 - 250000001 and up.

Parts Catalog

Ordering Replacement Parts

To order replacement parts, please supply the part number, the quantity, and the description of each part desired.

Understanding Reference Numbers

Each identified part in an illustration has a reference number. The reference number for a part also appears in the parts list, along with other information about the part.

This catalog uses two special reference number formats, one to indicate parts in a service assembly and another to indicate the quantity of a given part in an illustration.

Service Assembly Reference Numbers

Parts in service assemblies have reference numbers in the form a:b. The a represents the reference number of the entire service assembly and the b represents a sequential number unique to each part within the service assembly.

For example, a wheel assembly might be identified by reference number 6, the tire by 6:1, the valve by 6:2, and the wheel by 6:3. When you order the assembly identified by reference number 6, you receive all parts identified by reference numbers 6:1, 6:2, and 6:3. However, you may also order any part individually. Reference numbers of this type appear in illustrations and in part lists.

Reference Numbers Indicating Quantity

In an illustration, if a reference number indicates more than one part, the reference number has the form nX y. The n represents the quantity of the part, the X is the multiplication symbol, and the y represents the reference number.

For example, in an illustration, the reference number 2X 37 means that two of the parts identified by reference number 37 are indicated.

Contents

Description	Page	Description	Page
Engine Installation Assembly 3	Crankshaft Assembly Kohler CV15T-41629 21
Fuel Tank Assembly 4	Crankcase Assembly Kohler CV15T-41629 22
Hydraulic Pump Assembly No. 106-5489 5	Oil Pan/Lubrication Assembly Kohler CV15T-41629 23
Hydraulic Pump Assembly No. 106-5490 6	Head/Valve/Breather Assembly Kohler CV15T-41629 24
Wheel and Drive Assembly 7	Ignition/Electrical Assembly Kohler CV15T-41629 25
Hydraulic Wheel Motor Assembly No. 104-1171 8	Blower Housing and Baffle Assembly Kohler CV15T-41629 26
Lower Control Assembly 9	Starting System Assembly Kohler CV15T-41629 27
Hydraulic Plumbing Assembly 10	Fuel System Assembly Kohler CV15T-41629 28
Upper Control Assembly 11	Engine Control Assembly Kohler CV15T-41629 29
Control Panel Assembly 12	Air Intake/Filtration Assembly Kohler CV15T-41629 30
Parking Brake Assembly 13	Exhaust Assembly Kohler CV15T-41629 31
Carrier Frame Assembly 14	Attachments and Accessories List 32
Spindle, Pulley and Belt Assembly 15		
Spindle Assembly No. 106-0785 16		
Outer Spindle Assembly 106-0787 17		
Deck Assembly 18		
Deflector Assembly No. 107-4194 19		
Drive Belt and Tensioner Assembly 20		

Part Description Abbreviations

Part descriptions in this catalog may include the following abbreviations.

AR. as required	HWHTF. hex washer head thread forming
ASM. assembly	HYD. hydraulic
CARR. carriage	INC. incorporated
DEG. degrees	LH. left hand
EXT. external	NI. nylon insert
FH. flat head	NPTF. national pipe thread fine
GA. gauge	PPH. phillips pan head
HF. hex flange	PRH. phillips round head
HH. hex head	PTH. phillips truss head
HHF. hex head flange	PTO. power take off
HHFTF. hex head flange thread forming	RH. right hand
HJ. hex jam	ROPS. roll over protection system
HLH. hex lag head	SFH. slotted fillister head
HOC. height-of-cut	SHH. slotted hex head
HS. hex	SHWH. slotted hex washer head
HSBH. hex socket button head	SPH. slotted pan head
HSFH. hex socket flat head	SQH. square head
HSH. hex socket head	SRH. slotted round head
HWH. hex washer head	STD. standard

Footnotes

- ❶ Not illustrated
- ❷ Not serviced separately
- ❸ Obtain Parts From Your Local Kohler Dealer

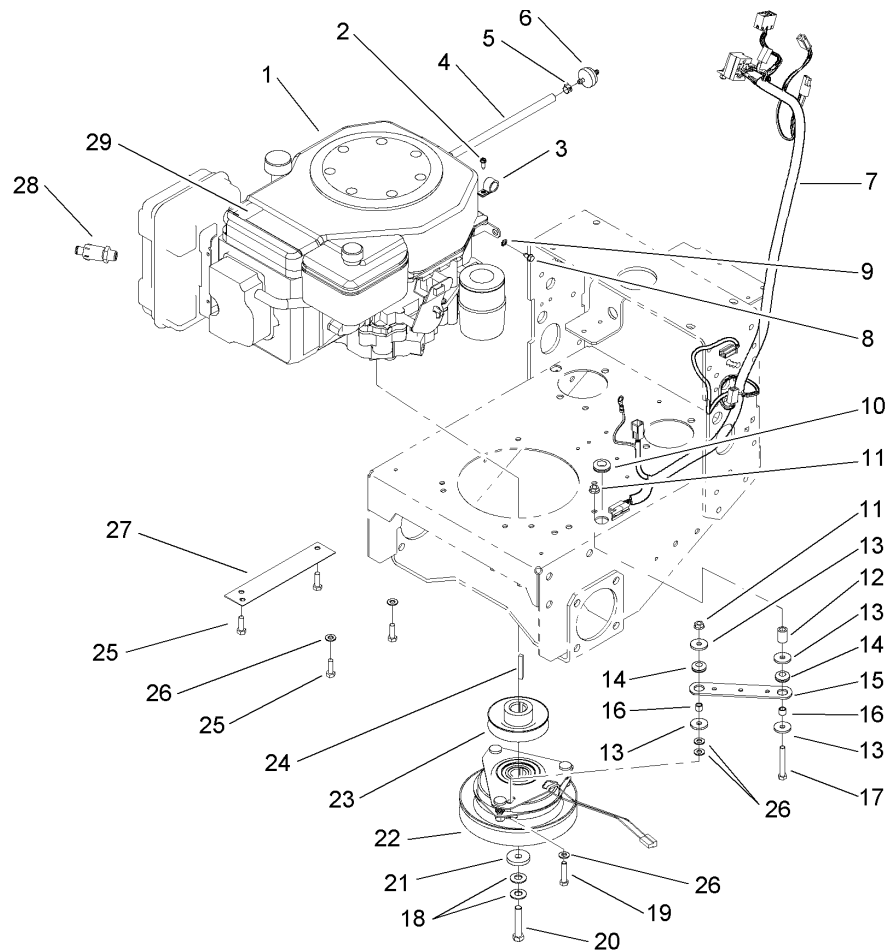

Engine Installation Assembly

Ref	Part No.	Qty.	Description	Ref	Part No.	Qty.	Description
② 1		1	Engine-Kohler, Cv15t-41629	25	33114-025	4	Screw-HH
2	32144-19	1	Screw-SHWH	26	3256-23	5	Washer-Flat
3	2412-87	1	Clamp-Cable	27	94-5847-01	1	Cover-Pulley
4	47-2982	1	Hose-Fuel	28	92-6877	1	Valve-Drain, Oil
5	2412-98	2	Clamp	29	106-0699	1	Decal-Warning, Hot Surfaces
6	56-6360	1	Filter-Fuel	① 99	103-1964	1	Hose-Drain, Oil
7	106-8782	1	Harness-Wire				
8	33104-025	1	Screw-HHF				
9	3255-8	1	Washer-Lock				
10	237-124	1	Grommet				
11	32128-20	2	Nut-HF				
12	104-6373	1	Tube-Retainer				
13	1-613235	4	Washer				
14	1-633630	2	Grommet-Brake				
15	1-633543-03	1	Strap-Clutch, Brake				
16	1-633545	2	Spacer				
17	322-11	1	Screw-HH				
18	1-603610	2	Washer-Spring				
19	322-7	1	Screw-HH				
20	3212-9	1	Screw-HH				
21	107-4136	1	Washer				
22	105-2635	1	Clutch / Brake				
23	44-5940	1	Pulley				
24	608006	1	Key-Square				

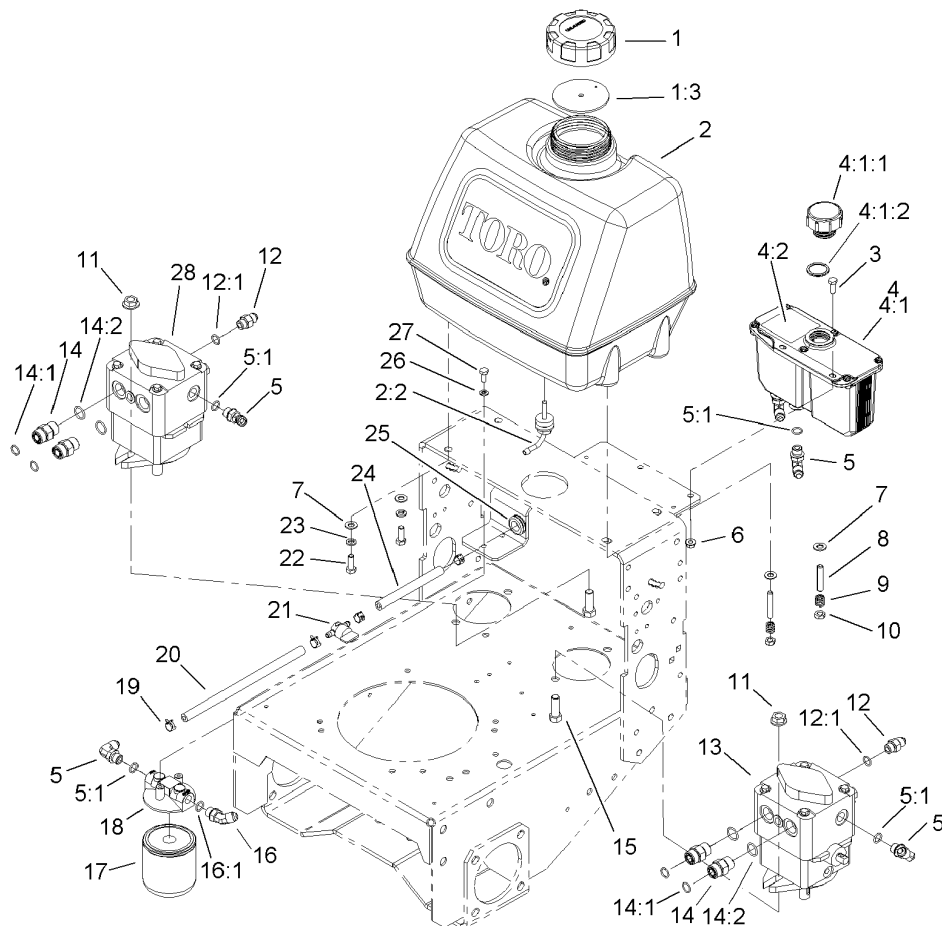

Fuel Tank Assembly

Ref	Part No.	Qty.	Description
1	88-3980	1	Gas Cap ASM
1:3	88-4010	1	Gasket-Cap, Gas
2	106-0730	1	Fuel Tank ASM
2:2	103-2605	1	Fitting-Fuel, Bulkhead
3	321-4	2	Screw-HH
4	103-1947	1	HYD Reservoir ASM
4:1		1	Reservoir-HYD
4:1:1	103-1948	1	Cap-Reservoir, HYD
4:1:2	103-1949	1	Gasket-Cap
4:2	1-523552	1	Decal-Tank, HYD
5	353-374	5	Elbow-90 DEG
5:1	237-42	1	O-Ring
6	32128-33	2	Nut-HF
7	3256-23	4	Washer-Flat
8	104-8121	2	Stud-Threaded
9	1-633349	2	Spring-Tank, Fuel
10	3296-47	2	Nut-Lock, NI
11	32128-42	4	Nut-HF
12	353-384	2	Fitting-Straight
12:1	237-42	1	O-Ring
13	106-5490	1	Pump-HYD
14	340-4	4	Fitting-Hyd, Straight
14:1	237-30	1	O-Ring
14:2	237-79	1	O-Ring

Ref	Part No.	Qty.	Description
15	324-5	4	Screw-HH
16	353-212	1	Elbow
16:1	237-42	1	O-Ring
17	1-633752	1	Filter-Hyd, Winter
17	1-633750	1	Filter-HYD
18	104-7836	1	Head-Filter
19	2412-98	4	Clamp
20	47-2982	1	Hose-Fuel
21	1-603770	1	Valve-Fuel
22	322-4	2	Screw-HH
23	3253-4	2	Washer-Lock
24	47-2966	1	Hose-Fuel
25	237-124	1	Grommet
26	3253-3	2	Washer-Lock
27	321-3	2	Screw-HH
28	106-5489	1	Pump-HYD

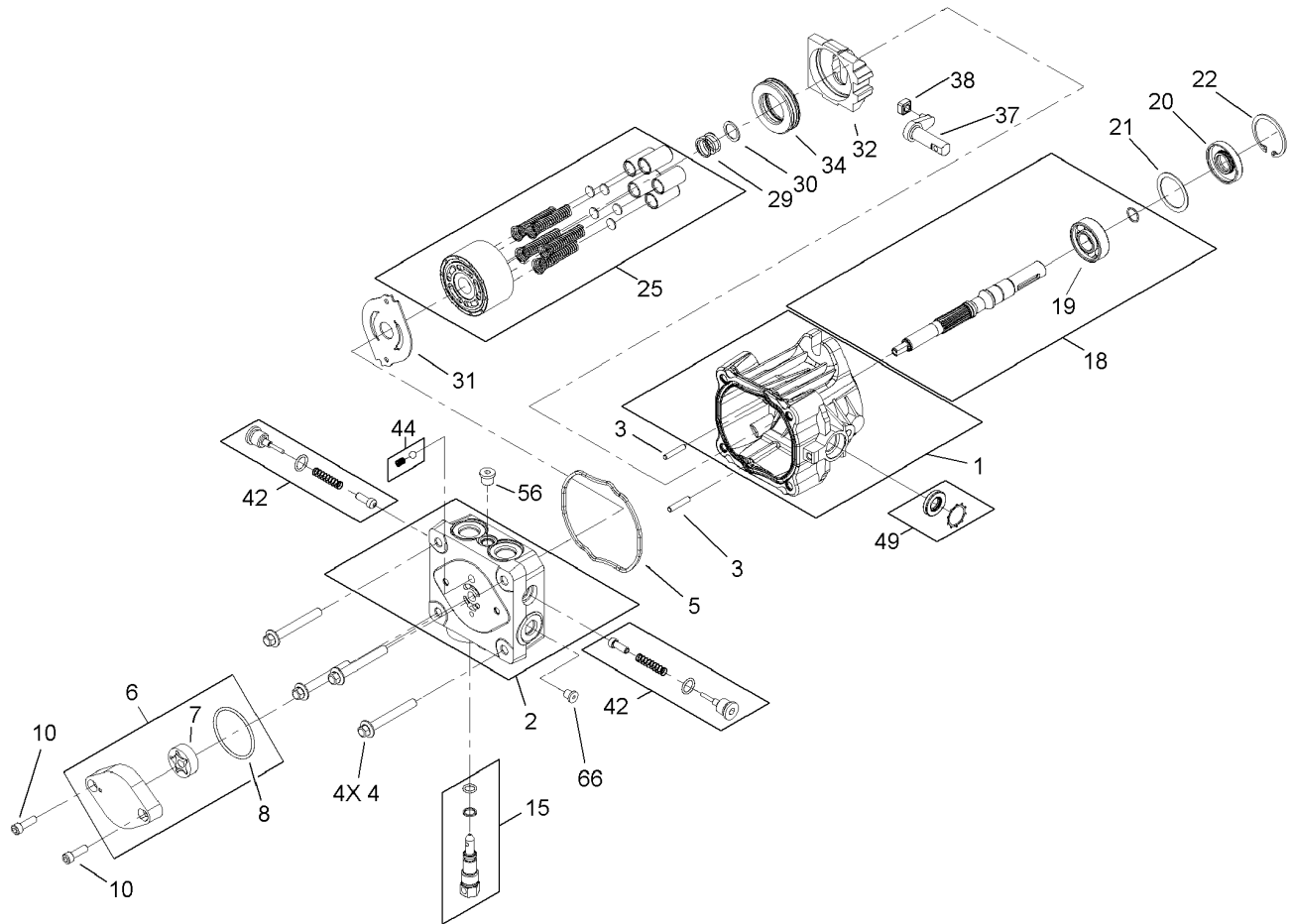

Hydraulic Pump Assembly No. 106-5489

Ref	Part No.	Qty.	Description
1	106-8751	1	Housing Kit
2	106-8752	1	End Cap Kit (W/poppets)
3	106-8753	2	Pin-Headless, Straight
4	106-8754	4	Bolt-HF
5	106-8755	1	O-Ring
6	106-8756	1	Charge Pump Kit
7	104-2122	1	Gerotor ASM
8	106-8757	1	O-Ring
10	106-8758	2	Screw-HSH
15	106-8759	1	Bypass Valve Kit
18	103-2664	1	Input Shaft Kit
19	104-5311	1	Bearing-Ball
20	104-5310	1	Seal-Lip
21	104-5308	1	Spacer
22	104-5309	1	Ring-Retaining
25	104-2106	1	Cylinder Block ASM
29	94-1936	1	Spring-Block
30	94-1937	1	Washer-Block, Thrust
31	105-6185	1	Plate-Valve
32	94-1907	1	Swashplate-Variable
34	94-6922	1	Bearing-Thrust
37	94-1909	1	Arm-Trunion
38	94-1910	1	Guide-Slot
42	98-3252	2	Valve-Check (W/poppet)

Ref	Part No.	Qty.	Description
44	106-8760	1	Charge Relief Valve Kit
49	106-8761	1	Trunion Seal/retainer Kit
56	106-8762	1	Plug-HSH
66	106-8763	1	Plug-HSH
99	105-6184	1	Seal Kit

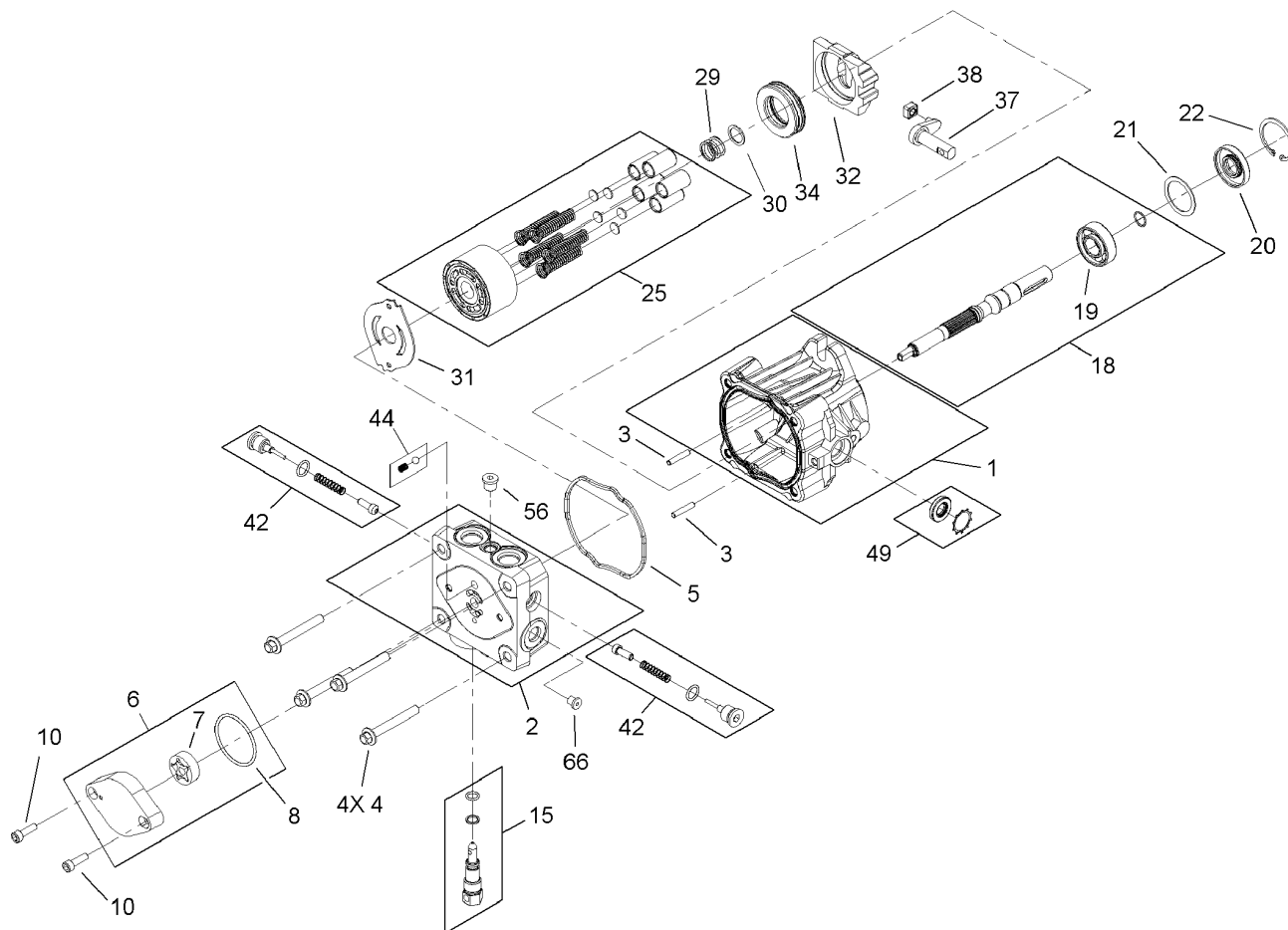

Hydraulic Pump Assembly No. 106-5490

Ref	Part No.	Qty.	Description
1	106-8751	1	Housing Kit
2	106-8752	1	End Cap Kit (W/poppets)
3	106-8753	2	Pin-Headless, Straight
4	106-8754	4	Bolt-HF
5	106-8755	1	O-Ring
6	106-8756	1	Charge Pump Kit
7	104-2122	1	Gerotor ASM
8	106-8757	1	O-Ring
10	106-8758	2	Screw-HSH
15	106-8759	1	Bypass Valve Kit
18	103-2664	1	Input Shaft Kit
19	104-5311	1	Bearing-Ball
20	104-5310	1	Seal-Lip
21	104-5308	1	Spacer
22	104-5309	1	Ring-Retaining
25	104-2106	1	Cylinder Block ASM
29	94-1936	1	Spring-Block
30	94-1937	1	Washer-Block, Thrust
31	105-6185	1	Plate-Valve
32	94-1907	1	Swashplate-Variable
34	94-6922	1	Bearing-Thrust
37	94-1909	1	Arm-Trunion
38	94-1910	1	Guide-Slot
42	98-3252	2	Valve-Check (W/poppet)

Ref	Part No.	Qty.	Description
44	106-8760	1	Charge Relief Valve Kit
49	106-8761	1	Trunion Seal/retainer Kit
56	106-8762	1	Plug-HSH
66	106-8763	1	Plug-HSH
99	105-6184	1	Seal Kit

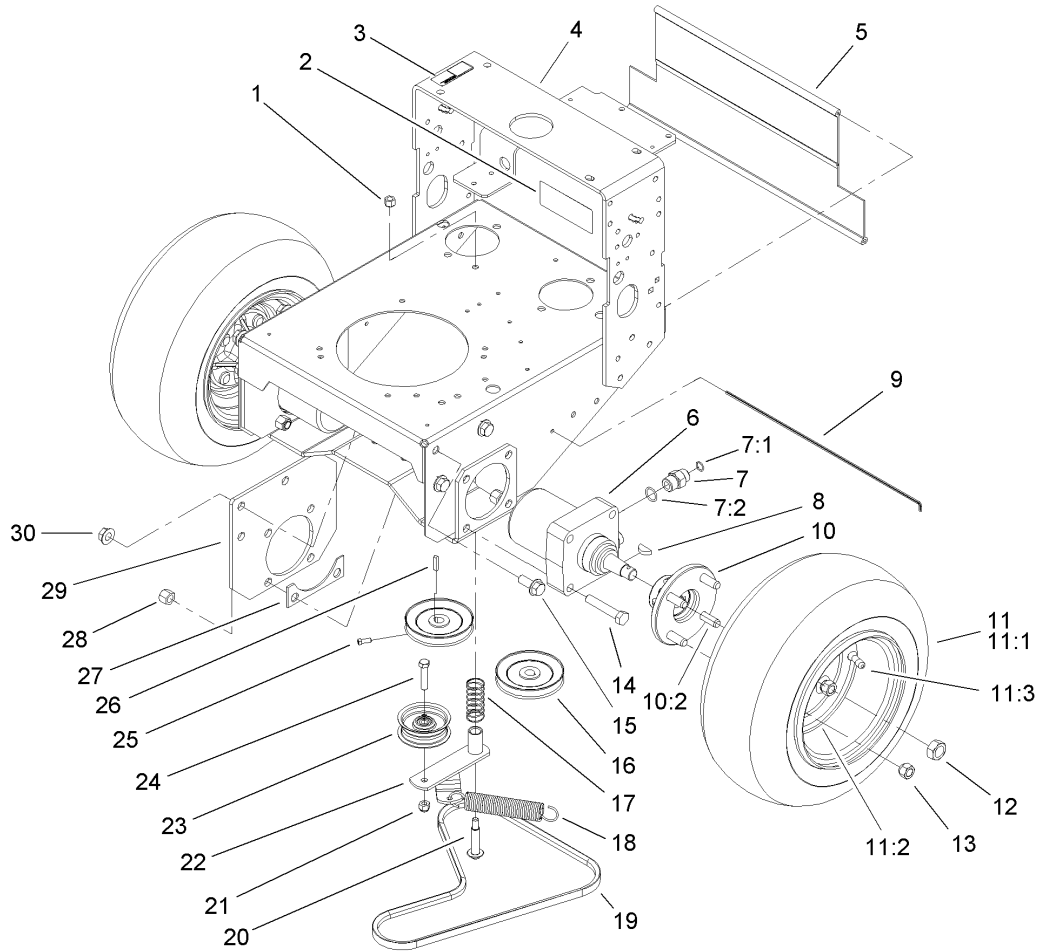

Wheel and Drive Assembly

Ref	Part No.	Qty.	Description
1	3296-6	1	Nut-Lock
2	98-0776	1	Decal-Caution
3	95-2814	1	Decal-Shut Off, Fuel
4	106-0548-01	1	Hydro Frame ASM
5	95-1526	1	Shield-Trailing
6	104-1171	2	Motor-Wheel
7	340-6	4	Fitting-Hyd, Straight
7:1	237-30	1	O-Ring
7:2	237-80	1	O-Ring
8	3257-8	2	Key-Woodruff
9	95-1529	1	Rod-Shield
10	105-0800	2	Wheel Hub / Stud ASM
10:2	10-6830	4	Stud-Type, Drive
11	106-0892	2	Wheel And Tire ASM
11:1	104-6322	1	Tire
11:2	106-0893	1	Wheel
11:3	232-27	1	Stem-Valve
12	85-7310	2	Nut-Motor, Wheel
13	242-50	8	Nut-Lug
14	325-11	8	Screw-HH
15	3234-32	6	Screw-HHF
16	105-5648	2	Pulley-Pump
17	88-1880	1	Spring-Compression
18	68-2190	1	Spring

Ref	Part No.	Qty.	Description
19	105-5649	1	V-Belt
20	27-6230	1	Bolt-Wheel
21	3296-39	1	Nut-Lock, NI
22	86-4770	1	Idler Lever ASM
23	62-4540	1	Pulley
24	323-9	1	Screw-HH
25	3241-5	4	Screw-Set
26	80-6090	2	Key-Pump
27	86-4740-01	2	Spacer-Frame
28	3296-23	8	Nut-Lock, NI
29	105-5643-01	2	Plate-Frame
30	32128-23	6	Nut-HF

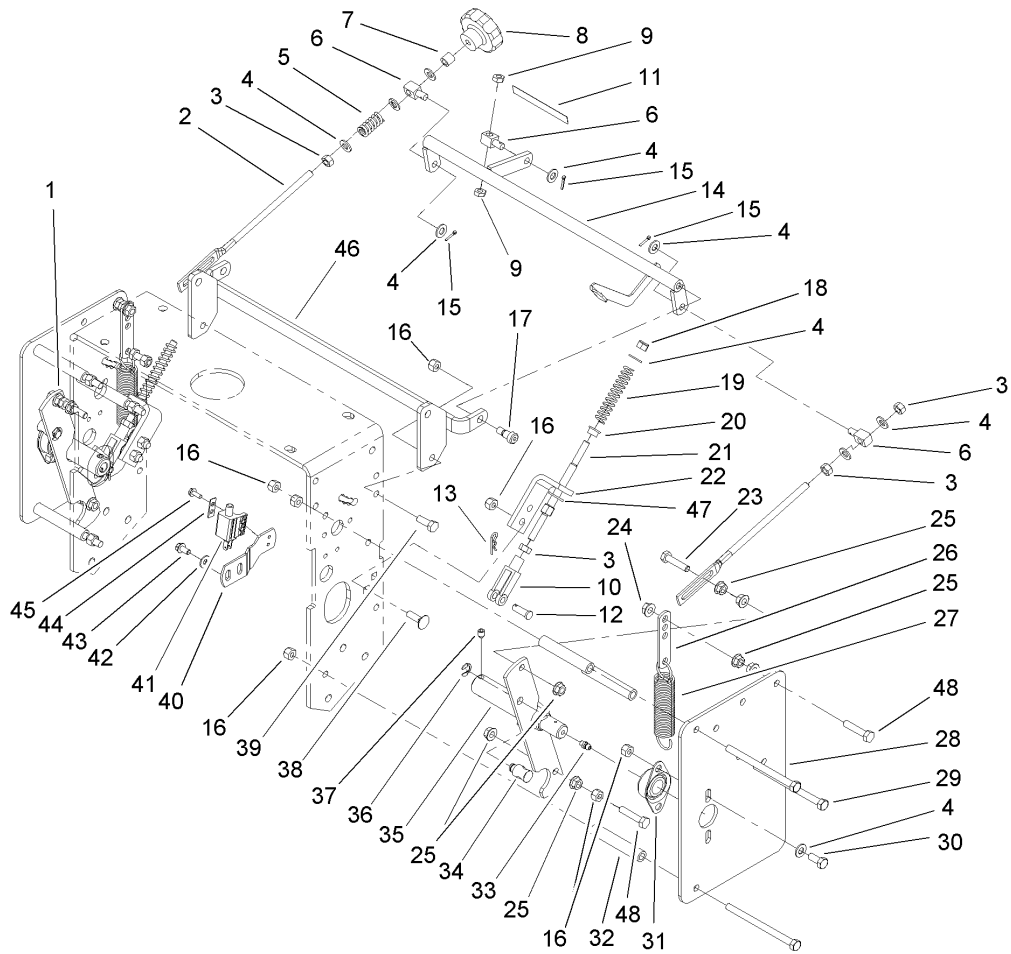

Lower Control Assembly

Ref	Part No.	Qty.	Description
1	106-5484	1	RH Control Arm ASM
2	1-413350	2	Link-Control, Speed
3	3219-2	5	Nut-Hex
4	3256-23	14	Washer-Flat
5	1-323245	1	Spring-Compression
6	1-603676	3	Swivel-Adjustable, Short
7	1-603903	1	Spacer
8	1-413151	1	Knob-Tracking
9	3220-2	2	Nut
10	1-303105	2	Yoke-Adjustable
11	105-4109	1	Decal-Tracking
12	1-808280	2	Pin-Clevis
13	3290-307	2	Pin-Hair
14	106-5538-01	1	Speed Control Crank ASM
15	3272-5	3	Pin-Cotter
16	3296-29	18	Nut-Lock, NI
17	1-809056	2	Screw
18	3296-4	2	Nut-Lock
19	1-603807	2	Spring-Return, Neutral
20	1-603735	2	Bushing-Flanged
21	105-9372	2	Stud-Adjustment
22	104-9802-01	2	Bracket-Mount, Spring
23	1-403180	2	Screw-HH
24	32128-25	2	Nut-HF

Ref	Part No.	Qty.	Description
25	32128-20	14	Nut-HF
26	1-613089	2	Tab-Spring, Extension.
27	1-603693	2	Spring-Extension
28	104-9817-01	2	Plate-Side, Hydro
29	322-38	6	Screw-HH
30	322-3	4	Screw-HH
31	1-633102	2	Bearing-Flange, Side
32	104-9820	6	Spacer-Shield
33	302-5	2	Fitting-Grease
34	103-1235	2	Swivel-Lever, Drive
35	106-5480	1	LH Control Arm ASM
36	32151-47	2	Ring-Retaining
37	3246-3	4	Screw-HS
38	3230-2	4	Bolt-CARR
39	322-4	2	Screw-HH
40	106-5539-01	1	Bracket-Neutral
41	95-1653	1	Switch-Pole, Single
42	3256-1	2	Washer-Flat
43	32144-4	2	Screw-HWH
44	82-4570	1	Plate-Switch
45	32144-1	2	Screw-Taprite
46	105-3163-01	1	Crank Support ASM
47	3256-24	2	Washer-Flat
48	1-800016	4	Bolt-Tap, HH

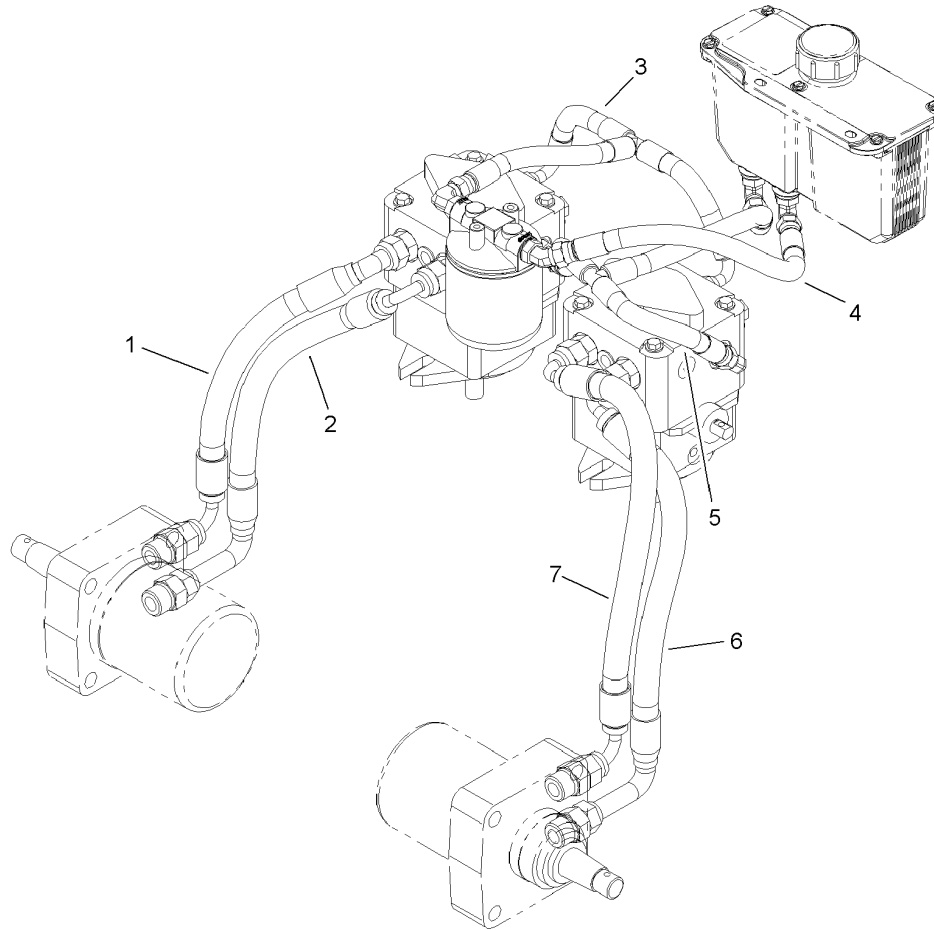

Hydraulic Plumbing Assembly

Ref	Part No.	Qty.	Description
1	106-0824	1	HYD Hose ASM
2	106-0825	1	HYD Hose ASM
3	105-5697	1	HYD Hose ASM
4	105-5699	1	HYD Hose ASM
5	105-5698	1	HYD Hose ASM
6	106-3368	1	HYD Hose ASM
7	106-0826	1	HYD Hose ASM

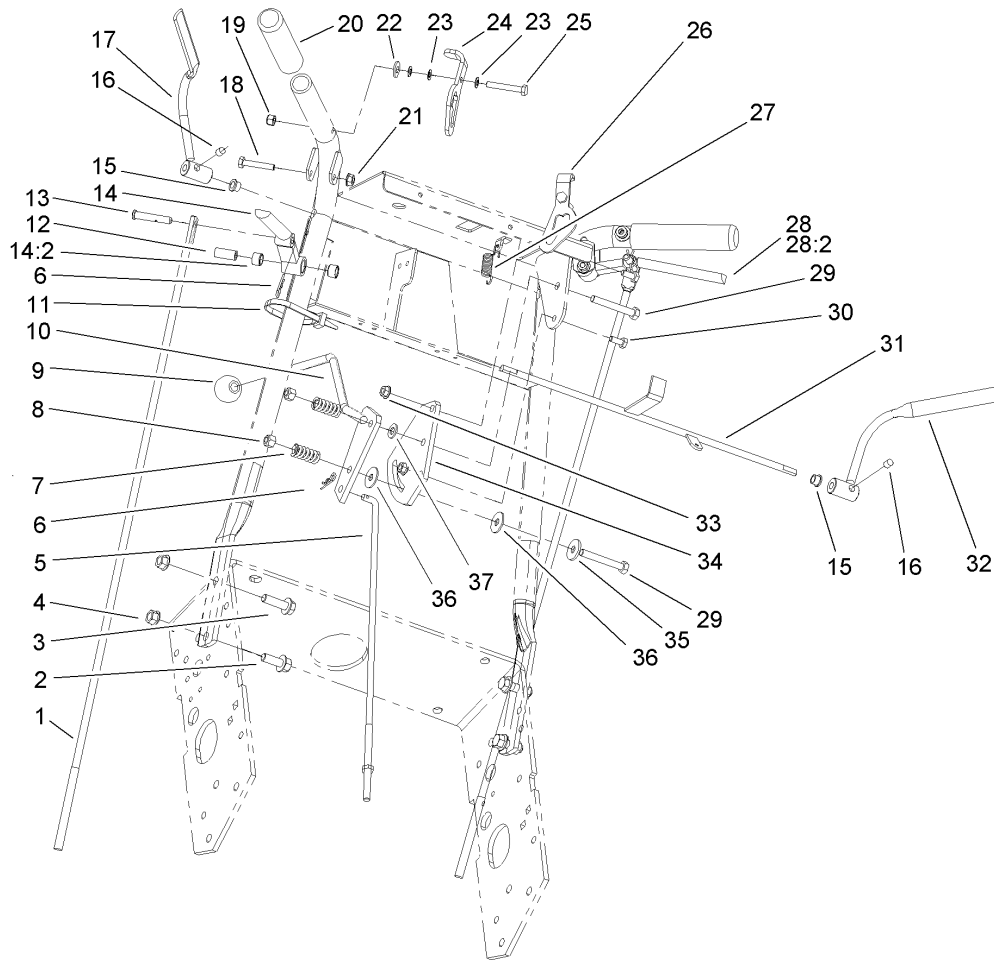

Upper Control Assembly

Ref	Part No.	Qty.	Description	Ref	Part No.	Qty.	Description
1	1-413219	2	Rod-Lever, Drive	24	106-5483	1	Latch-Thumb, LH
2	3234-11	2	Screw-HHF	25	321-10	2	Screw-HH
3	3234-24	2	Screw-HHF	26	106-5481	1	Latch-Thumb, RH
4	32128-21	4	Nut-HF	27	1-303363	1	Spring-Extension
5	106-5534	1	Rod-Control, Speed	28	103-0219	1	RH Drive Lever ASM
6	3290-307	3	Pin-Hair	28:2	1-413152	2	Sleeve-Bushing
7	1-323245	2	Spring-Compression	29	322-11	2	Screw-HH
8	3296-29	2	Nut-Lock, NI	30	321-3	2	Screw-HH
9	233-42	1	Knob	31	104-9803	1	Rod ASM
10	106-2748	1	Lever-Shift	32	106-5486	1	RH Opc Lever ASM
11	3290-378	1	Tie-Cable	33	32128-33	2	Nut-HF
12	1-603749	2	Bushing-Lever, Drive	34	1-603730	1	Plate-Lever, Shifter
13	1-613055	2	Pin-Clevis	35	1-603716	1	Washer-Friction
14	103-0218	1	LH Drive Lever ASM	36	1-323244	2	Washer-Friction
14:2	1-413152	2	Sleeve-Bushing	37	3256-23	1	Washer-Flat
15	1-303365	2	Bushing-Nylon				
16	1-803322	2	Screw-Set				
17	106-5485	1	LH Opc Lever ASM				
18	321-9	2	Screw-HH				
19	3296-42	2	Nut-Lock, NI				
20	104-9838	2	Grip-Foam				
21	32128-33	2	Nut-HF				
22	3256-2	2	Washer-Flat				
23	1-303435	6	Washer-Spring				

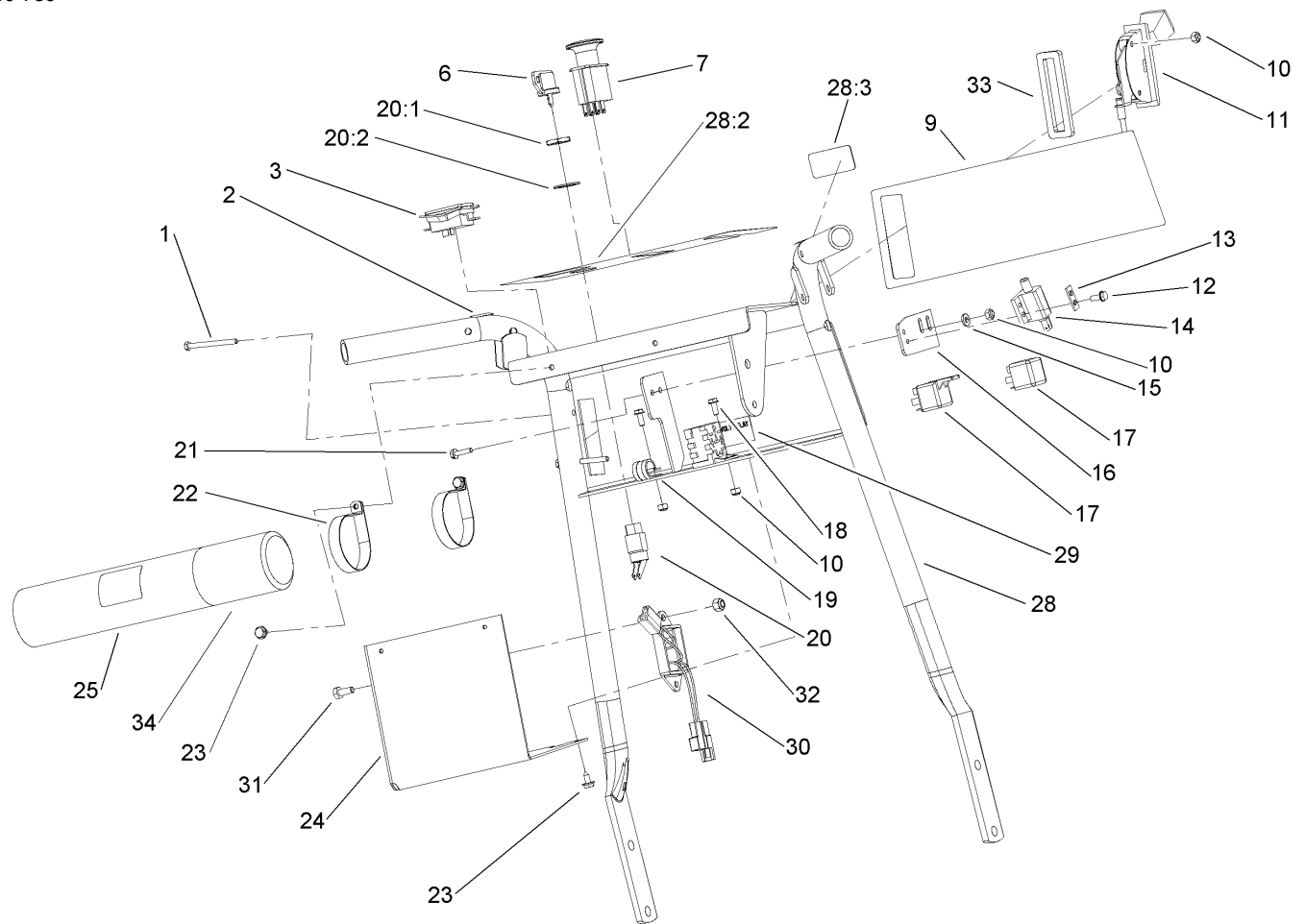

Control Panel Assembly

Ref	Part No.	Qty.	Description
1	32105-14	2	Screw-SHH
2	105-4110	2	Decal-Lock, Neutral
3	104-8143	1	Hourmeter
6	63-8360	1	Key-Ignition
7	95-7489	1	Switch-PTO
9	106-5501	1	Decal-Control, Throttle
10	3296-2	6	Nut-Lock
11	107-4073	1	Cable-Throttle
12	32144-1	2	Screw-Taptite
13	82-4570	1	Plate-Switch
14	95-1653	1	Switch-Pole, Single
15	3256-14	2	Washer-Flat
16	105-4137-03	1	Plate-Mounting, Switch
17	105-4145	1	Relay
18	3290-321	2	Screw-HWH
19	2412-134	1	R-Clamp
20	29-5560	1	Switch-On / Off
20:1	218-461	1	Nut-HH
20:2	3254-5	1	Washer-Tooth
21	32105-13	2	Screw-SHH
22	2412-120	2	R-Clamp
23	32104-76	4	Screw
24	105-4112-03	1	Bracket-Cover
25	104-7050	1	Housing-Manual

Ref	Part No.	Qty.	Description
28	105-3175	1	Handle ASM
28:2	106-5515	1	Decal-Panel, Control
28:3	98-4387	1	Decal-Protection, Ear
29	105-4146	1	Decal-Relay, 24 Volt
30	105-4608	1	Module-Filter
31	321-3	2	Screw-HH
32	3296-42	2	Nut-Lock, NI
33	106-5487	1	Gasket-Throttle
34	104-7048	1	Cap-Housing

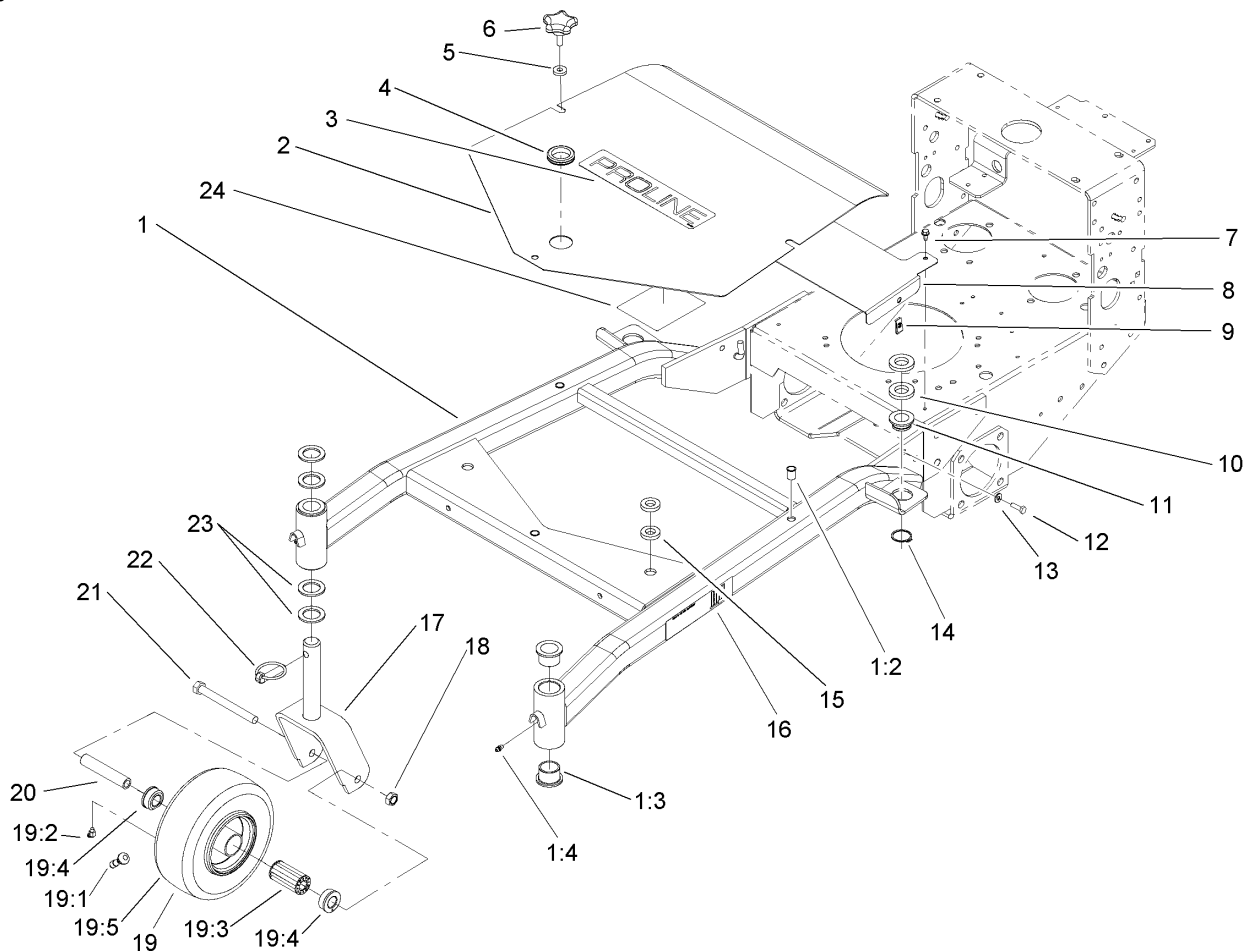

Carrier Frame Assembly

Ref	Part No.	Qty.	Description
1	106-0706	1	Carrier Frame ASM
1:2	32148-9	3	Insert-Nut
1:3	94-1291	4	Bushing
1:4	302-5	2	Fitting-Grease
2	105-3165-01	1	Cover-Frame, Carrier
3	106-0719	1	Decal
4	240-3	1	Grommet-Rubber
5	106-0565	3	Washer-Rubber
6	106-0887	3	Knob
7	12-3270	2	Screw
8	106-5473-01	1	Shield-Heat
9	3290-199	2	Nut-Speed
10	104-1105	4	Spacer-Support, Deck
11	1-513336	2	Bushing-Deck
12	321-5	2	Screw-HH
13	3256-22	2	Washer-Flat
14	32120-33	2	Ring-Retaining
15	105-0842	4	Spacer
16	106-0635	2	Decal-HOC
17	105-3159-01	2	Castor Fork ASM
18	32153-5	2	Nut-Lock, Side
19	100-6451	2	Castor Wheel ASM
19:1	232-27	1	Stem-Valve
19:2	302-11	1	Fitting-Lube, 45 DEG

Ref	Part No.	Qty.	Description
19:3	83-4740	1	Bearing
19:4	62-5580	2	Bearing-Outside
19:5	100-6452	1	Tire-Tubeless
20	100-6453	2	Bushing-Spanner
21	325-19	2	Screw-HH
22	283-71	2	Pin-Lynch
23	3-6781	8	Washer-Thrust
24	106-5512	1	Decal-Hydro, Pistol Grip
24	106-5510	1	Decal-Gear, Pistol Grip
24	106-5506	1	Decal-Gear, Tbar
24	106-5504	1	Decal-Hydro, Tbar

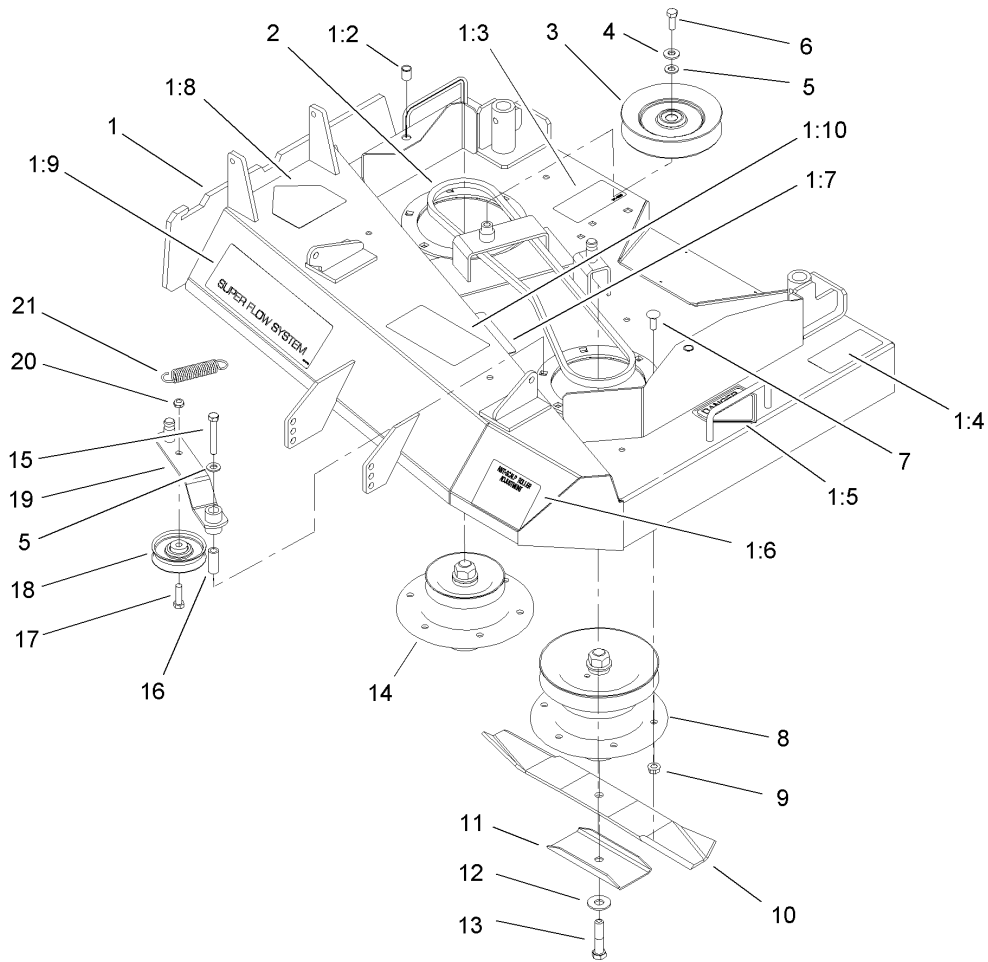

Spindle, Pulley and Belt Assembly

Ref	Part No.	Qty.	Description
1	106-0615	1	36in Deck ASM
1:2	32148-9	2	Insert-Nut
1:3	104-8185	1	Decal
1:4	68-8340	1	Decal-Torque
1:5	43-8480	1	Decal-Danger
1:6	106-5532	1	Decal-Anti Scalp
1:7	67-5360	1	Decal-Danger
1:8	93-1122	1	Decal-Danger
1:9	106-0703	1	Decal
1:10	66-1340	1	Decal-Danger
2	51-3530	1	V-Belt-Drive, Deck
3	1-633166	1	Pulley-Idler
4	98-5975	1	Washer-Belleville
5	3256-24	2	Washer-Flat
6	323-6	1	Screw-HH
7	3231-22	11	Screw-CARR
8	106-0785	1	Spindle Housing ASM
9	32128-21	12	Nut-HF
10	56-2390	2	Blade-Sail, Extra High
11	92-9820	2	Stiffener-Blade
12	3256-6	2	Washer-Flat
13	44-2200	2	Screw-Blade
14	106-0787	1	Spindle Housing ASM
15	323-12	1	Screw-HH

Ref	Part No.	Qty.	Description
16	51-3641	1	Sleeve-Pivot, Idler
17	3211-5	1	Screw-HH
18	51-3660	1	Pulley-Idler
19	105-0889	1	Idler Arm ASM
20	3296-5	1	Nut-Lock
21	105-2673	1	Spring-Extension

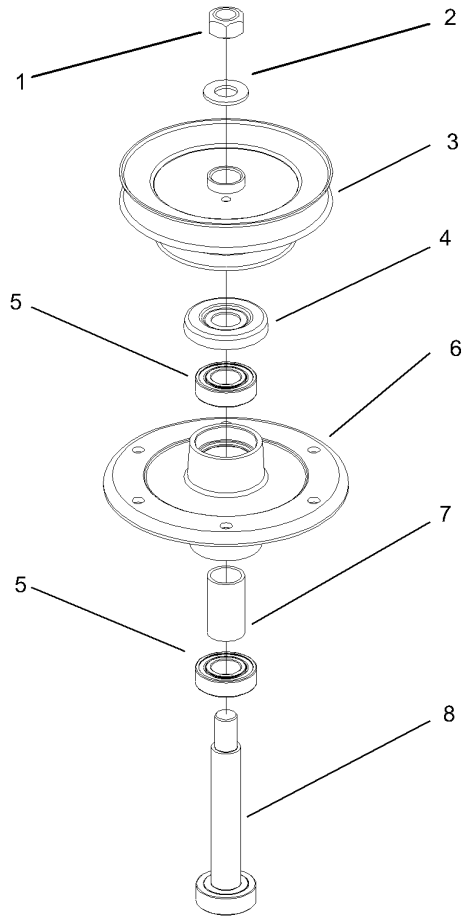

Spindle Assembly No. 106-0785

Ref	Part No.	Qty.	Description
1	3219-7	1	Nut-Hex
2	7-4150	1	Washer
3	104-1117	1	Pulley And Hub ASM
4	106-0873	1	Shield-Bearing
5	104-6325	2	Bearing
6	106-0819	1	Housing-Spindle
7	106-0795	1	Spacer-Bearing
8	106-0781	1	Shaft-Spindle

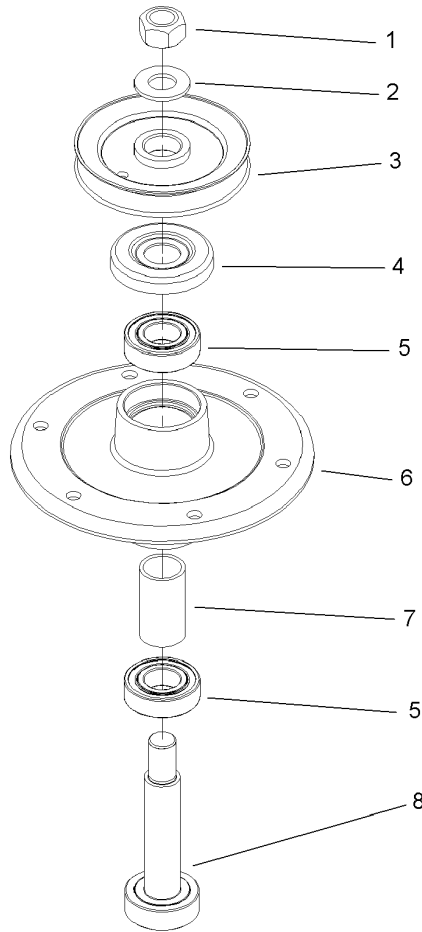

Outer Spindle Assembly 106-0787

Ref	Part No.	Qty.	Description	
1	3219-7	1	Nut-Hex	
2	7-4150	1	Washer	
3	104-1118	1	Pulley And Hub ASM	
4	106-0873	1	Shield-Bearing	
5	104-6325	2	Bearing	
6	106-0819	1	Housing-Spindle	
7	106-0795	1	Spacer-Bearing	
8	106-0782	1	Shaft-Spindle	

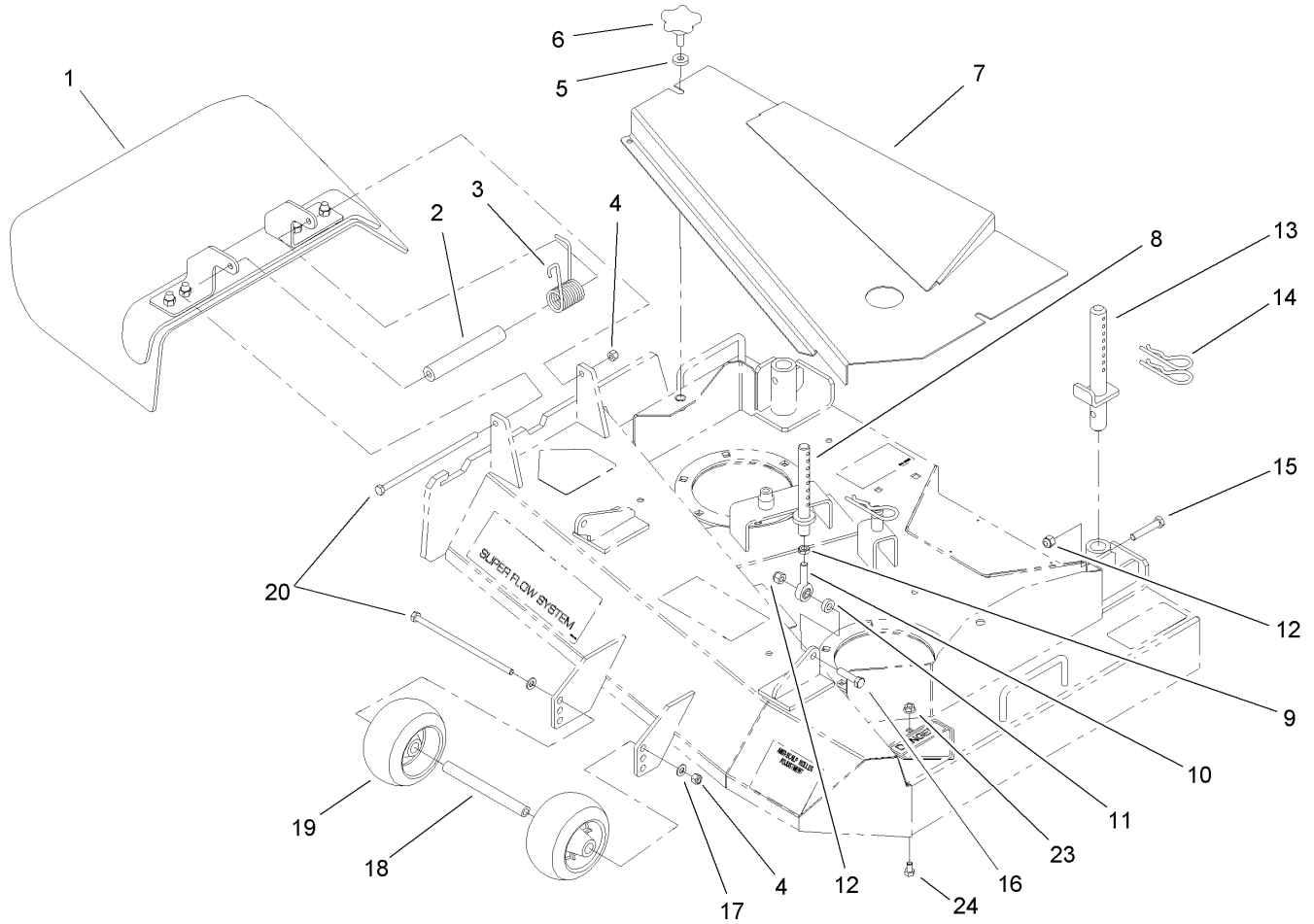

Deck Assembly

Ref	Part No.	Qty.	Description
1	107-4194	1	Deflector ASM
2	105-4622	1	Spacer
3	104-8554	1	Spring-Torsion
4	3296-29	2	Nut-Lock, NI
5	106-0565	2	Washer-Rubber
6	106-0887	2	Knob
7	106-5475-01	1	Cover ASM
8	106-0684	2	Front Pin ASM
9	3220-3	2	Nut-Jam
10	1-613204	2	Balljoint
11	104-1156	2	Spacer
12	3296-39	4	Nut-Lock, NI
13	106-3365	2	Rear Pin ASM
14	3290-256	6	Pin-Hair
15	323-10	2	Screw-HH
16	323-8	2	Screw-HH
17	3256-23	2	Washer-Flat
18	98-5967	1	Spacer-Wheel
19	1-603299	2	Roller-Anti Scalp
20	322-50	2	Screw-HH
23	32128-20	2	Nut-HF
24	322-1	2	Screw-HH

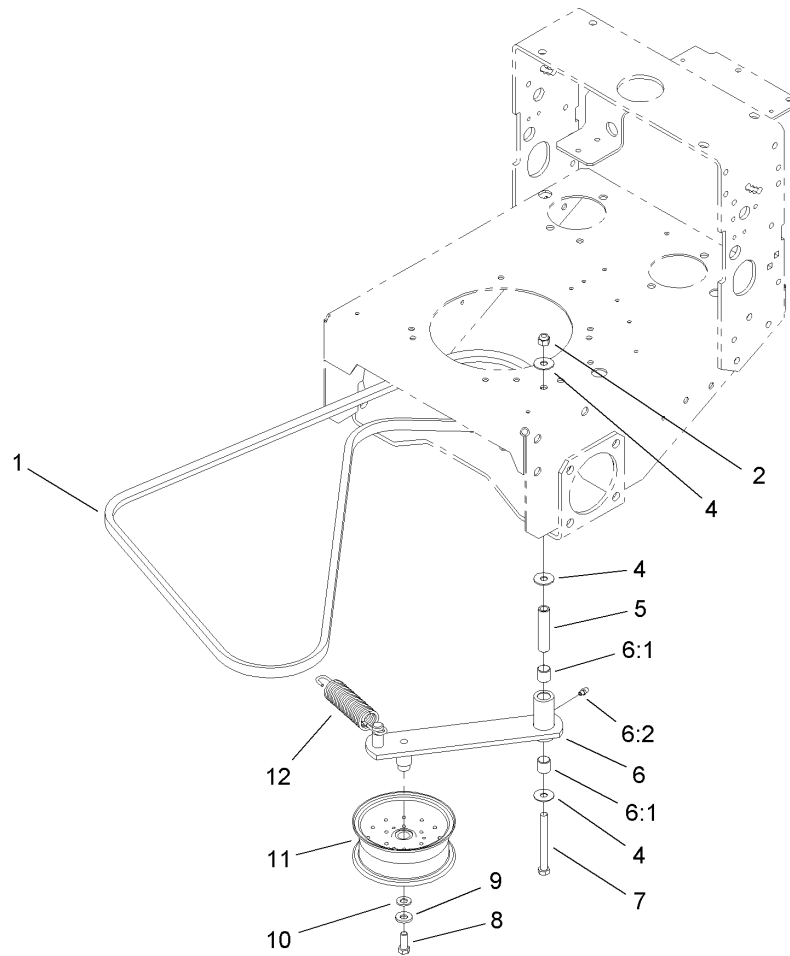

Drive Belt and Tensioner Assembly

Ref	Part No.	Qty.	Description
1	106-5492	1	Belt-Drive, PTO
2	3296-39	1	Nut-Lock, NI
4	52-2860	3	Washer-Flat
5	104-6377	1	Tube-Idler
6	106-0734	1	Idler Arm ASM
6:1	1-513034	2	Sleeve-Bearing
6:2	302-5	1	Fitting-Grease
7	323-42	1	Screw-HH
8	323-6	1	Screw-HH
9	98-5975	1	Washer-Belleville
10	3256-24	1	Washer-Flat
11	1-413099	1	Pulley-Idler
12	105-8443	1	Spring-Extension

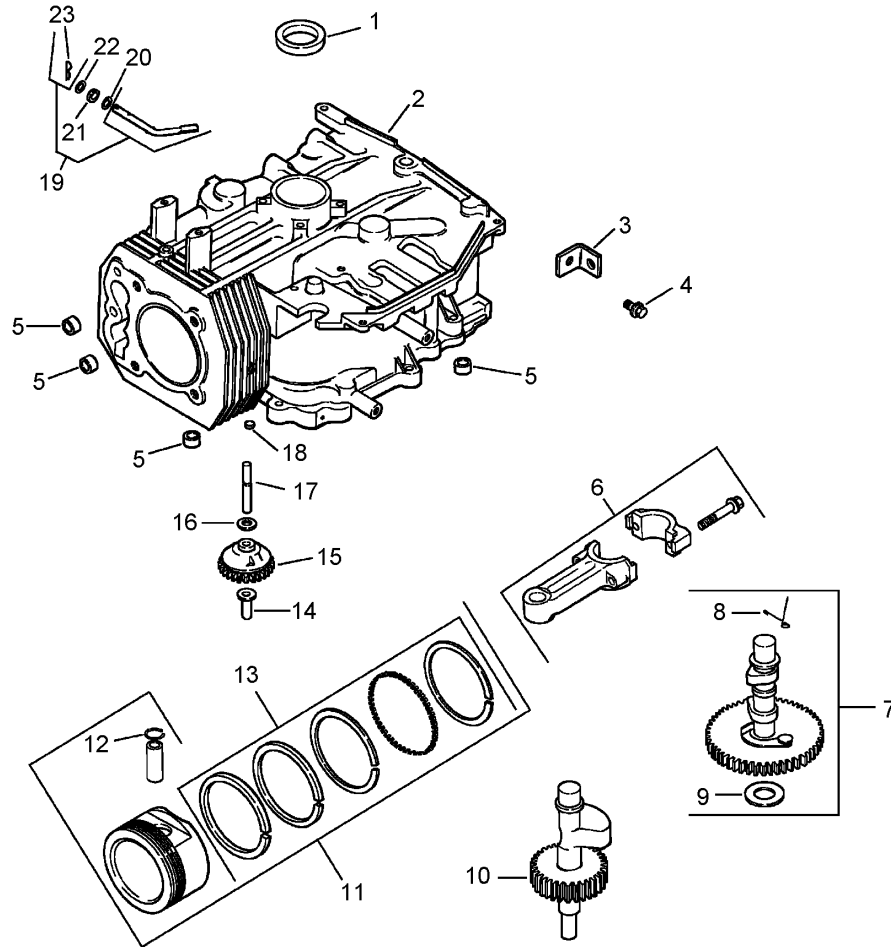

Crankcase Assembly Kohler CV15T-41629

Ref	Part No.	Qty.	Description
1	12 032 03-S	1	Seal-Oil, Front
2		1	Crankcase (Use: Short Block 12 522 18)
3	12 445 02-S	1	Strap-Lifting
4	M-839025-S	1	Screw-HF (M8x1.25x25)
5	24 380 13-S	4	Pin-Locating
6	12 067 05-S	1	Rod-Connecting (Std.)
7	12 067 06-S	1	Rod-Connecting (.25)
8	12 755 49-S	1	Camshaft Kit (Includes 8,9)
9	12 089 31-S	1	Spring-Actuating
10	12 422 08-S	1	Shim-Camshaft, Blue
11	12 422 09-S	1	Shim-Camshaft, Red
12	12 422 10-S	1	Shim-Camshaft, Yellow
13	12 422 11-S	1	Shim-Camshaft, Green
14	12 422 12-S	1	Shim-Camshaft, Gray
15	12 422 13-S	1	Shim-Camshaft, Black
16	12 422 07-S	1	Shim-Camshaft, White
17	12 144 27-S	1	Shaft-Balance
18	12 874 07-S	1	Piston W/ring Set (Std) (Includes 12-13)
19	12 874 11-S	1	Piston W/ring Set (.08)
20	12 874 08-S	1	Piston W/ring Set (.25)
21	12 874 09-S	1	Piston W/ring Set (.50)
22	12 018 02-S	2	Retainer-Pin, Piston

Ref	Part No.	Qty.	Description
13	12 108 07-S	1	Ring Set (Std. And .08)
14	12 108 08-S	1	Ring Set (.25)
15	12 108 09-S	1	Ring Set (.50)
16	12 380 01-S	1	Pin-Regulating, Governor
17	12 043 05-S	1	Gear-Governor
18	M-631005-S	1	Washer-Plain (6mm)
19	12 144 02-S	1	Shaft-Gear, Governor
20	52 139 09-S	1	Plug-Cup
21	12 755 64-S	1	Governor Cross Shaft Kit (Includes 23)
22	X-25-102-S	1	Washer-Plain, 1/4in
23	12 032 01-S	1	Seal-Cross Shaft, Governor
24	M-631015-S	1	Washer-Plain (6mm)
25	12 154 05-S	1	Clip-Pin, Hitch

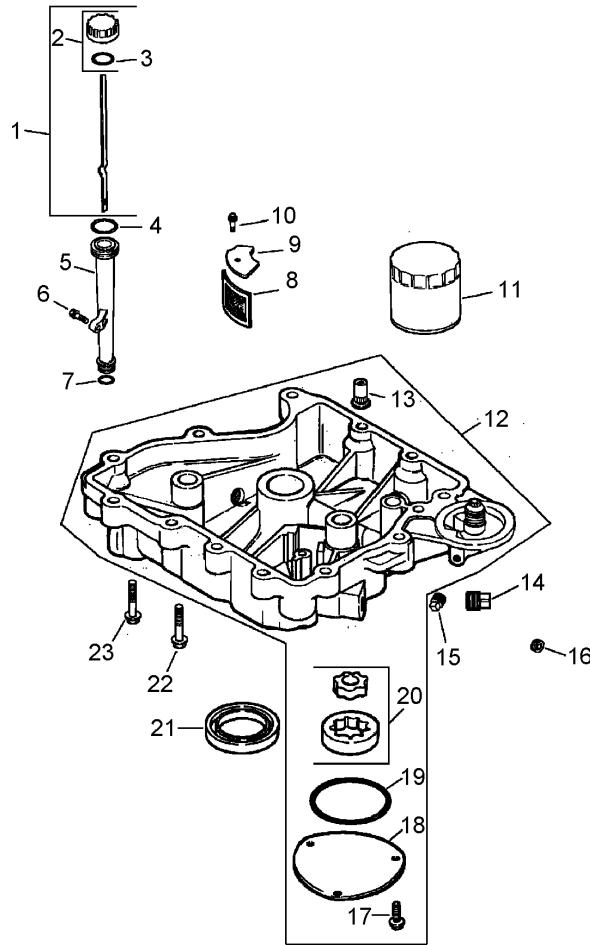

Oil Pan/Lubrication Assembly Kohler CV15T-41629

Ref	Part No.	Qty.	Description
❶	12 038 01-S	1	Dipstick ASM (Includes 2-3)
❷	25 755 13-S	1	Oil Fill Cap ASM (Includes 3)
❸	25 153 02-S	1	O-Ring
❹	12 153 02-S	1	O-Ring (Upper Oil Fill Tube)
❺	12 123 04-S	1	Tube-Fill, Oil
❻	M-545020-S	1	Screw-HF (M5x0.8x20)
❼	12 153 01-S	1	O-Ring (Lower Oil Fill Tube)
❽	25 162 07-S	1	Screen-Pickup, Oil
❾	12 096 03-S	1	Cover-Screen, Oil Pickup
❿	M-545016-S	1	Screw-HF (M5x0.8x16)
⓫	12 050 01-S	1	Filter-Oil
⓬	12 199 50-S	1	Oil Pan ASM (Includes 13, 17-19)
⓭	25 462 09-S	1	Valve-Relief, Oil Pressure
⓮	25 139 57-S	2	Plug-SQH (3/8in Nptf)
⓯	25 139 52-S	1	Plug-Pipe (1/8in)
⓰	25 139 62-S	1	Plug, Pipe 3/8in Hex Ctsk
⓱	M-545016-S	3	Screw-HF (M5x0.8x16)
⓲	12 096 34-S	1	Cover-Pump, Oil
⓳	12 153 06-S	1	O-Ring (Oil Pump Cover)
⓴	12 393 01-S	1	Oil Pump ASM
⓵	12 032 03-S	1	Seal-Oil, Front
⓶	24 086 16-S	10	Screw-HF (M8x1.25x45)
⓷	24 086 17-S	1	Screw-HF (M8x1.25x45)

--	--	--	--

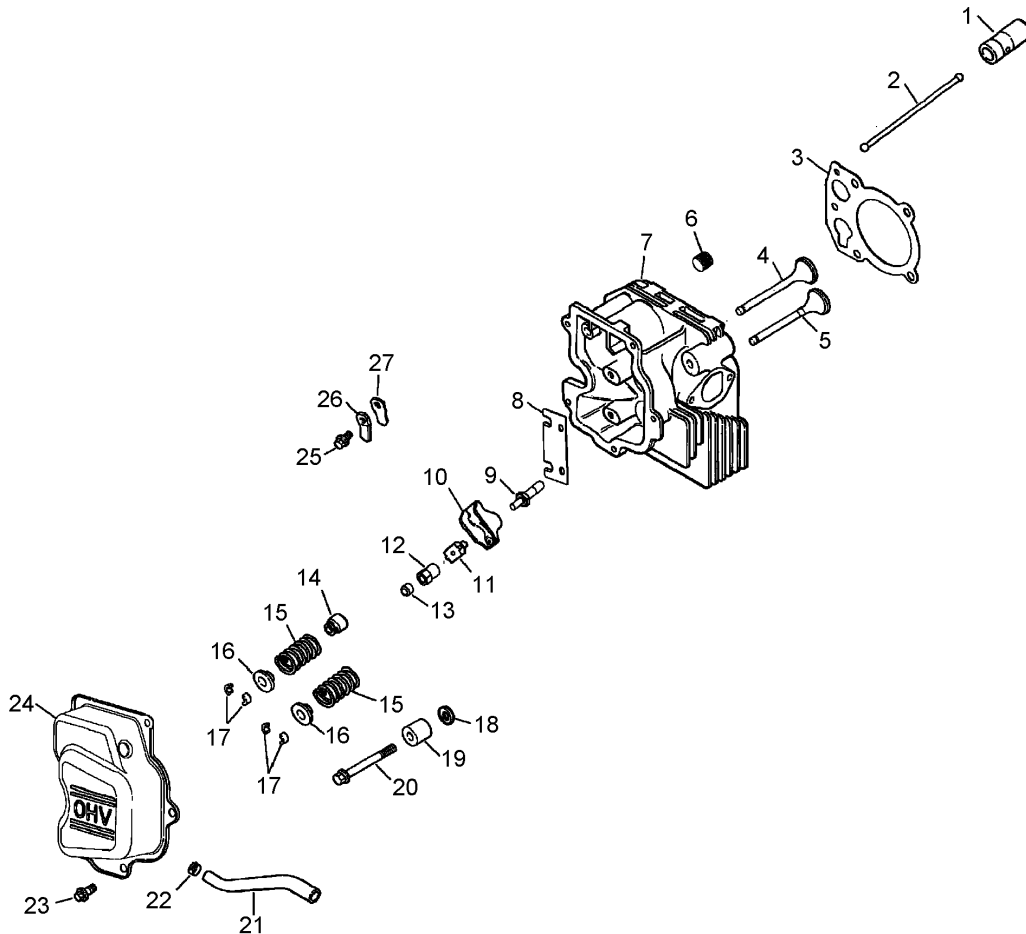

Head/Valve/Breather Assembly Kohler CV15T-41629

Ref	Part No.	Qty.	Description
❶	25 351 01-S	2	Lifter-Valve
❷	12 411 04-S	2	Rod-Push
❸	12 041 10-S	1	Gasket-Head, Cylinder
❹	12 017 01-S	1	Valve-Intake (Std.)
❺	12 016 01-S	1	Valve-Exhaust (Std.)
❻	25 139 60-S	1	Plug-Pipe, 1/8in Allen Head
❼	12 318 19-S	1	Head-Cylinder
❽	12 146 22-S	2	Plate-Guide
❾	25 072 12-S	2	Stud-Rocker
❿	25 186 01-S	2	Arm-Rocker
⓫	12 599 03-S	2	Pivot-Arm, Rocker
⓬	25 100 29-S	2	Nut-Hex
⓭	25 086 112-S	2	Screw-Set
⓮	66 032 05-S	2	Seal-Stem, Valve
⓯	12 089 34-S	2	Spring-Valve
⓰	12 173 01-S	2	Cap-Spring, Valve
⓱	12 755 03-S	2	Retainer Kit
⓲	12 468 05-S	1	Washer-Plain (13/32in)
⓳	12 112 13-S	1	Spacer-Head Bolt, Exhaust Port
⓴	20 086 02-S	5	Screw-HF (M10x1.5x81)
⓵	25 237 14-S	1	Clamp
⓶	12 326 18-S	1	Hose-Breather
⓷	M-645016-S	3	Screw-HF (M6x1.0x16)
⓸	12 096 47-S	1	Cover-Valve

Ref	Part No.	Qty.	Description
❷❹	M-545010-S	1	Screw-HF (M5x0.8x10)
❷❺	66 018 04-S	1	Retainer-Reed, Breather
❷❻	12 402 02-S	1	Reed-Breather
❶❶	12 017 02-S	1	Valve-Intake (.25)
❶❷	12 016 02-S	1	Valve-Exhaust (.25)
❶❸	12 041 01-S	1	Gasket-Carburetor
❶❹	12 041 02-S	1	Gasket-Base, Air Cleaner
❶❺	12 041 03-S	1	Gasket-Manifold, Exhaust

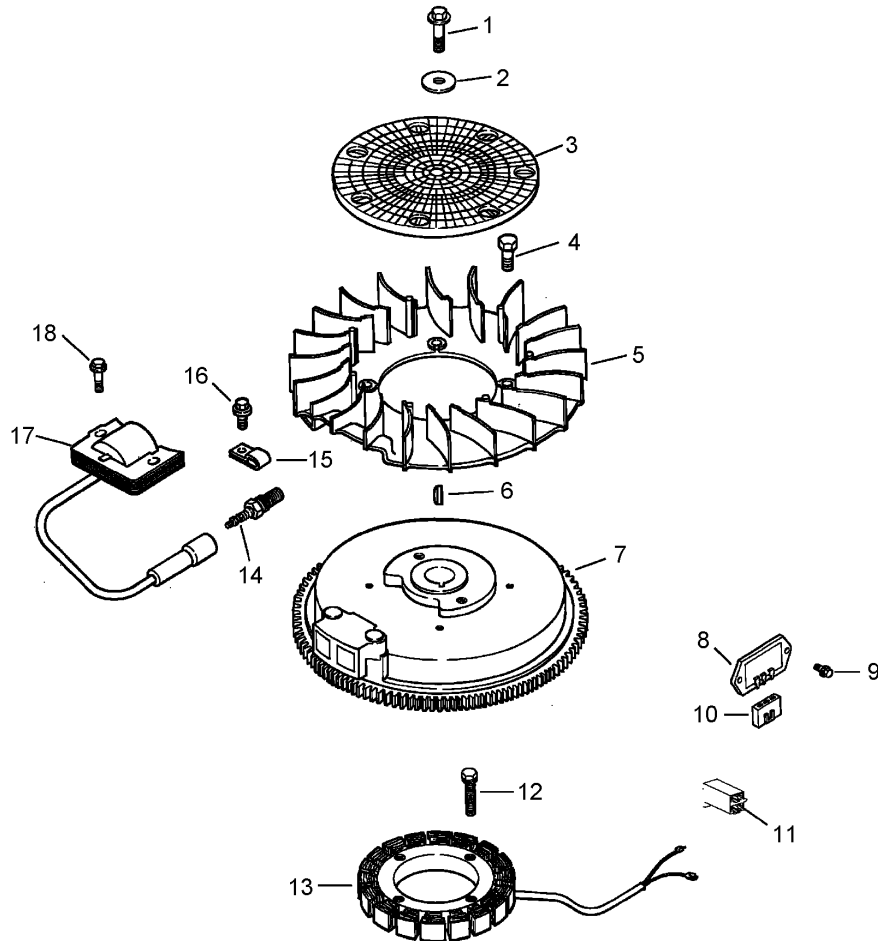

Ignition/Electrical Assembly Kohler CV15T-41629

Ref	Part No.	Qty.	Description
1	12 086 14-S	1	Screw-HF (M10x1.5x46)
2	12 468 03-S	1	Washer-Plain (3/8in)
3	24 162 03-S	1	Screen-Grass
4	25 086 47-S	4	Bolt-Shoulder (M6x1.0x16)
5	12 157 03-S	1	Fan
6	X-42-15-S	1	Key
7	12 025 56-S	1	Flywheel
8	12 403 01-S	1	Rectifier-Regulator
9	M-639016-S	2	Screw-HF (M6x1.0x16)
10	236602-S	1	Connector
11	41 155 03-S	1	Connector-Contact, Two
12	M-548025-S	2	Screw (M5x0.8x25)
13	237878-S	1	Stator Kit (Includes 25 452 01-S)
14	12 132 02-S	1	Spark Plug
15	X-728-1-S	2	Clip
16	M-545010-S	2	Screw-HF (M5x0.8x10)
17	12 584 05-S	1	Module-Ignition
18	M-545020-S	2	Screw-HF (M5x0.8x20)
19	X-22-11-S	1	Washer-Lock (1/4in)
20	12 518 01-S	1	Lead-White, Ground To Kill (19in, 18 Gauge)
21	25 518 05-S	1	Lead-Black, Rectifier To Connector
22	24 518 12-S	1	Lead-Black (5in, 12 Gauge)

Ref	Part No.	Qty.	Description
23	25 452 01-S	1	Terminal

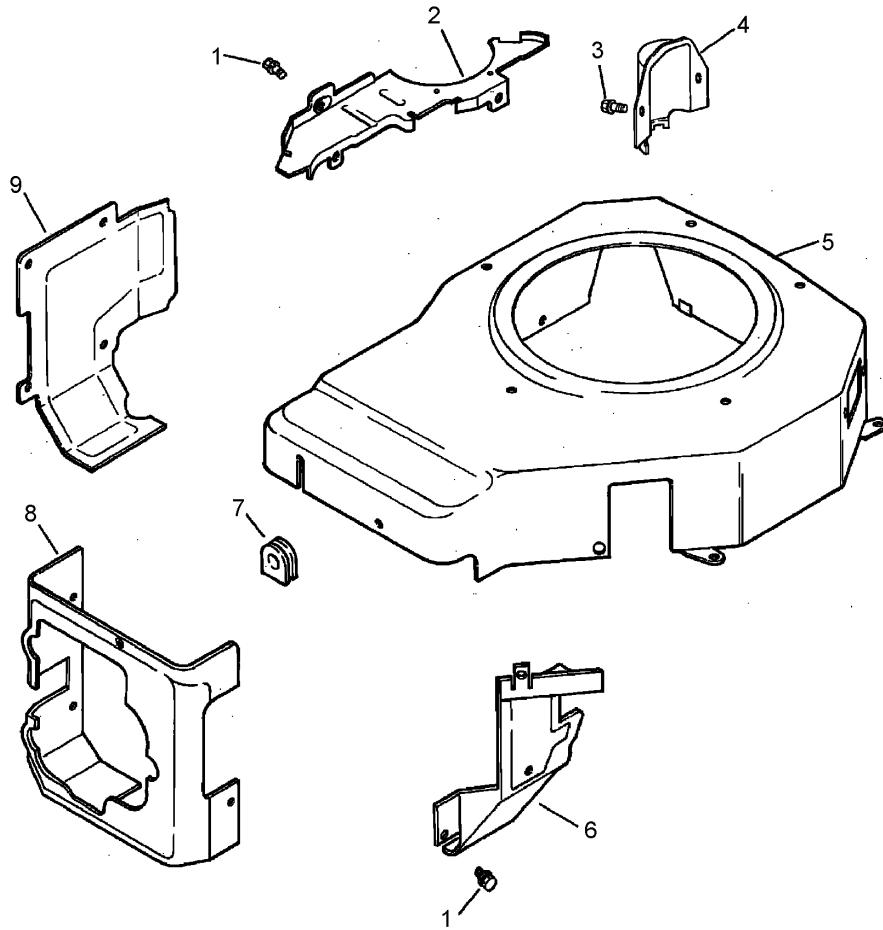

Blower Housing and Baffle Assembly Kohler CV15T-41629

Ref	Part No.	Qty.	Description				
1	M-545010-S	9	Screw-HF (M5x0.8x10)				
2	12 146 07-S	1	Plate-Housing, Blower				
3	M-550010-S	6	Screw-HF (M5x0.8x10)				
4	12 096 29-S	1	Cover-Starter				
5	12 027 68-S	1	Housing, Blower				
6	12 063 10-S	1	Baffle-Side, Intake				
7	12 313 03-S	1	Grommet-Spark Plug				
8	12 063 08-S	1	Baffle-Head, Cylinder				
9	12 063 19-S	1	Baffle (Cylinder)				
10	12 113 124-S	1	Decal-15hp				
11	25 113 39-S	1	Decal-Lamination, Clear				

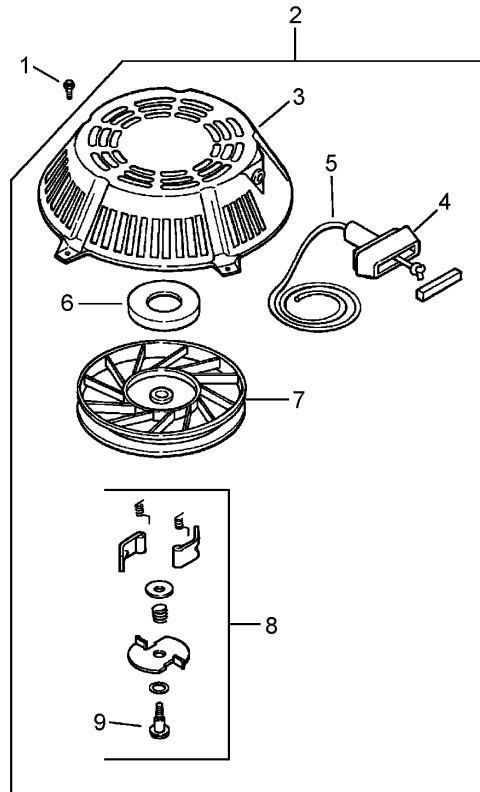

Starting System Assembly Kohler CV15T-41629

Ref	Part No.	Qty.	Description				
①	M-550010-S	5	Screw-HF (M5x0.8x10)				
②	12 165 01-S	1	Retractable Starter ASM (Includes 3-9)				
③	12 081 01-S	1	Housing-Starter				
④	25 166 01-S	1	Handle-Start, Recoil				
⑤	12 160 01-S	1	Rope-Starter				
⑥	12 089 06-S	1	Spring And Keeper				
⑦	12 093 01-S	1	Pulley				
⑧	12 757 06-S	1	Dog Repair Kit				
⑨	41 086 09-S	1	Screw-Pozidriv				
⑩	15 109 01-S	1	Cup, Drive				
⑪	12 113 07-S	1	Decal-Starting				

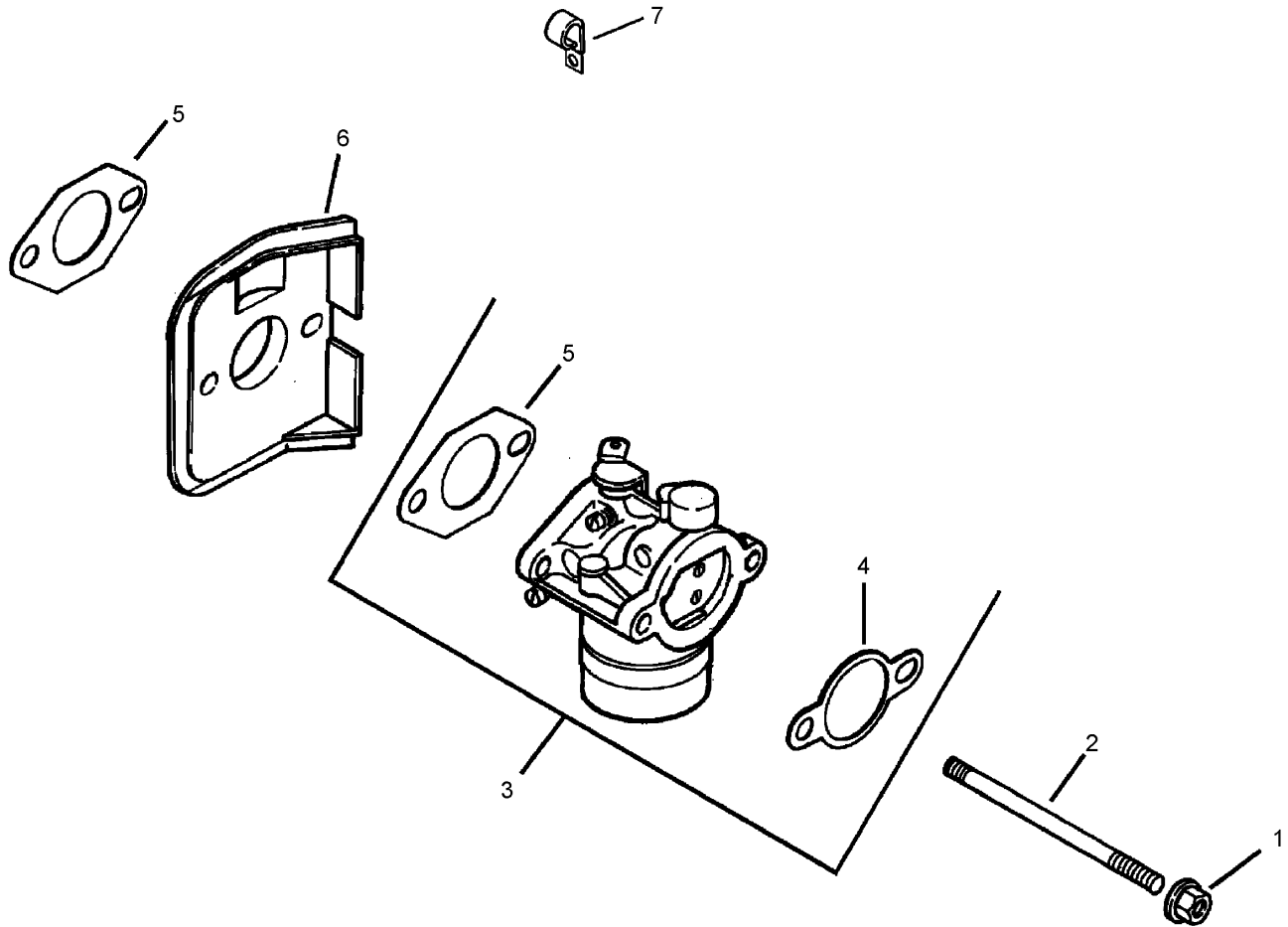

Fuel System Assembly Kohler CV15T-41629

Ref	Part No.	Qty.	Description
1	M-641060-S	2	Nut-HF
2	M-629116-S	2	Stud (M6x1.0x116)
3	12 853 140-S	1	Carburetor Kit (Includes 4-5)
4	12 041 02-S	1	Gasket-Base, Air Cleaner
5	12 041 01-S	2	Gasket-Carburetor
6	12 265 04-S	1	Deflector-Heat
7	47 154 01-S	1	Clip-Cable
1	12 757 02-S	1	Float Kit
1	12 757 03-S	1	Carburetor Repair Kit
1	12 757 08-S	1	Choke Repair Kit
1	12 757 36-S	1	Throttle Shaft Bearing Kit
1	12 757 37-S	1	Bowl Replacement Kit
1	12 755 92-S	1	High Altitude Kit

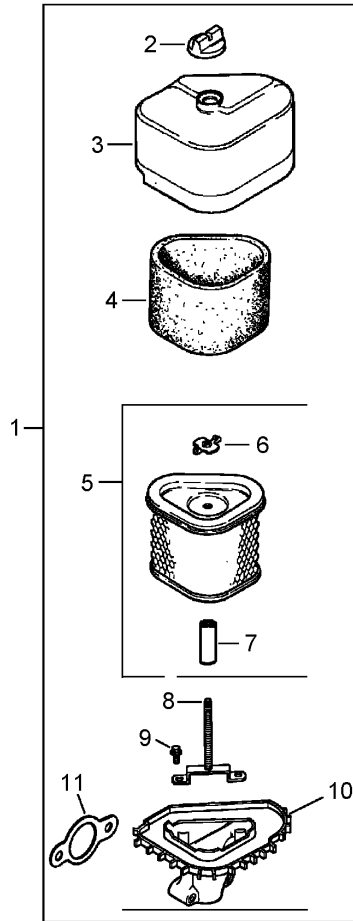

Air Intake/Filtration Assembly Kohler CV15T-41629

Ref	Part No.	Qty.	Description				
❶	12 743 04-S	1	Air Cleaner Kit (Includes 2-11)				
❷	20 341 01-S	1	Knob-Cover				
❸	12 096 44-S	1	Cover-Cleaner, Air				
❹	12 083 12-S	1	Precleaner				
❺	12 083 10-S	1	Element-Cleaner, Air (Includes 6-7)				
❻	12 100 01-S	1	Nut-Wing				
❼	12 032 11-S	1	Seal				
❽	12 072 04-S	1	Stud-Plate, Mounting				
❾	12 086 01-S	2	Screw				
❿	12 094 14-S	1	Base-Cleaner, Air				
⓫	12 041 02-S	1	Gasket-Base, Air Cleaner				
⓬	12 113 04-S	1	Decal-Cleaner, Air				

Attachments and Accessories

For 30433 - Mid-Size ProLine Pistol Grip Hydro, 15 HP with 36in Side Discharge Mower

Product Name	Model/Part
Blade-Atomic	104-1301
Electric Starter Kit	104-8580
36 Inch Recycler Kit	105-3180
Weight Kit	106-5491
Soft Bag (3 Bushel)	30104
Steel Grass Catcher	30107
Tru Trak Sulky	30110
Blade	56-2390-03
Blade-Mulch	99-8549

NOTES

NOTES

NOTES

