



Spray System Workman® 200

Model No. 41229 - 240000001 and up.

Parts Catalog

Ordering Replacement Parts

To order replacement parts, please supply: the part number, the quantity, and the description of each part desired.

Understanding Reference Numbers

Each identified part in an illustration has a reference number. The reference number for a part also appears in the parts list, along with other information about the part.

This catalog uses two special reference number formats, one to indicate parts in a service assembly and another to indicate the quantity of a given part in an illustration.

Service Assembly Reference Numbers

Parts in service assemblies have reference numbers in the form **a:b**. The **a** represents the reference number of the entire service assembly and the **b** represents a sequential number unique to each part within the service assembly.

For example, a wheel assembly might be identified by reference number 6, the tire by **6:1**, the valve by **6:2**, and the wheel by **6:3**. When you order the assembly identified by reference number 6, you receive all parts identified by reference numbers 6:1, 6:2, and 6:3. However, you may also order any part individually. Reference numbers of this type appear in illustrations and in part lists.

Reference Numbers Indicating Quantity

In an illustration, if a reference number indicates more than one part, the reference number has the form **nX y**. The **n** represents the quantity of the part, the **X** is the multiplication symbol, and the **y** represents the reference number.

For example, in an illustration, the reference number **2X 37** means that two of the parts identified by reference number 37 are indicated.

Part Description Abbreviations

Part descriptions in this catalog may include the following abbreviations.

AR.	as required	HYD.	hydraulic
ASM.	assembly	INC.	incorporated
CARR.	carriage	LH.	left hand
DEG.	degrees	NI.	nylon insert
FH.	flat head	PPH.	phillips pan head
GA.	gauge	PTH.	phillips truss head
HF.	hex flange	PTO.	power take off
HH.	hex head	RH.	right hand
HHF.	hex head flange	SFH.	slotted fillister head
HHFTF.	hex head flange thread forming	SHH.	slotted hex head
HJ.	hex jam	SHWH.	slotted hex washer head
HLH.	hex lag head	SPH.	slotted pan head
HOC.	height-of-cut	SQH.	square head
HS.	hex	SRH.	slotted round head
HSBH.	hex socket button head	STD.	standard
HSFH.	hex socket flat head	TAP.	self tapping
HS.	hex socket head	TTH.	torx truss head
HWH.	hex washer head	WH.	wing head
HWHTF.	hex washer head thread forming		

Footnotes

- ❶ Not illustrated
- ❷ Not serviced separately

Contents

Description	Page	Description	Page
Skid and Frame Assembly 3	Top Mounted Suction Assembly No. 107-2800 17
Fresh Water Tank Assembly 4	Lower Sprayer Components Assembly 18
Fresh Water Tank Assembly No. 100-8438 5	Safety Valve Assembly No. 100-6820 19
Tank and Cover Assembly 6	Control Assembly 20
200 Gallon Tank Assembly No. 106-1366 7	EVC Control Valve Assembly 21
Strainer and Seal Assembly 8	Control Box Assembly 23
Lid Assembly 9	Hose Assembly 24
Pump and Drive Assembly 10	Electrical Harness Assembly 26
Pump Assembly No. 106-5121 11		
Drive Shaft Assembly No. 107-2810 12		
Upper Sprayer Components Assembly 13		
Suction and Drain Assembly 14		
Tank Drain Assembly 15		
Upper Tank Drain Bulkhead Assembly 16		

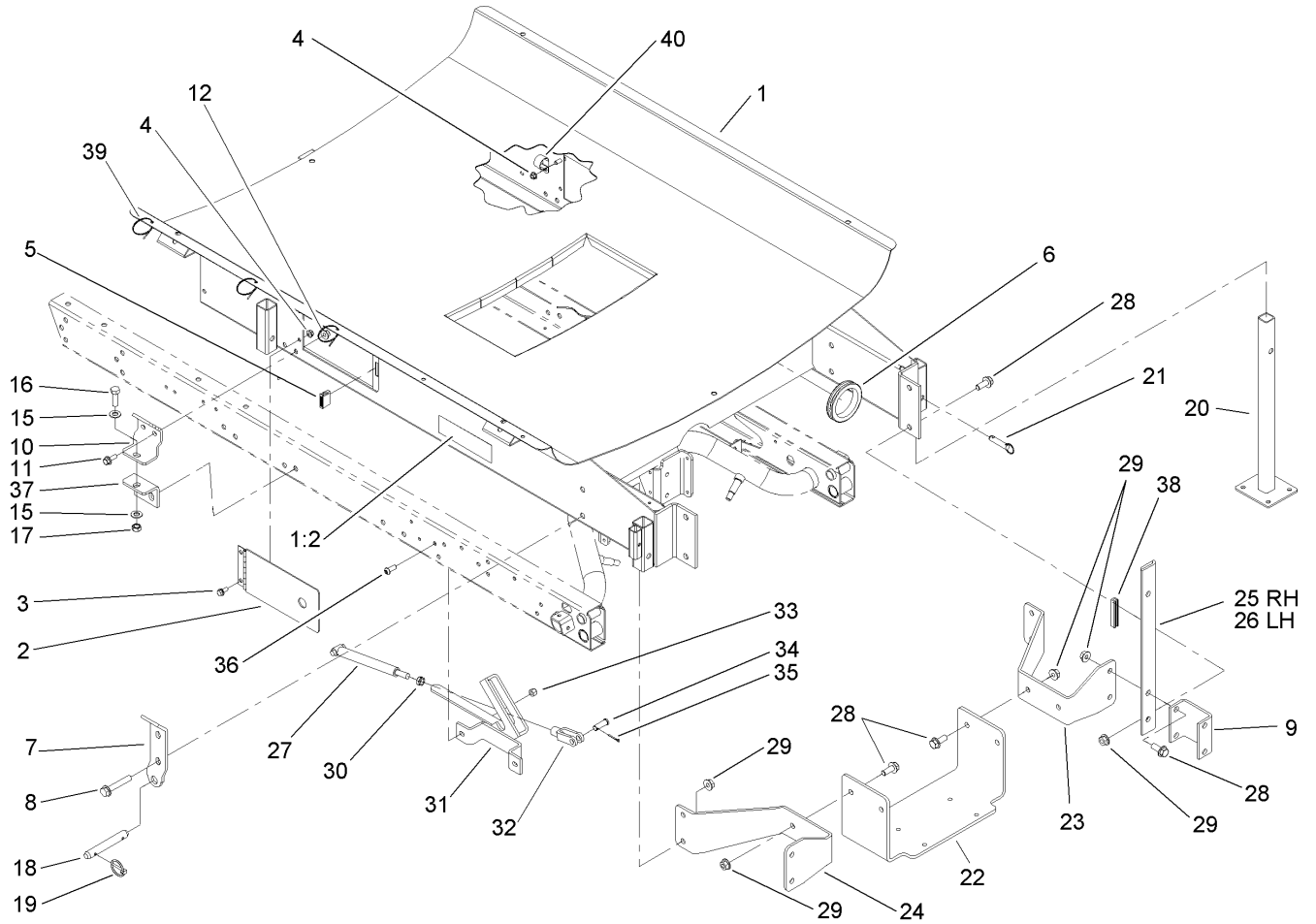

Skid and Frame Assembly

Ref	Part No.	Qty.	Description
1	106-1367	1	Skid ASM
1:2	106-1365	1	Decal-Danger
2	106-1290-03	2	Door ASM
3	3234-5	4	Screw
4	32128-20	4	Nut-HF
5	92-3700	2	Magnet-Door
6	237-102	3	Grommet
7	107-2858	2	Lug-Pivot
8	3234-40	4	Screw-HF
9	92-8533-03	2	Bracket-Mounting, Boom
10	107-2859	2	Bracket-Mount, Front
11	3234-42	4	Screw-HHF
12	32128-43	4	Nut-Flange
15	3256-26	4	Washer-Flat
16	325-6	2	Screw-HH
17	32153-5	2	Nut-Lock
18	92-1233	2	Pin-Clevis
19	92-1298	4	Pin-Lynch
20	105-9482-03	4	Jack Stand ASM
21	100-4523	4	Pin-Hitch
22	106-1345-03	1	Base-Pump
23	107-2829-03	1	Bracket-Pump, RH
24	107-2828-03	1	Bracket-Pump, LH
25	106-7987-03	1	Angle-Boom Mount, RH

Ref	Part No.	Qty.	Description
26	106-7986-03	1	Angle-Boom Mount ,lh
27	106-2503	1	Prop Rod ASM
28	3234-32	12	Screw-HHF
29	32128-49	16	Nut-HHF
30	3220-5	1	Nut-Jam
31	106-2491-03	1	Strut Support Bracket ASM
32	100-7338	1	Yoke-RH
33	3296-39	2	Nut-Lock, NI
34	104-3634	1	Pin-Clevis
35	3272-11	1	Pin-Cotter
36	3274-94	2	Screw-HSBH
37	92-2667-03	2	Bracket-Attachment, Mount
38	70-2041	1	Trim
39	3290-381	3	Tie-Cable
40	2412-126	1	R-Clamp

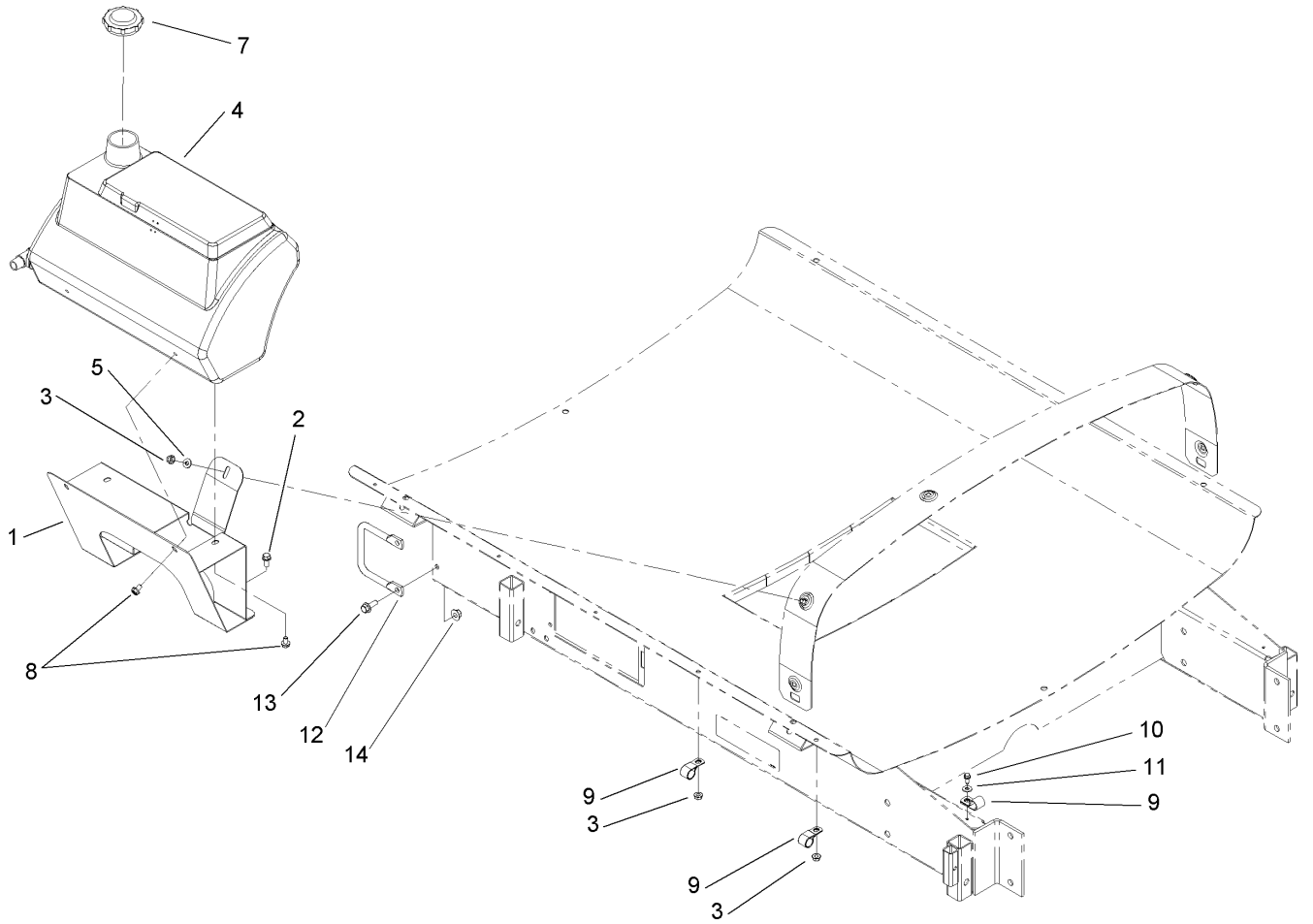

Fresh Water Tank Assembly

Ref	Part No.	Qty.	Description
1	107-2819-03	1	Fresh Water Tank Bracket ASM
2	3234-5	2	Screw
3	32128-20	3	Nut-HF
4	100-8438	1	Fresh Water Tank ASM
5	3256-56	1	Washer-Flat
7	100-7008	1	Cap-Tank, Fresh Water
8	3234-28	4	Screw-HHF
9	2412-4	3	Clamp
10	32144-10	1	Screw-HWH
11	3256-2	1	Washer-Flat
12	106-1357	2	Handle
13	3234-42	4	Screw-HHF
14	32128-43	4	Nut-Flange

--	--	--	--

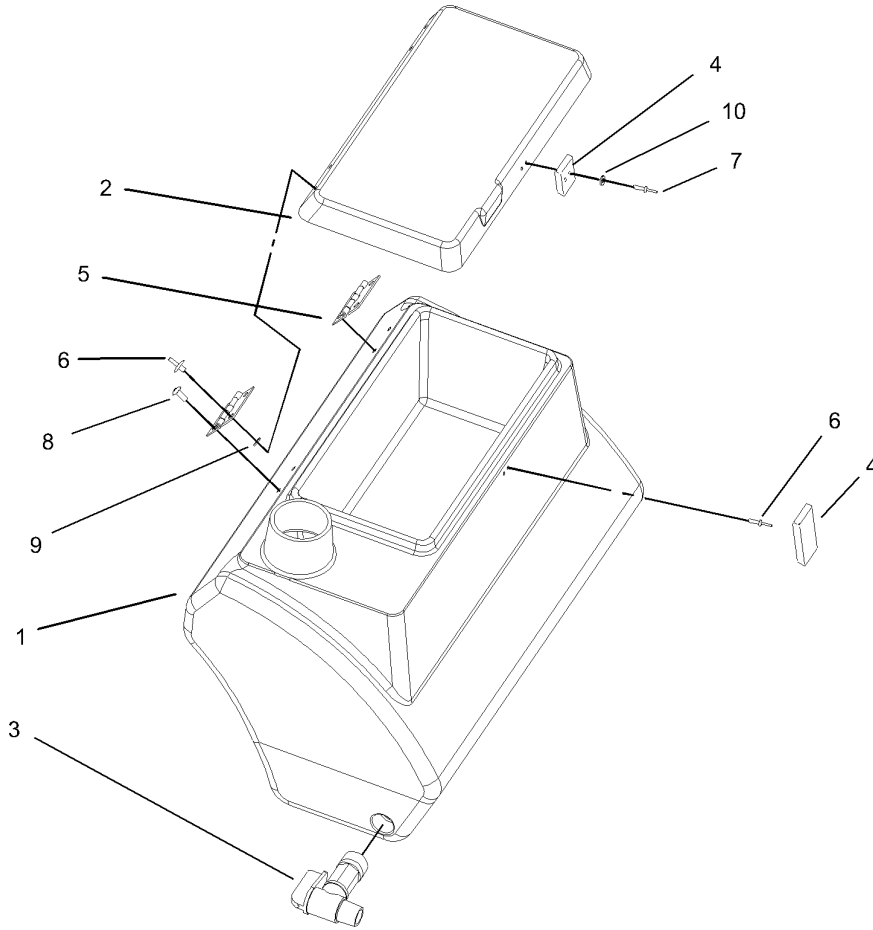

Fresh Water Tank Assembly No. 100-8438

Ref	Part No.	Qty.	Description
1		1	Tank-Water, Fresh
2	100-8397	1	Cover-Tank
3	100-7011	1	Spigot-90 DEG
4	100-7009	1	Latch-Draw
5	100-7010	2	Hinge
6	100-7062	4	Rivet
7	100-7063	4	Rivet
8	100-7064	4	Screw
9	100-7065	4	Washer
10	100-7066	2	Washer

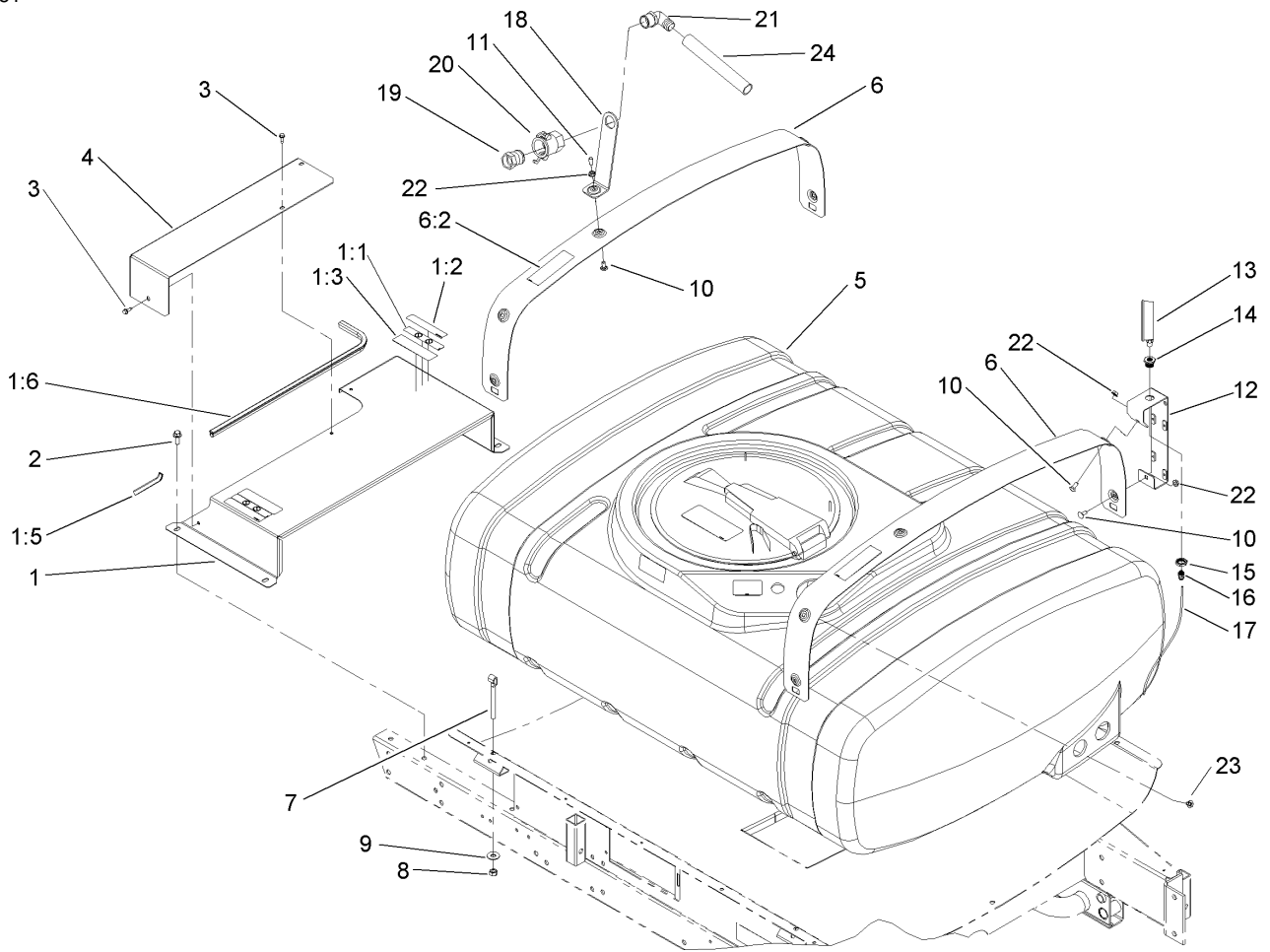

Tank and Cover Assembly

Ref	Part No.	Qty.	Description
1		1	Radiator Cover ASM W/ Decals
1:1	93-6687	2	Decal-No Step
1:2	93-6689	2	Decal-No Riders
1:3	93-7814	2	Decal-Danger
1:5	92-3627	1	Trim
1:6	42657	1	Trim-Panel, Front
2	3234-42	4	Screw-HHF
3	32104-95	3	Screw-HWH
4	93-6427-03	1	Panel-Radiator
5	106-1366	1	200 Gallon Tank ASM
6	106-1368	2	Band-Tank
6:2	106-5016	1	Decal-Caution, Electric Shock (Ce)
7	92-3668	4	Bolt-J
8	3217-8	4	Nut-Hex
9	3256-5	4	Washer-Flat
10	3230-1	3	Bolt-CARR
11	42452	1	Cap-Protective
12	106-7997-03	1	Tee Mounting Bracket ASM
13	104-8949	1	Gauge-Pressure
14	100-8665	1	Reducer-Gauge, Pressure
15	100-8666	1	Nut-Reducer
16	100-8667	1	Coupler-Reducer
17	107-2834	1	Tubing-Pressure
18	100-6778-03	1	Bracket-Anti-Siphon

Ref	Part No.	Qty.	Description
19	41316	1	Adapter-Quick
20	100-6779	1	Coupling-Female
21	41140	1	Elbow
22	32128-20	3	Nut-HF
23	3230-19	1	Screw-CARR
24	104-9075	1	Hose-Siphon, Anti

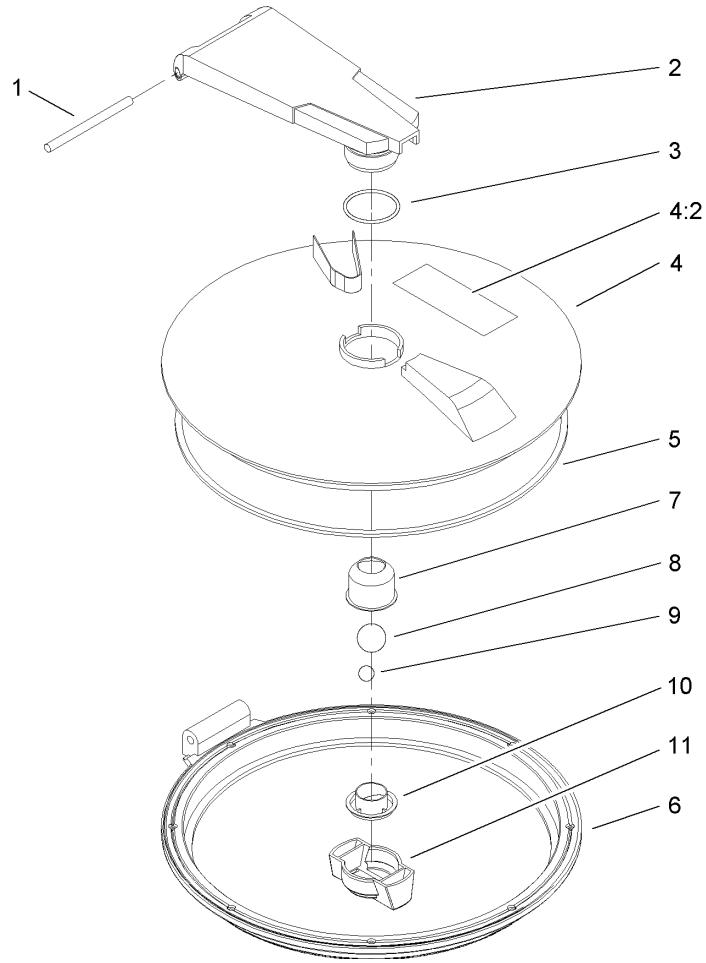

Lid Assembly

Ref	Part No.	Qty.	Description				
1	106-5000	1	Pin-Pivot				
2	106-5001	1	Arm				
3	106-5002	1	O-Ring				
4	106-1369	1	Lid				
4:2	93-0688	1	Decal-Warning, Chemical				
5	106-5004	1	Seal-Lid				
6	106-5005	1	Ring				
7	106-5006	1	Cup-Vent				
8	106-5007	1	Ball-Floating				
9	106-5008	1	Ball-Weight				
10	106-5009	1	Holder-Ball				
11	106-5010	1	Nut-Wing				

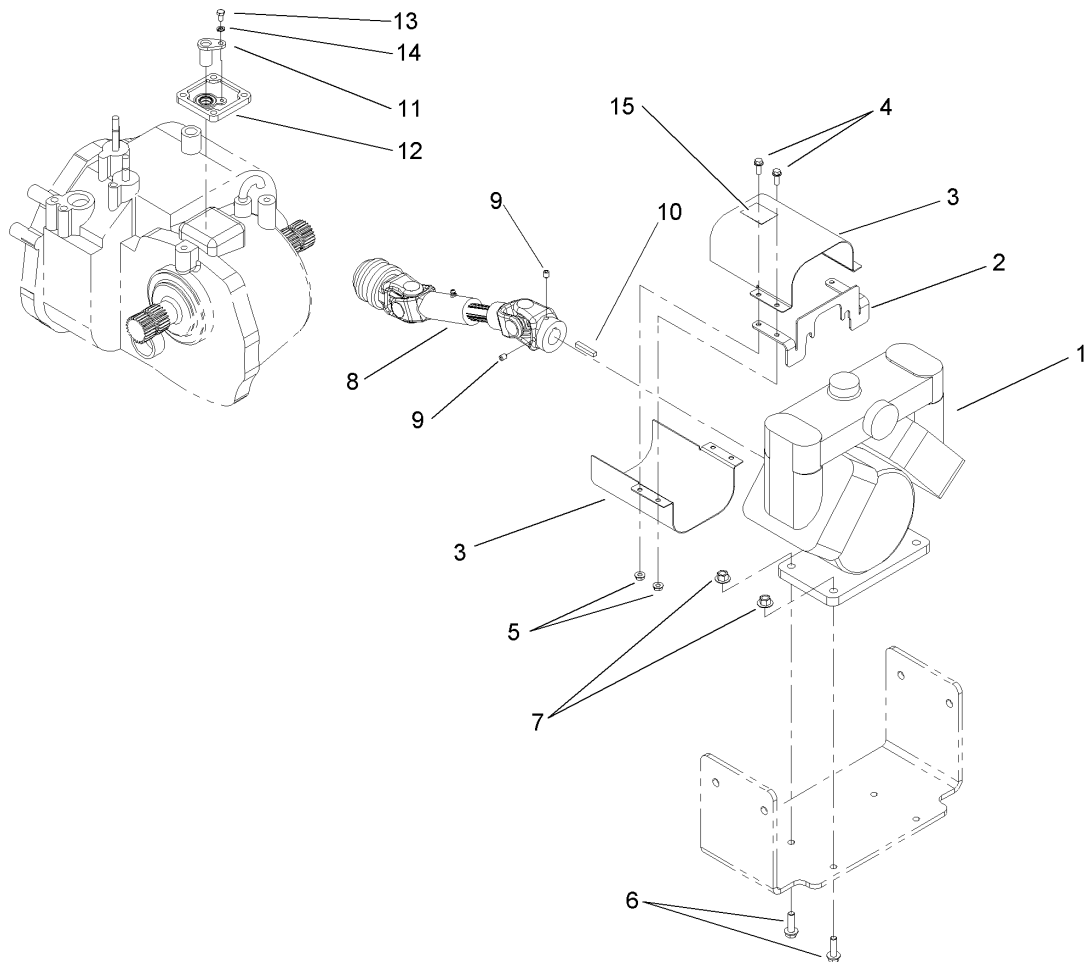

Pump and Drive Assembly

Ref	Part No.	Qty.	Description
1	106-5121	1	Pump
2	104-8970-03	1	Bracket-Shroud
3	104-8971-03	2	Shroud-Drive, Pump
4	3234-4	4	Screw-HHF
5	32128-33	4	Nut-HF
6	3234-24	4	Screw-HHF
7	32128-43	4	Nut-Flange
8	107-2810	1	Shaft-Drive, PTO
9	3246-18	2	Setscrew
10	67-7490	1	Key-Square
11	85-4350	1	Sensor-Gear tooth
12	92-3736	1	Cover ASM
13	33113-012	1	Screw-HH
14	48-8020	1	Washer-Spring
15	106-1354	1	Decal-540 Rpm

--	--	--	--

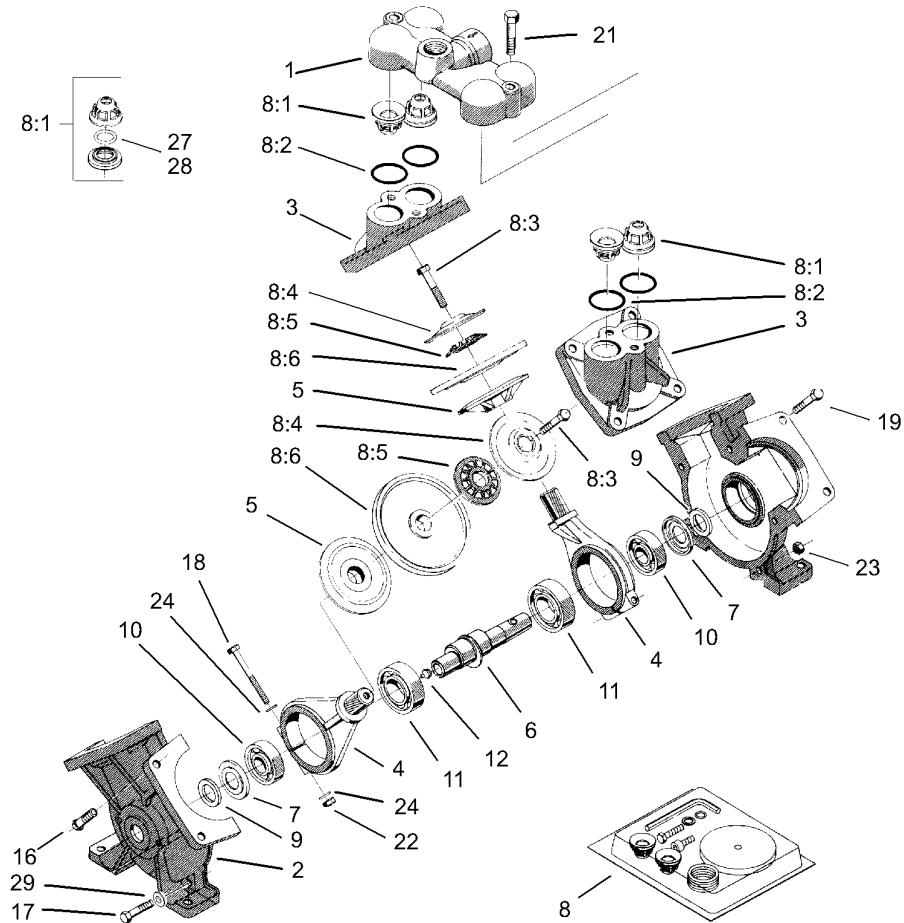

Pump Assembly No. 106-5121

Ref	Part No.	Qty.	Description
1	106-5139	1	Cover-Valve
2	106-5140	2	Housing-Pump
3	106-5141	2	Cover-Diaphragm
4	106-5142	2	Rod-Connecting
5	100-8314	2	Disc-Back, Diaphragm
6	104-9052	1	Crankshaft-Keyed
7	100-8325	2	Plate-Dust
8	106-5150	1	Repair Kit
8:1	100-8307	4	Valve
8:2	100-6652	4	Gasket
8:3	106-5147	2	Bolt
8:4	100-8311	2	Washer
8:5	100-8312	2	Washer-Nylon
8:6	100-8313	2	Diaphragm
9	99-0868	2	Felt-Seal
10	100-8327	2	Bearing-Ball
11	100-8329	2	Bearing-Ball
12	99-0873	1	Fitting-Grease
16	106-5143	3	Bolt
17	106-5144	2	Bolt
18	106-5145	2	Bolt
19	106-5146	8	Bolt
21	106-5148	2	Bolt
22	100-8326	2	Nut-Hex

Ref	Part No.	Qty.	Description
23	106-5149	5	Nut
24	100-8316	4	Washer-Lock
27	100-8336	4	O-Ring
28	106-5138	4	O-Ring
29	106-5137	2	Washer

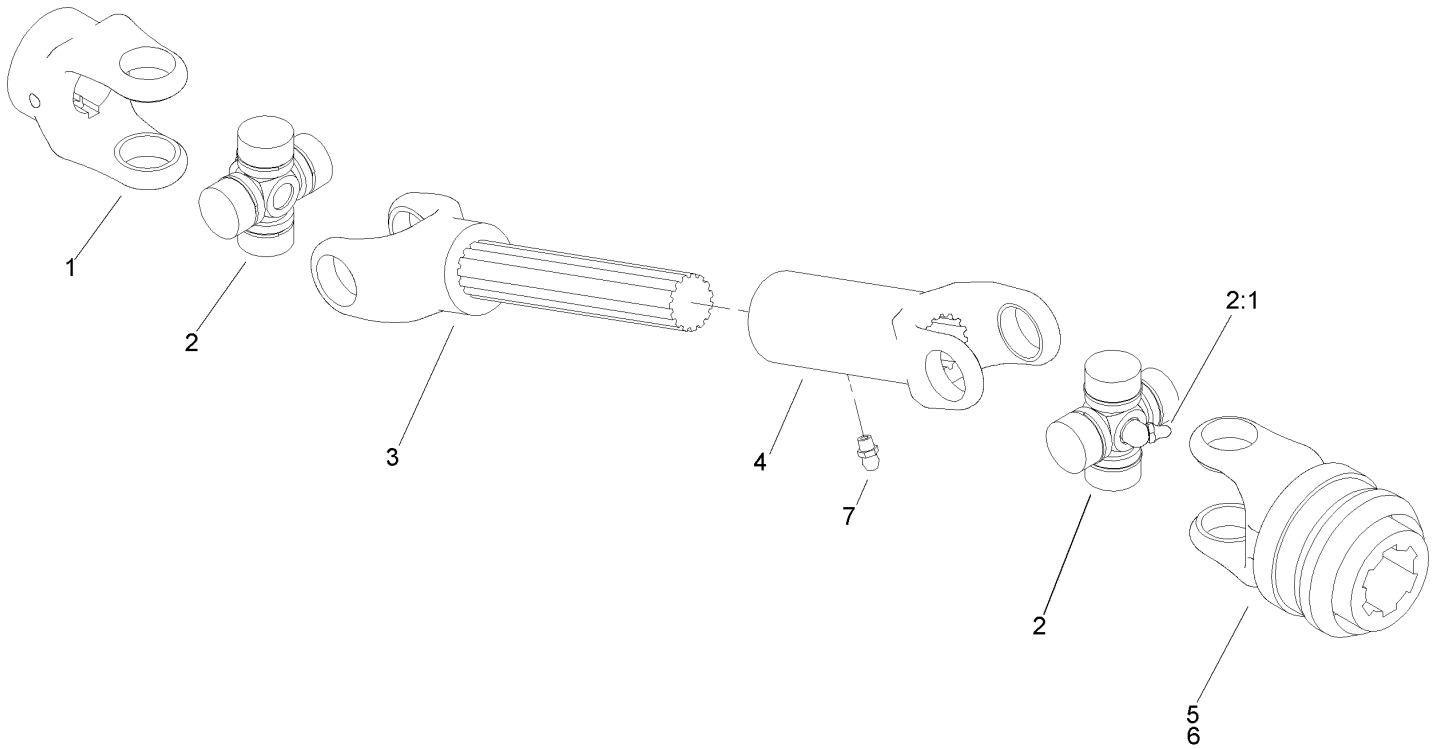

Drive Shaft Assembly No. 107-2810

Ref	Part No.	Qty.	Description
1	107-2823	1	Yoke-Shaft
2	54-9180	2	U-Joint Kit
2:1	62-3820	1	Fitting-Grease
3	107-2824	1	Shaft-Yoke, Slip
4	94-7379	1	Tube-Yoke, Slip
5	99-4476	1	Spring-Lok Yoke ASM
6	99-4477	1	Spring-Lok Repair Kit
7	302-5	1	Fitting-Grease

--	--	--	--

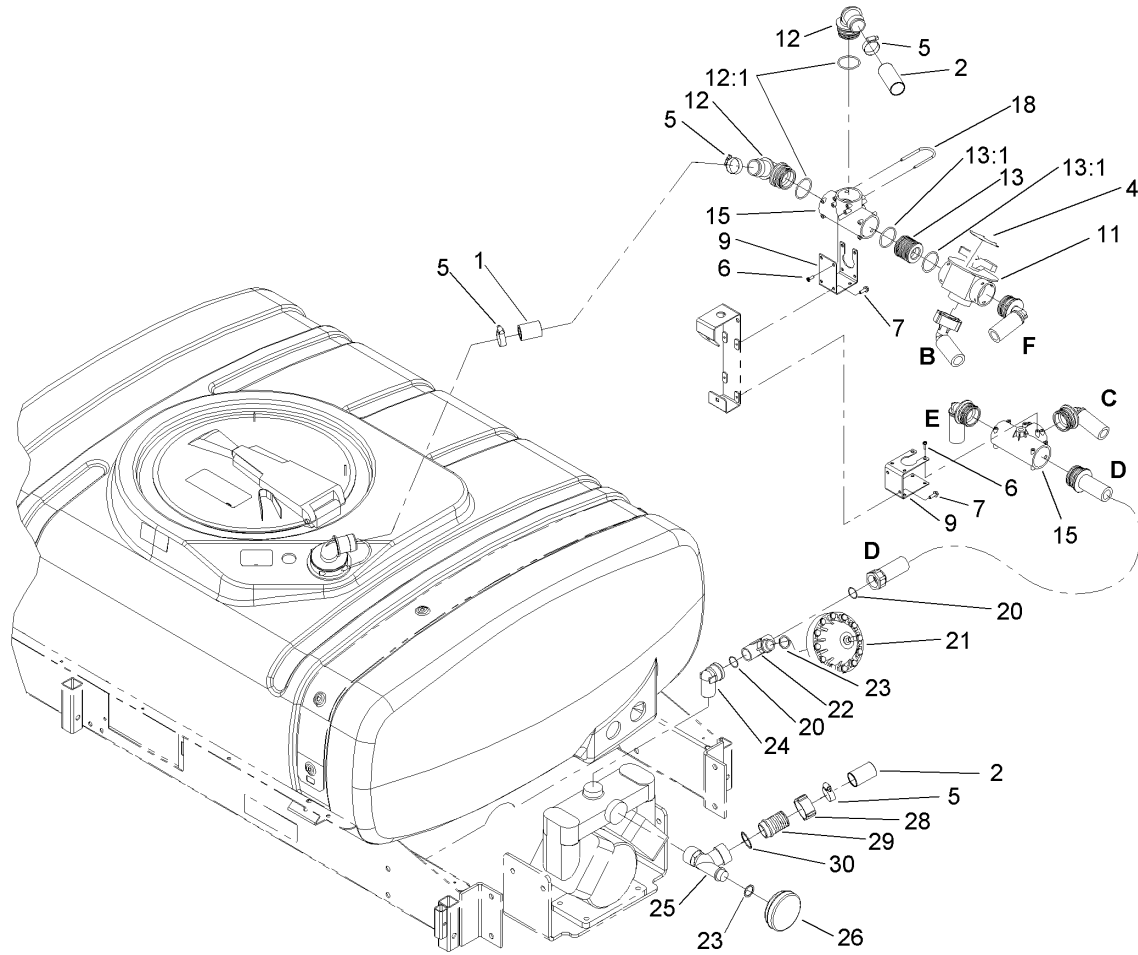

Upper Sprayer Components Assembly

Ref	Part No.	Qty.	Description
1	107-2804	1	Hose-Suction
2	107-2805	1	Hose-Suction
4	100-8577	1	Decal-Agitate Valve
5	41327	4	Clamp-Hose
6	32144-32	8	Screw
7	3234-4	4	Screw-HHF
9	100-8478	2	Bracket-Tee
11	100-8673	1	Agitation Valve ASM
12	106-4946	2	Hosebarb-90 DEG
12:1	100-8637	1	O-Ring
13	106-4947	1	Connector
13:1	100-8637	2	O-Ring
15	100-6704	2	Tee
18	100-8635	8	Fork
20	100-6655	2	Gasket
21	100-6662	1	Damper-Pressure
22	100-8699	1	Tee
23	100-6656	2	O-Ring
24	100-8698	1	Elbow
25	100-8681	1	Tee
26	100-6660	1	Suction Damper ASM
28	100-8678	1	Nut
29	100-8679	1	Hosebarb
30	100-8680	1	Seal

Ref	Part No.	Qty.	Description
31	3334-945	3	Tie-Cable

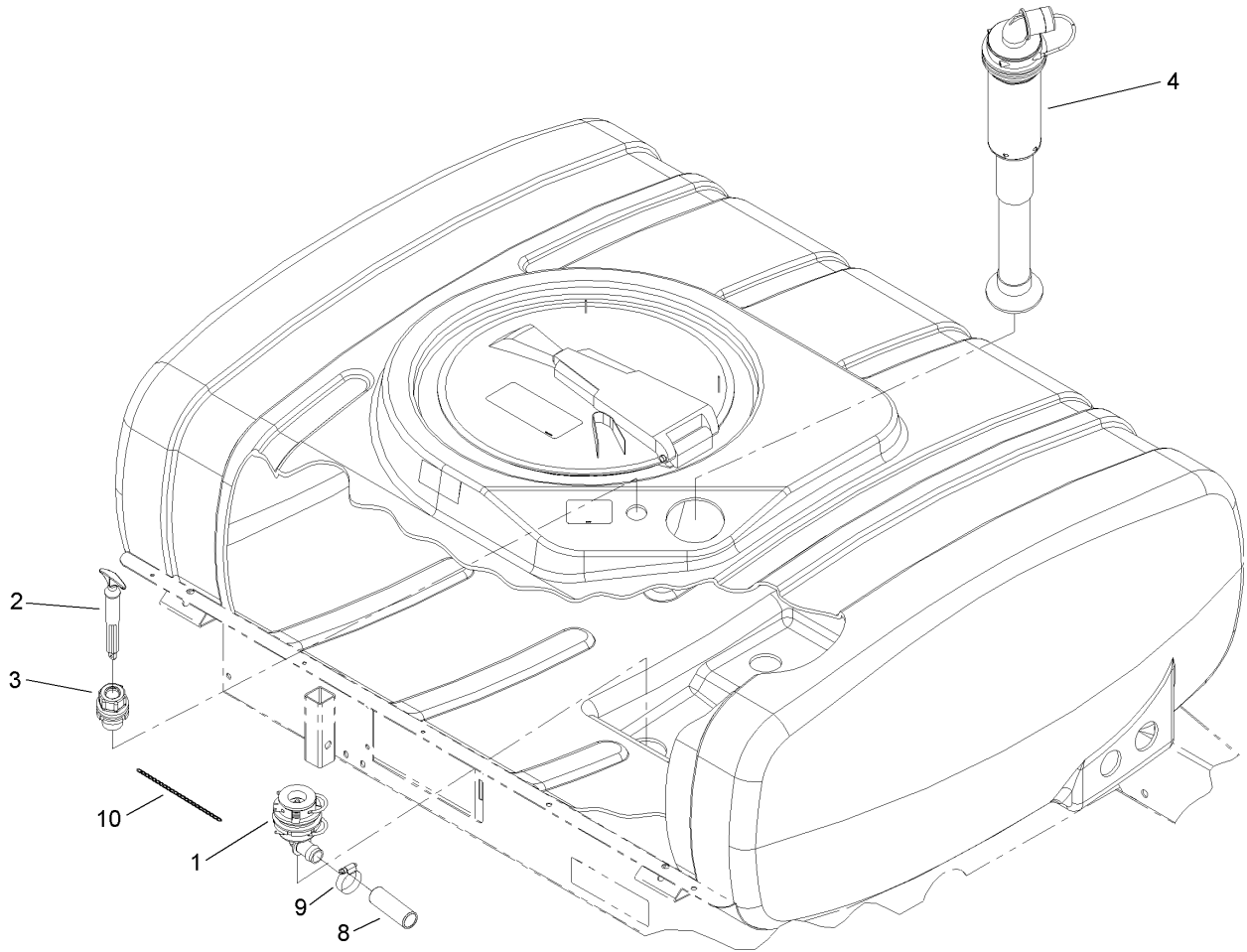

Suction and Drain Assembly

Ref	Part No.	Qty.	Description				
1		1	Drain ASM				
2	106-1347	1	Handle-Drain				
3		1	Upper Tank Drain Bulkhead ASM				
4	107-2800	1	Top Mounted Suction ASM				
8	106-1351	1	Hose-Drain				
9	2412-3	1	Clamp-Hose				
10	106-1356	1	Chain ASM (19")				

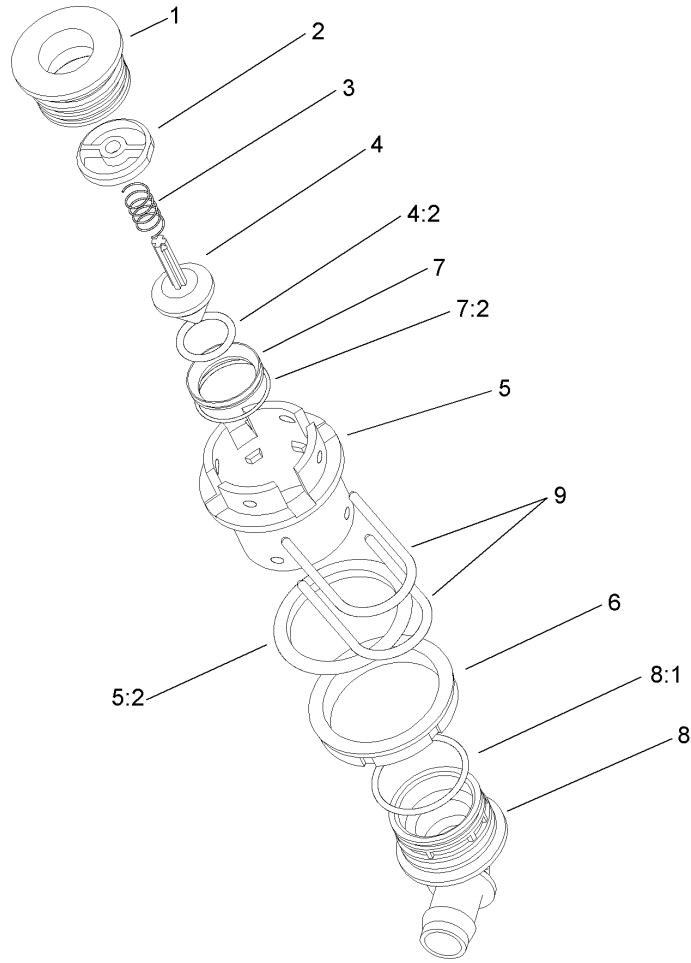

Tank Drain Assembly

Ref	Part No.	Qty.	Description				
1	107-2868	1	Adapter				
2	107-2869	1	Holder-Plunger				
3	107-2871	1	Spring				
4	107-2870	1	Plunger ASM-Drain				
4:2	107-2872	1	O-Ring				
5	107-2862	1	Drain Bulkhead ASM (S67)				
5:2	107-2864	1	Gasket-Bulkhead (S67)				
6	100-7051	1	Nut-Bulkhead, (S67)				
7	107-2867	1	Seat Drain ASM				
7:2	107-2866	1	O-Ring				
8	106-4933	1	Hosebarb ASM				
8:1	100-8637	1	O-Ring				
9	100-8635	2	Fork				

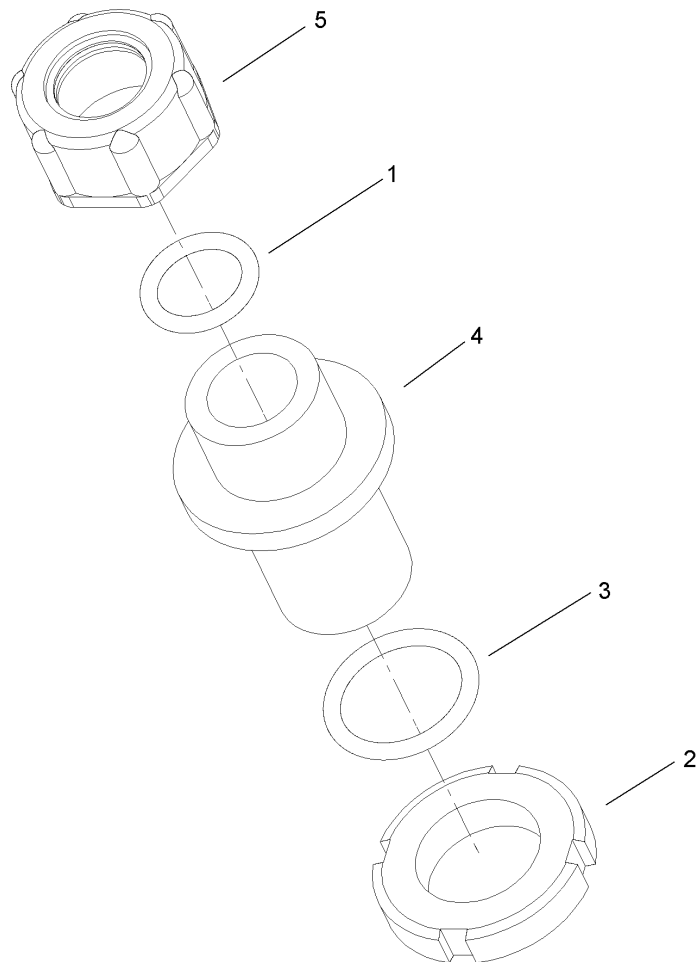

Upper Tank Drain Bulkhead Assembly

Ref	Part No.	Qty.	Description				
1	100-6643	1	O-Ring				
2	99-0758	1	Nut				
3	100-6658	1	Gasket				
4	106-1240	1	Bulkhead				
5	106-1241	1	Nut-Special				

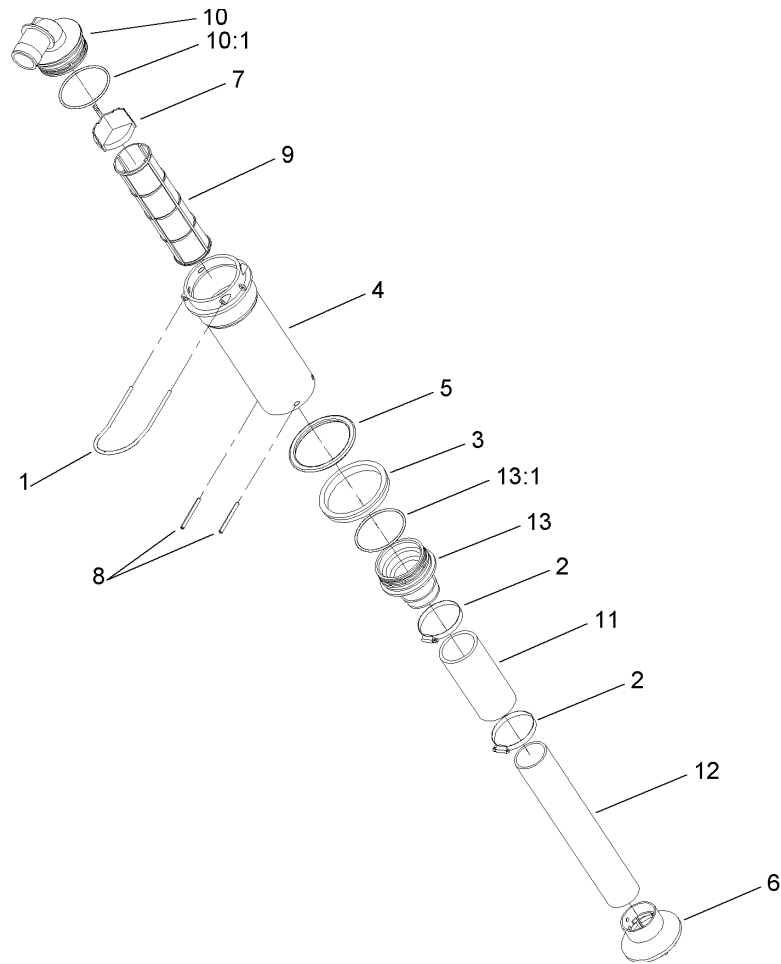

Top Mounted Suction Assembly No. 107-2800

Ref	Part No.	Qty.	Description
1	100-8636	1	Fork-Special
2	26392	2	Clamp-Hose
3	100-8647	1	Nut-Bulkhead
4	100-8643	1	Housing-Filter
5	100-8646	1	Gasket-Bulkhead
6	100-6714	1	Foot-Suction Tube
7	100-8641	1	Vane-Screen
8	100-8644	2	Pin-Expansion
9	100-8642	1	Screen-Suction, Mesh 50
10	106-4952	1	Hosebarb-90 DEG
10:1	100-6989	1	O-Ring
11	100-8649	1	Hose-Suction
12	107-2801	1	Tube-Suction
13	106-4942	1	Hosebarb-Straight
13:1	100-8640	1	O-Ring

--	--	--	--

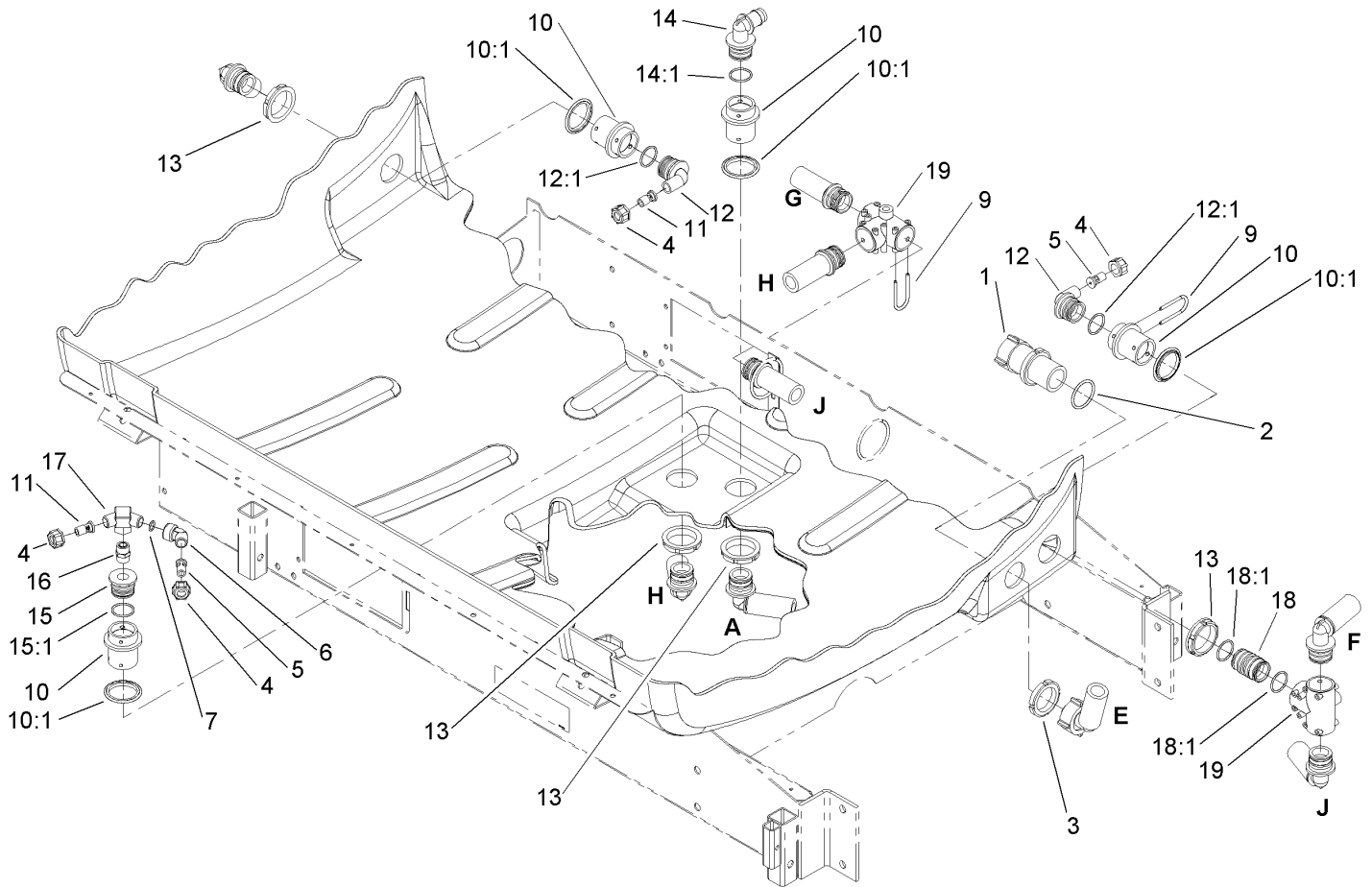

Lower Sprayer Components Assembly

Ref	Part No.	Qty.	Description
1	100-6820	1	Valve-Safety, 225 Psi
2	100-6652	1	Gasket
3	99-0761	1	Ringnut
4	99-0766	4	Nut
5	100-6705	2	Nozzle-Agitation
6	99-0768	1	Elbow-60 DEG
7	100-6653	1	O-Ring
9	100-6708	14	Fork
10	106-4896	4	Fitting-Bulkhead
10:1	100-6710	1	Gasket-Bulkhead
11	100-6706	2	Nozzle-Agitation
12	106-4944	2	Fitting-90 DEG
12:1	100-6712	1	O-Ring
13	100-6713	4	Nut-Bulkhead
14	106-4945	1	Elbow
14:1	100-6712	1	O-Ring
15	106-4943	1	Adapter ASM
15:1	100-6712	1	O-Ring
16	100-6722	1	Nipple
17	100-6723	1	Tee
18	107-2802	1	Connector (S53)
18:1	100-6712	2	O-Ring
19	104-9041	2	Tee

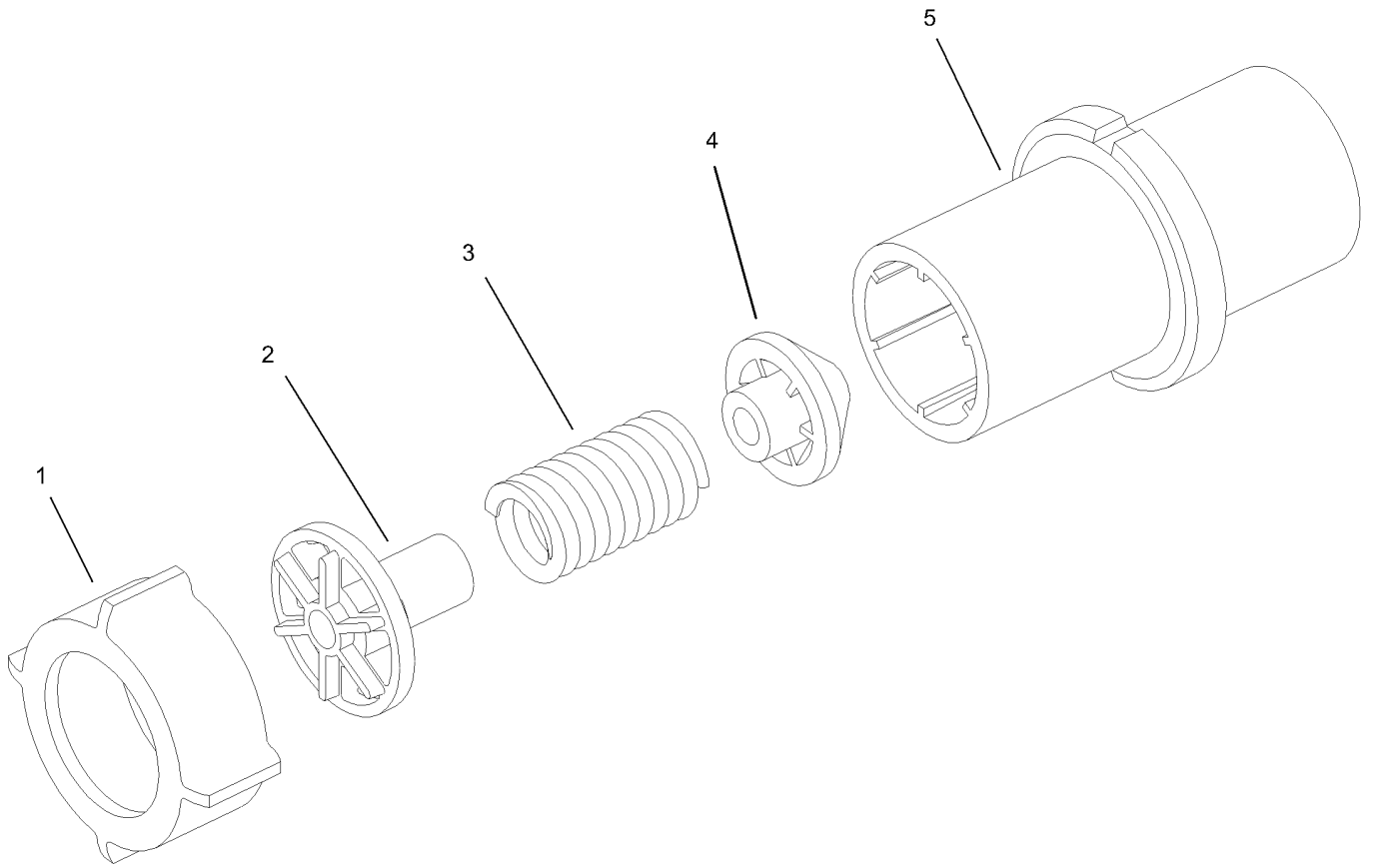

Safety Valve Assembly No. 100-6820

Ref	Part No.	Qty.	Description
1	100-8678	1	Nut
2	100-6724	1	Valve-Relief, Seat
3	100-6725	1	Spring-Relief Valve
4	100-6726	1	Cone-Relief Valve
5	100-6727	1	Housing-Relief Valve

--	--	--	--

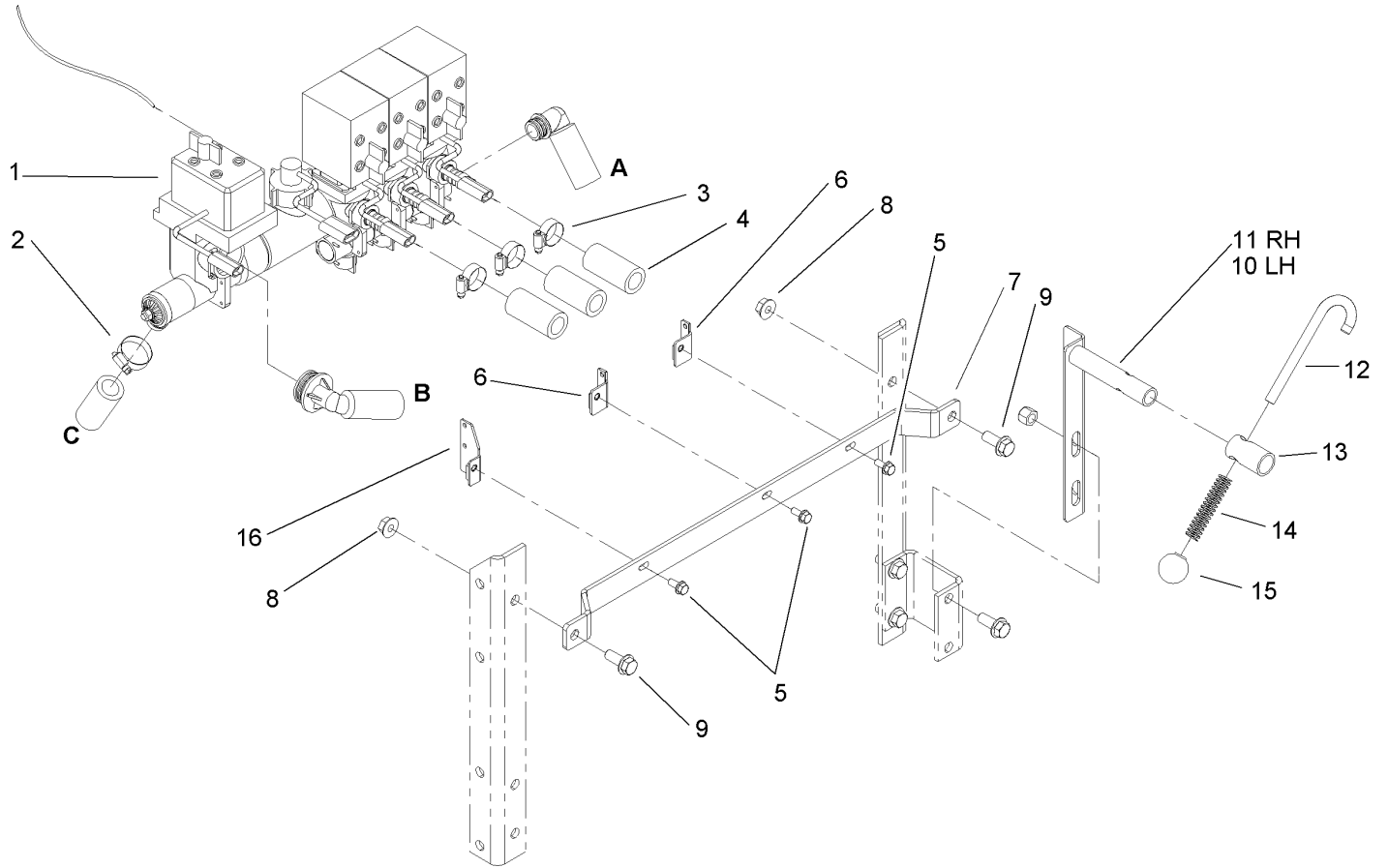

Control Assembly

Ref	Part No.	Qty.	Description
1		1	Valve-Control, Evc
2	2412-3	1	Clamp-Hose
3	2412-129	3	Clamp-Hose
4	41340	3	Hose-Boom, Left And Right
5	3234-5	3	Screw
6	100-8432-03	2	Bracket
7	107-2847-03	1	Bracket-Valve
8	32128-49	2	Nut-HHF
9	3234-32	2	Screw-HHF
10	107-2838-03	1	Holder-Tube, LH
11	107-2839-03	1	Holder-Boom, RH
12	92-8562	2	Hook-Restraint, Boom
13	107-2853	2	Hose-Hold In
14	92-8563	2	Spring
15	92-8564	2	Knob
16	100-8433-03	1	Bracket

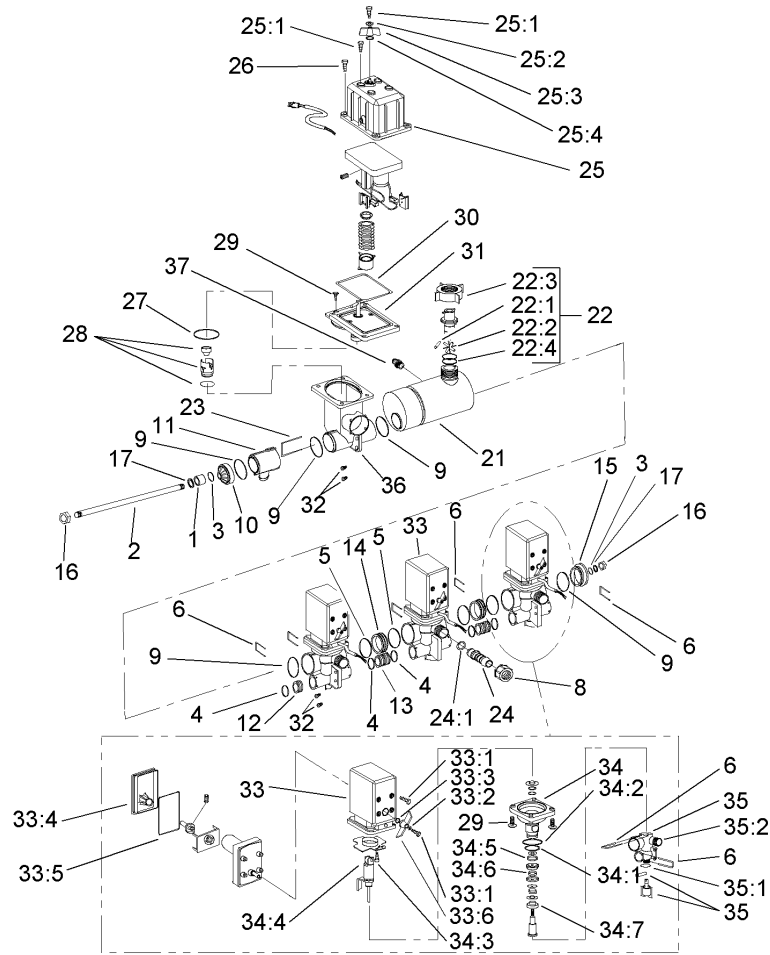

EVC Control Valve Assembly

Ref	Part No.	Qty.	Description
1	100-6897	1	Bushing
2	100-6909	1	Rod-Threaded
3	100-6887	2	O-Ring
4	100-6882	5	O-Ring
5	100-6646	5	O-Ring
6	100-6885	9	Fork-Valve, Boom
8	99-0850	3	Nut
9	100-6892	4	O-Ring
10	100-6913	1	Cover
11	100-6908	1	T-Piece
12	100-6891	1	Cap-End
13	100-6890	2	Joiner-Bypass, Boom
14	100-6896	2	Joiner-Valve, Boom
15	100-6915	1	Cover-End
16	100-6894	2	Nut
17	100-6634	2	Washer
21	100-6920	1	Housing-Meter, Flow
22	100-6900	1	Flow Sensor ASM
22:1	100-6906	1	Shaft-Rotor
22:2	100-6919	1	Meter-Flow, Rotor
22:3	100-8678	1	Nut
22:4	100-8653	1	O-Ring
23	100-6907	1	Fork
24	106-5112	3	Hosebarb ASM

Ref	Part No.	Qty.	Description
24:1	100-6645	1	O-Ring
25	106-1358	1	Rate Control Motor ASM
25:1	100-6876	1	Screw
25:2	100-6877	1	Washer-Lock
25:3	100-6903	1	Grip-Hand
25:4	100-6880	1	O-Ring
26	100-6918	4	Screw-Plastic
27	100-6904	1	O-Ring
28	100-6905	1	Rate Valve Repair Kit
29	100-6917	16	Screw-Plastic
30	100-6901	1	Gasket-Housing, Valve Motor
31	100-6899	1	Section-Spindle, Valve Rate
32	100-6916	6	Screw-Plastic
33	107-2861	3	Boom Valve Motor ASM
33:1	100-6876	3	Screw
33:2	100-6877	3	Washer-Lock
33:3	100-6880	3	O-Ring
33:4	100-6874	3	Cover-Valve, Boom
33:5	100-6912	3	Cover-Seal
33:6	100-6875	3	Handgrip-Valve, Boom
34	100-6889	3	Section-Spindle, Boom Valve
34:1	100-8653	1	O-Ring
34:2	100-6882	5	O-Ring
34:3	100-6911	1	Pin-Roller

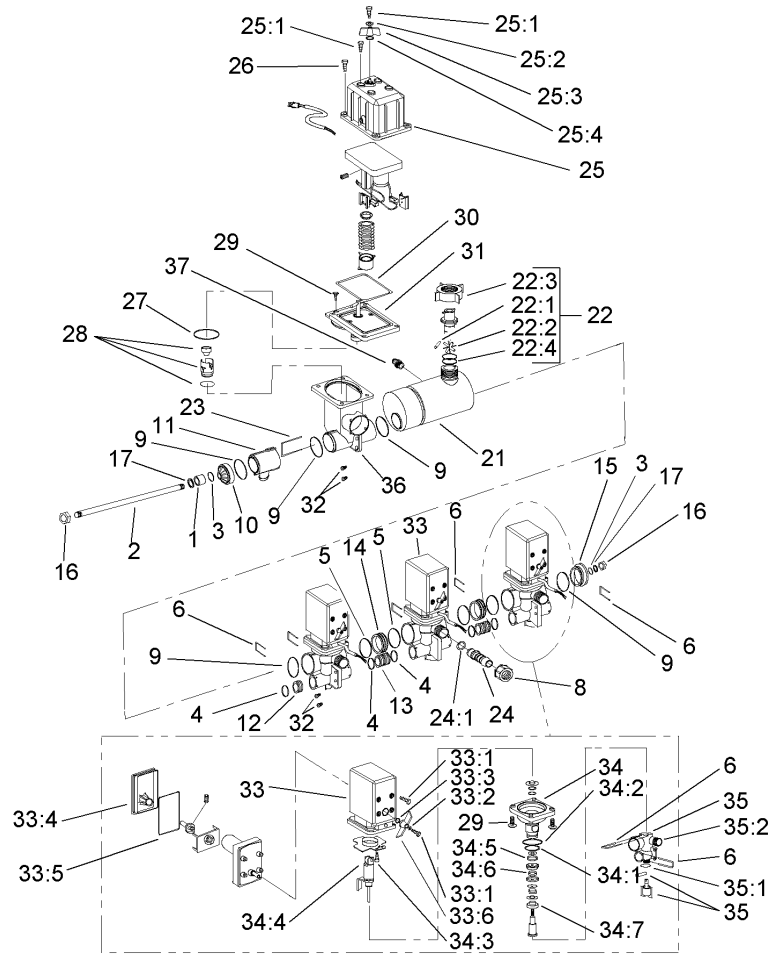

EVC Control Valve Assembly (continued)

Ref	Part No.	Qty.	Description				
34:4	100-6910	1	Bearing-Roller				
34:5	100-6879	1	O-Ring				
34:6	100-6878	1	O-Ring				
34:7	100-6881	1	Cone-Stem, Boom Valve				
35	100-6888	3	Manifold-Valve, Boom				
35:1	100-6887	1	O-Ring				
35:2	106-5151	1	Manifold-Lower				
36	100-6914	1	Valve-Control, Housing Rate				
37	100-8674	1	Coupler-Tube				

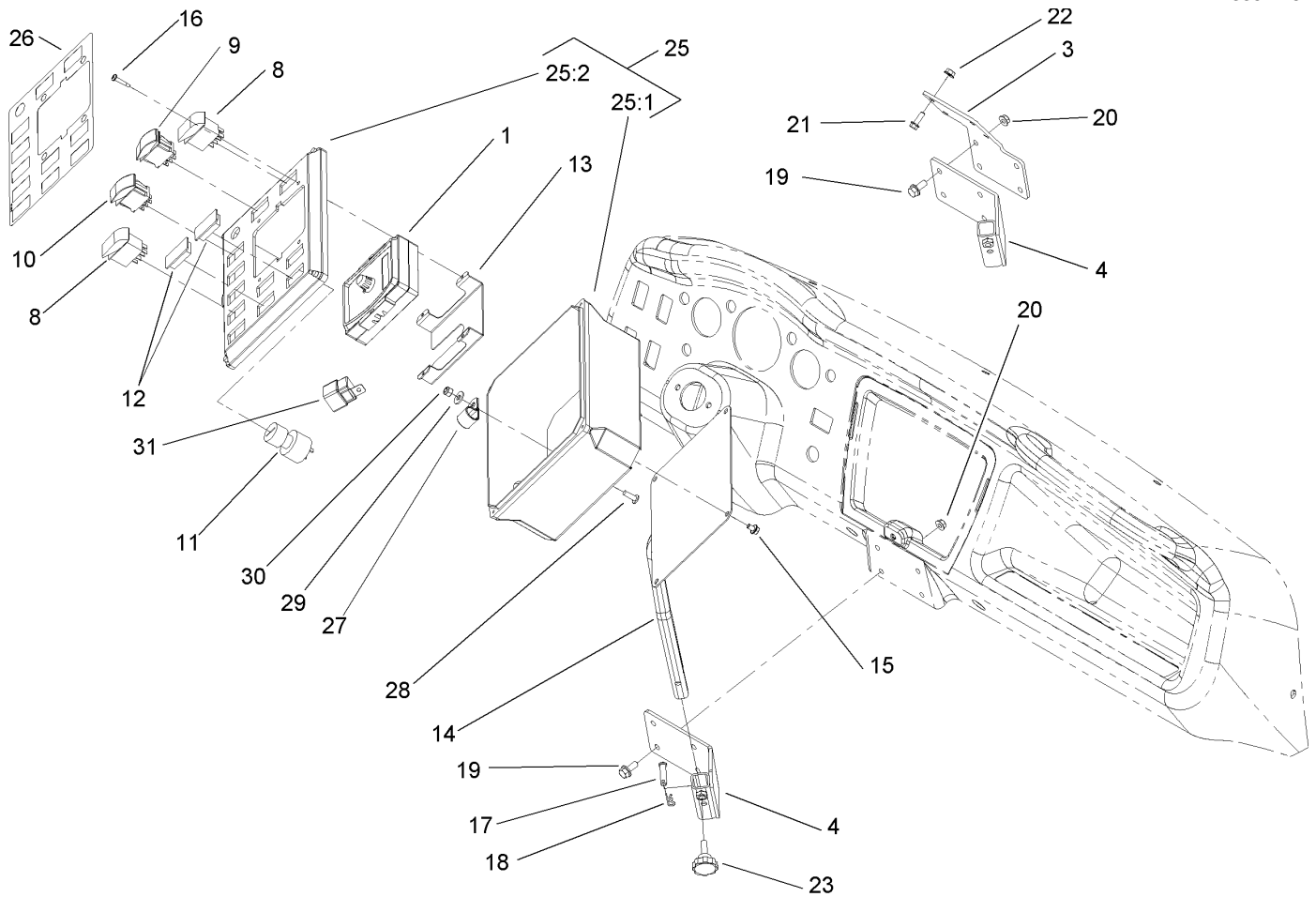

Control Box Assembly

Ref	Part No.	Qty.	Description
1	104-8991	1	Monitor-Spray
3	107-2811-03	1	Bracket-Adapter, Control
4	106-7992-03	1	Receiver ASM
8	100-8490	4	Switch-Dpdt
9	100-1535	1	Switch
10	100-8589	1	Switch-Rocker
11	94-5245	1	Switch-Key
12	99-7420	5	Plug-Hole
13	107-2831	1	Bracket-Monitor
14	106-7995-03	1	Control Box Mount ASM
15	3234-26	4	Screw
16	104-1451	4	Screw-Tap, PPH
17	283-6	1	Pin-Clevis
18	3290-307	1	Pin-Hair
19	3234-17	4	Screw-HHF
20	104-8300	4	Nut-Flange, NI
21	3234-4	4	Screw-HHF
22	32128-33	4	Nut-HF
23	99-6137	1	Knob-Control, Chute
25		1	Control Enclosure ASM
25:1	106-1378	1	Base-Enclosure, Control
25:2	106-1349	1	Cover-Enclosure, Control
26	107-2825	1	Decal-Switchplate
27	2412-4	1	Clamp

Ref	Part No.	Qty.	Description
28	3250-32	1	Screw-PPH
29	3256-2	1	Washer-Flat
30	3296-42	1	Nut-Lock, NI
31	70-1480	1	Relay

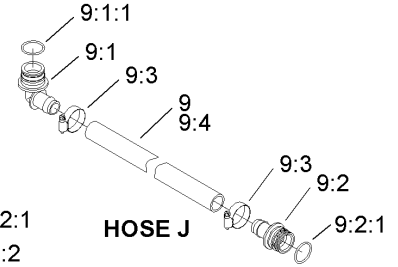
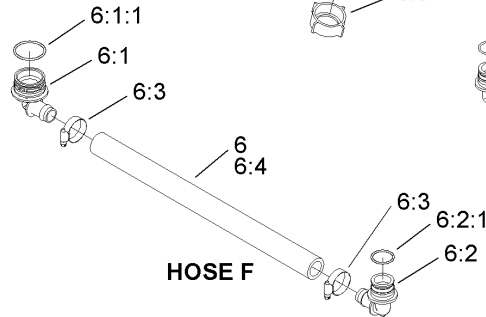
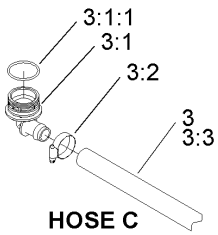
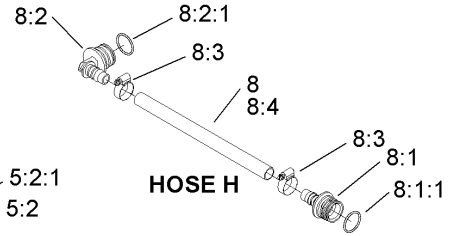
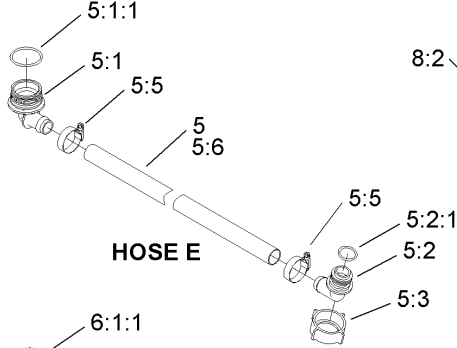
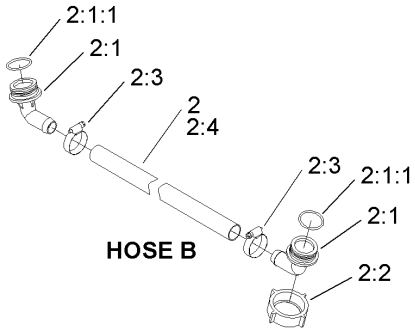
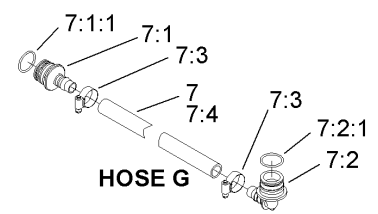
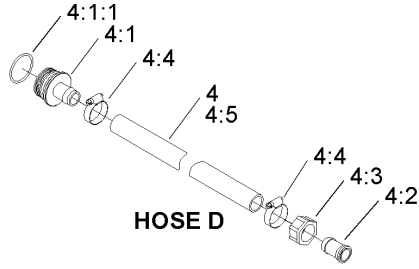
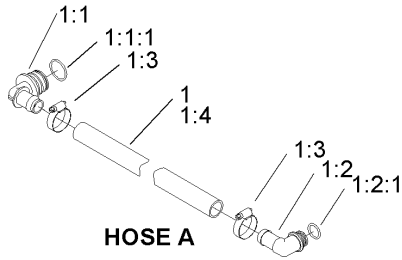

Hose Assembly

Ref	Part No.	Qty.	Description
②1		1	Boom Bypass Hose ASM
1:1	106-4945	1	Elbow
1:1:1	100-6712	1	O-Ring
1:2	106-4948	1	Hose Barb ASM
1:2:1	100-6882	1	O-Ring
1:3	2412-3	2	Clamp-Hose
1:4	104-9037	1	Hose-Boom Bypass
②2		1	Agitation Supply Hose ASM
2:1	106-4950	2	Hose Barb ASM
2:1:1	100-8671	1	O-Ring
2:2	100-8669	1	Nut
2:3	2412-3	2	Clamp-Hose
2:4	104-8710	1	Hose
②3		1	Tee Controls Hose ASM
3:1	106-4933	1	Hosebarb ASM
3:1:1	100-8637	1	O-Ring
3:2	2412-3	1	Clamp-Hose
3:3	107-2832	1	Hose
②4		1	Manifold Tee Hose ASM
4:1	106-4932	1	Hosebarb-Straight
4:1:1	100-8637	1	O-Ring
4:2	99-0781	1	Hosebarb
4:3	99-0769	1	Nut
4:4	2412-3	2	Clamp-Hose

Ref	Part No.	Qty.	Description
4:5	107-2807	1	Hose
②5		1	Relief Valve Hose ASM
5:1	106-4933	1	Hosebarb ASM
5:1:1	100-8637	1	O-Ring
5:2	106-4949	1	Hosebarb-110 DEG
5:2:1	100-6646	1	O-Ring
5:3	100-8678	1	Nut
5:5	2412-3	2	Clamp-Hose
5:6	104-8710	1	Hose
②6		1	Agitation Valve Hose ASM
6:1	106-4933	1	Hosebarb ASM
6:1:1	100-8637	1	O-Ring
6:2	106-4945	1	Elbow
6:2:1	100-6712	1	O-Ring
6:3	2412-3	2	Clamp-Hose
6:4	106-4975	1	Hose
②7		1	Front Agitation Hose ASM
7:1	106-4939	1	Hosebarb-Straight
7:1:1	100-6712	1	O-Ring
7:2	106-4940	1	Hosebarb-90 DEG
7:2:1	100-6712	1	O-Ring
7:3	2412-129	2	Clamp-Hose
7:4	107-2813	1	Hose
②8		1	Middle Agitation Hose ASM

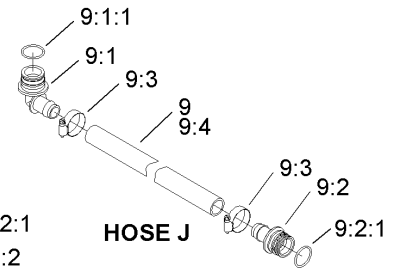
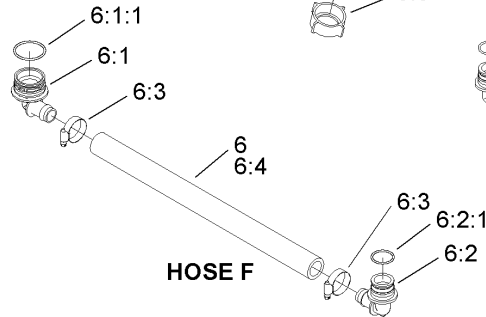
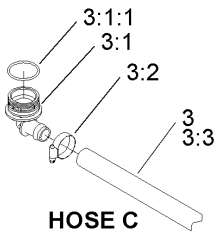
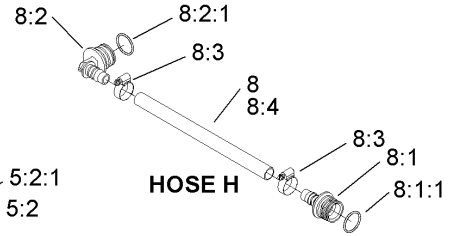
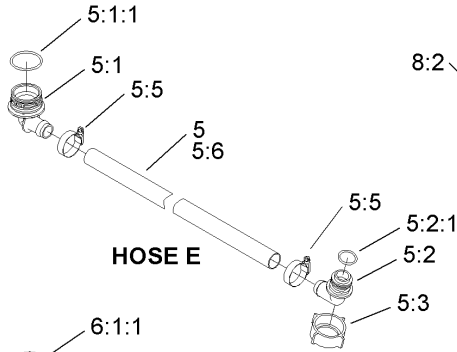
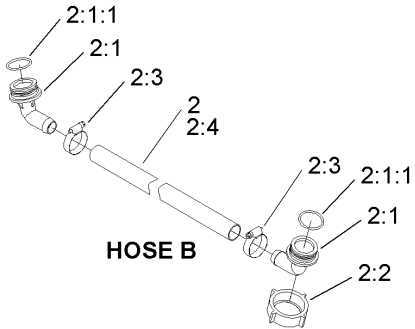
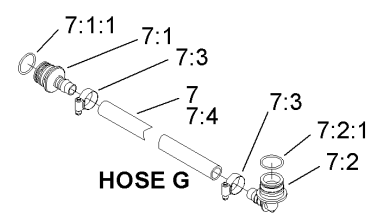
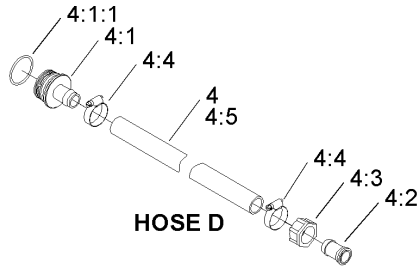
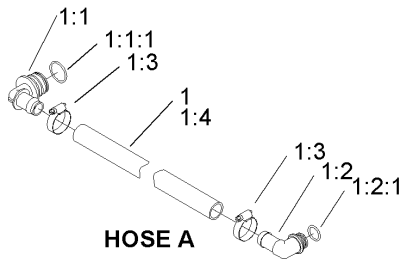

Hose Assembly (continued)

Ref	Part No.	Qty.	Description
8:1	106-4939	1	Hosebarb-Straight
8:1:1	100-6712	1	O-Ring
8:2	106-4940	1	Hosebarb-90 DEG
8:2:1	100-6712	1	O-Ring
8:3	2412-129	2	Clamp-Hose
8:4	106-1360	1	Hose
9		1	Agitation Tee Hose ASM
9:1	106-4945	1	Elbow
9:1:1	100-6712	1	O-Ring
9:2	106-4935	1	Hosebarb ASM
9:2:1	100-6712	1	O-Ring
9:3	2412-3	2	Clamp-Hose
9:4	107-2812	1	Hose

--	--	--	--

NOTES

