



Operator's Manual

Turf Pro™ 200 Robotic Mower

Model—Serial Range

30927EU—326000000 and Up

30927US—326000000 and Up

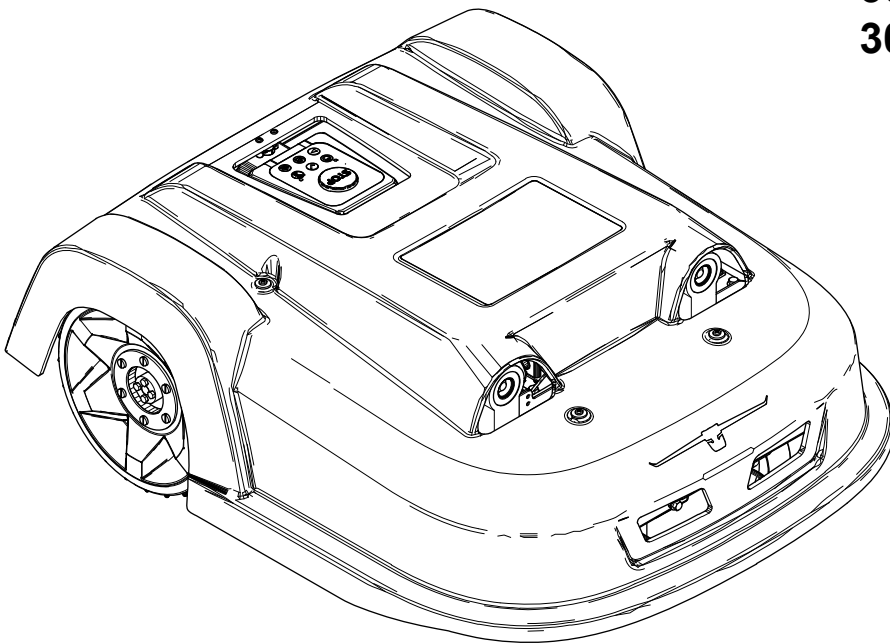

Disclaimers and Regulatory Information

▲ WARNING

CALIFORNIA Proposition 65

This product contains a chemical or chemicals known to the State of California to cause cancer, birth defects, or reproductive harm.

Electromagnetic Compatibility Certification

Domestic: This device complies with FCC Rules Part 15. Operation is subject to the following two conditions: (1) This device may not cause harmful interference and (2) this device must accept any interference that may be received, including interference that may cause undesirable operation.

FCC ID: 2AJYU-8PYA007, TFB-1004

This device contains licence-exempt transmitter(s)/receiver(s) that comply with Innovation, Science and Economic Development Canada's licence-exempt RSS(s). Operation is subject to the following two conditions: (1) This device may not cause interference. (2) This device must accept any interference, including interference that may cause undesired operation of the device.

IC: 23761-8PYA008, 5969A-1004

Table of Contents

Chapter 1: Introduction.....	1-1
Intended Use	1-1
Getting Help	1-1
Manual Conventions.....	1-2
Safety Alert Classifications.....	1-2
Chapter 2: Safety.....	2-1
General Safety	2-1
Operation Safety.....	2-1
Maintenance Safety	2-2
Battery and Charging Station Safety	2-2
Storage Safety	2-4
Safety and Instructional Decals	2-4
Chapter 3: Setup.....	3-1
Installing the Cutting Discs	3-1
Chapter 4: Product Overview	4-1
Controls.....	4-4
Power Switch.....	4-4
Sensor Overview	4-5
Stop Button	4-5
Obstacle Detection Sonars	4-5
Collision and Lift Sensors	4-6
Coil.....	4-6
Tilt Sensor	4-7
Rollover Sensor	4-7
Temperature Sensor	4-7
Attachments/Accessories.....	4-7
Charging Station Overview	4-8
LED Indicator.....	4-9
Specifications	4-10
Chapter 5: Operation	5-1
Before Operation	5-1
Performing Daily Maintenance.....	5-1
Operating the Turf Pro Robotic Mower.....	5-1
Operation Terminology	5-2
During Operation	5-4
Leaving the Charging Station	5-4
Returning to the Charging Station	5-5
Pattern Mowing	5-6
Overview of the Keypad.....	5-8
Blade Care Tips	5-9
Installing the Machine.....	5-10
Using the Virtual LED Screen.....	5-10
Overview of the Menus	5-14
Connecting to a Different Known Network	5-28
Using the Robot as a Client	5-29
Chapter 6: Maintenance	6-1
Maintenance Overview	6-1
Recommended Maintenance Schedule.....	6-2
Pre-Maintenance Procedures	6-3
Preparing for Maintenance.....	6-3
Cutting Unit Maintenance	6-3

Inspecting the Cutting Unit	6-3
Replacing the Cutting Blades	6-4
Cleaning.....	6-4
Cleaning the Machine.....	6-4
Cleaning the Charge Contacts	6-5
Cleaning the Sonar Sensors.....	6-5
Cleaning the Front Wheels.....	6-5
Cleaning the Front Wheel Axles	6-6
Cleaning the Cutting Head	6-7
Cleaning the Cutting Disc	6-7
Cleaning the Rear Wheels	6-7
Electrical System Maintenance	6-7
Checking the Wiring.....	6-7
Battery Service.....	6-8
Chapter 7: Storage	7-1
Storing the Machine	7-1
Removing the Machine from Storage	7-1
Chapter 8: Notices.....	8-1
Chapter 9: Abbreviations	9-1
Chapter 10: Glossary.....	10-1
California Proposition 65 Warning Information	



WARNING



Failing to follow the operating instructions or to receive training from an authorized Toro distributor may result in death or serious injury.

- To maximize the safety, performance, and proper operating of this machine, carefully read and fully understand the content of this *Operator's Manual*.
- For more information on safe operating practices, including safety tips and training materials, go to www.Toro.com.

Intended Use

This robotic lawnmower is intended to be used by professional, hired operators for autonomous, programmable lawn care. It is designed primarily for cutting grass on well-maintained lawns on commercial properties. This is a maintenance lawnmower that maintains the height of the grass consistently. Using the mower, battery, charging station, and base station for purposes other than their intended use could endanger you and bystanders.

Read this information carefully to learn how to operate and maintain your product properly and to avoid injury and product damage. You are responsible for operating the product properly and safely.

Getting Help

Visit www.Toro.com for product safety and operation training materials, accessory information, help finding a dealer, or to register your product.

Whenever you need service, genuine Toro parts, or additional information, contact an authorized Toro distributor or Toro Customer Service and have the model and serial numbers of your product ready. These numbers are located on the serial plate on your product . Write the numbers in the space provided.

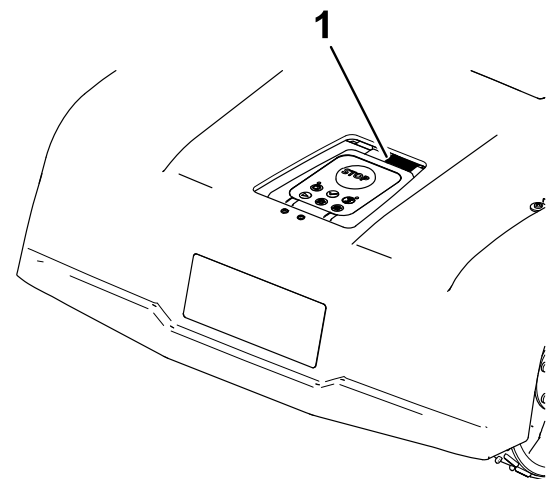

G595651

IMPORTANT

With your mobile device, you can scan the QR code on the serial number decal (if equipped) to access warranty, parts, and other product information.

Model Number:		Serial Number:	
---------------	--	----------------	--

Manual Conventions

This manual identifies potential hazards and has safety messages identified by the safety-alert symbol, which signals a hazard that may cause serious injury or death if you do not follow the recommended precautions.



This manual uses 2 words to highlight information. **Important** calls attention to special mechanical information and **Note** emphasizes general information worthy of special attention.

Safety Alert Classifications

The safety-alert symbol shown in this manual and on the machine identifies important safety messages that you must follow to prevent accidents.

Safety-alert symbol appears above information that alerts you to unsafe actions or situations and is followed by the word **DANGER**, **WARNING**, or **CAUTION**.



DANGER



Danger indicates an imminently hazardous situation which, if not avoided, *will* result in death or serious injury.



WARNING



Warning indicates a potentially hazardous situation which, if not avoided, *could* result in death or serious injury.



CAUTION



Caution indicates a potentially hazardous situation which, if not avoided, *may* result in minor or moderate injury.



General Safety

- The operator/supervisor of the machine is responsible for any accidents or hazards occurring to others or their property.
- Read, understand, and follow all these instructions and warnings before using the machine.
- Improperly using or maintaining the machine could result in serious injury or death. To reduce this potential, follow all safety instructions.
- Do not allow children or untrained people to operate or service this machine. Allow only people who are responsible, trained, familiar with the instructions, and physically capable to operate or service the machine.

Operation Safety

- Before operating the machine, ensure that there is a physical barrier (e. g., a low fence or a boundary wire) or that the boundary of the operating area is set at least 8 m (26 ft) away from hazards.
- Keep bystanders and children away from the machine and charging station during operation.
- Wear appropriate clothing, including long pants and substantial, slip-resistant footwear, whenever you manually operate the machine.
- Do not operate the machine without all safety protective devices in place and working properly.
- Inspect the area where you will use the machine and remove all objects that could interfere with the operation of the machine.
- The blades are sharp; contacting the blades can result in serious personal injury. Press the stop button and wait for all moving parts to stop before unclogging, servicing, or transporting the machine.
- Keep your hands and feet away from moving parts on and under the machine.
- Do not overreach. Keep proper footing and balance at all times. This enables better control of the machine in unexpected situations. Walk, never run when training the machine.
- Do not stand, sit, or ride on the machine or allow others to do so.
- If the machine strikes an object and/or starts to vibrate abnormally, immediately shut off the machine and wait for all movement to stop before examining the machine for damage. Make all necessary repairs before resuming operation.
- Press the stop button on the machine, wait for all movement to stop, and disable the machine in the following situations:

- Before clearing blockages on the machine
- Before checking, cleaning, or maintaining the machine (especially the blades), and the charging station
- After the machine strikes a foreign object, is in an accident, or breaks down; examine the machine for damage and make repairs before resuming operation
- If the machine begins to vibrate abnormally; examine the machine for damage and make repairs before resuming operation
- Do not place any object on either the machine or the charging station.
- Do not modify the machine, software, charging station, or base station.
- Do not modify or override the machine controls or safety devices.
- Do not use a modified machine, charging station, or base station.
- We recommend not using the machine while watering or irrigating the operating area.
- Use only accessories approved by Toro to avoid the risk of fire, electric shock, or injury.
- Press the stop button on the machine and wait for the blades to come to a complete stop before handling the machine.
- Do not connect a damaged power cord. Do not touch a live damaged cord.
- Do not use the charging station power supply during severe weather.

Maintenance Safety

- Before servicing the machine, turn the power switch underneath the machine to the OFF position.
- Do not allow children to clean and maintain the machine.
- Keep your hands and feet away from moving parts on and under the machine.
- The blades are sharp; contacting the blades can result in serious personal injury.
 - Shut off the machine.
 - Wear cut-resistant gloves when servicing the blades.
 - Do not repair or alter the blades.
- Inspect the machine often to ensure that the blades are not worn or damaged.
- Maintain or replace safety and instruction labels as needed.
- For best performance, use only genuine Toro replacement parts and accessories. Other replacement parts and accessories could be dangerous.

Battery and Charging Station Safety

- Clean the charging terminals on the machine and/or charging station using a nonconductive tool (cloth or soft brush); otherwise, damage may occur.
- Wipe the charging terminals on the charging station and machine using a clean, dry cloth if they are dirty.
- When servicing the battery, do not wear jewelry and tie back long hair.

- Do not dismantle or open the battery.
- Keep the battery clean and dry.
- Do not use or charge the machine if it is unusually hot or emits smoke or an unusual smell.
- Leaking battery fluid can cause skin and eye irritation or chemical burns.
- If the battery leaks, do not allow the liquid inside the battery to contact skin or eyes. If there is contact, wash the affected area with a large amount of water and seek medical advice.
- Use an inert absorbent such as sand to clean up spilled battery fluid.
- Dispose of a used battery properly.
- Do not dispose of the battery in a fire. The cell may explode. Check with local codes for possible special disposal instructions.
- A mistreated battery may present a risk of fire, explosion, or chemical burn.
- Do not disassemble the battery.
- Replace the battery with an approved battery only; using another type of battery may cause a fire or risk of injury.
- Keep the battery out of the reach of children.
- Use only the battery approved by the manufacturer for the machine. Do not use any battery that is not designed for use with the machine.
- Do not use a damaged or modified battery, which may exhibit unpredictable behavior that results in fire, explosion, or risk of injury.
- Avoid using the machine in bad weather conditions, especially whenever there is a risk of lightning.
- Do not use or charge a damaged, deformed, or excessively hot battery. A damaged battery may generate heat, rupture, leak, ignite, or explode.
- Use the battery only for the application for which it was intended.
- The battery could emit explosive gasses if it is significantly overcharged.
- Do not subject the battery to mechanical shock.
- Do not use or operate a damaged or improperly functioning charging station.
- Do not plug the charging station into a power strip or an extension cord.
- Do not operate a charging station that has received a sharp or heavy blow.
- Do not use a charging station other than that designed for the machine.
- Disconnect the charging station from the electrical outlet before performing maintenance on or cleaning it to reduce the risk of electric shock.
- Do not attempt to repair, open, or disassemble the charging station unless you are authorized to do so.
- Take the charging station to an authorized Toro distributor for service or repair. Do not disassemble the charging station.

Storage Safety

- When you are not using the machine, store it indoors in a dry, secure place out of the reach of children or other unauthorized users.

Safety and Instructional Decals



Safety decals and instructions are easily visible to the operator and are located near any area of potential danger. Replace any decal that is damaged or missing.

Decal Part: 163-3955



s_decals163-3955

- ① Warning—read the *Operator's Manual*.
- ② Cutting/dismemberment hazard of hands and feet—shut off the machine before performing maintenance.
- ③ Thrown object hazard—keep bystanders away.
- ④ Cutting/dismemberment hazard of hands and feet—do not ride on the machine.
- ⑤ Keep pets and animals away from the machine.
- ⑥ Do not spray the machine with water.
- ⑦ The machine is protected by an access code.
- ⑧ Keep bystanders away and keep children supervised.
- ⑨ Wear protective gloves when servicing the blades.
- ⑩ The machine is equipped with an anti-theft system.

Installing the Cutting Discs

Parts Required

1	Cutting disc kit
---	------------------

⚠ WARNING ⚠

The blades are sharp; contacting the blades could result in serious personal injury. Wear cut-resistant gloves and use care when replacing or cleaning the blades.

1. Remove the body shell from the machine.
2. Using the handle at the front of the machine, lift the machine and stand the machine on its rear.
3. Rotate each cutting motor shaft so that the flat surfaces on the shafts face up.

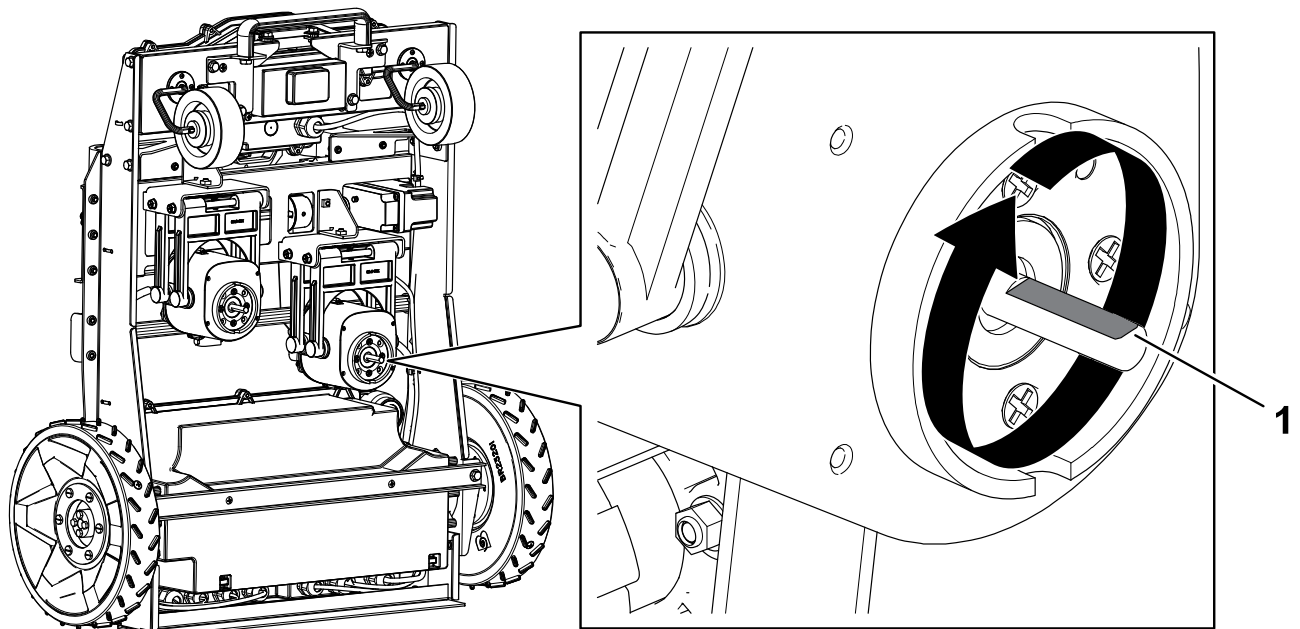

G594819

① Flat surface on motor shaft

- Slide the cutting discs for the machine onto the shafts. Ensure that the set screws on the cutting discs are aligned with the flat surfaces on the shafts.

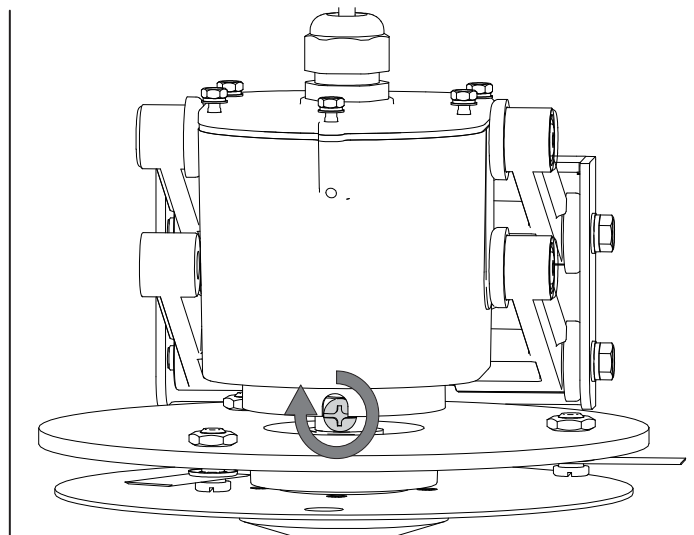
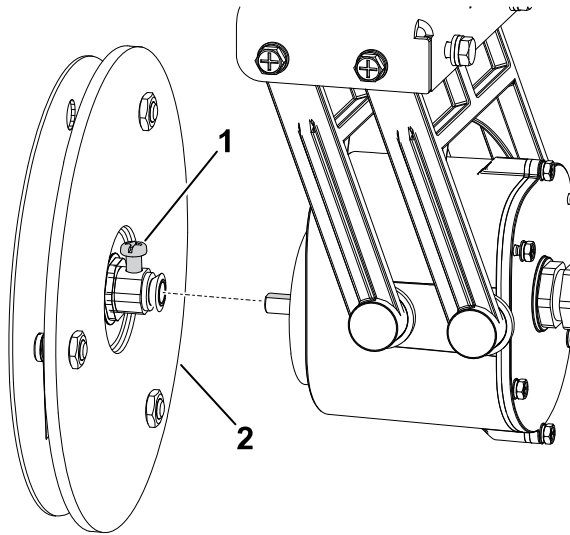

G575619

① Set screw

② Cutting disc



- Tighten the set screws to a torque of **1.7 N·m (15 in-lb)**.
- Lower the machine to the ground and install the body shell.



Product Overview

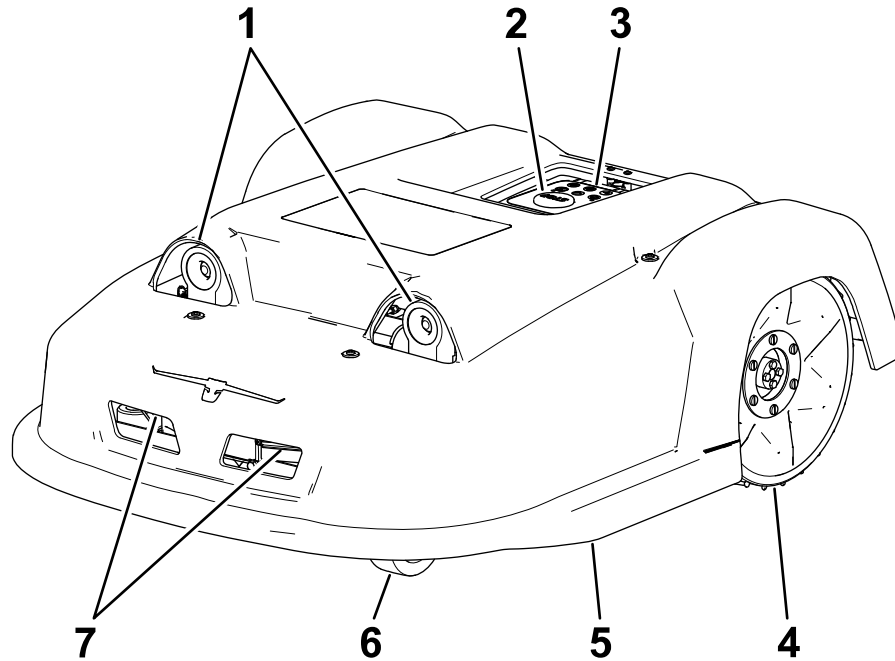

G593021

- ① Obstacle detection sonars
- ② Stop button
- ③ Keypad
- ④ Rear wheels
- ⑤ Body shell
- ⑥ Front wheels
- ⑦ Charge contacts

Figure 1 Bottom view

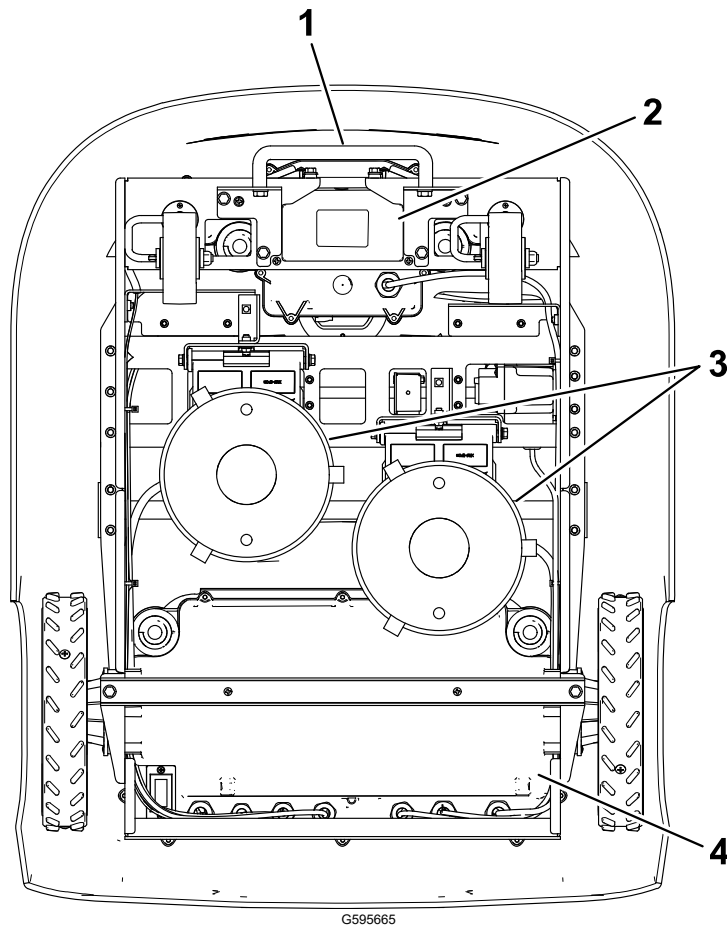

- ① Handle
- ② Front box. Contains the coil for detecting the station loop wire.
- ③ Cutting discs
- ④ Rear box. Contains electronics and the motors for the rear wheels.

Figure 2 Top view (shell removed)

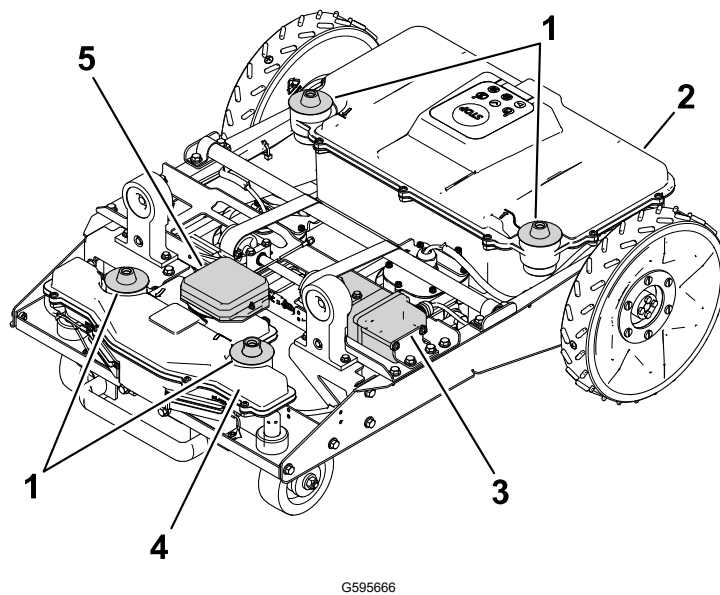

- ① Body shell supports
- ② Rear box
- ③ Cutting-height motor
- ④ Front box
- ⑤ RTK GPS antenna

Figure 3 Cutting head

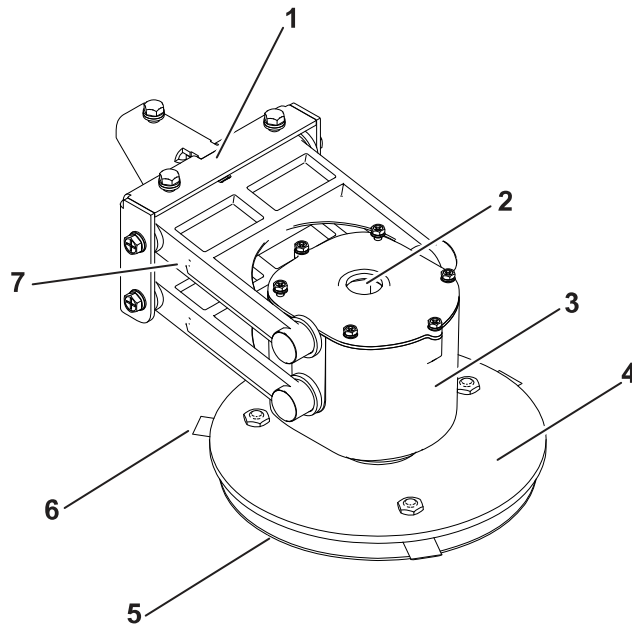

G526500

- | | | | |
|---------------|----------------------|----------------------|--------------|
| ① Bracket | ③ Motor housing | ⑤ Anti-friction disc | ⑦ Pantograph |
| ② Cable entry | ④ Blade-support disc | ⑥ Cutting blade | |

Note: The blade-support disc ④, the anti-friction disc ⑤, and the cutting blades ⑥ are referred to collectively as the "cutting disc".

Controls

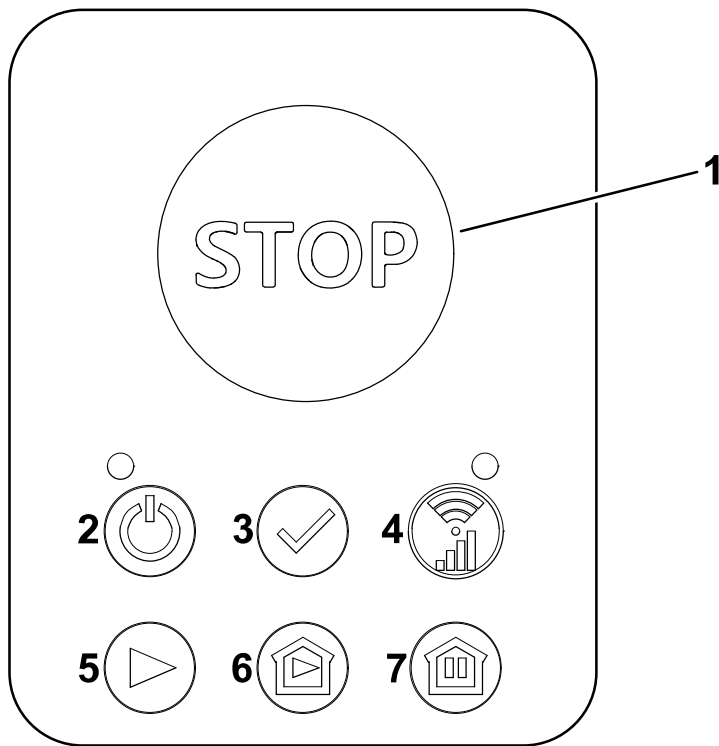

- ① Stop button
- ② On/Off button and status LED
- ③ Confirm
- ④ GPS/RTK status LED
- ⑤ Work button
- ⑥ Charge and work button
- ⑦ Charge and stay button

Power Switch

The power switch is located under the shell on the right-rear of the robot.

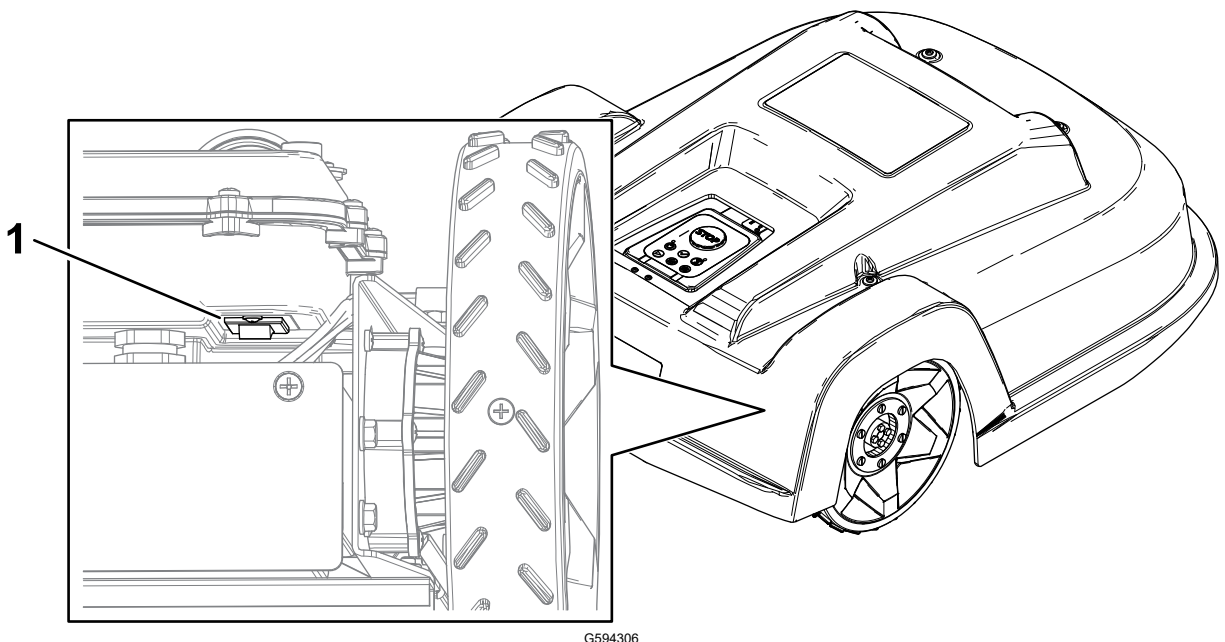

- ① Power switch

Sensor Overview

The machine is equipped with a comprehensive set of sensors that ensure its safe operation. These sensors ensure that the robot can detect and react if an obstacle lies in its path.

Stop Button

The stop button ^① is easily visible, located on the top of the robot. Pressing this button will cause the robot to stop moving and cutting. An instruction must be issued using this control interface in order to restart the robot.

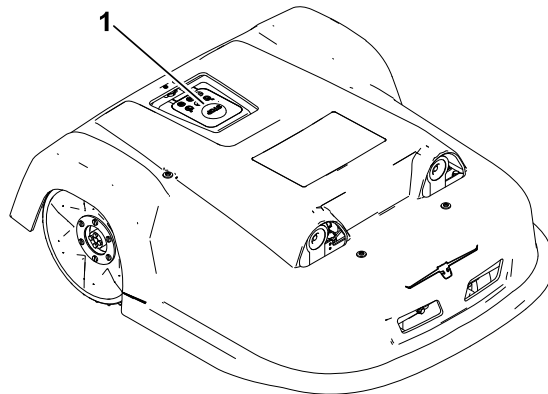

G601194

Obstacle Detection Sonars

The robot is equipped with a set of sonar sensors to detect obstacles. The robot will reduce speed if the sonar detectors detect an obstacle.

Detection of obstacles by sonar sensors

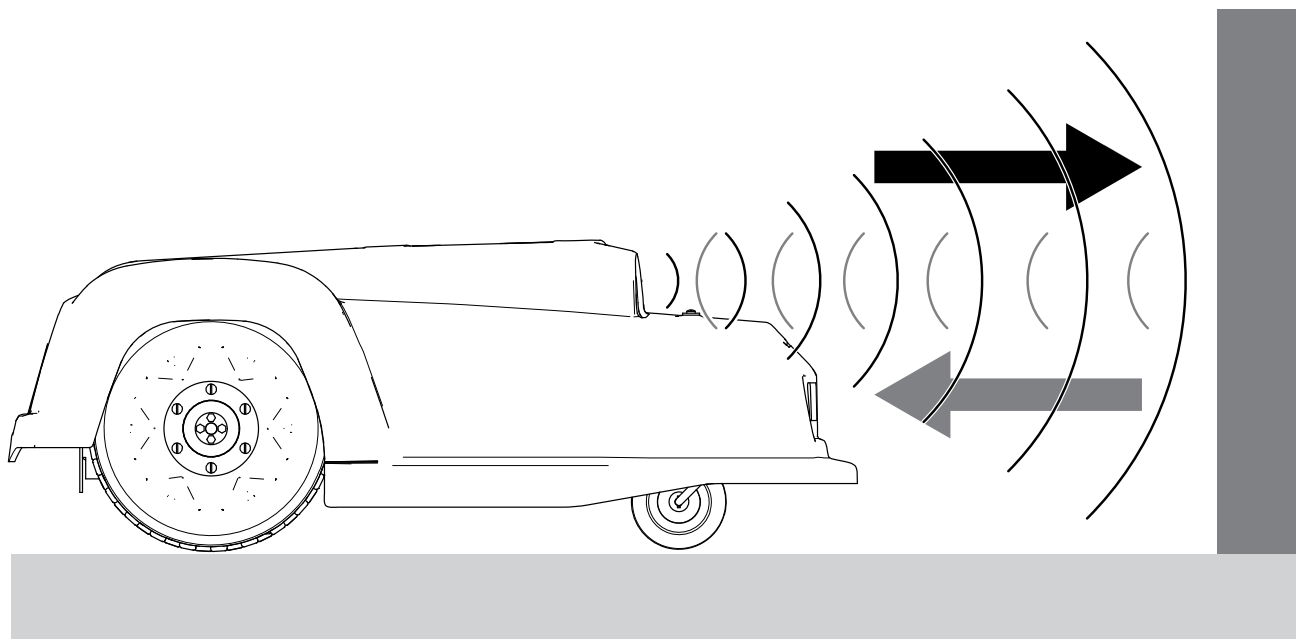

G593556

If the robot is always moving at a slow speed, even if there are no obstacles in view, it indicates a problem with the sensors. In this case you should contact the service team for help in analyzing the problem.

Collision and Lift Sensors

Magnets used by the collision and lift sensors are located on the inside of the body shell.

Note: The shell must be installed correctly on the chassis for the robot to operate.

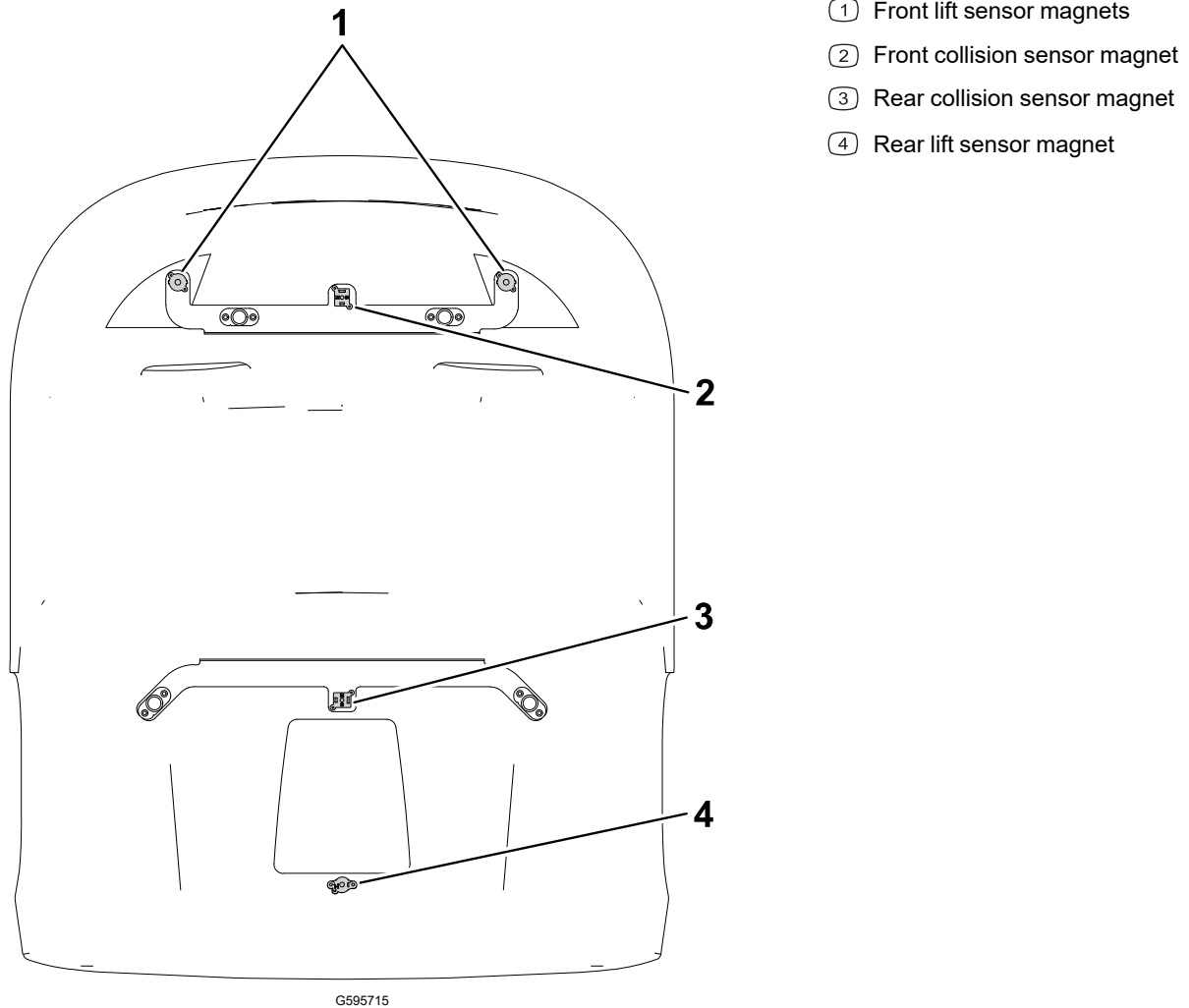

Lift sensors are attached to the body of the robot at 3 points. If the robot touches a low object that pushes the bodywork up, or if someone tries to lift the body, the lift sensors will react. The robot will stop mowing and move backwards. If this movement frees the obstacle from the body, the robot will perform a maneuver to avoid the object and continue mowing. If not, the robot will register an alarm after 10 seconds and remain in safe mode (stationary) until the obstacle is removed.

Coil

The induction coil detects the intensity of the magnetic field that is generated within the peripheral wire. The maximum intensity is located on the wire, which causes the robot to stop, rotate, and continue mowing in a new direction.

Tilt Sensor

The tilt sensor detects the angle of the slope on which the robot is working. An alarm is raised and the robot stops moving if the angle is exceeded.

Rollover Sensor

The rollover sensor detects whether the robot has been tipped upside down or whether someone is trying to start the motor when the robot is upside down.

Temperature Sensor

The temperature sensor measures the ambient temperature and will prevent the robot from operating if this temperature is too low. The minimum temperature at which the robot can operate is set as an operating parameter.

Attachments/Accessories

A selection of Toro approved attachments and accessories is available for use with the machine to enhance and expand its capabilities. Contact your Authorized Service Dealer or authorized Toro distributor or go to www.Toro.com for a list of all approved attachments and accessories.

To ensure optimum performance and continued safety certification of the machine, use only genuine Toro replacement parts and accessories.

Charging Station Overview

Note: Model 30932EU is shown. The appearance varies slightly depending upon model. Refer to the charging station *Operator's Manual* for more information.

Figure 4 Charging station components

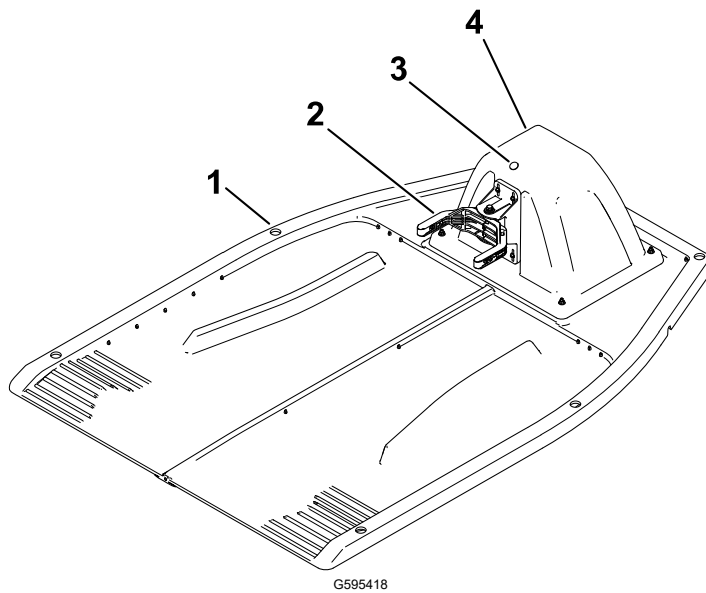

- ① Station base
- ② Charging arm
- ③ LED
- ④ Station enclosure

Figure 5 Bottom view of the station base

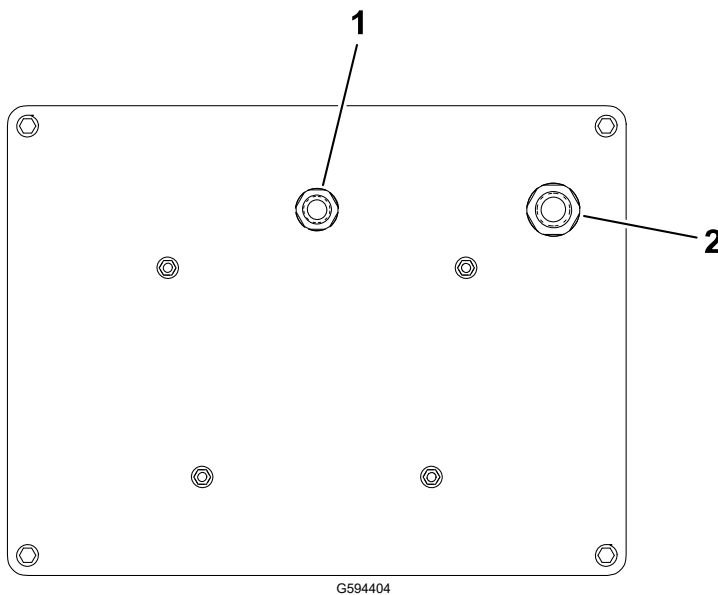

- ① Input for the loop wire
- ② Input for the power cable

LED Indicator

There is a single LED above the charging arm that gives the status of the station.

LED Behavior	Description
Green - blinking	The loop wire is operating normally.
Red - blinking	No wire detected. This could be because the wire has been cut or that it is too long.
Red - continuous	This indicates a problem. This could be due to the wire being too short (less than 200 m or 656 ft) or there is a problem with the electronics. Contact your authorized Toro distributor.

Specifications

Note: Specifications and design are subject to change without notice.

Capacity

Maximum working area	30,000 m ² (7.4 acres)
Recommended working area	22,000 m ² (5.4 acres)
Mowing width	400 mm (15.75 inches)
Working speed	3.6 km/h (2.2 mph)
Maximum slope	30% (17°)

Cutting

Number of cutting heads	2
Number of cutting blades	6 or 12
Minimum cutting height	Standard-height disc: 20 mm (0.8 inches) Medium-height disc: 15 mm (0.6 inches) Low-height disc: 10 mm (0.4 inches)
Maximum cutting height	80 mm (3.2 inches)
Adjustment of cutting heads	Electronic
Maximum noise level (measured at 5 m, or 16 ft)	52 db(A)

Battery

Type	LiFePo4
Nominal voltage	25.6 V
Nominal capacity	8.55 Ah
Energy	194.56 Wh
Working temperature range	-20°C (-4°F) to 60°C (140°F)
Average mowing time	110 minutes
Average time to full charge	55 minutes

Weight and Dimensions

Weight	25 kg (55.1 lb)
Length	899 mm (35.4 inches)

Weight and Dimensions (continued)

Width	724 mm (28.5 inches)
Height	325 mm (12.8 inches)

Software and Monitoring

Security PIN code	Yes
GPS location	RTK
Robot management via server and app.	Standard

Intelligence

Sonar detection of obstacles	Multiple
Return to station via GPS	Yes
Type of mowing	Patterned
Multiple starting zone	Yes
Multi field (optional)	Yes
Multi robots/station	No
Sonars for obstacle detection	2
Front lift sensors	2
Rear lift sensors	1
Rear collision sensors	2
Roll over / tilt sensor	1
Cutting head deflectors	None



Before Operation

Performing Daily Maintenance

Before starting the machine each day, perform the Each Use/Daily procedures listed in the Maintenance Schedule.

Operating the Turf Pro Robotic Mower

Your robot uses the RTK GPS positioning system, which means that it can mow in straight lines following a pattern.

Note: Pattern mowing is only possible when the quality of the GPS signal is high enough to allow it. If the robot encounters difficulties communicating with the satellites, it will stop and try scanning to improve the connection. If the problem persists, an alarm is triggered.

The robot using the RTK GPS positioning system can operate in two types of configurations:

- Within an area defined by a set of GPS way points that creates a safety border
- Within an area defined by a peripheral wire

Your robot has been installed and configured according to your requirements.

To ensure optimal operation of your robot, it is important that it is well-maintained and serviced.

Operation Terminology

Elements of a robot installation

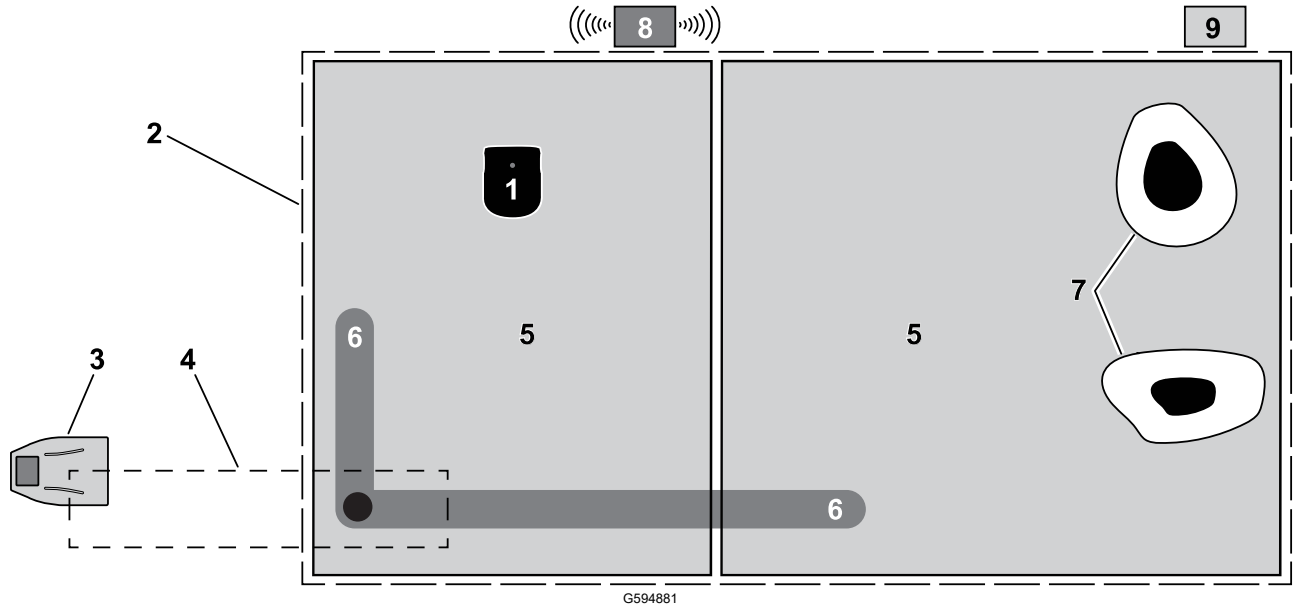

① Robot

The robot contains an antenna that connects with GPS satellites in order to determine its geographic location.

② Working Area

Working areas define the area that the robot is allowed to work in or surround paths that the robot uses for navigation. The boundaries of these areas are discovered by moving the robot around the site. To ensure that the robot stays within the working areas, a number of key configuration parameters are defined. If any one of these are modified, working areas become invalid and the robot will cease operation.

③ Charging Station

The charging station is where the robot returns to either charge its battery or rest if the working schedule is complete. The charging station also emits the signals to all the wires connected to it.

④ Station Loop Wire

A wired loop parcel must be defined for the robot to return to and leave the station. This station loop wire must intersect with a working area or path.

⑤ Internal GPS Zones

Any number of internal GPS zones can be defined to create different working areas. These must be located within the overall working area. They do not need to overlap with the station loop and do not need to be defined by a boundary discovery process.

Operation Terminology (continued)

⑥ Paths

Paths are strings of GPS points that form a route for the robot to navigate between the station and the working areas. A working area automatically surrounds the path at the requested width after the path is discovered and verified.

⑦ NoGo Zones (Exclusion Zones)

This is an area that is defined by GPS points and forms an area that the robot will not work in. This is often created around permanent obstacles.

⑧ RTK Base

An RTK base must be installed to communicate with the satellites and then to communicate the exact position to the robots. This communication can be made using 4G or Wi-Fi. If using Wi-Fi, it may be necessary to use a Wi-Fi repeater. Details about the base can be found in the relevant base *Operator's Manual*.

⑨ Wi-Fi Repeater

When Wi-Fi is being used to communicate the corrections to the robot, it may be necessary to use one or two Wi-Fi repeaters to cover the entire site.

During Operation

Leaving the Charging Station

The robot will leave the charging station under the following conditions:

- The battery is sufficiently charged so that the robot can resume working.
- A specific command has been issued.
- The work schedule dictates that it should work.

Note: In all cases, it is strongly recommended to define a working schedule for the robot.

Mowing a Connected Working Area

The robot follows the station loop wire and reverses out of the charging station. It will then stop, make a 180° turn, and move forward along the loop wire until it senses that it has entered the working area.

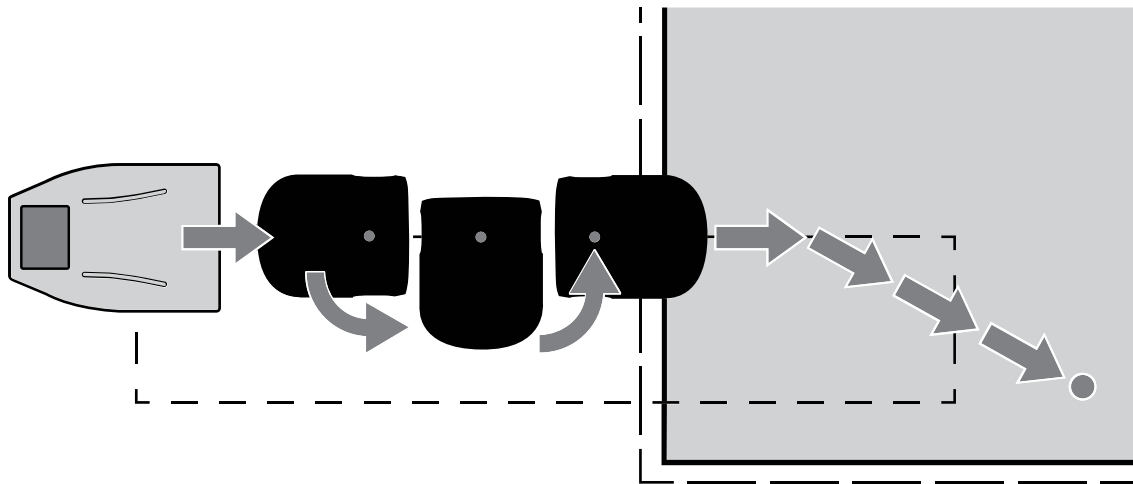

Mowing a Working Area Connected With a Path

For working areas located outside of the loop wire, the robot will need to follow a path to travel to the working area.

The robot will perform the same reversing and turning process before reaching the path, and once it is inside the path zone it will follow the path until it reaches the working area where it is scheduled to work.

Leaving the Charging Station (continued)

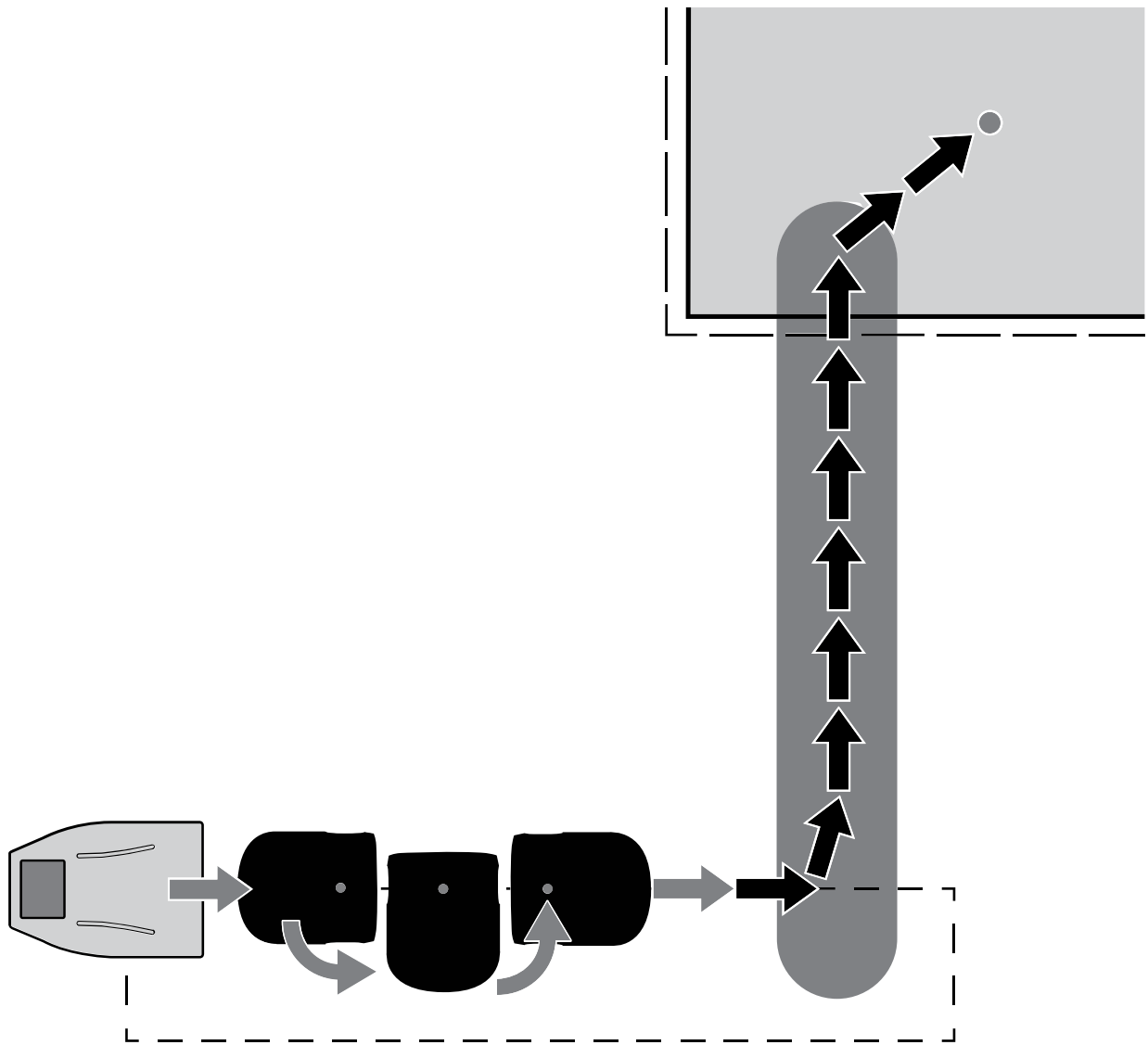

Returning to the Charging Station

The robot will return to the charging station under the following conditions:

- The battery needs to be charged
- The working schedule dictated that it should stop working
- A specific command has been issued

When the robot must return to the charging station, it turns and starts moving directly towards the path connected to the charging station or a GPS return point. The robot will follow the path back to the loop wire, or travel to the GPS return point and follow the loop wire once it has sensed it.

When the robot senses the loop wire, it will turn and follow the wire until it reaches the station.

For the robot to charge, there must be a good contact between the station arms and the contacts on the robot. If the contact is not made, an alarm is issued.

Pattern Mowing

The figure below shows how the robot works in pattern mode. At the start of the working cycle, the robot leaves the station and follows the loop wire until it enters the working area. It calculates the pattern it will follow and moves to the start of the pattern (3). It mows the working area, following a pattern of straight lines for a cycle. A cycle either ends when the battery needs to charge or the schedule dictates that the robot must return to the station (4).

When the robot is due to start work again, it starts a new cycle (5). This second cycle starts at the beginning of the row that the robot was working at the end of cycle 1. The robot continues until the whole of the area has been covered (6). The robot then returns to the station before deciding where it needs to work on the next cycle.

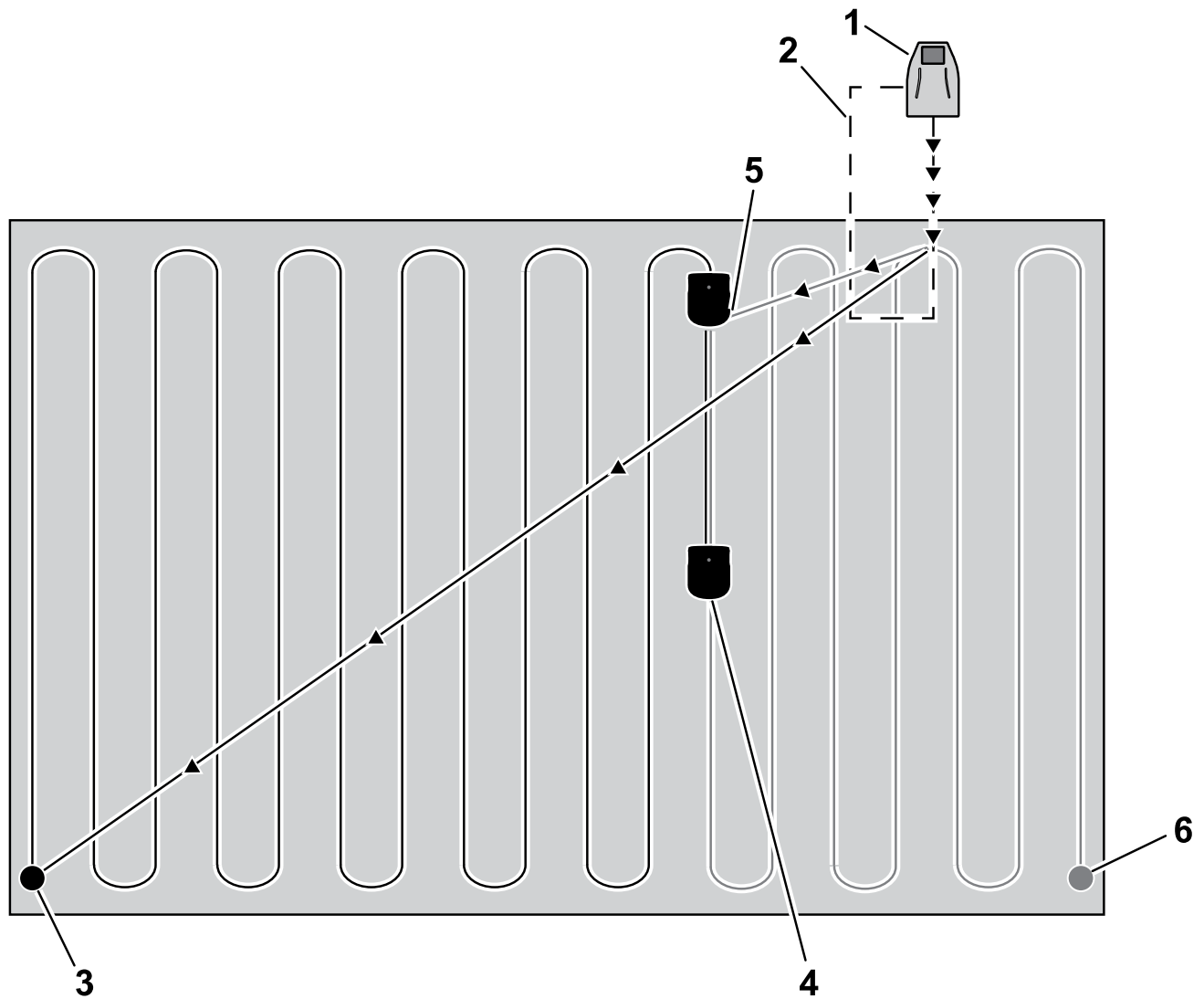

G595464

- ① Charging station
- ② Loop wire

- ③ Cycle 1 start point
- ④ Cycle 1 end point

- ⑤ Cycle 2 start point
- ⑥ Cycle 2 end point

Once the area has been completely mowed, the robot will calculate a new mowing pattern and will rotate the mowing direction to ensure optimal cutting quality and full coverage of the field. In the example shown below, 4 directions are used with angles of 45° between them.

Pattern Mowing (continued)

Rotation of the mowing direction

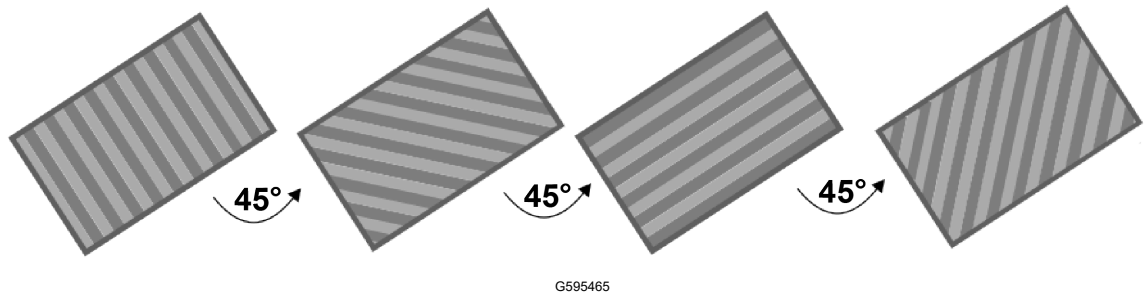

Mowing the Border

During pattern mowing, the robot turns before it reaches the boundary of the GPS working area or the peripheral wire; therefore, the border is not mowed. It is important to ensure that the robot mows the border at least 2 times per week.

The border mowing settings can be set using the following methods:



- If sequential scheduling is used, the mower will automatically mow the border when it has finished mowing a mowing zone.
- To change the border settings for a particular mowing zone, select the mowing zone >  **Settings menu** > **Border** and adjust the number of times the border is mowed per week.

Overview of the Keypad

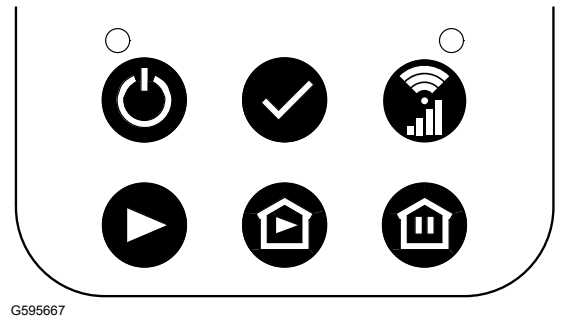
Your machine can be operated through the buttons on the keypad, or through the smartphone app or web portal.









Turning On and Turning Off the Machine

1. Press  for a few seconds to turn the machine on.
2. The machine can be turned off using the following methods:
 - Press  for 1 to 2 seconds (until the status LED blinks red) to shut down the software and then turn off the machine.
 - Pressing  for more than 7 seconds (until the status LED is a constant red) will force the machine to shut off without shutting down the software.

Controlling the Robot From the Keypad

Note: These actions can also be executed from the app or the portal.

Buttons	Result
 + 	Pushing these buttons in sequence will start the robot mowing as long as the schedule and any other conditions allow it.
 + 	Pushing these buttons in sequence will force the robot to return to the charging station and then continue mowing after the battery is charged.
 + 	Pushing these buttons in sequence will force the robot to return to the charging station and stay there until a new instruction is issued.

Releasing the Brakes

To release the brakes on the machine, press  for 2 to 4 seconds (until the status LED blinks yellow).

Overview of the Keypad (continued)

Overview of the Status LED

The LED above  shows the status of the robot.

LED Behavior	Description
Green - blinking	The robot is operating normally.
Red - continuous	Error. The error can be seen on the app and the portal.
Yellow - continuous	The robot is waiting for a new mission.
Yellow - blinking	A new mission has been selected. Press the  button to start the mission.
Blue/yellow - blinking	The robot is at the charging station. It will remain there when the battery is charged.
Blue/green - blinking	The robot is at the charging station. It will start mowing when the battery is charged.
Blue/red - blinking	The robot is at the station in alarm.

Overview of the RTK LED

LED Behavior	Description
Off	The RTK GPS signal quality is sufficient for the robot to operate.
Blue - continuous or blinking	This indicates low GPS quality or no connectivity. Check that the RTK base is operating. Perform a power off/power on. If the situation does not improve, contact your authorized Toro distributor.

Blade Care Tips

The frequency at which blades need to be replaced depends on the robot type, amount of usage, and characteristics of the ground it is working on. Since the condition of the blades is essential for a high quality of cut, it is recommended that you inspect the blades every week after installation and at the beginning of each new mowing season.

The pantograph allows the blade to follow the curves of the ground. If the pantograph is not operating correctly, blades can become blunt or break. The pantograph should be inspected and cleaned regularly.

The following is a list of ways in which you can prolong the life of your cutting blades:

- Ensure that the terrain is even. If the terrain has large bumps or dips in it, the cutting head may not be able to follow the contours of the terrain and may cause the blades to hit the ground. If possible, attempt to even out the terrain, or if necessary exclude very uneven patches from the working area.

Blade Care Tips (continued)

Note: Furrows may appear near the charging station. It is therefore recommended to level the ground near the station or lay artificial turf.

- Remove molehills. When the robot hits a molehill, the blades slow down or may stop. Once past the molehill, the blade returns to a normal speed. The resistance of the earth and the changes in speed might loosen the screws (or damage the screw hole).
- Avoid bare patches. The presence of bare patches within a grassy zone will cause the rotational speed to change. If this speed shift occurs too often, it may damage the pivot and the screw hole. To avoid this problem, raise the height of cut so that the robot is cutting less grass and speed differences are diminished. Alternatively, bare patches can be re-seeded.
- Avoid contact with nylon ground markers. These can cause bluntness. It is recommended to lower them below your height of cut.
- Avoid low solid obstacles in the grass. These include sprinklers, stones, and roots. Stones and other moveable objects should be removed. To avoid permanent solid objects such as sprinklers, set the height of cut to be higher than the obstacle, or adapt the working area to avoid them.

Note: Portable goals are another example of a solid obstacle which can not be detected by the robot. Make sure they are removed before the mowing is scheduled.

- Remove tall weeds near the peripheral wire. Tough tall plants can blunt or damage the blade. It is therefore preferable to keep the areas clear around the peripheral wire.

Installing the Machine

To complete an installation, refer to the *Installation Manual*.

Note: Only users with the role of technician can perform an installation.

Using the Virtual LED Screen

While the keypad offers basic control over the operations of the machine, it is recommended to use the Toro Turf Pro Connect App or the web portal to change the settings on the machine, such as changing the height of cut, changing cutting patterns, and adjusting schedules. It is also possible to use the virtual LED screen on the web portal.

To open the virtual screen in the app, select the **Technician menu** button > **Virtual Screen**. On the web portal, select a machine, then select the **Turf Pro Connect** button > **Technician menu** button > **Virtual Screen**.

Using the Virtual LED Screen (continued)

The LED Screen



G525094

Name

The name of the robot. You can change the robot name under **Service Settings menu > Device > Device info > Robot name**.

Cloud

Indicates that the robot is connected to the web portal.

GPS

Indicates that the robot can detect at least 4 satellites and that it knows its current location. If the GPS indication is blinking, it indicates that the robot cannot detect enough satellites. To see the number of satellites detected, select **Service Settings menu > Device > Device info**.

Mobile signal level

Indicates the robot has a mobile signal.

No mobile connection

This icon indicates that there is no mobile connection.

WiFi/mobile connection

Indicates that the robot is connected as WiFi client. When it is blinking it is trying to connect. When it is steady, it is connected.

Using the Virtual LED Screen (continued)

No WiFi

Indicates that the WiFi setting is OFF.

WiFi access point (AP)

Indicates that the robot is configured as WiFi access point and is waiting for a client to connect.

Battery charge level

Percentage of battery charge.

Message

Shows the current status of the robot or alarm.

User Interface Commands

Commands are available from 3 menus.

Actions

Provides a number of direct missions for the robot.

Settings

Defines parameters controlling the operation of the robot.

Service settings

Provides a set of commands most commonly used by operators and technicians.

The table below lists all the commands available from these 3 menu choices.

Command/parameter	Route
Activation code	Service settings > Device
APN	Service settings > Device > Device info
Bootloader ver.	Service settings > Device > System version
Border	Actions
Border	Settings
Brain version	Service settings > Device > System version
Brake on idle	Service settings > Operations
Change pin code	Service settings > Security > PIN code
Charge & stay	Actions

Using the Virtual LED Screen (continued)

Command/parameter	Route
Cutting heads	Settings
Cutting height	Settings
Date format	Service settings > Regional parameters
Device info	Service settings > Device
Edit parcels percentage	Service settings > Operations
Enable pin code	Service settings > Security > PIN code
Go charge	Actions
IP address	Service settings > Connections
Language	Service settings > Regional parameters
Latitude	Service settings > Device > Device info
Longitude	Service settings > Device > Device info
MAC address	Service settings > Device > Device info
Max short cycles allowed	Service settings > Operations
Min temp	Service settings > Operations
Mode	Service settings > Connections
Mow	Actions
Mow after charge	Actions
Mow now	Actions
PIN code	Service settings > Security
Robot name	Service settings > Device
Schedule	Settings
Search for networks	Service settings > Connections
Serial number	Service settings > Device > Device info
Software version	Service settings > Device > System version
SSID	Service settings > Connections
Stay in station after charge	Actions
System locking	Settings
System version	Service settings > Device
Time zone	Service settings > Regional parameters
Unit system	Service settings > Regional parameters

Using the Virtual LED Screen (continued)

Command/parameter	Route
Version	Service settings > Device > System version
Visible satellites	Service settings > Device > Device info

Overview of the Menus

Actions Menu

The operations provided in this menu depend on the current state of the machine.

- when the robot is in the field
- when the robot is at the charging station

Operations when the Robot is in the Field

Overview of actions menu in the field

Actions menu

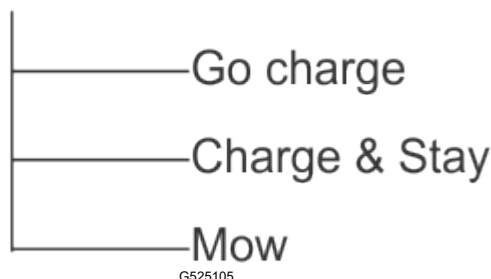

These operations can be performed on the robot when it is not in the charging station.

IMPORTANT

Always stop the robot first by pressing the stop button.

These operations would be performed if the robot has been stopped during its normal operation schedule, or if it has stopped because an alarm has been raised. If an alarm has been raised, you need to correct the problem before executing the operations.

1. **Go charge**

Return to the charging station, charge the battery, and then resume mowing.

2. **Charge & stay**

Return to the charging station and stay there until a new instruction is issued.

3. **Mow**

Continue the mowing schedule after an interruption.

Overview of the Menu (continued)

Operations when the Robot is at the Charging Station

Overview of actions menu at the station

Actions menu

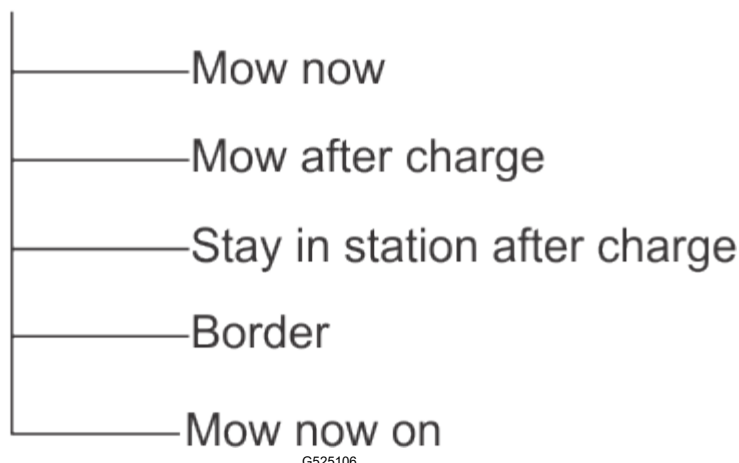

Use these operations to override the regular operating schedule.

1. **Mow now**

Leave the charging station and continue mowing.

2. **Mow after charge**

Remain in the charging station until the battery is charged, then start mowing.

3. **Stay in station after charge**

Stay in the charging station until a new command is issued.

4. **Border**



Execute and then return to the charging station.

5. **Mow now on**

This option appears when there is more than one parcel to be mowed. Leave the charging station and continue mowing in a specific parcel. A list of (neighbouring) parcels appears in which you can choose the required one. Only those parcels with a working percentage of more than 0% are listed.

Executing the Operations

1. Click .

2. Press the up  and down  arrows to highlight the required command, or press the numeric key that appears in front of the command.

3. Press .

4. Close the lid.

Note: If the lid is not closed within 10 seconds, the operation is canceled and you will need to repeat this procedure.

Overview of the Menus (continued)

Note: If the operation does not start even if the lid appears to close the contact; refer to the *Service Manual*.

Settings Menu

These commands enable you to define settings that control the operation of the robot.

Overview of settings menu

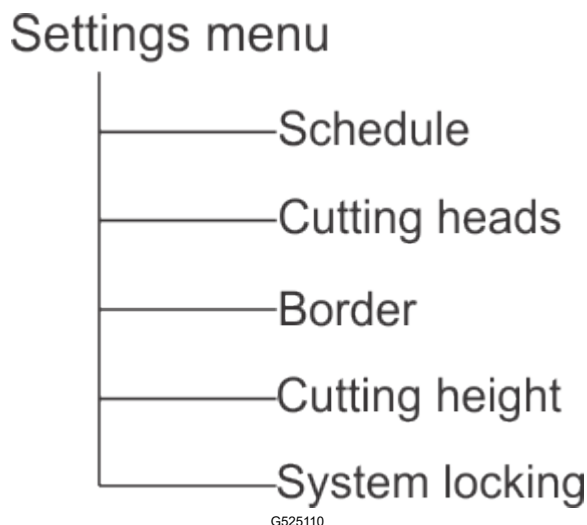

See also: LCD settings.

Schedule





This command enables you define the working schedule for the robot. It defines the times when the robot can or cannot enter a parcel or GPS zone to work.

Note: A schedule can also be defined using the web portal, and is the preferred method for scheduling.

- A working schedule can be defined for each day of the week.
- A number of working periods can be defined for each day, each parcel, and each GPS.
- Each defined period can be active (implemented) or inactive (ignored).
- A schedule for one day, and for one parcel, can be copied to other days of the week.
- The complete schedule can be ignored and the robot set to work at all times.

Defining Working Schedules

Note: By default when the robot is delivered, the schedule is set to work continuously.

1. Press  .
2. Press the up  and down  arrows to highlight Schedule, then press . A screen like the one below will appear. In the example below, there are two columns for each day

Overview of the Menu (continued)

because two parcels that have been defined. This shows the current schedule, where the white blocks represent the time when the robot will be operating in one parcel.

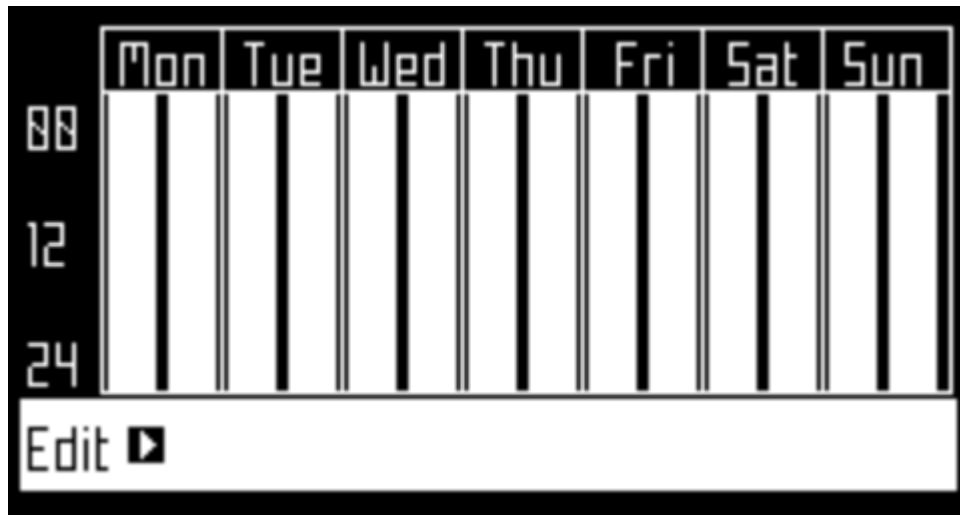

G525111

Note: By default all the time periods will appear white, meaning the robot will work continuously.

3. Use the arrow keys to highlight Edit and press .

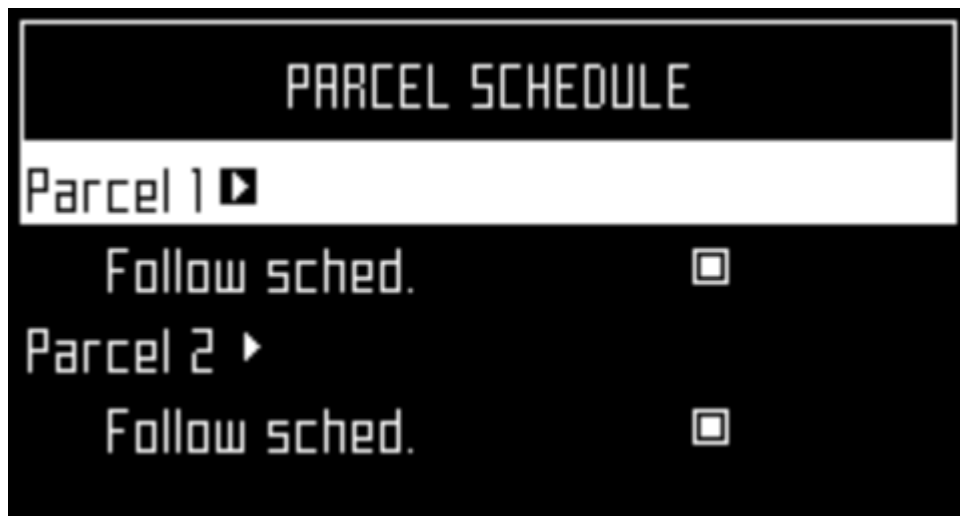

G525112

4. To edit the schedule, highlight the parcel and press .
5. Use the left and right arrows to select the required day of the week, then press .

Overview of the Menus (continued)

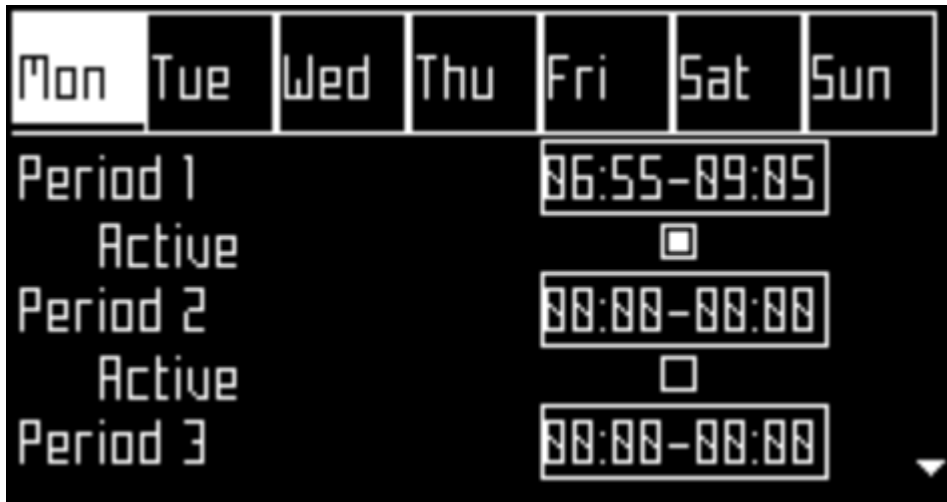

G525113

6. Use the down arrows to select the required period in the day, and press .

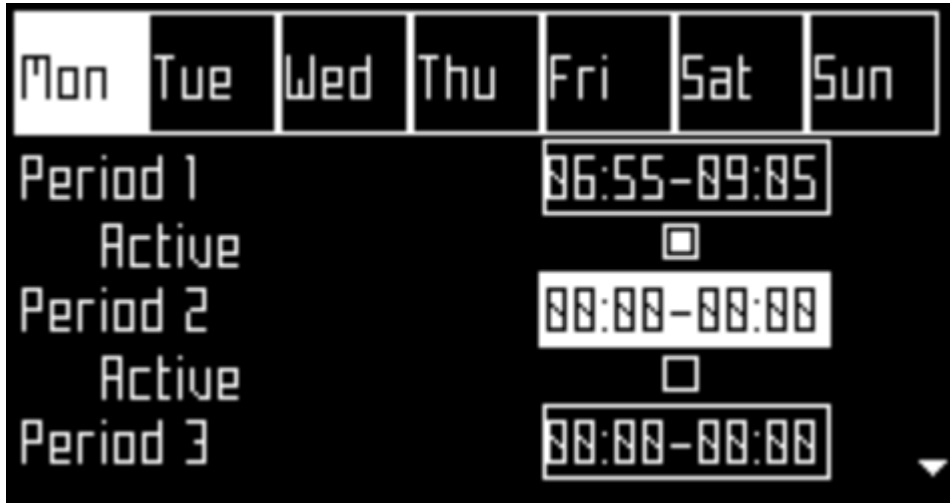

G525114

7. Use the numeric keyboard to enter the start and end time values where the cursor is flashing, then press .

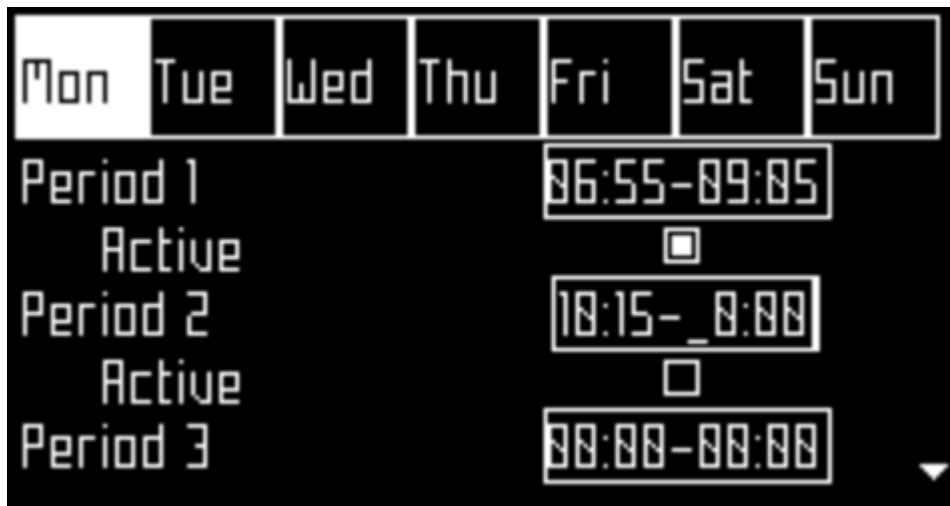

G525116

Overview of the Menu (continued)

8. Press the down arrow key to select the active check box.
9. Press to activate the defined session.
Note: In the figure above, Period 1 is active and Period 2 is inactive.
10. Repeat the process for all the days and the time periods required.
Note: You can copy the defined schedule to another day.
11. Press **X** to return to the Parcel Schedule screen shown above.
12. Use the arrows to select Follow sched. . Press to check the button ON to ensure that the robot follows the defined schedule. When unchecked, the robot will ignore the timetable and work continuously.

IMPORTANT

When creating a schedule for GPS zones, the schedule for the wired parcel associated with the zones must be set to continuous, i.e. shown as solid white.

Copying Schedules from One Day to Another

1. Follow the procedure above to define the mowing schedule for one day.
2. When all the required periods have been defined, use the down key to highlight Copy. Press .

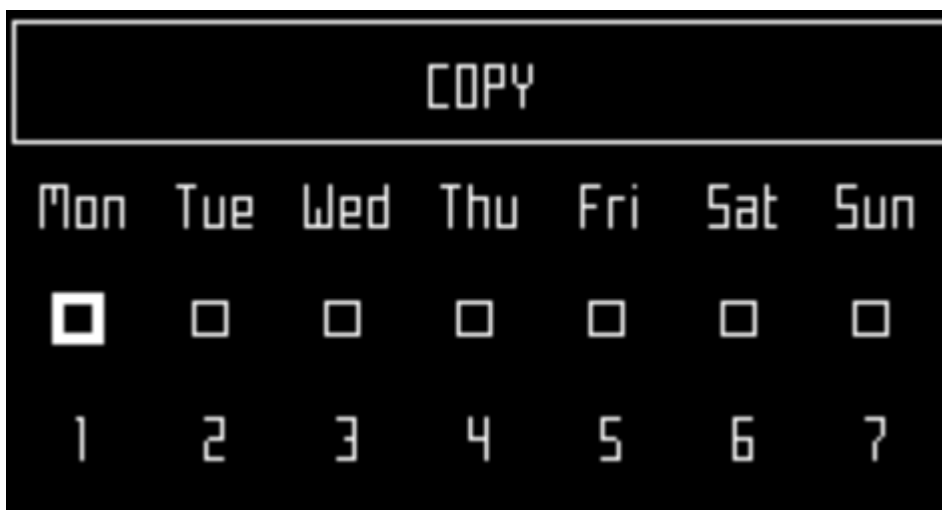

G525118

3. Press the number key that corresponds to the day to which the schedule is to be copied. More than one day can be selected.

Overview of the Menus (continued)

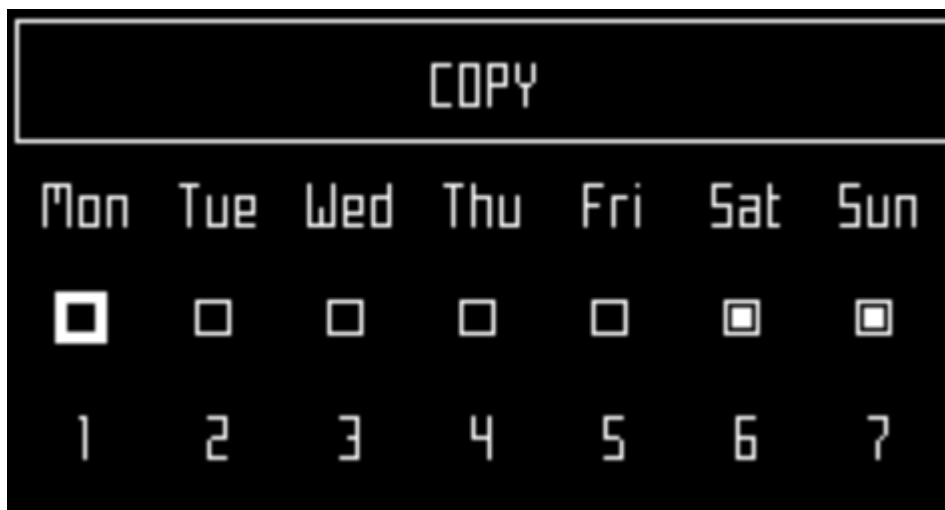

G525119

4. Press .
5. Press **X** to return to the overview of the schedule.

Ignoring the Working Schedule

1. Press .
2. Highlight Edit .
3. Press .
4. Use the arrow keys to highlight Follow sched. and press to uncheck the button.

Cutting Heads

The robot is supplied with cutting heads which, under normal conditions, should all be used. When there is a problem with a cutting head, this command allows you to disable it. This operation can also be executed from the web portal.

Note: It is also possible to disable the cutting heads in a particular parcel.

Enabling/Disabling Specific Cutting Heads

1. Press .
2. Press the up and down arrows to highlight Cutting heads and then press . The following screen appears.

Overview of the Menus (continued)

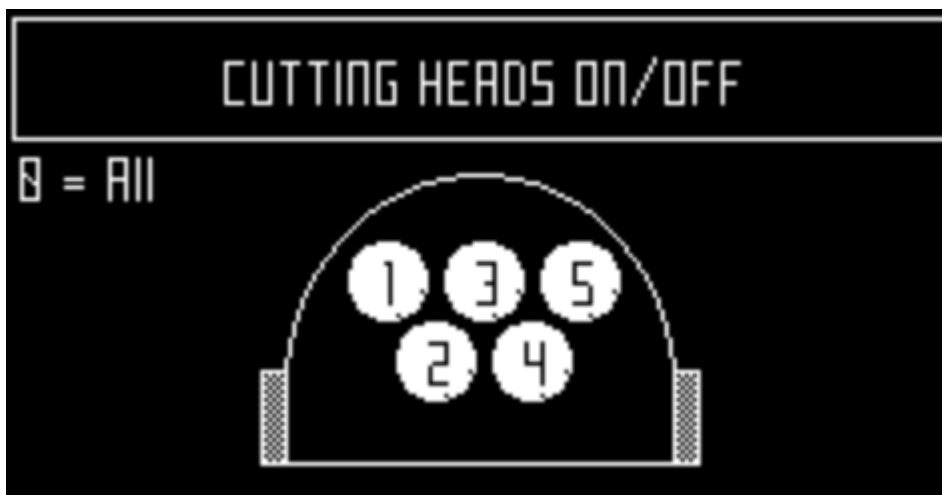

G525121

Note: 500 series shown

Note: This figure indicates that the cutting heads are enabled.

3. Press the number key(s) that corresponds to the cutting head(s) you wish to enable/disable.

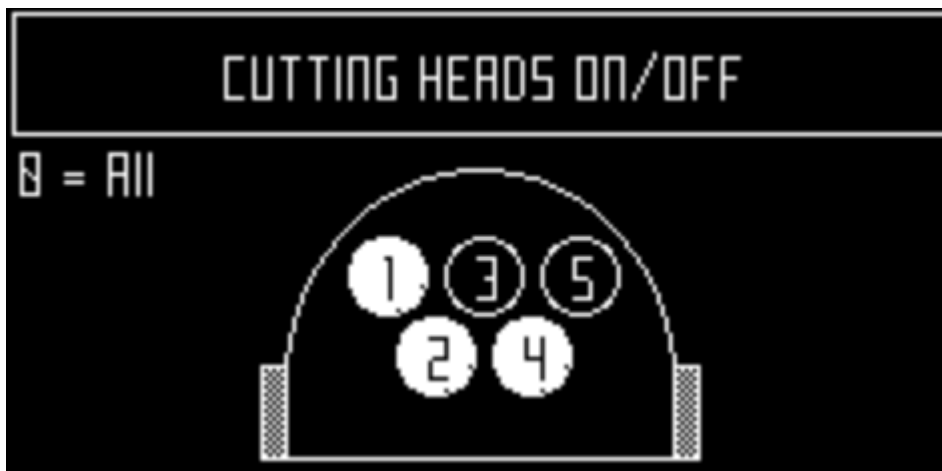

G525122

Note: 500 series shown

Note: Pressing 0 on the numeric keypad will select all the cutting heads.

4. Press .
5. Press **X** to return to the main menu.





Note: To enable a disabled cutting head, repeat the procedure above, selecting the disabled head.

Border

This menu sets the number of times the border mode is used each week for each parcel. The border mode will be implemented at regular intervals during the week.



Overview of the Menus (continued)

Setting the Number of Border Mode Operations Per Week

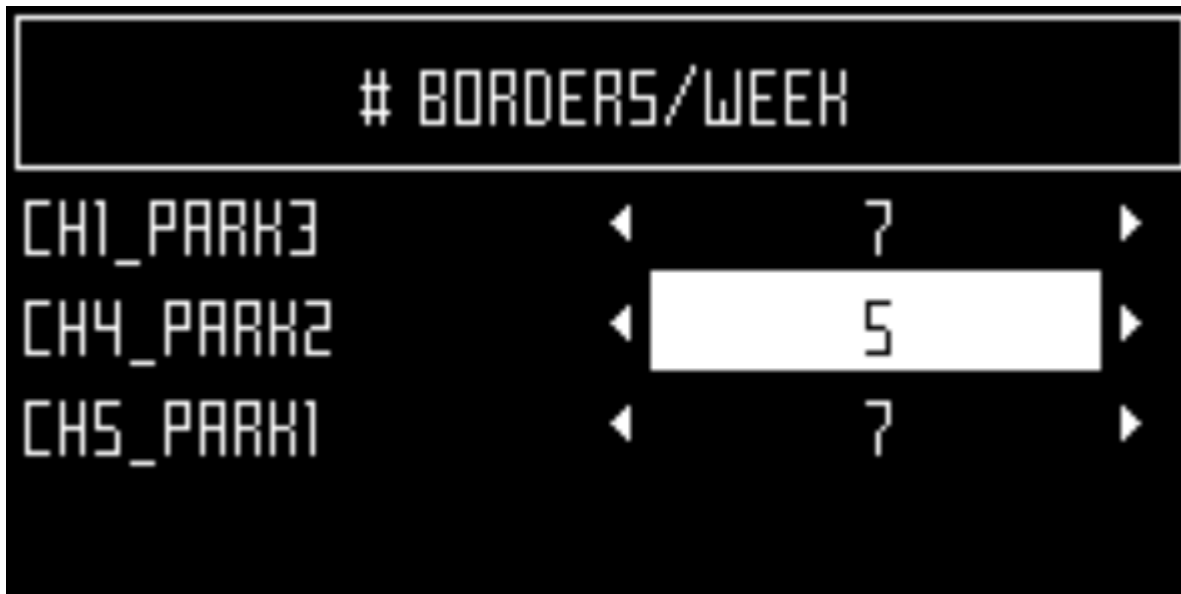
1. Press .
2. Press the up  and down  arrows to highlight Border then press . A screen will appear with a list of configured working parcels.



G525123

3. Highlight the parcel, then use the left and right arrow keys to scroll to the required number of border modes per week.
4. Press .
5. Press  to return to the main menu.

Cutting Height

This command allows you to set height of the blades and to disable mowing in a specific parcel.





When using the robot for the first time in the season or after being switched off for several days, the grass may be too dense or too long, and it will be necessary to increase the mowing height for a few days. By default, the cutting heads will rise automatically when an increased resistance from long, dense grass is detected. The cutting heads will also be lowered when the resistance has decreased.

The height of the blades can be defined for each parcel in which the robot is going to work. The parcel in which the robot is currently located is termed the actual parcel.

Note: If the cutting height is set to 25 mm (0.98 in) or less, this will result in increased wear of the white plastic cover of the anti-friction disc. In this case, this part should be inspected frequently (at least every 2 months) and replaced if necessary.

Overview of the Menus (continued)

Setting the Cutting Height

1. Press .
2. Press the up  and down  arrows to highlight Cutting height, then press .

Note: A screen appears, which shows the cutting height in the parcel in which the robot is located.



G525124

Note: If this value is negative, it implies that a reset of the parameters has taken place and that the blade height values need to be re-calibrated.

3. Click Set target . A list of configured parcels and their cutting heights are displayed. In this example it can be seen that the Active parcel is LOOP.

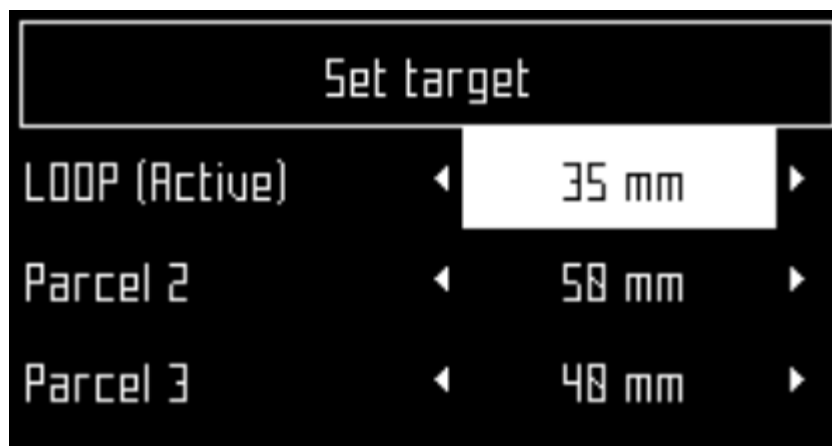

G525125

4. Highlight the parcel in which the cutting height is to be modified, then use the left and right arrow keys to scroll to the required value. Press  to set the new height.

Overview of the Menu (continued)

Note: If the height for the Active parcel is modified, the cutting heads will be raised or lowered. If the height is modified in one of the other parcels, the cutting heads will be raised or lowered when the robot enters the parcel.

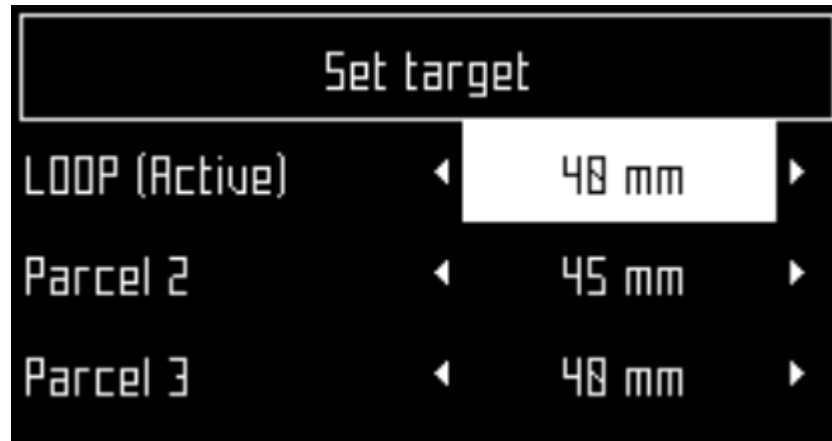

G525126

5. Repeat for other parcels.
6. Press **X** to return to the main menu.

Note: The new height for the active parcel is displayed.



G525127

Disabling Mowing in a Specific Parcel

This is useful if there are parcels where there is no grass, such as a loop parcel, or a connecting parcel between two grassy areas. When the robot enters this parcel, the cutting heads are deactivated and the cutting height is set to the maximum cutting height for all configured parcels.

Note: If the machine should be scheduled to work on a parcel on which the cutting heads are disabled, the machine will operate on this parcel but the cutting heads will not be active.

1. Follow the instructions given above to open the Cutting Height screen.
2. Click Set Target.
3. Highlight the parcel where mowing is not required. Scroll through the values using the right/left arrows and select Disabled.

Overview of the Menus (continued)

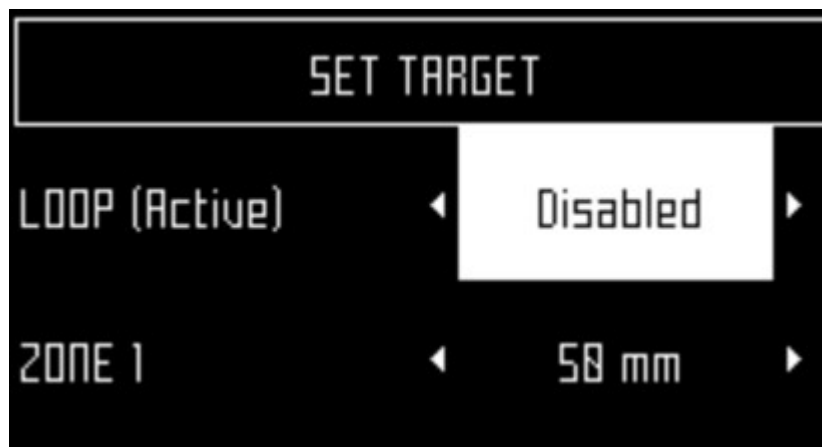

G525128

4. Press **X** to return to the main menu.

LCD Settings

Modifying the LCD Settings

1. Press **⚙** for a few seconds.

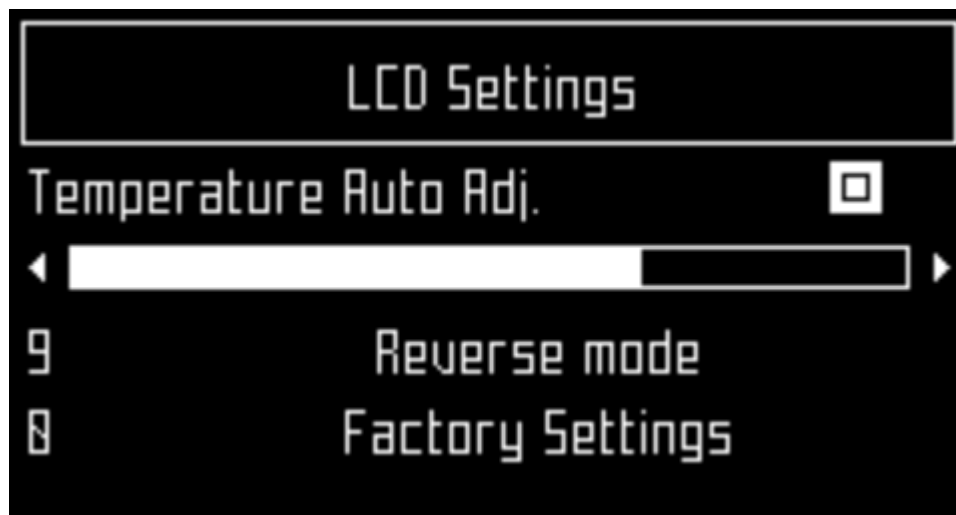

G525132

2. Press the right **▶** and left **◀** arrow buttons to change the contrast.
3. Press the up **▲** and down **▼** arrows to highlight Temperature Auto Adj. When this option is checked ON, the LCD contrast is automatically adjusted according to the ambient temperature. Press **☑** to check or uncheck this option.
4. Press the 9 key to invert the colors black and white.
5. Press the 0 key to revert to the factory settings.
6. Press **X** to exit this menu.

Overview of the Menu (continued)

Service Settings Menu

Service Settings menu

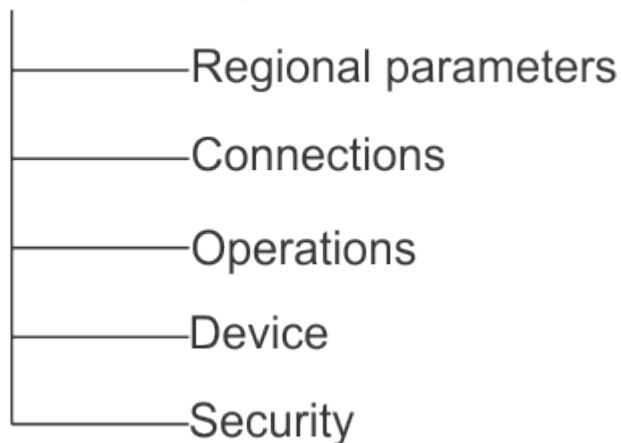

G525136

Regional Parameters

This menu enables you to set the date format, the robot time zone, the language used in the menus and the unit system.

Date format

The date format can be set to be DD/MM/YYYY (Day/Month/Year) or MM/DD/YYYY (Month/Day/Year).

Time zone

Use the left and right arrow keys to scroll to the required time zone.

Language

Use the left and right arrow keys to select the required language.

Unit system

Use the left and right arrow keys to select the required unit system. The unit of any displayed value is shown.

Connections

It is necessary to connect with the robot for the following reasons:

- Enabling the robot to communicate with the portal on the web-server allows users to monitor the state of the robot.
- Updating the robot software version allows the robot to connect with the remote server on a regular basis to check if a new software version is available. If an update is available, the robot starts to download it as a background task while it continues to work

Overview of the Menu (continued)

as usual. At the end of the next charging period, the newly downloaded software will have been installed on the robot.

IP address

This displays the current IP address of the robot, depending on the mode in which the robot is operating. Modes include mobile, vpn, and WiFi.

Mode

Allows you to set the mode in which the robot is to operate. This can be OFF, Client, Access point, Search for networks, and SSID.

OFF

The robot will not be connected to a network

Client

The robot will connect to the selected network as a client.

Access point

The robot will use its inbuilt modem to generate its own WiFi network to which you can connect.

Search for networks

This option appears when the robot is not connected or cannot detect a WiFi network.

SSID

This displays the name of the WiFi network to which the robot is connected, and allows you to modify it. Highlight {network name} and press .

A list of networks appears.

Network Overview

- Entries in bold text are ones that the robot has connected to.
- Entries in normal text are available but which have not been used.
- [*] indicates the actual network to which the robot is connected.
- [!] indicates that the network to which the robot is connected, is not encrypted using either WPA or WPA2 technologies. This is therefore an insecure network and the [!] indicates a warning.
- [-] indicates that the network has been disabled.

Overview of the Menus (continued)





Connecting to a Different Known Network

1. To connect to a different known network, highlight the network, press , and select **Enable Network**.
2. To modify the current network, highlight the network and press . The following operations are available:
 - **Disable Network:** disconnects the robot from this network. This will be indicated by [-] preceding the name of the network in the list.
 - **Change Password:** allows you to modify the password to access the network from this machine.
 - **Forget Network:** removes the recognition of this known network from this robot.

Overview of the Menus (continued)

Using the Robot as a Client

For normal operation, it is recommended that you set up the robot as a WiFi client. This will enable it to communicate with the portal on the web-server.

1. Press .
2. Highlight Connections and press .
3. Highlight Mode and set it to Client. If the robot has not been connected to a WiFi network, selecting the option Search for networks will search for networks and present a list of those available.
4. Highlight the WiFi network required and press .
5. Enter the password for the network using the keyboard.
6. Highlight V and press .

Operations

This menu enables you to set a number of operating parameters:

Min temp

Sets the lowest temperature that the robot will operate at.

Note: Working at too low a temperature can damage the grass.

Edit parcels percentage

This option enables you to view and modify the percentage values assigned to each of the parcels that have been defined. The percentage value assigned to a parcel determines the proportion of times the robot will start working in the parcel. A defined schedule for the robot to work in specific parcels will take priority over these percentage values.

Brake on idle

When this option is checked ON, at least one brake will be applied when the robot is stationary. This ensures that the robot does not slide down a slope if:

- the robot has stopped because of an alarm
- the user has manually stopped the robot
- the stop cover lid is open

If the brakes have been applied due to this option, you can disable them (or re-enable them again) by pushing 5. The brakes will also be released when the robot starts to work again normally.

This option need **not** be set if the working terrain is flat, and it is set OFF by default.

Overview of the Menus (continued)

Max short cycles allowed







This parameter sets the maximum number of times that the robot will return to the station, after executing a very short cycle, before triggering an alarm.

Device

This menu displays the characteristics of the device and enables you to change the robot's name.

Changing the Robot Name





By default the name of the robot corresponds to the serial number.

1. Press .
2. Press the arrow keys to highlight `DEVICE INFO` then press .
3. Highlight `ROBOT NAME` and press .
4. Highlight the back arrow to delete the current name.
5. Use the alpha-numeric keyboard to enter the new name. Highlight each character required and press  to select it.
6. Highlight `V` in the bottom row and press .
7. Press  to accept the new name.
8. Press  to return to the main menu.

Activation Code

The activation code is a four-figure code provided on the registration card supplied with each robot.

Accessing Device Info

1. Press .
2. Press the arrow keys to highlight `DEVICE` then press .
3. Highlight `DEVICE INFO` and press .
4. Use the arrows ,  to scroll through the list.

Device Info Options

Robot name

The name of the robot.

Overview of the Menus (continued)

Serial number

Serial number of the robot.

Latitude

Current latitude of the robot position.

Longitude

Current longitude of the robot position.

Visible satellites

Number of satellites that the device can currently detect.

APN

Id. of the Access Point Network.

MAC Address

MAC address.

System Version

Software version

The current software version.

- Details

Brain version

Current Artificial Intelligence (AI) version. Use this when reporting a problem.

- Bootloader details

This displays a list of software components. The values displayed here should be used when reporting a problem.

- Firmware details

This displays a list of software components. The values displayed here should be used when reporting a problem.



Maintenance Overview

- Maintenance refers to a set of tasks that should be carried out regularly throughout the mowing season.
- The service interval depends to some extent on the operational load of your robot, but it is recommended that it is serviced by an authorized technician at least once a year.
- Whilst maintaining your robot for optimum performance, do not attempt to make any changes to your robot. You risk disturbing its operation, causing an accident, and damaging parts.

Note: If you notice any unusual behavior or damage, call a technician.

- When carrying out these maintenance procedures the following safety regulations should be observed:
 - Stop the machine: Always switch off the power and wait for the all moving parts to stop before handling the machine.
 - Operate the disabling device before the following:
 - ◆ Before working on or lifting the machine.
 - ◆ Before clearing a blockage.
 - ◆ Before checking, cleaning or working on the machine.
 - ◆ After striking a foreign object to inspect the machine for damage.
 - ◆ If the machine starts to vibrate abnormally.
 - ◆ Keep all nuts, bolts, and screws tight to be sure the machine is in safe working condition.
 - ◆ Use gloves: Protective gloves must be worn whenever handling the machine.
 - ◆ Always use OEM (Original Equipment Manufacturer) parts. In addition to the risk of accidents, the use of any non-OEM parts will result in the annulment of the guarantee for any resulting damage.

Recommended Maintenance Schedule

Note: These procedures should be carried out at the recommended frequency by the regular user of the robot.

Note: Throughout the mowing season, you should regularly check that all screws, nuts, and bolts are properly tightened. Tighten any that are loose, and if there is damage or evidence of a problem, contact an authorized Toro distributor.

Maintenance Service Interval	Maintenance Procedure
Before each use or daily	Regular cleaning (during wet weather)
Every 40 hours	Clean the charge contacts
	Cleaning the sonar sensors
	Clean the front wheels
	Clean the front wheel axle
	Cleaning the cutting head
	Inspect the cutting unit
	Clean the rear wheels
Every 6 months	Check the wiring
	Replace the cutting blades
Yearly or before storage	Battery service
	Storage

Pre-Maintenance Procedures

Preparing for Maintenance

1. Turn off the machine by pressing and holding the  button on the keypad for a few seconds.
Note: At the end of the working season, the main power switch of the machine should be switched off.
2. Remove the body shell.
 - A. Lift the body shell to disconnect it from the chassis at any of the attachment points.
 - B. Repeat this for the other attachment points in sequence.
 - C. Lift the entire body shell off of the chassis.

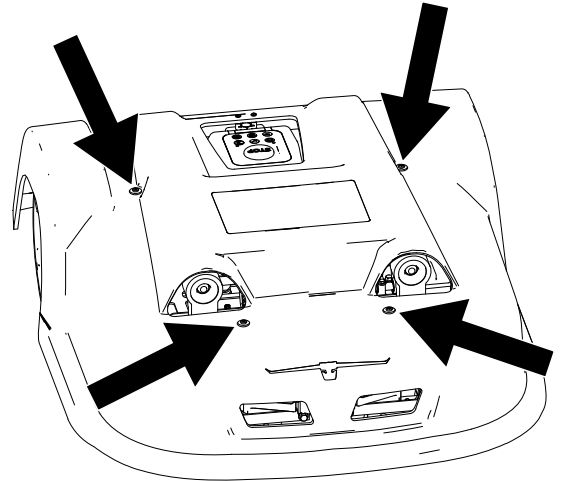

G593372

3. Using the handle at the front of the machine, lift the machine and stand the machine on its rear.

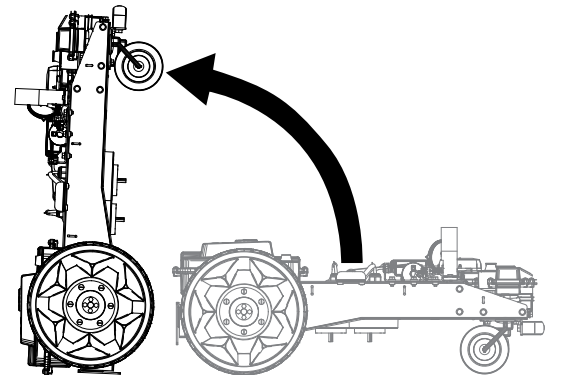

G594713

Cutting Unit Maintenance

Inspecting the Cutting Unit

Inspect the blades, blade bolts, and cutting-disc assembly each week to maintain the proper cutting function.

Replacing the Cutting Blades

The condition of the cutting blades is essential for a satisfactory mowing operation. The service life of the blades depends on a number of factors. Parts for the cutting-disc assembly should be replaced whenever they are damaged.



WARNING



The blades are sharp; contacting the blades could result in death or serious injury. Use care when replacing or cleaning the blades.

1. Prepare the machine for maintenance.
2. Rotate the disc ^① so that the holes align with the blade screws ^②.
3. Remove the blades by removing the screws ^③.
4. Install the new blades ^④ and torque the screws to **2 N·m (17 in-lb)**.



Note: Orient the blades so that the washers touch the surface of the disc ^⑤.

Note: After any intervention with the cutting heads, rotate each of them independently and verify that rotating one does not cause the others to rotate.

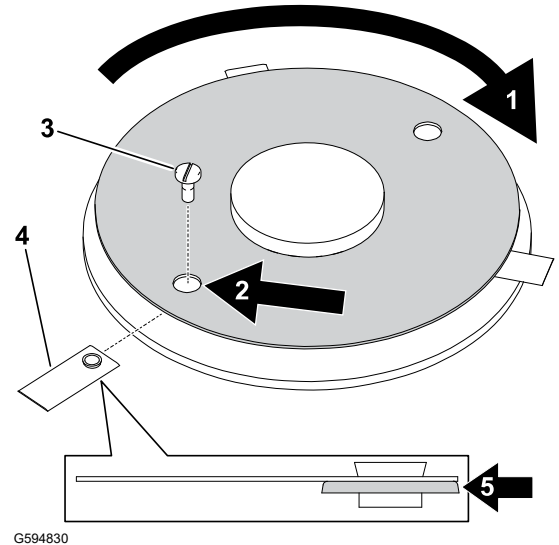

Cleaning

Cleaning the Machine

During periods of wet weather it is necessary to ensure that mud and grass do not accumulate on the moving parts, which are the wheels and the cutting heads. These should be inspected and cleaned daily.

1. Prepare the machine for maintenance.
2. Remove any accumulations of grass and dirt using a blower, compressed air, and/or a wire brush.
3. Rub the body with a soft, damp cloth or sponge.
4. If the body is very dirty, use a soapy solution.

IMPORTANT

Never use solvents.

Cleaning the Charge Contacts

1. Prepare the machine for maintenance.
2. Rub the charge contact surfaces with fine-grade sandpaper (120 grade or higher) until they appear clean.

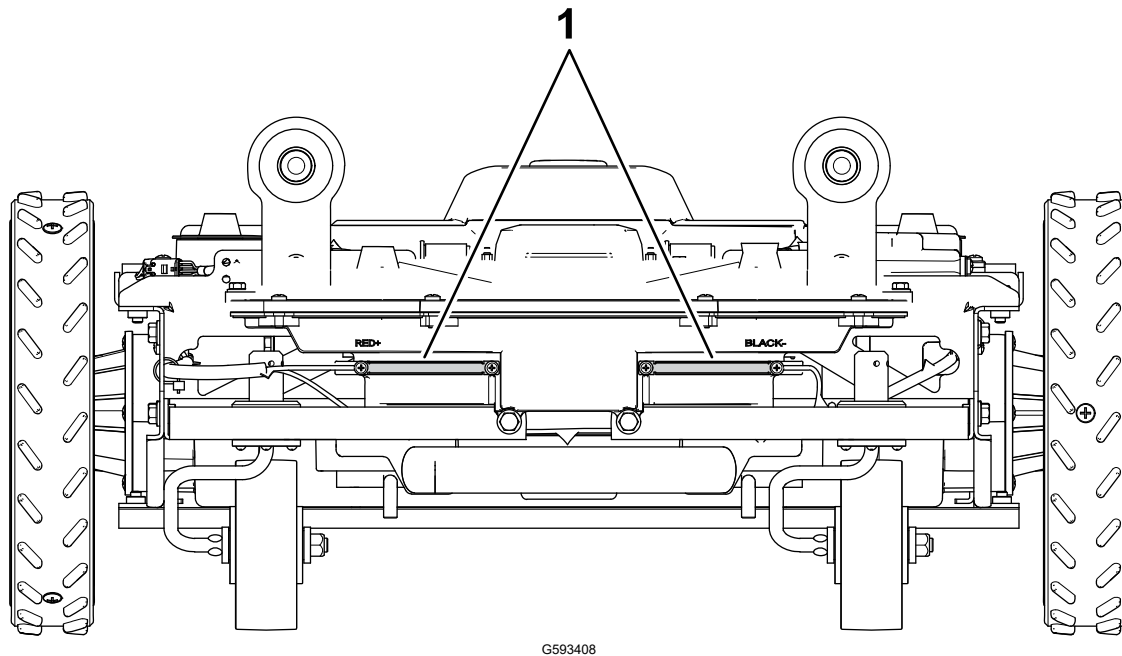

G593408

① Charge contacts

Cleaning the Sonar Sensors

The sonar sensors need to be kept clean if they are to operate properly. All sensors need to work properly. If any of the sensors are not operating properly, an alarm is issued.

Remove any mud, grass, or dirt from the sonar sensors ①, and wipe with a damp cloth.

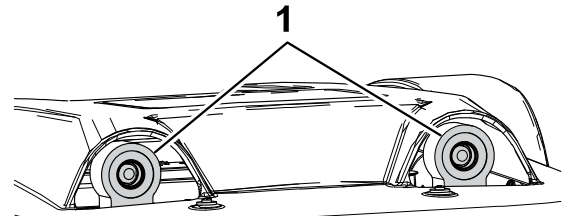

G594714

IMPORTANT

Do not use water to clean the sensors.

Cleaning the Front Wheels

1. Remove any mud and grass with a wire brush or a cloth.

Cleaning the Front Wheels (continued)

2. Check that the wheels rotate easily and that there is not too much play. If there is too much play, replace the wheels.

Cleaning the Front Wheel Axles

1. Clean the front wheel axles with a brush and/or a cloth.
2. Visually inspect the axles. If there is a problem, replace the axles.

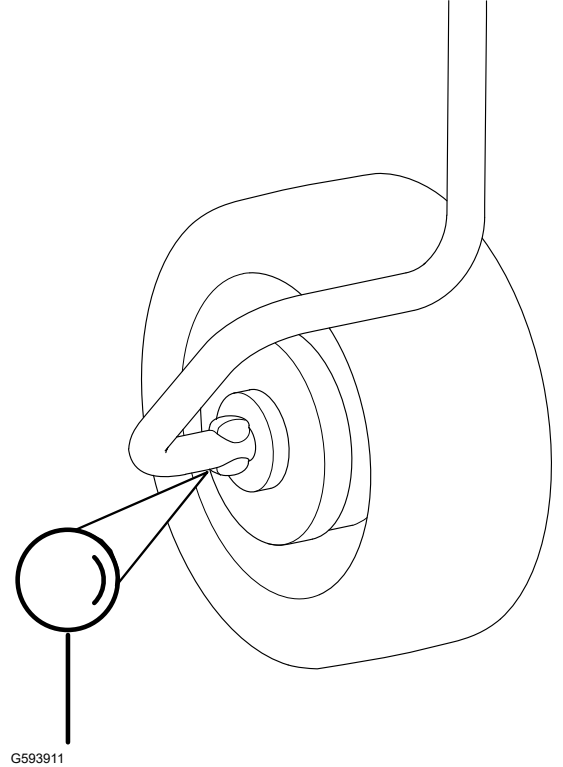

G593911

Cleaning the Cutting Head

1. Prepare the machine for maintenance.
2. Clean the cutting head using a brush. If compressed air is available, this is preferable.
3. Ensure that the entire cutting head moves smoothly backward and forwards.

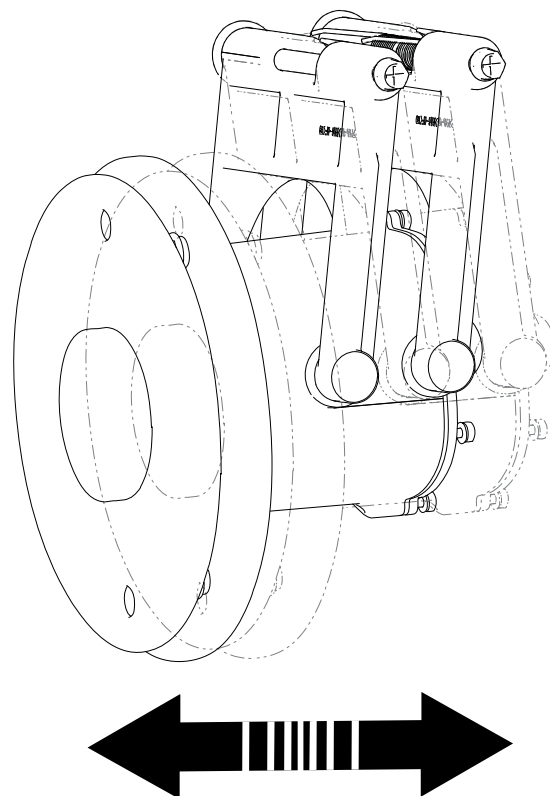

G593451

Cleaning the Cutting Disc

This procedure should be performed weekly. This is important if the cutting height is set to 25 mm (1 inch) or less. If this is the case, the wear on the anti-friction disc is increased and may need to be replaced at least every 2 months.

1. Prepare the machine for maintenance.
2. Clean the cutting disc using a brush. If compressed air is available, this is preferable.
3. Ensure that the cutting disc rotates smoothly. If there is a problem, replace the cutting discs.

Cleaning the Rear Wheels

Remove any mud and grass using a wire brush.

Electrical System Maintenance

Checking the Wiring

1. Prepare the machine for maintenance.

Checking the Wiring (continued)

2. Visually inspect the wiring under the robot. If any problems are detected, contact an authorized Toro distributor.

Battery Service

The automatic (programmed) operation of the robot optimizes battery life. It is advisable to allow the robot to manage its working cycles. If these work cycles seem unusually short, contact an authorized Toro distributor to check the condition of the battery.

Note: It is possible to monitor these cycles using the portal.



Storing the Machine

1. Fully charge the machine.
2. Turn off the machine using the power switch.
3. Clean the machine.
4. Store the machine in a dry, protected, and frost-free environment.

Note: Protect the charging station with a shelter or a tarpaulin.
It is not necessary to turn off the charging station.







Removing the Machine from Storage

1. Turn on the machine using the power switch.
2. Ensure that the charging station is connected to power.
3. Check the battery voltage for the machine.

Note: The battery voltage can be seen under the **Technician menu > Sensors data > Energy**.

4. Start the machine and verify that it returns to the charging station.



	Your robot meets European standards.
	Recycle: Waste electrical and electronic equipment is subject to selective collection. Please recycle your robot according to the standards in force.
Icons on the battery	
	Make sure you are familiar with the documentation before handling and using the battery.
	Do not allow the battery to come into contact with water.
	Caution—Take care when handling and using the battery. Do not crush, heat, incinerate, short circuit, dismantle, or immerse in any liquid. Risk of leakage or rupture. Do not charge below 0°C (32°F). Only use the charger specified in the user's manual.
 Li-Fe	Recycle your battery. Refer to the user's manual for battery recycling instructions.
	Indicates the battery polarity.



Abbreviations

APN	Access Point Name (GSM)
BMS	Battery Management System
LFP	Lithium Ferrous Phosphorous
UWB	Ultra Wide Band
CPU	Central Processing Unit
GPS	Global Positioning System
AP	Access Point (WiFi)
RTK	Real Time Kinematic
GNSS	Global Navigation Satellite System
PoE	Power over Ethernet
RTCM	Radio Technical Commission for Maritime Services (a Real-Time GNSS Data Transmission Standard)



Border mode

When the robot cuts the grass at the very edge of the field. This is done a number of times per week.

Cycle

A cycle is a working session of the robot. It starts when the robot leaves the station and ends when it returns to the station or there is an problem that halts the working cycle.

Entity

A collection of robots and users that operate within a site. Information about the robots in an entity can be viewed on the web portal.

GPS return point

A specific point within a parcel that the robot uses to return to or leave a station. The point is defined by its latitude and longitude. The robot takes a direct route to this point then follows the track border and the loop wire to return to the station.

Idle

A robot will enter idle mode if the current mission has been ended using the Stop button. By default the robot will enter the sleep mode after 15 minutes.

Internal GPS zone

An internal GPS zone is defined by set of GPS coordinates. It allows a wireless or wired parcel to be subdivided without having to use additional wires and channels.

This provides greater flexibility in defining working areas since the robot can be scheduled to work with optimum efficiency over the different areas.

Island

A loop in the peripheral wire specially installed to prevent the robot working inside it. The peripheral wire is taken around the obstacle and the approach and return wires laid next to each other.

Map

Map of the robots routes on the portal.

Mapping

The information built up by the robot using GPS data.

NoGo zone (exclusion zone)

GPS-defined NoGo zones (exclusion zones) are regions on the field defined by GPS coordinates that the robot shall not enter. NoGo zones are used to exclude zones from the working area of the robot that cannot be detected during border discovery. Use of NoGo zones allows the robot to calculate the most efficient mowing pattern in advance. NoGo zones are used to exclude obstacles, typically done by islands and pseudo islands.

Obstacle

An object or ground condition which can cause harm, or is harmed, if it comes into contact or collision with the machinery. Obstacles can be permanent (e.g., trees, furniture) or transitory, (e.g., animals). Obstacles are detected by sensors. Permanent obstacles can be avoided by making loops in the peripheral wire to form "islands" or "pseudo-islands".

Parcel

An area to be mowed within a GPS zone or a peripheral wire. At least one parcel is associated with one zone or wire. Several parcels can be defined.

Percentage

This represents the proportion of time that the robot will spend working a particular parcel. If there is only one parcel, the robot will spend 100% of its time there.

Peripheral wire

A wire laid below the surface of the field which defines the area in which the robot works. The area defined by the peripheral wire is termed a "parcel".

Pseudo-island

The peripheral wire is taken around the obstacle, maintaining a specific distance between the approach and the return wires.

Robot status values

- Off
Robot has been switched off.
- Off after alarm
Robot has switched itself off after an alarm.
- Alarm
Robot is in a state of alarm.
- Staying
Robot is waiting at a charge station.
- Charge

Robot status values (continued)

Robot is charging the battery.

- Heading for unload station

Robot is going to the drop pit station to unload balls. This status starts when a robot decides to return to the station.

- Heading for charge station

Robot is going to the charging station. This status starts when the robot decides to return to the station.

- Leaving station

Robot is leaving the station and starting to work.

RTK GPS zone

The working area for a robot performing pattern mowing. The RTK GPS zone is defined by the robot making a tour of the peripheral wire.

Site

The entire area which includes the area in which the robot works.

Sleep

A robot will enter sleep mode 15 minutes after an alarm has occurred which has not been cleared. After 2 days in sleep mode, the robot will enter OFF mode. This will also occur if the battery charge level reaches a low level. When in sleep mode the robot uses minimal power to reduce the risk of the battery.

The robot can be brought out of sleep mode by:

- Clearing the alarm and switching the robot on, using the button on the LED screen
- Pushing the robot to the charging station, if the battery is out of energy
- Sending a remote wakeup command via the web portal

Station loop wire

A station loop is a short wire around a charging station which is used to guide the robot into the station. When the robot detects that it is in the station loop, it follows the wire until it arrives in the station.

Terrain

An area of grass surrounding the field that is not to be mowed.

Track border

A width of grass around the edge of the parcel in which the robot works. The robot follows the track border when leaving or returning to a station, unless it is using GPS. There is no track border specified for a wire that acts as a station loop wire.

Track border (continued)

Track border

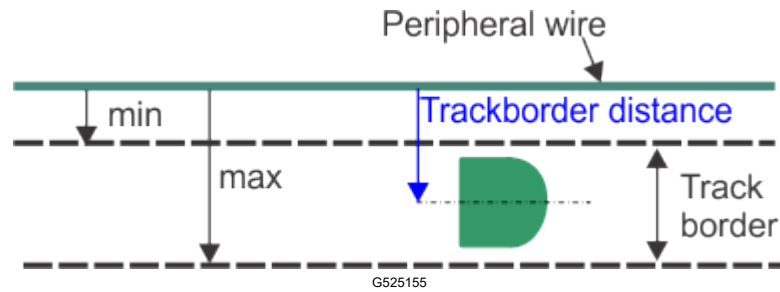

The track border lies next to the peripheral wire, and is defined by minimum and maximum dimensions set as installation parameters. It is wider than the robot. The path taken by the robot within the track border is selected in a random manner. This ensures that the robot does not repeatedly move along the same path and so create ruts in the field. If the robot encounters an obstacle whilst in the track border, the sensors will cause it to reverse and then rotate through a random angle in order to proceed. This may be repeated a number of times if necessary.

Maneuvers to avoid an obstacle within the track border

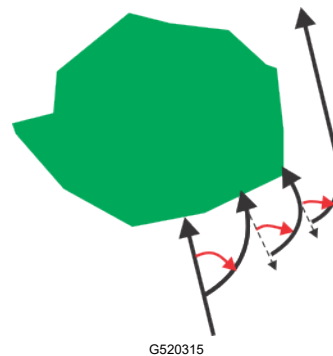

Working Area

An area inside of a boundary in which the robot can run autonomously. This is an RTK GPS zone that is defined by the border discovery process. Sub-zones can then be created by copying and editing this zone to optimize the efficiency of the robot.

California Proposition 65 Warning Information

What is this warning?

You may see a product for sale that has a warning label like the following:



WARNING: Cancer and Reproductive Harm—www.p65Warnings.ca.gov.

What is Prop 65?

Prop 65 applies to any company operating in California, selling products in California, or manufacturing products that may be sold in or brought into California. It mandates that the Governor of California maintain and publish a list of chemicals known to cause cancer, birth defects, and/or other reproductive harm. The list, which is updated annually, includes hundreds of chemicals found in many everyday items. The purpose of Prop 65 is to inform the public about exposure to these chemicals.

Prop 65 does not ban the sale of products containing these chemicals but instead requires warnings on any product, product packaging, or literature with the product. Moreover, a Prop 65 warning does not mean that a product is in violation of any product safety standards or requirements. In fact, the California government has clarified that a Prop 65 warning “is not the same as a regulatory decision that a product is ‘safe’ or ‘unsafe.’” Many of these chemicals have been used in everyday products for years without documented harm. For more information, go to <https://oag.ca.gov/prop65/faqs-view-all>.

A Prop 65 warning means that a company has either (1) evaluated the exposure and has concluded that it exceeds the “no significant risk level”; or (2) has chosen to provide a warning based on its understanding about the presence of a listed chemical without attempting to evaluate the exposure.

Does this law apply everywhere?

Prop 65 warnings are required under California law only. These warnings are seen throughout California in a wide range of settings, including but not limited to restaurants, grocery stores, hotels, schools, and hospitals, and on a wide variety of products. Additionally, some online and mail order retailers provide Prop 65 warnings on their websites or in catalogs.

How do the California warnings compare to federal limits?

Prop 65 standards are often more stringent than federal and international standards. There are various substances that require a Prop 65 warning at levels that are far lower than federal action limits. For example, the Prop 65 standard for warnings for lead is 0.5 µg/day, which is well below the federal and international standards.

Why don't all similar products carry the warning?

- Products sold in California require Prop 65 labelling while similar products sold elsewhere do not.
- A company involved in a Prop 65 lawsuit reaching a settlement may be required to use Prop 65 warnings for its products, but other companies making similar products may have no such requirement.
- The enforcement of Prop 65 is inconsistent.
- Companies may elect not to provide warnings because they conclude that they are not required to do so under Prop 65; a lack of warnings for a product does not mean that the product is free of listed chemicals at similar levels.

Why does Toro include this warning?

Toro has chosen to provide consumers with as much information as possible so that they can make informed decisions about the products they buy and use. Toro provides warnings in certain cases based on its knowledge of the presence of one or more listed chemicals without evaluating the level of exposure, as not all the listed chemicals provide exposure limit requirements. While the exposure from Toro products may be negligible or well within the “no significant risk” range, out of an abundance of caution, Toro has elected to provide the Prop 65 warnings. Moreover, if Toro does not provide these warnings, it could be sued by the State of California or by private parties seeking to enforce Prop 65 and subject to substantial penalties.

Notes:

