



13-32H Rear-Engine Riding Mower

Model No. 70186 - 240000001 and up.

Parts Catalog

Ordering Replacement Parts

To order replacement parts, please supply the part number, the quantity, and the description of each part desired.

Understanding Reference Numbers

Each Identified part in an illustration has a reference number. The reference number for a part also appears in the parts list, along with other information about the part.

This catalog uses two special reference number formats, one to indicate parts in a service assembly and another to indicate the quantity of a given part in an illustration.

Service Assembly Reference Numbers

Parts in service assemblies have reference numbers in the form a:b. The a represents the reference number of the entire service assembly and the b represents a sequential number unique to each part within the service assembly.

For example, a wheel assembly might be identified by reference number 6, the tire by 6:1, the valve by 6:2, and the wheel by 6:3. When you order the assembly identified by reference number 6, you receive all parts identified by reference numbers 6:1, 6:2, and 6:3. However, you may also order any part individually. Reference numbers of this type appear in illustrations and in part lists.

Reference Numbers Indicating Quantity

In an illustration, if a reference number indicates more than one part, the reference number has the form nX y. The n represents the quantity of the part, the X is the multiplication symbol, and the y represents the reference number.

For example, in an illustration, the reference number 2X 37 means that two of the parts identified by reference number 37 are indicated.

Contents

Description	Page	Description	Page
Body and Decal Assembly 3	Oil Filter, Tube and Pump Assembly Briggs and Stratton 31G777-0121-E1 18
Seat and Rear Bag Assembly 4	Crankcase Assembly Briggs and Stratton 31G777-0121-E1 19
Front Axle and Steering Assembly 5	Carburetor Assembly Briggs and Stratton 31G777-0121-E1 20
Deck and Spindle Assembly 6	Governor Assembly Briggs and Stratton 31G777-0121-E1 21
Deck Suspension Assembly 8	Blower Housing Assembly Briggs and Stratton 31G777-0121-E1 22
Rear Wheel and Transmission Assembly 9	Starter Assembly Briggs and Stratton 31G777-0121-E1 23
Hydro Transaxle-Assembly No. 106-1840 10	Gasket Assembly Briggs and Stratton 31G777-0121-E1 24
Hydro Transaxle-Assembly No 106-1840 (continued) 11	Carburetor Overhaul Kit Assembly Briggs and Stratton 31G777-0121-E1 25
Hydro Transaxle-Assembly No. 106-1840 (continued) 12		
Engine and Fuel Tank Assembly 13		
Electrical and Cable Assembly 14		
Cylinder Assembly Briggs and Stratton 31G777-0121-E1 15		
Cylinder Head Assembly Briggs and Stratton 31G777-0121-E1 16		
Crankshaft Assembly Briggs and Stratton 31G777-0121-E1 17		

Part Description Abbreviations

Part descriptions in this catalog may include the following abbreviations.

AR. as required	INC. incorporated
ASM. assembly	LH. left hand
CARR. carriage	NI. nylon insert
DEG. degrees	PPH. phillips pan head
FH. flat head	PTH. phillips truss head
GA. gauge	PTO. power take off
HF. hex flange	RH. right hand
HH. hex head	SFH. slotted fillister head
HHF. hex head flange	SHH. slotted hex head
HHFTF. hex head flange thread forming	SHWH. slotted hex washer head
HJ. hex jam	SPH. slotted pan head
HLH. hex lag head	SQH. square head
HOC. height-of-cut	SRH. slotted round head
HS. hex	STD. standard
HSBH. hex socket button head	TAP. self tapping
HSFH. hex socket flat head	TTH. torx truss head
HS. hex socket head	WH. wing head
HWH. hex washer head	
HWHTF. hex washer head thread forming	
HYD. hydraulic	

Footnotes

- | | |
|--|---|
| <ul style="list-style-type: none"> ❶ Not illustrated ❸ Included in Engine Gasket Set-Ref. 358. ❺ Included in Carburetor Overhaul Kit-Ref. 121. ❻ Obtain parts from your local Briggs & Stratton dealer | <ul style="list-style-type: none"> ❷ Not serviced separately ❹ Included in Valve Gasket Set-Ref. 1095. ❻ Included in Carburetor Gasket Set-Ref. 977. ❼ Included in Decal Kit 106-2887 |
|--|---|

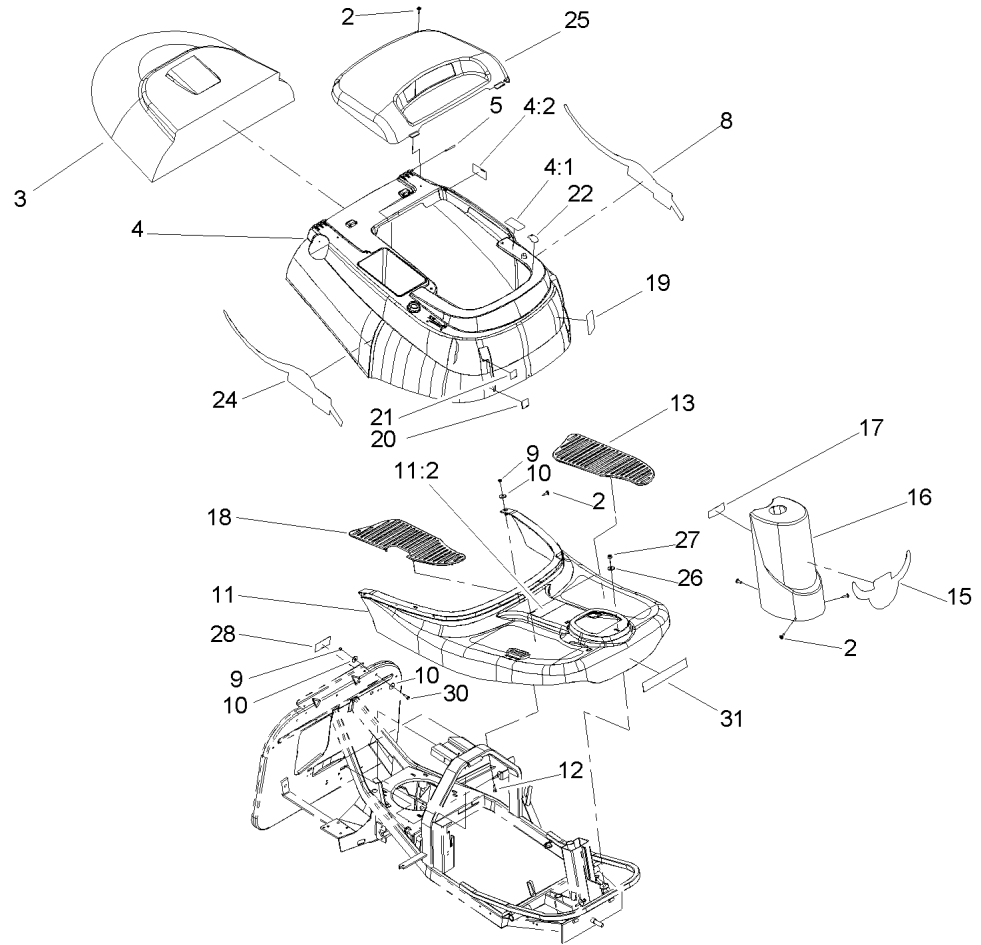

Body and Decal Assembly

Ref	Part No.	Qty.	Description
2	106-2851	11	Screw-Hh, TAP
3	106-1810	1	Cover-Grass Bag
4	106-2885	1	Shroud And Decal ASM
2 3 4:1		1	Decal-Danger
2 3 4:2		1	Decal-Warning, Hot
5	106-2870	2	Pin-Dowel
8	106-6502	1	Decal-Side, Left
9	49-7810	5	Nut-Lock
10	106-2853	4	Washer-Flat
11	106-2901	2	Foot Rest And Decals ASM
2 3 11:2		1	Decal-Caution
12	33113-020	2	Screw-HH
13	106-2973	1	Floormat-LH
15	106-6517	1	Decal-Front
16	106-2906	1	Steering-Turret
2 3 17		1	Decal-Run Lights
18	106-2972	1	Floormat-RH
2 3 19		1	Decal-HOC
2 3 20		1	Decal-Pto, Disengage
2 3 21		1	Decal-Pto, Engage
2 3 22		1	Decal-Switch
24	106-6503	1	Decal-Side, Right
25	106-2860	1	Cover-Engine
26	106-2854	1	Washer-Flat

Ref	Part No.	Qty.	Description
27	46-0330	1	Nut-Lock
2 3 28		1	Decal-Disengagement
30	33113-016	2	Screw-HH
31	106-6525	1	Decal
1 99	106-2887	1	Decal-Kit

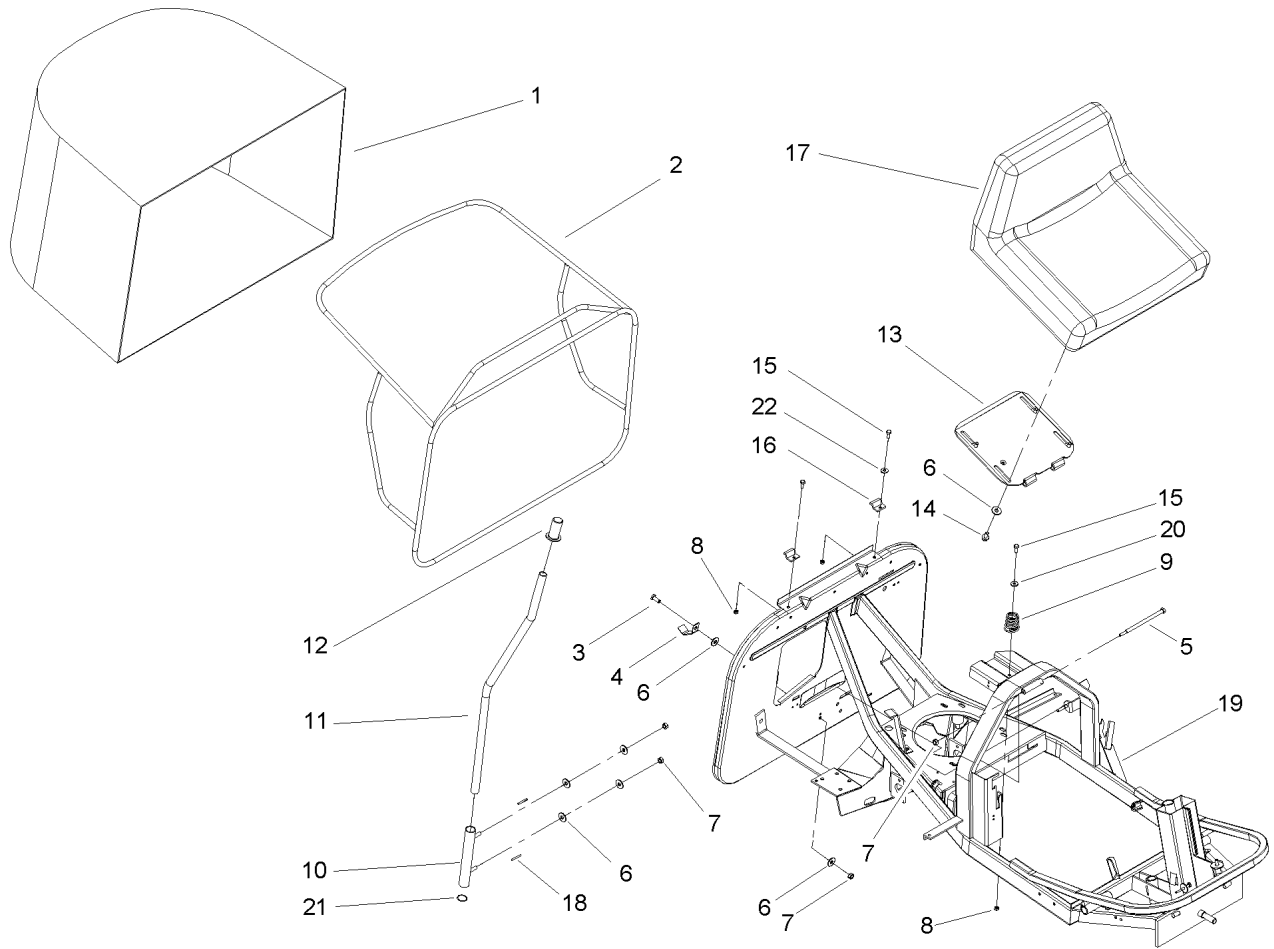

Seat and Rear Bag Assembly

Ref	Part No.	Qty.	Description
1	106-2867	1	Bag-Grass
2	106-2924	1	Frame-Bag
3	33114-020	1	Screw-HH
4	106-2969	1	Hook-Bag
5	106-1844	1	Screw-HH
6	106-2854	2	Washer-Flat
7	46-0330	2	Nut-Lock
8	49-7810	1	Nut-Lock
9	106-2945	1	Spring-Compression
10	106-2927	1	Support
11	106-2928	1	Lever
12	106-2903	1	Knob
13	106-2944	1	Plate-Seat
14	33104-016	4	Screw-HHF
15	33113-016	1	Screw-HH
16	106-2929	2	Clip
17	106-2857	1	Seat
18	106-2871	2	Pin-Spring
19	107-2238	1	Frame
20	106-2865	3	Washer-Flat
21	106-1807	1	Spacer
22	106-2853	2	Washer-Flat

--	--	--	--

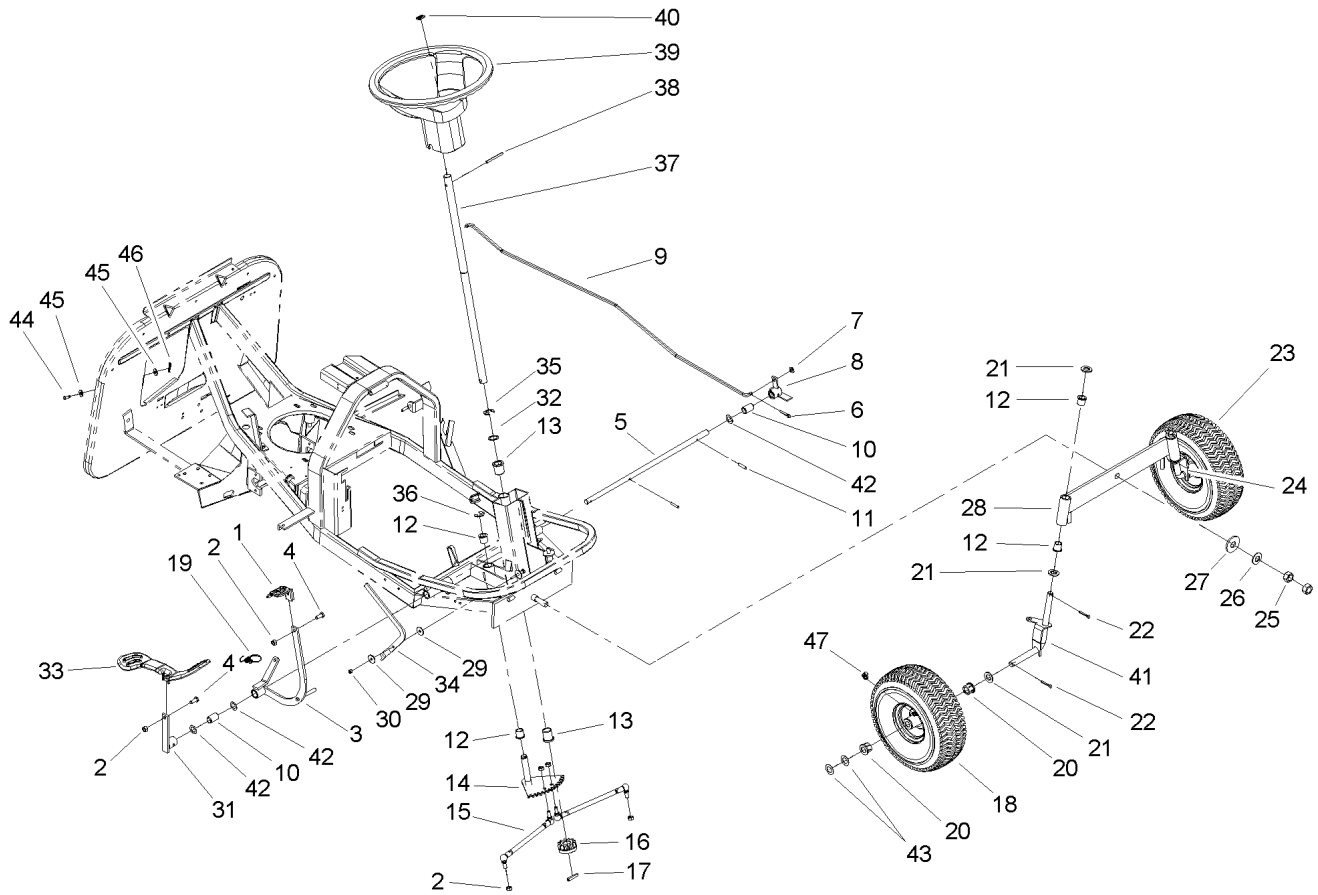

Front Axle and Steering Assembly

Ref	Part No.	Qty.	Description
1	106-2957	1	Pedal-Brake
2	46-0330	6	Nut-Lock
3	106-2965	1	Lever-Brake
4	33114-020	2	Screw-HH
5	106-2959	1	Shaft
6	3272-21	2	Pin-Cotter
7	33094-00	2	Washer-Flat
8	106-2960	1	Bushing
9	106-2963	1	Rod
10	106-2962	2	Bushing
11	106-2874	3	Pin-Dowel
12	106-1811	6	Bushing
13	106-2873	2	Bushing
14	106-2868	1	Rack-Steering
15	106-2933	2	Rod-Tie
16	106-2878	1	Gear-Steering
17	106-1845	1	Pin-Spiral
18	106-2951	2	Wheel
19	107-2236	1	Spring-Return, Brake
20	106-6508	4	Bushing
21	33098-00	4	Washer-Flat
22	3272-21	4	Pin-Cotter
23	106-2907	2	Tire
24	106-2953	1	Axle-Wheel, LH

Ref	Part No.	Qty.	Description
25	33018-00	2	Nut-Hex
26	106-2926	1	Washer-Bell
27	106-2925	1	Washer-Flat
28	106-2864	1	Axle-Front
29	106-2853	2	Washer-Flat
30	49-7810	1	Nut-Lock
31	106-2923	1	Lever-Foot Pedal
32	106-1807	1	Spacer
33	106-2964	1	Pedal
34	106-2961	1	Lever
35	106-2909	1	Ring-Retaining, Ext
36	106-2908	1	Ring-Retaining, Ext
37	106-2872	1	Shaft-Steering
38	106-1846	1	Pin-Roll
39	106-2883	1	Wheel-Steering
40	98-1459	1	Decal
41	106-2952	1	Axle-Wheel, RH
42	106-1835	3	Spacer
43	106-6544	4	Washer
44	106-6543	1	Pin-Grooved
45	106-2865	2	Washer-Flat
46	106-2879	1	Pin-Hair
47	106-6546	2	Zerk-Grease 90 DEG

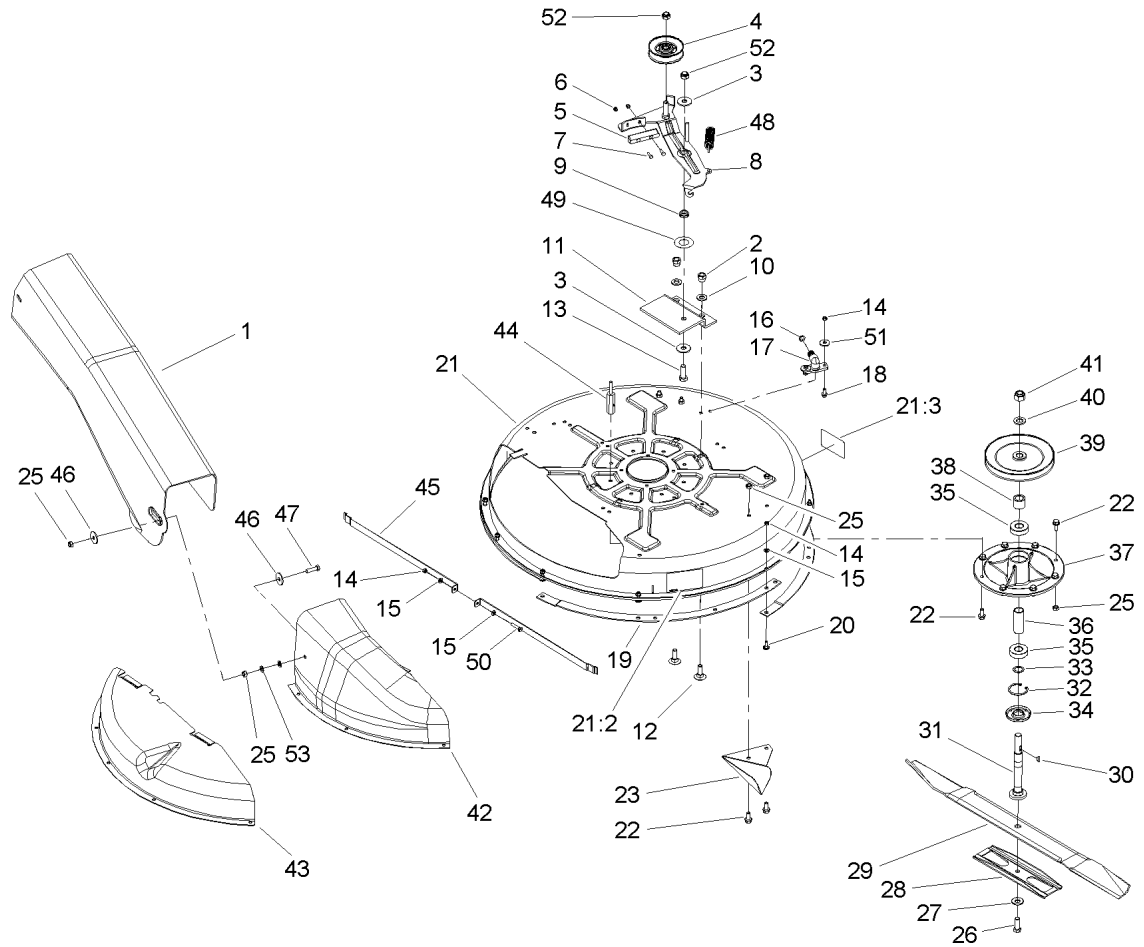

Deck and Spindle Assembly

Ref	Part No.	Qty.	Description
1	106-2970	1	Tube-Discharge
2	46-0090	2	Nut-Lock
3	106-2922	2	Washer-Flat
4	106-1813	1	Pulley-Idler
5	106-1814	1	Brake-Rubber
6	46-0410	2	Nut-Lock
7	60-6910	2	Screw
8	106-2889	1	Brake ASM
9	106-2892	1	Bushing
10	33096-00	2	Washer-Flat
11	106-2884	1	Bracket-Deck
12	33126-035	2	Screw-CARR
13	33116-035	1	Screw-HH
14	49-7810	11	Nut-Lock
15	33093-00	10	Washer-Flat
16	106-1847	1	O-Ring
17	95-2747	1	Fitting-Washout
18	33103-016	2	Screw-HHF
19	80-4490	4	Ring-Deck
20	106-6510	8	Screw-Sh
21	106-6545	1	Deck ASM
21:2		1	Decal-Caution
21:3		1	Decal-Discharge Cover
22	33104-020	13	Screw-HHF

Ref	Part No.	Qty.	Description
23	80-2630	2	Kicker
25	46-0330	14	Nut-Lock
26	3212-5	1	Screw-HH
27	106-2858	1	Washer-Bell
28	80-4570	1	Stiffener
29	106-6547	1	Blade-Recycler
30	106-1805	1	Key
31	106-2902	1	Shaft-Spindle
32	106-2910	1	Ring-Snap
33	106-1807	1	Spacer
34	80-4370	1	Shield-Bearing
35	251-297	2	Bearing
36	106-2888	1	Spacer
37	56-7030	1	Spindle
38	106-1842	1	Spacer
39	106-1812	1	Pulley
40	33098-00	1	Washer-Flat
41	106-2914	1	Nut-Hex
42	106-2898	1	Tunnel-Discharge
43	106-2899	1	Cover-Recycler
44	106-2897	1	Guide-Belt
45	106-6542	2	Strap-Deck
46	106-2855	2	Washer-Flat
47	33114-030	1	Screw-HH

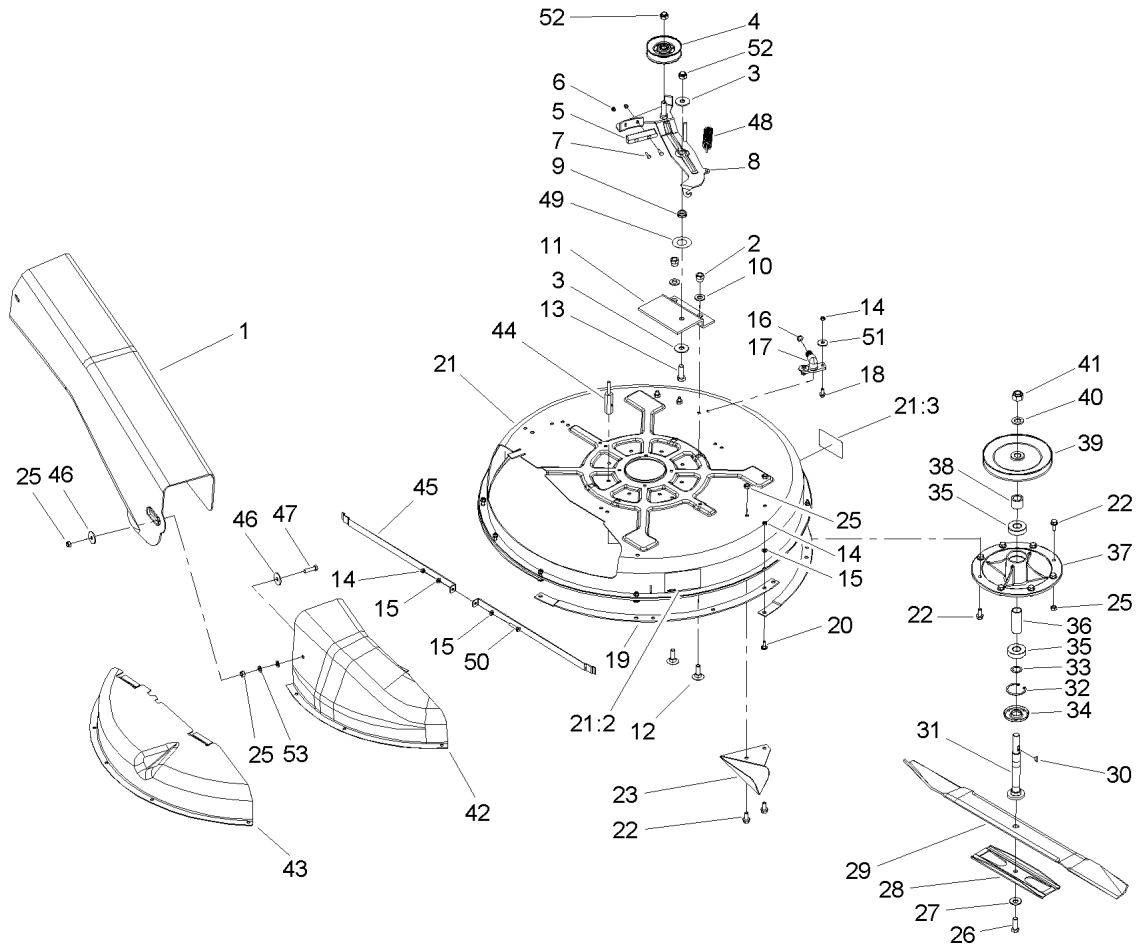

Deck and Spindle Assembly (continued)

Ref	Part No.	Qty.	Description
48	106-1838	1	Spring-Extension
49	106-2893	1	Spacer
50	33113-030	1	Screw-HH
51	106-2865	2	Washer-Flat
52	106-6513	2	Nut-Lock
53	33094-00	2	Washer-Flat

--	--	--	--

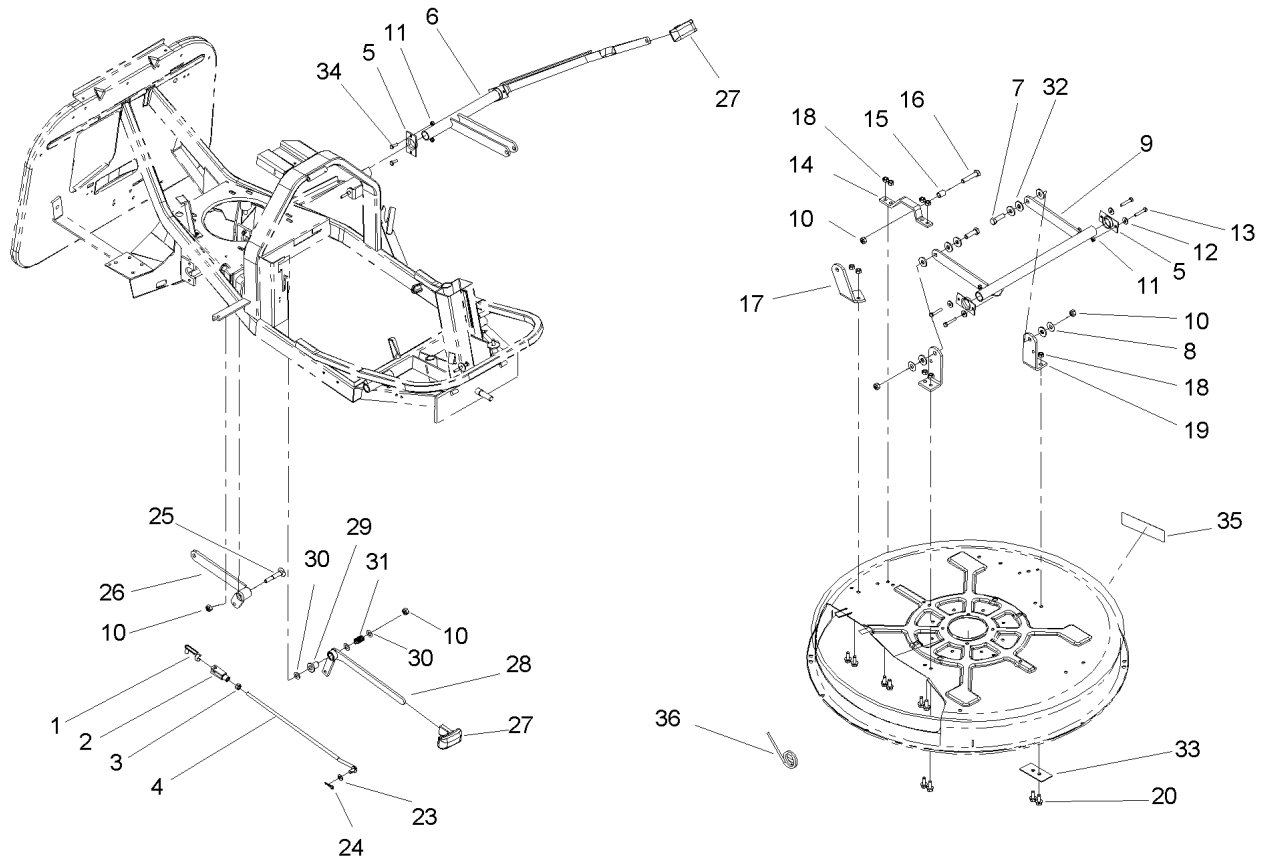

Deck Suspension Assembly

Ref	Part No.	Qty.	Description
1	106-1809	1	Retainer-Yoke
2	106-1803	1	Yoke
3	33014-00	1	Nut-Hex
4	106-2937	1	Rod-Tie
5	106-2880	3	Bracket-Support
6	107-8942	1	Lever-Lift
7	33115-035	3	Screw-HH
8	106-6511	6	Washer-Flat
9	106-1829	1	Hanger Deck ASM
10	33025-00	6	Nut-Lock
11	49-7810	8	Nut-Lock
12	106-2865	4	Washer-Flat
13	33113-035	4	Screw-HH
14	106-2895	1	Bracket-Deck
15	106-2912	1	Bushing
16	33115-050	1	Screw-HH
17	106-2894	1	Bracket-Deck
18	46-0330	10	Nut-Lock
19	106-2896	2	Bracket-Deck
20	33104-020	10	Screw-HHF
23	33094-00	1	Washer-Flat
24	106-2879	1	Pin-Hair
25	106-2882	1	Screw-CARR
26	106-1830	1	Hanger Deck ASM

Ref	Part No.	Qty.	Description
27	106-2967	2	Handle
28	106-2954	1	Lever-Blade, Clutch
29	106-2955	1	Bushing
30	106-2869	3	Shim
31	106-2950	1	Spring-Compression
32	106-1806	9	Washer
33	106-6512	1	Plate
34	33113-016	4	Screw-HH
35	106-6406	1	Decal-Recycler
36	107-2229	1	Spring-Lift, Deck

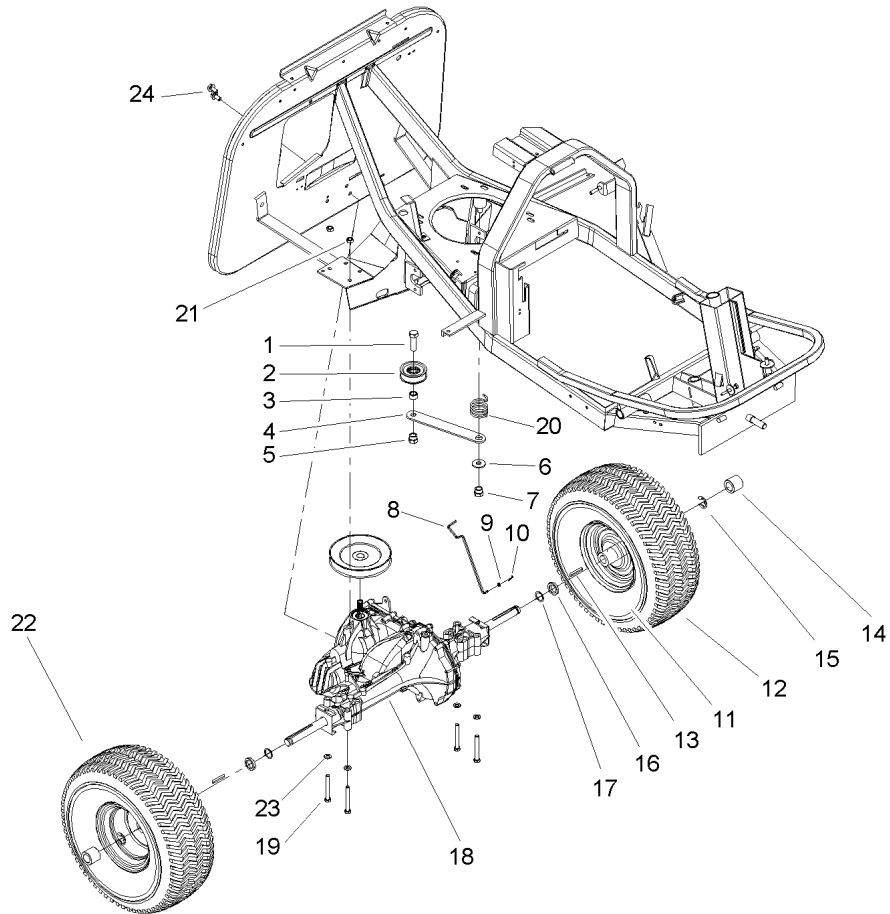

Rear Wheel and Transmission Assembly

Ref	Part No.	Qty.	Description
1	33116-040	1	Screw-HH
2	106-2877	1	Pulley ASM
3	106-2984	1	Spacer-Idler
4	106-2934	1	Bracket
5	46-0090	1	Nut-Lock
6	106-2921	1	Washer-Flat
7	33025-00	1	Nut-Lock
8	106-2968	1	Rod
9	106-2904	1	Washer-Flat
10	106-2996	1	Pin-Hair
11	106-2948	1	Wheel-LH
12	106-2913	2	Tire
13	106-2994	2	Key-Square
14	106-2949	2	Spacer
15	106-2909	2	Ring-Retaining, Ext
16	106-2993	2	Spacer
17	106-2992	2	Washer-Flat
18	106-1840	1	Transaxle-Hydro
19	106-2891	4	Screw-HH
20	106-2995	1	Spring-Extension
21	46-0330	4	Nut-Lock
22	106-2947	1	Wheel-RH
23	33094-00	4	Washer-Flat
24	106-6516	2	Screw-HHF TAP

--	--	--	--

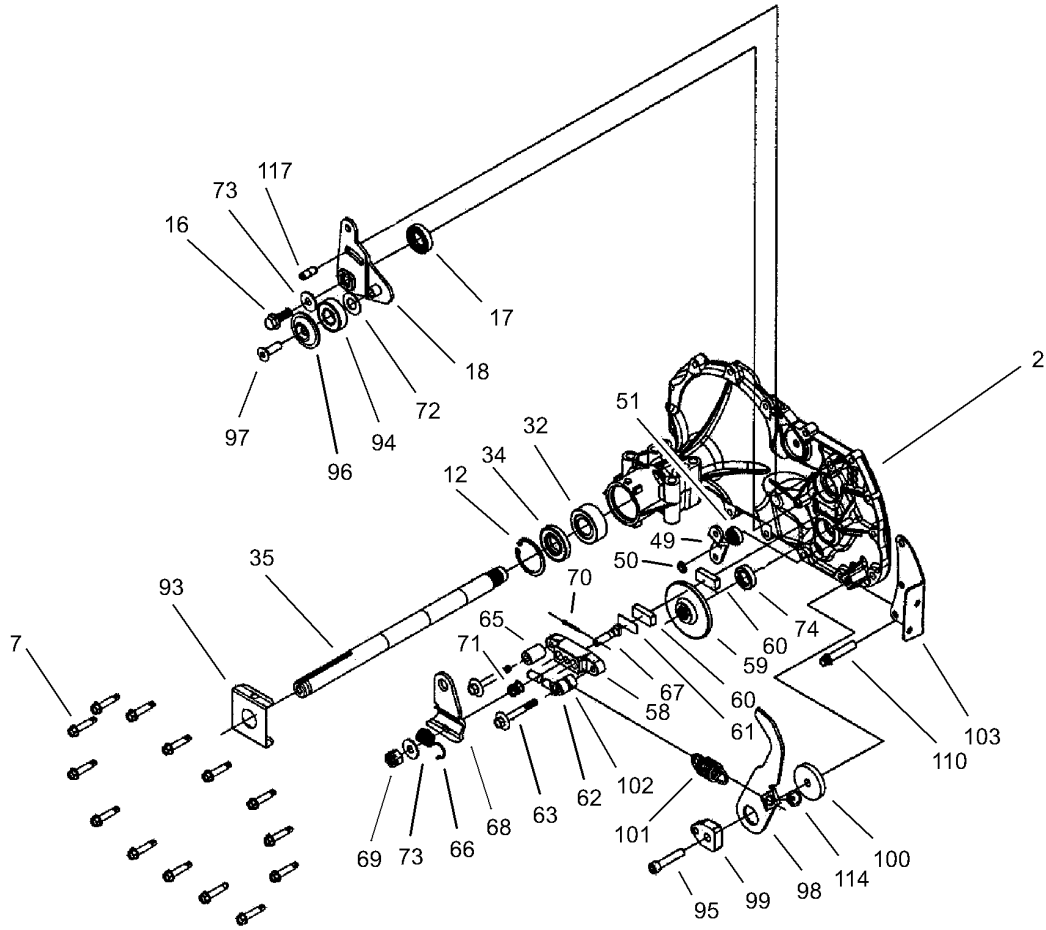

Hydro Transaxle-Assembly No. 106-1840

Ref	Part No.	Qty.	Description
2	104-5302	1	Side Housing ASM
7	104-5305	14	Screw-HHF
12	104-5309	1	Ring-Retaining
16	104-5312	1	Screw-HF
17	104-5313	1	Seal-Lip
18	104-5314	1	Arm-Control
32	104-5321	1	Bearing-Sleeve, Outboard
34	104-5322	1	Seal-Lip
35	104-5323	1	Shaft-Axle, RH
49	104-5336	1	Arm-Bypass
50	104-5337	1	Ring-Retaining
51	104-5338	1	Seal-Lip
58	106-6519	1	Brake Yoke
59	104-5344	1	Rotor-Brake
60	104-2171	2	Puck-Brake
61	104-2181	1	Puck-Plate
62	104-2176	2	Pin-Brake
63	104-5345	2	Screw-HF
65	104-2180	1	Spacer
66	104-2184	1	Spring-Arm, Brake
67	104-2174	1	Bolt-SQH
68	106-6520	1	Arm-Brake
69	93-3807	1	Nut-Castle
70	104-2179	1	Pin-Cotter

Ref	Part No.	Qty.	Description
71	104-2188	1	Spring-Brake, Anti Drag
72	94-1933	1	Washer
73	104-2146	2	Washer
74	104-5347	1	Seal-Oil
93	104-5353	1	Clip-Spring
94	104-2156	1	Bearing
95	104-2155	1	Screw
96	104-2157	1	Spacer-Locating
97	104-2158	1	Screw-Countersunk
98	104-5354	1	Arm-Return
99	104-2119	1	Puck-Adjusting
100	104-5355	1	Washer
101	104-5356	1	Spring-Extension
102	104-5357	1	Spacer
103	106-6521	1	Bracket,yoke
110	104-2148	1	Screw-TTH
114	104-5363	1	Guide-Spring
117	104-5365	1	Pin-Spring

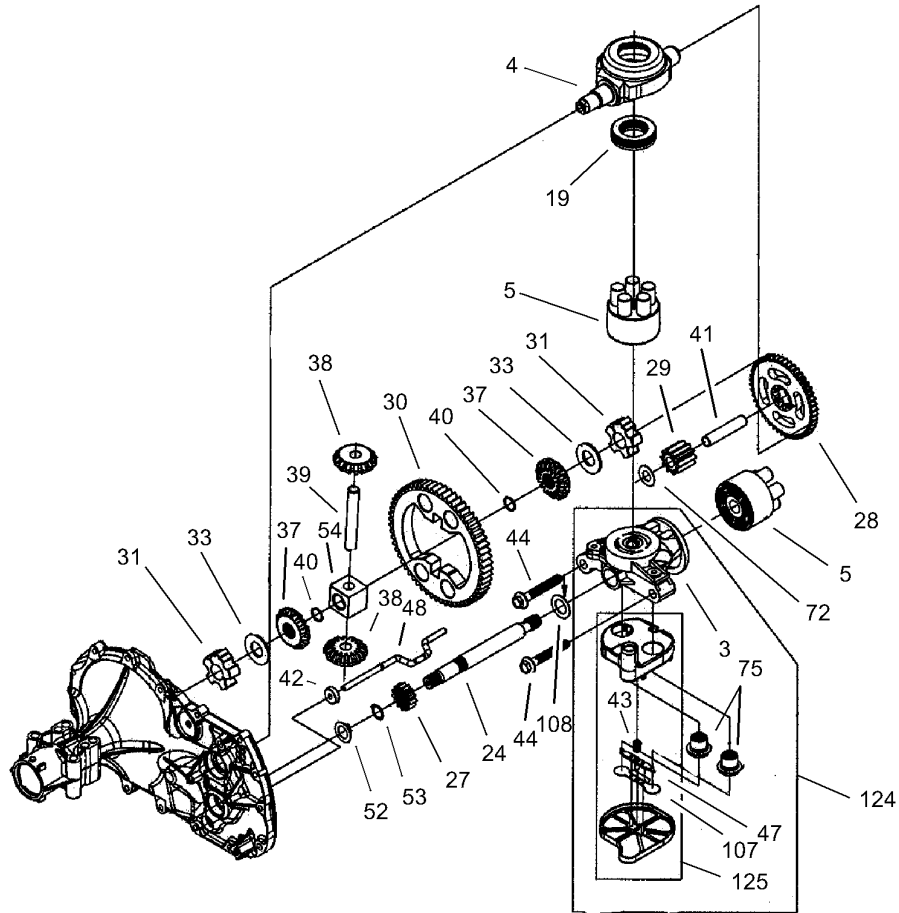

Hydro Transaxle-Assembly No 106-1840 (continued)

Ref	Part No.	Qty.	Description
3	104-5303	1	Center Section ASM
4	104-5304	1	Swashplate-Trunnion
5	104-2106	2	Cylinder Block ASM
19	94-6922	2	Bearing-Thrust
24	104-5315	1	Shaft-Motor
27	104-5316	1	Gear-Pinion, 13t
28	104-5317	1	Gear-10t/48t
29	104-5318	1	Gear-Jackshaft, 10t
30	104-5319	1	Gear-Bull, 60t
31	104-5320	2	Bearing-Sleeve
33	94-1943	2	Washer
37	104-5325	2	Gear-Miter
38	104-5326	2	Gear-Miter, 15t
39	104-5327	1	Shaft
40	104-5328	2	Ring-Retaining, Spiral
41	104-5329	1	Pin-Jackshaft
42	104-5330	1	Magnet-Ring
43	104-5331	1	Spring-Bypass
44	94-6926	2	Bolt
47	104-5334	1	Actuator-Bypass
48	104-5335	1	Rod-Actuator, Bypass
52	104-5339	1	Washer-Flat
53	104-5340	1	Ring-Retaining
54	104-5341	1	Bearing-Block, Center

Ref	Part No.	Qty.	Description
72	94-1933	2	Washer
75	104-5348	2	Check Plug ASM
107	104-5359	1	Deflector
108	104-5360	1	Washer-Shaft, Motor
124	106-6522	1	Center Section Filter Bypass ASM
125	106-6523	1	Filter ASM
● 127	104-5368	1	Seal Kit

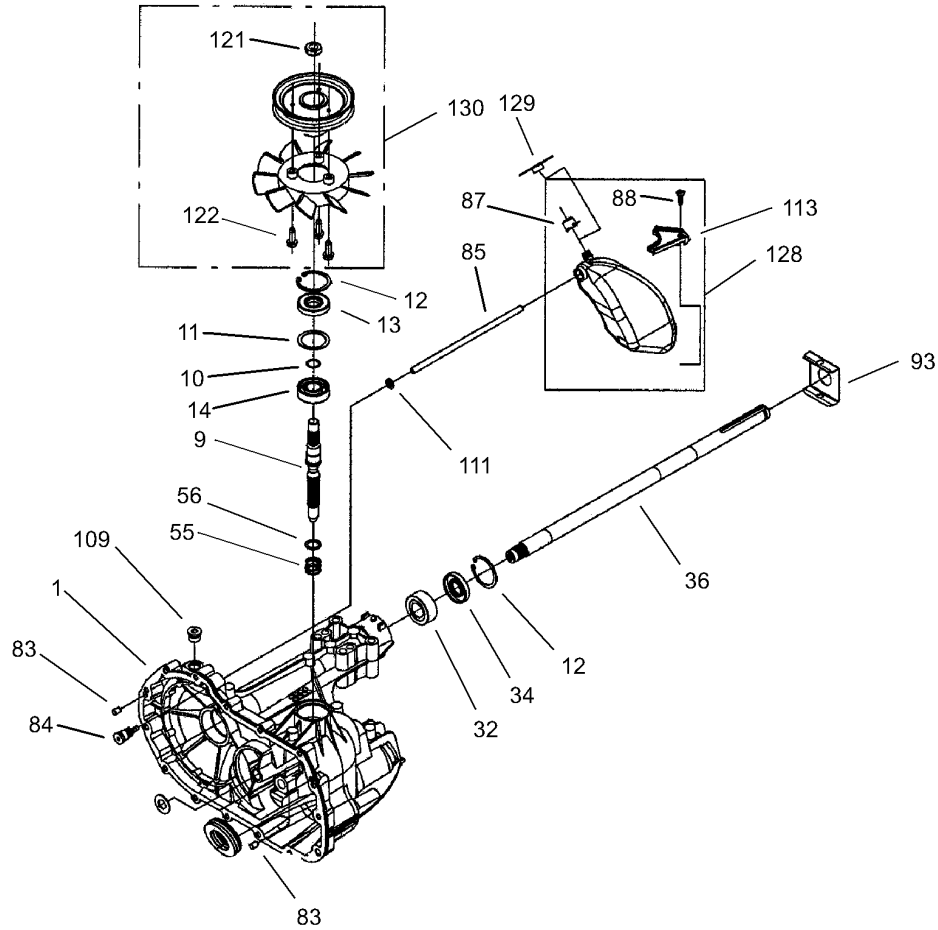

Hydro Transaxle-Assembly No. 106-1840 (continued)

Ref	Part No.	Qty.	Description
1	104-5301	1	Main Housing ASM
9	104-5306	1	Shaft-Input
10	104-5307	1	Ring-Retaining
11	104-5308	1	Spacer
12	104-5309	2	Ring-Retaining
13	104-5310	1	Seal-Lip
14	104-5311	1	Bearing-Ball
32	104-5321	1	Bearing-Sleeve, Outboard
34	104-5322	1	Seal-Lip
36	104-5324	1	Shaft-Axle, LH
55	94-1936	1	Spring-Block
56	94-1937	1	Washer-Block, Thrust
83	104-2170	2	Pin
84	104-5349	1	Fitting-Sae
85	104-5350	1	Hose-Expansion, Tank
87	104-5351	1	Cap-Vent
88	104-5352	1	Bolt-Tapping, Self
93	104-5353	1	Clip-Spring
109	104-2189	1	Plug-Thread, Straight
111	104-5361	1	O-Ring
113	104-5362	1	Bracket-Support
121	105-1875	1	Nut-Lock
122	104-2120	3	Screw
128	104-5369	1	Expansion Tank Kit

Ref	Part No.	Qty.	Description
129	104-5370	1	Cap
130	106-6524	1	Pulley Assembly

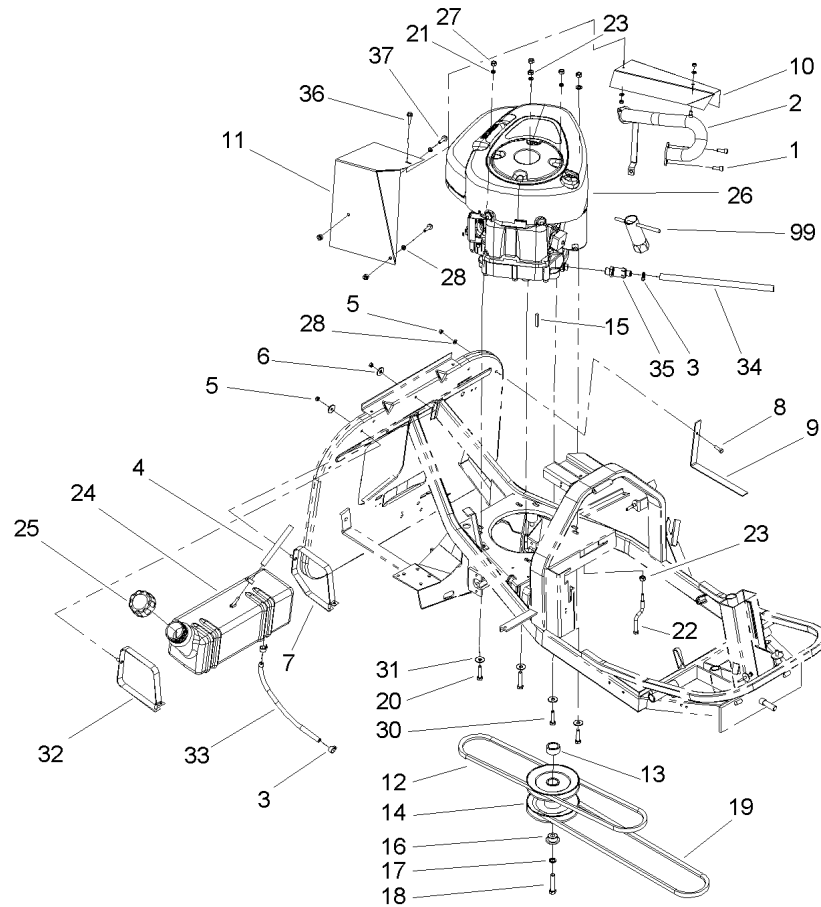

Engine and Fuel Tank Assembly

Ref	Part No.	Qty.	Description
1	3274-10	2	Screw-HSH
2	107-2233	1	Pipe-Exhaust
3	107-2210	4	Clamp-Tube
4	106-2990	1	Hose-Fuel
5	49-7810	8	Nut-Lock
6	106-2853	2	Washer-Flat
7	106-6541	1	Strap-Fuel Tank, Left
8	33113-020	1	Screw-HH
9	106-1828	1	Guard-Muffler
10	107-2235	1	Shield-Pipe, Exhaust
11	107-2234	1	Shield-Muffler, Rear
12	106-1825	1	Belt-Transmission
13	106-1836	1	Spacer
14	106-1833	1	Pulley-Engine
15	67-7490	1	Key-Square
16	106-1837	1	Spacer
17	106-2856	1	Washer-Lock
18	3212-8	1	Screw-HH
19	106-1826	1	Belt-Deck
20	33114-035	3	Screw-HH
21	33094-00	4	Washer-Flat
22	106-2974	2	Guide-Belt
23	33014-00	2	Nut-Hex
24	106-6537	1	Tank-Fuel

Ref	Part No.	Qty.	Description
25	55-3576	1	Gas Cap ASM
26		1	Engine-Briggs And Stratton, 31g777-0121-E1
27	46-0330	4	Nut-Lock
28	33093-00	6	Washer-Flat
30	33114-045	1	Screw-HH
31	106-2854	4	Washer-Flat
32	106-6540	1	Strap-Fuel Tank, Rt
33	107-1555	1	Hose-Fuel
34	107-2241	1	Tube-Drain, Oil
35	92-6877	1	Valve-Drain, Oil
36	33103-025	1	Screw-HHF
37	33103-030	2	Screw-HHF
99	107-8937	1	Plug-Wrench

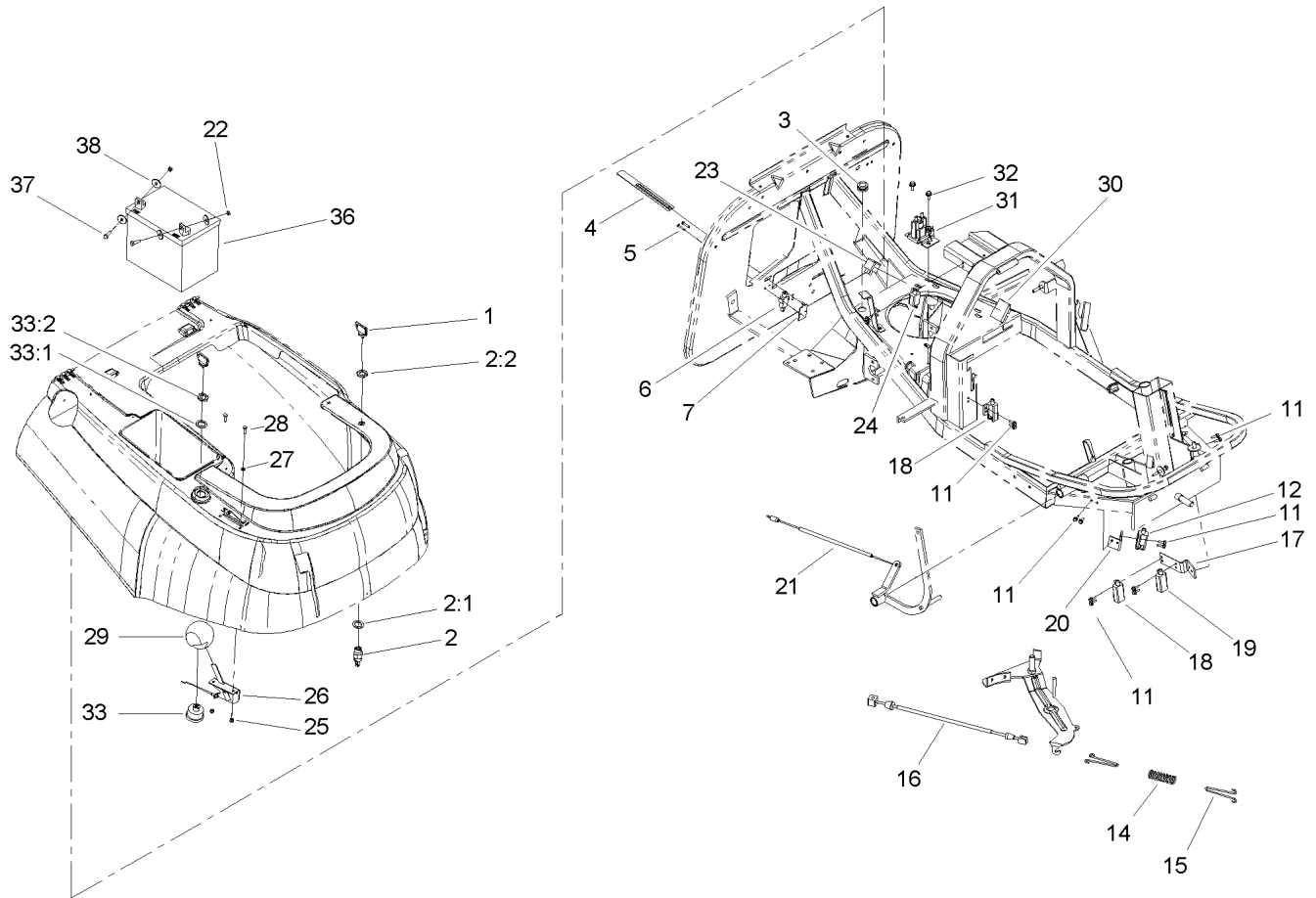

Electrical and Cable Assembly

Ref	Part No.	Qty.	Description
1	63-8360	2	Key-Ignition
2	46-5780	1	Switch-Starter
2:1	3254-5	1	Washer-Tooth
2:2	218-461	1	Nut-HH
3	106-2863	1	Grommet
4	106-1831	1	Lever-Bag Fill
5	106-2850	2	Screw
6	106-1843	1	Switch
7	106-1827	1	Clamp-Bag Fill
11	106-1849	14	Screw-HH TAP
12	100-8725	1	Switch-Double, Pole
14	106-2917	1	Spring-Compression
15	106-2918	2	Hook-Spring
16	106-2956	1	Cable
17	106-1808	1	Bracket-Switch
18	86-4690	2	Switch-Interlock
19	65-7410	1	Switch-Pole, Single
20	106-1816	1	Bracket-Switch
21	107-2237	1	Cable-Brake
22	33013-00	2	Nut-Hex
23	98-7249	1	Relay
24	65-7410	1	Switch-Pole, Single
25	46-0410	2	Nut-Lock
26	106-2916	1	Throttle Cable ASM

Ref	Part No.	Qty.	Description
27	52-6430	2	Washer
28	60-6910	2	Screw
29	106-2989	1	Knob
30	99-3700	1	Module
31	47-1910	1	Solenoid
32	106-2852	2	Screw-HHF TAP
33	88-9830	1	Key Switch ASM
33:1	3254-5	1	Washer-Tooth
33:2	218-461	1	Nut-HH
36	104-1755	1	Battery
37	33113-020	2	Screw-HH
38	106-2853	4	Washer-Flat
99	106-1841	1	Harness-Wire

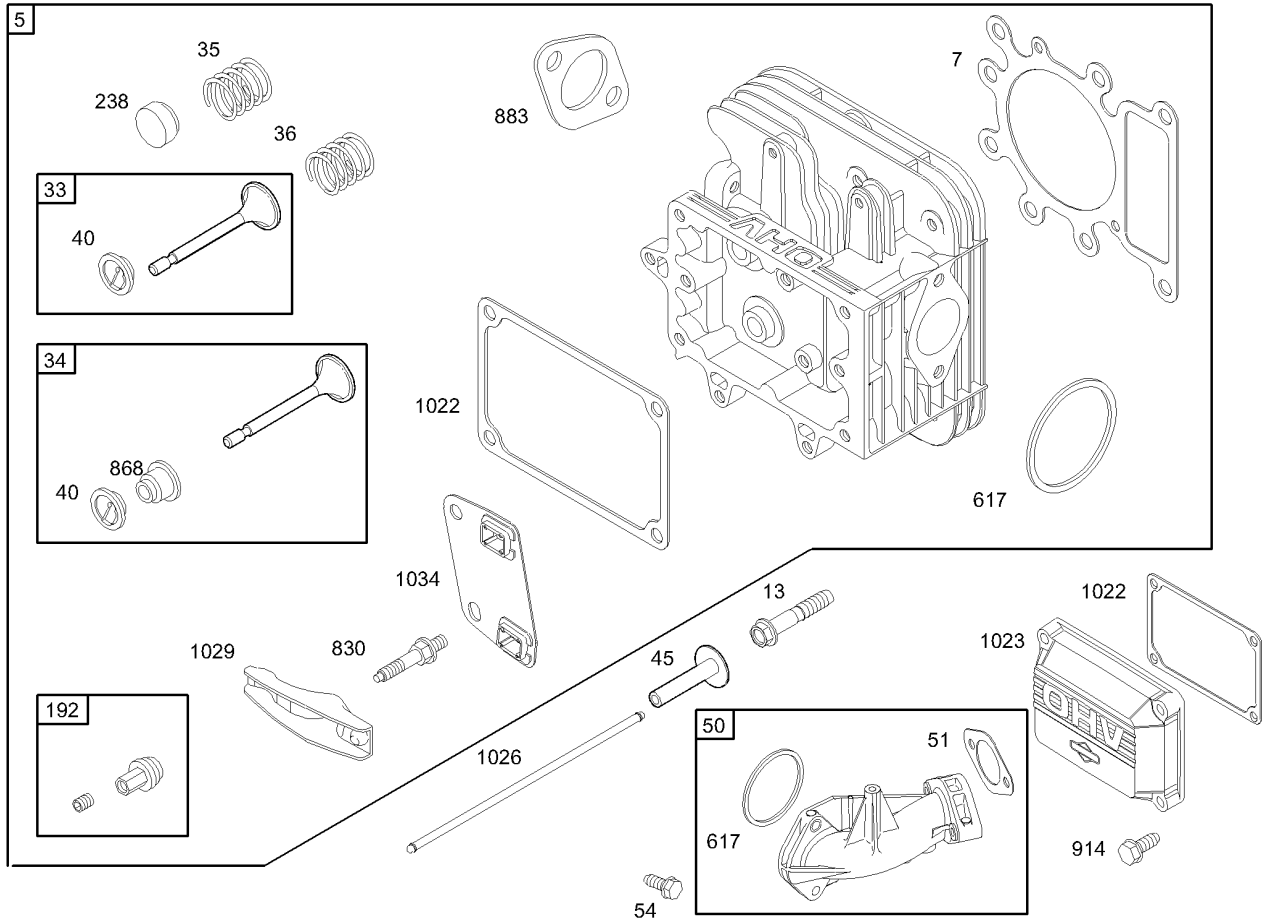

Cylinder Head Assembly Briggs and Stratton 31G777-0121-E1

Ref	Part No.	Qty.	Description
5	698147	1	Head-Cylinder
3 4 7	692410	1	Gasket-cylinder Head
7	690360	1	Screw-Cylinder Head Gasket
7 33	695760	1	Valve-exhaust
7 34	695761	1	Valve-intake
7 35	691279	1	Spring-valve, Intake
7 36	691279	1	Spring-valve, Intake
7 40	691752	1	Retainer-Valve
7 45	690564	1	Tappet-valve
7 50	690193	1	Manifold-intake
3 4 51	692137	1	Gasket-intake
5 6			
7 54	691148	1	Screw-Intake Manifold
7 192	691986	1	Adjustor-arm, Rocker
7 238	691843	1	Cap-valve
3 5 617	692138	1	Seal-o Ring (Intake Manifold)
7			
7 830	691095	1	Stud-rocker Arm
3 4 868	690968	1	Seal-valve
7			
7 883	692236	1	Gasket-exhaust
7 914	690960	1	Screw (Blower Housing)
3 7 1022	272475	1	Gasket-rocker Cover
7 1023	692492	1	Cover-rocker

Ref	Part No.	Qty.	Description
7 1026	692003	1	Rod-push, Intake
7	692011	1	Rod-push, Exhaust
7 1029	691751	1	Arm-rocker
7 1034	690822	1	Guide-push Rod

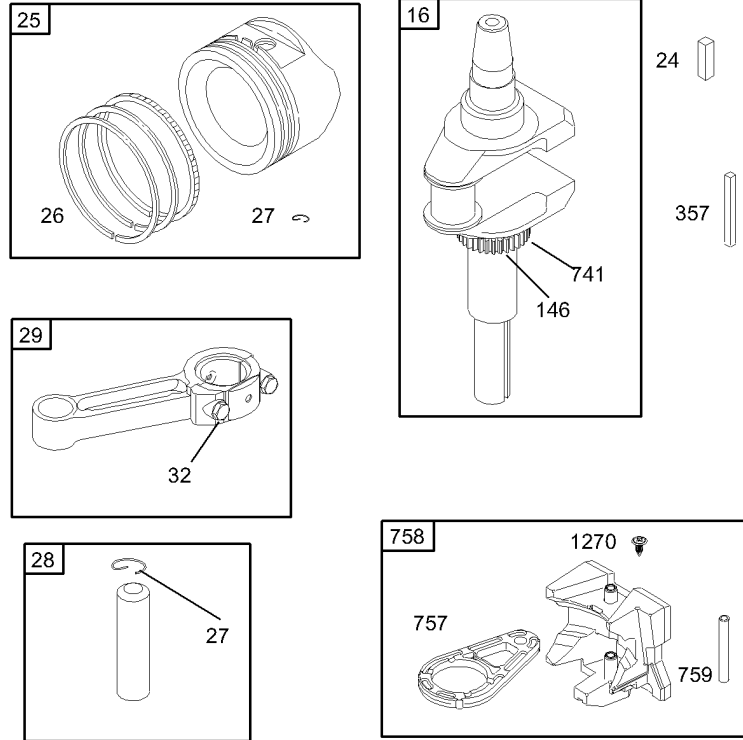

Assemblies include all parts shown in frames.

Crankshaft Assembly Briggs and Stratton 31G777-0121-E1

Ref	Part No.	Qty.	Description
16	697127	1	Crankshaft
24	222698	1	Flywheel Key
25	697159	1	Piston ASM (Standard)
	697160	1	Piston ASM (.010" Oversize)
	697162	1	Piston ASM (.020" Oversize)
	697163	1	Piston ASM (.030" Oversize)
26	697164	1	Ring Set (Standard)
	697165	1	Ring Set (.010" Oversize)
	697171	1	Ring Set (.020" Oversize)
	697172	1	Ring Set (.030" Oversize)
27	698469	1	Lock-piston Pin
28	697099	1	Pin-piston (Standard)
29	697126	1	Rod-connecting (Standard)
	697263	1	Rod-Connecting (.020in Undersize)
32	692852	1	Screw (Connecting Rod)
146	691639	1	Key-timing
357	691483	1	Key-drive Pulley
741	697128	1	Gear-timing
757	697607	1	Link-counterweight
758	697134	1	Counterweight
759	697392	1	Pin-counterweight
1270	697156	1	Plug-counterweight, Avs

--	--	--	--

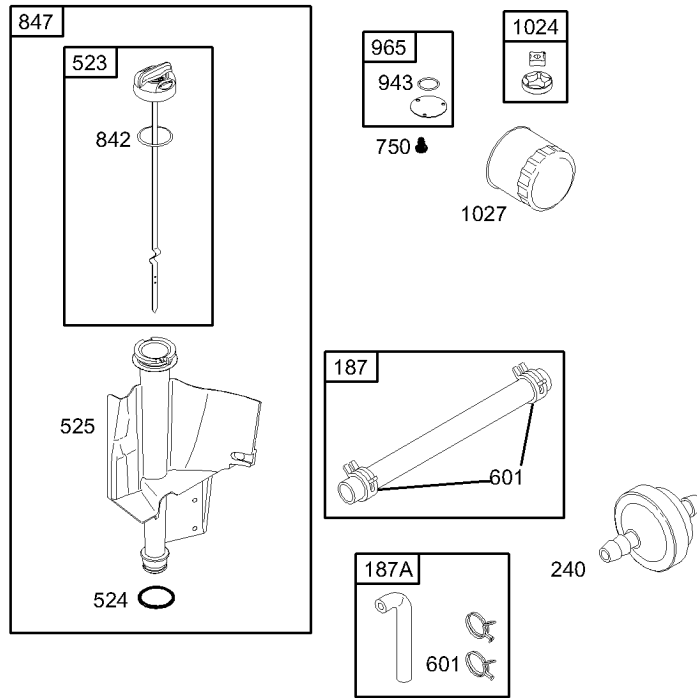

Assemblies include all parts shown in frames.

Oil Filter, Tube and Pump Assembly Briggs and Stratton 31G777-0121-E1

Ref	Part No.	Qty.	Description
187	296004	1	Fuel-Hose
187A	698820	1	Line-Fuel
240	298090	1	Filter
523	697086	1	Dipstick
524	691032	1	Seal-dipstick Tube
525	697085	1	Tube-dipstick
601	691038	1	Clamp-hose
750	691033	1	Screw-Oil Pump Cover
842	691031	1	O Ring Seal (Dipstick Tube)
847	697087	1	Dipstick/tube ASM
943	690589	1	Seal-o Ring (Oil Pump Cover)
965	499613	1	Cover-pump, Oil
1024	499054	1	Pump-oil
1027	492932	1	Filter-oil

--	--	--	--

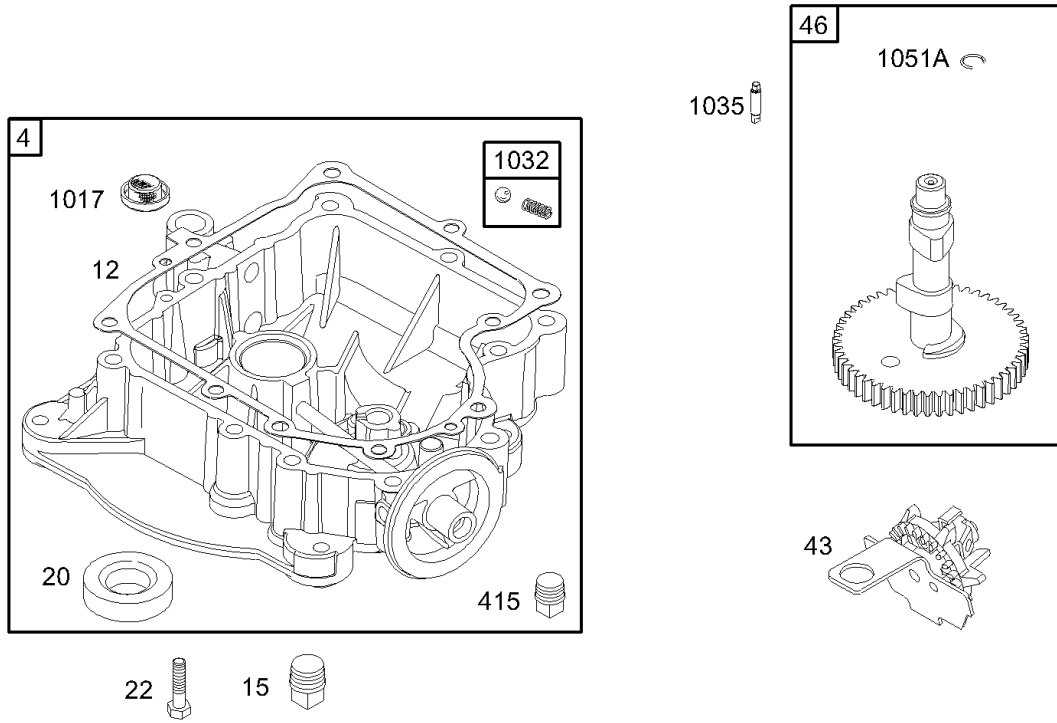

Assemblies include all parts shown in frames.

Crankcase Assembly Briggs and Stratton 31G777-0121-E1

Ref	Part No.	Qty.	Description
4	697188	1	Sump-engine
12	697110	1	Gasket-crankcase
15	690946	1	Plug-drain, Oil
20	690947	1	Seal-oil (Pto Side)
22	692125	1	Screw-Engine Sump
43	691968	1	Governor/oil Slinger
46	698492	1	Camshaft
415	690283	1	Plug-oil
1017	690770	1	Screen-Oil Pump
1032	491710	1	Ball-pump, Oil
1035	693784	1	Shaft-pump
1051A	698802	1	Ring-Retaining

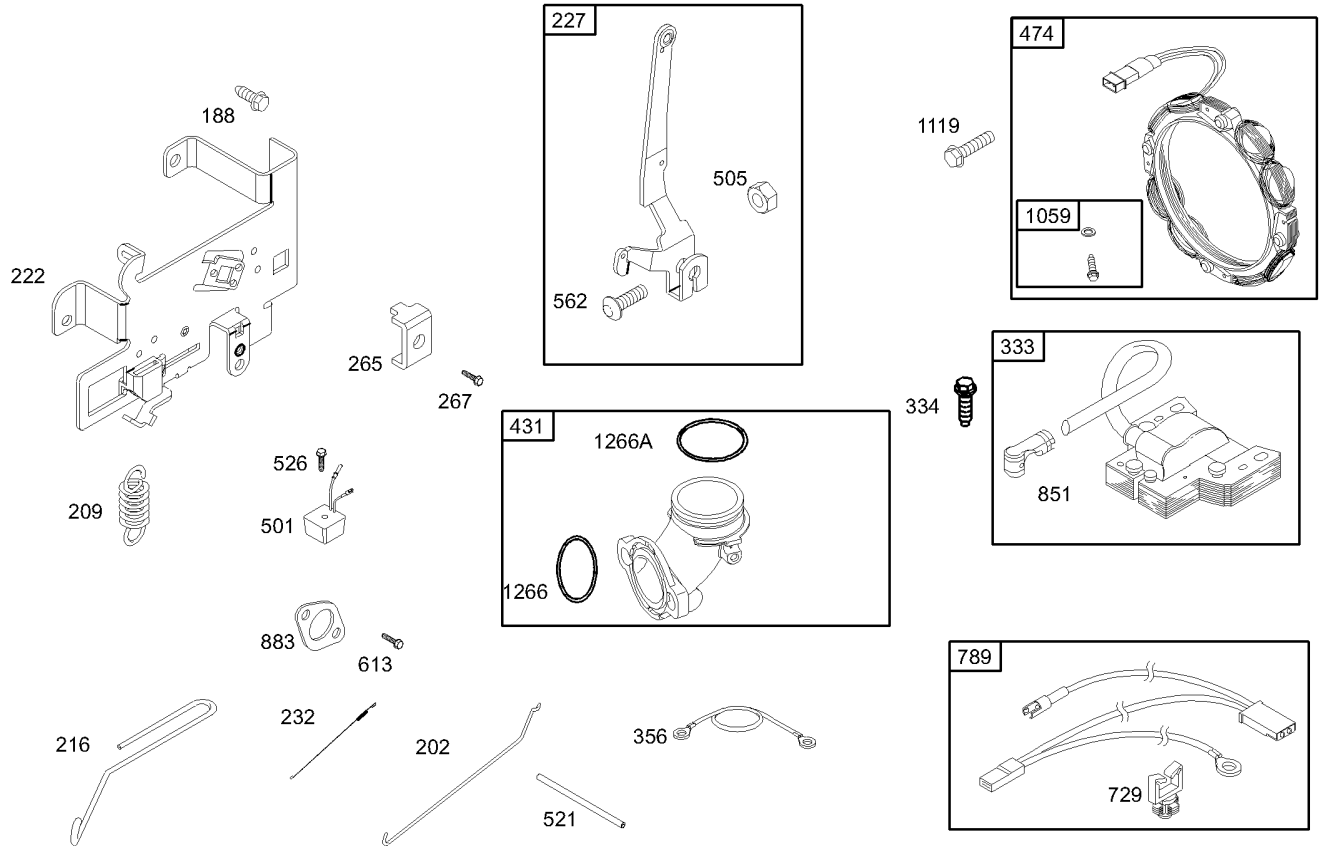

Assemblies include all parts shown in frames.

Governor Assembly Briggs and Stratton 31G777-0121-E1

Ref	Part No.	Qty.	Description
188	691693	1	Screw (Oil Fill Bracket)
202	691841	1	Link-governor, Mechanical
209	691795	1	Spring-governor
216	691840	1	Link-choke
222	694042	1	Bracket-control
227	691374	1	Lever-control, Governor
232	691842	1	Spring-governor Link
265	691024	1	Clamp-casing
267	690804	1	Screw-Casing Clamp
333	492341	1	Armature-magneto
334	691061	1	Screw (Magneto Armature)
356	697089	1	Stop-wire
431	697122	1	Elbow-intake
474	696457	1	Alternator
501	691188	1	Regulator
505	691251	1	Nut (Governor Control Lever)
521	690581	1	Shield-Cable
526	697088	1	Screw-Regulator
562	691119	1	Bolt-Governor Control Lever
613	698941	1	Screw-Exhaust
729	691335	1	Clip-wire
789	692037	1	Wiring-harness
851	692424	1	Terminal-spark Plug
883	692236	1	Gasket-exhaust

Ref	Part No.	Qty.	Description
1059	698516	1	Kit-screw/washer
1119	691183	1	Screw-Alternator
1266	691917	1	Seal-o Ring (Intake Elbow)
1266A	697123	1	Seal-o Ring, Intake Elbow

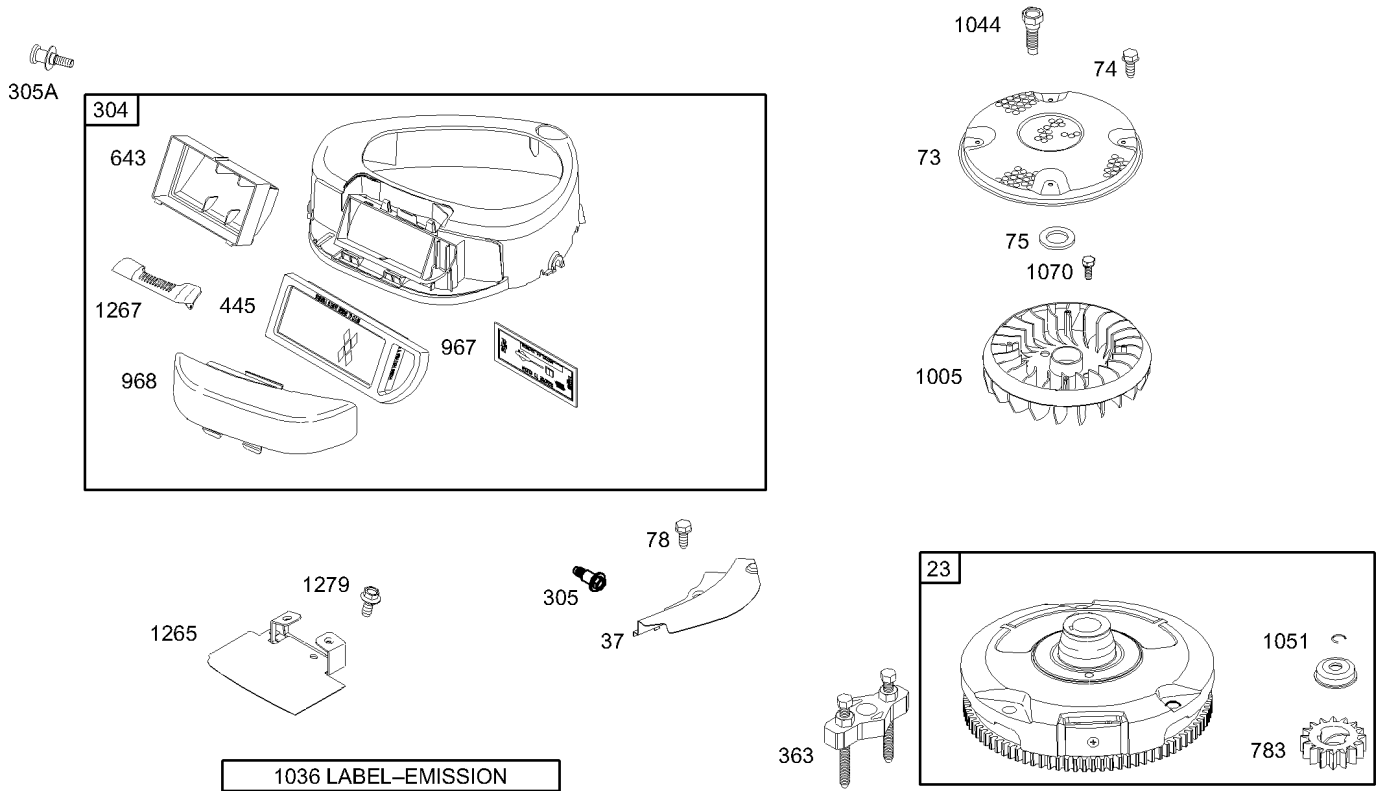

Assemblies include all parts shown in frames.

Blower Housing Assembly Briggs and Stratton 31G777-0121-E1

Ref	Part No.	Qty.	Description
⑦23	693556	1	Flywheel
⑦37	697108	1	Guard-flywheel
⑦73	697133	1	Screen-rotating
⑦74	697897	1	Screw-Rotating Screen
⑦75	690582	1	Washer-Flywheel
⑦78	691003	1	Screw-Flywheel Guard
⑦304	698804	1	Housing-Blower
⑦305	697102	1	Screw-Blower Housing
⑦305A	697103	1	Screw-Blower Housing
⑦363	19203	1	Puller-flywheel
⑦445	698083	1	Filter-air Cleaner Cartridge (Non Washable)
⑦643	698401	1	Retainer-air Filter
⑦783	693713	1	Gear-pinion
⑦967	697015	1	Filter-pre Cleaner
⑦968	697084	1	Cover-Air Cleaner
⑦1005	697111	1	Fan-flywheel
⑦1036	695700	1	Label-emission
⑦1044	691658	1	Screw-Crankshaft Extension
⑦1051	691265	1	Ring-retaining
⑦1070	690372	1	Screw-Drive Cap
⑦1265	697125	1	Support-blower Housing
⑦1267	697135	1	Latch-Blower Housing
⑦1279	690960	1	Screw (Blower Housing)

--	--	--	--

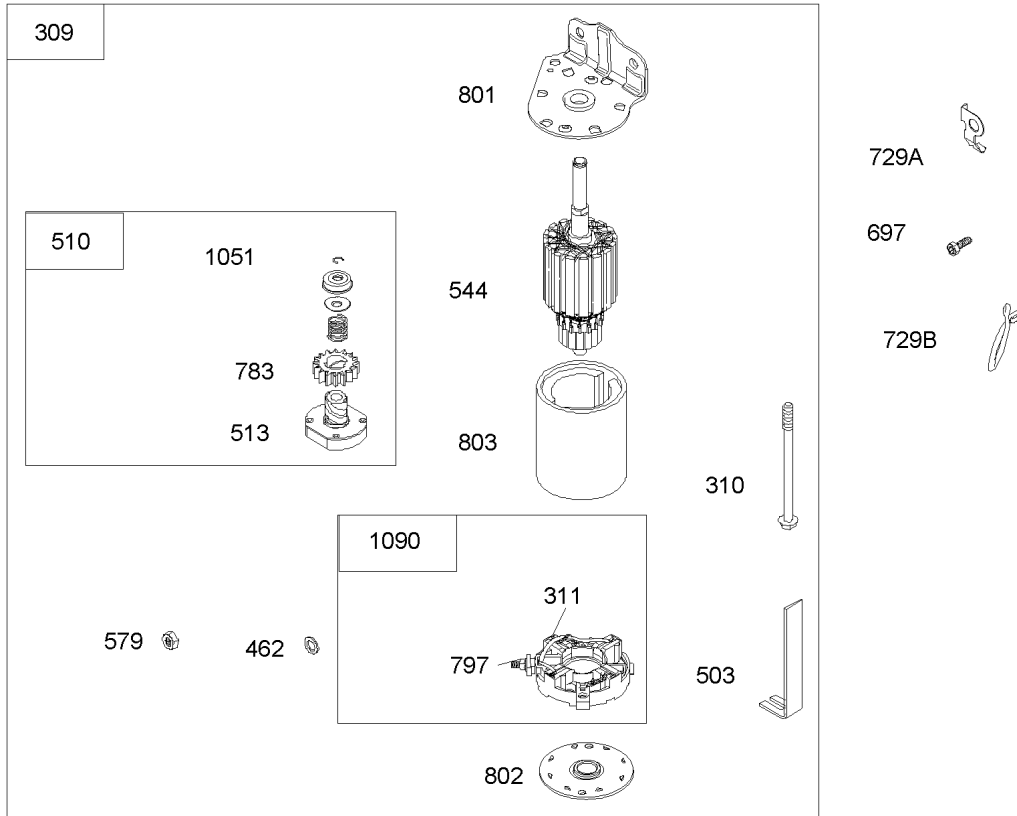

Assemblies include all parts shown in frames.

Starter Assembly Briggs and Stratton 31G777-0121-E1

Ref	Part No.	Qty.	Description
309	693551	1	Motor-starter
310	690323	1	Bolt-Starter Motor
311	497608	1	Brush Set
462	691261	1	Washer-Brush Retainer
503	691532	1	Strap-starter
510	693699	1	Drive-starter
513	692024	1	Drive Clutch
544	692034	1	Armature-starter
579	691029	1	Nut-Brush Retainer
697	690372	1	Screw-Drive Cap
729A	691224	1	Clip-wire
729B	694123	1	Clip-wire
783	693713	1	Gear-pinion
797	693167	1	Nut-Brush Retainer
801	691283	1	Cap-drive
802	691286	1	Cap-end
803	693757	1	Housing-starter
1051	691265	1	Ring-retaining
1090	691293	1	Retainer-brush

--	--	--	--

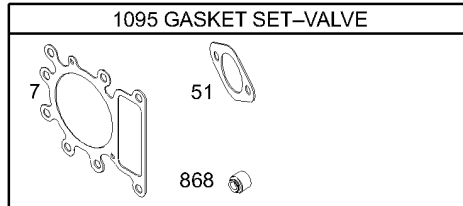
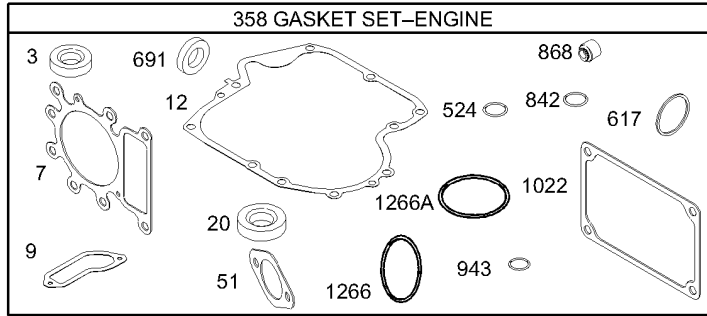

Assemblies include all parts shown in frames.

Gasket Assembly Briggs and Stratton 31G777-0121-E1

Ref	Part No.	Qty.	Description				
373	391086	1	Seal-oil (Magneto Side)				
477	692410	1	Gasket-cylinder Head				
79	697109	1	Gasket-breather				
712	697110	0	Gasket-crankcase				
720	690947	1	Seal-oil (Pto Side)				
4517	692137	1	Gasket-intake				
7358	697191	1	Gasket Set-engine				
7524	691032	1	Seal-dipstick Tube				
7617	692138	1	Seal-o Ring (Intake Manifold)				
7691	692407	1	Seal-governor Shaft				
7842	691031	1	O Ring Seal (Dipstick Tube)				
48687	690968	1	Seal-valve				
7943	690589	1	Seal-o Ring (Oil Pump Cover)				
71022	272475	1	Gasket-rocker Cover				
71095	691581	1	Gasket Set-valve				
71266	691917	1	Seal-o Ring (Intake Elbow)				
71266A	697123	1	Seal-o Ring, Intake Elbow				

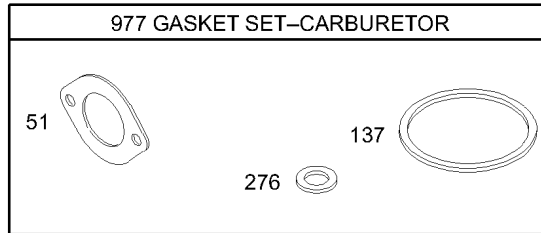
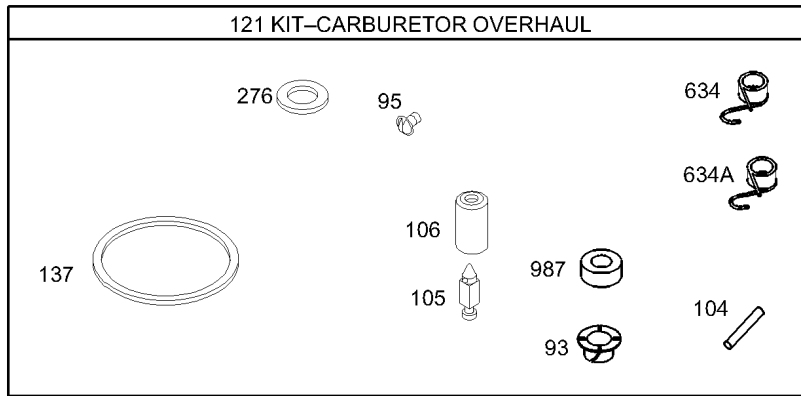

Assemblies include all parts shown in frames.

Carburetor Overhaul Kit Assembly Briggs and Stratton 31G777-0121-E1

Ref	Part No.	Qty.	Description
5751	692137	1	Gasket-intake
5793	690602	1	Bushing-shaft, Throttle
5795	691636	1	Screw (Throttle Valve)
57104	690525	1	Pin-hinge, Float
57105	231855	1	Valve-needle, Float
57106	691780	1	Seat-inlet
7121	697884	1	Kit-Carburetor Overhaul
56137	281165	1	Gasket-float Bowl
56276	692255	1	Washer-sealing
57634	690801	1	Spring/seal ASM
57634A	690802	1	Spring/seal Assembly
7977	690192	1	Gasket Set-carburetor
57987	691326	1	Seal-shaft, Throttle

NOTES

NOTES

