



Winter Enclosure

Groundsmaster® 3200 or 3300 Series Traction Unit

Model No. 31990—Serial No. 417400000 and Up

Operator's Manual

Safety

This product complies with all relevant European directives. For details, please see the Declaration of Incorporation (DOI) at the back of this publication.

Rollover Protection System (ROPS) for a Cab

- The ROPS is an integral part of the cab, which is an effective safety device.
- The ROPS consists of the roll bar, the seat, the seat belt, the seat latch, and cab.
- Always wear the seat belt when you operate the machine with a cab.
- Ensure that the seat belt can be released quickly in the event of an emergency.
- Drive slowly and carefully.
- Check carefully for overhead clearances (i.e., branches, doorways, electrical wires) before driving under any objects and do not contact them.
- Keep the cab in safe operating condition by periodically thoroughly inspecting for damage and keeping all mounting fasteners tight.
- Replace a damaged cab. Do not repair or revise.
- **Do not** remove or modify the ROPS.

Safety and Instructional Decals



Safety decals and instructions are easily visible to the operator and are located near any area of potential danger. Replace any decal that is damaged or missing.

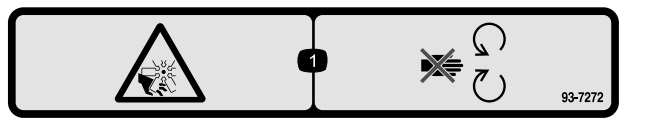

93-7272

decal93-7272

1. Cutting/dismemberment hazard; fan—stay away from moving parts.

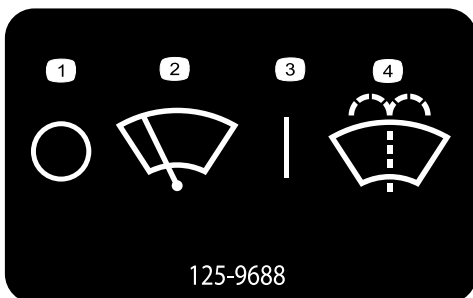

125-9688

decal125-9688

1. Windshield wipers—off
2. Windshield wipers
3. Windshield wipers—on
4. Spray windshield washer fluid





130-5361

decal130-5361

1. Warning—read the *Operator's Manual*; operate the machine only from the driver's seat; wear a seatbelt; wear hearing protection.

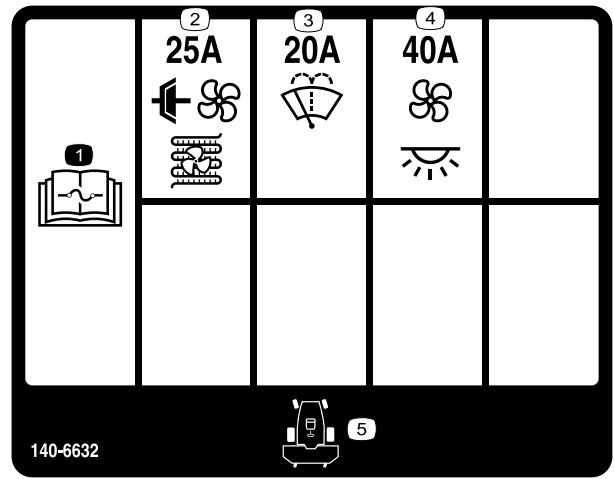

140-6632

decal140-6632

1. Read the *Operator's Manual* for fuse information.
2. A/C clutch and condenser fan (25 A)
3. Windshield washer (20 A)
4. Fan and interior light (40 A)
5. Front of machine

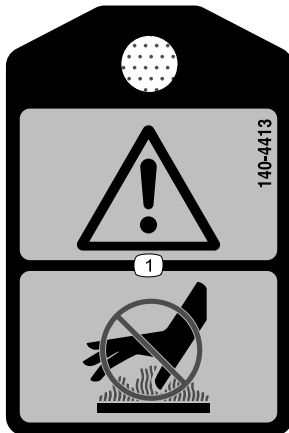

140-4413

decal140-4413

1. Warning—do not touch the hot surface.

Setup

Loose Parts

Use the chart below to verify that all parts have been shipped.

Procedure	Description	Qty.	Use
1	Bolt (3/4 x 4 inches)	2	Prepare the machine and cab.
	Nut (3/4 inch)	2	
2	Cab firewall	1	Install the cab firewall.
3	Cab	1	Install the cab.
	Left ROPS stop	1	
	Right ROPS stop	1	
	ROPS mount	2	
	ROPS brace	2	
	Retainer cover	2	
	Seal	2	
	Screw (1/4 x 3/4)	8	
	Bolt (3/8 x 1 inch)	4	
	Locknut (3/8 inch)	4	
Foam seal	1		
4	Bolt (5/16 x 1-1/2 inch)	2	Install the vent tubes.
	Nut (5/16 inch)	2	
	Plate clamp	2	
	Tube clamp	2	
5	Step mount	1	Install the step.
	Carriage bolt (3/8 x 7/8 inch)	2	
	Nut (3/8 inch)	2	
	Carriage bolt (5/16 x 3/4 inch)	2	
	Carriage bolt (5/16 x 1-1/4 inch)	1	
	Nut (5/16 inch)	3	
	Deck step	1	
Floor mat	1		
6	Hose	1	Install the hoses for the 24 hp engine.
	Female coupler	1	
	Female dust plug	1	
	Straight fitting (3/8 NPT x 5/8 barb)	2	
	Hose clamp	4	
	Male coupler	1	
	Male dust plug	1	
	R-clamp	2	
	Carriage bolt (1/4 x 3/4 inch)	2	
	Flange nut (1/4 inch)	2	
	Engine fitting	2	
	Cable ties	8	
	Straight adaptor (3/8 inch)	1	
	Adaptor (M16)	1	

Procedure	Description	Qty.	Use
7	Hose Female coupler Female dust plug Straight fitting (3/8 NPT x 5/8 barb) Hose clamp Male coupler Male dust plug R-clamp Carriage bolt (1/4 x 3/4 inch) Flange nut (1/4 inch) Engine fitting Cable ties Straight adaptor (3/8 inch) Adaptor (M16)	1 1 1 2 4 1 1 2 2 2 2 8 1 1	Install the hoses for the 37 hp engine.
8	Washer-fluid bracket Washer-fluid tank Carriage bolt (5/16 x 3/4 inch) Locknut (5/16 inch)	1 1 4 4	Install the washer-fluid tank.
9	Female-hose fitting Male-hose fitting	1 1	Install the washer fluid hoses.
10	Fuse (10 A)	1	Connect the wire harness.
11	Weight (6 kg or 15 lb) Bolt (3/8 x 3-1/2 inches) Washer (3/8 inch) Locknut (3/8 inch)	2 2 2 2	Install the weights.
12	No parts required	–	Complete the installation.

1

Preparing the Machine and Cab

Parts needed for this procedure:

2	Bolt (3/4 x 4 inches)
2	Nut (3/4 inch)

Procedure

Note: Save the shipping pallet for long term storage after the cab is removed. Save all hardware for the machine when installing or removing the cab.

1. Park the machine on a level surface, engage the parking brake, lower the attachment, shut off the engine, and remove the key.
2. Disconnect the negative (-) battery cable from the battery.
3. Remove the nut, bolt, and spacer securing the cable to the traction pedal and rotate the pedal towards the seat (Figure 1).

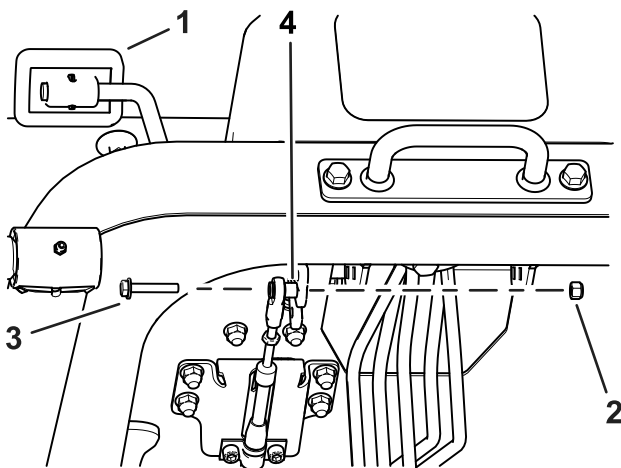

Figure 1

g301596

- | | |
|---------------|-----------|
| 1. Foot pedal | 3. Bolt |
| 2. Locknut | 4. Spacer |

4. Remove the ROPS pins and place them into down position hole (Figure 2).

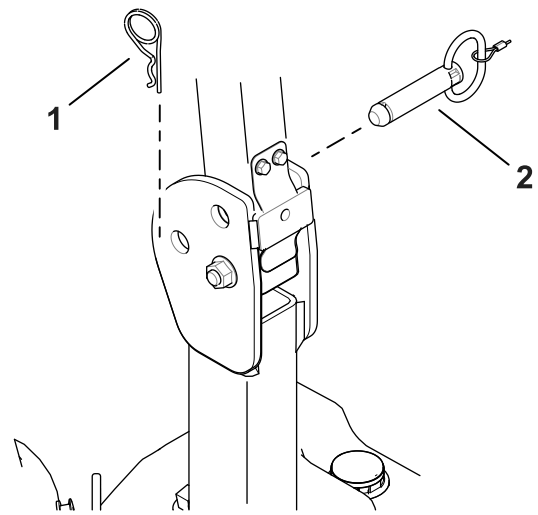

Figure 2

g302033

- | | |
|---------------|--------|
| 1. Cotter pin | 2. Pin |
|---------------|--------|

5. Install the bolt (3/4 x 4 inches) into the top hole of the roll bar and secure it finger tight with a nut (3/4 inch). Refer to (Figure 3).

Note: Ensure that the bolt is installed on the inside of the roll bar.

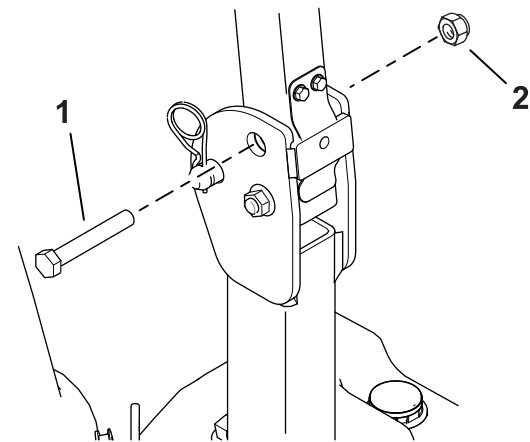

Figure 3

g302032

- | | |
|-----------------------------------------------------|-------------------|
| 1. Install the bolt (3/4 x 4 inches) on the inside. | 2. Nut (3/4 inch) |
|-----------------------------------------------------|-------------------|

6. Remove the front mower-deck latch from the front of the machine (Figure 4). Save the latch and hardware.

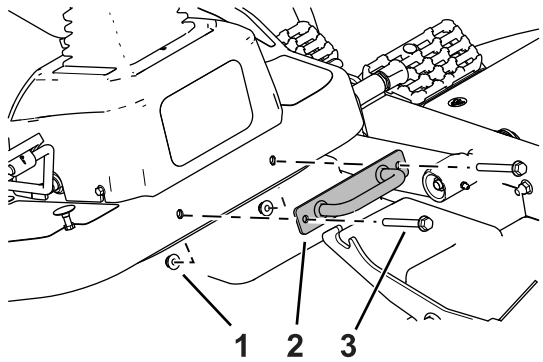

Figure 4

g302034

- 1. Nut
- 2. Mower-deck latch
- 3. Bolt

7. Remove the nuts and bolts from the right armrest and fold it to the center (Figure 5).

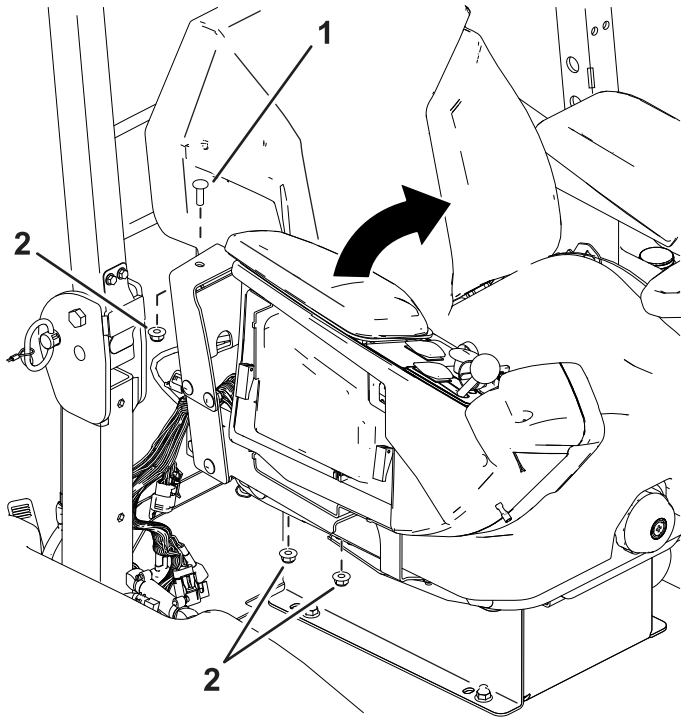

Figure 5

g301595

- 1. Bolt
- 2. Locknut

8. Tilt the steering column to its lowest position; refer to the *Operators Manual*.

9. Remove the R-clamps from the roll bar securing the vent tubes (Figure 6).

10. Lay the vent tubes out of the way for mounting the cab.

11. Install the R-clamps back into the roll bar without the vent tubes (Figure 6).

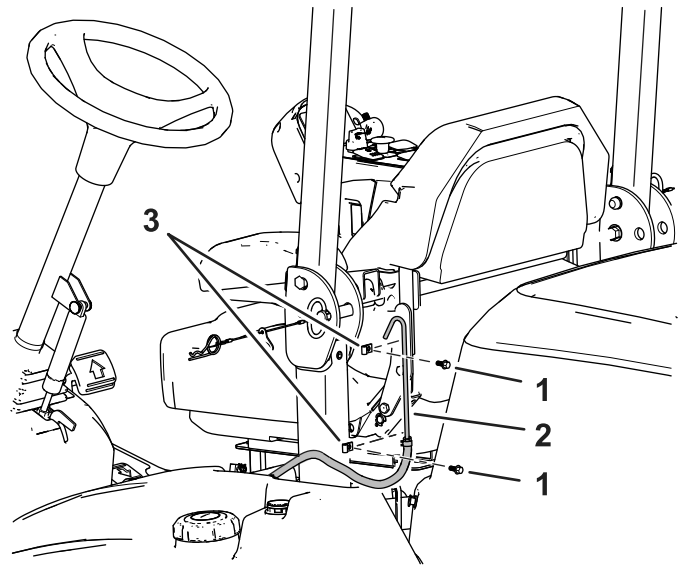

Figure 6

g301597

- 1. Bolt
- 2. Fuel-vent tube
- 3. R-clamp

2

Installing the Cab Firewall

Parts needed for this procedure:

1	Cab firewall
---	--------------

Procedure

1. Caulk the existing firewall openings on both sides at the locations shown in [Figure 7](#) with black RTV sealant.

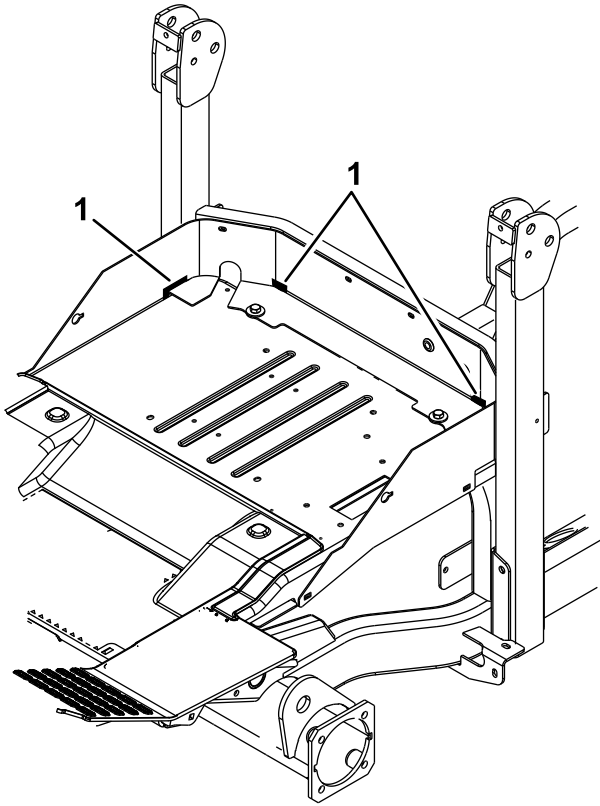

Figure 7

g301598

1. Caulk these areas on both sides.

2. Caulk the cab firewall at the locations shown in [Figure 8](#) with black RTV sealant.

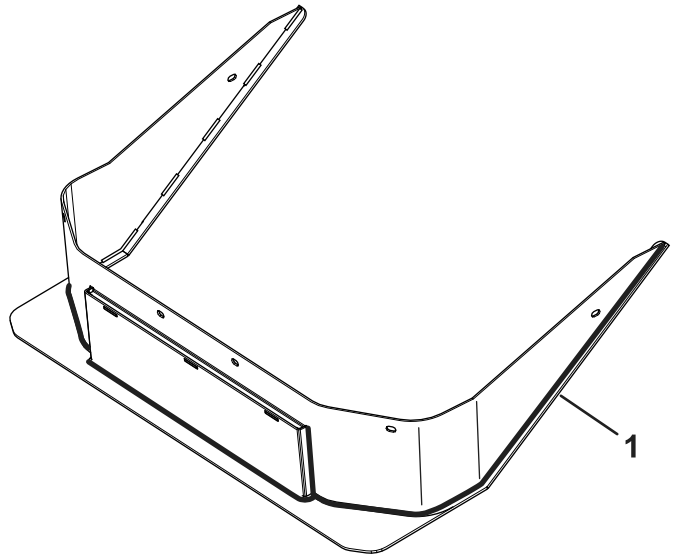
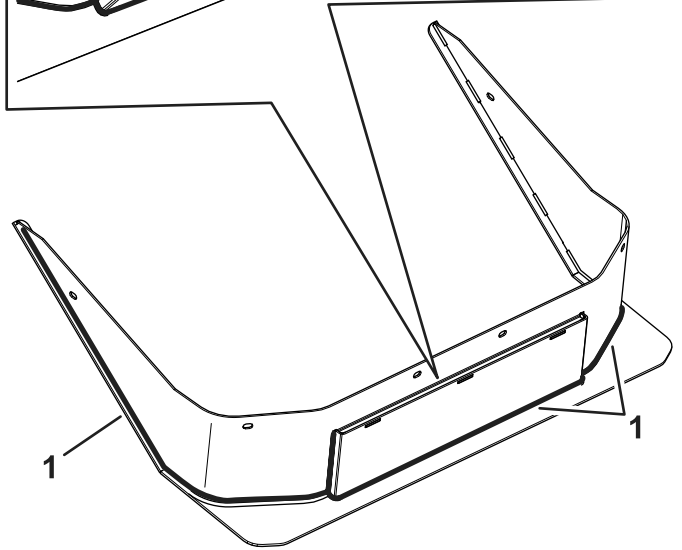
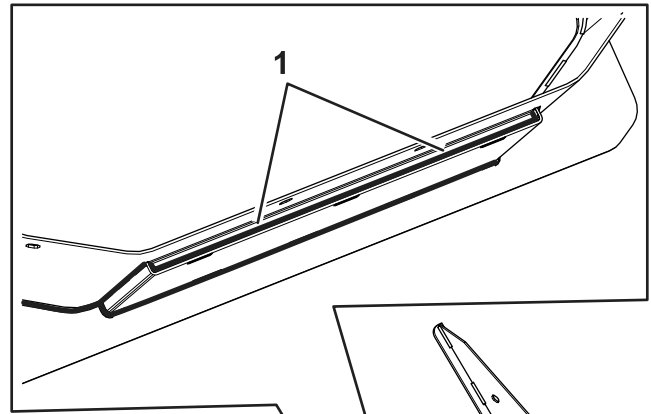

Figure 8

g336508

1. Caulk these areas only

3. Remove the existing hardware that connects the existing firewall to the roll bar tube.
4. Place the cab firewall around the seat and onto the existing firewall ([Figure 9](#)).

3

Installing the Cab

Parts needed for this procedure:

1	Cab
1	Left ROPS stop
1	Right ROPS stop
2	ROPS mount
2	ROPS brace
2	Retainer cover
2	Seal
8	Screw (1/4 x 3/4)
4	Bolt (3/8 x 1 inch)
4	Locknut (3/8 inch)
1	Foam seal

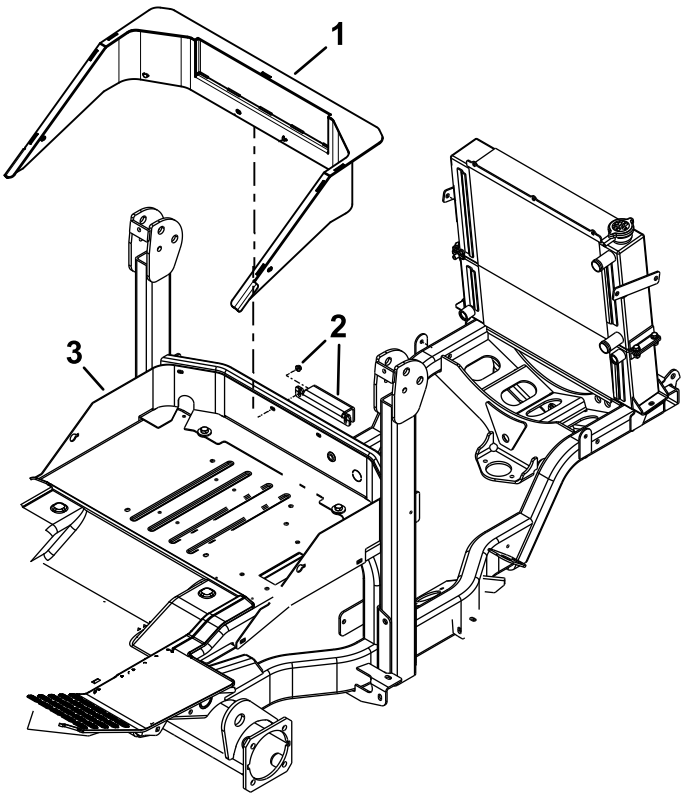

g301513

Figure 9

- 1. Cab firewall
 - 2. Existing hardware—reuse
 - 3. Existing firewall
-
- 5. Use the existing hardware to install the cab firewall.

Procedure

Important: Loosely install the fasteners for the cab until all hardware is installed. After all the hardware is installed, tighten the fasteners.

- 1. Remove the left and right panels from inside the cab as shown in [Figure 10](#).

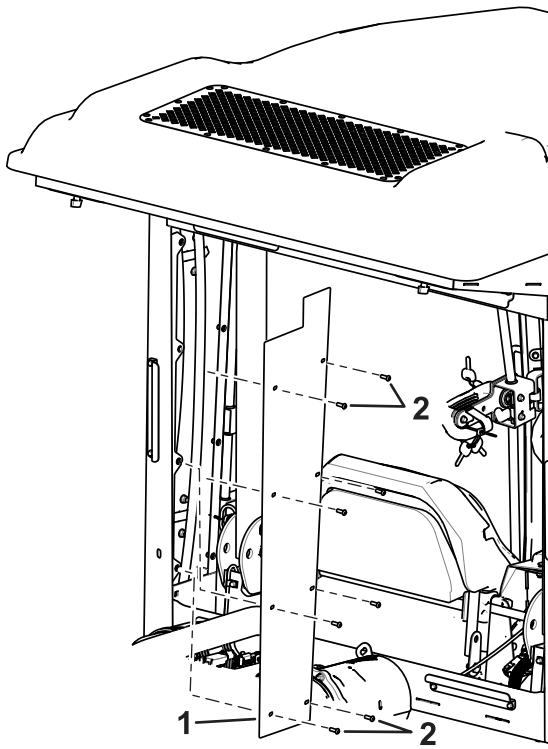

Figure 10

g301842

1. Left panel
2. Screws

2. Remove the cab roof as shown in [Figure 11](#).

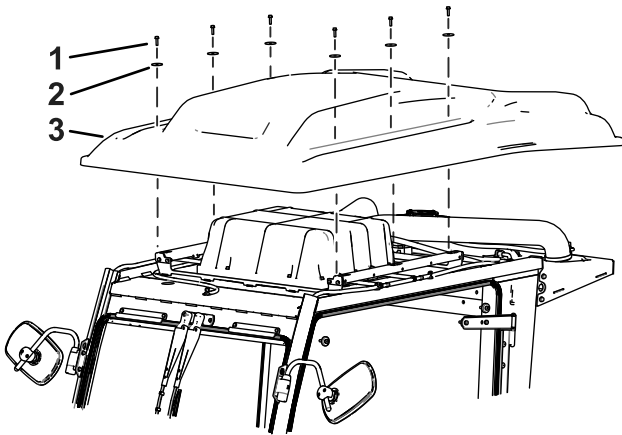

Figure 11

g302035

1. Bolt
2. Washer
3. Cab roof

3. Use a hoist to support the cab and connect the cab hoist to the 4 lift points on the cab ([Figure 12](#)).

Note: A cab hoist is available through your authorized Toro distributor.

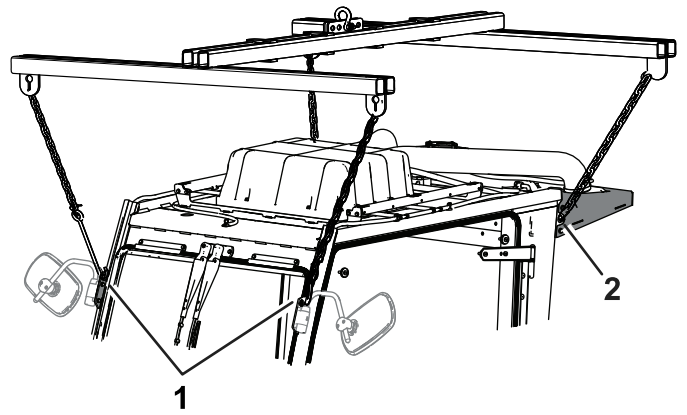

Figure 12

g322358

1. Front lift point
2. Rear lift point

4. Raise the cab with a hoist ([Figure 12](#)).
5. Install the foam seal on the bottom of the cab as shown in [Figure 13](#).

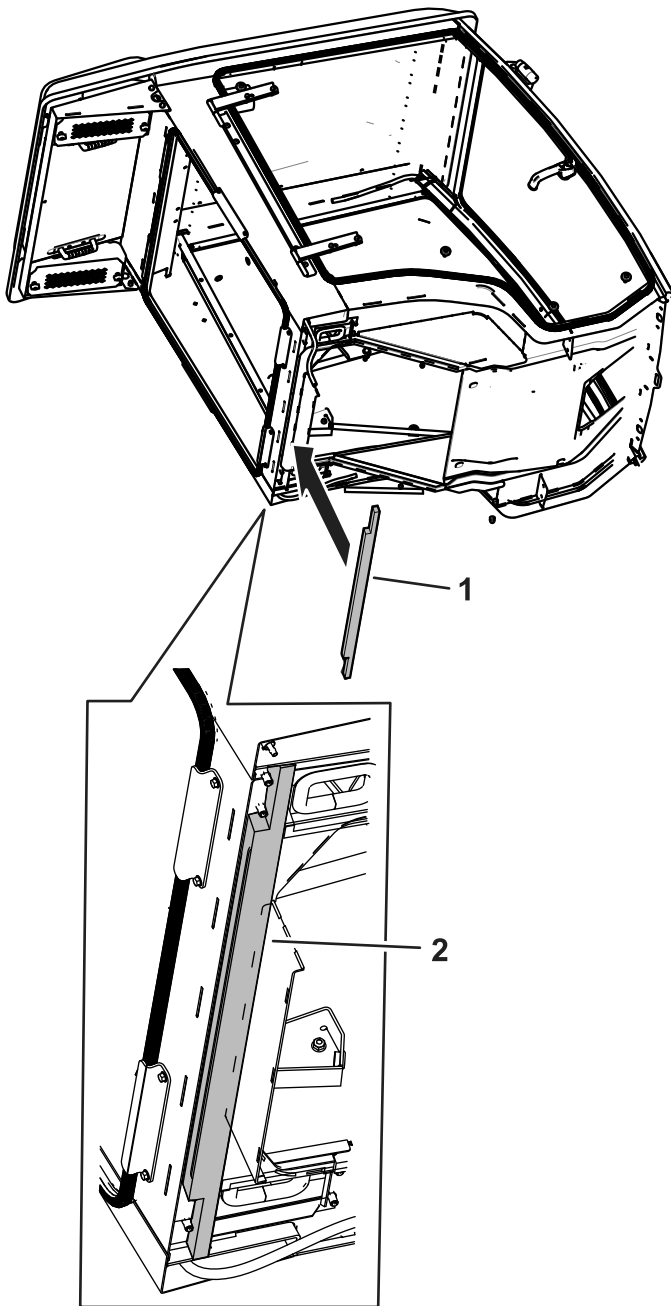

Figure 13

g301543

- 1. Foam seal
- 2. Foam seal installed

- 6. Align the cab over the roll bar.
 - 7. While lowering the cab, position the vent tubes through the rear posts (Figure 16).
- Note:** Ensure that the traction pedal is rotated rearward towards the seat.
- 8. Lower the cab until it is approximately 51 mm (2 inches) above the firewall and machine.
 - 9. Install the roll bar seals around each side of the roll bar (Figure 14).

- 10. Install the left cover and 1 retainer cover into the left seal and secure the covers with 4 screws (1/4 x 3/4 inches); refer to Figure 14.
- 11. Install the right cover and 1 retainer cover into the right seal and secure the covers with 4 screws (1/4 x 3/4 inches); refer to Figure 14.

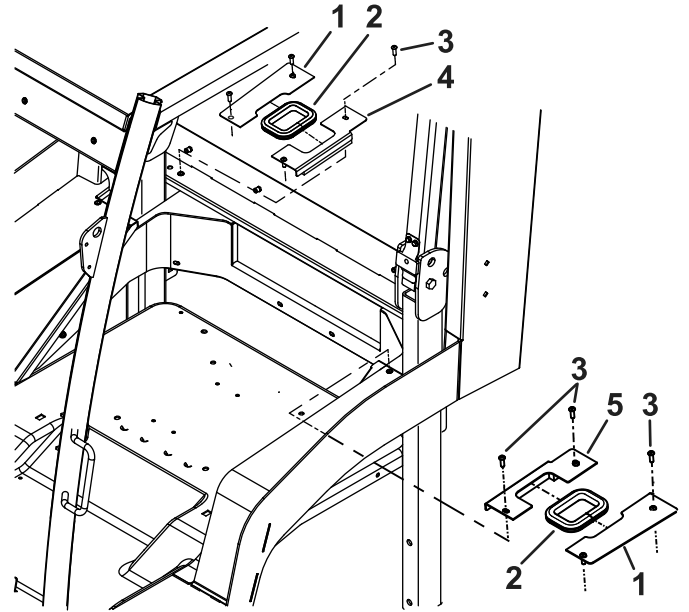

Figure 14

g301688

- 1. Retainer cover
- 2. Roll bar seal
- 3. Screws (1/4 x 3/4 inches)
- 4. Right cover
- 5. Left cover
- 6. Covers installed

- 12. Lower the cab onto the firewall and machine.
- 13. Loosely install the mower deck latch to the front of the cab (Figure 4).
- 14. Loosely install the ROPS mounts to secure the cab to the roll bar on the machine (Figure 15).
- 15. Loosely install the left ROPS stop on the corner of the roll bar with 2 bolts (3/8 x 1 inch), a ROPS brace, and 2 nuts (3/8 inch).
- 16. Loosely install the right ROPS stop on the corner of the roll bar with 2 bolts (3/8 x 1 inch), a ROPS brace, and 2 nuts (3/8 inch).

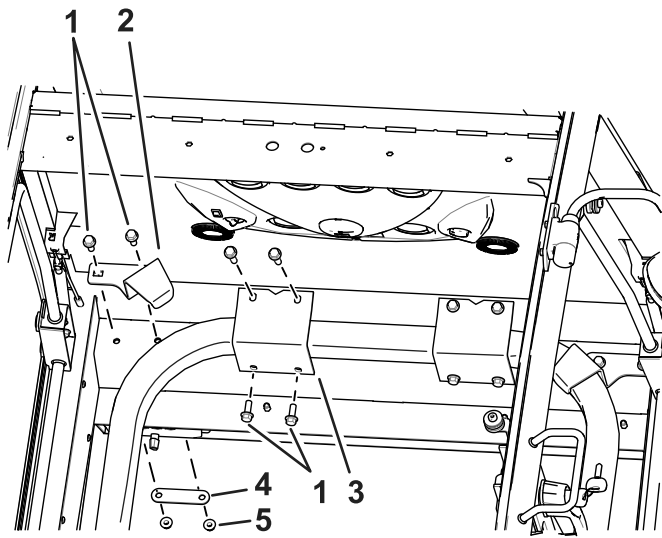

Figure 15

g301843

- | | |
|------------------------|-----------------------|
| 1. Bolt (3/8 x 1 inch) | 4. ROPS brace |
| 2. ROPS stop | 5. Nuts (3/8 inch) |
| 3. ROPS mount | 6. Hardware installed |

Note: Ensure that the ROPS bolts are tightened last (Figure 3).

17. After all the parts and hardware is installed, tighten the hardware.
18. Torque all nuts and bolts attaching the cab to the roll bar to 127 to 157 N·m (94 to 116 ft-lb). Refer to Figure 15
19. Torque the nuts and bolts for the mower deck latch in the front of the cab to 127 to 157 N·m (94 to 116 ft-lb). Refer to Figure 4.
20. Torque the roll bar bolt and nut to 329 to 403 N·m (243 to 297 ft-lb). Refer to Figure 3.
21. Install the cab roof (Figure 11).
22. Install the nut, bolt, and spacer to secure the cable to the traction pedal (Figure 1).

4

Installing the Vent Tubes

Parts needed for this procedure:

2	Bolt (5/16 x 1-1/2 inch)
2	Nut (5/16 inch)
2	Plate clamp
2	Tube clamp

Procedure

1. Install the vent tubes to each side of the cab. Refer to Figure 16.
2. Secure each vent tube with a bolt (5/16 x 1-1/2 inch), a plate clamp, a tube clamp, and a nut (5/16 inch) (Figure 16).

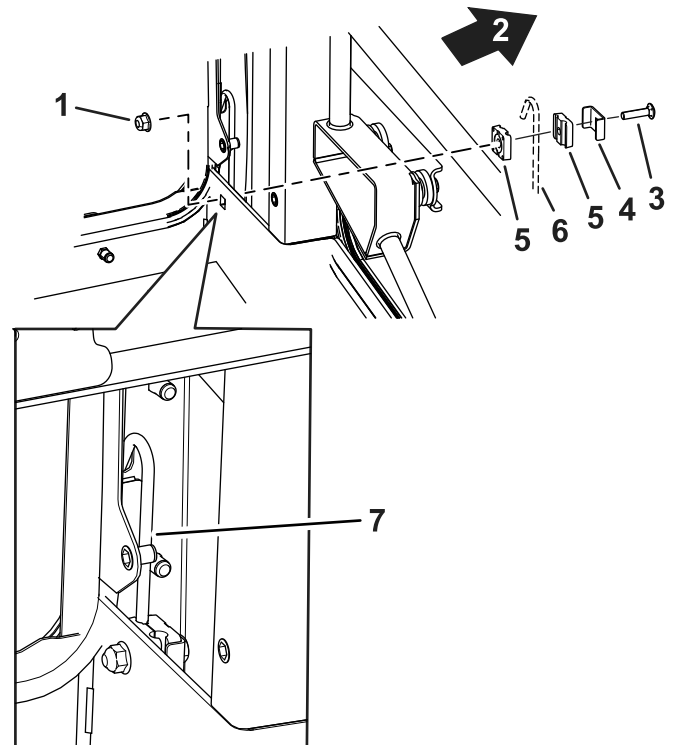

Figure 16

g330010

- | | |
|--------------------------------------------------------|-----------------------------------------------------|
| 1. Nut (5/16 inch) | 5. Tube clamp |
| 2. Left side of the machine (from operator's position) | 6. Vent tube |
| 3. Bolt (5/16 x 1-1/2 inch), | 7. Vent tube installed in the lower left of the cab |
| 4. Plate clamp | |

3. Install the side panels previously removed (Figure 11).

5

Installing the Step

Parts needed for this procedure:

1	Step mount
2	Carriage bolt (3/8 x 7/8 inch)
2	Nut (3/8 inch)
2	Carriage bolt (5/16 x 3/4 inch)
1	Carriage bolt (5/16 x 1-1/4 inch)
3	Nut (5/16 inch)
1	Deck step
1	Floor mat

Procedure

1. Remove the existing step on the side of the machine (Figure 17).

Note: The existing step does not need to be installed when the cab is removed. Use the step that comes with the cab.

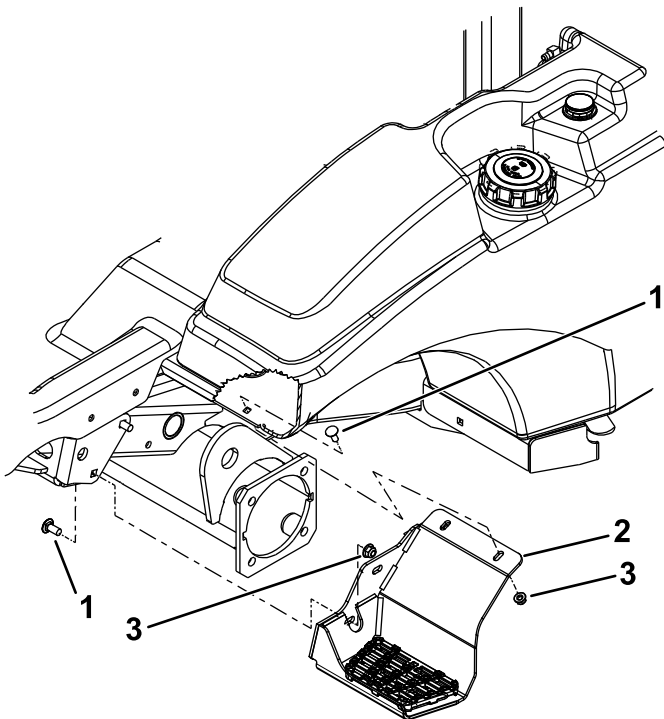

Figure 17

g302817

1. Bolt
2. Step mount
3. Nut

2. Install the deck step to the step mount with a carriage bolt (5/16 x 1-1/4 inch) and a nut (5/16 inch). Refer to Figure 18.
3. Install the step to the side of the machine with 2 carriage bolts (3/8 x 7/8 inches), 2 nuts (3/8 inch), a carriage bolt (3/8 x 7/8 inch), and nut (3/8 inch). Refer to Figure 18.

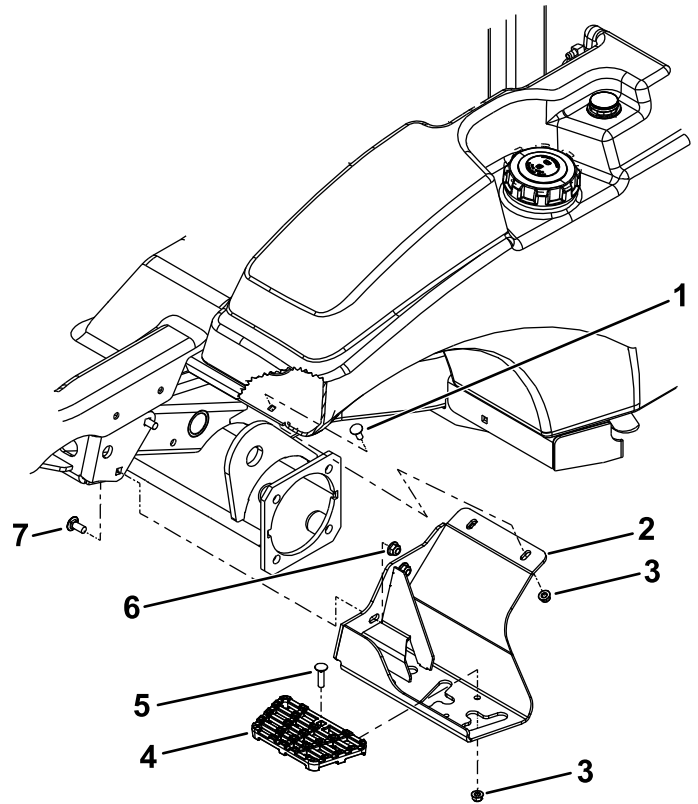
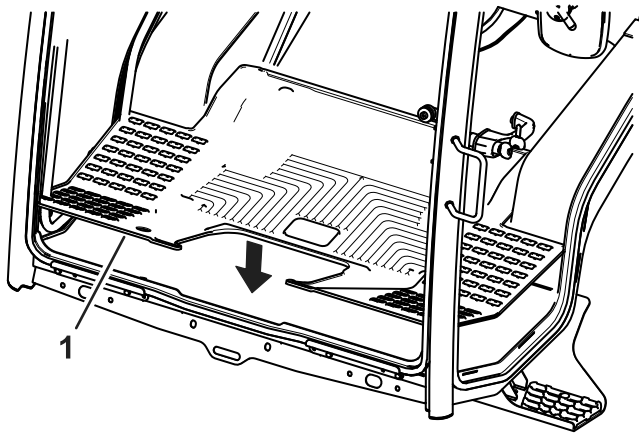

Figure 18

g301516

1. Carriage bolt (5/16 x 3/4 inch)
2. Step mount
3. Nut (5/16 inch)
4. Deck step
5. Carriage bolt (5/16 x 1-1/4 inch)
6. Nut (3/8 inch)
7. Carriage bolt (3/8 x 7/8 inches)

4. Install the floor mat into the cab (Figure 19).



g302840

Figure 19

1. Floor mat

6

Installing the Hoses for the 24 hp Engine

Parts needed for this procedure:

1	Hose
1	Female coupler
1	Female dust plug
2	Straight fitting (3/8 NPT x 5/8 barb)
4	Hose clamp
1	Male coupler
1	Male dust plug
2	R-clamp
2	Carriage bolt (1/4 x 3/4 inch)
2	Flange nut (1/4 inch)
2	Engine fitting
8	Cable ties
1	Straight adaptor (3/8 inch)
1	Adaptor (M16)

Procedure

1. Apply sealant to the straight fittings (3/8 NPT x 5/8 barb), skipping the first thread.
2. Slip hose clamps over the hoses.
3. Slip the dust plug and dust cap over the barbed end of the assemblies (Figure 20).
4. Thread the straight fittings (3/8 NPT x 5/8 barb) into the male and female couplers (Figure 20).
5. Tighten the straight fittings (3/8 NPT x 5/8 barb) in the male and female couplers 2 to 3 turns from finger-tight.
6. Insert the barbed end of the assemblies into the hoses and secure them with the hose clamps (Figure 20).
7. Install the straight adaptor (3/8 inch) onto the engine fitting for the hose with the male coupler (Figure 20).
8. Install the straight adaptor (M16) onto the engine fitting for the hose with the female coupler (Figure 20).

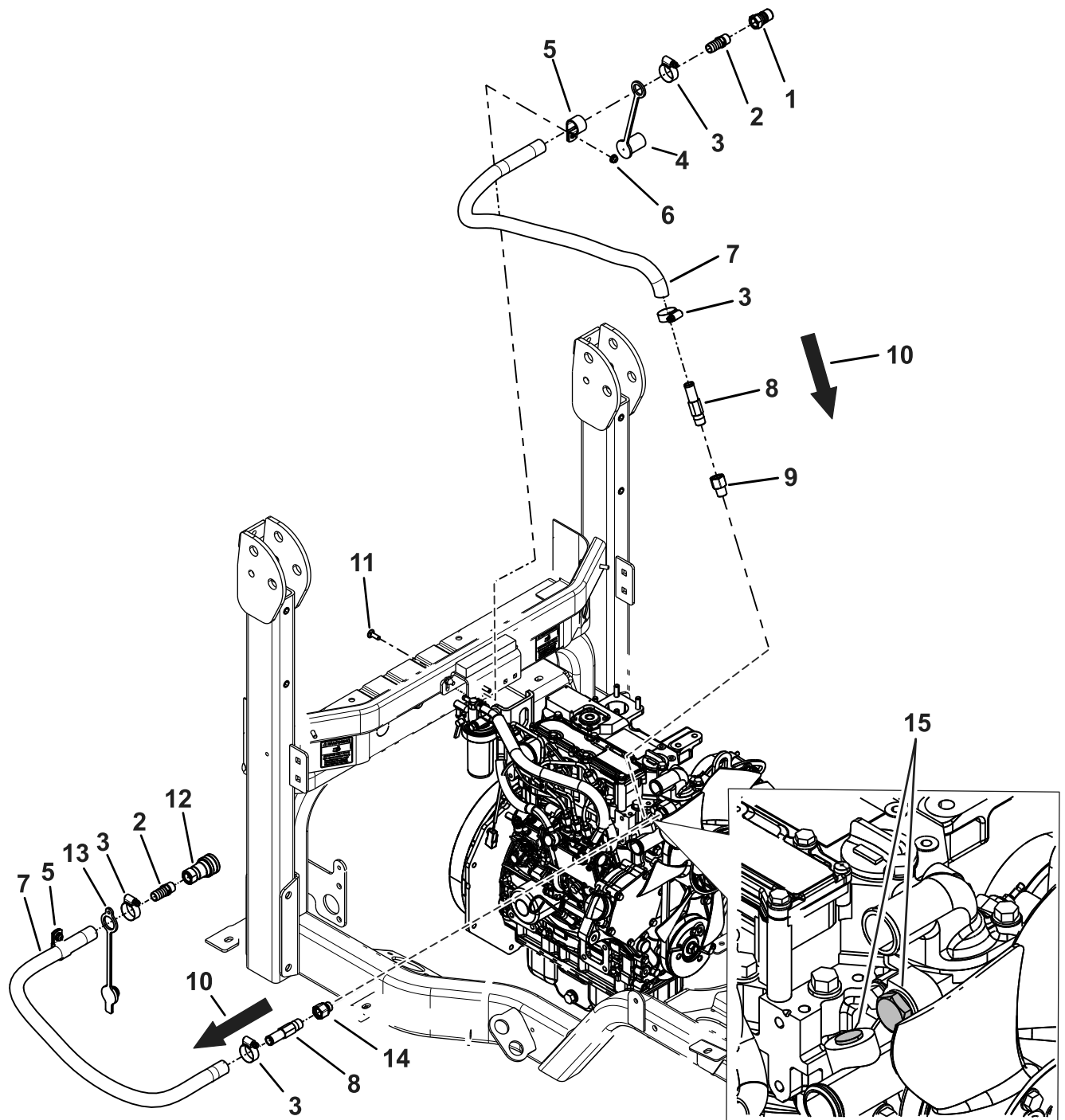

Figure 20

g301831

- | | | |
|------------------------------------------|--------------------------------|------------------------------------|
| 1. Male coupler | 6. Nut (1/4 inch) | 11. Carriage bolt (1/4 x 3/4 inch) |
| 2. Straight fitting (3/8 NPT x 5/8 barb) | 7. Hose | 12. Female coupler |
| 3. Hose clamp | 8. Engine fitting | 13. Female dust plug |
| 4. Dust cap | 9. Straight adaptor (3/8 inch) | 14. Adaptor (M16) |
| 5. R-clamp | 10. Direction of fluid flow | 15. Engine plug |

-
9. Remove the existing bracket from the machine frame and radiator (Figure 21). Save the hardware.

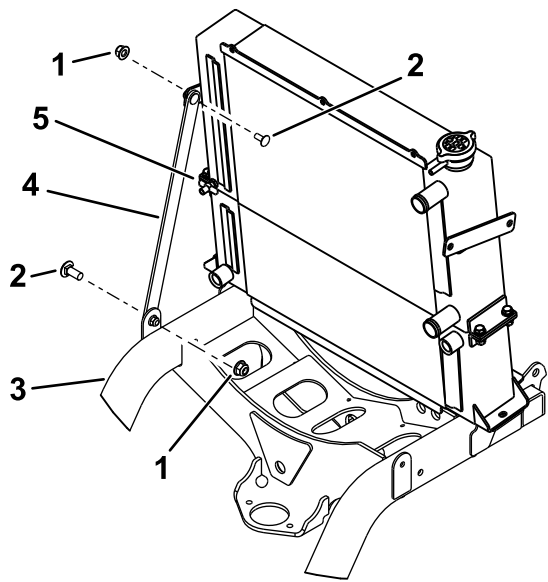

Figure 21

g315428

- | | |
|---------------|---------------------|
| 1. Nut | 4. Existing bracket |
| 2. Bolt | 5. Radiator valve |
| 3. Right side | |

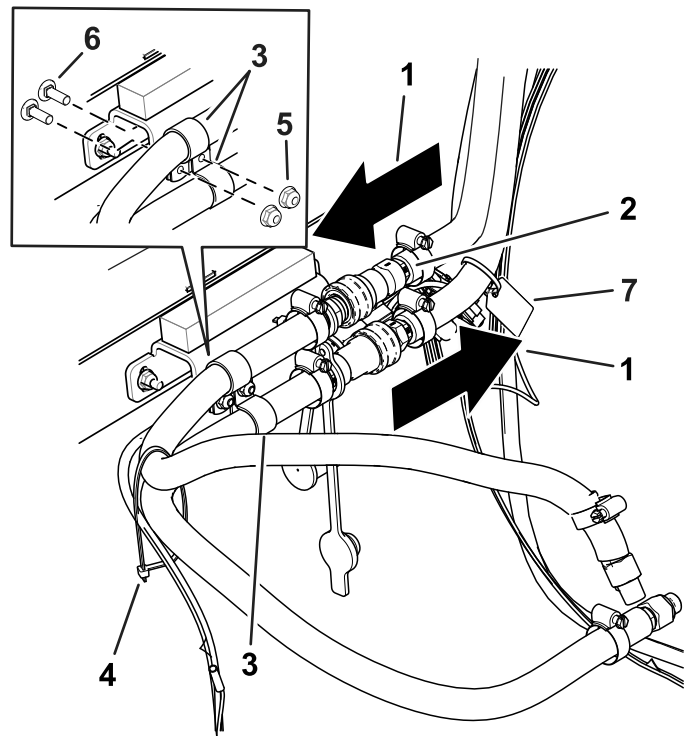

Figure 22

g301828

- | | | |
|-----------------------------------------------------------------------------------------------------------------------------------------------------|-------------------------------------------------------------------------------|-----------------------------------|
| 10. Drain half of the engine coolant from the radiator by using the valve on the right side of the radiator as shown in Figure 21 . | 1. Direction of fluid flow | 5. Nut (1/4 inch) |
| 11. Locate and remove the engine plugs shown in Figure 20 . | 2. Couplers installed | 6. Carriage bolt (1/4 x 3/4 inch) |
| 12. Apply pipe sealant to the threads on the engine fittings. | 3. R-clamp | 7. Tag—noting hot line |
| 13. Manually secure the engine fittings into the ports until they are finger-tight. | 4. Cable tie | |
| 14. Secure the engine fittings 2 to 3 additional turns from finger-tight. | | |
| 15. Slip the hose clamps over the hoses. | | |
| 16. Insert the hoses over the barb ends of the engine fittings and secure them with the hose clamps (Figure 20). | | |
| 17. Install the R-clamps around the hoses (Figure 20). | | |
| 18. Secure the hoses to the back of the cab with 2 carriage bolts and 2 nuts (Figure 20 and Figure 22). | | |
| | 19. Secure the hoses away from moving parts and hot surfaces with cable ties. | |
| | 20. Fill the radiator with engine coolant. | |
| | 21. Start the engine and purge the air out of the cooling system. | |
| | 22. Shut off the engine and check the engine-coolant level. | |
| | 23. If needed, add more engine coolant. | |

Note: When the engine is cold, the coolant level should be no higher than the FULL (COLD) mark (bottom mark).

Note: Refer the traction unit *Operator's Manual* for the correct fluid.

7

Installing the Hoses for the 37 hp Engine

Parts needed for this procedure:

1	Hose
1	Female coupler
1	Female dust plug
2	Straight fitting (3/8 NPT x 5/8 barb)
4	Hose clamp
1	Male coupler
1	Male dust plug
2	R-clamp
2	Carriage bolt (1/4 x 3/4 inch)
2	Flange nut (1/4 inch)
2	Engine fitting
8	Cable ties
1	Straight adaptor (3/8 inch)
1	Adaptor (M16)

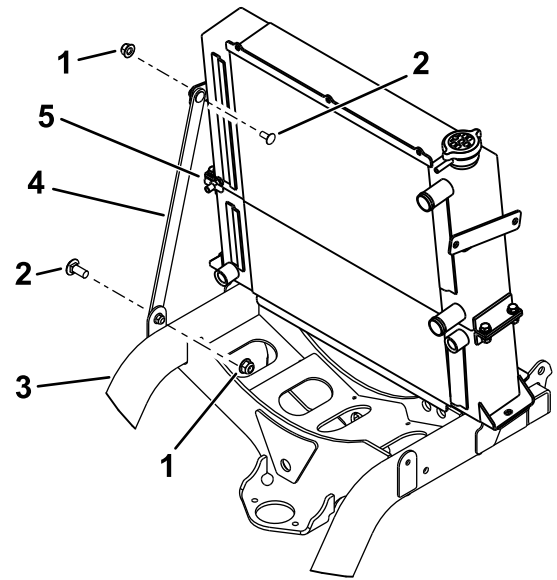

Figure 23

g315428

1. Nut
2. Bolt
3. Right side
4. Existing bracket
5. Radiator valve

8. Drain half of the engine coolant from the radiator by using the valve on the right side of the radiator as shown in [Figure 23](#).
9. Locate and remove the engine plugs shown in [Figure 24](#).

Procedure

1. Apply sealant to the straight fittings (3/8 NPT x 5/8 barb), skipping the first thread.
2. Slip hose clamps over the hoses.
3. Slip the dust plug and dust cap over the barbed end of the assemblies ([Figure 24](#)).
4. Thread the straight fittings (3/8 NPT x 5/8 barb) into the male and female couplers ([Figure 24](#)).
5. Tighten the straight fittings (3/8 NPT x 5/8 barb) in the male and female couplers 2 to 3 turns from finger-tight.
6. Insert the barbed end of the assemblies into the hoses and secure them with the hose clamps ([Figure 24](#)).
7. Remove the existing bracket from the machine frame and radiator ([Figure 23](#)). Save the hardware.

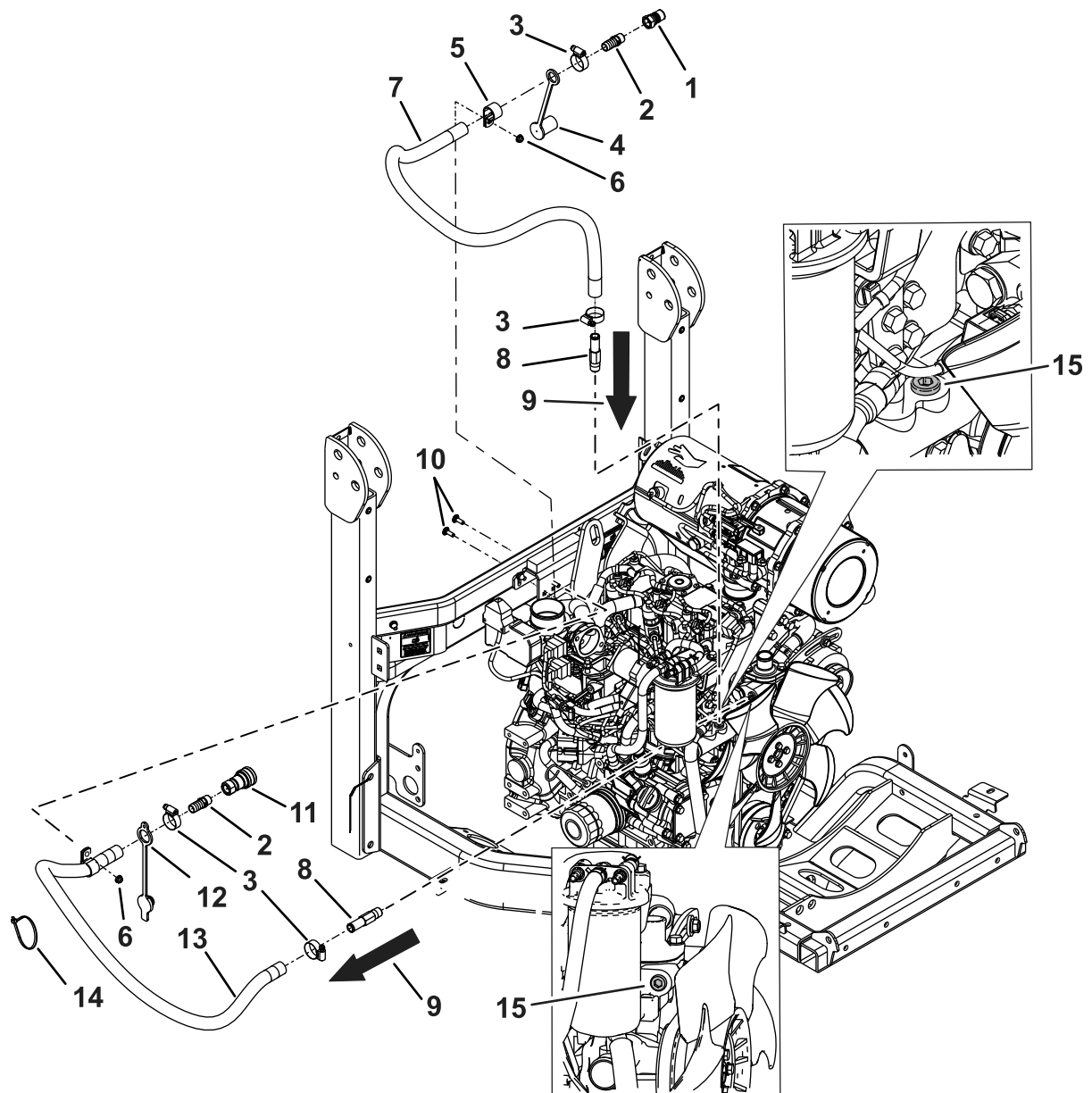

g301830

Figure 24

- | | | |
|------------------------------------------|------------------------------------|----------------------|
| 1. Male coupler | 6. Nut (1/4 inch) | 11. Female coupler |
| 2. Straight fitting (3/8 NPT x 5/8 barb) | 7. Hose | 12. Female dust plug |
| 3. Hose clamp | 8. Engine fitting | 13. Hose |
| 4. Dust cap | 9. Direction of fluid flow | 14. Cable tie |
| 5. R-clamp | 10. Carriage bolt (1/4 x 3/4 inch) | 15. Engine plug |

-
- | | |
|------------------------------------------------------------------------------------------------------------------------------------|-------------------------------------------------------------------------------------------------------------------------------------------|
| 10. Apply pipe sealant to the threads on the engine fittings. | 15. Install the R-clamps around the hoses (Figure 24). |
| 11. Manually secure the engine fittings into the ports until they are finger-tight. | 16. Secure the hoses to the back of the cab with 2 carriage bolts and 2 nuts (Figure 24 and Figure 25). |
| 12. Secure the engine fittings 2 to 3 additional turns from finger-tight. | |
| 13. Slip the hose clamps over the hoses. | |
| 14. Insert the hoses over the barb ends of the engine fittings and secure them with the hose clamps (Figure 24). | |

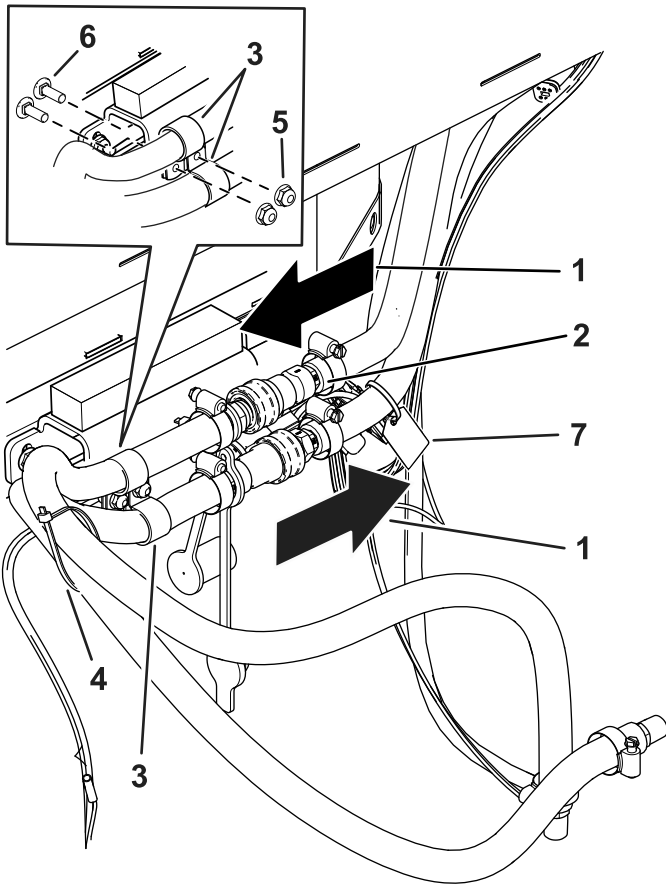

Figure 25

g301829

- | | |
|----------------------------|-----------------------------------|
| 1. Direction of fluid flow | 5. Nut (1/4 inch) |
| 2. Couplers installed | 6. Carriage bolt (1/4 x 3/4 inch) |
| 3. R-clamp | 7. Tag—noting hot line |
| 4. Cable tie | |

17. Secure the hoses away from moving parts and hot surfaces with cable ties (Figure 25).
18. Fill the radiator with engine coolant.
19. Start the engine and purge the air out of the cooling system.
20. Shut off the engine and check the engine-coolant level.
21. If needed, add more engine coolant.

Note: When the engine is cold, the coolant level should be no higher than the FULL (COLD) mark (bottom mark).

Note: Refer the traction unit *Operator's Manual* for the correct fluid.

8

Installing the Washer-Fluid Tank

Parts needed for this procedure:

1	Washer-fluid bracket
1	Washer-fluid tank
4	Carriage bolt (5/16 x 3/4 inch)
4	Locknut (5/16 inch)

Procedure

1. Install the tank to the bracket with 4 carriage bolts (5/16 x 3/4 inch) and 4 nuts (5/16 inch); refer to Figure 26.

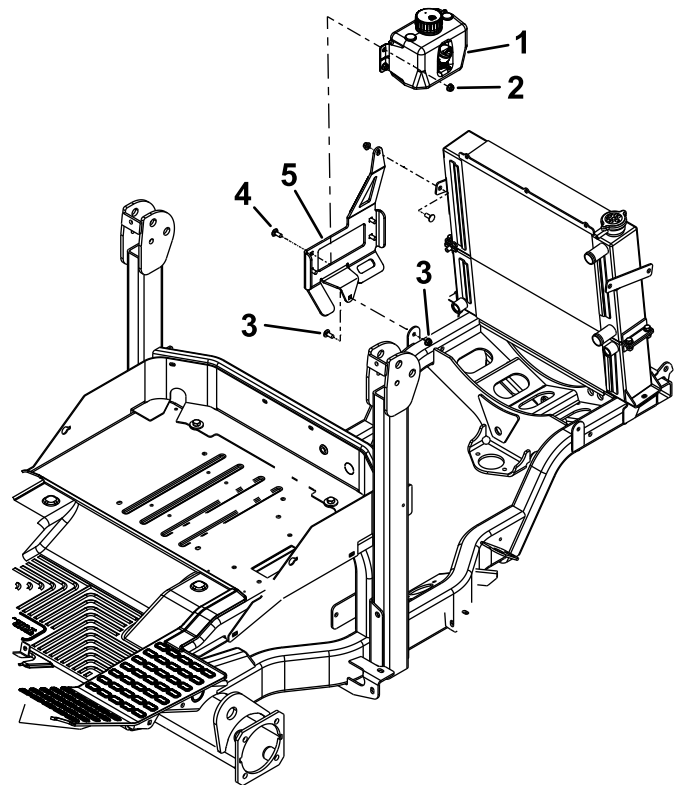

Figure 26

g301514

- | | |
|------------------------|------------------------------------|
| 1. Washer-fluid tank | 4. Carriage bolt (5/16 x 3/4 inch) |
| 2. Locknut (5/16 inch) | 5. Washer-fluid bracket |
| 3. Existing hardware | |

2. Install the tank and bracket to the frame and radiator with the previously removed hardware (Figure 21 or Figure 23).

9

Installing the Washer Fluid Hoses

Parts needed for this procedure:

1	Female-hose fitting
1	Male-hose fitting

Procedure

Note: The hoses are extra long and need to be cut to install the connections.

1. Route the hoses along the frame and back to the washer-fluid tank (Figure 28).
2. Install the hose to the washer-fluid tank as shown in Figure 27.

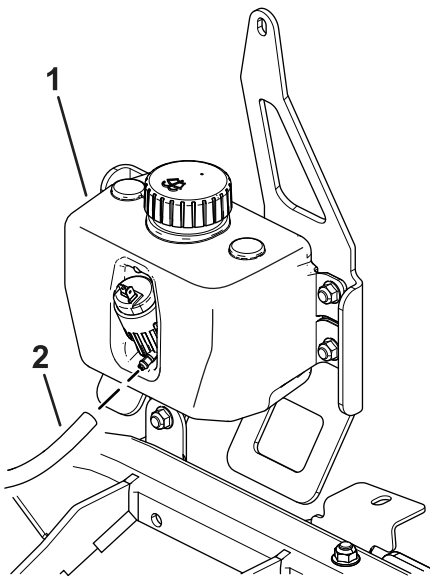

Figure 27

g301599

1. Washer-fluid tank
2. Washer-fluid hose

3. Install the hose to the tank.
4. Cut the hose at the location shown in Figure 28.
5. Install the fittings as shown in Figure 28.

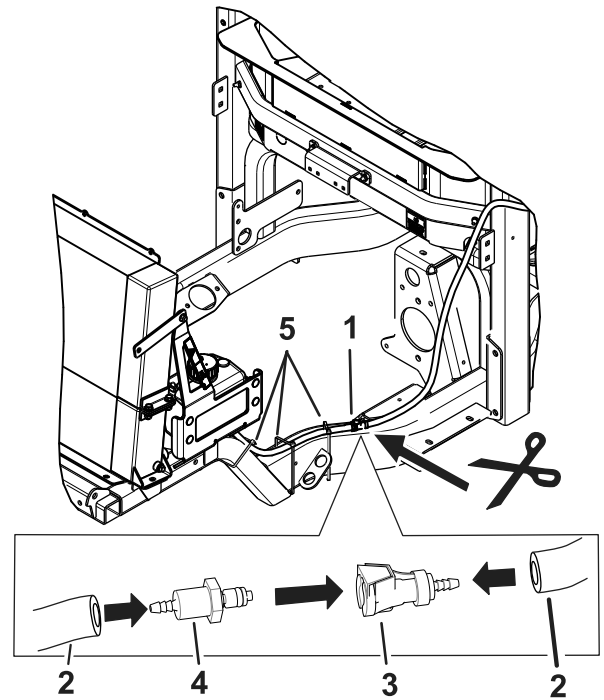

Figure 28

g301541

1. Cut the hose here.
2. Hose end
3. Female fitting
4. Male fitting
5. Plastic ties

6. Secure the hose with plastic ties (Figure 28).

10

Connecting the Wire Harness

Parts needed for this procedure:

1	Fuse (10 A)
---	-------------

Procedure

1. Route the wire harness along the machine frame (Figure 29).

11

Installing the Weights

Parts needed for this procedure:

2	Weight (6 kg or 15 lb)
2	Bolt (3/8 x 3-1/2 inches)
2	Washer (3/8 inch)
2	Locknut (3/8 inch)

Procedure

1. Install 2 weights (6 kg or 15 lb) between the frame and the rear bumper with 2 bolts (3/8 x 3-1/2 inches), 2 washers (3/8 inch), and 2 locknuts (3/8 inch). Refer to [Figure 30](#).
2. If you also install an attachment (e.g., a snow blade, snow broom, or cutting unit), refer to the traction unit *Operator's Manual* for the appropriate amount of rear weight.

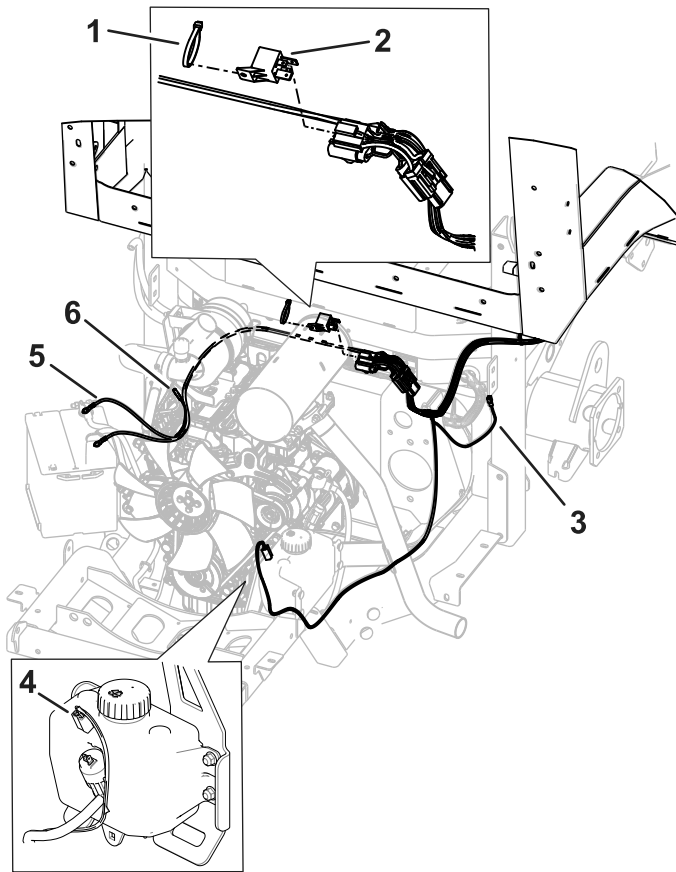

Figure 29

g302187

1. Cable tie
 2. Relay (70 A)
 3. Connect to the main machine harness
 4. Fluid tank connector
 5. Battery terminals
 6. Unused connector
2. Remove the nut that secures the positive-battery clamp to the positive-battery terminal.
 3. Attach the positive-battery terminal from the wire harness to the bolt used to secure the battery clamp.
 4. Secure the clamp with the nut you removed previously.
 5. Repeat the previous steps for the negative battery terminal on the wire harness.
 6. Install the connector to the fluid tank ([Figure 29](#)).
 7. Plug the connector shown in [Figure 29](#) to the main harness of the machine.
 8. Install a fuse (10 A) to the traction-unit fuse block; refer to the electrical-system maintenance section of your traction unit *Operator's Manual* for the appropriate location.

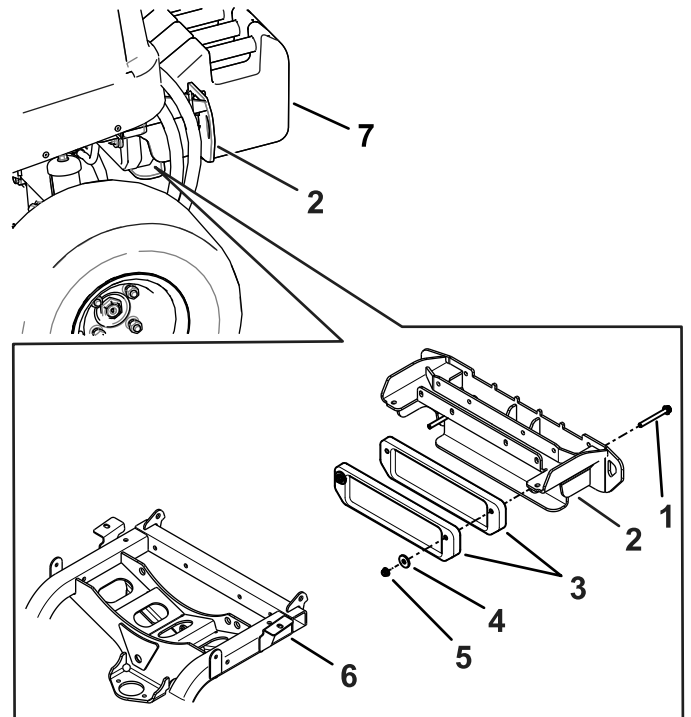

Figure 30

g315463

1. Bolt (3/8 x 3-1/2 inches)
2. Rear bumper
3. 6 kg (15 lb) weights
4. Washer (3/8 inch)
5. Locknut (3/8 inch)
6. Frame
7. 19 kg (42 lb) weights

12

Completing the Installation

No Parts Required

Procedure

1. Check for leaks.
2. Check for parts that interfere with moving parts and make corrections before operating the machine.
3. Connect the negative (-) battery cable to the battery.
4. Check the operation of all controls before operating the machine.
5. Have an assistant help to adjust the rearview and side mirrors before operating the machine.

Product Overview

Controls

Cab Controls

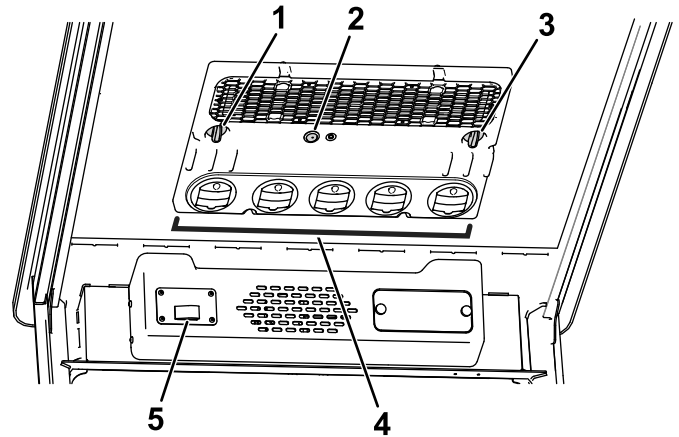

Figure 31

g581885

- | | |
|------------------------|----------------------------|
| 1. Fan control | 4. Air vents |
| 2. Dome light switch | 5. Windshield wiper switch |
| 3. Temperature control | |

- **Fan control knob:** Rotate the fan-control knob to regulate the fan speed.
- **Temperature control knob:** Rotate the temperature-control knob to regulate the air temperature in the cab.
- **Dome light switch:** Use this switch to turn the dome light on or off.
- **Air vents:** Open the vents when the fan is on.
- **Windshield wiper switch:** Use this switch to turn the wipers on or off.

Maintenance

Recommended Maintenance Schedule(s)

Maintenance Service Interval	Maintenance Procedure
After the first 250 hours	• Clean the cab air filters (replace them if they are torn or excessively dirty).

Cleaning

⚠ CAUTION

If you leave the key in the switch, someone could accidentally start the engine and seriously injure you or other bystanders.

Remove the key from the switch before you do any maintenance.

Cleaning the Cab

Important: Use care around the cab seals (Figure 32). If you are using a pressure washer, keep the washer wand at least 0.6 m (2 ft) away from the machine. Do not use the pressure washer directly on the cab seals, glass seals, and under the rear overhang.

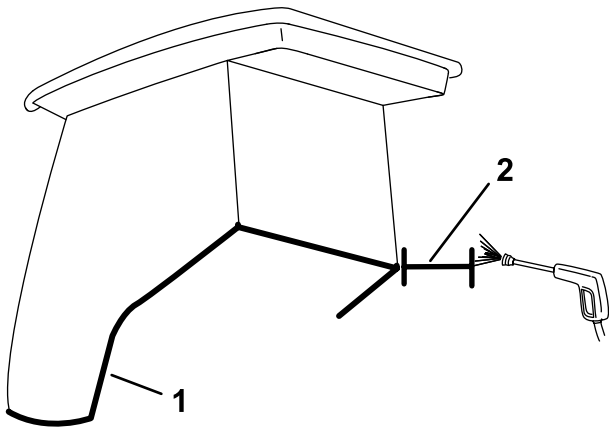

g302075

Figure 32

1. Seal
2. Keep wand 0.6 m (2 ft) away.

Cleaning the Air Filters

Service Interval: After the first 250 hours (replace them if they are torn or excessively dirty).

1. Remove the thumb screws and the grates from the rear cab air filters (Figure 33).

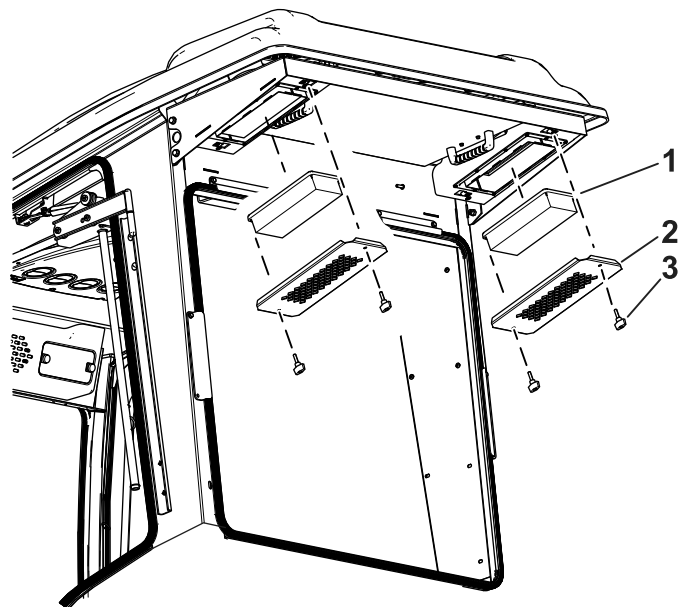

g302176

Figure 33

1. Filter
2. Grate
3. Thumb screw

2. Clean the filters by blowing clean, oil free, compressed air through them.

Important: Replace any damaged filters.

3. Install the filters and grate, securing them with the thumb screws.

Storage

Remove the cab from the machine for storage.

Preparing to Remove the Cab from the Machine

1. Move the machine underneath the cab hoist, shut off the engine, set the parking brake, and remove the key.
2. Allow the engine to cool.
3. Remove the bolt and nut securing traction pedal (Figure 1).
4. Remove the front mower-deck latch from the front of the machine (Figure 4).
5. Remove the bolts from the right armrest and rotate it to the center (Figure 5).
6. Remove the left and right panels inside the cab (Figure 10).
7. Remove the vent tube from each side of the cab behind the panels (Figure 16).
8. Tilt the steering column to its lowest position; refer to the machine *Operators' Manual*.
9. Disconnect the black (-) cable from the battery.

Disconnecting the Wire Harness

1. Disconnect the wire harness secured to the machine from the wire harness secured to the cab at the relay location (Figure 29).
2. Disconnect the connect attached to the main machine harness (Figure 29).
3. Cover the connectors for the machine and cab with tape to keep them clean.

Disconnecting the Hoses

1. Disconnect the washer hose (Figure 20).
2. Disconnect the heater hoses (Figure 34).

Note: Be prepared to collect or wipe the fluid that can drain from the hoses when you disconnect them.

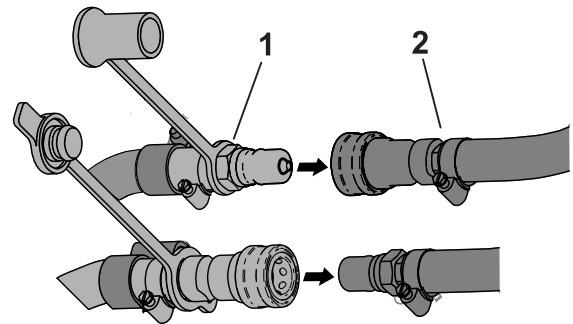

Figure 34

g302188

1. Male coupler
2. Female coupler

3. Seal the heater hoses using the dust caps (Figure 34).

Removing the Cab

1. Remove the cab roof (Figure 11).
2. Remove the ROPS stops and ROPS mounts (Figure 15).

Note: Do not remove the firewall.

3. Remove the covers and roll bar seals from the base of ROPS inside the cab (Figure 14).

Note: Return all the hardware that you removed to the original mounting location in the order it is used to secure the cab to the machine. This can prevent losing the mounting hardware and simplify installation.

4. Install the left and right panels inside the cab (Figure 10).
5. Connect the cab hoist to the 4 lift points on the cab (Figure 12).
6. Raise the cab to a height that will allow you to safely move the machine away from the cab.
7. Move the machine away from the cab.
8. Lower the cab onto the shipping pallet to allow you to move it to a storage location.

Note: Secure the wire harness and hoses to prevent damaging them when you lower or store the cab. Cover the cab to prevent dust and debris from accumulating on it while it is in storage.

9. Move the ROPS pins and bolts back to their original positions (Figure 2 and Figure 3).
10. Torque each bolt to 91 to 113 N·m (67 to 83 ft-lb).
11. Install the bolt and nut securing the traction pedal (Figure 1).
12. Install the front mower-deck latch from the front of the machine (Figure 4).
13. Rotate the armrest into position and Install the bolts (Figure 5).
14. Install the vent tube on each side to the roll bar (Figure 6).

Notes:

Notes:

Notes:



The Toro Warranty

Two-Year or 1,500 Hours Limited Warranty

Conditions and Products Covered

The Toro Company warrants your Toro Commercial product ("Product") to be free from defects in materials or workmanship for 2 years or 1,500 operational hours*, whichever occurs first. This warranty is applicable to all products with the exception of Aerators (refer to separate warranty statements for these products). Where a warrantable condition exists, we will repair the Product at no cost to you including diagnostics, labor, parts, and transportation. This warranty begins on the date the Product is delivered to the original retail purchaser.

* Product equipped with an hour meter.

Instructions for Obtaining Warranty Service

You are responsible for notifying the Commercial Products Distributor or Authorized Commercial Products Dealer from whom you purchased the Product as soon as you believe a warrantable condition exists. If you need help locating a Commercial Products Distributor or Authorized Dealer, or if you have questions regarding your warranty rights or responsibilities, you may contact us at:

Toro Commercial Products Service Department
8111 Lyndale Avenue South
Bloomington, MN 55420-1196

952-888-8801 or 800-952-2740
E-mail: commercial.warranty@toro.com

Owner Responsibilities

As the product owner, you are responsible for required maintenance and adjustments stated in your *Operator's Manual*. Repairs for product issues caused by failure to perform required maintenance and adjustments are not covered under this warranty.

Items and Conditions Not Covered

Not all product failures or malfunctions that occur during the warranty period are defects in materials or workmanship. This warranty does not cover the following:

- Product failures which result from the use of non-Toro replacement parts, or from installation and use of add-on, or modified non-Toro branded accessories and products.
- Product failures which result from failure to perform recommended maintenance and/or adjustments.
- Product failures which result from operating the Product in an abusive, negligent, or reckless manner.
- Parts consumed through use that are not defective. Examples of parts which are consumed, or used up, during normal Product operation include, but are not limited to, brake pads and linings, clutch linings, blades, reels, rollers and bearings (sealed or greasable), bed knives, spark plugs, castor wheels and bearings, tires, filters, belts, and certain sprayer components such as diaphragms, nozzles, flow meters, and check valves.
- Failures caused by outside influence, including, but not limited to, weather, storage practices, contamination, use of unapproved fuels, coolants, lubricants, additives, fertilizers, water, or chemicals.
- Failure or performance issues due to the use of fuels (e.g. gasoline, diesel, or biodiesel) that do not conform to their respective industry standards.
- Normal noise, vibration, wear and tear, and deterioration. Normal "wear and tear" includes, but is not limited to, damage to seats due to wear or abrasion, worn painted surfaces, scratched decals or windows.

Countries Other than the United States or Canada

Customers who have purchased Toro products exported from the United States or Canada should contact their Toro Distributor (Dealer) to obtain guarantee policies for your country, province, or state. If for any reason you are dissatisfied with your Distributor's service or have difficulty obtaining guarantee information, contact your Authorized Toro Service Center.

Parts

Parts scheduled for replacement as required maintenance are warranted for the period of time up to the scheduled replacement time for that part. Parts replaced under this warranty are covered for the duration of the original product warranty and become the property of Toro. Toro will make the final decision whether to repair any existing part or assembly or replace it. Toro may use remanufactured parts for warranty repairs.

Deep Cycle and Lithium-Ion Battery Warranty

Deep cycle and Lithium-Ion batteries have a specified total number of kilowatt-hours they can deliver during their lifetime. Operating, recharging, and maintenance techniques can extend or reduce total battery life. As the batteries in this product are consumed, the amount of useful work between charging intervals will slowly decrease until the battery is completely worn out. Replacement of worn out batteries, due to normal consumption, is the responsibility of the product owner. Note: (Lithium-Ion battery only): Refer to the battery warranty for additional information.

Lifetime Crankshaft Warranty (ProStripe 02657 Model Only)

The Prostripe which is fitted with a genuine Toro Friction Disc and Crank-Safe Blade Brake Clutch (integrated Blade Brake Clutch (BBC) + Friction Disc assembly) as original equipment and used by the original purchaser in accordance with recommended operating and maintenance procedures, are covered by a Lifetime Warranty against engine crankshaft bending. Machines fitted with friction washers, Blade Brake Clutch (BBC) units and other such devices are not covered by the Lifetime Crankshaft Warranty.

Maintenance is at Owner's Expense

Engine tune-up, lubrication, cleaning and polishing, replacement of filters, coolant, and completing recommended maintenance are some of the normal services Toro products require that are at the owner's expense.

General Conditions

Repair by an Authorized Toro Distributor or Dealer is your sole remedy under this warranty.

The Toro Company is not liable for indirect, incidental or consequential damages in connection with the use of the Toro Products covered by this warranty, including any cost or expense of providing substitute equipment or service during reasonable periods of malfunction or non-use pending completion of repairs under this warranty. Except for the Emissions warranty referenced below, if applicable, there is no other express warranty. All implied warranties of merchantability and fitness for use are limited to the duration of this express warranty.

Some states do not allow exclusions of incidental or consequential damages, or limitations on how long an implied warranty lasts, so the above exclusions and limitations may not apply to you. This warranty gives you specific legal rights, and you may also have other rights which vary from state to state.

Note Regarding Emissions Warranty

The Emissions Control System on your Product may be covered by a separate warranty meeting requirements established by the U.S. Environmental Protection Agency (EPA) and/or the California Air Resources Board (CARB). The hour limitations set forth above do not apply to the Emissions Control System Warranty. Refer to the Engine Emission Control Warranty Statement supplied with your product or contained in the engine manufacturer's documentation.