



Installation Instructions

Initial Preparation

1. Unlatch, raise and secure hood with prop rod. Unlatch and remove the left side panel.
2. Remove capscrews securing the battery tray and slide the tray out.
3. Remove the negative (-) battery cable connections from both batteries.



Warning



Wear safety goggles and rubber gloves when working with batteries. Since the gases are explosive, keep open flames and electrical spark away from batteries. Do not smoke.

Remove Plug in Diagnostic Panel

1. Remove plug from hole in front of diagnostic panel (Fig. 1).

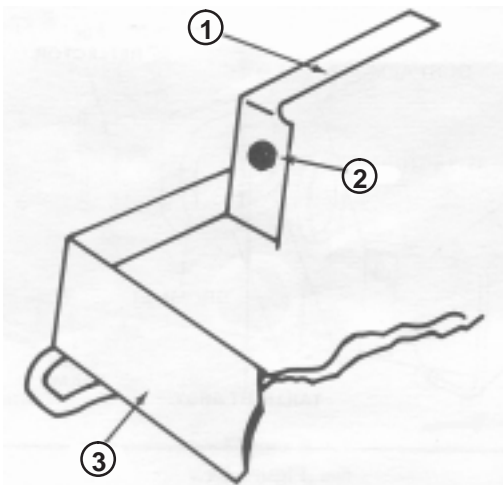

Figure 1

1. Diagnostic panel
2. Plug
3. Main frame

2. Install a rubber grommet (Part No. 240-3) into hole.

Note: It may be necessary to enlarge hole slightly to accommodate the wire harness connector.

Install Light Switch

1. Locate light switch mounting location on the control panel (Fig. 2).
2. Open control panel cover. Using a punch and hammer, knock out plug at mounting hole location. Discard plug.
3. Install light switch in control panel.

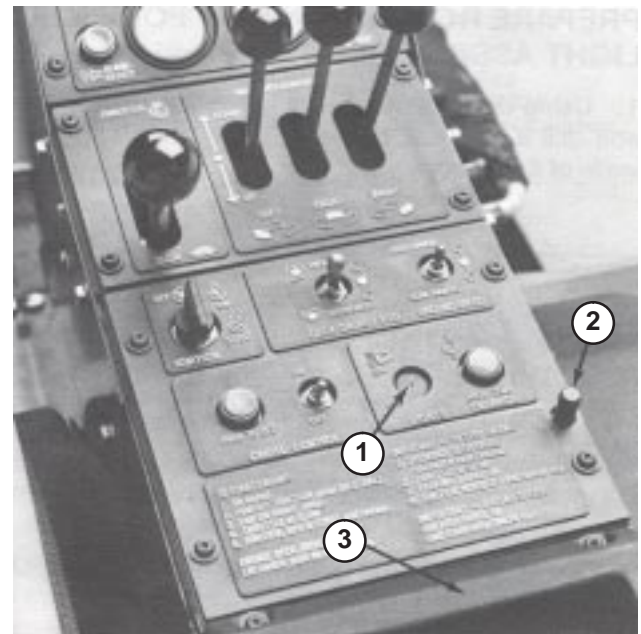

Figure 2

1. Light switch mount hole
2. Control panel lift knob
3. Cup holder assembly

Prepare Radiator Cowl For Amber Light Assemblies

Note: For machines without the Roll-Over Protection (ROPS) option.

1. Remove the upper grille from cowl.
2. Using dimensions shown in figure 3, locate, mark and drill a 17/32" dia. hole in top of cowl. Repeat procedure on opposite side of cowl.

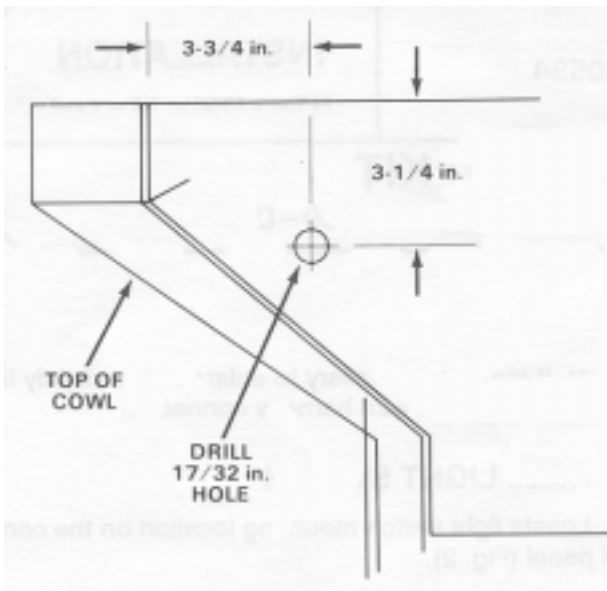

Figure 3

Prepare Bumper for Wire Harness Ties

1. Using dimensions shown in figure 4, locate, mark and drill (3) 1/4" dia. holes in the lower flange of rear bumper.

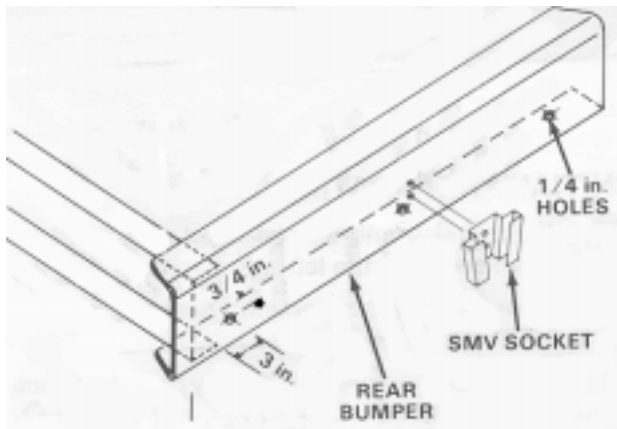

Figure 4

Mount SMV Socket

1. Position SMV socket in the center of rear bumper as shown in figure 4.
2. Using the socket as a template, locate, mark and drill (2) 5/16" dia. holes in center of rear bumper.

3. Mount SMV socket to bumper with (2) 5/16 x 1-1/4" lg. carriage bolts and 5/16 nylon lock nuts.

Assemble and Install Light Arms

1. Mount a 2" red reflector to the end of each light arm with a #10-24 x 1/2" lg. machine screw and a Keps nut (Fig. 5).

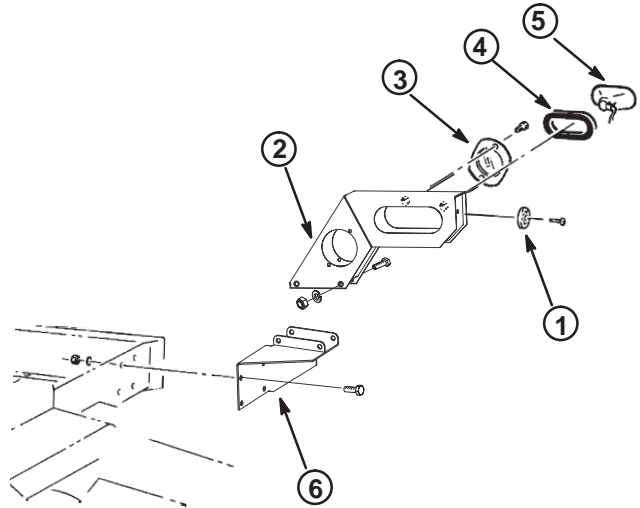

Figure 5

- | | |
|---------------------|------------------------|
| 1. 2" Red reflector | 4. Rubber grommet |
| 2. Light arm | 5. Tail light |
| 3. 3' Red reflector | 6. Light mount bracket |

2. Mount a 3" red reflector to the front of each light arm with (2) #10-24 x 1/2" lg. machine screws and Keps nuts (Fig. 5).
3. In the front of each light arm, install a rubber grommet in each tail light mounting hole (Fig. 5).
4. Install a tail light into each grommet (Fig. 5).
5. Mount a left or right light mount bracket to frame with (4) 3/8-16 x 1" lg. flange head screws, 3/8" lockwashers and 3/8" hex nuts (Fig. 5).

Note: Bracket to be positioned with upper mounting holes to the rear.

6. Mount each light arm to bracket with (2) 3/8-16 x 3-3/4" lg. flange head screws, 3/8" lockwashers and 3/8" hex nuts (Fig. 5).

Mount Fender Reflectors

1. Position a rectangular fender reflector in the center of each fender lip as shown in figure 6.

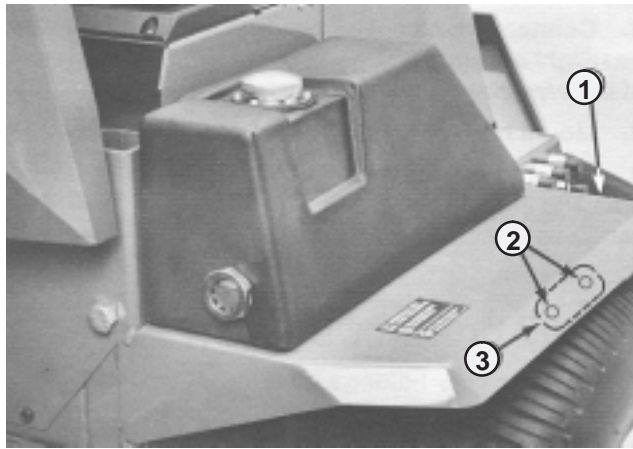

Figure 6

1. Fender
2. Drill 7/32" holes
3. Install reflector

2. Using the reflector as a template, locate, mark and drill (2) 7/32" dia. holes in fender lip.
3. Mount a reflector to each fender with (2) #10–24 x 1/2" lg. machine screws and Keps nuts.

Mount Cutting Unit Reflectors

1. On each front cutting unit, position a round amber reflector on the front outboard corner as shown in figure 7.

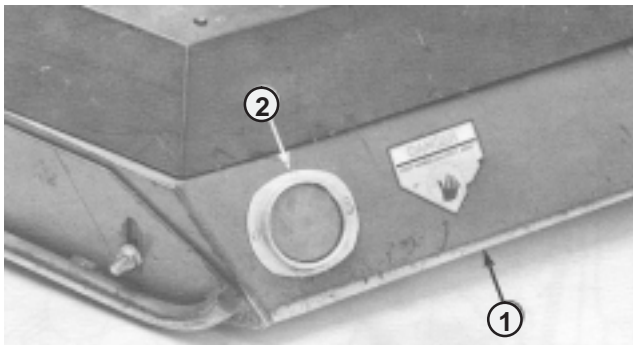

Figure 7

1. Front cutting unit
2. Amber reflector

2. Using the reflector as a template, locate, mark and drill (2) 7/32" dia. holes in cutting unit.
3. Mount a reflector to each cutting unit with (2) #10–24 x 1/2" lg. machine screws and Keps nuts.

Install Hydraulic System Brake Switch

1. Place a drain pan under the hydraulic pump assembly.
2. Remove and discard plug from bottom right side of pump (as viewed from operator's position) (Fig. 8).

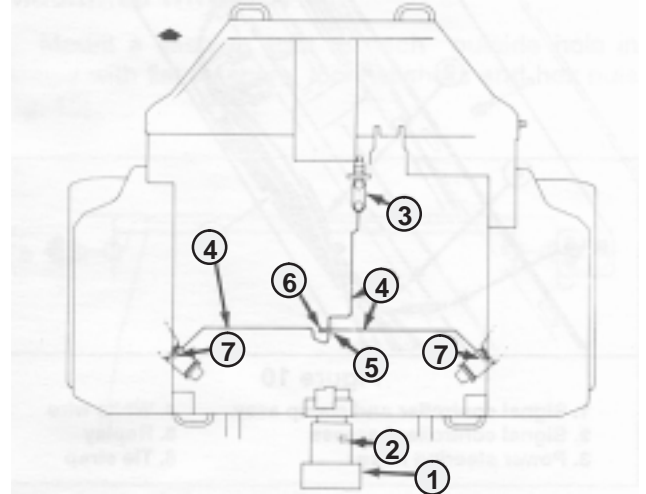

Figure 8

1. Hydraulic pump assembly
2. Remove plug & Install switch.
3. Underside of pump
4. Brake master cylinder
5. Brake lines
6. Tee fitting
7. Brake switch
8. Brake bleed screws

3. Oil the O-ring seal and install the brake switch into the pump. Torque to 19–23 ft.-lb.
4. Connect wire harness connector to hydraulic pump brake switch.

Mount Horn

1. Remove nut securing mounting bracket to horn. Retain nut but discard bracket.
2. Using other horn mounting bracket (included in kit) as a template, locate, mark and drill (2) .38" dia. holes in the floor plate (at right side of the steering tower) (Fig. 9).
3. Secure horn mounting bracket to floor plate with (2) 5/16 x 5/8" screws and nuts (Fig. 9).
4. Plug horn wire harness into horn terminals (Fig. 9).
5. Mount horn to bracket with nut previously removed (Fig. 9).

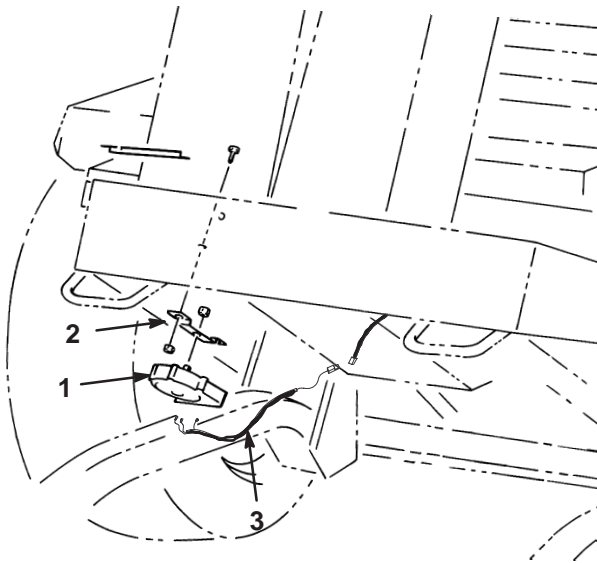

Figure 9

- | | |
|---------------------|----------------------|
| 1. Horn | 3. Horn wire harness |
| 2. Mounting bracket | |

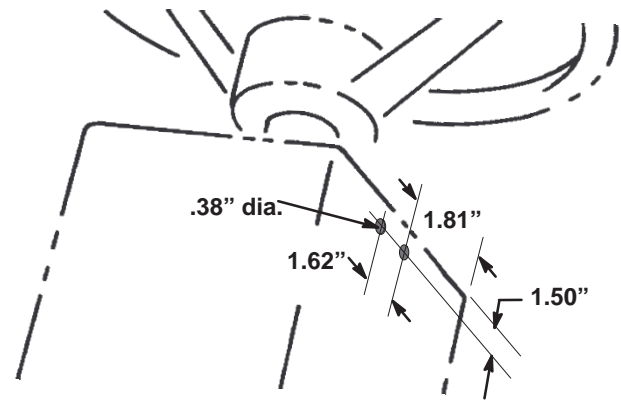

Figure 10

5. Insert signal controller cables through opening in steering tower cover. Install cover to steering tower with (4) screws previously removed.
6. Mount signal controller to mounting bracket with (2) filister head screws and washers, positioning as shown in figure 11

Install Signal Controller and Relay

1. Remove front of steering tower.
2. Remove (4) screws securing cover to top of steering tower.
3. On machines with serial numbers greater than 230000001, proceed to step 4. On machines with serial numbers prior to 229999999, proceed to step 8.
4. Using dimensions shown in figure 10, locate, mark and drill (2) .38" dia. holes in left side of steering tower.

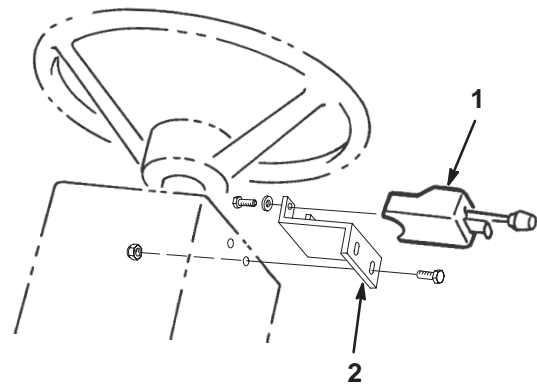

Figure 11

- | | |
|----------------------|---------------------|
| 1. Signal controller | 2. Mounting bracket |
|----------------------|---------------------|

7. Secure mounting bracket to steering tower with (2) screws and nuts (Fig. 11). Proceed to step 10.
8. Insert signal controller cables through opening in steering tower cover. Install cover to steering tower with (4) screws previously removed.
9. Position signal controller on left side of steering column. Install clamp on right side and tighten, securing controller to column (Fig. 12).
10. Bundle the excess cables together and secure it to a power steering hose with cable ties.

11. Where signal controller harness passes thru steering tower panel, secure it to steering column, so it does not make contact with moving steering column.
12. Cut eyelet connector off white wire and strip back insulation approximately 3/8".
13. Cut shrink tubing into 2" lengths and use for butt connectors.
14. Slip shrink tubing over wires, secure controller wires to matching harness wires with butt connectors. Connect white controller wire to black wire w/white stripe on wire harness. Crimp connectors and seal with shrink tubing.

Note: Use cable ties where necessary to prevent the harness from possible damage.

15. Install steering column tower.

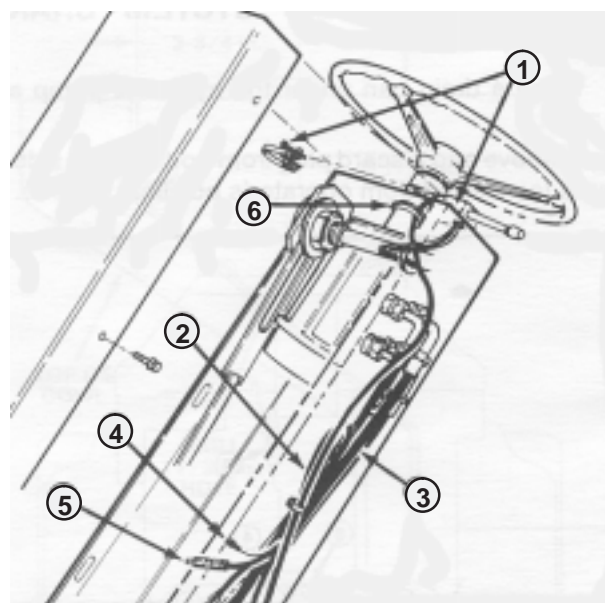

Figure 12

- | | |
|--------------------------------------|---------------|
| 1. Signal controller and clamp assy. | 4. White wire |
| 2. Signal controller harness | 5. Replay |
| 3. Power steering hose | 6. Tie strap |

4. With the control housing removed, connect the horn and headlight wire assembly to the main wire harness inside control housing.
5. Route the wire harness, horn and headlight wires out the grommet in the front of the diagnostic and alongside the right floor plate, then, connect wires to horn switch and headlight assemblies.
6. Connect the blue wire connector to the right hand headlight assembly. The white ground wires go to one of the wire cover mounting screws.
7. Mount horn switch in front shroud assembly.
8. Secure the wire covers to the shroud with 1/4-20 nuts and the cover to the floor plate with 5/16 x 5/8" lg. flange head screws and locknuts.
9. Install trim to top center edge of shroud.

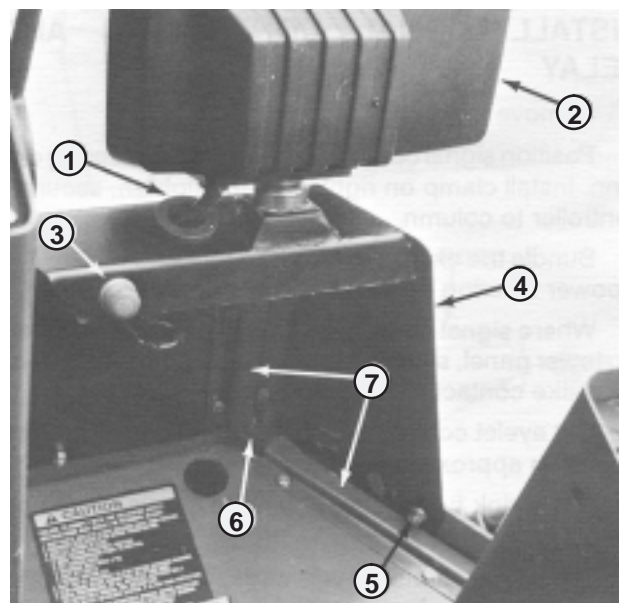

Figure 13

- | | |
|----------------------|------------------------------|
| 1. Grommet | 5. Shroud mounting fasteners |
| 2. Headlight assy. | 6. Wire harness |
| 3. Horn switch assy. | 7. Wire covers (3) |
| 4. Front shroud assy | |

Install Front Shroud Assembly

1. Slide a grommet onto each headlight assembly wire harness. Insert each headlight harness thru appropriate hole in front shroud and install grommet in hole.
2. Mount each headlight to shroud with a flat washer, lock washer and hes nut.
3. Mount shroud assembly to front frame with 5/16 x 5/8" lg. flange head screws and locknuts.

Install Control Box Assemblies

1. Remove cup holder assembly at the rear of the control box assembly.
2. Remove screws from underside of light switch and connect the harness wires to the following:
 - Purple wire from fuse block – to No. 1.
 - Purple wire from warning flasher – No. 2
 - Brown wire from signal flasher – No. 4.

- Dual brown wires – No. 5.

3. Insert the signal and warning flasher assemblies into a harness connector and secure the assemblies to the harness with a wire tie.
4. Insert a 1/4–20 x 1/2” lg. capscrew down through the rear hole in the rear plate. Mount the relays onto the capscrew and secure to the plate with a Keps nut (Fig. 14).

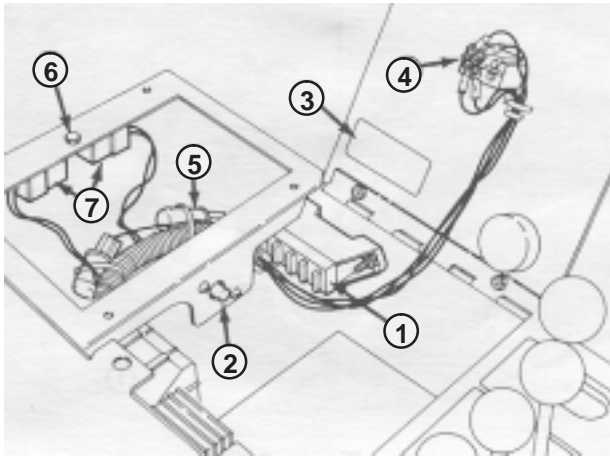

Figure 14

- | | |
|----------------------|-------------------------------------|
| 1. Fuse block | 5. Signal and warning flashers |
| 2. Circuit breaker | 6. Relay mounting capscrews and nut |
| 3. Decal | 7. Relay assemblies |
| 4. Switch connectors | |

5. Connect the wire harness connectors to the relays (Fig. 14).

Note: Use the orange wire with a single connector leading from the warning flasher connector to connect the amber flashing lights in machine with the optional Roll-Over Protection (ROPS) kit and canopy. Use the wire harness normally installed inside the cowl on machines that do not have a ROPS kit installed.

6. Install the cup holder assembly.

Install Amber Flashing Lights (Machines without ROPS)

1. Mount a flashing light to each hole in cowl with flat washers, lockwashers and hex nuts (Fig. 15).

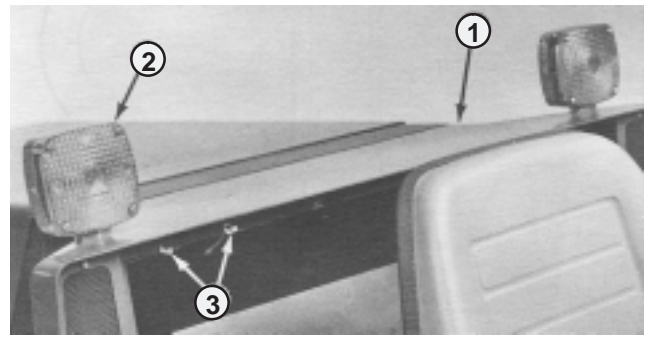

Figure 15

- | | |
|-------------------|---------------|
| 1. Cowl | 3. Wire clips |
| 2. Flashing light | |

2. On engine side of cowl, route harness up the right side of the radiator and through the 1” hole at the top of the cowl (Fig. 16).

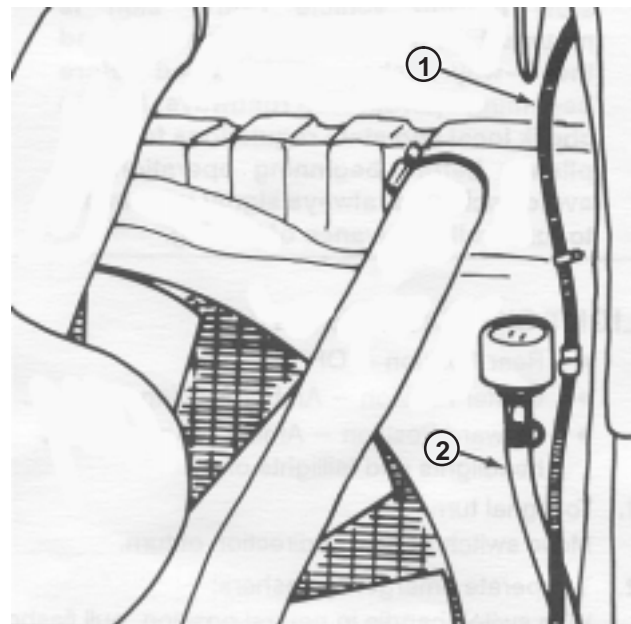

Figure 16

- | | |
|-----------------|------------------|
| 1. Wire harness | 2. Breather tube |
|-----------------|------------------|

3. Connect the harness to each light assembly. Using (4) wire clips, secure the left flashing light harness to the top under side of cowl (Fig. 15).
4. Bundle up any excess wire and secure with wire ties. Install the upper grille in cowl.

Install Amber Flashing Lights (Machines with ROPS)

1. Mount a flashing light to each ROPS post with (2) mounting brackets and fasteners, as shown in figure 17.

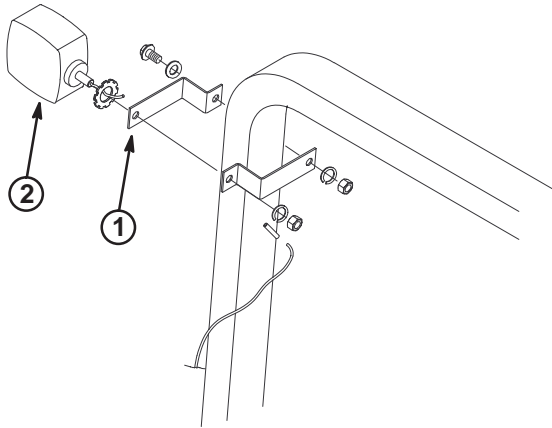

Figure 17

1. Mounting bracket
2. Flashing light

2. Route the harness wire up right side of ROPS frame to the canopy (Fig. 18).

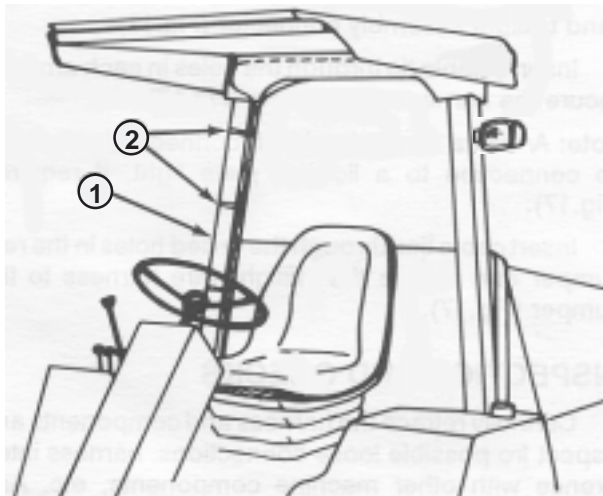

Figure 18

1. ROPS frame
2. Tie straps

3. Insert each harness butt connector through the grommet in the inner walls of the ROPS canopy. Slide a 2" section of shrink tubing over each wire and connect them to the flashing lights (Fig. 18). Seal the connections with the shrink tubing.
4. Use cable ties to secure the harness to the ROPS frame. At rear of canopy, peel the top insulation back slightly and insert wire harness.

Connect Harness to Rear Taillight Assemblies

1. Connect taillight wire assembly connector to main wire harness in rear right hand frame channel (Fig. 19).

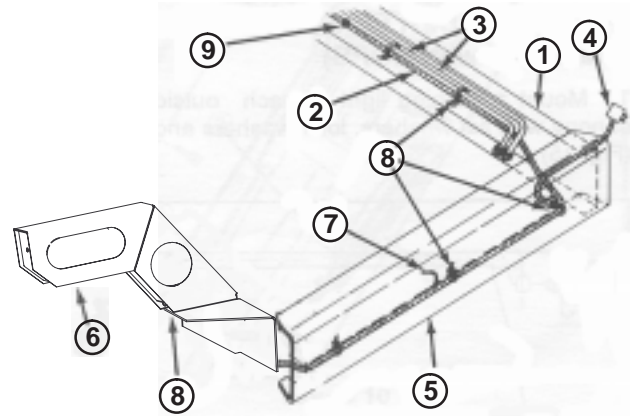

Figure 19

1. R.H. machine frame
2. Wire harness
3. 1 in. steel tubing
4. R.H. taillight connector
5. Back bumper
6. L.H. taillight assy.
7. For license plate light
8. Tie straps
9. Wire harness connection

2. Connect the right hand harness connector to the right hand taillight assembly connector (Fig. 19).
3. Connect the left hand harness connector to the left hand taillight assembly connector (Fig. 19).
4. Install a cable tie through the holes in each arm and secure the harness to the arms (Fig. 19).

Note: An extra brown lead with connector is included for connection to a license plate light, if required (Fig. 19).

5. Insert cable ties through the drilled holes in the rear bumper and secure the taillight wire harness to the bumper (Fig. 19).

Inspection and Checks

- Carefully retrace the harness and components and inspect for possible loose connections, harness interference with other machine components, etc. Add cable ties where needed to necessary corrections.
- Reconnect the negative (-) battery leads to the batteries and check the system for proper function.

Adjust Headlights

1. Loosen the mounting nut and position each headlight so it points straight ahead. Tighten the mounting nuts just enough to hold the headlight in position; proceed to step 2.
2. Place a flat piece of sheet metal, large enough to fit over the three glass protrusions on the face of the headlights, over the headlight (Fig. 20).
3. Mount a magnetic protractor onto the plate (Fig. 20). While holding the assembly in place, carefully tilt the headlight downward 3°, then tighten nut.
4. Repeat procedure on opposite light.

Note: Magnetic protractors are listed in the Toro Commercial Service Tools catalog under Part No. TOR2968.

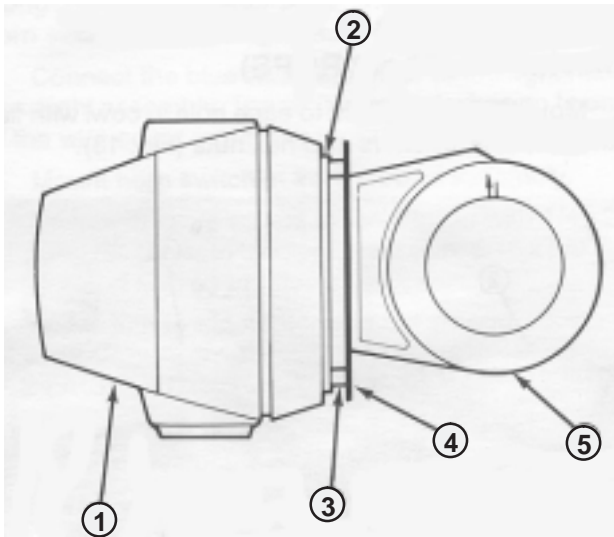

Figure 20

- | | |
|-------------------------|------------------------|
| 1. Headlight assy. | 4. Flat metal plate |
| 2. Headlight lens | 5. Magnetic protractor |
| 3. Glass protrusion (3) | |

Operating Instructions



Warning



To adhere to safety standards, be sure the slow moving vehicle (SMV) sign is mounted on the rear of the machine and the 4-way flashers are actuated before beginning operation on roadways. Always check local and state regulations for compliance before beginning operation. To avoid accidents, always signal your intent to turn well in advance of turning

Light Switch Operation

- Rear Position–OFF
- Center Position–Amber flashing lights on.
- Forward Position–Amber flashing lights, headlights and taillights on.

To signal turns:

- Move switch handle in direction of turn.

To operate emergency flashers:

- With switch handle in neutral position, pull flasher switch out. All signal lamps will flash for all-around vehicle protection.

To release emergency flasher:

- Move switch handle left or right. Flasher will release automatically. Return switch handle to neutral position.

To operate Hi/Lo beams:

- Push handle button in to activate Hi/Lo beams.
- Re-push button to return to regular headlights.

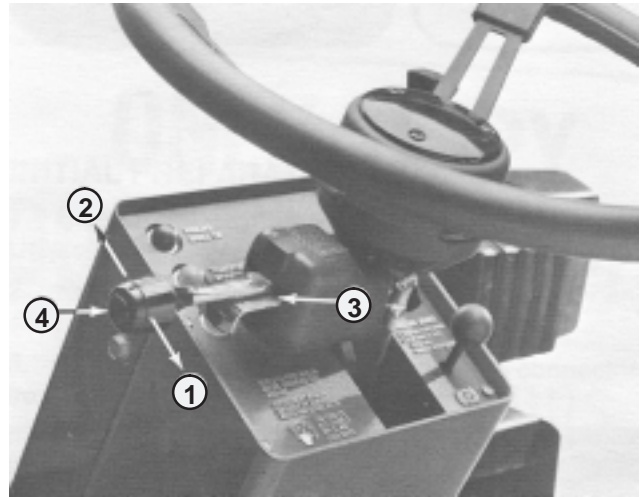

Figure 21

- | | |
|---|--|
| 1. Left turn signal | 4. Hi-Lo headlight beam switch–push in to switch beams |
| 2. Right turn signal | |
| 3. Emergency flasher switch–Pull out to actuate | |

Brake Light Functions

When the service brake is depressed, the brake lights will illuminate. However, the brake lights will also illuminate when the machine is being slowed by action of the hydrostatic transmission or when it is being operated in reverse.