



Spray Gun Kit

Multi-Pro® 5600 Turf Sprayer

Model No. 41580 - 230000001 and up.

Parts Catalog

Ordering Replacement Parts

To order replacement parts, please supply the part number, the quantity, and the description of each part desired.

Understanding Reference Numbers

Each Identified part in an illustration has a reference number. The reference number for a part also appears in the parts list, along with other information about the part.

This catalog uses two special reference number formats, one to indicate parts in a service assembly and another to indicate the quantity of a given part in an illustration.

Service Assembly Reference Numbers

Parts in service assemblies have reference numbers in the form a:b. The a represents the reference number of the entire service assembly and the b represents a sequential number unique to each part within the service assembly.

For example, a wheel assembly might be identified by reference number 6, the tire by 6:1, the valve by 6:2, and the wheel by 6:3. When you order the assembly identified by reference number 6, you receive all parts identified by reference numbers 6:1, 6:2, and 6:3. However, you may also order any part individually. Reference numbers of this type appear in illustrations and in part lists.

Reference Numbers Indicating Quantity

In an illustration, if a reference number indicates more than one part, the reference number has the form nX y. The n represents the quantity of the part, the X is the multiplication symbol, and the y represents the reference number.

For example, in an illustration, the reference number 2X 37 means that two of the parts identified by reference number 37 are indicated.

Contents

Description	Page
Hose and Valve Box Assembly 3
Handgun Assembly No. 100-6733 5
Manifold Assembly No. 106-5096 6
Ball Valve Assembly No. 106-5095 7

Footnotes

- ❶ Not serviced separately

Part Description Abbreviations

Part descriptions in this catalog may include the following abbreviations.

AR.	as required	HYD.	hydraulic
ASM.	assembly	INC.	incorporated
CARR.	carriage	LH.	left hand
DEG.	degrees	NI.	nylon insert
FH.	flat head	PPH.	phillips pan head
GA.	gauge	PTH.	phillips truss head
HF.	hex flange	PTO.	power take off
HH.	hex head	RH.	right hand
HHF.	hex head flange	SFH.	slotted fillister head
HHFTF.	hex head flange thread forming	SHH.	slotted hex head
HJ.	hex jam	SHWH.	slotted hex washer head
HLH.	hex lag head	SPH.	slotted pan head
HOC.	height-of-cut	SQH.	square head
HS.	hex	SRH.	slotted round head
HSBH.	hex socket button head	STD.	standard
HSFH.	hex socket flat head	TAP.	self tapping
HSH.	hex socket head	TTH.	torx truss head
HWH.	hex washer head	WH.	wing head
HWHTF.	hex washer head thread forming		

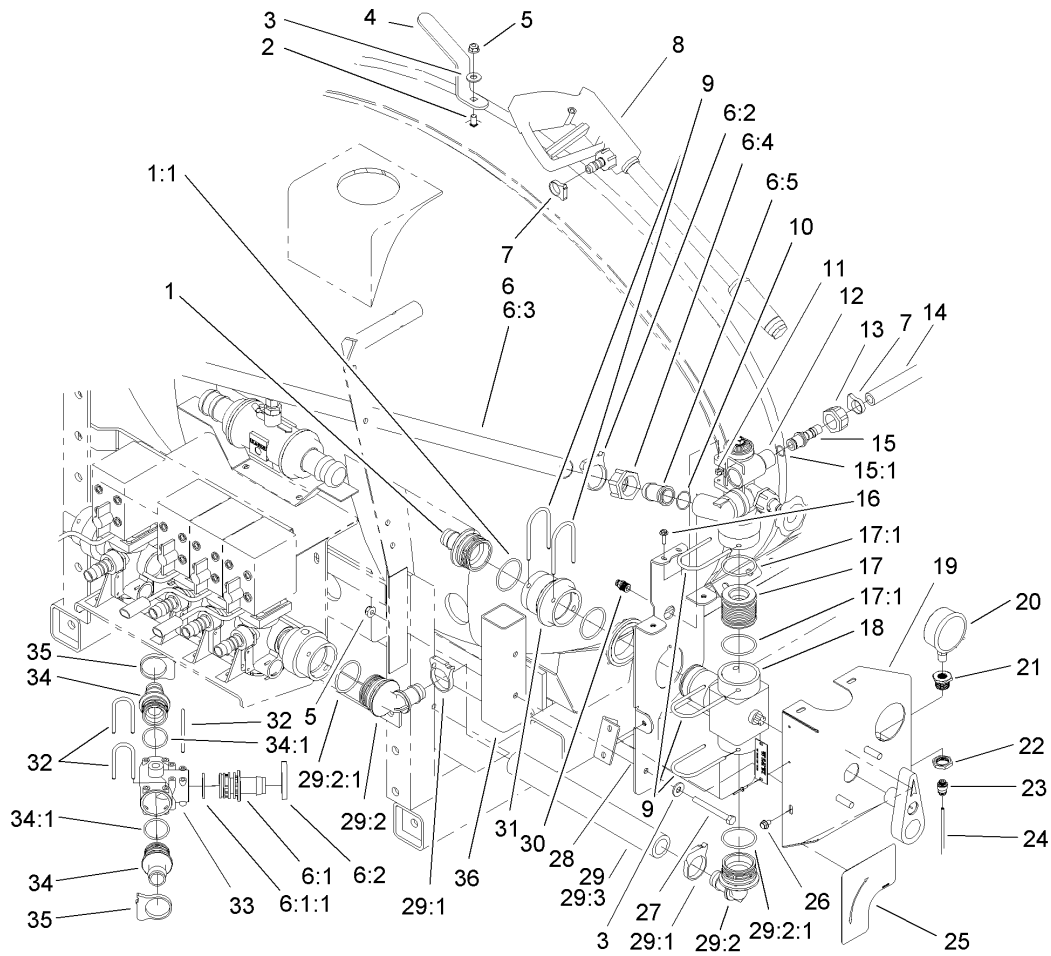

Hose and Valve Box Assembly

Ref	Part No.	Qty.	Description
1	106-4932	1	Hosebarb-Straight
1:1	100-8637	1	O-Ring
2	3230-1	2	Bolt-CARR
3	3256-3	4	Washer-Flat
4	40153	2	Hook-Hose
5	104-8300	4	Nut-Flange, NI
6		1	Hose ASM
6:1	106-4935	1	Hosebarb ASM
6:1:1	100-6712	1	O-Ring
6:2	99-0782	2	Clamp-Hose
6:3	104-8710	1	Hose
6:4	99-0769	1	Nut
6:5	99-0781	1	Hosebarb
7	99-0772	2	Clamp-Hose
8	100-6733	1	Handgun
9	100-8635	5	Fork
10	100-6655	1	Gasket
11	3296-2	2	Nut-Lock
12	106-5096	1	Manifold ASM
13	99-0850	1	Nut
14	107-8751	1	Hose-Spray Gun
15	106-5205	1	Hosebarb ASM
15:1	100-6645	1	O-Ring
16	32105-13	2	Screw-SHH

Ref	Part No.	Qty.	Description
17	106-4947	1	Connector
17:1	100-8637	2	O-Ring
18	106-5095	1	Valve-Ball
19	106-5203-03	1	Cover ASM
20	100-8576	1	Gauge-Pressure
21	100-8665	1	Reducer-Gauge, Pressure
22	100-8666	1	Nut-Reducer
23	100-8667	1	Coupler-Reducer
24	106-5225	1	Tube-Pressure Gauge
25	106-5211	1	Decal-Spray Control
26	3234-26	3	Screw
27	322-14	2	Screw-HH
28	106-5201-03	1	Bracket ASM
29		1	Hose ASM
29:1	99-0782	2	Clamp-Hose
29:2	106-4933	2	Hosebarb ASM
29:2:1	100-8637	1	O-Ring
29:3	106-5224	1	Hose
30	100-8674	1	Coupler-Tube
31	100-7050	1	Bulkhead
32	100-6708	3	Fork
33	104-9041	1	Tee
34	106-4935	2	Hosebarb ASM
34:1	100-6712	1	O-Ring

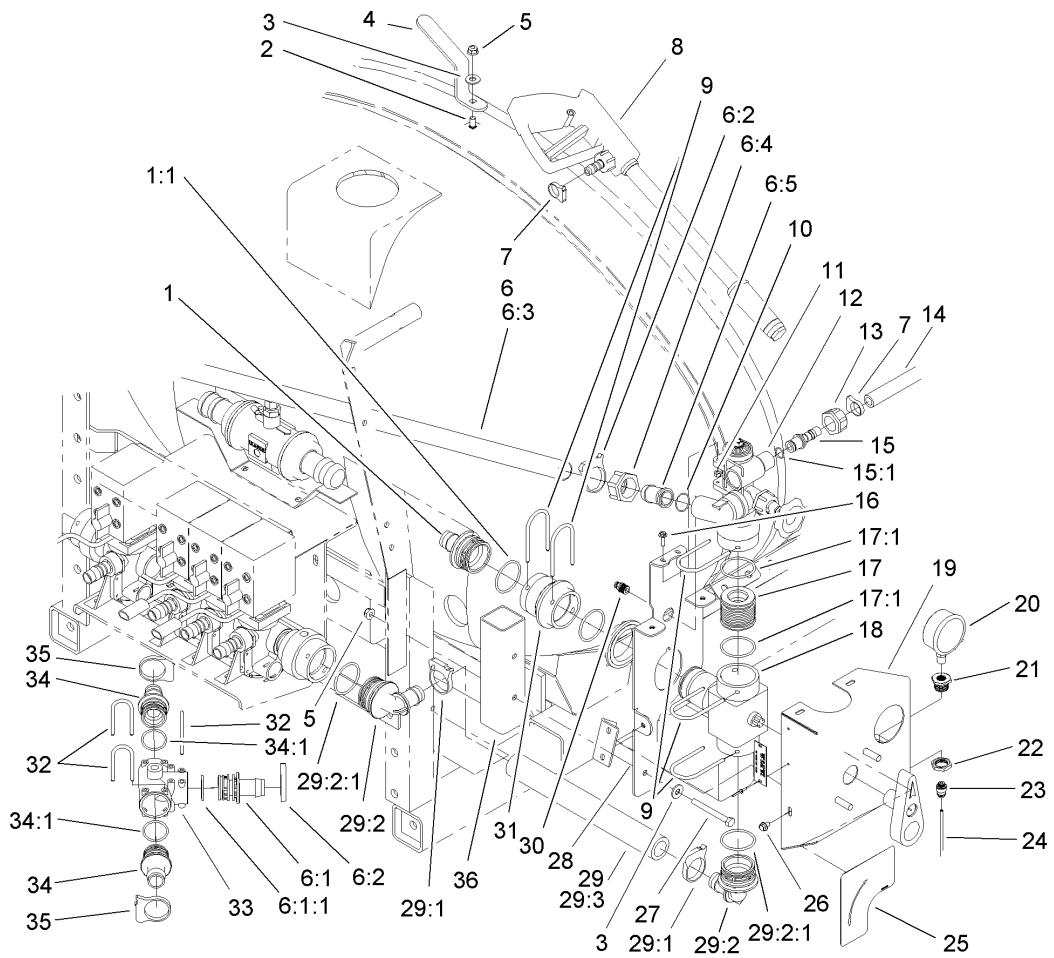

Hose and Valve Box Assembly (continued)

Ref	Part No.	Qty.	Description
35	99-0782	2	Clamp-Hose
36	106-5227-03	1	Tube-Valve Mount

--	--	--	--

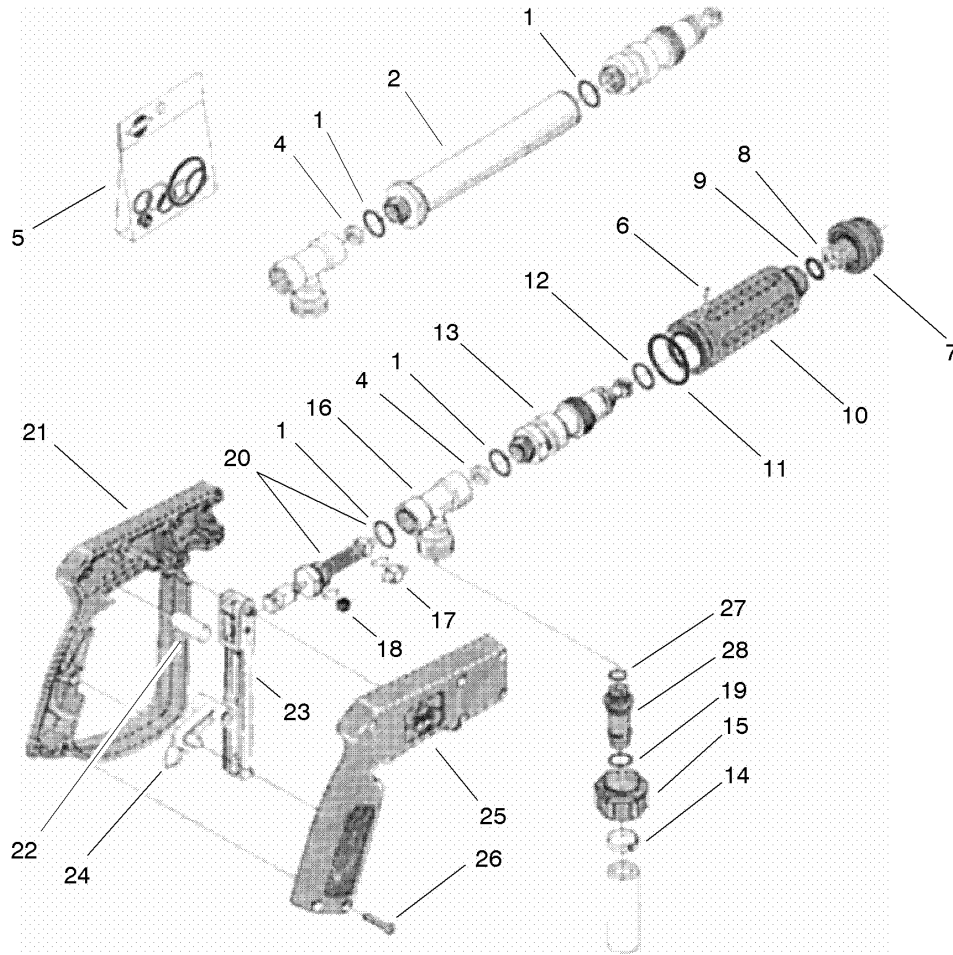

Handgun Assembly No. 100-6733

Ref	Part No.	Qty.	Description
1	100-6649	3	O-Ring
2	99-0885	1	Extension-Lance
4	99-0884	1	Seal-Valve, On/off
5	99-0779	1	Repair Kit
6	99-0887	1	Pin
7	99-0890	1	Housing-Nozzle
8	99-0889	1	Nozzle-Ceramic
9	100-6650	1	O-Ring
10	99-0886	1	Housing-Swirl
11	100-6646	1	O-Ring
12	100-6644	1	O-Ring
13	99-0780	1	Swirl
14	99-0772	1	Clamp-Hose
15	99-0766	1	Nut
16	99-0883	1	Housing-Valve
17	104-8860	1	Cone
18	104-8861	1	Sleeve-Rubber
19	100-6647	1	O-Ring
20	99-0882	1	Valve ASM
21	99-0877	1	Handle-LH
22	99-0878	1	Stop-Rubber, Trigger
23	99-0880	1	Arm-Trigger
24	99-0879	1	Arm-Trigger, Safety
25	99-0881	1	Handle-RH

Ref	Part No.	Qty.	Description
26	100-6666	1	Screw
27	100-6648	1	O-Ring
28	106-5093	1	Hosebarb-Brass

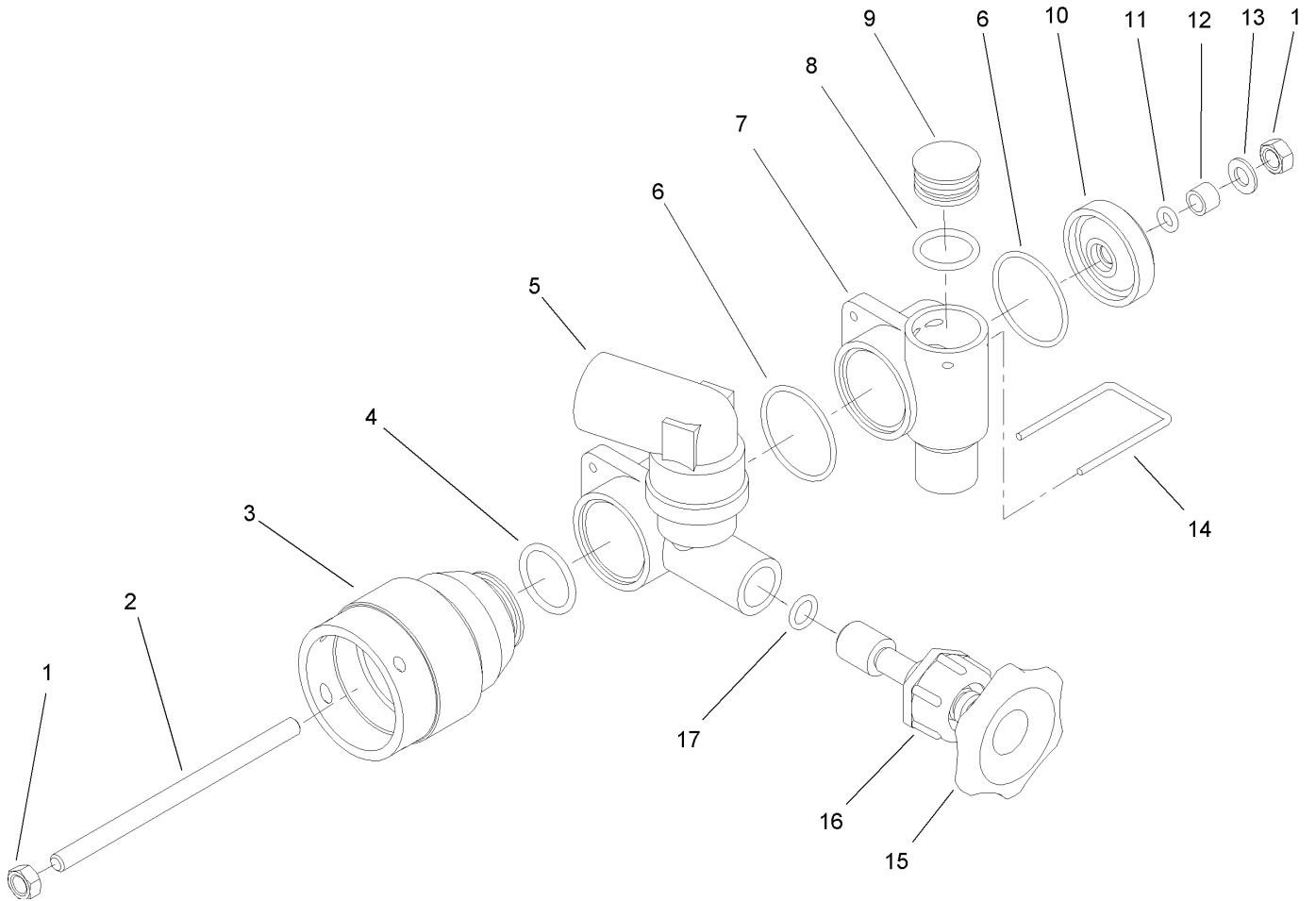

Manifold Assembly No. 106-5096

Ref	Part No.	Qty.	Description
1	100-6894	2	Nut
2	104-8917	1	Rod-Valve, Pressure Control
3	106-1214	1	Connector-Control, Spray
4	100-6646	1	O-Ring
5	104-8919	1	Housing-Pressure Control
6	100-6892	2	O-Ring
7	100-6759	1	Housing-Section Valve
8	100-6882	1	O-Ring
9	100-6891	1	Cap-End
10	100-6913	1	Cover
11	100-6887	1	O-Ring
12	100-6897	1	Bushing
13	100-6634	1	Washer
14	100-6885	1	Fork-Valve, Boom
15	100-6762	1	Regulator-Pressure, Manual
16	99-0850	1	Nut
17	100-6644	1	O-Ring

--	--	--	--

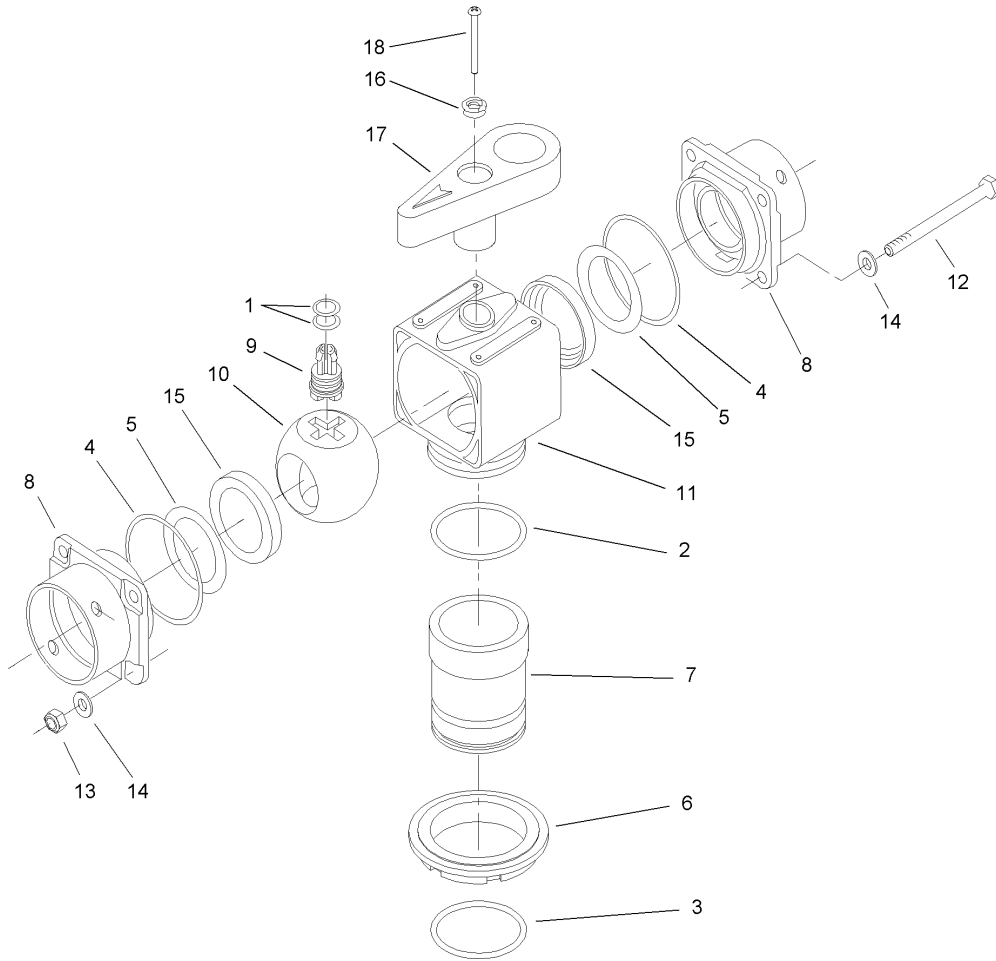

Ball Valve Assembly No. 106-5095

Ref	Part No.	Qty.	Description
1	100-6644	2	O-Ring
2	100-8671	1	O-Ring
3	100-8637	1	O-Ring
4	100-8693	2	O-Ring
5	100-8694	2	O-Ring
6	104-8857	1	Nut
7	104-8858	1	Nipple
8	100-8687	2	Cover-End, 3-Way Valve
9	100-8686	1	Spindle-3 Way Valve
10	100-8697	1	Ball-3 Way Valve
11	106-1323	1	Housing
12	33113-080	4	Screw-HH
13	48-7900	4	Nut
14	100-8692	8	Washer
15	100-8695	2	Seat-Ball
16	100-8682	1	Button
17	106-5207	1	Handle
18	106-5208	1	Screw

