



**Count on it.**

**Operator's Manual**

**Flex-Force Power System® 41cm  
(16in) 60V MAX Chainsaw**

Model No. 51845T—Serial No. 326000000 and Up

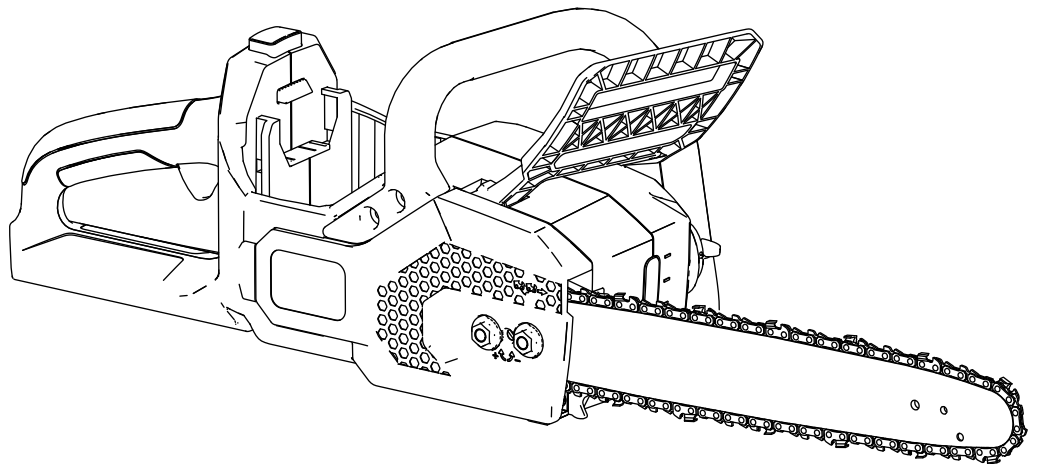

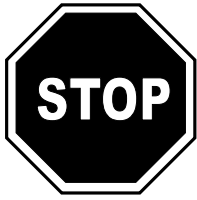

**For assistance, please see [www.Toro.com/support](http://www.Toro.com/support) for instructional videos or contact your Authorized Service Dealer before returning this product.**

**Important:** With your mobile device, you can scan the QR code (if equipped) on the serial number plate to access warranty, parts, and other product information.

This product complies with all relevant European directives; for details, please see the separate product specific Declaration of Conformity (DOC) sheet.

## Introduction

This chain saw is designed for cutting tree branches, logs, and wooden beams of a diameter no longer than the cutting length of the guide bar. It is to be used only by adults. It is designed to use Flex-Force™ 60V lithium-ion battery packs. These battery packs are designed to be charged only by Flex-Force 60V lithium-ion battery chargers. Using these products for purposes other than their intended use could prove dangerous to you and bystanders.

**Model 51845T does not include a battery or a charger.**

Read this information carefully to learn how to operate and maintain your product properly and to avoid injury and product damage. You are responsible for operating the product properly and safely.

Visit [www.Toro.com](http://www.Toro.com) for more information, including safety tips, training materials, accessory information, help finding a dealer, or to register your product.

Whenever you need service, genuine Toro parts, or additional information, contact an Authorized Service Dealer or Toro Customer Service and have the model and serial numbers of your product ready. [Figure 1](#) identifies the location of the model and serial numbers on the product. Write the numbers in the space provided.

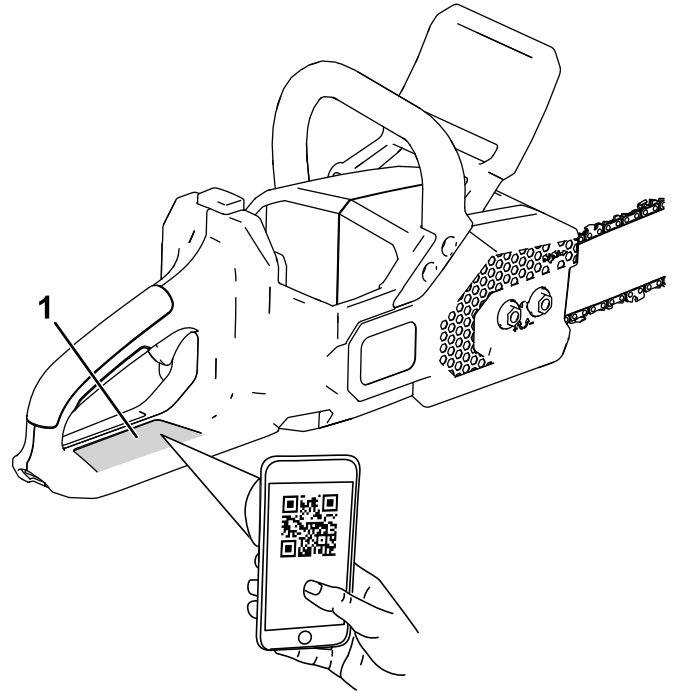

**Figure 1**

g410607

1. Model number, serial number, and QR code location

<p><b>Model No.</b> _____</p> <p><b>Serial No.</b> _____</p>
--

# Safety-Alert Symbol

The safety-alert symbol (Figure 2) shown in this manual and on the machine identifies important safety messages that you must follow to prevent accidents.



**Figure 2**  
Safety-alert symbol

g000502

The safety-alert symbol appears above information that alerts you to unsafe actions or situations and is followed by the word **DANGER**, **WARNING**, or **CAUTION**.

**DANGER** indicates an imminently hazardous situation which, if not avoided, **will** result in death or serious injury.

**WARNING** indicates a potentially hazardous situation which, if not avoided, **could** result in death or serious injury.

**CAUTION** indicates a potentially hazardous situation which, if not avoided, **may** result in minor or moderate injury.

This manual uses two other words to highlight information. **Important** calls attention to special mechanical information and **Note** emphasizes general information worthy of special attention.

# Contents

Safety-Alert Symbol.....	3
Safety .....	4
.....	4
.....	5
Personal Protective Equipment .....	7
Decal Symbols .....	8
Setup .....	9
Filling the Chain Saw with Bar and Chain Oil .....	9
Product Overview .....	9
Specifications .....	9
Attachments/Accessories .....	10
Operation .....	10
Before Using the Chain Saw .....	10
Starting the Chain Saw .....	11
Shutting Off the Chain Saw .....	11
Cutting with the Chain Saw .....	12
Pruning a Tree .....	13
Felling a Tree .....	13
Limbing a Fallen Tree .....	15
Bucking a Log .....	16
Installing the Battery Pack .....	17
Removing the Battery Pack .....	17
Maintenance .....	18
Recommended Maintenance Schedule(s) .....	18
Checking the Oil Level and Adding Bar and Chain Oil .....	18
Checking the Chain Brake .....	19
Checking the Flow of Bar and Chain Oil .....	19
Adjusting the Chain Tension .....	20
Servicing the Guide Bar, Chain, and Drive Sprocket.....	21
Installing the Guide Bar and Chain .....	22
Sharpening the Chain .....	22
Service .....	22
Storage .....	23
Preparing the Battery Pack for Recycling .....	23
Troubleshooting .....	24

# Safety

## ⚠ WARNING

Read all safety warnings, instructions, illustrations and specifications provided with this power tool.

*Failure to follow all instructions listed below may result in electric shock, fire and/or serious injury.*

Save all warnings and instructions for future reference.

*The term “power tool” in all the warnings refers to your mains-operated (corded) power tool or battery-operated (cordless) power tool.*

## IMPORTANT SAFETY INSTRUCTIONS

### I. Work area safety

1. **Keep work area clean and well lit.** *Cluttered or dark areas invite accidents.*
2. **Do not operate power tools in explosive atmospheres, such as in the presence of flammable liquids, gases, or dust.** *Power tools create sparks which may ignite the dust or fumes.*
3. **Keep children and bystanders away while operating a power tool.** *Distractions can cause you to lose control.*

### II. Electrical safety

1. **Power tool plugs must match the outlet. Never modify the plug in any way. Do not use any adapter plugs with earthed (grounded) power tools.** *Unmodified plugs and matching outlets will reduce risk of electric shock.*
2. **Avoid body contact with earthed or grounded surfaces, such as pipes, radiators, ranges and refrigerators.** *There is an increased risk of electric shock if your body is earthed or grounded.*
3. **Do not expose power tools to rain or wet conditions.** *Water entering a power tool will increase the risk of electric shock.*
4. **Do not abuse the cord. Never use the cord for carrying, pulling or unplugging the power tool. Keep cord away from heat, oil, sharp edges or moving parts.** *Damaged or entangled cords increase the risk of electric shock.*
5. **When operating a power tool outdoors, use an extension cord suitable for outdoor use.**

*Use of a cord suitable for outdoor use reduces the risk of electric shock.*

6. **If operating a power tool in a damp location is unavoidable, use a residual current device (RCD) protected supply.** *Use of an RCD reduces the risk of electric shock.*

### III. Personal safety

1. **Stay alert, watch what you are doing and use common sense when operating a power tool. Do not use a power tool while you are tired or under the influence of drugs, alcohol, or medication.** *A moment of inattention while operating power tools may result in serious personal injury.*
2. **Use personal protective equipment. Always wear eye protection.** *Protective equipment such as dust mask, non-skid safety shoes, hard hat, or hearing protection used for appropriate conditions reduces personal injuries.*
3. **Prevent unintentional starting. Ensure the switch is in the OFF-position before connecting to power source and/or battery pack, picking up or carrying the tool. Carrying power tools with your finger on the switch or energizing power tools that have the switch on invites accidents.**
4. **Remove any adjusting key or wrench before turning the power tool on.** *A wrench or a key left attached to a rotating part of the power tool may result in personal injury.*
5. **Do not overreach. Keep proper footing and balance at all times.** *This enables better control of the power tool in unexpected situations.*
6. **Dress properly. Do not wear loose clothing or jewelry. Keep your hair and clothing away from moving parts.** *Loose clothes, jewelry, or long hair can be caught in moving parts.*
7. **If devices are provided for the connection of dust extraction and collection facilities, ensure these are connected and properly used.** *Use of dust collection can reduce dust-related hazards.*
8. **Do not let familiarity gained from frequent use of tools allow you to become complacent and ignore tool safety principles.** *A careless action can cause severe injury within a fraction of a second.*

### IV. Power tool use and care

1. **Do not force the power tool. Use the correct power tool for your application.** *The correct power tool will do the job better and safer at the rate for which it was designed.*
2. **Do not use the power tool if the switch does not turn it on and off.** *Any power tool*

*that cannot be controlled with the switch is dangerous and must be repaired.*

3. **Disconnect the plug from the power source and/or remove the battery pack, if detachable, from the power tool before making any adjustments, changing accessories, or storing power tools.** *Such preventive safety measures reduce the risk of starting the power tool accidentally.*
4. **Store idle power tools out of the reach of children and do not allow persons unfamiliar with the power tool or these instructions to operate the power tool.** *Power tools are dangerous in the hands of untrained users.*
5. **Maintain power tools and accessories. Check for misalignment or binding of moving parts, breakage of parts, and any other condition that may affect the power tool's operation. If damaged, have the power tool repaired before use.** *Many accidents are caused by poorly maintained power tools.*
6. **Keep cutting tools sharp and clean.** *Properly maintained cutting tools with sharp cutting edges are less likely to bind and are easier to control.*
7. **Use the power tool, accessories, and tool bits etc. in accordance with these instructions, taking into account the working conditions and the work to be performed.** *Use of the power tool for operations different from those intended could result in a hazardous situation.*
8. **Keep handles and grasping surfaces dry, clean and free from oil and grease.** *Slippery handles and grasping surfaces do not allow for safe handling and control of the tool in unexpected situations.*

## V. Battery tool use and care

1. **Recharge only with the charger specified by the manufacturer.** *A charger that is suitable for one type of battery pack may create a risk of fire when used with another battery pack.*
2. **Use power tools only with specifically designated battery packs.** *Use of any other battery packs may create a risk of injury and fire.*
3. **When battery pack is not in use, keep it away from other metal objects, like paper clips, coins, keys, nails, screws or other small metal objects, that can make a connection from one terminal to another.** *Shorting the battery terminals together may cause burns or a fire.*
4. **Under abusive conditions, liquid may be ejected from the battery; avoid contact. If contact accidentally occurs, flush with water. If liquid contacts eyes, additionally seek**

**medical help.** *Liquid ejected from the battery may cause irritation or burns.*

5. **Do not use a battery pack or tool that is damaged or modified.** *Damaged or modified batteries may exhibit unpredictable behavior resulting in fire, explosion or risk of injury.*
6. **Do not expose a battery pack or tool to fire or excessive temperature.** *Exposure to fire or temperature above 130 °C (265 °F) may cause explosion.*
7. **Follow all charging instructions and do not charge the battery pack or tool outside the temperature range specified in the instructions.** *Charging improperly or at temperatures outside the specified range may damage the battery and increase the risk of fire.*

## VI. Service

1. **Have your power tool serviced by a qualified repair person using only identical replacement parts.** *This will ensure that the safety of the power tool is maintained.*
2. **Never service damaged battery packs.** *Service of battery packs should only be performed by the manufacturer or authorized service providers.*

## VII. Chain saw safety

1. **Keep all parts of the body away from the saw chain when the chain saw is operating. Before you start the chain saw, make sure the saw chain is not contacting anything.** *A moment of inattention while operating chain saws may cause entanglement of your clothing or body with the saw chain.*
2. **Always hold the chain saw with your right hand on the rear handle and your left hand on the front handle.** *Holding the chain saw with a reversed hand configuration increases the risk of personal injury and should never be done.*
3. **Hold the chain saw by insulated gripping surfaces only, because the saw chain may contact hidden wiring.** *Saw chains contacting a "live" wire may make exposed metal parts of the chain saw "live" and could give the operator an electric shock.*
4. **Wear eye protection. Further protective equipment for hearing, head, hands, legs and feet is recommended.** *Adequate protective equipment will reduce personal injury from flying debris or accidental contact with the saw chain.*
5. **Do not operate a chain saw in a tree, on a ladder, from a rooftop, or any unstable support.** *Operation of a chain saw in this manner could result in serious personal injury.*

6. **Always keep proper footing and operate the chain saw only when standing on fixed, secure and level surface.** *Slippery or unstable surfaces such as ladders may cause a loss of balance or control of the chain saw.*
7. **When cutting a limb that is under tension, be alert for spring back.** *When the tension in the wood fibers is released, the spring loaded limb may strike the operator and/or throw the chain saw out of control.*
8. **Use extreme caution when cutting brush and saplings.** *The slender material may catch the saw chain and be whipped toward you or pull you off balance.*
9. **Carry the chain saw by the front handle with the chain saw switched off and away from your body. When transporting or storing the chain saw, always fit the guide bar cover and remove the battery.** *Proper handling of the chain saw will reduce the likelihood of accidental contact with the moving saw chain.*
10. **Follow instructions for lubricating, chain tensioning, and changing the bar and chain.** *Improperly tensioned or lubricated chain may either break or increase the chance for kickback.*
11. **Cut wood only. Do not use chain saw for purposes not intended. For example: do not use chain saw for cutting metal, plastic, masonry or non-wood building materials.** *Use of the chain saw for operations different than intended could result in a hazardous situation.*
12. **Do not attempt to fell a tree until you have an understanding of the risks and how to avoid them.** *Serious injury could occur to the operator or bystanders while felling a tree.*
13. **Follow all instructions when clearing jammed material, storing or servicing the chain saw. Make sure the switch is off and the battery pack is removed.** *Unexpected actuation of the machine while clearing jammed material or servicing may result in serious personal injury.*
14. **Causes and operator prevention of kickback.** *Kickback may occur when the nose or tip of the guide bar touches an object, or when the wood closes in and pinches the saw chain in the cut.*  
  
*Tip contact in some cases may cause a sudden reverse reaction, kicking the guide bar up and back towards the operator.*  
  
*Pinching the saw chain along the top of the guide bar may push the guide bar rapidly back towards the operator.*  
  
*Either of these reactions may cause you to lose control of the saw, which could result in serious personal injury. Do not rely exclusively upon the*

*safety devices built into your saw. As a chain saw user, you should take several steps to keep your cutting jobs free from accident or injury.*

*Kickback is the result of chain saw misuse and/or incorrect operating procedures or conditions and can be avoided by taking proper precautions as given below:*

- A. **Maintain a firm grip, with thumbs and fingers encircling the chain saw handles, with both hands on the saw and position your body and arm to allow you to resist kickback forces.** *Kickback forces can be controlled by the operator, if proper precautions are taken. Do not let go of the chain saw.*
- B. **Do not overreach and do not cut above shoulder height.** *This helps prevent unintended tip contact and enables better control of the chain saw in unexpected situations.*
- C. **Only use replacement guide bars and saw chains specified by the manufacturer.** *Incorrect replacement guide bars and saw chains may cause chain breakage and/or kickback.*
- D. **Follow the manufacturer's sharpening and maintenance instructions for the saw chain.** *Decreasing the depth gauge height can lead to increased kickback.*

## SAVE THESE INSTRUCTIONS

# Personal Protective Equipment

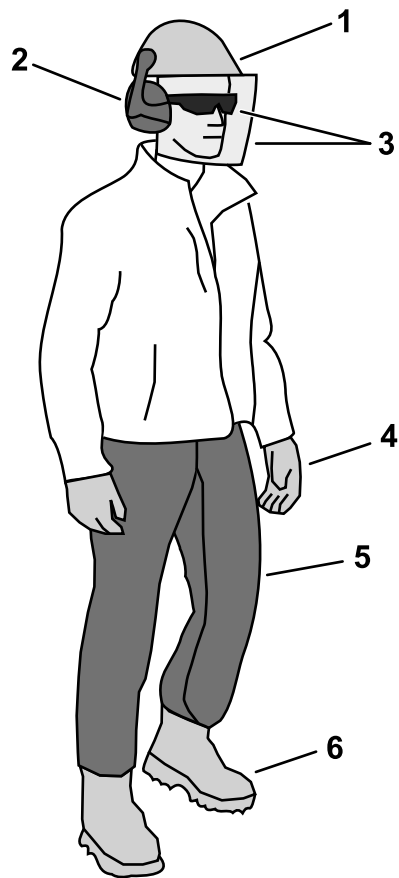

g316566



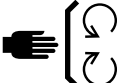







**Figure 3**

- |   |  |
|---|--|
| 1. Wear a hard hat in situations where debris may contact the head. | 4. Wear gloves                               |
| 2. Wear hearing protection  | 5. Wear protective pants or chaps            |
| 3. Wear safety glasses and/or a face shield                         | 6. Wear substantial, slip-resistant footwear |
-

# Decal Symbols



Safety decals and instructions are easily visible to the operator. Replace any decal that is damaged or missing. The following table describes the safety symbols that appear on the decals.

Chain Saw Decal Symbol	Explanation
	Cutting hazard of hand
	Stay away from moving parts.
	Keep all guards and shields in place.
	Kickback hazard
	Do not contact objects with the guide bar tip.
	Do not operate the chain saw using only one hand.
	Do not expose to rain.
	Read the <i>Operator's Manual</i> .
	Wear hearing protection.
	Wear eye protection.
	Always use 2 hands when operating the chain saw.

# Setup

## Filling the Chain Saw with Bar and Chain Oil

**Important:** Use only bar and chain oil (sold separately).

Fill the chain saw with bar and chain oil; refer to [Checking the Oil Level and Adding Bar and Chain Oil](#) (page 18).

# Product Overview

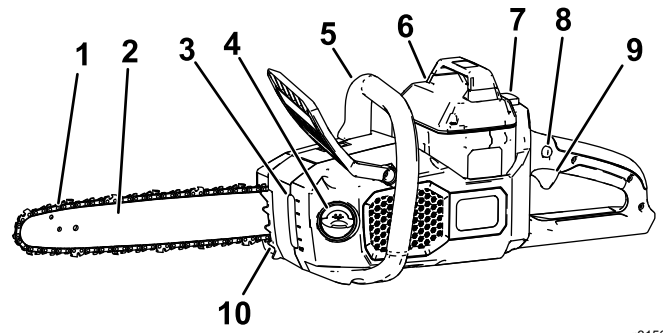

g315699

**Figure 4**

Left side shown

- |                 |                   |
|-----------------|-------------------|
| 1. Chain        | 6. Battery pack   |
| 2. Guide bar    | 7. Button latch   |
| 3. Oil window   | 8. Trigger lock   |
| 4. Oil cap      | 9. Trigger        |
| 5. Front handle | 10. Bucking teeth |

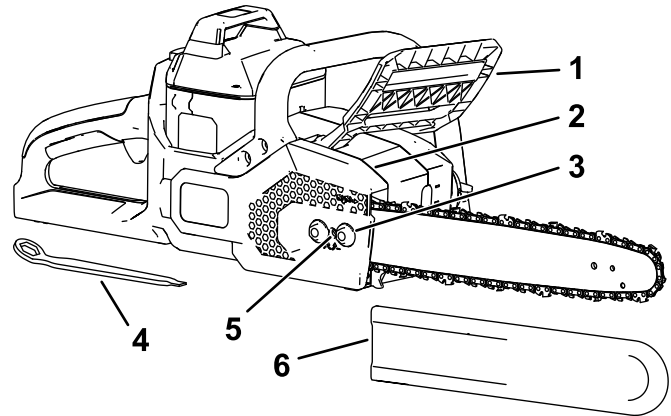

g315700

**Figure 5**

Right side shown

- |                      |  |
|----------------------|--|
| 1. Chain brake       | 4. Multitool (located beneath rear handle) |
| 2. Side cover        | 5. Chain tensioning screw                  |
| 3. Captive cover nut | 6. Guide bar cover                         |

# Specifications

<b>Model</b>	51845T
<b>Bar Length (with 88613 and 88614 equipped)</b>	40.6 cm (16 inches)
<b>Chain Gauge (with 88613 and 88614 equipped)</b>	0.043 inches
<b>Chain Pitch (with 88613 and 88614 equipped)</b>	3/8 inch
<b>Chain Length (with 88613 and 88614 equipped)</b>	56 links

# Operation

## Before Using the Chain Saw

Before using the chain saw, do the following:

- Check the chain tension; refer to [Adjusting the Chain Tension \(page 20\)](#).
- Clean the chain saw components, inspect them for excessive wear or damage, and replace them as needed; refer to [Servicing the Guide Bar, Chain, and Drive Sprocket \(page 21\)](#).
- Check the chain for sharpness and damage, and sharpen or replace as needed; refer to [Sharpening the Chain \(page 22\)](#).
- Check the oil level; refer to [Checking the Oil Level and Adding Bar and Chain Oil \(page 18\)](#).
- Check the chain brake; refer to [Checking the Chain Brake \(page 19\)](#).
- Check the chain saw for damage, general appearance, and performance; ensure that the switches move freely, the vents and handles are clean, and the bar is not bent or damaged.

<b>Rated Voltage</b>	60V DC maximum, 54 VDC nominal usage
<b>Weight (without a battery)</b>	4.35 kg (9.59 lb)
<b>Charger Type</b>	Flex-Force 60V lithium-ion chargers
<b>Battery Type</b>	Flex-Force 60V lithium-ion batteries

### Appropriate Temperature Ranges

Charge/store the battery pack at	5°C (41°F) to 40°C (104°F)*
Use the battery pack at	-30°C (-22°F) to 49°C (120°F)*
Use the tool at	0°C (32°F) to 49°C (120°F)*

\*Charging time will increase if you do not charge the battery within this range.

Store the tool, battery pack, and battery charger in an enclosed clean, dry area.

### Attachments/Accessories

A selection of Toro approved attachments and accessories is available for use with the machine to enhance and expand its capabilities. Contact your Authorized Service Dealer or authorized Toro distributor or go to [www.Toro.com](http://www.Toro.com) for a list of all approved attachments and accessories.

To ensure optimum performance and continued safety certification of the machine, use only genuine Toro replacement parts and accessories. Replacement parts and accessories made by other manufacturers could be dangerous.

# Starting the Chain Saw

1. Ensure that the vents on the chain saw are free from dust and debris (Figure 6).

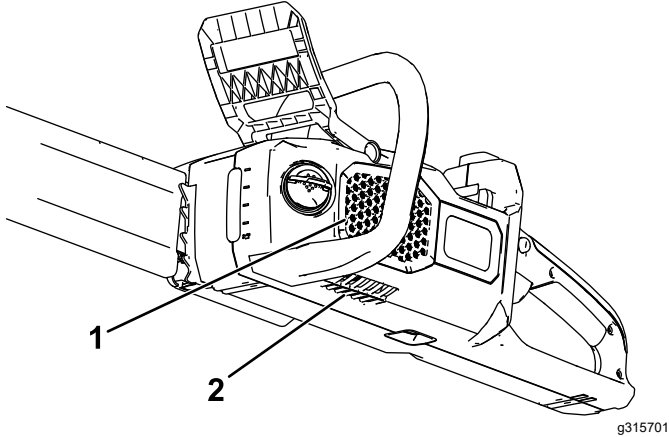

**Figure 6**

1. Side vent
2. Bottom vent

2. Set the chain saw down on a level surface.
3. Align the tongue of the battery pack with the battery cavity in the chain saw (Figure 7).

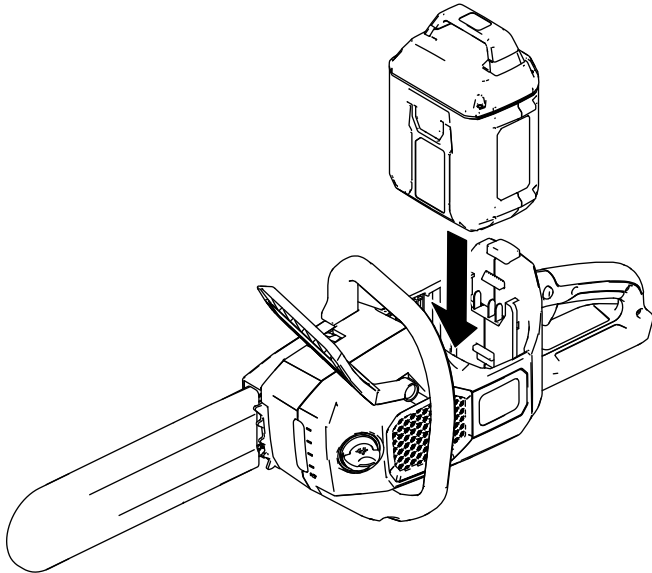

**Figure 7**

4. Push the battery pack into the battery cavity until the battery pack locks into place.
5. Remove the protective cover from the chain.
6. Ensure that the chain brake is in the OPERATING position (Figure 8).

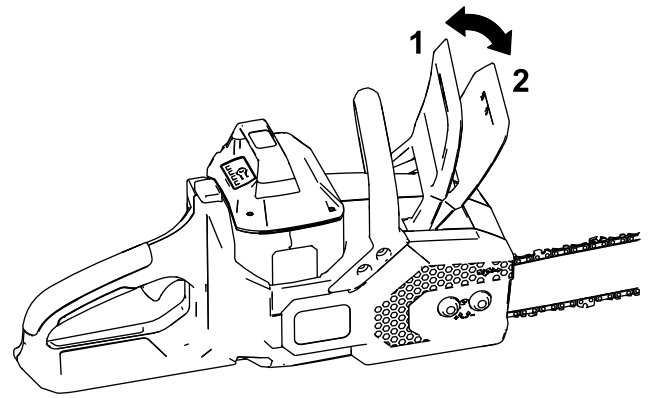

**Figure 8**

1. Chain brake (OPERATING position)
2. Chain brake (STOP position)

7. With your left hand on the front handle and your right hand on the rear handle, press the trigger lock, then squeeze the trigger (Figure 9).

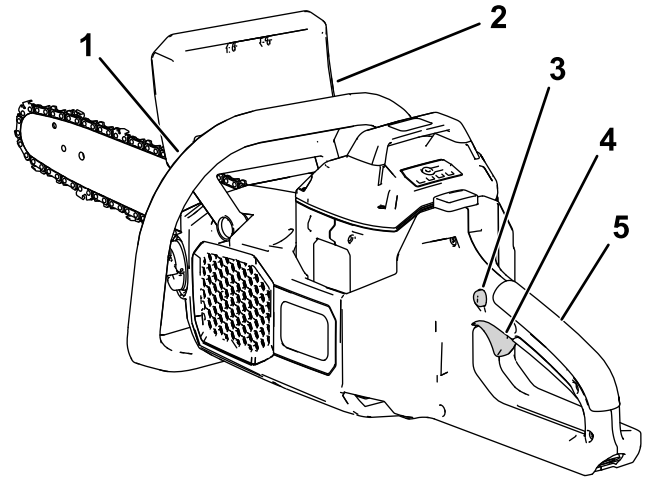

**Figure 9**

1. Front handle
2. Chain brake
3. Trigger lock
4. Trigger
5. Rear handle

# Shutting Off the Chain Saw

To shut off the chain saw, release the trigger.

Whenever you are not using the saw or are transporting the saw to or from the work area, move the chain brake to the STOP position (Figure 8) and remove the battery pack.

# Cutting with the Chain Saw

## ⚠ WARNING

Operating a chain saw improperly can cause serious personal injury or death.

Read and follow all operating instructions carefully to avoid possible personal injury.

## ⚠ WARNING

Kickback can cause serious or fatal injury to you.

Always ensure that the chain brake system is working properly before you operate the chain saw.

Avoid touching objects to be cut with the nose of the chain saw guide bar.

There are 2 types of kickback:

- A fast **upward** motion of the chain saw that results when the chain at the nose or top of the bar contacts an object
- A fast **backward** motion of the chain saw that results when the chain at the nose or top of the bar is pinched by the object being cut

Figure 10 shows the area of the bar to avoid contacting an object to prevent kickback.

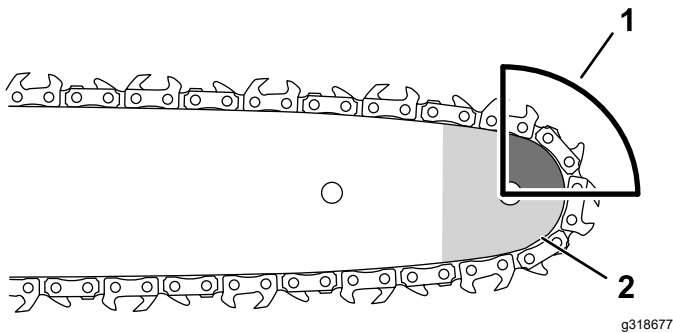

Figure 10

1. Kickback area (nose, top of the bar)
2. Nose

1. Grip the chain saw with 2 hands, with your left hand on the front handle and your right hand on the rear handle as shown in Figure 11.

**Important:** Keep your left arm straight with your elbow locked to help reduce kickback.

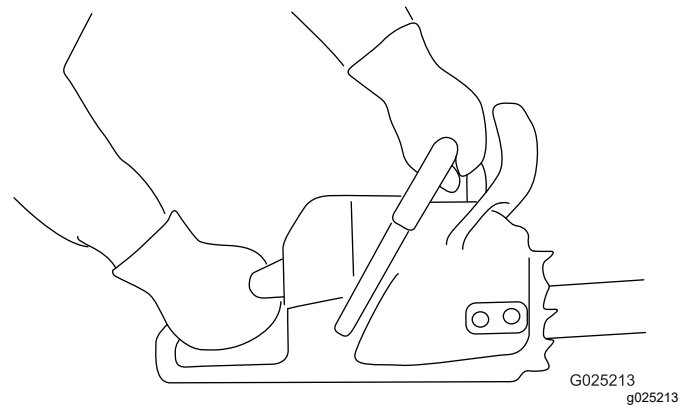

Figure 11

2. Stand on solid, even ground in front of the wood to be cut.
3. Stand to the **left side** of the chain saw, **not in line with the chain**, and position yourself for balanced, stable footing while cutting.

**Important:** Do not stand on the wood that you are cutting.

4. Ensure that you only cut the wood that you intend to cut; do not allow the saw chain to contact the earth, other logs, or any other objects when cutting.
5. Ensure that the saw chain is rotating at full speed before starting a cut.
6. Cut with the wood near the rear of the guide bar, close to the bucking teeth; press the chain saw lightly against the wood and allow the weight of the chain saw to drive the cutting.

**Note:** You can use the bucking teeth (Figure 12) to apply light pressure.

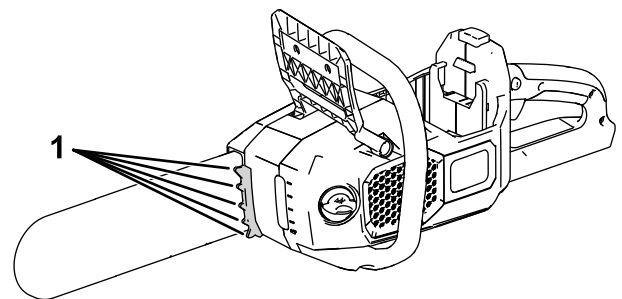

Figure 12

1. Bucking teeth

7. Keep steady pressure on the chain saw, cutting in a straight line, and release pressure only near the end of the cut.

# Pruning a Tree

## ⚠ WARNING

Cutting higher limbs from a tree off the ground can put you in an unstable position that could be unsafe for you while handling a chain saw, resulting in possible serious personal injury or death to you or bystanders.

When cutting limbs from a standing tree, use the following practices:

- Do not climb on limbs or branches with a chain saw.
- Do not overreach, and cut with both hands on the chain saw.
- Ensure that all bystanders are away from the area where branches may fall.

1. Grip the chain saw as shown in [Figure 11](#).
2. While cutting small branches, apply light pressure to the branch to be cut.
3. While cutting larger branches, make a shallow undercut and then complete the cut from the topside of the branch.
  - A. Cut from the underside of the limb about 15 cm (6 inches) from the trunk. Cut a third of the way through the limb.
  - B. Cut 5.0 to 10.0 cm (2 to 4 inches) farther out on the limb and from above. Cut the limb until it falls.
  - C. Cut the limb stub at the branch collar ([Figure 13](#)).

**Important:** Do not cut the limb past the collar, flush to the trunk, or leave a large limb stub; this damages the tree.

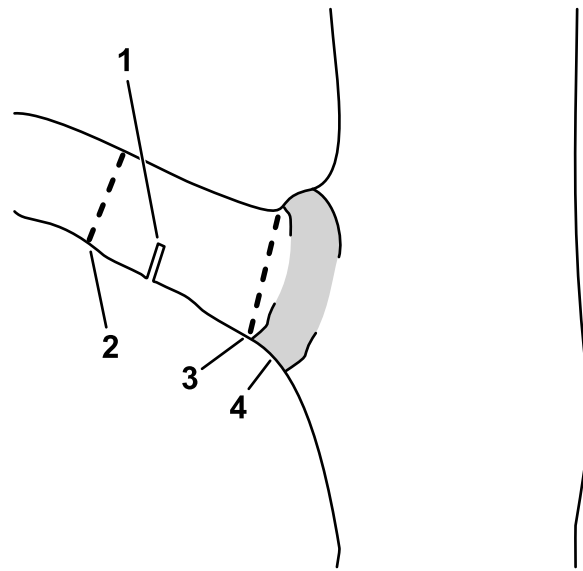

Figure 13

1. First relief undercut
2. Second through cut
3. Final pruning cut to remove the limb stub
4. Branch collar (where the trunk transitions to the limb)

# Felling a Tree

## ⚠ WARNING

Cutting standing trees requires expertise and poses hazards.

- Before attempting to cut a big tree, practice cutting a few branches, limbs, or small logs to familiarize yourself with the chain saw.
- Do not use this chain saw to fell large trees with a diameter larger than the length of the guide bar.

## ⚠ DANGER

Loose or tangled limbs above you may be dislodged by vibration from cutting, causing severe injury or death.

Always look overhead for loose and tangled limbs before cutting; if you see any loose limbs or branches, remove them before cutting.

The proper operator stance for felling a tree is shown in [Figure 14](#).

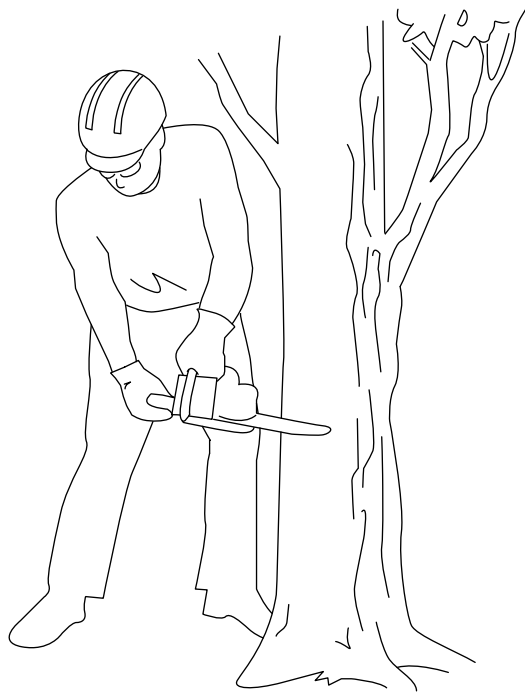

Figure 14

g195831

**Note:** Making this cut prevents the chain saw from being pinched while making the next cut.

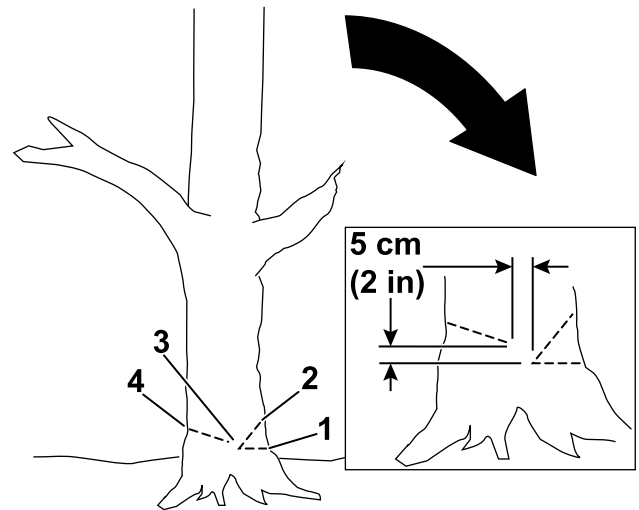

Figure 16

g228707

1. Determine the direction that the tree will fall. Take the following variables into consideration:
  - Wind direction
  - Heavier limbs on 1 side of the tree
  - Natural tilt of the tree (if any)
2. Determine a clear, safe retreat path away from the danger area; refer to Figure 15.

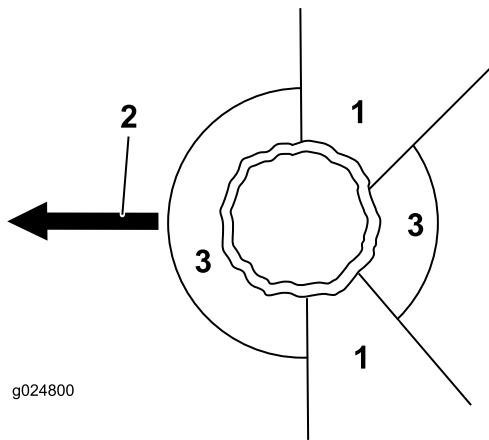

Figure 15

g024800

g024800

1. Retreat path (at a 45° angle opposite from the planned direction of fall)
2. Planned direction of fall
3. Danger area

3. Grip the chain saw as shown in (Figure 11).
4. Make the first cut a third of the way through the tree diameter on the side where you want the tree to fall (Figure 16).

1. First cut
2. Second cut
3. Hinge
4. Back cut

5. Make a second cut to form a notch, starting the cut at least 5 cm (2 inches) above and away from the first cut (Figure 16).

**Important:** Ensure that the first cut and the second cut meet at the same point, forming a clean notch.

6. Make the back cut from the opposite side of the notch and about 5 cm (2 inches) higher than the bottom of the notch as shown in Figure 16.

**Important:** Stop the third cut 2.5 to 5.0 cm (1 to 2 inches) from the notch to form a hinge between the cuts (Figure 16), which keeps the tree from falling in the wrong direction or twisting as it falls.

**Note:** As the back cut nears the hinge (Figure 16), the tree should begin to fall.

7. When the tree begins to fall, remove the chain saw, shut it off, put it down, and retreat along the path you determined in step 2.

**Important:** If the tree begins to fall in an undesired direction, immediately stop the cut, shut off the chain saw, put the chain saw down, and use a non-metallic wedge to open the back cut and push the tree in the desired direction.

# Limbing a Fallen Tree

1. Grip the chain saw as shown in [Figure 11](#).
2. Moving from the base of the tree up, cut off the smaller limbs from the tree that are not supporting its weight off the ground ([Figure 17](#)).
3. Cut the larger limbs that support the weight of the tree from the bottom upward so that the limbs do not pinch the saw blade ([Figure 18](#)).

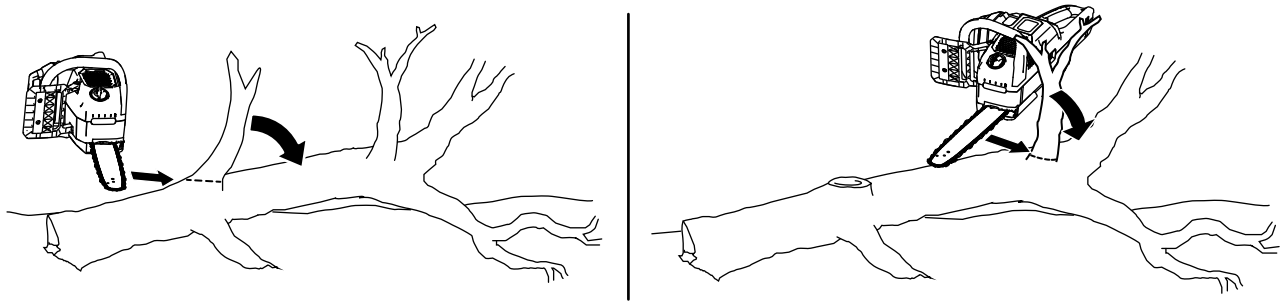

Figure 17

g316601

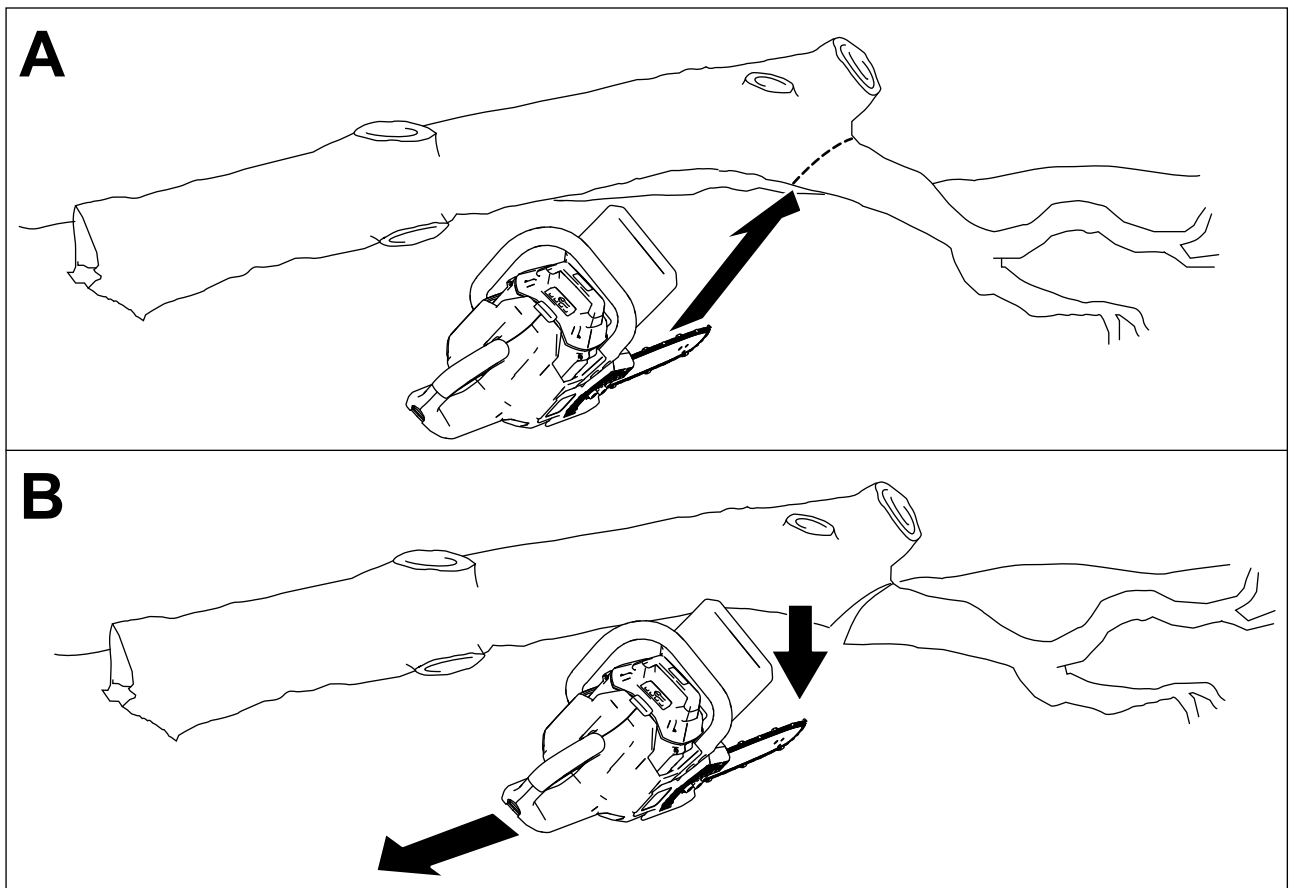

Figure 18

g315751

# Bucking a Log

When bucking a log, note where the log is supported and where there is a load on the log. Cut the log so that when the ends fall, your guide bar will not be pinched between them.

**Important:** If the chain saw binds in the cut, do not attempt to free it by running the motor. Shut off the saw, remove the battery, then use a wedge to pry open the cut and release the saw.

If you are cutting branches from a fallen tree or cutting a log into lengths, support the log off the ground (preferably on a sawbuck).

- If the log is supported on both ends, but not in the middle, the load is on the center of the log.
  - Start from the top and cut about a third of the way through the log (Figure 19A).
  - Make a second cut from the underside to meet the first cut (Figure 19B). This keeps the log from pinching the saw.

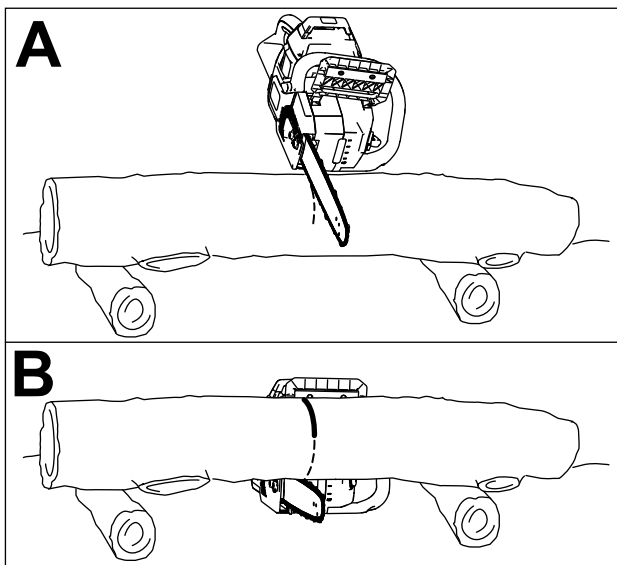

Figure 19

g315765

- If the log is supported on a single end, the load is on the free end of the log.
  - Start from the underside and cut about a third of the way through the log.
  - Make a second cut from the top to meet the first cut. This keeps the log from pinching the saw.
- If the log is supported off the ground along its entire length, without a heavy load on the log at any point, cut all the way through the log from the top.
- If the log is on a hill, always stand on the uphill side of the log (Figure 20).

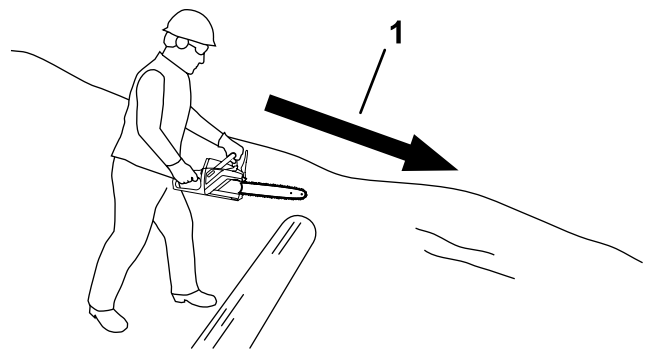

Figure 20

g315767

1. Direction of slope

- If the whole length of the log is supported on flat, level ground, cut a third of the diameter from the top, then roll the log over and make another cut to meet the first cut (Figure 21).

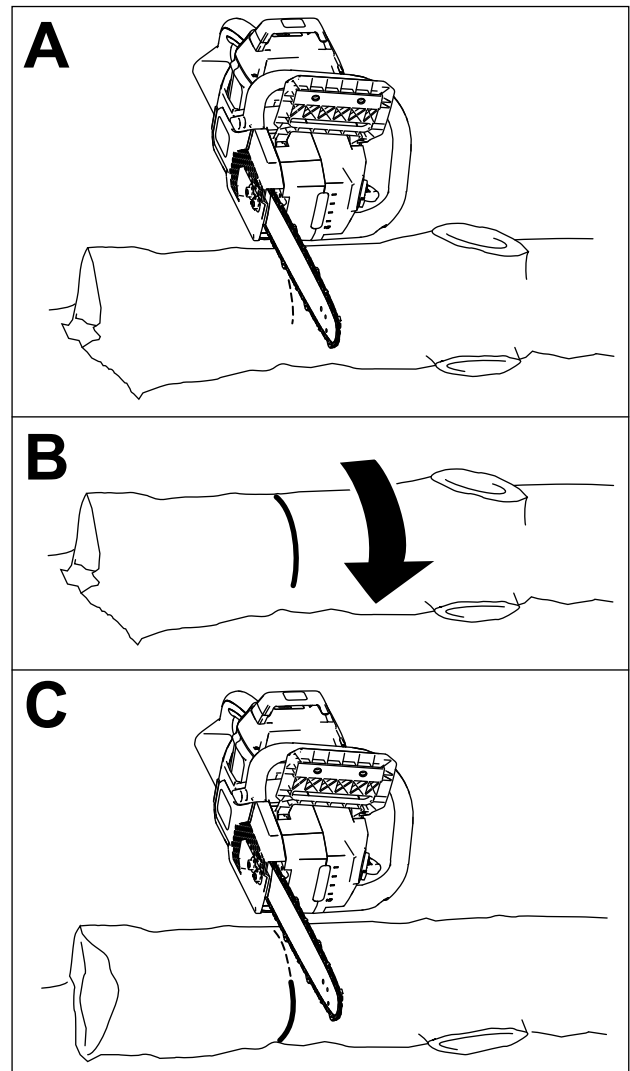
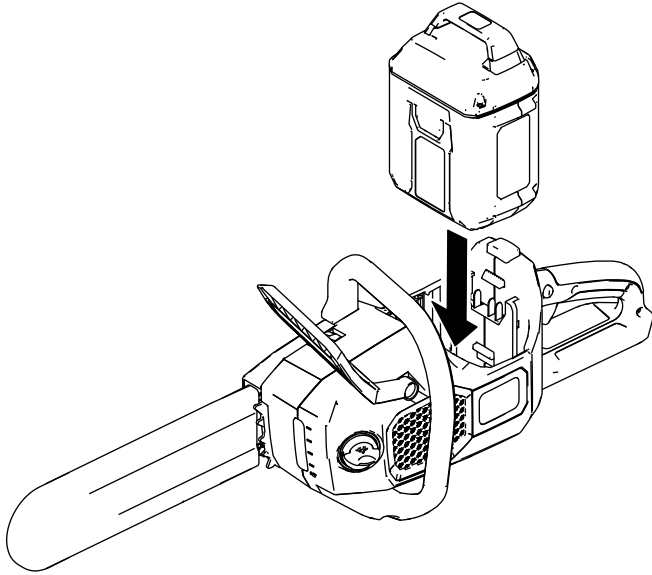

Figure 21

g315766

## Installing the Battery Pack

1. Set the chain saw down on a level surface.
2. Align the tongue of the battery pack with the battery cavity in the chain saw ([Figure 22](#)).

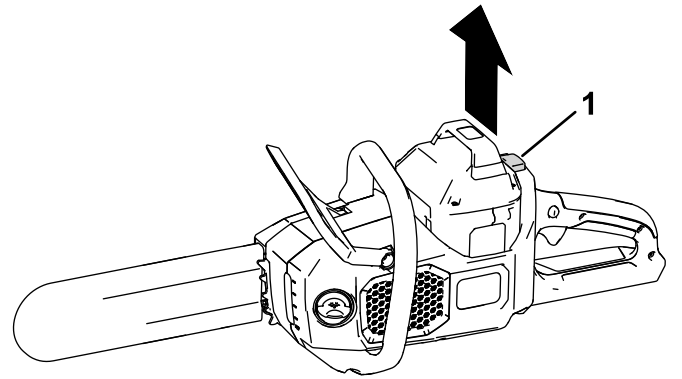

**Figure 22**

g315702

## Removing the Battery Pack

1. Place the chain saw on a flat surface.
2. Press down on the latch and remove the battery pack from the cavity.



**Figure 23**

g315763

1. Latch
- 

3. Push the battery pack into the battery cavity until the battery pack locks into place.

# Maintenance

## Recommended Maintenance Schedule(s)

Maintenance Service Interval	Maintenance Procedure
Before each use or daily	<ul style="list-style-type: none"> <li>• Check the oil level and add bar and chain oil if necessary.</li> <li>• Check the chain brake.</li> <li>• Check that oil is flowing to the chain.</li> <li>• Check the chain tension and adjust it if necessary.</li> <li>• Ensure that the bar is straight and undamaged</li> <li>• Check the chain for sharpness; contact an Authorized Service Dealer to have the chain sharpened or replaced.</li> </ul>
After each battery drain cycle	<ul style="list-style-type: none"> <li>• Check the oil level and add bar and chain oil if necessary.</li> <li>• Check the chain brake.</li> <li>• Check the chain tension and adjust it if necessary.</li> </ul>
Yearly or before storage	<ul style="list-style-type: none"> <li>• Service the guide bar, chain, and drive sprocket.</li> <li>• Check the chain for sharpness; contact an Authorized Service Dealer to have the chain sharpened or replaced.</li> </ul>

## Checking the Oil Level and Adding Bar and Chain Oil

**Service Interval:** Before each use or daily

After each battery drain cycle

**Important:** Use only bar and chain oil (sold separately).

1. Shut off the chain saw and remove the battery pack; refer to [Removing the Battery Pack \(page 17\)](#).
2. Check the oil level in the window. If the oil does not fill the window, add bar and chain oil as needed ([Figure 24](#)).

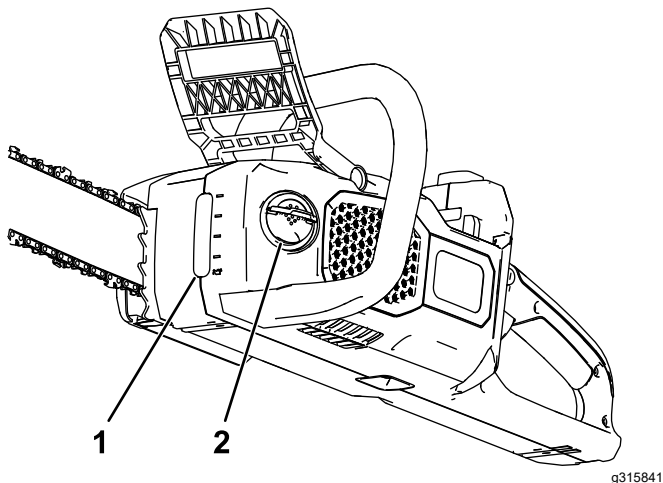

**Figure 24**

1. Oil window

2. Oil cap

3. Place the chain saw on a flat surface with the oil cap facing up.

4. Clean the area around the oil cap ([Figure 24](#)).

**Note:** Ensure that you do not allow debris/wood chips to enter the oil tank.

5. Unfold the wing-nut tab on the oil cap tab, remove the cap, and pour bar and chain oil into the chain saw until the oil fills the tank ([Figure 24](#)).

**Important:** Do not fill the chain saw higher than the bottom of the fill neck.

6. Clean up any spilled oil, secure the oil cap, and fold the wing-nut tab down.

7. Ensure that oil is flowing to the chain; refer to [Checking the Flow of Bar and Chain Oil \(page 19\)](#).

# Checking the Chain Brake

**Service Interval:** Before each use or daily

After each battery drain cycle

1. Engage the chain brake by moving the chain brake forward to the STOP position ([Figure 25](#)).

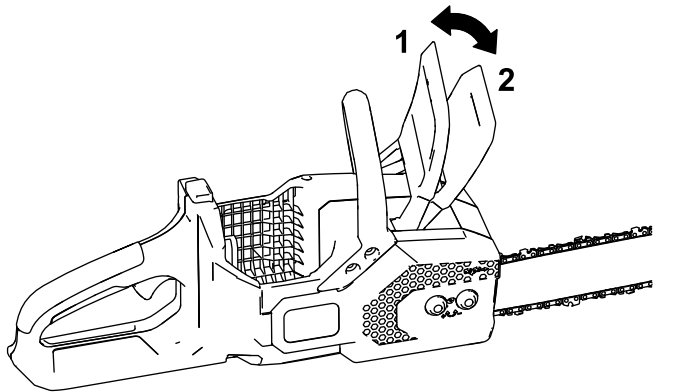

**Figure 25**

g315840

1. Chain brake (OPERATING position)
2. Chain brake (STOP position)

2. Prepare to test the chain saw operation; refer to [Before Using the Chain Saw \(page 10\)](#).
3. Attempt to start the chain saw. If it starts, take the chain saw to an Authorized Service Dealer for repair.
4. Disengage the chain brake by moving the chain brake rearward to the OPERATING position ([Figure 25](#)).

# Checking the Flow of Bar and Chain Oil

**Service Interval:** Before each use or daily

1. Prepare to use the chain saw; refer to [Before Using the Chain Saw \(page 10\)](#).
2. To ensure that oil is flowing to the chain, point the nose of the chain saw a few inches from a surface (e.g. paper, cardboard, a stump) and run the chain saw; you should be able to see a light spray of oil on the surface ([Figure 26](#)).

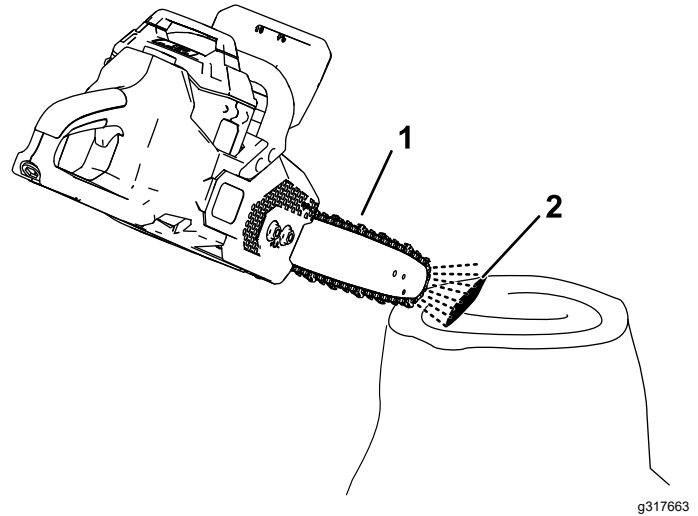

**Figure 26**

g317663

1. Run the chain saw a few inches from a surface.
2. If the oil is flowing, it will spray off the chain and accumulate.

3. If oil is not flowing, ensure that there is oil in the tank and that the area under the side cover is clean; refer to [Checking the Oil Level and Adding Bar and Chain Oil \(page 18\)](#) and [Servicing the Guide Bar, Chain, and Drive Sprocket \(page 21\)](#).

# Adjusting the Chain Tension

**Service Interval:** Before each use or daily  
After each battery drain cycle

Ensure that the chain is properly tensioned.

A loose chain shortens the life of the drive sprocket and the guide bar and may cause the chain to fall off.

An overtightened chain overheats the guide bar and chain, causing rapid wear, and may burn out the motor or break the chain.

The chain tension is correct when you are able to use a gloved hand to pull the chain smoothly around the guide bar. The chain should remain in contact with the bottom edge of the guide bar.

Also, check the chain tension of a new chain after a few cuts; a new chain usually stretches and requires adjustment after a few cuts.

## **⚠ DANGER**

**Contact with the chain saw teeth can cause serious personal injury.**

- **Remove the battery pack before adjusting or maintaining the chain saw.**
- **Always wear gloves when adjusting or maintaining the chain saw.**

1. Place the chain saw on a level surface and remove the battery pack; refer to [Removing the Battery Pack \(page 17\)](#).
2. Allow the saw chain to cool.

**Important:** Do not tension a hot chain; it may contract as it cools, resulting in an overtightened chain.

3. Inspect the guide bar for bends or damage, replace if necessary.
4. Ensure that the chain brake is in the OPERATING position ([Figure 25](#)).
5. Using the onboard multitool, loosen the captive nuts on the side cover, but do not remove it ([Figure 28](#)).

6. Hold up the tip of the guide bar ([Figure 27](#)).

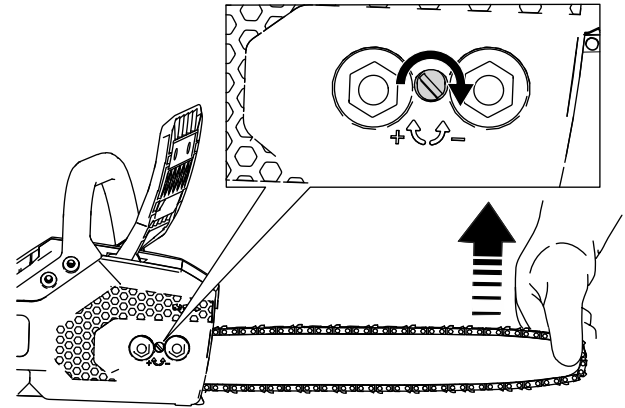

**Figure 27**

g315842

7. Using the onboard multitool, adjust the chain tension, and then secure the side cover to the chain saw by tightening the captive nuts ([Figure 28](#)).

- **To tighten the chain**, turn the chain tensioning screw clockwise ([Figure 27](#)).
- **To loosen the chain**, turn the chain tensioning screw counterclockwise

Adjust the chain tension until the chain touches the bottom edge of the guide bar, then pull the chain away from the bottom edge of the guide bar; a properly adjusted chain can only be pulled 3.2 to 6.4 mm (1/8 to 1/4 inch) away from the guide bar, and snaps back on release.

If the chain is not properly tensioned, loosen the side cover and repeat steps 5 through 7.

8. Use a gloved hand to pull the chain around the guide bar. A properly tensioned chain should move smoothly and remain in contact with the bottom edge of the guide bar.
9. Check the chain tension again and repeat this procedure if necessary.

# Servicing the Guide Bar, Chain, and Drive Sprocket

Yearly or before storage

## **⚠ DANGER**

Contact with the chain saw teeth can cause serious personal injury.

- Remove the battery pack before adjusting or maintaining the chain saw.
- Always wear gloves when adjusting or maintaining the chain saw.

1. Place the chain saw on a flat surface and remove the battery pack; refer to [Removing the Battery Pack \(page 17\)](#).
2. Remove the side cover by loosening the 2 captive nuts that secure the cover ([Figure 28](#)).

**Note:** The captive nuts do not separate from the side cover; loosen them until the cover can be removed.

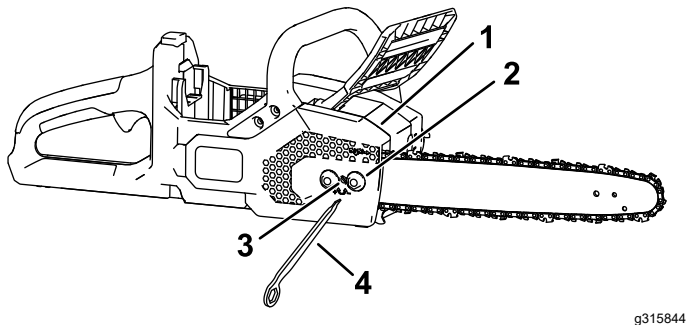

**Figure 28**

- |                |                           |
|----------------|---------------------------|
| 1. Cover       | 3. Chain tensioning screw |
| 2. Captive nut | 4. Multitool              |

3. Loosen the chain by turning the chain-tightening screw counterclockwise ([Figure 28](#)).
4. Separate the chain from the guide bar and set them aside.
5. Remove the clip and drive sprocket from the chain saw ([Figure 29](#)).
6. Clean any debris from the area under the side cover.
7. Inspect the drive sprocket; if it is excessively worn or damaged, replace it.
8. Install the drive sprocket and clip.
9. Check the oil outlet ([Figure 29](#)) for debris and clean the area if necessary.

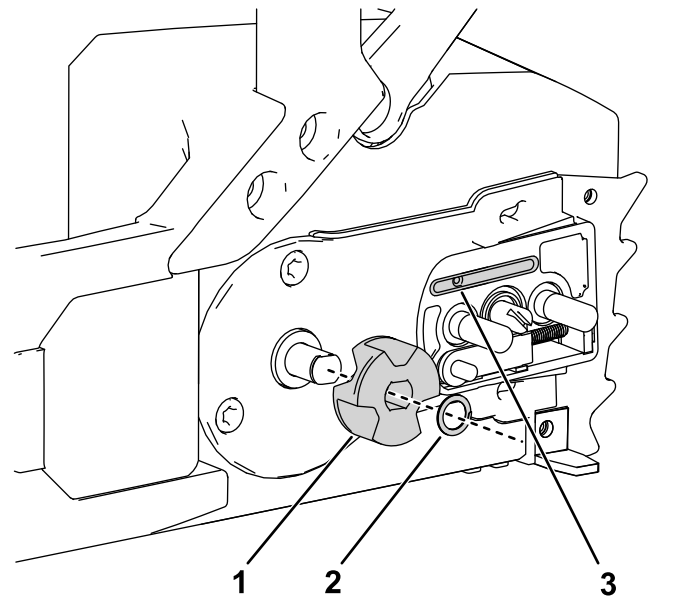
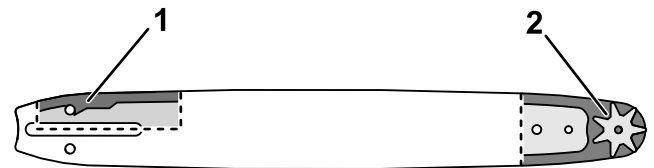

**Figure 29**

- |                   |               |
|-------------------|---------------|
| 1. Drive sprocket | 3. Oil outlet |
| 2. Clip           |               |

10. Clean the guide bar and chain; use a wire or a small flat-head screwdriver to remove dirt and debris from the groove along the edge of the guide bar, starting from the sprocket on the front end and moving rearward.

Ensure that the oil channel in the bar that aligns with the oil outlet on the chain saw is clean so that oil can flow freely to the chain ([Figure 30](#)).



**Figure 30**

Internal sections of the guide bar shown

- |  |  |
|--|--|
| 1. Ensure that this channel connecting to the oil outlet is clean. | 2. Ensure that the bar sprocket is clean and rotates freely. |
|--|--|
11. Inspect the guide bar and chain; if the bar is bent, the grooves are damaged, or if the sprocket on the front end does not rotate freely, replace the guide bar; if the chain is excessively worn or damaged, replace it.
  12. Install the guide bar and chain; refer to [Installing the Guide Bar and Chain \(page 22\)](#).
  13. Ensure that oil is flowing to the chain; refer to [Checking the Flow of Bar and Chain Oil \(page 19\)](#).

# Installing the Guide Bar and Chain

## **⚠ DANGER**

Contact with the chain saw teeth can cause serious personal injury.

- Remove the battery pack before adjusting or maintaining the chain saw.
  - Always wear gloves when adjusting or maintaining the chain saw.
1. If the side cover is installed to the machine, loosen the 2 captive nuts securing the side cover to the machine and remove it (Figure 31A and Figure 31B).
  2. Place the chain around the drive sprocket on the front end of the guide bar, **with the cutting edge of the chain teeth on the top of the bar facing forward** as shown in the diagram on the side cover of the chain saw (Figure 31C).

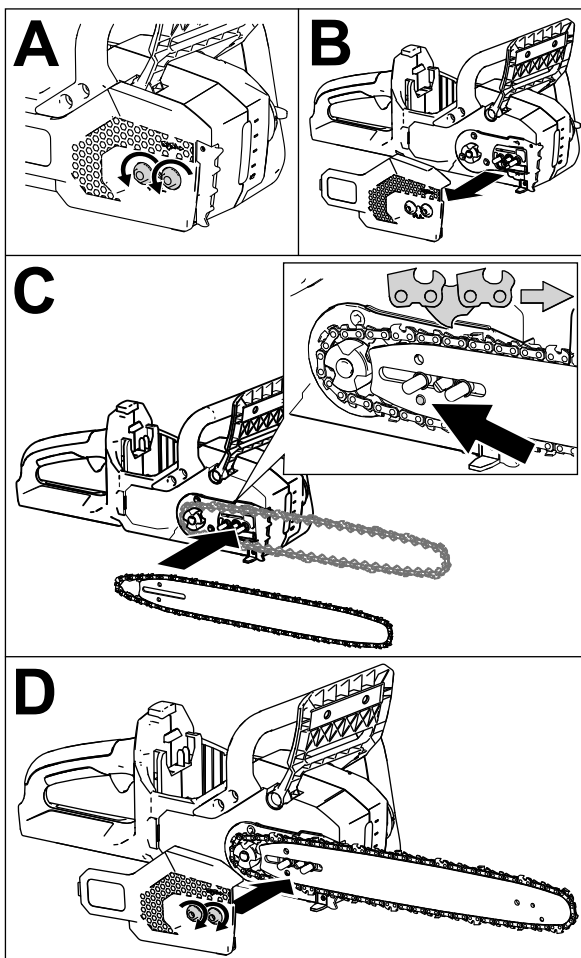

Figure 31

g315857

3. Feed the chain around the guide bar and align the chain teeth into the groove of the bar.
4. Position the open loop of the chain (not on the guide bar) around the drive sprocket on the chain saw and install the guide bar and attached chain onto the chain saw as shown in Figure 31C.

**Important:** Ensure that the chain adjusting stud is inserted into the hole indicated by the arrow in Figure 31C. You may need to rotate the chain tensioning knob to fit the stud into the hole in the guide bar.

5. Install the side cover, but do not fully tighten the captive nuts (Figure 31D).
6. Adjust the chain tension; refer to [Adjusting the Chain Tension](#) (page 20).

## Sharpening the Chain

Yearly or before storage

A sharp chain ensures better cutting performance and longer battery life.

The chain needs to be sharpened or replaced if you must force it onto the wood, or if it produces sawdust instead of full wood chips.

Contact an Authorized Service Dealer to have the chain sharpened or replaced.

## Service

Should the chain saw need service, take the tool to your Authorized Service Dealer.

# Storage

**Important:** Store the machine, battery pack, and charger only in temperatures that are within the appropriate range; refer to [Specifications \(page 9\)](#).

**Important:** If you are storing the battery pack for the off-season, charge it until 1 or 2 LED indicators turn green on the battery. Do not store a fully charged or fully depleted battery. When you are ready to use the machine again, charge the battery pack until the left indicator light turns green on the charger or all 4 LED indicators turn green on the battery.

- Disconnect the machine from the power supply (i.e., remove the battery pack) and check for damage after use.
- Clean all foreign material from the machine.
- Do not store the machine with the battery pack installed.
- Store the machine, battery pack, and battery charger in a well-ventilated place that is inaccessible to children.
- Keep the machine, battery pack, and battery charger away from corrosive agents such as garden chemicals and de-icing salts.
- To reduce the risk of serious personal injury, do not store the battery pack outside or in vehicles.
- Store the machine, battery pack, and battery charger in an enclosed clean, dry area.

# Preparing the Battery Pack for Recycling

**Important:** Upon removal, cover the terminals of the battery pack with heavy-duty adhesive tape. Do not attempt to destroy or disassemble the battery pack or remove any of its components.



Contact your local municipality or your authorized Authorized Service Dealer or distributor for more information on how to responsibly recycle the battery.

	Lithium-ion battery packs labeled with the Call2Recycle seal can be recycled at any participating retailer or battery recycling facility in the Call2Recycle program (US and Canada only). To locate a participating retailer or facility closest to you, please call 1-800-822-8837 or visit <a href="http://www.call2recycle.org">www.call2recycle.org</a> .
	Lithium-ion battery packs labeled with the High Energy Battery (HEB) seal shown here, and any 60V Flex-Force batteries 6.0 Ah or greater, can be recycled at any participating dealer or retailer in the Call2Recycle HEB program. To locate a participating dealer or retailer closest to you, please visit <a href="http://www.hebattery.org">www.hebattery.org</a> .

If you cannot locate a participating retailer or facility nearby, or have questions about which recycling program your battery pack may qualify for, please visit the customer support site listed in the operator's manual for your tool/equipment for more information on how to responsibly recycle the battery pack.

If you are located outside of the US and Canada, please contact your Authorized Service Dealer or distributor for more information on how to responsibly recycle the battery pack.

# Troubleshooting

Perform only the steps described in these instructions. All further inspection, maintenance, and repair work must be performed by an authorized service center or a similarly qualified specialist if you cannot solve the problem yourself.

Always remove the battery from the tool when troubleshooting, inspecting, maintaining, or cleaning the tool.

Problem	Possible Cause	Corrective Action
The chain saw does not run or does not run continuously.	<ol style="list-style-type: none"> <li>1. The battery pack is low on charge.</li> <li>2. The battery pack is not fully seated.</li> <li>3. The battery pack is over or under the appropriate temperature range.</li> <li>4. The battery pack has exceeded high amperage limits.</li> <li>5. There is moisture on the leads of the battery pack.</li> <li>6. The chain brake is engaged.</li> <li>7. There is debris under the cover.</li> </ol>	<ol style="list-style-type: none"> <li>1. Charge the battery pack.</li> <li>2. Ensure that the battery pack is inserted all the way into the housing.</li> <li>3. Move the battery pack to a place where it is dry and the temperature is between 5°C (41°F) and 40°C (104°F).</li> <li>4. Release the trigger, then press the trigger switch.</li> <li>5. Allow the battery pack to dry or wipe it dry.</li> <li>6. Disengage the chain brake by moving the chain brake rearward.</li> <li>7. Remove the cover and clean out any debris.</li> </ol>
The chain saw runs, but the chain does not rotate.	<ol style="list-style-type: none"> <li>1. The chain is not properly seated on the drive sprocket.</li> <li>2. There is debris under the cover.</li> </ol>	<ol style="list-style-type: none"> <li>1. Install the chain and ensure that the links are properly seated in the drive sprocket.</li> <li>2. Remove the cover and clean out any debris.</li> </ol>
The chain brake does not engage.	<ol style="list-style-type: none"> <li>1. The chain brake is damaged.</li> </ol>	<ol style="list-style-type: none"> <li>1. Immediately take the chain saw to a Authorized Service Dealer.</li> </ol>
The chain saw does not properly cut.	<ol style="list-style-type: none"> <li>1. The chain is not tensioned correctly.</li> <li>2. The chain is dull or damaged.</li> <li>3. The guide bar is bent or the grooves are damaged.</li> <li>4. The chain is installed backward.</li> <li>5. The chain is not being lubricated properly.</li> </ol>	<ol style="list-style-type: none"> <li>1. Set the proper tension on the chain.</li> <li>2. Replace the chain.</li> <li>3. Replace the guide bar</li> <li>4. Install the chain correctly.</li> <li>5. Check the oil level and ensure that oil is flowing to the chain.</li> </ol>
The chain oil is not lubricating properly.	<ol style="list-style-type: none"> <li>1. The oil level is low.</li> <li>2. The oil outlet is plugged.</li> <li>3. There is debris under the cover.</li> <li>4. The oil channel or groove in the guide bar is plugged.</li> </ol>	<ol style="list-style-type: none"> <li>1. Check the oil level.</li> <li>2. Clean out debris from the oil outlet.</li> <li>3. Remove the cover and clean out any debris.</li> <li>4. Clean out debris in the bar.</li> </ol>
The battery pack loses charge quickly.	<ol style="list-style-type: none"> <li>1. The battery pack is over or under the appropriate temperature range.</li> <li>2. The chain is dull or damaged.</li> <li>3. The guide bar is bent or the grooves are damaged.</li> <li>4. The machine is overloaded.</li> <li>5. The chain is not being lubricated properly.</li> </ol>	<ol style="list-style-type: none"> <li>1. Move the battery pack to a place where it is dry and the temperature is between 5°C (41°F) and 40°C (104°F).</li> <li>2. Replace the chain.</li> <li>3. Replace the guide bar</li> <li>4. Apply less pressure when cutting.</li> <li>5. Check the oil level and ensure that oil is flowing to the chain.</li> </ol>