

TORO[®]

Count on it.

Operator's Manual

**Flex-Force Power System[®]
60V MAX Power Head**

Model No. 51810T—Serial No. 326000000 and Up

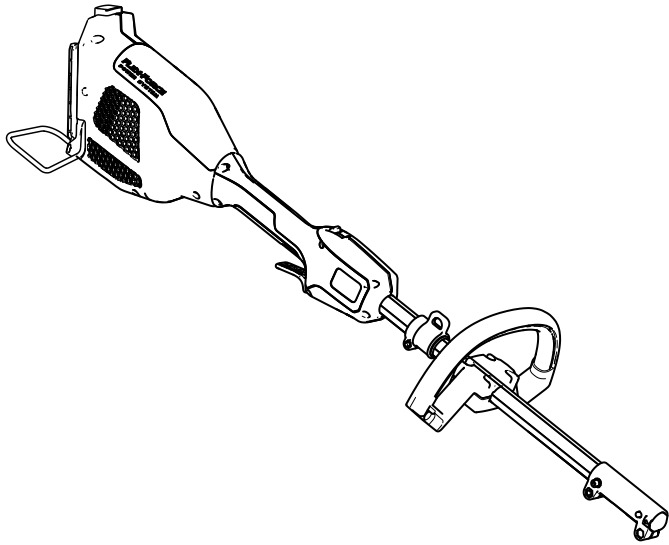



For assistance, please see www.Toro.com/support for instructional resources or contact your Authorized Service Dealer before returning this product.

⚠ WARNING

CALIFORNIA Proposition 65 Warning

Use of this product may cause exposure to chemicals known to the State of California to cause cancer, birth defects, or other reproductive harm.

Introduction

This power head is intended to be used by residential homeowners to power attachment tools. It is designed to be used only in combination with Flex-Force™ 60V Max attachments. It is designed to use Flex-Force 60V lithium-ion battery packs. These battery packs are designed to be charged only by Flex-Force 60V lithium-ion battery chargers. Using this product for purposes other than its intended use could prove dangerous to you and bystanders.

Read this information carefully to learn how to operate and maintain your product properly and to avoid injury and product damage. You are responsible for operating the product properly and safely.

Visit www.Toro.com for product safety and operation training materials, accessory information, help finding a dealer, or to register your product.

Model 51810T does not include a battery or a charger.



Whenever you need service, genuine the manufacturer parts, or additional information, contact an Authorized Service Dealer or the manufacturer Customer Service and have the model and serial numbers of your product ready. [Figure 1](#) identifies the location of the model and serial numbers on the product. Write the numbers in the space provided.

Important: With your mobile device, you can scan the QR code on the serial number decal (if equipped) to access warranty, parts, and other product information.

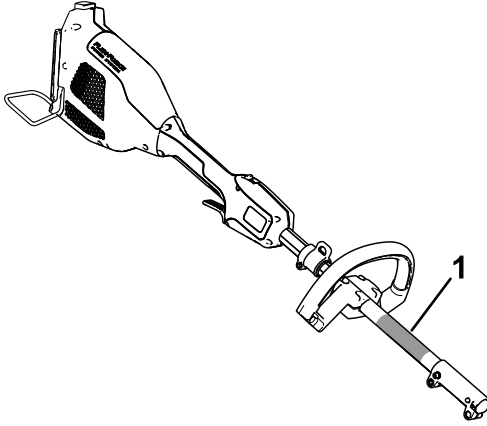

Figure 1

g372328

1. Model and serial number location

<p>Model No. _____</p> <p>Serial No. _____</p>
--

Safety-Alert Symbol

The safety-alert symbol (Figure 2) shown in this manual and on the machine identifies important safety messages that you must follow to prevent accidents.



Figure 2
Safety-alert symbol

g000502

The safety-alert symbol appears above information that alerts you to unsafe actions or situations and is followed by the word **DANGER**, **WARNING**, or **CAUTION**.

DANGER indicates an imminently hazardous situation which, if not avoided, **will** result in death or serious injury.

WARNING indicates a potentially hazardous situation which, if not avoided, **could** result in death or serious injury.

CAUTION indicates a potentially hazardous situation which, if not avoided, **may** result in minor or moderate injury.

This manual uses two other words to highlight information. **Important** calls attention to special mechanical information and **Note** emphasizes general information worthy of special attention.

The Model 51810T Power Head is compatible with a variety of Toro-approved attachments that, when combined, comply with specific standards; see the following table for more detail.

Combination	Power Head Model	Attachment Model	Standard
String Trimmer	51810T	88716	Conforms to UL STD 82 Certified to CSA STD C22.2 No. 147
Edger	51810T	88710	Conforms to UL STD 82 Certified to CSA STD C22.2 No. 147
Pole Saw	51810T	88714	Conforms to UL STD 82 Certified to CSA STD C22.2 No. 147
Cultivator	51810T	88715	Conforms to UL STD 82 Certified to CSA STD C22.2 No. 147
Hedge Trimmer	51810T	88713	Conforms to UL STD 62841-4-2 Certified to CSA STD C22.2 62841-4-2

Safety

IMPORTANT SAFETY INSTRUCTIONS

⚠ WARNING

When using electric gardening appliances, always read and follow basic safety warnings and instructions to reduce the risk of fire, electric shock, and personal injury, including the following:

In addition to these instructions, always read and follow the safety warnings and instructions included with your specific attachment before operating the power head.

Read All Instructions

I. Training

1. The operator of the appliance is responsible for any accidents or hazards occurring to others or their property.
2. Do not allow children to use or play with the appliance, battery pack, or the battery charger; local regulations may restrict the age of the operator.
3. Do not allow children or untrained people to operate or service this device. Allow only people who are responsible, trained, familiar with the instructions, and physically capable to operate or service the device.
4. Before using the appliance, battery pack, and battery charger, read all the instructions and cautionary markings on these products.
5. Become familiar with the controls and proper use of the appliance, battery pack, and battery charger.

II. Preparation

1. Keep bystanders and children away from the operating area.
2. Use only the battery pack specified by Toro. Using other accessories and attachments may increase the risk of injury and fire.
3. Plugging the battery charger into an outlet that is not 120 V can cause a fire or electric shock. Do not plug the battery charger into an outlet other than 120 V. For a different style of connection, use an attachment plug adapter of the proper configuration for the power outlet if needed.
4. Do not use a damaged or modified battery pack or battery charger, which may exhibit unpredictable behavior that results in fire, explosion, or risk of injury.
5. If the supply cord to the battery charger is damaged, contact an Authorized Service Dealer to replace it.
6. Charge the battery pack with only the battery charger specified by Toro. A charger suitable for 1 type of battery pack may create a risk of fire when used with another battery pack.
7. Charge the battery pack in a well-ventilated area only.
8. Follow all charging instructions and do not charge the battery pack outside of the temperature range specified in the instructions. Otherwise, you may damage the battery pack and increase the risk of fire.
9. Do not operate the appliance without all guards and other safety protective devices in place and functioning properly on the appliance.
10. Refer to your attachment Operator's Manual for additional PPE specific to your attachment.

III. Operation

1. Do not operate the power head without an attachment installed.
2. Avoid dangerous environments—Do not use the appliance in rain or in damp or wet locations.
3. Use the proper appliance for your application—Using the appliance for purposes other than its intended use could prove dangerous to you and bystanders.
4. Prevent unintentional starting—Ensure that the switch is in the OFF position before connecting to the battery pack and handling the appliance. Do not carry the appliance with your finger on the switch or energize the appliance with the switch in the ON position.
5. Operate the appliance only in daylight or good artificial light.
6. Remove the battery pack from the appliance before adjusting it or changing accessories.
7. Keep your hands and feet away from the cutting area and all moving parts.
8. Stop the appliance, remove the battery pack from the appliance, and wait for all movement to stop before adjusting, servicing, cleaning, or storing the appliance.
9. Remove the battery pack from the appliance whenever you leave it unattended.
10. Do not force the appliance—Allow the appliance to do the job better and safer at the rate for which it was designed.
11. Do not overreach—Keep proper footing and balance at all times, especially on slopes. Walk, never run with the appliance.
12. Stay alert—Watch what you are doing and use common sense when operating the appliance. Do not use the appliance while ill, tired, or under the influence of alcohol or drugs.
13. Ensure that the ventilation openings are kept clear of debris.
14. Under abusive conditions, the battery pack may eject liquid; avoid contact. If you accidentally come into contact with the liquid, flush with water. If the liquid contacts your eyes, seek medical help. Liquid ejected from the battery pack may cause irritation or burns.
15. Do not expose a battery pack or tool to fire or excessive temperature. Exposure to fire or temperature above 130°C (265°F) may cause explosion.
16. CAUTION—A mistreated battery pack may present a risk of fire, explosion, or chemical burn.

- Do not disassemble the battery pack.
- Replace the battery pack with a genuine Toro battery pack only; using another type of battery pack may cause a fire or risk of injury.
- Keep battery packs out of the reach of children and in the original packaging until you are ready to use them.

IV. Maintenance and Storage

1. Maintain the appliance with care—Keep it clean and in good repair for best performance and to reduce the risk of injury. Follow the instructions for lubricating and changing accessories. Keep handles dry, clean, and free from oil and grease.
2. When the battery pack is not in use, keep it away from metal objects such as paper clips, coins, keys, nails, and screws that can make a connection from 1 terminal to another. Shorting the battery terminals may cause burns or a fire.
3. Keep your hands and feet away from moving parts.
4. Stop the appliance, remove the battery pack from the appliance, and wait for all movement to stop before adjusting, servicing, cleaning, or storing the appliance.
5. Check the appliance for damaged parts—If there are damaged guards or other parts, determine whether it will operate properly. Check for misaligned and binding moving parts, broken parts, mounting, and any other condition that may affect its operation. Unless indicated in the instructions, have an Authorized Service Dealer repair or replace a damaged guard or part.
6. Do not replace the existing non-metallic cutting means on the appliance with a metallic cutting means.
7. Do not attempt to service or repair the appliance, battery pack, or battery charger except as indicated in the instructions. Have an Authorized Service Dealer perform service using identical replacement parts to ensure that the product is safely maintained.
8. Store an idle appliance indoors in a place that is dry, secure, and out of the reach of children.
9. Do not dispose of the battery in a fire. The cell may explode. Check with local codes for possible special disposal instructions.

SAVE THESE INSTRUCTIONS

Setup

1

Installing the Auxiliary Handle

Parts needed for this procedure:

1	Auxiliary handle assembly
---	---------------------------

Procedure

1. Separate the auxiliary handle from the handle plate by removing the 4 socket head screws using the provided Allen wrench (A of [Figure 3](#)).
2. Line up the auxiliary handle with auxiliary handle plate on the trimmer handle (B of [Figure 3](#)).
3. Secure the auxiliary handle to the handle plate with the 4 socket head screws previously removed (C of [Figure 3](#)).

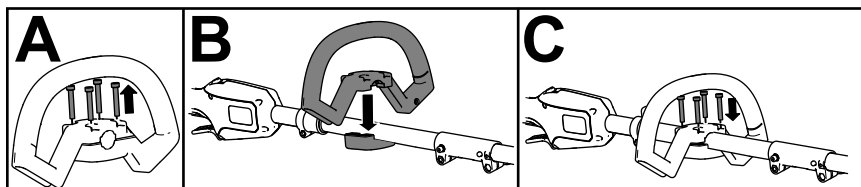

Figure 3

g529124

2

Connecting the Attachment to the Power Head

No Parts Required

Procedure

To connect your attachment to the power head, refer to the *Operator's Manual* for your attachment.

3

Installing the Battery Guard Rod

Parts needed for this procedure:

1	Battery guard rod
---	-------------------

Procedure

1. Align the arms of the guard rod with the guide on the power head.
2. Lightly pull the arms of the guard rod so that they fit around the power head, and fit the rod ends into the mounting holes.

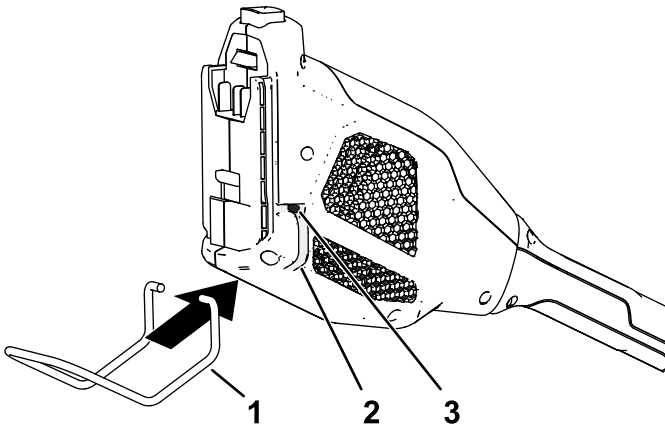

g385364

Figure 4

- 1. Battery guard rod
 - 2. Rod guide
 - 3. Mounting hole
-

Product Overview

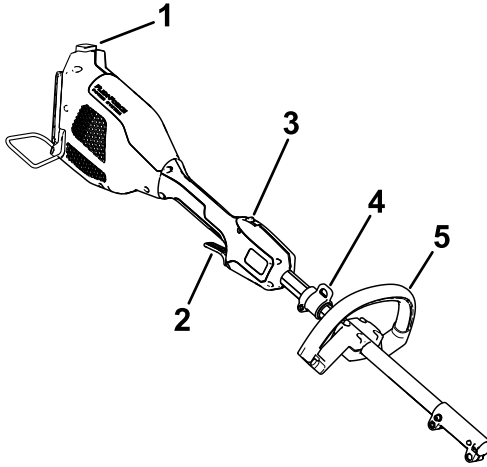

g372329

Figure 5

1. Battery latch
2. Run trigger
3. Lockout button
4. Harness/strap collar (harness/strap sold separately)
5. Auxiliary handle

Specifications

Model	51810T
Charger Type	Flex-Force 60V lithium-ion chargers
Battery Type	Flex-Force 60V lithium-ion batteries

Appropriate Temperature Ranges

Charge/store the battery pack at	5°C (41°F) to 40°C (104°F)*
Use the battery pack at	-30°C (-22°F) to 49°C (120°F)
Use the trimmer at	0°C (32°F) to 49°C (120°F)
Store the trimmer at	0°C (32°F) to 49°C (120°F)*

*Charging time will increase if you do not charge the battery within this range.

Store the tool, battery pack, and battery charger in an enclosed clean, dry area.

Attachments/Accessories

A selection of Toro approved attachments and accessories is available for use with the machine to enhance and expand its capabilities. Contact your Authorized Service Dealer or authorized Toro distributor or go to www.Toro.com for a list of all approved attachments and accessories.

To ensure optimum performance and continued safety certification of the machine, use only genuine Toro replacement parts and accessories. Replacement parts and accessories made by other manufacturers could be dangerous.

Operation

Starting the Attachment

⚠ WARNING

Do not attempt to operate the power head without an attachment installed.

Read and follow the *Operator's Manual* for your specific attachment before operating the power head.

1. Ensure that the vents on the attachment, power head, and battery are clear of any dust and debris.
2. Align the cavity in the battery pack with the tongue on the handle housing ([Figure 6](#)).

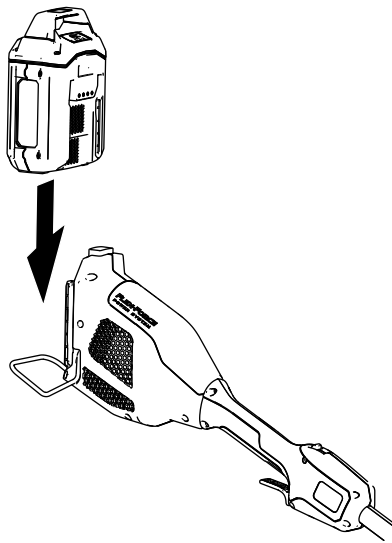

Figure 6

g357444

3. Push the battery pack into the handle until the battery locks into the latch.
4. To start the attachment, press the lockout button, then squeeze the run trigger ([Figure 7](#)).

Note: Slide the 2-speed switch to change the speed of the attachment.

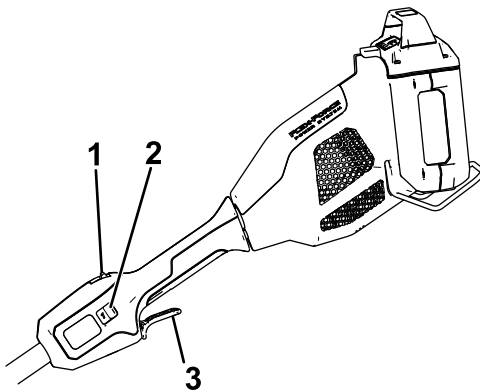

Figure 7

g357456

1. Lockout button
2. 2-speed switch

3. Run trigger

Shutting Off the Attachment

To shut off the attachment, release the run trigger.

Whenever you are not using the attachment or are transporting the trimmer to or from the work area, remove the battery pack.

Removing the Battery Pack from the Power Head

Press the battery latch on the machine to release the battery pack and slide the battery pack out of the machine (Figure 8).

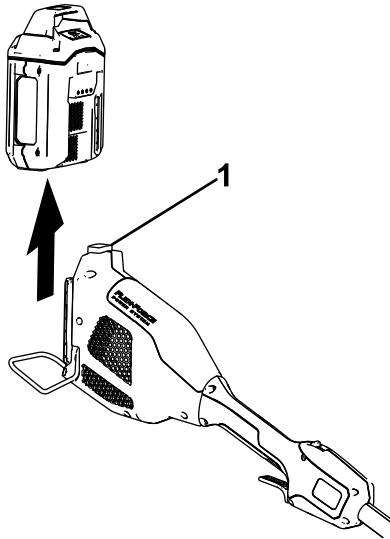

Figure 8

g357457

1. Battery latch

Removing the Attachment from the Power Head

To remove the attachment from the power head, refer to the *Operator's Manual* for your attachment.

Maintenance

After each use of the power head, complete the following:

1. Remove the battery from the power head.
2. Wipe the power head clean with a damp cloth. Do not hose the power head down or submerge it in water.
3. Check and tighten all fasteners. If any part is damaged or lost, repair or replace it.
4. Brush debris away from air intake vents and exhaust on motor housing to prevent the motor from overheating.
5. Refer to your attachment *Operator's Manual* for additional maintenance instructions.

Storage

Important: Store the tool, battery pack, and charger only in temperatures that are within the appropriate range; refer to [Specifications \(page 12\)](#).

Important: If you are storing the battery pack for the off-season, remove the battery pack from the tool and charge the battery pack until 1 or 2 LED indicators turn green on the battery. Do not store a fully charged or fully depleted battery. When you are ready to use the tool again, charge the battery pack until the left indicator light turns green on the charger or all 4 LED indicators turn green on the battery.



- Disconnect the product from the power supply (i.e., remove the plug from the power supply or the battery pack) and check for damage after use.
- Do not store the tool with the battery pack installed.
- Clean all foreign material from the product.
- When not in use, store the tool, battery pack, and battery charger out of the reach of children.
- Keep the tool, battery pack, and battery charger away from corrosive agents, such as garden chemicals and de-icing salts.
- To reduce the risk of serious personal injury, do not store the battery pack outside or in vehicles.
- Store the tool, battery pack, and battery charger in an enclosed clean, dry area.

Preparing the Battery Pack for Recycling

Important: Upon removal, cover the terminals of the battery pack with heavy-duty adhesive tape. Do not attempt to destroy or disassemble the battery pack or remove any of its components.



Contact your local municipality or your authorized Authorized Service Dealer or distributor for more information on how to responsibly recycle the battery.

 The Call2Recycle logo is circular with the word "RECYCLE" at the top, "R B R C" in the center, and "Li-ion" at the bottom. The phone number "1-800-822-8837" is written around the bottom edge of the circle.	Lithium-ion battery packs labeled with the Call2Recycle seal can be recycled at any participating retailer or battery recycling facility in the Call2Recycle program (US and Canada only). To locate a participating retailer or facility closest to you, please call 1-800-822-8837 or visit www.call2recycle.org .
 The High Energy Battery (HEB) logo is circular with the text "END-OF-LIFE MANAGEMENT" around the top and "HEBATTERY.ORG" around the bottom. In the center, there is a lightning bolt symbol above the words "LITHIUM ION" and "(Li-ion)".	Lithium-ion battery packs labeled with the High Energy Battery (HEB) seal shown here, and any 60V Flex-Force batteries 6.0 Ah or greater, can be recycled at any participating dealer or retailer in the Call2Recycle HEB program. To locate a participating dealer or retailer closest to you, please visit www.hebattery.org .

If you cannot locate a participating retailer or facility nearby, or have questions about which recycling program your battery pack may qualify for, please visit the customer support site listed in the operator's manual for your tool/equipment for more information on how to responsibly recycle the battery pack.

If you are located outside of the US and Canada, please contact your Authorized Service Dealer or distributor for more information on how to responsibly recycle the battery pack.

Troubleshooting

Perform only the steps described in these instructions. All further inspection, maintenance, and repair work must be performed by an authorized service center or a similarly qualified specialist if you cannot solve the problem yourself.

Always remove the battery from the tool when troubleshooting, inspecting, maintaining, or cleaning the tool.

Problem	Possible Cause	Corrective Action
The tool does not run or does not run continuously.	<ol style="list-style-type: none">1. The battery is not fully installed in the tool.2. The battery pack is not charged.3. The battery pack is over or under the appropriate temperature range.4. There is moisture on the leads of the battery pack.5. The battery pack is damaged.6. There is another electrical problem with the tool.	<ol style="list-style-type: none">1. Remove and then replace the battery into the tool, making sure that it is fully installed and latched.2. Remove the battery pack from the tool and charge it.3. Move the battery pack to a place where it is dry and the temperature is between 5°C (41°F) and 40°C (104°F).4. Allow the battery pack to dry or wipe it dry.5. Replace the battery pack.6. Contact an Authorized Service Dealer.
The tool does not reach full power.	<ol style="list-style-type: none">1. The battery pack charge capacity is too low.2. The air vents are blocked.	<ol style="list-style-type: none">1. Remove the battery pack from the tool and fully charge the battery pack.2. Clean the air vents.

Problem	Possible Cause	Corrective Action
The tool is producing excessive vibration or noise.	<ol style="list-style-type: none"> 1. The attachment is not installed correctly. 2. There is an issue with your attachment. 	<ol style="list-style-type: none"> 1. Refer to your attachment <i>Operator's Manual</i>. 2. Refer to your attachment <i>Operator's Manual</i>.
The battery pack loses charge quickly.	<ol style="list-style-type: none"> 1. The battery pack is over or under the appropriate temperature range. 	<ol style="list-style-type: none"> 1. Move the battery pack to a place where it is dry and the temperature is between 5°C (41°F) and 40°C (104°F).

California Proposition 65 Warning Information

What is this warning?

You may see a product for sale that has a warning label like the following:



WARNING: Cancer and Reproductive Harm—www.p65Warnings.ca.gov.

What is Prop 65?

Prop 65 applies to any company operating in California, selling products in California, or manufacturing products that may be sold in or brought into California. It mandates that the Governor of California maintain and publish a list of chemicals known to cause cancer, birth defects, and/or other reproductive harm. The list, which is updated annually, includes hundreds of chemicals found in many everyday items. The purpose of Prop 65 is to inform the public about exposure to these chemicals.

Prop 65 does not ban the sale of products containing these chemicals but instead requires warnings on any product, product packaging, or literature with the product. Moreover, a Prop 65 warning does not mean that a product is in violation of any product safety standards or requirements. In fact, the California government has clarified that a Prop 65 warning "is not the same as a regulatory decision that a product is 'safe' or 'unsafe.'" Many of these chemicals have been used in everyday products for years without documented harm. For more information, go to <https://oag.ca.gov/prop65/faqs-view-all>.

A Prop 65 warning means that a company has either (1) evaluated the exposure and has concluded that it exceeds the "no significant risk level"; or (2) has chosen to provide a warning based on its understanding about the presence of a listed chemical without attempting to evaluate the exposure.

Does this law apply everywhere?

Prop 65 warnings are required under California law only. These warnings are seen throughout California in a wide range of settings, including but not limited to restaurants, grocery stores, hotels, schools, and hospitals, and on a wide variety of products. Additionally, some online and mail order retailers provide Prop 65 warnings on their websites or in catalogs.

How do the California warnings compare to federal limits?

Prop 65 standards are often more stringent than federal and international standards. There are various substances that require a Prop 65 warning at levels that are far lower than federal action limits. For example, the Prop 65 standard for warnings for lead is 0.5 µg/day, which is well below the federal and international standards.

Why don't all similar products carry the warning?

- Products sold in California require Prop 65 labelling while similar products sold elsewhere do not.
- A company involved in a Prop 65 lawsuit reaching a settlement may be required to use Prop 65 warnings for its products, but other companies making similar products may have no such requirement.
- The enforcement of Prop 65 is inconsistent.
- Companies may elect not to provide warnings because they conclude that they are not required to do so under Prop 65; a lack of warnings for a product does not mean that the product is free of listed chemicals at similar levels.

Why does the manufacturer include this warning?

the manufacturer has chosen to provide consumers with as much information as possible so that they can make informed decisions about the products they buy and use. the manufacturer provides warnings in certain cases based on its knowledge of the presence of one or more listed chemicals without evaluating the level of exposure, as not all the listed chemicals provide exposure limit requirements. While the exposure from the manufacturer products may be negligible or well within the "no significant risk" range, out of an abundance of caution, the manufacturer has elected to provide the Prop 65 warnings. Moreover, if the manufacturer does not provide these warnings, it could be sued by the State of California or by private parties seeking to enforce Prop 65 and subject to substantial penalties. REV A