



Cyclone™ 1000 Debris Blower Sand Pro®

Model No. 08857 - 240000001 and up.

Parts Catalog

Ordering Replacement Parts

To order replacement parts, please supply the part number, the quantity, and the description of each part desired.

Understanding Reference Numbers

Each Identified part in an illustration has a reference number. The reference number for a part also appears in the parts list, along with other information about the part.

This catalog uses two special reference number formats, one to indicate parts in a service assembly and another to indicate the quantity of a given part in an illustration.

Service Assembly Reference Numbers

Parts in service assemblies have reference numbers in the form a:b. The a represents the reference number of the entire service assembly and the b represents a sequential number unique to each part within the service assembly.

For example, a wheel assembly might be identified by reference number 6, the tire by 6:1, the valve by 6:2, and the wheel by 6:3. When you order the assembly identified by reference number 6, you receive all parts identified by reference numbers 6:1, 6:2, and 6:3. However, you may also order any part individually. Reference numbers of this type appear in illustrations and in part lists.

Reference Numbers Indicating Quantity

In an illustration, if a reference number indicates more than one part, the reference number has the form nX y. The n represents the quantity of the part, the X is the multiplication symbol, and the y represents the reference number.

For example, in an illustration, the reference number 2X 37 means that two of the parts identified by reference number 37 are indicated.

Part Description Abbreviations

Part descriptions in this catalog may include the following abbreviations.

AR.	as required	HYD.	hydraulic
ASM.	assembly	INC.	incorporated
CARR.	carriage	LH.	left hand
DEG.	degrees	NI.	nylon insert
FH.	flat head	PPH.	phillips pan head
GA.	gauge	PTH.	phillips truss head
HF.	hex flange	PTO.	power take off
HH.	hex head	RH.	right hand
HHF.	hex head flange	SFH.	slotted fillister head
HHFTF.	hex head flange thread forming	SHH.	slotted hex head
HJ.	hex jam	SHWH.	slotted hex washer head
HLH.	hex lag head	SPH.	slotted pan head
HOC.	height-of-cut	SQH.	square head
HS.	hex	SRH.	slotted round head
HSBH.	hex socket button head	STD.	standard
HSFH.	hex socket flat head	TAP.	self tapping
HSH.	hex socket head	TTH.	torx truss head
HWH.	hex washer head	WH.	wing head
HWHTF.	hex washer head thread forming		

Contents

Description	Page
Blower, Fan and Frame Assembly 3
Pulley, Bracket and Cover Assembly 4

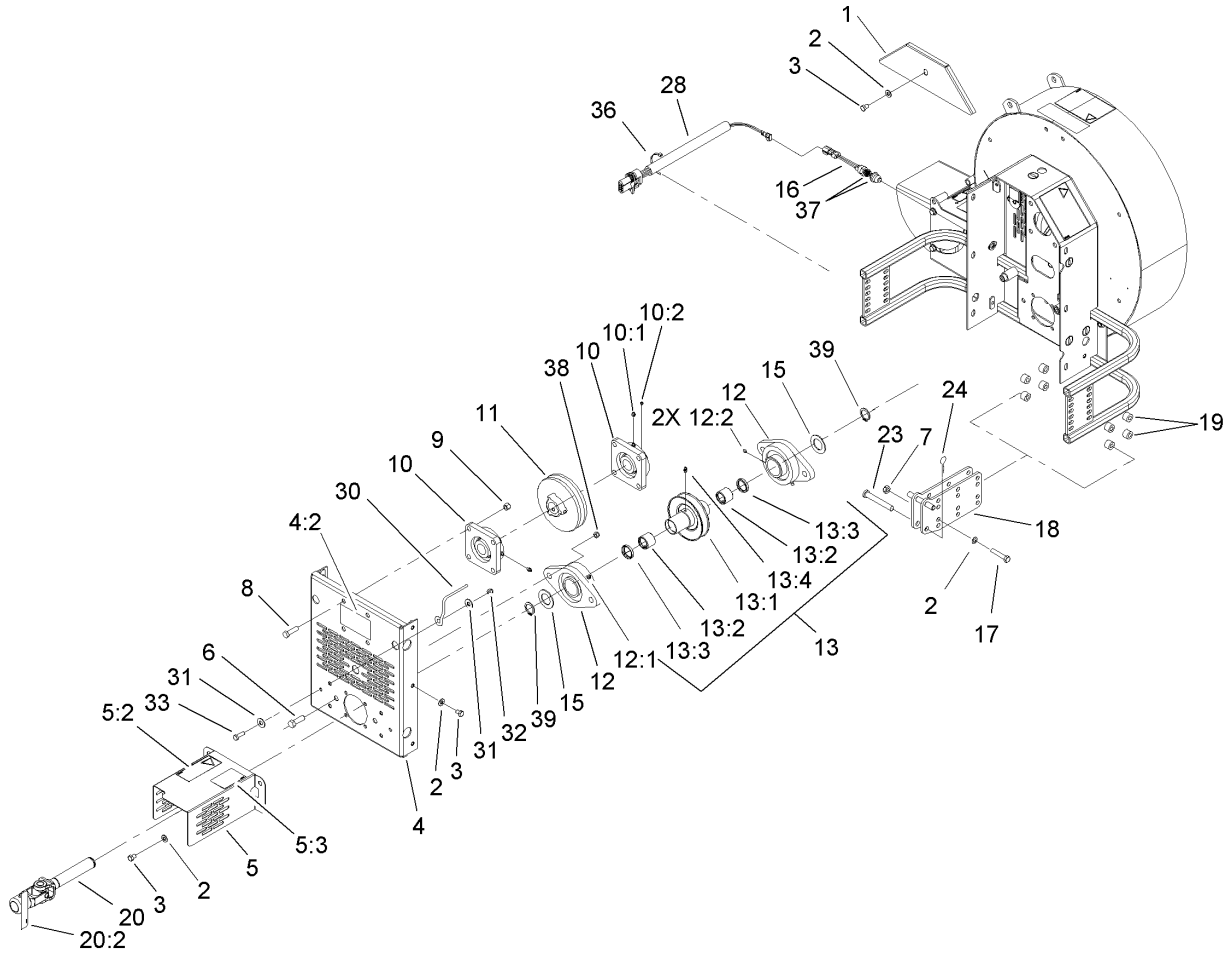

Blower, Fan and Frame Assembly

Ref	Part No.	Qty.	Description
1	98-1155-01	1	Cover
2	3256-24	19	Washer-Flat
3	323-2	11	Screw-HH
4	106-0275	1	Rear Bracket ASM
4:2	105-0709	1	Decal-Warning
5	106-0273	1	PTO Cover ASM
5:2	98-3113	1	Decal-Caution
5:3	98-3137	1	Decal-Points, Grease
6	325-6	4	Screw-HH
7	32146-2	8	Nut-Lock, NI
8	324-6	8	Screw-HH
9	3296-48	8	Nut-Lock, NI
10	94-8987	2	Bearing
10:1	302-52	1	Fitting-Grease
10:2	106-9662	1	Screw-Set,hex Socket
11	98-3139	1	Pulley
12	98-8659	2	Bearing ASM
12:1	302-52	1	Fitting-Grease
12:2	106-9662	2	Screw-Set,hex Socket
13	104-0250	1	Clutch ASM
13:1	98-8680	1	Pulley-Clutch
13:2	71-4580	2	Bearing
13:3	98-1176	2	Seal-Grease
13:4	302-5	1	Fitting-Grease

Ref	Part No.	Qty.	Description
15	98-3138	2	Washer-Thrust
16	94-3429	1	Switch-Ball
17	323-47	8	Screw-HH
18	98-1167	2	Hitch
19	98-1162	16	Spacer-Standoff
20	106-0274	1	Driveshaft ASM
20:2	98-3115	1	Decal-Area, Danger
23	283-78	2	Pin-Clevis
24	3290-355	2	Pin-Hair
28	98-1183	1	Harness-Blower, Debris
30	52-4780	2	Rod-Belt
31	3256-74	4	Washer-Flat
32	3296-69	2	Nut-Lock NI
33	322-5	2	Screw-HH
36	3290-378	1	Tie-Cable
37	3256-69	2	Washer-Flat
38	3296-23	4	Nut-Lock, NI
39	32151-87	2	Ring-Retaining

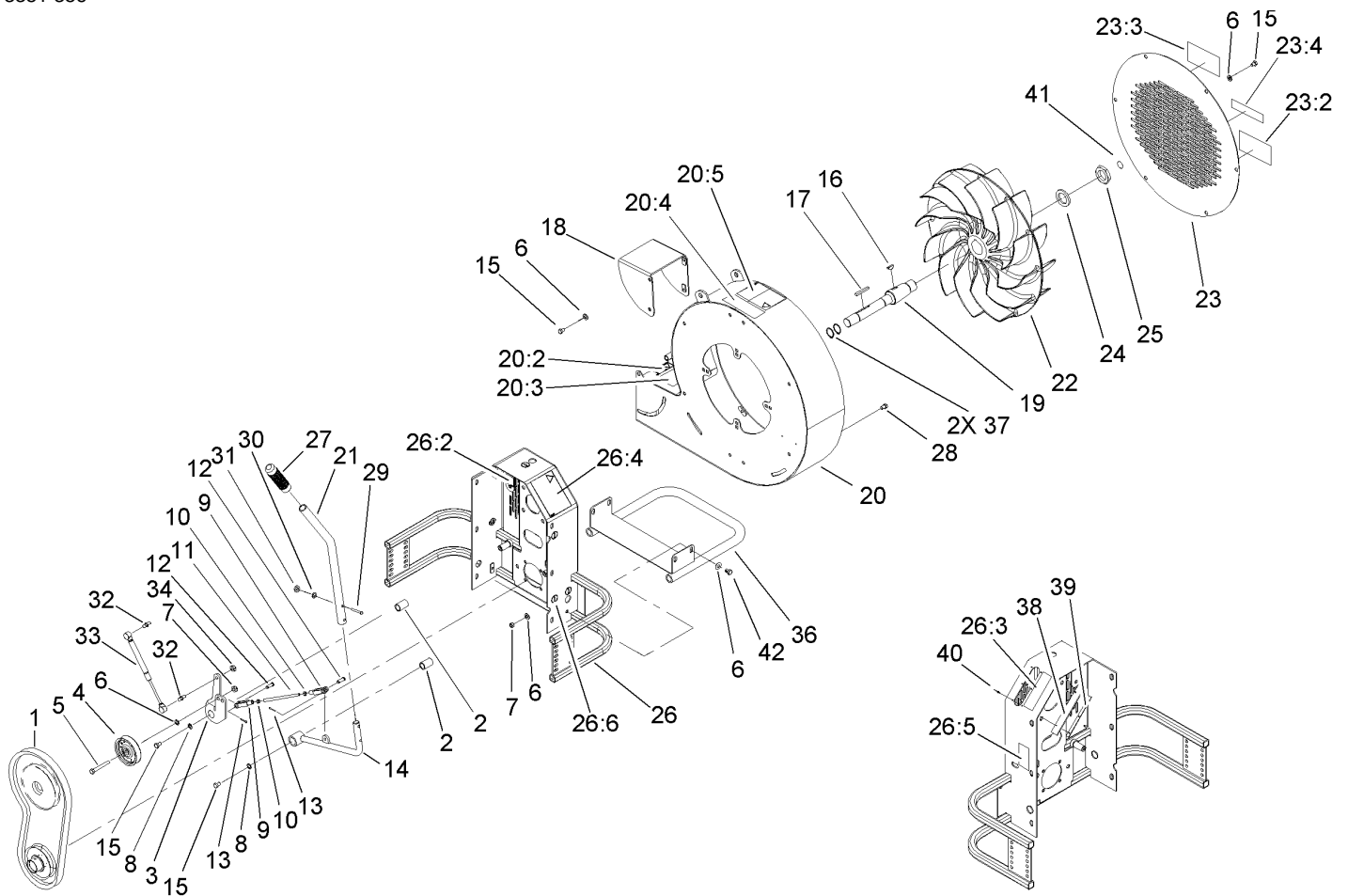

Pulley, Bracket and Cover Assembly

Ref	Part No.	Qty.	Description
1	106-0487	1	Belt-V
2	256-185	2	Bushing
3	98-1117	1	Plate-Pivot
4	36-3220	1	Pulley-Idler
5	323-19	1	Screw-HH
6	3256-24	26	Washer-Flat
7	32146-2	7	Nut-Lock, NI
8	3256-35	2	Washer-Flat
9	282-2	2	Yoke
10	3220-2	2	Nut
11	98-1132	1	Link-Connect
12	283-1	2	Pin-Clevis
13	3272-10	2	Pin-Cotter
14	98-1113	1	Lever-Clutch
15	323-2	10	Screw-HH
16	3257-42	1	Key-Woodruff
17	5-1718	1	Key-Clutch
18	98-1140-01	1	Chute-Fan
19	98-1154	1	Shaft-Fan
20	106-0240	1	Fan Scroll ASM
20:2	93-6674	1	Decal-Warning
20:3	105-0708	1	Decal-Danger
20:4	105-0707	1	Decal-Ansi
20:5	98-3110	1	Decal-Caution

Ref	Part No.	Qty.	Description
21	98-1116-01	1	Lever-Clutch
22	94-8950	1	Fan
23	106-0241	1	Front Screen ASM
23:2	98-7213	1	Decal-Cyclone 1000
23:3	67-1300	1	Decal
23:4	93-9083	1	Decal-Caution
24	77-0950	1	Washer-Castor
25	3218-17	1	Nut-Jam
26	106-0242	1	Frame ASM
26:2	98-3114	1	Decal-Warning
26:3	98-3116	1	Decal-Engagement
26:4	98-3110	1	Decal-Caution
26:5	98-3112	1	Decal-Caution
26:6	58-6520	5	Decal-Grease
27	95-0886	1	Grip
28	98-8666	6	Bolt-Elevator
29	321-13	2	Screw-HH
30	3256-72	2	Washer-Flat
31	32146-17	2	Nut-Lock
32	98-3104	2	Stud-Ball
33	98-3103	1	Strut
34	3218-2	2	Nut-Jam
36	98-8657-01	1	Bar-Skid
37	32120-33	2	Ring-Retaining

NOTES

NOTES

