



**Count on it.**

**Operator's Manual**

# Greensmaster® 3400 TriFlex® Traction Unit

Model No. 04520—Serial No. 417400000 and Up

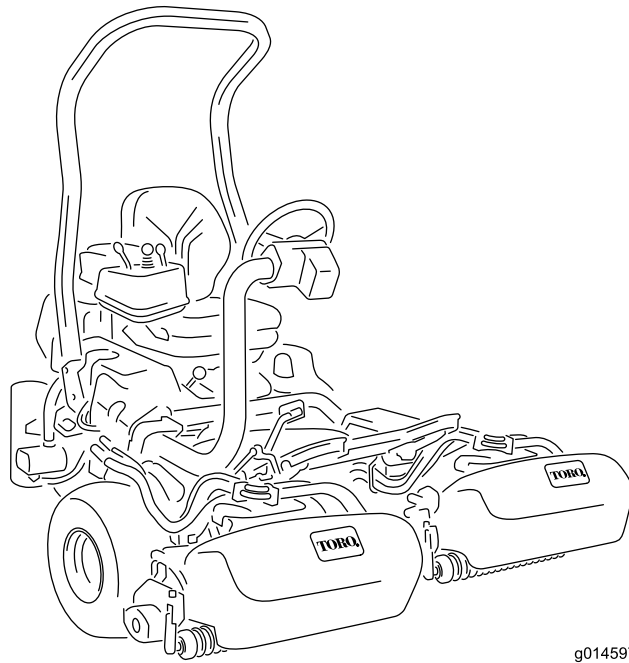

g014597



This product complies with all relevant European directives; for details, please see the separate product specific Declaration of Conformity (DOC) sheet.

It is a violation of California Public Resource Code Section 4442 or 4443 to use or operate the engine on any forest-covered, brush-covered, or grass-covered land unless the engine is equipped with a spark arrester, as defined in Section 4442, maintained in effective working order or the engine is constructed, equipped, and maintained for the prevention of fire.

The enclosed engine owner's manual is supplied for information regarding the US Environmental Protection Agency (EPA) and the California Emission Control Regulation of emission systems, maintenance, and warranty. Replacements may be ordered through the engine manufacturer.

If this machine is equipped with a telematics device, refer to your authorized Toro distributor for instructions to activate the device.

**⚠ WARNING**

**CALIFORNIA  
Proposition 65 Warning**

**Diesel engine exhaust and some of its constituents are known to the State of California to cause cancer, birth defects, and other reproductive harm.**

**Battery posts, terminals, and related accessories contain lead and lead compounds, chemicals known to the State of California to cause cancer and reproductive harm. Wash hands after handling.**

**Use of this product may cause exposure to chemicals known to the State of California to cause cancer, birth defects, or other reproductive harm.**

# Introduction

This machine is a ride-on, reel-blade greens mower intended to be used by professional, hired operators in commercial applications. It is primarily designed for cutting grass on well-maintained turf. Using this product for purposes other than its intended use could prove dangerous to you and bystanders.

Read this information carefully to learn how to operate and maintain your product properly and to avoid

injury and product damage. You are responsible for operating the product properly and safely.

Visit [www.Toro.com](http://www.Toro.com) for more information, including safety tips, training materials, accessory information, help finding a dealer, or to register your product.

Whenever you need service, genuine Toro parts, or additional information, contact an authorized Toro distributor and have the model and serial numbers of your product ready. **Figure 1** identifies the location of the model and serial numbers on the product. Write the numbers in the space provided.

**Important:** With your mobile device, you can scan the QR code on the serial number decal (if equipped) to access warranty, parts, and other product information.

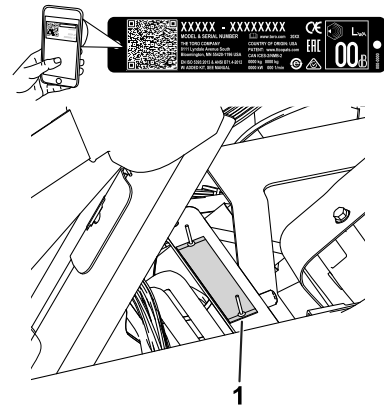

**Figure 1**

g233264

1. Model and serial number location—lift the seat and locate the serial plate.

Model No. _____
Serial No. _____

This manual identifies potential hazards and has safety messages identified by the safety-alert symbol (**Figure 2**), which signals a hazard that may cause serious injury or death if you do not follow the recommended precautions.



**Figure 2**

Safety-alert symbol

g000502

This manual uses 2 words to highlight information. **Important** calls attention to special mechanical

information and **Note** emphasizes general information worthy of special attention.

# Contents

Safety .....	4	Replacing the Fuel Filter/Water Separator .....	37
General Safety .....	4	Inspecting the Fuel Lines and Connections .....	37
Safety and Instructional Decals .....	4	Electrical System Maintenance .....	38
Setup .....	9	Electrical System Safety .....	38
1 Installing the Roll Bar .....	10	Disconnecting the Battery .....	38
2 Installing the Seat .....	10	Connecting the Battery .....	38
3 Installing the Service and Clip Decals .....	10	Charging the Battery .....	39
4 Installing the Steering Wheel .....	11	Locating the Fuses .....	39
5 Installing the Telematics Device .....	11	Drive System Maintenance .....	40
6 Charging the Battery .....	14	Checking the Tire Pressure .....	40
7 Installing the Oil Cooler .....	14	Checking the Torque of the Front Wheel Hub Nuts .....	40
8 Installing the Grass-Basket Hooks .....	15	Checking the Torque of the Wheel Nuts .....	40
9 Installing the Cutting Units .....	16	Adjusting the Transmission for Neutral .....	40
10 Installing the CE Guard Kit .....	16	Adjusting the Transport Speed .....	41
11 Installing the CE Decals .....	16	Adjusting the Mowing Speed .....	42
12 Reducing the Tire Pressure .....	17	Cooling System Maintenance .....	42
13 Burnishing the Brakes .....	17	Cooling System Safety .....	42
Product Overview .....	18	Cleaning the Radiator Screen .....	42
Controls .....	18	Checking the Engine-Coolant Level .....	43
Specifications .....	22	Brake Maintenance .....	43
Attachments/Accessories .....	22	Burnishing the Brakes .....	43
Before Operation .....	22	Adjusting the Brakes .....	43
Before Operation Safety .....	22	Belt Maintenance .....	44
Fuel Specification .....	23	Adjusting the Alternator Belt .....	44
Filling the Fuel Tank .....	23	Hydraulic System Maintenance .....	44
Performing Daily Maintenance .....	23	Hydraulic System Safety .....	44
During Operation .....	24	Servicing the Hydraulic Fluid .....	44
During Operation Safety .....	24	Checking the Hydraulic Lines and Hoses .....	46
Breaking in the Machine .....	25	Cutting Unit Maintenance .....	47
Starting the Engine .....	25	Blade Safety .....	47
Checking the Machine after Starting the Engine .....	25	Installing and Removing the Cutting Units .....	47
Shutting Off the Engine .....	26	Checking the Reel-to-Bedknife Contact .....	49
Checking the Safety-Interlock System .....	26	Backlapping the Reels .....	49
Driving the Machine without Mowing .....	27	Setting the Reel Speed .....	50
Mowing the Green .....	27	Reel Speed Table .....	51
After Operation .....	29	Diagnostics System .....	51
After Operation Safety .....	29	Diagnosing the Service Indicator Light .....	51
Inspecting and Cleaning after Mowing .....	29	Storage .....	52
Hauling the Machine .....	30	Storage Safety .....	52
Towing the Machine .....	30	Preparing the Machine for Storage .....	52
Maintenance .....	31		
Maintenance Safety .....	31		
Recommended Maintenance Schedule(s) .....	32		
Daily Maintenance Checklist .....	33		
Engine Maintenance .....	34		
Engine Safety .....	34		
Servicing the Air Cleaner .....	34		
Servicing the Engine Oil .....	34		
Fuel System Maintenance .....	36		
Draining Water from the Fuel Filter .....	36		

# Safety

## General Safety

This product is capable of amputating hands and feet and of throwing objects.

- Read and understand the contents of this *Operator's Manual* before starting the engine.
- Use your full attention while operating the machine. Do not engage in any activity that causes distractions; otherwise, injury or property damage may occur.
- Do not put your hands or feet near moving components of the machine.
- Do not operate the machine without all guards and other safety protective devices in place and functioning properly on the machine.

- Keep bystanders and children out of the operating area. Never allow children to operate the machine.
- Shut off the machine, remove the key, and wait for all movement to stop before you leave the operator's position. Allow the machine to cool before adjusting, servicing, cleaning, or storing it.

Improperly using or maintaining this machine can result in injury. To reduce the potential for injury, comply with these safety instructions and always pay attention to the safety-alert symbol **▲**, which means Caution, Warning, or Danger—personal safety instruction. Failure to comply with these instructions may result in personal injury or death.

## Safety and Instructional Decals



Safety decals and instructions are easily visible to the operator and are located near any area of potential danger. Replace any decal that is damaged or missing.



### Battery Symbols

Some or all of these symbols are on your battery.

- |  |   |
|--|---|
| 1. Explosion hazard                    | 6. Keep bystanders away from the battery.                                       |
| 2. No fire, open flame, or smoking     | 7. Wear eye protection; explosive gases can cause blindness and other injuries. |
| 3. Caustic liquid/chemical burn hazard | 8. Battery acid can cause blindness or severe burns.                            |
| 4. Wear eye protection.                | 9. Flush eyes immediately with water and get medical help fast.                 |
| 5. Read the <i>Operator's Manual</i> . | 10. Contains lead; do not discard   |



### 106-6755

decal106-6755

- |   |  |
|---|--|
| 1. Engine coolant under pressure.                       | 3. Warning—do not touch the hot surface.       |
| 2. Explosion hazard—read the <i>Operator's Manual</i> . | 4. Warning—read the <i>Operator's Manual</i> . |

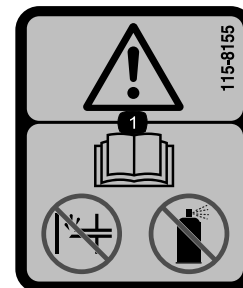

### 115-8155

decal115-8155

1. Warning—read the *Operator's Manual*, do not prime or use starting fluid.

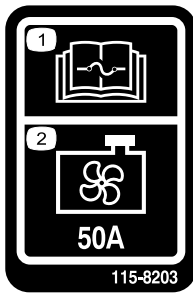

**115-8203**

decal115-8203

1. Read the *Operator's Manual* for fuse information.
2. Radiator fan—50 A

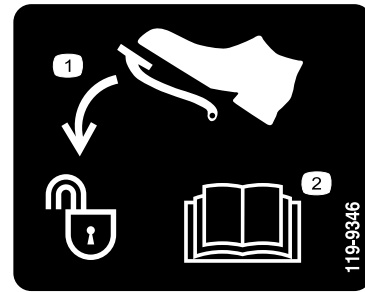

**119-9346**

decal119-9346

1. Press the pedal to unlock.
2. Read the *Operator's Manual* for more information.

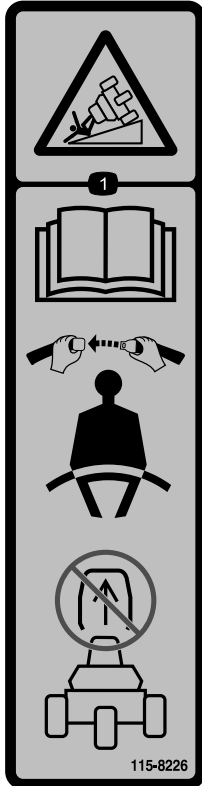

**115-8226**

decal115-8226

1. Tipping hazard—read the *Operator's Manual*; wear a seatbelt; do not remove the roll bar.

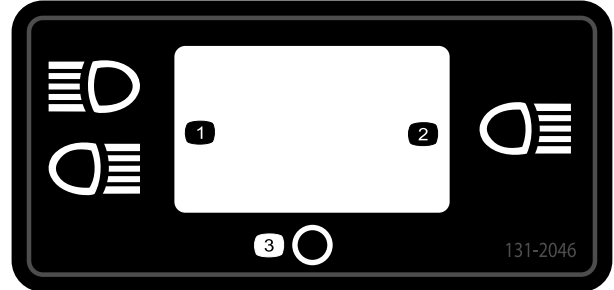

**131-2046**

decal131-2046

1. Double lights
2. Single light
3. Off

**⚠ WARNING: Cancer and Reproductive Harm - [www.P65Warnings.ca.gov](http://www.P65Warnings.ca.gov).**  
 For more information, please visit [www.tcoCAProp65.com](http://www.tcoCAProp65.com)  
**CALIFORNIA SPARK ARRESTER WARNING**  
 Operation of this equipment may create sparks that can start fires around dry vegetation. A spark arrester may be required. The operator should contact local fire agencies for laws or regulations relating to fire prevention requirements.

**133-8062**

decal133-8062

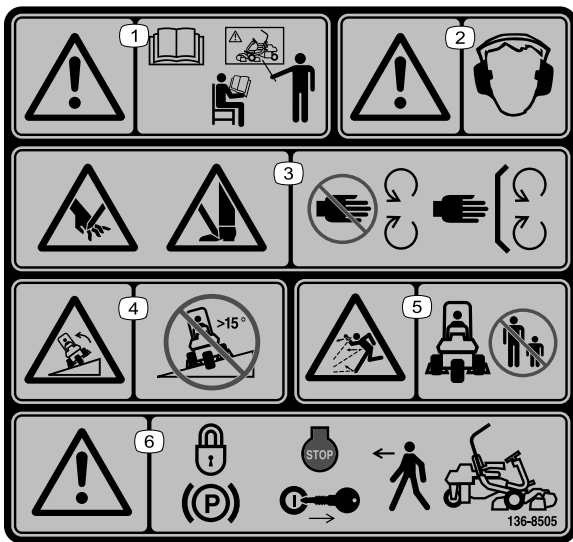

136-8505

decal136-8505

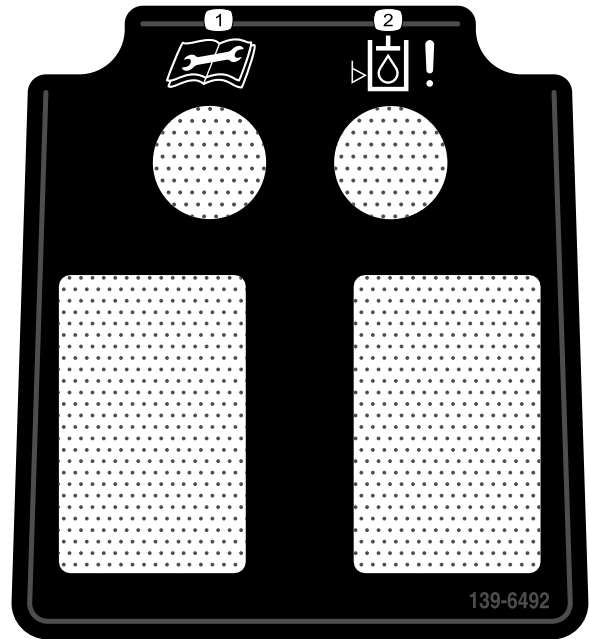

139-6492

decal139-6492

**Note:** This machine complies with the industry standard stability test in the static lateral and longitudinal tests with the maximum recommended slope indicated on the decal. Review the instructions for operating the machine on slopes in the *Operator's Manual* as well as the conditions in which you would operate the machine to determine whether you can operate the machine in the conditions on that day and at that site. Changes in the terrain can result in a change in slope operation for the machine. If possible, keep the cutting units lowered to the ground while operating the machine on slopes. Raising the cutting units while operating on slopes can cause the machine to become unstable.

1. Read the *Operator's Manual* before performing maintenance.
2. Low hydraulic fluid level indicator

1. Warning—read the *Operator's Manual*; receive training before operating the machine.
2. Warning—hearing protection must be worn.
3. Cutting/dismemberment hazard of hands or feet—keep all guards and shields in place.
4. Tipping hazard—do not use on slopes greater than 15°.
5. Thrown object hazard—keep bystanders out of the operating area.
6. Warning—engage the parking brake, shut off the engine, and remove the ignition key before leaving the machine.

GREENSMaster 3400/3420 TriFlex QUICK REFERENCE AID SEE OPERATOR'S MANUAL

CHECK/SERVICE (daily)

1. OIL LEVEL-ENGINE
2. OIL LEVEL-HYDRAULIC TANK
3. BRAKE FUNCTION
4. INTERLOCK SYSTEM:
  - 4a. SEAT INTERLOCK
  - 4b. NEUTRAL SENSOR
  - 4c. MOW SENSOR
  - 4d. PARKING BRAKE INTERLOCK
5. WATER SEPARATOR / FUEL FILTER
6. AIR CLEANER
7. RADATOR SCREEN
8. TIRE PRESSURE (12-15 psi)
9. BATTERY
10. FUEL - DIESEL #2
11. WHEEL NUT TORQUE (70-90 FT LBS)
12. FAN / ALTERNATOR / WATER PUMP BELT
13. COOLANT LEVEL
14. REEL SPEED / BACKLAP CONTROL

FLUID SPECIFICATIONS / CHANGE INTERVALS

See operator's manual for initial change	FLUID TYPE	CAPACITY	CHANGE INTERVALS	FILTER	PART NO.	
	L	QT.	FLUID	FLUID		
A. ENGINE OIL	SAE 15W-40 D114	3.7	3.4*	100 HRS.	100 HRS.	111-51152
B. HYDRAULIC OIL	SEE OPERATOR'S MANUAL	18.9†	20*	2000 HRS.	1000 HRS.	108-51194
C. AIR CLEANER (SEPARATOR-PAPER)					200 HRS.	108-3811
D. FUEL FILTER					500 HRS.	110-9049
E. FUEL TANK	NO. 2 DIESEL	22.7	50*	DRAIN AND FLUSH, 2 YEARS		
F. COOLANT	50/50 ANTIFREEZE/COOLANT	4.4	4.6	DRAIN AND FLUSH, 2 YEARS		

\*Including filter

139-2728

decal139-2728

GREENSMASTER 3XXX							
1	2		3		4		5
	3.8 MPH 6.1 Km/h	5.0 MPH 8.0 Km/h	3.8 MPH 6.1 Km/h	5.0 MPH 8.0 Km/h	3.8 MPH 6.1 Km/h	5.0 MPH 8.0 Km/h	3.8 MPH 6.1 Km/h
0.062" / 1.6mm	N/R	N/R	9	N/R	9	N/R	9
0.094" / 2.4mm	N/R	N/R	9	N/R	9	N/R	9
0.125" / 3.2mm	N/R	N/R	9	N/R	9	N/R	9
0.156" / 4.0mm	N/R	N/R	9	N/R	9	N/R	N/R
0.188" / 4.8mm	N/R	N/R	9	N/R	7	N/R	N/R
0.218" / 5.5mm	N/R	N/R	9	N/R	6	N/R	N/R
0.250" / 6.4mm	7	N/R	6	7	5	7	N/R
0.312" / 7.9mm	6	N/R	5	6	4	6	N/R
0.375" / 9.5mm	6	7	4	5	4	5	N/R
0.438" / 11.1mm	6	6	4	5	3	4	N/R
0.500" / 12.7mm	5	6	3	4	N/R	N/R	N/R
0.625" / 15.9mm	4	5	3	3	N/R	N/R	N/R
0.750" / 19.0mm	3	4	3	3	N/R	N/R	N/R
0.875" / 22.2mm	3	4	N/R	3	N/R	N/R	N/R
1.000" / 25.4mm	3	3	N/R	N/R	N/R	N/R	N/R

115-8156

decal115-8156

- |                         |                          |                          |         |
|-------------------------|--------------------------|--------------------------|---------|
| 1. Reel height          | 3. 8-blade cutting unit  | 5. 14-blade cutting unit | 7. Fast |
| 2. 5-blade cutting unit | 4. 11-blade cutting unit | 6. Reel speed            | 8. Slow |

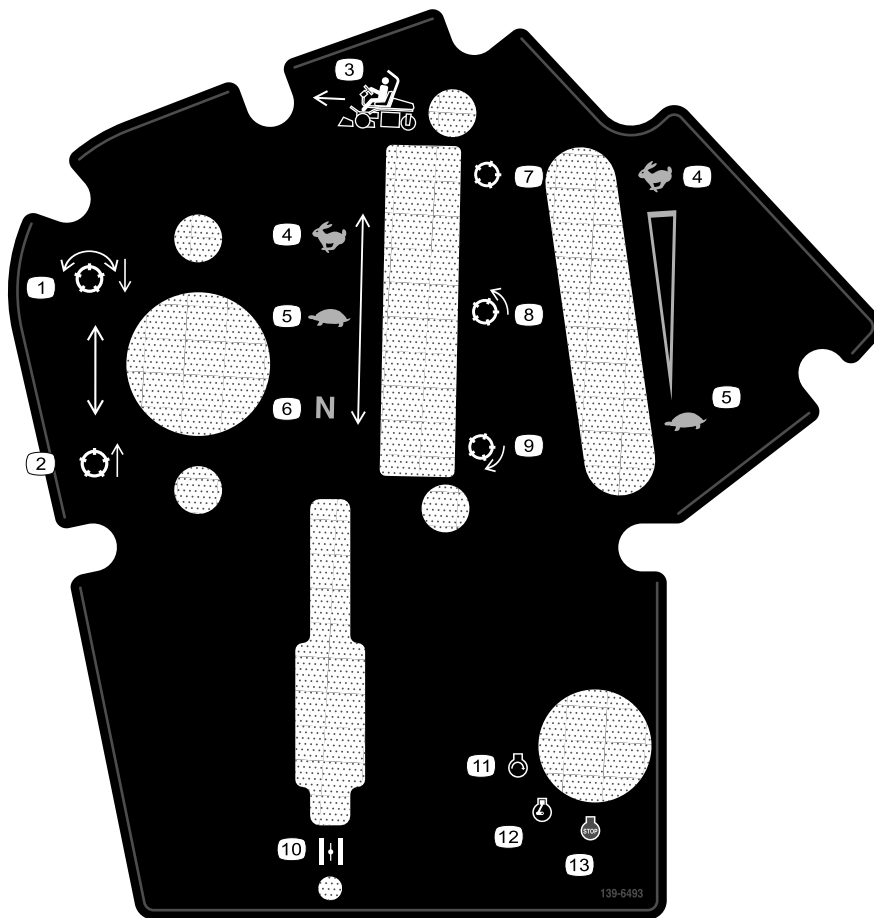

**139-6493**

decal139-6493

- |                                   |                  |
|-----------------------------------|------------------|
| 1. Lower and engage the reels.    | 8. Reel—mow      |
| 2. Raise and disengage the reels. | 9. Reel—backlap  |
| 3. Mow direction                  | 10. Choke        |
| 4. Fast                           | 11. Engine—start |
| 5. Slow                           | 12. Engine—run   |
| 6. Neutral                        | 13. Engine—stop  |
| 7. Reel—transport                 |                  |

# Setup

## Loose Parts

Use the chart below to verify that all parts have been shipped.

Procedure	Description	Qty.	Use
<b>1</b>	Roll bar	1	Install the roll bar.
	Bolt (1/2 x 3-3/4 inches)	4	
	Flange nut (1/2 inch)	4	
<b>2</b>	Seat Kit (order separately; contact your authorized Toro distributor)	1	Install the seat to the base.
<b>3</b>	Service decal (Part No. 139-2728)	1	Install the service and clip decals.
	Clip decal (115-8156)	1	
<b>4</b>	Steering wheel	1	Install the steering wheel.
	Locknut (1-1/2 inches)	1	
	Washer	1	
	Steering-wheel cap	1	
<b>5</b>	Telematics device	1	Install the telematics device.
	Device bracket	1	
	Telematics wire harness	1	
	Hex-head bolt (#10 x 1 inch)	4	
	Locknut (#10)	4	
	U-bolt	1	
	Flange nut (3/8 inch)	2	
Cable tie	4		
<b>6</b>	No parts required	–	Charge the battery.
<b>7</b>	Oil Cooler Kit—Greensmaster 3400 Series Traction Unit (Part No. 117-9314 [purchased separately])	–	Install the optional oil cooler.
<b>8</b>	Grass-basket hook	6	Install the grass-basket hooks.
	Flange bolts	12	
<b>9</b>	Gauge bar	1	Install the cutting units.
	Cutting unit (obtain from your authorized Toro distributor)	3	
	Grass basket	3	
<b>10</b>	CE Guard Kit—Part No. 04442 (sold separately)	1	Install the CE guard kit.
<b>11</b>	Warning decal (Part No. 136-8505)	1	Install the CE decals (if required).
	CE mark decal	1	
	Production year decal	1	
<b>12</b>	No parts required	–	Reduce the tire pressure.
<b>13</b>	No parts required	–	Burnish the brakes.

# 1

## Installing the Roll Bar

### Parts needed for this procedure:

1	Roll bar
4	Bolt (1/2 x 3-3/4 inches)
4	Flange nut (1/2 inch)

### Procedure

1. Remove the top crate support from the crate.
2. Remove the roll bar from the crate.
3. Use 4 bolts (1/2 x 3-3/4 inches) and 4 flange nuts (1/2 inch) to install the roll bar into the ROPS brackets on each side of the machine as shown in [Figure 3](#).

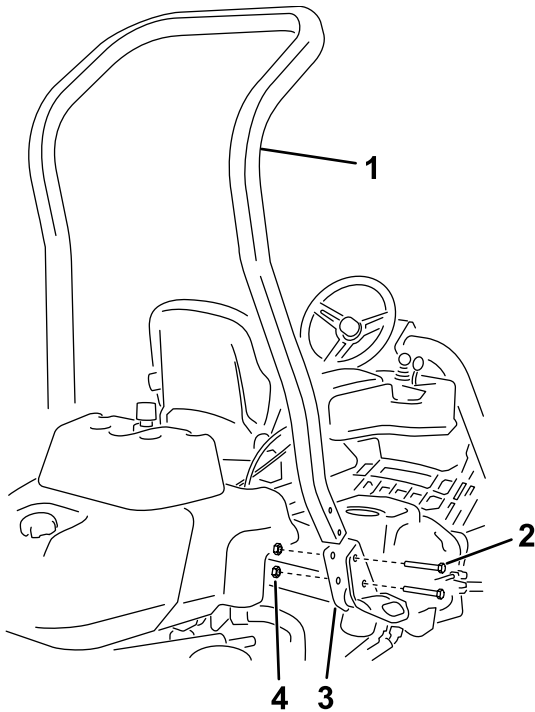

Figure 3

g233739

- |                              |                          |
|------------------------------|--------------------------|
| 1. Roll bar                  | 3. ROPS bracket          |
| 2. Bolt (1/2 x 3-3/4 inches) | 4. Flange nut (1/2 inch) |

4. Torque the fasteners to 136 to 149 N·m (100 to 110 ft-lb).

# 2

## Installing the Seat

### Parts needed for this procedure:

1	Seat Kit (order separately; contact your authorized Toro distributor)
---	---

### Procedure

Acquire your desired seat kit from your distributor and install it to the machine; refer to the kit *Installation Instructions*.

# 3

## Installing the Service and Clip Decals

### Parts needed for this procedure:

1	Service decal (Part No. 139-2728)
1	Clip decal (115-8156)

### Procedure

Install the service decal (Part No. 139-2728) and the clip decal (Part No. 115-8156) to the seat; refer to [Figure 4](#) for the premium seat (Model No. 04719) or [Figure 5](#) for the standard seat (Model No. 04508).

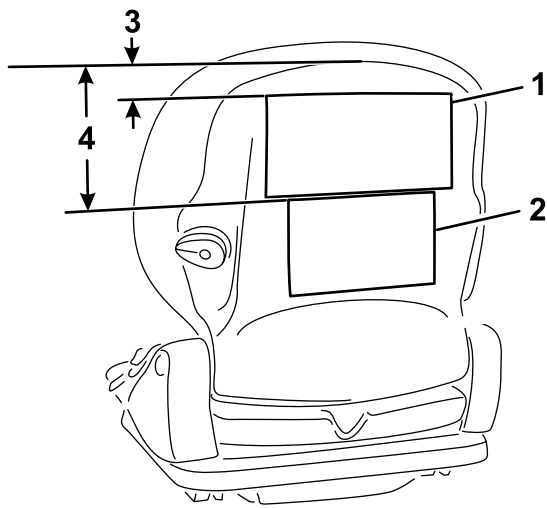
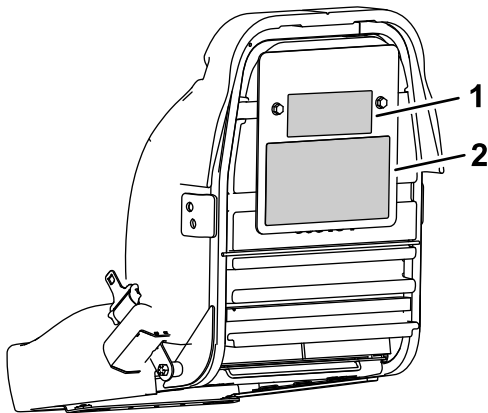

**Figure 4**

Premium Seat (Model No. 04719)

- |                  |                         |
|------------------|-------------------------|
| 1. Service decal | 3. 2.5 cm (1 inch)      |
| 2. Clip decal    | 4. 16.5 cm (6.5 inches) |

g291701



**Figure 5**

Standard Seat (Model No. 04508)

- |               |                  |
|---------------|------------------|
| 1. Clip decal | 2. Service decal |
|---------------|------------------|

g291702

# 4

## Installing the Steering Wheel

Parts needed for this procedure:

1	Steering wheel
1	Locknut (1-1/2 inches)
1	Washer
1	Steering-wheel cap

### Procedure

- Slide the steering wheel onto the steering shaft (Figure 6).

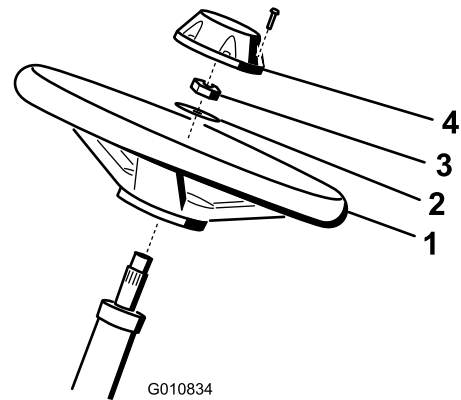

**Figure 6**

- |                   |            |
|-------------------|------------|
| 1. Steering wheel | 3. Locknut |
| 2. Washer         | 4. Cap     |

G010834

g010834

- Slide the washer onto the steering shaft (Figure 6).
- Secure the steering wheel to the shaft with a locknut and tighten it to 27 to 35 N·m (20 to 26 ft-lb) (Figure 6).
- Install the cap to the steering wheel and secure it with 6 bolts (Figure 6).

# 5

## Installing the Telematics Device

### Parts needed for this procedure:

1	Telematics device
1	Device bracket
1	Telematics wire harness
4	Hex-head bolt (#10 x 1 inch)
4	Locknut (#10)
1	U-bolt
2	Flange nut (3/8 inch)
4	Cable tie

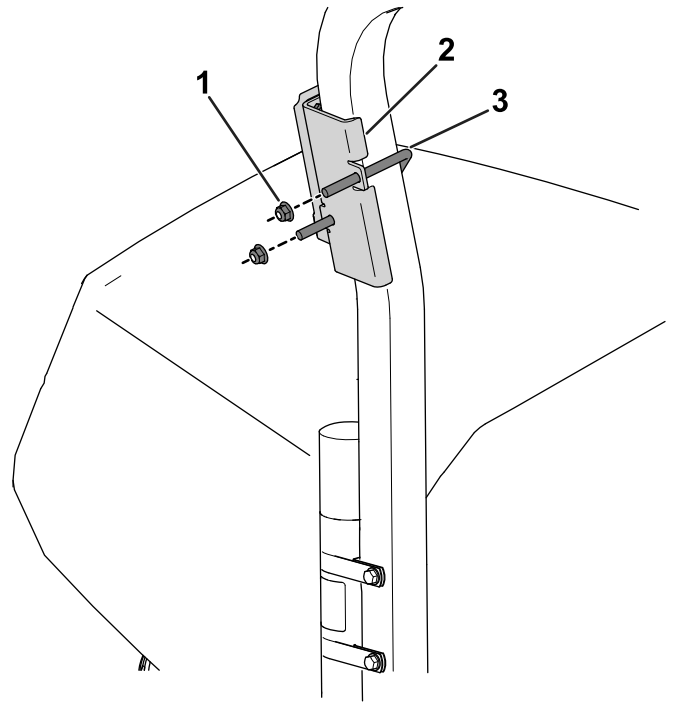

Figure 8

g522342

### Procedure

1. Use 4 hex-head bolts (#10 x 1 inch) and 4 locknuts (#10) to secure the telematics device to the device bracket (Figure 7).

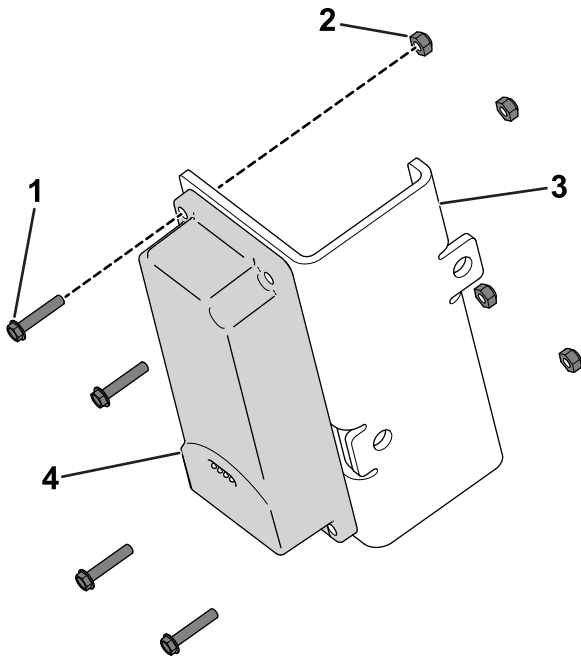

Figure 7

g520691

1. Hex-head bolt (#10 x 1 inch)
2. Locknut (#10)
3. Device bracket
4. Telematics device

2. Use a U-bolt and 2 flange nuts (3/8 inch) to secure the device bracket to the area above the manual tube on the roll bar (Figure 8).

1. Flange nut (3/8 inch)
2. Device bracket
3. U-bolt

3. Install the connector labeled P02 on the telematics wire harness to the telematics device (Figure 9).

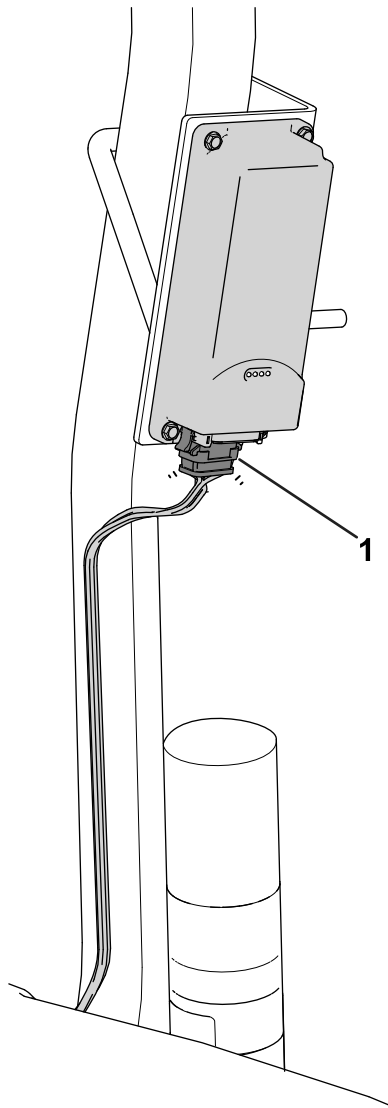
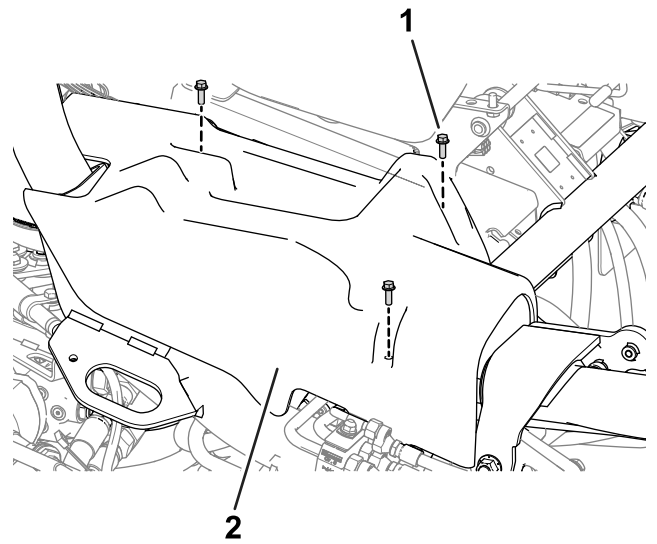

**Figure 9**

g522343

1. Connector labeled P02

4. Remove the right side cover (Figure 10) from the machine.

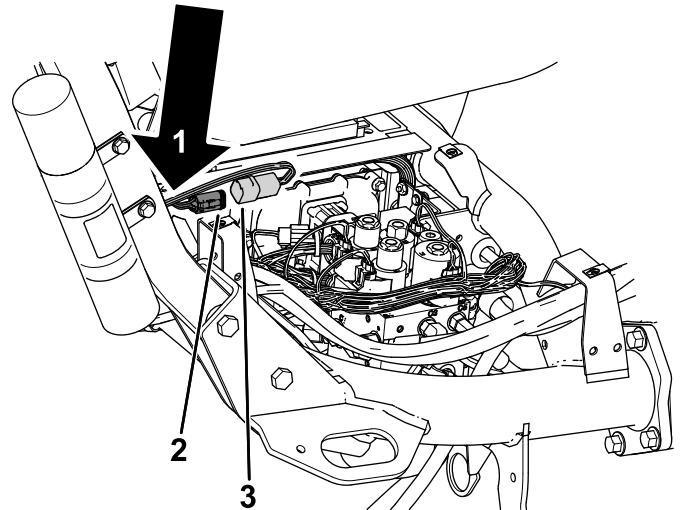

**Figure 10**

g522466

1. Bolt
2. Right side cover

5. Route the wire harness down the roll bar and connect the wire-harness connector labeled P01 to the connector on the machine wire harness labeled P49 (Figure 11).
6. Secure the telematics harness to the main harness with a cable tie (Figure 11).



**Figure 11**

g542372

1. Install cable tie here to secure telematics harness to main harness
2. Connector labeled P49—machine wire harness
3. Connector labeled P01—telematics wire harness

7. Secure the harness to the roll bar using cable ties as shown.

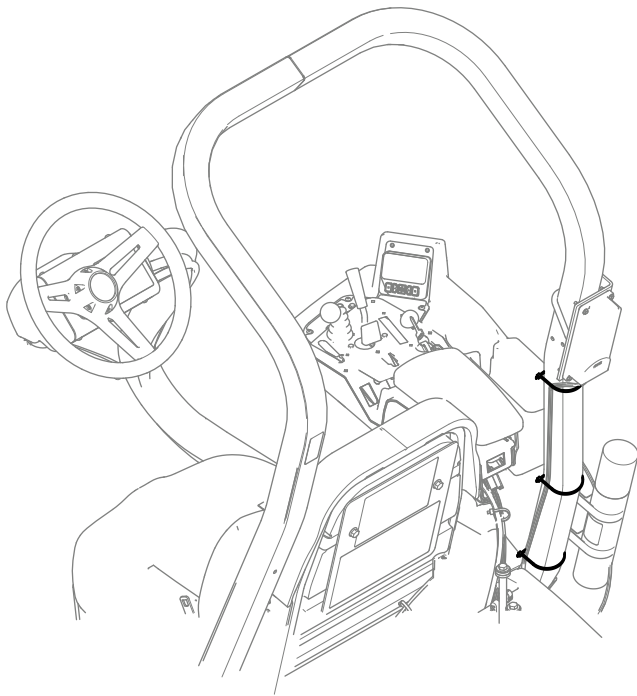

Figure 12

g542369

# 7

## Installing the Oil Cooler

### Optional

Parts needed for this procedure:

-	Oil Cooler Kit—Greensmaster 3400 Series Traction Unit (Part No. 117-9314 [purchased separately])
---	--

### Procedure

If you are operating the machine in hot climates, where the ambient temperature is above 29°C (85°F), or using it for heavy-duty use (mowing other than greens, such as fairways or verticutting), install the optional hydraulic oil cooler kit (Part No. 117-9314).

- 
8. Install the right side cover to the machine ([Figure 10](#)).

# 6

## Charging the Battery

No Parts Required

### Procedure

Charge the battery; refer to [Charging the Battery](#) (page 39).

# 8

## Installing the Grass-Basket Hooks

Parts needed for this procedure:

6	Grass-basket hook
12	Flange bolts

### Procedure

Install the 6 grass-basket hooks onto the ends of the suspension-arm bars using the 12 flange bolts ([Figure 13](#)).

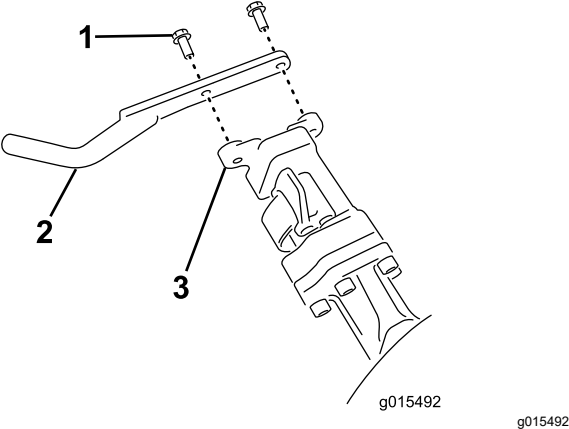

Figure 13

- 1. Flange bolt
- 2. Grass-basket hook
- 3. Suspension-arm bar

# 9

## Installing the Cutting Units

### Parts needed for this procedure:

1	Gauge bar
3	Cutting unit (obtain from your authorized Toro distributor)
3	Grass basket

### Procedure

1. Prepare the cutting units for installation; refer to your cutting unit *Operator's Manual*.
2. Apply grease to the inside diameter of the drive coupler.
3. Install the cutting units; refer to [Installing the Cutting Units \(page 47\)](#).

# 10

## Installing the CE Guard Kit

### Parts needed for this procedure:

1	CE Guard Kit—Part No. 04442 (sold separately)
---	---

### Procedure

Install the CE Guard Kit; refer to the CE Guard Kit for Greensmaster 3400 TriFlex Traction Unit *Installation Instructions*.

# 11

## Installing the CE Decals

### Parts needed for this procedure:

1	Warning decal (Part No. 136-8505)
1	CE mark decal
1	Production year decal

### Procedure

If you use this machine in a country that complies to CE standards, perform the following steps after you install the guard kit to the machine:

- Apply the CE mark decal to the frame under the front of the seat ([Figure 14](#)).

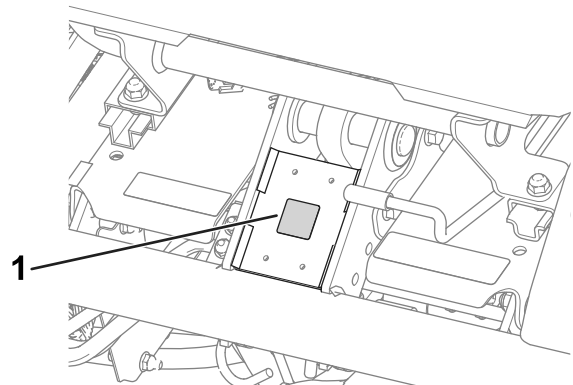
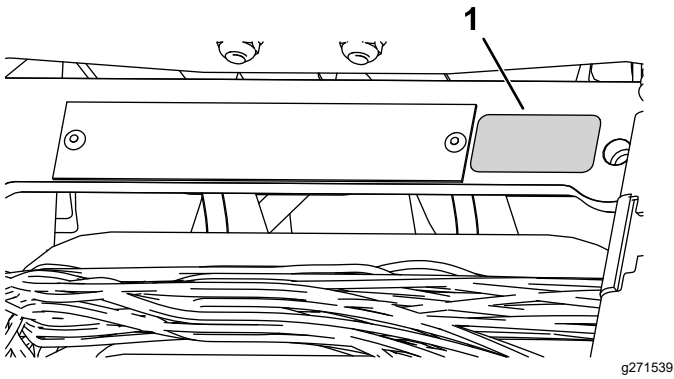

Figure 14

g233420

1. CE mark decal

- Install the production year decal near the serial plate ([Figure 15](#)).



**Figure 15**

g271539

1. Production year decal
- 

# 12

## Reducing the Tire Pressure

**No Parts Required**

### Procedure

The tires are overinflated at the factory for shipping purposes. Reduce the pressure to the proper levels before starting the machine; refer to [Checking the Tire Pressure \(page 40\)](#).

# 13

## Burnishing the Brakes

**No Parts Required**

### Procedure

Burnish the brakes; refer to [Burnishing the Brakes \(page 43\)](#).

# Product Overview

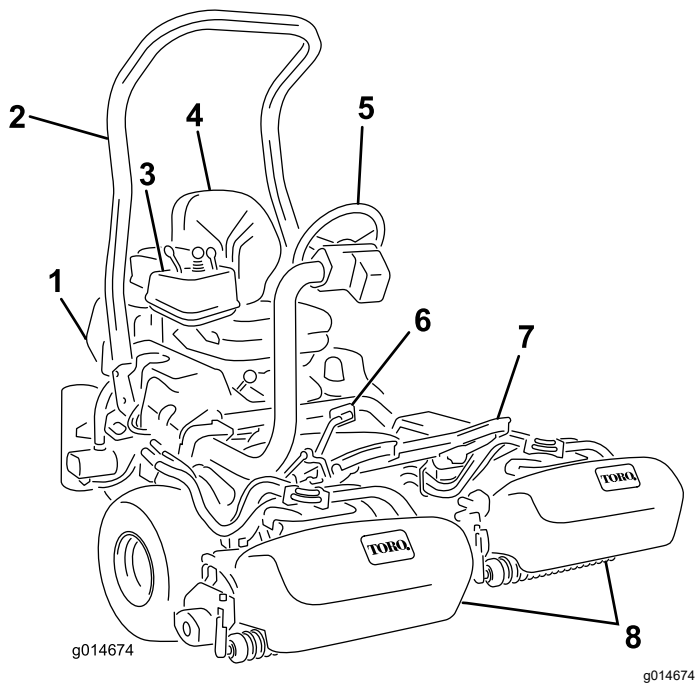

Figure 16

- |                  |                   |
|------------------|-------------------|
| 1. Engine        | 5. Steering wheel |
| 2. Roll bar      | 6. Traction pedal |
| 3. Control panel | 7. Footrest       |
| 4. Seat          | 8. Cutting units  |

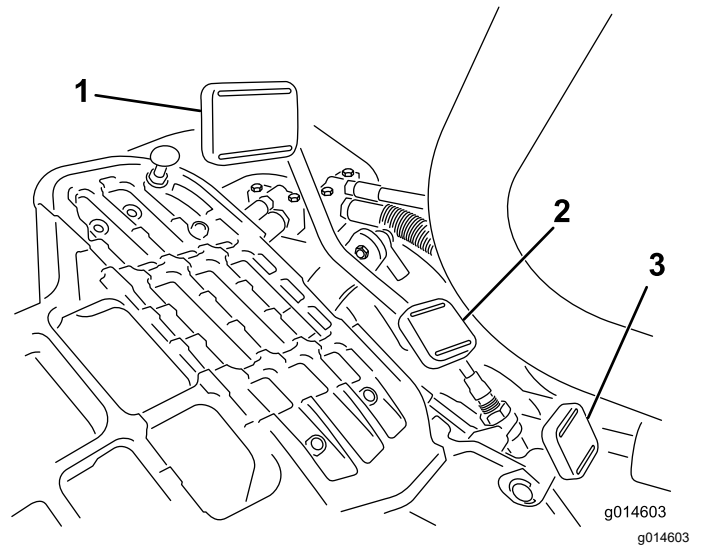

Figure 17

- |                           |                               |
|---------------------------|-------------------------------|
| 1. Traction pedal—forward | 3. Steering-arm-locking pedal |
| 2. Taction pedal—reverse  |                               |

## Controls

### Traction Pedal

The traction pedal (Figure 17) has 3 functions: to make the machine move forward, to move it backward, and to stop the machine. Press the top of the pedal to move forward and the bottom of the pedal to move backward or to assist in stopping when moving forward. Also, allow the pedal to move to the neutral position to stop the machine. For your comfort, do not rest the heel of your foot on the reverse pad of the traction pedal when you are driving the machine forward. (Figure 18).



Figure 18

Ground speeds are as follows:

- 3.2 to 8 km/h (2 to 5 mph) forward mowing speed
- 16 km/h (10 mph) maximum transport speed
- 4.0 km/h (2.5 mph) reverse speed

### Ignition Switch

Insert the key into the switch (Figure 19) and turn it clockwise to the START position to start the engine. Release the key as soon as the engine starts; the key moves to the ON position. Turn the key counterclockwise to the STOP position to shut off the engine.

## Steering-Arm-Locking Pedal

Press the pedal (Figure 17) and raise or lower the steering arm for operator comfort, then, release the pedal to lock the arm in place.

## Throttle Lever

Use the throttle lever (Figure 19) to control the speed of the engine. Move the throttle lever toward the FAST position to increase the engine speed; move it toward the SLOW position to decrease the engine speed.

**Important:** You cannot shut off the engine using the throttle lever.

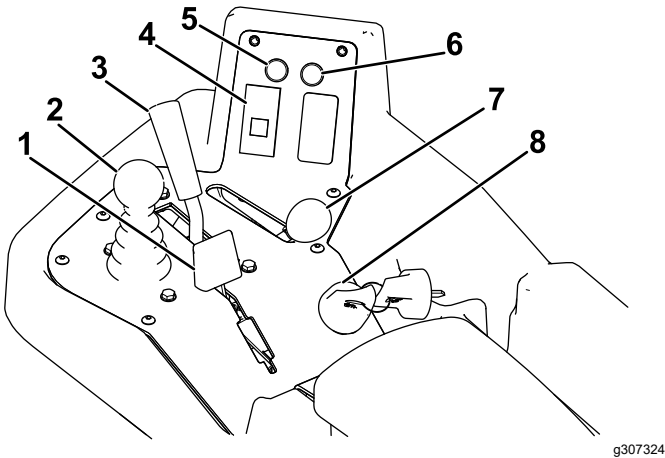

Figure 19

- |                              |                            |
|------------------------------|----------------------------|
| 1. Choke lever               | 5. Service-indicator light |
| 2. Raise/lower mower control | 6. Leak-indicator light    |
| 3. Functional-control lever  | 7. Throttle lever          |
| 4. Engine-oil-pressure light | 8. Ignition switch         |

## Raise/Lower Mow Control

Moving the control (Figure 19) forward during cutting operation lowers the cutting units and starts the reels. Pull back on the control to stop the reels and raise the cutting units. To stop the reels without raising the cutting units, pull back on the control momentarily and releasing it. Start the reels by moving the control forward.

## Functional Control Lever

The functional control lever (Figure 19) provides 2 traction selections plus a NEUTRAL position. You can shift from mow to transport or transport to mow (not to neutral) while the machine is in motion; no damage will result.

- REAR position—neutral position; use when backlapping the reels
- MIDDLE position—use when cutting grass
- FRONT position—use when driving the machine between job sites

## Battery Warning Light

The light (Figure 19) glows if the battery charge is low.

## Engine-Oil Pressure Light

The light (Figure 19) glows if the engine-oil pressure drops below a safe level.

## Water Temperature Light

The light (Figure 19) glows and the engine automatically shuts down when the engine-coolant temperature gets too high. If the engine shuts down, you can start the engine and drive the machine for 10 seconds before it will shutdown again, allowing you to move the machine to a location where you can allow it to cool down.

## Service Indicator Light

The service indicator light (Figure 19) illuminates when the machine sensors detect an issue with 1 of the systems of the machine. If this light illuminates, stop what you are doing and drive to a safe location where you or a service technician can diagnose the problem. For more information on diagnosing system issues using the service indicator light, refer to [Diagnosing the Service Indicator Light \(page 51\)](#).

## Glow-Plug Indicator Light

When the glow-plug indicator light (Figure 19) is lit, it indicates the glow plugs are on.

**Note:** The glow-plug indicator light may illuminate for a short time after the engine has started; this is normal.

## Hour Meter

The hour meter (Figure 20) indicates the total hours the machine has operated. It starts to function whenever you rotate the ignition switch to the ON position.

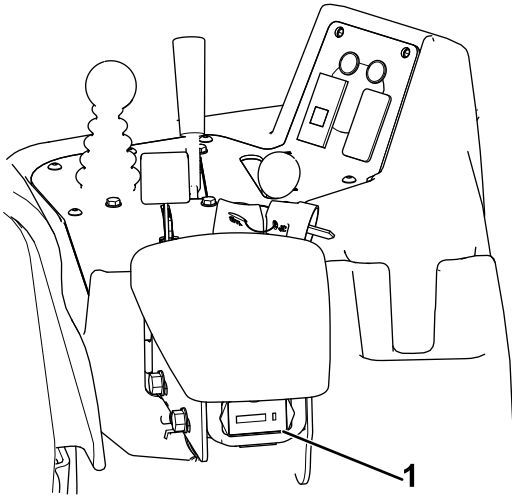

Figure 20

g307330

1. Hour meter

## Parking Brake Lever

Pull the brake lever (Figure 21) to engage the parking brake. Disengage it by squeezing the release lever on the underside of the brake lever and lowering it to the released position. Engage the parking brake whenever you leave the machine.

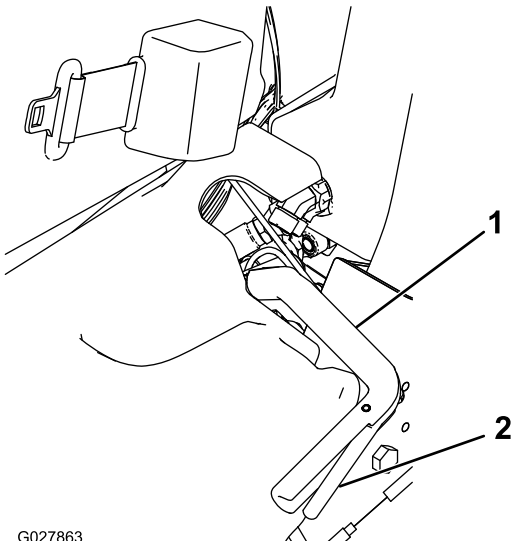

G027863

Figure 21

g027863

1. Parking-brake lever
2. Release lever

## Backlap Lever

The backlap lever is located under the plastic cover to the left of the seat. Use the backlap lever (Figure 22) in conjunction with the raise/lower mower control lever and the reel-speed control for backlapping the reels.

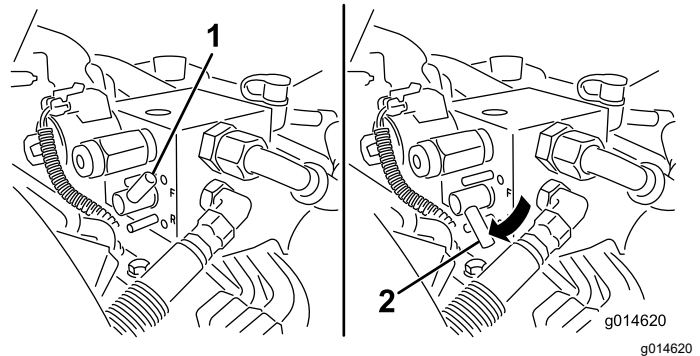

g014620

g014620

Figure 22

1. Backlap lever—mow position
2. Backlap lever—backlap position

## Reel-Speed Control

The reel-speed control is located under the plastic cover to the left of the seat. Use the reel-speed control (Figure 23) to adjust the speed of the reels.

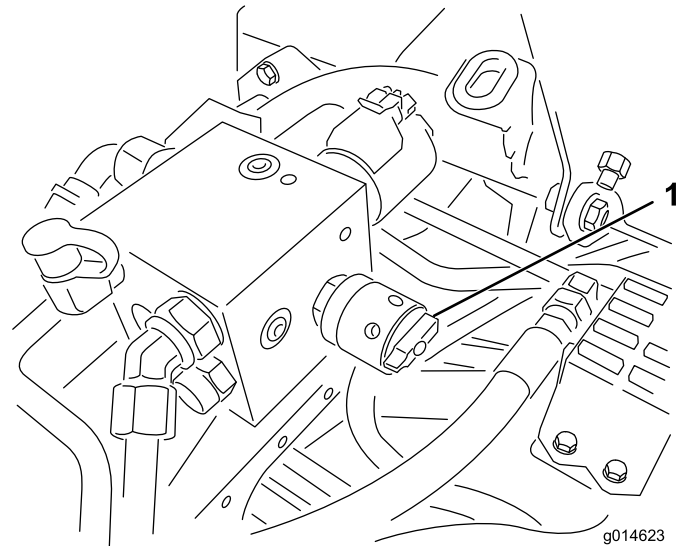

g014623

g014623

Figure 23

1. Reel-speed control

## Seat-Adjusting Lever

The seat-adjusting lever is located on the front, left corner of the seat (Figure 24), allowing you to adjust the seat forward and rearward.

**Note:** If you need additional adjustment on the seat, you can remove the 4 nuts securing the seat slide rails to the base and move the seat slide rails to the second set of mounting holes provided.

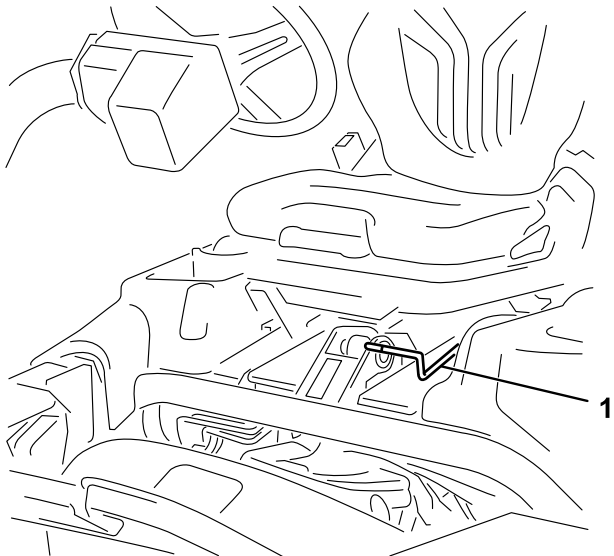

Figure 24

g193737

1. Seat-adjusting handle

## Fuel-Shutoff Valve

Close the fuel-shutoff valve (Figure 25), behind the seat and under the fuel tank, when storing or transporting the machine on a truck or trailer.

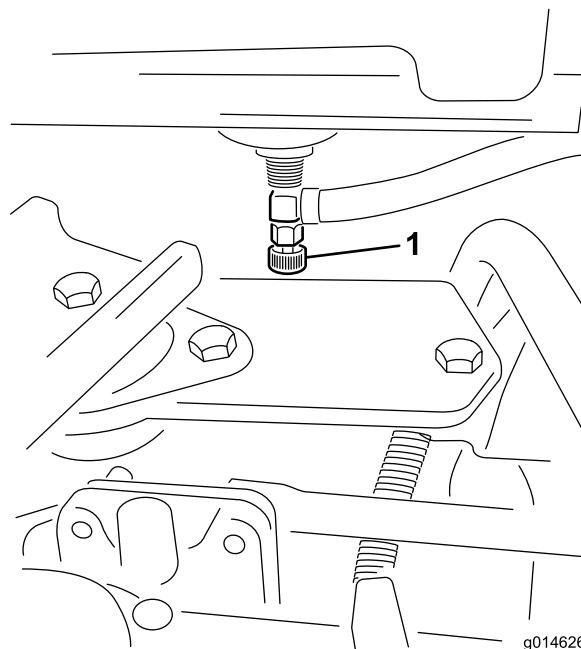

g014626

g014626

Figure 25

1. Fuel shutoff (under the fuel tank)

# Specifications

**Note:** Specifications and design are subject to change without notice.

Width of cut	151 cm (59.5 inches)
Wheel tread (to the center of the tire)	128 cm (50.5 inches)
Wheel tread (to the outside of the tire)	154 cm (60.5 inches)
Minimum ground clearance (at the machine centerline)	11 cm (4.5 inches)
Overall length (w/baskets)	249 cm (98 inches)
Overall width	179 cm (70.6 inches)
Overall height	205 cm (80.8 inches)
Net weight w/reels (11 blade)	695 kg (1,533 lb)

## Attachments/Accessories

A selection of Toro approved attachments and accessories is available for use with the machine to enhance and expand its capabilities. Contact your Authorized Service Dealer or authorized Toro distributor or go to [www.Toro.com](http://www.Toro.com) for a list of all approved attachments and accessories.

To ensure optimum performance and continued safety certification of the machine, use only genuine Toro replacement parts and accessories. Replacement parts and accessories made by other manufacturers could be dangerous, and such use could void the product warranty.

# Operation

**Note:** Determine the left and right sides of the machine from the normal operating position.

## Before Operation

### Before Operation Safety

#### General Safety

- Never allow children or untrained people to operate or service the machine. Local regulations may restrict the age of the operator. The owner is responsible for training all operators and mechanics.
- Become familiar with the safe operation of the equipment, operator controls, and safety signs.
- Engage the parking brake, shut off the machine, remove the key, and wait for all movement to stop before you leave the operator's position. Allow the machine to cool before adjusting, servicing, cleaning, or storing it.
- Know how to stop the machine and shut off the machine quickly.
- Check that operator-presence controls, safety switches, and safety protective devices are attached and functioning properly. Do not operate the machine unless they are functioning properly.
- Before mowing, always inspect the machine to ensure that the cutting units are in good working condition.
- Inspect the area where you will use the machine and remove all objects that the machine could throw.

#### Fuel Safety

- Use extreme care in handling fuel. It is flammable and its vapors are explosive.
- Extinguish all cigarettes, cigars, pipes, and other sources of ignition.
- Use only an approved fuel container.
- Do not remove the fuel cap or fill the fuel tank while the engine is running or hot.
- Do not add or drain fuel in an enclosed space.
- Do not store the machine or fuel container where there is an open flame, spark, or pilot light, such as on a water heater or other appliance.
- If you spill fuel, do not attempt to start the engine; avoid creating any source of ignition until the fuel vapors have dissipated.

# Fuel Specification

- **Fuel tank capacity:** 20.44 L (5.40 U.S. gallons)
- **Recommended Fuel:**
  - For best results, use only clean, fresh diesel fuel or biodiesel fuels with low (<500 ppm) or ultra low (<15 ppm) sulfur content. The minimum cetane rating should be 40. Purchase fuel in quantities that can be used within 180 days to ensure fuel freshness.
  - Use summer-grade diesel fuel (No. 2-D) at temperatures above -7° C (20° F) and winter-grade (No. 1-D or No. 1-D/2-D blend) below that temperature. Using winter-grade fuel at lower temperatures provides lower flash point and cold flow characteristics that will ease starting and reduce fuel filter plugging.

**Note:** Using summer-grade fuel above -7° C (20° F) will contribute toward longer fuel pump life and increased power compared to winter-grade fuel.

- This machine can also use a biodiesel blended fuel of up to B20 (20% biodiesel, 80% petrodiesel). The petrodiesel portion should be low or ultra-low sulfur. Observe the following precautions:
  - ◇ The biodiesel portion of the fuel must meet specification ASTM D6751 or EN14214.
  - ◇ The blended fuel composition should meet ASTM D975 or EN590.
  - ◇ Painted surfaces may be damaged by biodiesel blends.
  - ◇ Use B5 (biodiesel content of 5%) or lesser blends in cold weather.
  - ◇ Monitor seals, hoses, gaskets in contact with fuel as they may be degraded over time.
  - ◇ Fuel filter plugging may be expected for a time after converting to biodiesel blends.
  - ◇ Contact your authorized Toro distributor for more information on biodiesel.

# Filling the Fuel Tank

1. Clean around the fuel-tank cap and remove it (Figure 26).

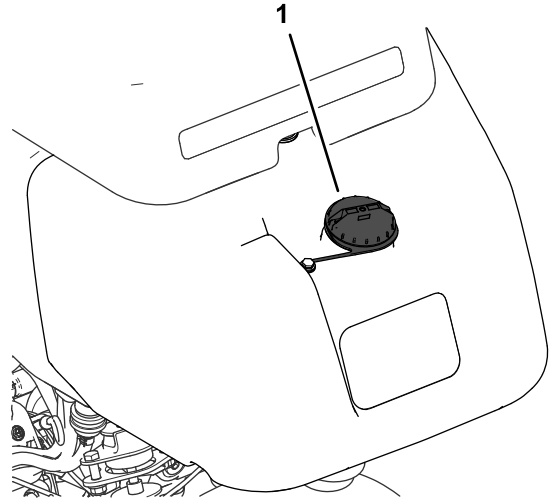

Figure 26

g272992

1. Fuel-tank cap

2. Add the specified fuel to the fuel tank until the level is 25 mm (1 inch) below the bottom of the filler neck. This space in the tank allows the fuel to expand.

**Important:** Do not fill the fuel tank completely full.

3. Install the cap.

**Note:** You will hear a click sound when the cap is secure.

4. Wipe up any spilled fuel.

# Performing Daily Maintenance

**Service Interval:** Before each use or daily

Before starting the machine each day, perform the following procedures:

- Check the engine-oil level.
- Drain water from the fuel filter.
- Check the cooling system.
- Check the tire pressure.
- Check the hydraulic-fluid level.
- Check the reel-to-bedknife contact.

# ***During Operation***

## **During Operation Safety**

### **General Safety**

- The owner/operator can prevent and is responsible for accidents that may cause personal injury or property damage.
- Wear appropriate clothing, including eye protection; long pants; substantial, slip-resistant footwear, and hearing protection. Tie back long hair and do not wear loose clothing or loose jewelry.
- Do not operate the machine while ill, tired, or under the influence of alcohol or drugs.
- Use your full attention while operating the machine. Do not engage in any activity that causes distractions; otherwise, injury or property damage may occur.
- Before you start the engine, ensure that all drives are in neutral, the parking brake is engaged, and you are in the operating position.
- Do not carry passengers on the machine.
- Keep bystanders and children out of the operating area. If co-workers must be present, use caution and ensure that the grass baskets are installed on the machine.
- Operate the machine only in good visibility to avoid holes or hidden hazards.
- Avoid mowing on wet grass. Reduced traction could cause the machine to slide.
- Keep your hands and feet away from the cutting units.
- Look behind and down before backing up to be sure of a clear path.
- Use care when approaching blind corners, shrubs, trees, or other objects that may obscure your vision.
- Stop the cutting units whenever you are not mowing.
- Slow down and use caution when making turns and crossing roads and sidewalks with the machine. Always yield the right-of-way.
- Operate the engine only in well-ventilated areas. Exhaust gases contain carbon monoxide, which is lethal if inhaled.
- Do not leave a running machine unattended.
- Before you leave the operating position, do the following:
  - Park the machine on a level surface.
  - Lower the cutting units to the ground and ensure that they are disengaged.

- Engage the parking brake.
- Shut off the engine and remove the key.
- Wait for all movement to stop.

- Operate the machine only in good visibility and appropriate weather conditions. Do not operate the machine when there is the risk of lightning.

### **Rollover Protection System (ROPS) Safety**

- Do not remove any of the ROPS components from the machine.
- Ensure that the seat belt is attached and that you can release it quickly in an emergency.
- Always wear your seat belt.
- Check carefully for overhead obstructions and do not contact them.
- Keep the ROPS in safe operating condition by thoroughly inspecting it periodically for damage and keeping all the mounting fasteners tight.
- Replace all damaged ROPS components. Do not repair or alter them.

### **Slope Safety**

- Slopes are a major factor related to loss of control and rollover accidents, which can result in severe injury or death. You are responsible for safe slope operation. Operating the machine on any slope requires extra caution.
- Evaluate the site conditions to determine if the slope is safe for machine operation, including surveying the site. Always use common sense and good judgment when performing this survey.
- Review the slope instructions, listed below, for operating the machine on slopes. Before you operate the machine, review the site conditions to determine whether you can operate the machine in the conditions on that day and at that site. Changes in the terrain can result in a change in slope operation for the machine.
- Avoid starting, stopping, or turning the machine on slopes. Avoid making sudden changes in speed or direction. Make turns slowly and gradually.
- Do not operate a machine under any conditions where traction, steering, or stability is in question.
- Remove or mark obstructions such as ditches, holes, ruts, bumps, rocks, or other hidden hazards. Tall grass can hide obstructions. Uneven terrain could overturn the machine.
- Be aware that operating the machine on wet grass, across slopes, or downhill may cause the machine to lose traction. Loss of traction to the drive wheels may result in sliding and a loss of braking and steering.

- Use extreme caution when operating the machine near drop-offs, ditches, embankments, water hazards, or other hazards. The machine could suddenly roll over if a wheel goes over the edge or the edge caves in. Establish a safety area between the machine and any hazard.
- Identify hazards at the base of the slope. If there are hazards, mow the slope with a pedestrian-controlled machine.
- If possible, keep the cutting units lowered to the ground while operating on slopes. Raising the cutting units while operating on slopes can cause the machine to become unstable.
- Use extreme caution with grass-collection systems or other attachments. These can change the stability of the machine and cause a loss of control.

## Breaking in the Machine

Refer to the engine *Owner's Manual* supplied with the machine for oil change and maintenance procedures recommended during the break-in period.

Only 8 hours of operation is required for the break-in period.

Since the first hours of operation are critical to future dependability of the machine, monitor its functions and performance closely so that minor difficulties, which could lead to major problems, are noted and can be corrected. Inspect the machine frequently during break-in for signs of oil leakage, loose fasteners, or any other malfunction.

## Starting the Engine

**Important:** Do not use ether or other types of starting fluid.

**Note:** You may need to bleed the fuel system before starting the engine if any of the following situations have occurred:

- Initial start up of a new engine
- The engine has ceased running due to lack of fuel.
- Maintenance has been performed upon fuel system components; ie. filter replaced, etc.

Refer to your engine owner's manual.

1. Sit on the seat, lock the parking brake, disengage the raise/lower mow control and move the functional-control lever to the NEUTRAL position.
2. Remove your foot from the traction pedal and make sure the pedal is in the NEUTRAL position.
3. Move the throttle lever to the SLOW position.
4. Insert the key into the switch and rotate it to the ON position. Hold it in the ON position until the

glow-plug-indicator light goes off (approximately 6 seconds).

5. Turn the ignition key to the START position.

**Important:** To prevent overheating of the starter motor, do not engage the starter longer than 10 seconds. After 10 seconds of continuous cranking, wait 60 seconds before engaging the starter motor again.

6. Release the key when the engine starts and allow it to move to the ON position.
7. Allow the engine to warm up for a few minutes before operating.

**Important:** When starting the engine for the first time or after an overhaul of the engine, operate the machine in forward and reverse for 1 to 2 minutes. Turn the steering wheel to the left and right to check the steering response. Then shut the engine off and wait for all moving parts to stop; refer to [Shutting Off the Engine \(page 26\)](#). Check for oil leaks, loose parts and any other noticeable malfunctions.

## Checking the Machine after Starting the Engine

1. Move the throttle lever to the FAST position.
2. Move the raise/lower mow control lever forward momentarily.

The cutting units should lower and all the reels should rotate.

**Note:** The function lever should be in the middle (mow) position for the reels run when lowering the cutting units

3. Move the raise/lower mow control lever rearward.

The cutting reels should stop rotating and the cutting units should raise to the full transport position.

4. Engage the brake to keep the machine from moving, and operate the traction pedal through the forward and reverse positions.
5. Continue the above procedure for 1 or 2 minutes. Move the functional-control lever to the NEUTRAL position, engage the parking brake, and shut off the engine.
6. Check for fluid leaks and tighten the hydraulic fittings if any leaks are found.

**Note:** When the machine is new and the bearings and reels are tight, it is necessary to use the FAST throttle-lever position for this

check. A fast throttle setting may not be required after the break-in period.

**Note:** If fluid leaks continue to appear, contact your authorized Toro distributor for assistance and, if necessary, replacement parts.

**Important:** A trace of fluid on the motor or wheel seals is normal. Seals require a small amount of lubrication to perform properly.

## Shutting Off the Engine

1. Move the throttle lever to the SLOW position, pull back the raise/lower mow control, and move the functional-control lever to the NEUTRAL position.
2. Rotate the ignition key to the OFF position to shut off the engine. Remove the key from the switch to prevent accidental starting.
3. Close the fuel-shutoff valve before storing the machine.

## Checking the Safety-Interlock System

**Service Interval:** Before each use or daily

### **⚠ CAUTION**

**If the safety interlock switches are disconnected or damaged the machine could operate unexpectedly, causing personal injury.**

- **Do not tamper with the interlock switches.**
- **Check the operation of the interlock switches daily and replace any damaged switches before operating the machine.**

The purpose of the safety-interlock system is to prevent operation of the machine where there is possible injury to you or damage to the machine.

The safety-interlock system prevents the engine from starting unless:

- The traction pedal is in the NEUTRAL position.
- The functional-control lever is in the NEUTRAL position.

The safety-interlock system prevents the machine from moving unless:

- The parking brake is disengaged.
- You are seated in the operator's seat.
- The functional-control lever is in the MOW position or the TRANSPORT position.

The safety-interlock system prevents the reels from operating unless the functional-control lever is in the Mow position.

## Checking the Traction Pedal

Perform the following system checks daily to ensure that the interlock system is operating correctly:

1. Sit on the seat, move the traction pedal to the NEUTRAL position, move the functional-control lever to the NEUTRAL position, and engage the parking brake.
2. Try to move the traction pedal forward or backward.

The pedal should not move, which indicates that the interlock system is operating correctly. Correct the problem if it is not operating properly.

## Checking the Function Control

1. Sit on the seat, move the traction pedal to the NEUTRAL position, move the functional-control lever to the NEUTRAL position, and engage the parking brake.
2. Move the functional-control lever to the MOW position or the TRANSPORT position and try to start the engine.

The engine should not turnover or start, which indicates that the interlock system is operating correctly. Correct the problem if it is not operating properly.

3. Sit on the seat, move the traction pedal to the NEUTRAL position, move the functional-control lever to the NEUTRAL position, and engage the parking brake.
4. Start the engine and move the functional-control lever to the MOW position or the TRANSPORT position.

The engine should shut off, which indicates that the interlock system is operating correctly.

Correct the problem if it is not operating properly.

## Checking the Operator's Presence Switch

1. Sit on the seat, move the traction pedal to the NEUTRAL position, move the functional control lever to the NEUTRAL position, and engage the parking brake.
2. Start the engine.
3. Release the parking brake, move the functional control lever to the MOW position, and rise from the seat.

The engine should shut off, which indicates that the interlock system is operating correctly. Correct the problem if it is not operating properly.

## Checking the Raise/Lower Mow Control

1. Sit on the seat, move the traction pedal to the NEUTRAL position, move the functional control lever to the NEUTRAL position, and engage the parking brake.
2. Start the engine.
3. Move the raise/lower mow control forward to lower the cutting units. The cutting units should lower but not start rotating.

If they start rotating, the interlock system is not operating correctly; correct the problem before operating the machine.

## Driving the Machine without Mowing

- Ensure that the cutting units are fully raised.
- Move the functional-control lever to the TRANSPORT position.
- Use the brakes to slow the machine while going down steep hills to avoid loss of control.
- Always approach rough areas at a reduced speed and cross severe undulations carefully.
- Familiarize yourself with the width of the machine. Do not attempt to pass between objects that are close together to prevent costly damage and downtime.

## Mowing the Green

**Important:** If the leak detector alarm (if equipped on your model) sounds or you notice an oil leak while cutting on a green, immediately raise the cutting units, drive directly off the green, and stop the machine in an area away from the green. Determine the cause of the leak and correct the problem.

Before mowing greens, find a clear area and practice performing basic machine functions (e.g., starting and stopping the machine, raising and lowering the cutting units, and turning).

Inspect the green for debris, remove the flag from the cup, and determine the best direction to mow. Base the direction to mow on the previous mowing direction. Always mow in an alternate pattern from the previous mowing so that the grass blades are less apt to lay down and therefore be difficult to trap between the reel blades and the bedknife.

## Cutting the Green

1. Approach the green with the functional-control lever in the MOW position and the throttle at full speed.
2. Start on 1 edge of the green so that you can use the ribbon procedure of cutting.

**Note:** This holds compaction to a minimum and leaves a neat, attractive pattern on the greens.

3. Push forward the raise/lower mow lever as the front edges of the grass baskets cross the outer edge of the green.

**Note:** This procedure drops the cutting units to the turf and starts the reels.

**Important:** The center cutting unit drops and raises slightly after the front cutting units do; therefore, you should practice gaining the required timing necessary to minimize the cleanup mowing operation.

**Note:** The delay in raising and lowering the center cutting unit depends on hydraulic fluid temperature. Cold hydraulic fluid results in a longer delay. As the fluid temperature increases, the delay time becomes shorter.

4. Overlap a minimal amount with the previous cut on return passes.

**Note:** To assist in maintaining a straight line across the green and keeping the machine an equal distance from the edge of the previous cut, imagine a sight line approximately 1.8 to 3 m (6 to 10 ft) ahead of the machine to the edge of the uncut portion of the green (Figure 28). Include the outer edge of the steering wheel as part of the sight line; i.e., keep the steering wheel edge aligned with a point that is always kept the same distance away from the front of the machine.

5. As the front edges of the baskets cross the edge of the green, pull back the raise/lower mow lever rearward and hold it until all the cutting units have risen. This stops the reels and lifts the cutting units.

**Important:** Time this step correctly so that you do not cut into the fringe area, yet cut as much of the green as possible to minimize the amount of grass left to mow around the outer periphery.

6. To cut down on operating time and to ease the lineup for the next pass, momentarily turn the machine in the opposite direction, then turn it in the direction of the uncut portion. This movement is a tear-shaped turn (Figure 27), which quickly lines the machine up for your next pass.

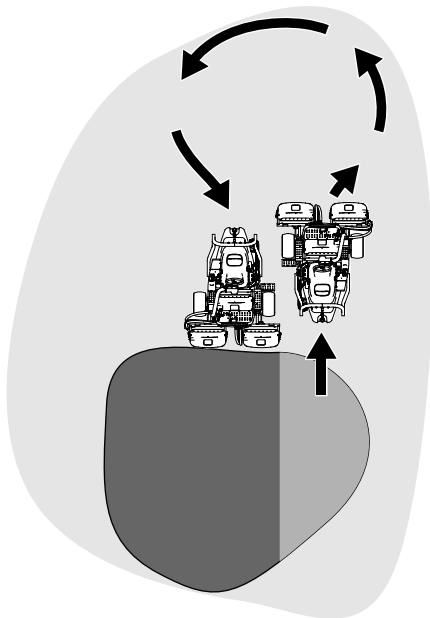

Figure 27

g229671

**Note:** Try to make as short of a turn as possible, except during warmer weather—a wider arc minimizes the turf bruising.

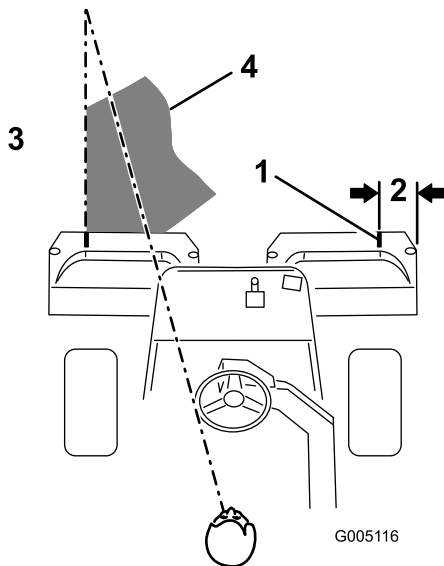

Figure 28

g005116

1. Alignment strip
2. Approximately 12.7 cm (5 inches)
3. Cut grass on the left.
4. Keep a focal spot 2 to 3 m (6 to 10 ft) ahead of the machine.

**Note:** The steering wheel does not return to its original position after you complete a turn.

**Important:** Never stop the machine on a green while the cutting units are engaged, as damage to the turf may result. Stopping the machine on a wet green may leave marks or indentations from the wheels.

## Cutting the Periphery and Finishing the Job

1. Finish cutting the green by mowing the outer periphery. Change the direction of cutting from the previous mowing.

**Note:** Use the throttle lever to adjust the machine speed when you cut the periphery. This will match the clip to the green and may reduce triplex ring.

**Note:** Always keep weather and turf conditions in mind and be sure to change the direction of mowing from the previous cutting.

2. When finished mowing the outer periphery, tap the raise/lower mow lever rearward to stop the reels, then drive off the green. When all the cutting units are off the green, raise the cutting units.

**Note:** This step minimizes grass clumps left on the green.

3. Replace the flag.
4. Empty the grass baskets of all clippings before you transport the machine to the next green.

**Note:** Heavy wet clippings place an undue strain on the baskets and add unnecessary weight to the machine, which increases the load on the machine systems (e.g., engine, hydraulic system, and brakes).

# After Operation

## After Operation Safety

### General Safety

- Engage the parking brake, shut off the engine, remove the key, and wait for all movement to stop before you leave the operator's position. Allow the machine to cool before adjusting, servicing, cleaning, or storing it.
- Clean grass and debris from the cutting units and drives to help prevent fires. Clean up oil or fuel spills.
- Shut off the fuel while storing or hauling the machine.
- Disengage the drive to the attachment whenever you are hauling or not using the machine.
- Allow the machine to cool before storing the machine in any enclosure.
- Maintain and clean the seat belt(s) as necessary.
- Do not store the machine or fuel container where there is an open flame, spark, or pilot light, such as on a water heater or on other appliances.

### Towing Safety

- Tow only with a machine that has a hitch designed for towing. Do not attach towed equipment except at the hitch point.
- Follow the manufacturer's recommendation for weight limits for towed equipment and towing on slopes. On slopes, the weight of the towed equipment may cause loss of traction and loss of control.
- Never allow children or others in or on towed equipment.
- Travel slowly and allow extra distance to stop when towing.

## Inspecting and Cleaning after Mowing

After mowing, thoroughly wash the machine with a garden hose without a nozzle so that excessive water pressure does not contaminate and damage the seals and bearings. **Do not wash a warm engine or the electrical connections with water.**

***Important:*** Do not use brackish or reclaimed water to clean the machine.

***Important:*** Do not use power-washing equipment to wash the machine. Power-washing equipment may damage the electrical system, loosen important decals, or wash away necessary grease at friction points. Avoid excessive use of water near the control panel, engine, and battery.

***Important:*** Do not wash the machine with the engine running. Washing the machine with the engine running may result in internal engine damage.

After cleaning the machine, do the following:

- Inspect the machine for possible hydraulic fluid leaks, damage or wear to hydraulic and mechanical components.
- Inspect the cutting units for sharpness.
- Lubricate the brake-shaft assembly with SAE 30 oil or spray lubricant to deter corrosion and help keep the machine performing satisfactorily during the next mowing operation.

## Hauling the Machine

- Use care when loading or unloading the machine into a trailer or a truck.
- Use a full-width ramp for loading the machine into a trailer or a truck.
- Tie the machine down securely using straps, chains, cable, or ropes. Both front and rear straps should be directed down and outward from the machine (Figure 29).

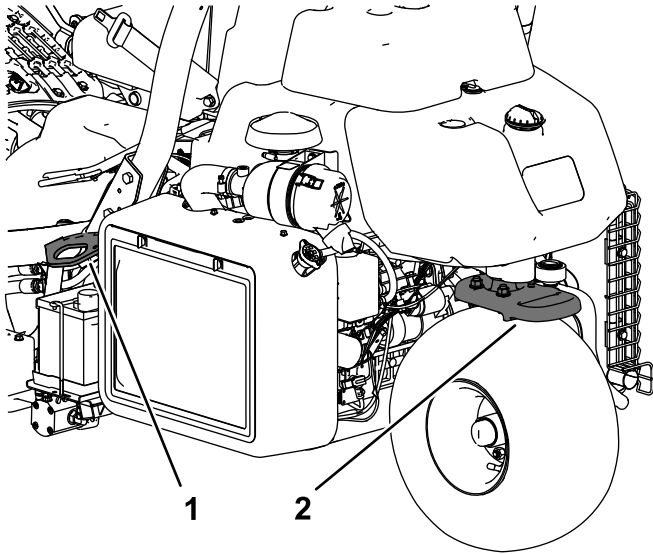

Figure 29

g270390

1. Tie-down loop (each side) 2. Rear tie-down loop

## Towing the Machine

In case of an emergency, you can tow the machine for up to 0.4 km (1/4 mi).

**Important:** Do not tow the machine faster than 3 to 5 km/h (2 to 3 mph) to avoid damaging the drive system. If you must move the machine more than 0.4 km (1/4 mi), transport it on a truck or trailer.

1. Locate the bypass valve on the pump (Figure 30).

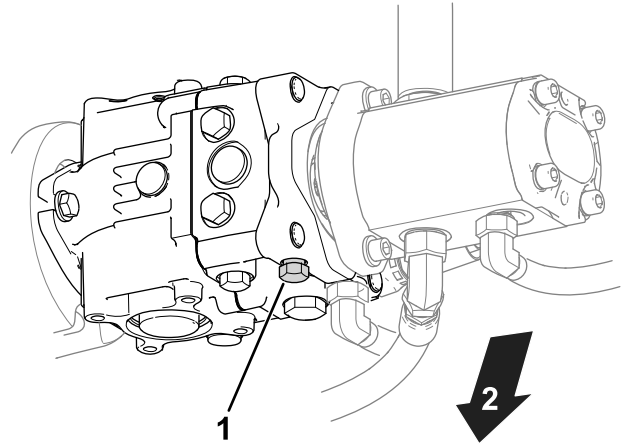

Figure 30

g400870

1. Bypass valve 2. Bottom of the machine

2. Open the bypass valve by turning the valve 3 revolutions counterclockwise.
3. Before starting the engine, tighten the bypass valve and torque the valve to 12 N·m (9 ft-lb).

**Important:** Do not start the engine when the bypass valve is open.

# Maintenance

## **⚠ CAUTION**

Failure to properly maintain the machine could result in premature failure of machine systems causing possible harm to you or bystanders.

Keep the machine well maintained and in good working order as indicated in these instructions.

**Note:** Determine the left and right sides of the machine from the normal operating position.

**Note:** Download a free copy of the electrical or hydraulic schematic by visiting [www.Toro.com](http://www.Toro.com) and searching for your machine from the Manuals link on the home page.

**Important:** Refer to your engine owner's manual for additional maintenance procedures.

## **⚠ WARNING**

If you leave the key in the ignition switch, someone could accidentally start the engine and seriously injure you or other bystanders.

Remove the key from the ignition and disconnect the wires from the spark plugs before you do any maintenance. Set the wires aside so that they do not accidentally contact the spark plugs.

## Maintenance Safety

- Before you leave the operator's position, do the following:
  - Park the machine on a level surface.
  - Disengage the cutting unit(s).
  - Engage the parking brake.
  - Shut off the engine and remove the key.
  - Wait for all movement to stop.
- Allow machine components to cool before performing maintenance.
- If possible, do not perform maintenance while the engine is running. Keep away from moving parts.
- Support the machine with jack stands whenever you work under the machine.
- Carefully release pressure from components with stored energy.
- Keep all parts of the machine in good working condition and all hardware tightened.
- Replace all worn or damaged decals.
- To ensure safe, optimal performance of the machine, use only genuine Toro replacement parts. Replacement parts made by other manufacturers could be dangerous, and such use could void the product warranty.

# Recommended Maintenance Schedule(s)

Maintenance Service Interval	Maintenance Procedure
After the first hour	<ul style="list-style-type: none"> <li>• Torque the wheel hub nuts.</li> <li>• Torque the wheel nuts.</li> </ul>
After the first 8 hours	<ul style="list-style-type: none"> <li>• Check the tension on the alternator belt.</li> </ul>
After the first 10 hours	<ul style="list-style-type: none"> <li>• Torque the wheel hub nuts.</li> <li>• Torque the wheel nuts.</li> </ul>
After the first 50 hours	<ul style="list-style-type: none"> <li>• Change the engine oil and filter.</li> <li>• Check the engine speed (at idle and full throttle).</li> </ul>
Before each use or daily	<ul style="list-style-type: none"> <li>• Inspect the seat belt(s) for wear, cuts, and other damage. Replace the seat belt(s) if any component does not operate properly.</li> <li>• Check the safety-interlock system</li> <li>• Check the safety-interlock system.</li> <li>• Inspect and cleanup after mowing.</li> <li>• Check the engine oil.</li> <li>• Drain water from the fuel filter.</li> <li>• Check the tire pressure.</li> <li>• Clean the radiator screen. Clean it hourly if conditions are extremely dusty and dirty.</li> <li>• Check the engine-coolant level.</li> <li>• Check the hydraulic-fluid level.</li> <li>• Check the hydraulic lines and hoses.</li> <li>• Check the reel-to-bedknife contact.</li> </ul>
Every 50 hours	<ul style="list-style-type: none"> <li>• Check the battery cable connections.</li> </ul>
Every 100 hours	<ul style="list-style-type: none"> <li>• Change the engine oil and filter.</li> </ul>
Every 200 hours	<ul style="list-style-type: none"> <li>• Service the air-cleaner filter (more frequently when operating conditions are dusty or dirty).</li> <li>• Torque the wheel hub nuts.</li> <li>• Torque the wheel nuts.</li> </ul>
Every 500 hours	<ul style="list-style-type: none"> <li>• Replace the fuel filter.</li> </ul>
Every 800 hours	<ul style="list-style-type: none"> <li>• If you are not using the recommended hydraulic fluid or have ever filled the reservoir with an alternative fluid, change the hydraulic fluid, filter, and tank breather.</li> <li>• Check the engine speed (at idle and full throttle).</li> <li>• Check the valve clearance.</li> </ul>
Every 1,000 hours	<ul style="list-style-type: none"> <li>• If you are using the recommended hydraulic fluid, change the hydraulic-fluid filter.</li> </ul>
Every 2,000 hours	<ul style="list-style-type: none"> <li>• If you are using the recommended hydraulic fluid, change the hydraulic fluid.</li> </ul>
Yearly	<ul style="list-style-type: none"> <li>• Burnish the brakes.</li> </ul>
Every 2 years	<ul style="list-style-type: none"> <li>• Check the fuel lines and connections.</li> <li>• Replace moving hoses.</li> <li>• Drain and flush the cooling system.</li> </ul>

# Daily Maintenance Checklist

Duplicate this page for routine use.

Maintenance Check Item	For the week of:						
	Mon.	Tues.	Wed.	Thurs.	Fri.	Sat.	Sun.
Check the safety-interlock operation.							
Check the instrument operation.							
Check the brake operation.							
Check/empty the fuel filter/water separator.							
Check the fuel level.							
Check the hydraulic-fluid level.							
Check the engine-oil level.							
Clean the screen and radiator.							
Inspect the air filter.							
Check any unusual engine noises.							
Check the reel-to-bedknife adjustment.							
Check the hydraulic hoses for damage.							
Check for fluid leaks.							
Check the tire pressure.							
Check the height-of-cut adjustment.							
Touch-up damaged paint.							

## Notation for Areas of Concern

Inspection performed by:		
Item	Date	Information

# Engine Maintenance

## Engine Safety

- Shut off the engine before checking the oil or adding oil to the crankcase.
- Do not change the governor speed or overspeed the engine.

## Servicing the Air Cleaner

**Service Interval:** Every 200 hours—Service the air-cleaner filter (more frequently when operating conditions are dusty or dirty).

- Check the air-cleaner body for damage which could cause an air leak; replace it if it is damaged. Check the whole intake system for leaks, damage, or loose hose clamps.
  - Changing the air filter before it is necessary increases the chance of dirt entering the engine when the filter is removed.
  - Ensure that the cover is seated correctly and seals with the air cleaner body.
1. Release the latches securing the air-cleaner cover to the air-cleaner body (Figure 31).

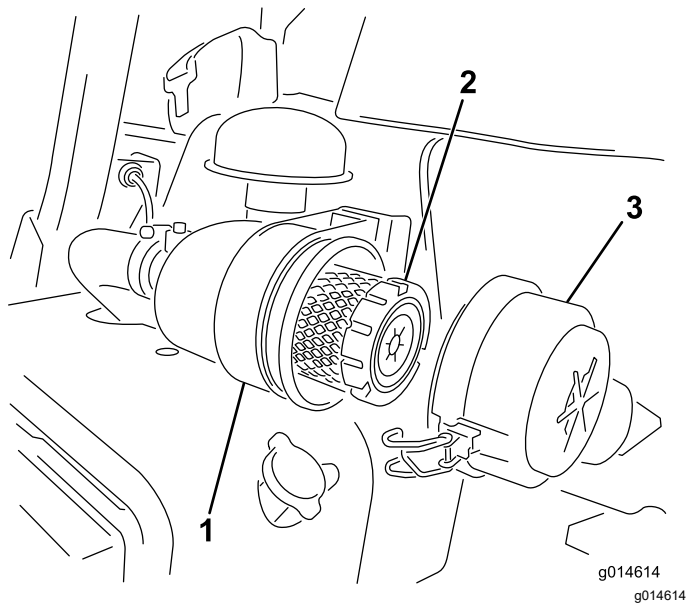

Figure 31

- |                     |                      |
|---------------------|----------------------|
| 1. Air-cleaner body | 3. Air-cleaner cover |
| 2. Air filter       |                      |

2. Remove the cover from the air-cleaner body.
3. Before removing the filter, use low pressure air (275 kPa (40 psi), clean and dry) to help remove large accumulations of debris packed between the outside of the primary filter and the canister. This cleaning process prevents debris getting

into the intake when you remove the primary filter.

**Important:** Avoid using high-pressure air that could force dirt through the filter into the intake tract.

4. Remove and replace the primary filter, as follows:

**Important:** Do not clean the used element.

- A. Inspect the new filter for shipping damage; do not use a damaged element.
- B. Carefully pull the old filter out of the filter body and discard it.
- C. Insert the new filter by applying pressure to the outer rim of the element to seat it in the canister, checking the sealing end of the filter and the body.

**Important:** Do not apply pressure to the flexible center of the filter.

5. Clean the dirt ejection port located in the removable cover. Remove the rubber outlet valve from the cover, clean the cavity and replace the outlet valve.
6. Install the cover orienting the rubber outlet valve in a downward position—between approximately 5 o'clock to 7 o'clock when viewed from the end.
7. Secure the latches (Figure 31).

## Servicing the Engine Oil

### Checking the Engine Oil

**Service Interval:** Before each use or daily

The engine is shipped with 3.7 L (3.9 US qt) (with filter) of oil in the crankcase; however, you must check the oil level before and after starting the engine the first time.

Use high-quality engine oil that meets the following specifications:

- API Classification Level Required: CH-4, CI-4 or higher.
- Preferred oil: SAE 10W-30
- Alternate oil: SAE 15W-40

Toro Premium Engine oil is available from your distributor in the 10W-30 viscosity. See the *Parts Catalog* for part numbers.

**Note:** The best time to check the engine oil is when the engine is cool before it has been started for the day. If it has already been run, allow the oil to drain back down to the sump for at least 10 minutes before

checking. If the oil level is at or below the Add mark on the dipstick, add oil to bring the oil level to the FULL mark. **Do not overfill.**

**Important:** Keep the engine oil level between the upper and lower limits on the oil gauge; the engine may fail if you run it with too much or too little oil.

1. Position the machine on a level surface.
2. Remove the dipstick and wipe it with a clean rag (Figure 33).

**Important:** Remove the dipstick while filling the engine with oil. When adding engine oil or filling oil, there *must be* clearance between the oil fill device and the oil fill hole in the valve cover as shown in Figure 32. This clearance is necessary to permit venting when filling, which prevents the oil from overrunning into the breather.

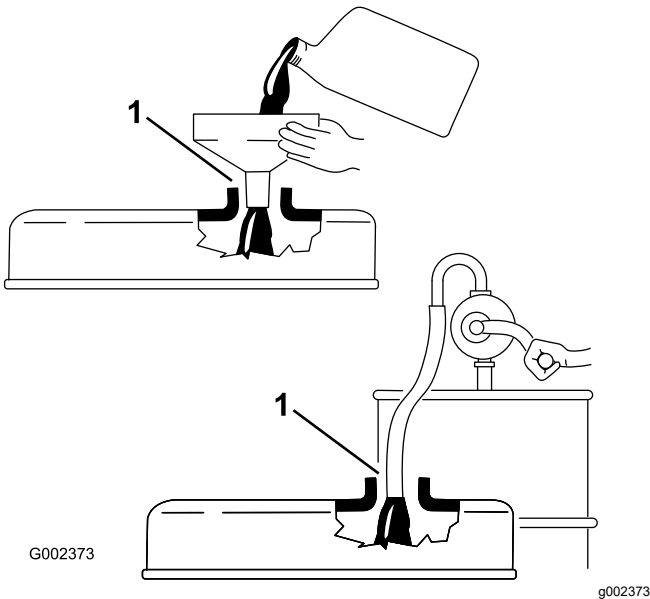

Figure 32

1. Note clearance

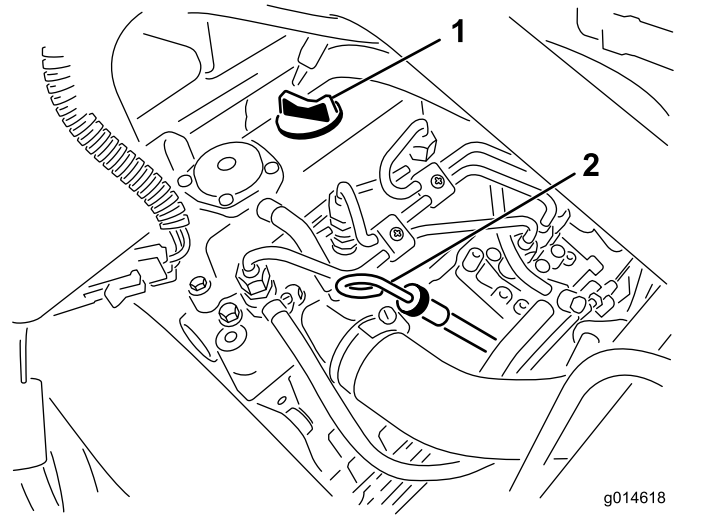

Figure 33

1. Filler cap
2. Dipstick

3. Push the dipstick into the tube and make sure it is seated fully.
4. Remove the dipstick from the tube and check the oil level

**Note:** If the oil level is low, remove the filler cap from the valve cover and **slowly** add enough oil to raise the level to the FULL mark on the dipstick.

Add the oil slowly and check the level often during this process. **Do not overfill.**

5. Replace the dipstick.
6. Start and run the engine at idle for 30 seconds, then shut the engine off. Wait 30 seconds, then repeat steps 2 through 5.
7. Install the filler cap and dipstick firmly in place.

## Changing the Engine Oil and Filter

**Service Interval:** After the first 50 hours

Every 100 hours

1. Remove the drain plug and let oil flow into a drain pan. When the oil stops, install the drain plug (Figure 34).

# Fuel System Maintenance

## Draining Water from the Fuel Filter

**Service Interval:** Before each use or daily

1. Park the machine on a level surface and shut off the engine.
2. Place a drain pan under the fuel filter.
3. Open the drain plug on the fuel filter approximately one turn and drain any accumulated water (Figure 36).

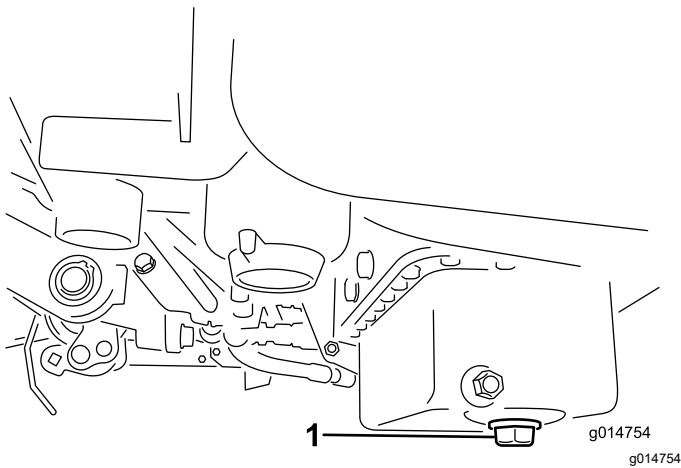

Figure 34

1. Drain plug

2. Remove the oil filter (Figure 35). Apply a light coat of clean oil to the new filter gasket.

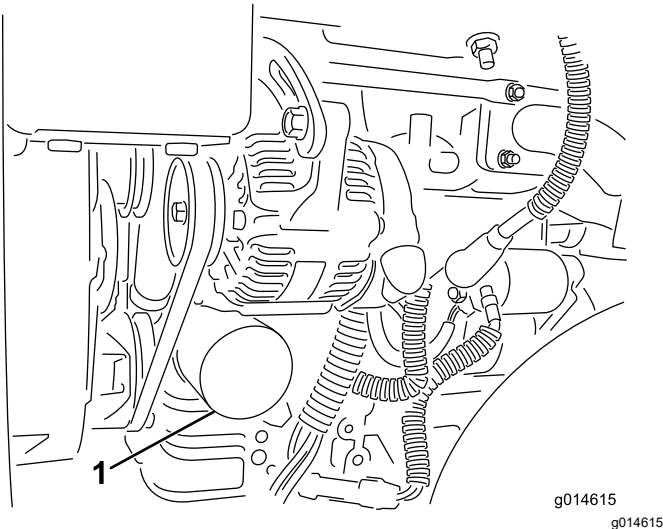

Figure 35

1. Oil filter

3. Screw the filter on by hand until the gasket contacts the filter adapter, then tighten 1/2 to 3/4 turn further. **Do not overtighten.**
4. Add oil to the crankcase; refer to [Checking the Engine Oil \(page 34\)](#).
5. Dispose of the used oil properly.

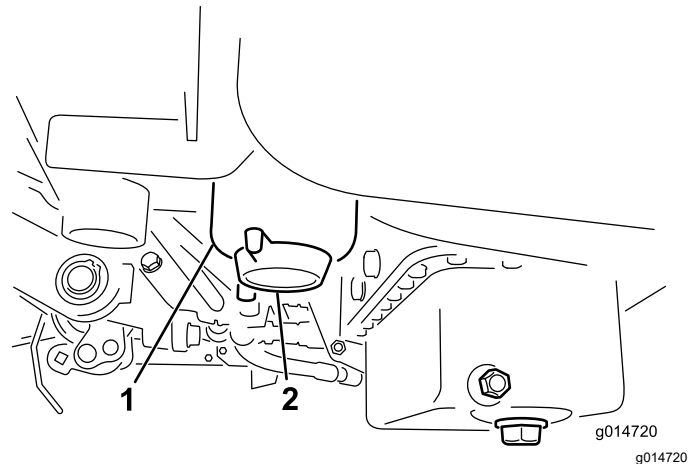

Figure 36

1. Fuel filter
2. Drain plug

4. Tighten the plug after draining.

**Note:** Because the accumulated water will be mixed with diesel fuel, drain the fuel filter into a suitable container and dispose of it properly.

# Replacing the Fuel Filter/Water Separator

**Service Interval:** Every 500 hours

1. Close the fuel-shutoff valve (Figure 37) below the fuel tank.

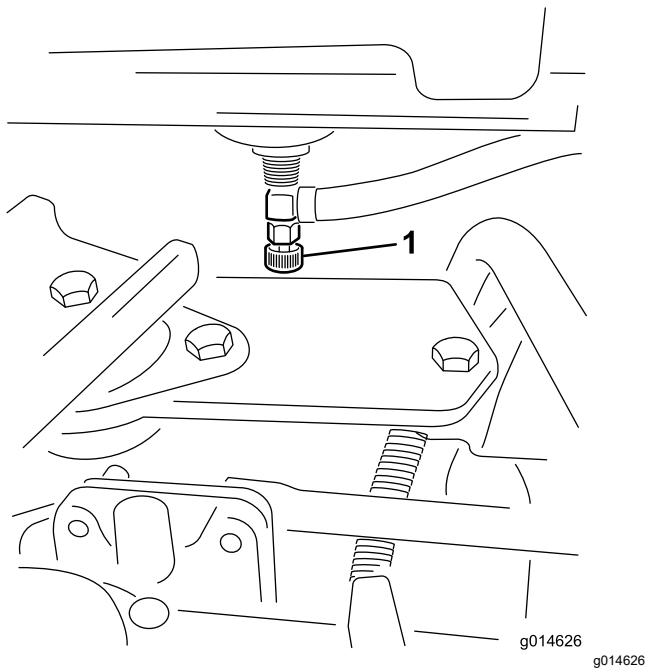

**Figure 37**

1. Fuel-shutoff valve

- 
2. Clean the area where the filter canister mounts (Figure 38).
  3. Place a drain pan under the fuel filter.
  4. Open the filter drain plug (Figure 38).

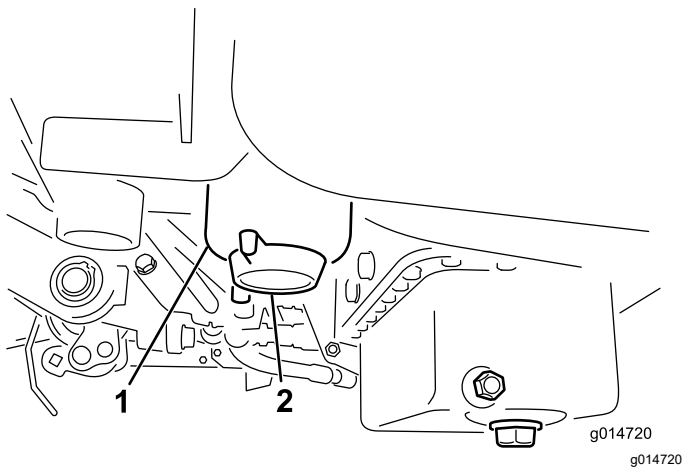

**Figure 38**

1. Fuel filter/water separator
2. Filter-drain plug canister

- 
5. Unscrew the filter canister and dispose of it according to local regulations.

6. Screw the filter on by hand until the gasket contacts the filter adapter, then tighten 1/2 to 3/4 turn further.
7. Ensure that the filter-drain plug is closed. Open the fuel-shutoff valve.

## Inspecting the Fuel Lines and Connections

**Service Interval:** Every 2 years

Inspect the fuel lines for deterioration, damage, or loose connections.

# Electrical System Maintenance

## Electrical System Safety

- Disconnect the battery before repairing the machine. Disconnect the negative terminal first and the positive last. Connect the positive terminal first and the negative last.
- Charge the battery in an open, well-ventilated area, away from sparks and flames. Unplug the charger before connecting or disconnecting the battery. Wear protective clothing and use insulated tools.

## Disconnecting the Battery

### ⚠ WARNING

Battery terminals or metal tools could short against metal components, causing sparks. Sparks can cause the battery gasses to explode, resulting in personal injury.

- When removing or installing the battery, do not allow the battery terminals to touch any metal parts of the machine.
- Do not allow metal tools to short between the battery terminals and metal parts of the machine.

### ⚠ WARNING

Incorrect battery cable routing could damage the machine and cables causing sparks. Sparks can cause the battery gasses to explode, resulting in personal injury.

Always disconnect the negative (black) battery cable before disconnecting the positive (red) cable.

1. Remove the negative battery cable from the battery post (Figure 39).

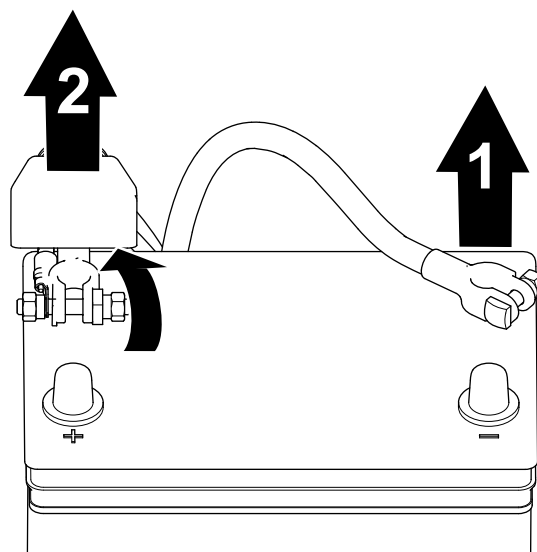

g253380

Figure 39

1. Negative battery cable
2. Positive battery cable

2. Lift the insulator and remove the positive battery cable from the battery post (Figure 39).

## Connecting the Battery

### ⚠ WARNING

Incorrect battery cable routing could damage the machine and cables causing sparks. Sparks can cause the battery gasses to explode, resulting in personal injury.

Always connect the positive (red) battery cable before connecting the negative (black) cable.

1. Connect the positive cable to the battery and tighten the battery-clamp nut (Figure 40).

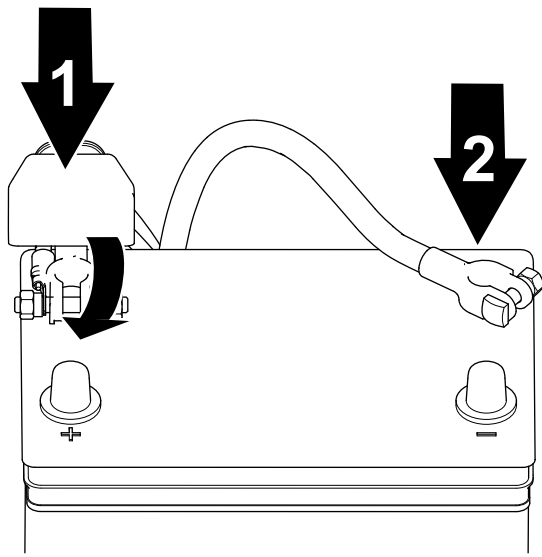

Figure 40

g253379

1. Positive battery cable
2. Negative battery cable

2. Connect the negative cable to the battery and tighten the battery-clamp nut (Figure 40).

## Charging the Battery

### ⚠ WARNING

Battery terminals or metal tools could short against metal machine components, causing sparks. Sparks can cause the battery gasses to explode, resulting in personal injury.

- When removing or installing the battery, do not allow the battery terminals to touch any metal parts of the machine.
- Do not allow metal tools to short between the battery terminals and metal parts of the machine.

1. Disconnect the battery; refer to [Disconnecting the Battery](#) (page 38).
2. Remove the fasteners that secure the battery to the tray (Figure 41) and lift out the battery.

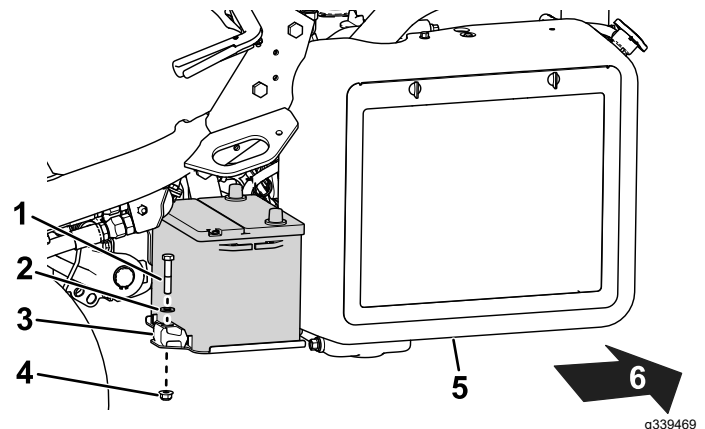

Figure 41

g339469

- |             |                        |
|-------------|------------------------|
| 1. Bolt     | 4. Nut                 |
| 2. Washer   | 5. Radiator            |
| 3. Retainer | 6. Rear of the machine |

3. Connect a 2 to 4 A battery charger to the battery posts. Charge the battery for at least 2 hours at 4 A or for at least 4 hours at 2 A until the specific gravity is 1.250 or higher and the temperature is at least 16°C (60°F) with all cells gassing freely.

### ⚠ WARNING

Charging the battery produces gasses that can explode.

Never smoke near the battery and keep sparks and flames away from the battery.

**Important:** If you do not charge the battery for at least the time specified above, you may reduce the life of the battery.

4. When the battery is charged, disconnect the charger from the electrical outlet and battery posts.
5. Place the battery on the battery tray and secure it with the previously removed fasteners (Figure 41).
6. Connect the battery; refer to [Connecting the Battery](#) (page 38).

## Locating the Fuses

The fuses in the electrical system are located under the seat (Figure 42).

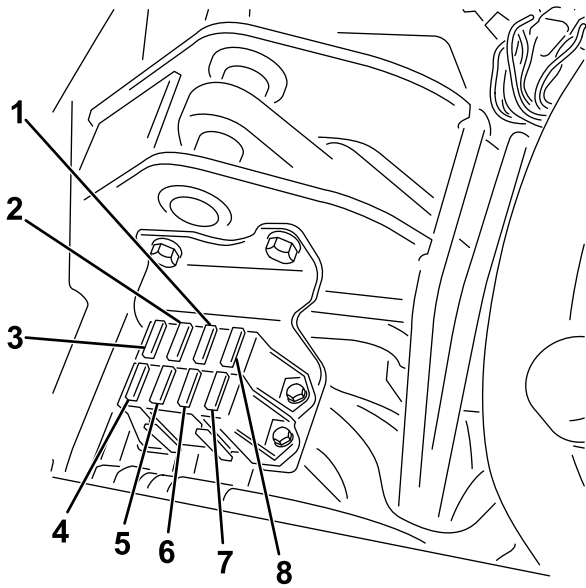

**Figure 42**

g195277

- |  |                                  |
|--|----------------------------------|
| 1. Start/run, Diagnostic lights, and glow—7.5 A  | 5. Lights and leak detector—15 A |
| 2. Reel engage, lift/lower, fan—7.5 A            | 6. Starter—15 A                  |
| 3. Lift reel, E-reel enable, and over temp—7.5 A | 7. Run—10 A                      |
| 4. No fuse                                       | 8. ECM logic and power—2 A       |

## Drive System Maintenance

### Checking the Tire Pressure

**Service Interval:** Before each use or daily

Vary the tire pressure for all 3 wheels, depending upon your turf conditions, from a minimum of 83 to a maximum of 110 kPa (12 psi to 16 psi).

### Checking the Torque of the Front Wheel Hub Nuts

**Service Interval:** After the first hour

After the first 10 hours

Every 200 hours

**Wheel hub nut torque specification:** 420 to 461 N·m (310 to 340 ft-lb)

### Checking the Torque of the Wheel Nuts

**Service Interval:** After the first hour

After the first 10 hours

Every 200 hours

#### **⚠ WARNING**

**Failure to maintain proper torque of the wheel nuts could result in personal injury.**

**Torque the wheel nuts to the specified torque at the specified intervals.**

**Wheel nut torque specification:** 95 to 122 N·m (70 to 90 ft-lb)

**Note:** To ensure even distribution, torque the wheel nuts in a X pattern.

### Adjusting the Transmission for Neutral

If the machine creeps when the traction-control pedal is in the NEUTRAL position, adjust the neutral-return mechanism.

1. Ensure that the bypass valve is closed.
2. Lift the machine and support it at the frame so that 1 of the front wheels is off the floor.

**Note:** If the machine is equipped with a 3-Wheel Drive Kit, also raise and block the rear wheel.

3. Start the engine, move the throttle to the SLOW position, and ensure that the front wheel that is off the floor is not rotating.
4. If the wheel is rotating, shut off the engine and proceed as follows:
  - A. Loosen the nut securing the eccentric to the top of the hydrostat (Figure 43).

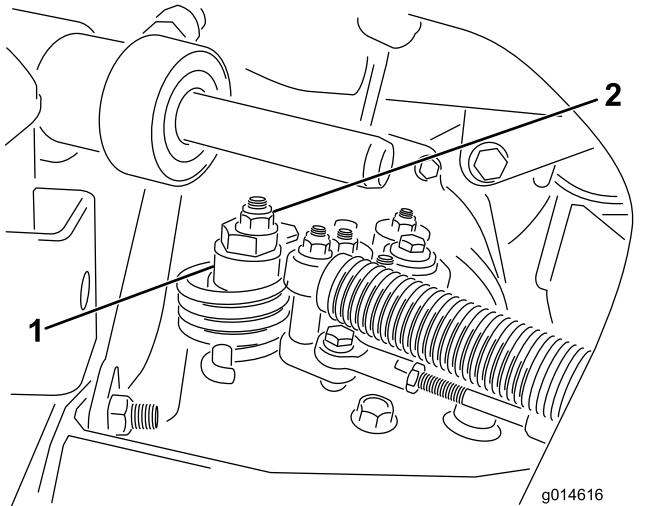

**Figure 43**

1. Eccentric
2. Locknut

- B. Move the functional-control lever to the NEUTRAL position and the throttle to the SLOW position. Start the engine.
- C. Rotate the eccentric until creep does not occur in either direction. When the wheel stops rotating, tighten the nut locking the eccentric and the adjustment (Figure 43). Verify the adjustment with the throttle in the SLOW and FAST position.

**Note:** If the wheel still turns when the eccentric is at the maximum adjustment, contact your authorized Toro distributor or refer to the *Service Manual* for further adjustment.

## Adjusting the Transport Speed

### Obtaining the Maximum Transport Speed

The traction pedal comes adjusted for maximum-transport speed, but you may need to adjust it if the pedal reaches full stroke before it contacts the pedal stop, or if you want to decrease the transport speed.

To obtain the maximum-transport speed, put the functional control lever in the TRANSPORT position and press down on the traction pedal. If the pedal contacts the stop (Figure 44) before you feel tension on the cable, perform the following adjustment procedure:

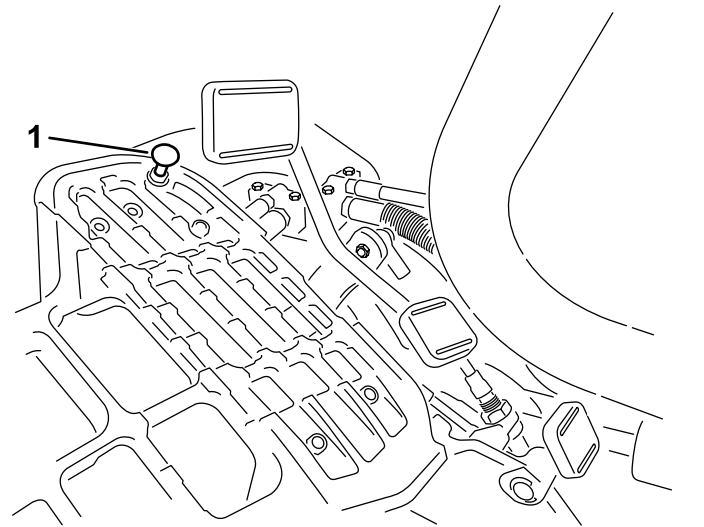

**Figure 44**

1. Pedal stop

1. Put the functional-control lever in the TRANSPORT position and loosen the locknut securing the pedal stop to the floor plate (Figure 44).
2. Tighten the pedal stop until it does not contact the traction pedal.
3. Continue applying a light load on the transport pedal and adjust the pedal stop so it contacts the pedal rod and tighten the nuts.

**Important:** Ensure that the tension on the cable is not excessive or you will reduce the cable life.

### Reducing the Transport Speed

1. Press down on the traction pedal and loosen the locknut securing the pedal stop to the floor plate.
2. Loosen the pedal stop until you obtain the desired transport speed.
3. Tighten the locknut securing the pedal stop.

# Adjusting the Mowing Speed

The mow speed is set to 3.8 mph at the factory.

You can adjust the forward moving speed from 0 to 8 km/h (0 to 5 mph).

1. Loosen the jam nut on the trunnion bolt (Figure 45).
2. Loosen the nut securing the lock and mow brackets on the pedal pivot.

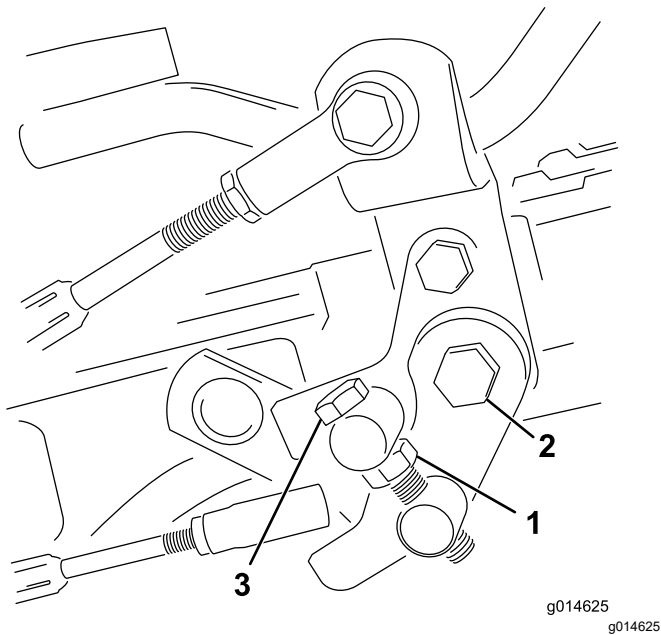

**Figure 45**

- |            |                  |
|------------|------------------|
| 1. Jam nut | 3. Trunnion bolt |
| 2. Nut     |                  |

3. Rotate the trunnion bolt clockwise to reduce the mowing speed and counterclockwise to increase the mowing speed.
4. Tighten the jam nut on the trunnion bolt and the nut on the pedal pivot to lock the adjustment (Figure 45). Check the adjustment and adjust as required.

# Cooling System Maintenance

## Cooling System Safety

- Swallowing engine coolant can cause poisoning; keep out of reach from children and pets.
- Discharge of hot, pressurized coolant or touching a hot radiator and surrounding parts can cause severe burns.
  - Always allow the engine to cool at least 15 minutes before removing the radiator cap.
  - Use a rag when opening the radiator cap, and open the cap slowly to allow steam to escape.

## Cleaning the Radiator Screen

**Service Interval:** Before each use or daily Clean it hourly if conditions are extremely dusty and dirty.

To prevent the system from overheating, keep the radiator screen and radiator clean. Check and clean the screen and radiator daily or, if necessary, hourly. Clean these components more frequently in dusty, dirty conditions.

1. Remove the radiator screen (Figure 46).

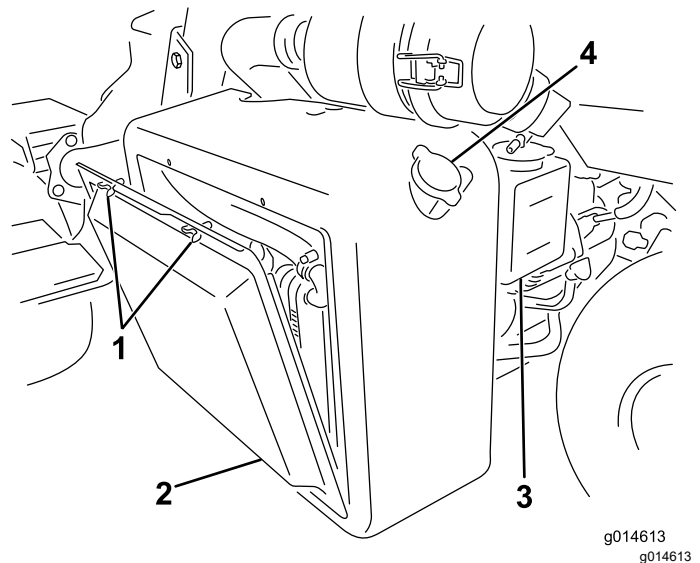

**Figure 46**

- |                    |                 |
|--------------------|-----------------|
| 1. Wing bolts      | 3. Reserve tank |
| 2. Radiator screen | 4. Radiator cap |

2. Working from the fan side of the radiator, blow out the radiator with compressed air.
3. Clean the screen and install it.

# Checking the Engine-Coolant Level

The capacity of the cooling system is approximately 4.6 L (4.9 US qt).

Fill the cooling system with a 50/50 solution of water and permanent ethylene glycol antifreeze. Check the level of the coolant at the beginning of each day before starting the engine.

## ⚠ CAUTION

If the engine has been running, the pressurized, hot coolant can escape and cause burns.

- Do not open the radiator cap when the engine is running.
- Use a rag when opening the radiator cap, and open the cap slowly to allow steam to escape.

1. Park the machine on a level surface.
2. Check the coolant level (Figure 46 and Figure 47).

It should be between the lines on the reserve tank when the engine is cold.

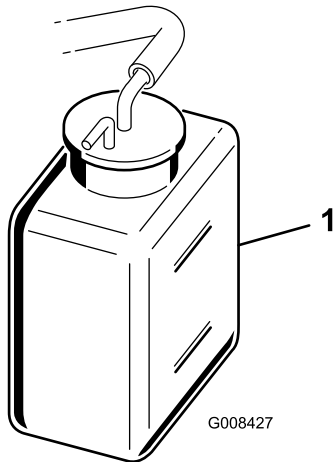

Figure 47

1. Reserve tank

3. If the coolant is low, remove the reserve tank cap and add a 50/50 mixture of water and permanent ethylene glycol antifreeze. **Do not overfill.**
4. Install the reserve-tank cap.

# Brake Maintenance

## Burnishing the Brakes

**Service Interval:** Yearly

Firmly apply the brakes and drive the machine at mowing speed until the brakes are hot, as indicated by their smell. You may need to adjust the brakes after the break-in period; refer to [Adjusting the Brakes \(page 43\)](#).

## Adjusting the Brakes

If the brake fails to hold the machine while parked, you can adjust the brakes using the bulkhead fitting near the brake drum; contact your Authorized Service Dealer or refer to the *Service Manual* for more information.

**Note:** Burnish the brakes annually; refer to [Burnishing the Brakes \(page 43\)](#).

# Belt Maintenance

## Adjusting the Alternator Belt

**Service Interval:** After the first 8 hours

Ensure that the belt is properly tensioned to ensure proper operation of the machine and prevent unnecessary wear.

1. Park the machine on a level surface, shut off the engine, engage the parking brake, remove the key, and wait for all moving parts to stop.
2. Apply moderate thumb pressure to the belt between the pulleys (10 kg or 22 lb). The belt should deflect 7 to 9 mm (0.28 to 0.35 inch). If not, complete the following procedure to adjust the belt tension:

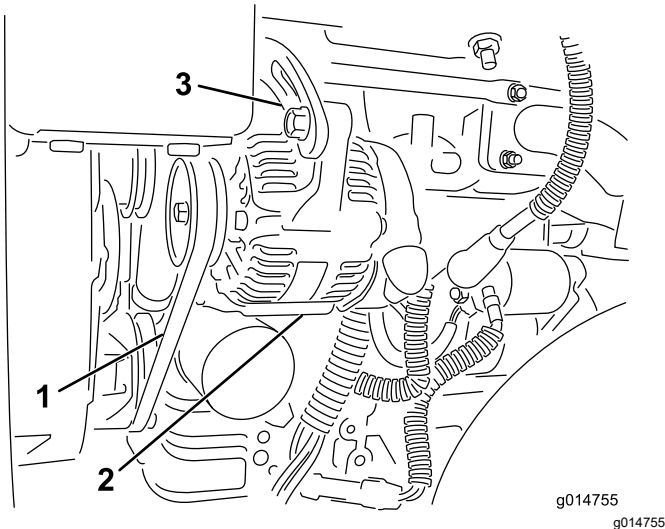

**Figure 48**

1. Alternator belt—apply pressure here
  2. Alternator
  3. Adjusting strap
- 
- A. Loosen the bolts securing the alternator to the engine and adjusting strap.
  - B. Inspect the belt for wear or damage and replace if it is worn.
  - C. Using a lever placed between the alternator and the engine block, pull the alternator out to obtain the correct belt tension and tighten the bolts.

# Hydraulic System Maintenance

## Hydraulic System Safety

- Seek immediate medical attention if fluid is injected into skin. Injected fluid must be surgically removed within a few hours by a doctor.
- Ensure that all hydraulic-fluid hoses and lines are in good condition and all hydraulic connections and fittings are tight before applying pressure to the hydraulic system.
- Keep your body and hands away from pinhole leaks or nozzles that eject high-pressure hydraulic fluid.
- Use cardboard or paper to find hydraulic leaks.
- Safely relieve all pressure in the hydraulic system before performing any work on the hydraulic system.

## Servicing the Hydraulic Fluid

**Important:** Regardless of the hydraulic fluid type used, any machine used for mowing fairways, verticutting, or used during ambient temperatures above 29°C (85°F) should have the Oil Cooler Kit (Part No. 117-9314) installed.

## Hydraulic Fluid Specifications

The reservoir is filled at the factory with high-quality hydraulic fluid. Check the level of the hydraulic fluid before you first start the engine and daily thereafter; refer to [Checking the Hydraulic-Fluid Level \(page 45\)](#).

**Recommended hydraulic fluid:** Toro PX Extended Life Hydraulic Fluid; available in 19 L (5 US gallon) pails or 208 L (55 US gallon) drums.

**Note:** A machine using the recommended replacement fluid requires less frequent fluid and filter changes.

**Alternative hydraulic fluids:** If Toro PX Extended Life Hydraulic Fluid is not available, you may use another conventional, petroleum-based hydraulic fluid having specifications that fall within the listed range for all the following material properties and that it meets industry standards. Do not use synthetic fluid. Consult with your lubricant distributor to identify a satisfactory product.

**Note:** Toro does not assume responsibility for damage caused by improper substitutions, so use products only from reputable manufacturers who will stand behind their recommendation.

## High Viscosity Index/Low Pour Point Anti-wear Hydraulic Fluid, ISO VG 46

### Material Properties:

Viscosity, ASTM D445	cSt @ 40°C (104°F) 44 to 48
Viscosity Index ASTM D2270	140 or higher
Pour Point, ASTM D97	-37°C to -45°C (-34°F to -49°F)
Industry Specifications:	Eaton Vickers 694 (I-286-S, M-2950-S/35VQ25 or M-2952-S)

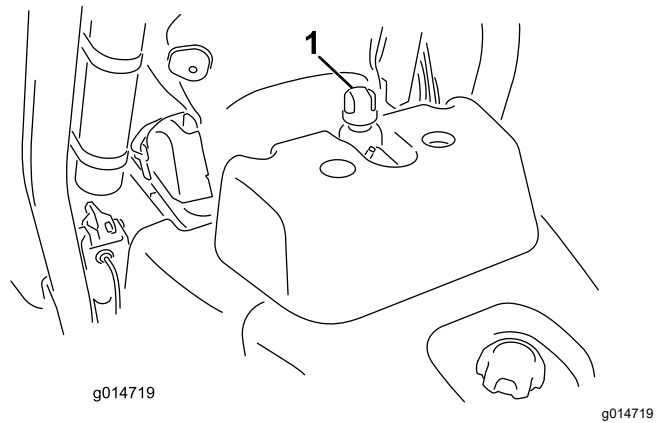

Figure 49

**Note:** Many hydraulic fluids are almost colorless, making it difficult to spot leaks. A red dye additive for the hydraulic fluid is available in 20 ml (0.67 fl oz) bottles. A bottle is sufficient for 15 to 22 L (4 to 6 US gallons) of hydraulic fluid. Order Part No. 44-2500 from your authorized Toro distributor.

**Important:** Toro Premium Synthetic Biodegradable Hydraulic Fluid is the only synthetic biodegradable fluid approved by Toro. This fluid is compatible with the elastomers used in Toro hydraulic systems and is suitable for a wide-range of temperature conditions. This fluid is compatible with conventional mineral oils, but for maximum biodegradability and performance, the hydraulic system should be thoroughly flushed of conventional fluid. The oil is available in 19 L (5 US gallons) pails or 208 L (55 US gallons) from your authorized Toro distributor.

## Checking the Hydraulic-Fluid Level

The hydraulic-fluid reservoir is filled at the factory with high quality hydraulic fluid. Before operating the machine each day, check the level of the hydraulic fluid. Your machine has a dipstick or a white plastic window on the front of the hydraulic-fluid reservoir (behind the seat on the left side of the machine) that is used to check the hydraulic-fluid level. The fluid should be between the window lines or the dipstick marks; if not, add more appropriate fluid.

Refer to [Figure 49](#) for this procedure.

1. Hydraulic-tank cap or dipstick location

1. Position the machine on a level surface.  
**Note:** Ensure that the machine has cooled down so that the fluid is cold.
2. Check the fluid level according to the tank on your machine:
  - If your tank has a sight window, check the oil level there and proceed to step 5.
  - If your tank does not have a sight window, locate the dipstick on the top of the hydraulic tank and proceed to step 3.
3. Remove the dipstick and wipe it with a clean rag, then screw the dipstick back into the tank.
4. Remove the dipstick and check the fluid level. If the fluid is between the marks on the dipstick, the level is sufficient. If the level is not between the marks, more fluid is needed.
5. Remove the cap or dipstick (depending on your machine) from the hydraulic fluid tank and slowly fill the tank with the appropriate high-quality hydraulic fluid until the level is between the 2 lines on the sight window or 2 marks on the dipstick.
6. Install the cap or dipstick and wipe up any fluid that may have spilled.

**Important:** Check the level of the hydraulic fluid before the engine is first started and daily thereafter.

# Changing the Hydraulic Fluid and Filter

**Service Interval:** Every 800 hours—If you **are not** using the recommended hydraulic fluid or have ever filled the reservoir with an alternative fluid, change the hydraulic fluid, filter, and tank breather.

Every 1,000 hours—If you **are** using the recommended hydraulic fluid, change the hydraulic-fluid filter.

Every 2,000 hours—If you **are** using the recommended hydraulic fluid, change the hydraulic fluid.

**Hydraulic Fluid Capacity:** 25.7 L (6.8 US gallons)

If the fluid becomes contaminated, have your authorized Toro distributor flush the system. Contaminated fluid looks milky or black when compared to clean fluid.

1. Clean the area around the filter mounting area (Figure 50). Place a drain pan under the filter and remove the filter.

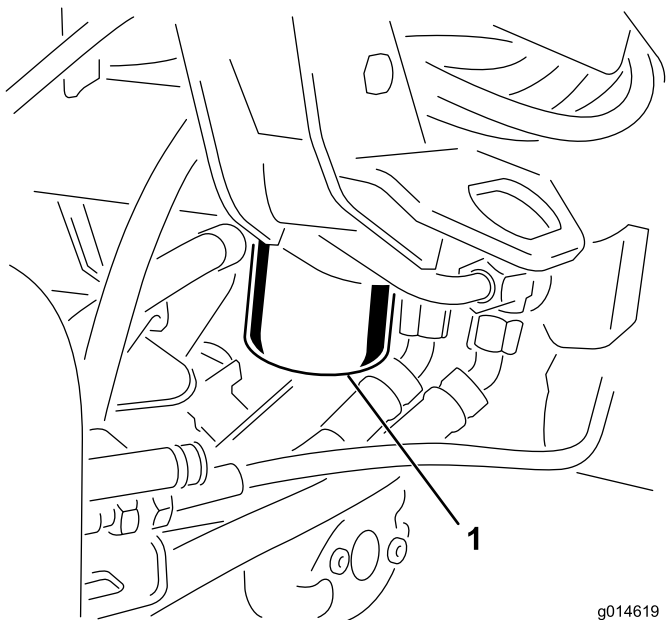

Figure 50

g014619  
g014619

1. Hydraulic-fluid filter

**Note:** If you will not be draining the fluid, disconnect and plug the hydraulic line going to the filter.

2. Fill the replacement filter with the appropriate hydraulic fluid, lubricate the sealing gasket, and hand turn it until the gasket contacts the filter head. Then tighten it 3/4 turn further.
3. Fill the hydraulic reservoir with hydraulic fluid; refer to [Hydraulic Fluid Specifications \(page 44\)](#)

and [Checking the Hydraulic-Fluid Level \(page 45\)](#).

4. Start the machine and run it at idle for 3 to 5 minutes to circulate the fluid and remove any air trapped in the system. Shut off the engine and check the fluid level.
5. Dispose of the fluid and filter properly.

# Checking the Hydraulic Lines and Hoses

Check the hydraulic lines and hoses daily for leaks, kinked lines, loose mounting supports, wear, loose fittings, weather deterioration, and chemical deterioration. Make all necessary repairs before operating.

# Cutting Unit Maintenance

## Blade Safety

A worn or damaged blade or bedknife can break, and a piece could be thrown toward you or bystanders, resulting in serious personal injury or death.

- Inspect the blades and bedknives periodically for excessive wear or damage.
- Use care when checking the blades. Wear gloves and use caution when servicing them. Only replace or backlap the blades and bedknives; never straighten or weld them.
- On machines with multiple cutting units, take care when rotating a cutting unit; it can cause the reels in the other cutting units to rotate.

## Installing and Removing the Cutting Units

### ⚠ CAUTION

The cutting-unit blades are sharp and can cut your hands.

Wear heavy leather or cut-resistant gloves when handling the cutting units.

**Note:** When sharpening, setting the height of cut, or performing other maintenance procedures on the cutting units, store the cutting unit reel motors in the storage location on the front of the suspension arms to prevent damage to them.

**Important:** Do not raise the suspension to the transport position when the reel motors are in the holders in the machine frame. Damage to the motors or hoses could result.

**Important:** Whenever you need to tip the cutting unit, prop up the rear of the cutting unit to ensure that the nuts on the bedbar adjusting screws are not resting on the work surface (Figure 51).

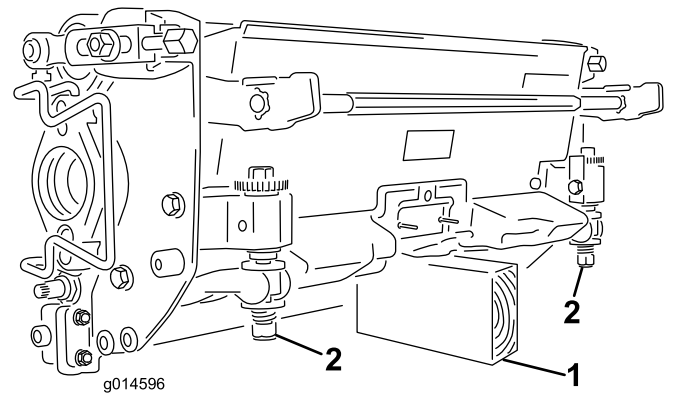

Figure 51

1. Prop (not provided)
2. Bedbar-adjusting-screw nut (2)

## Installing the Cutting Units

1. Lift up on the footrest and swing it open, allowing access to the center cutting unit position (Figure 52).

### ⚠ CAUTION

The footrest can pinch fingers if it falls into the closed position.

Keep your fingers clear of the area where the footrest seats while it is open.

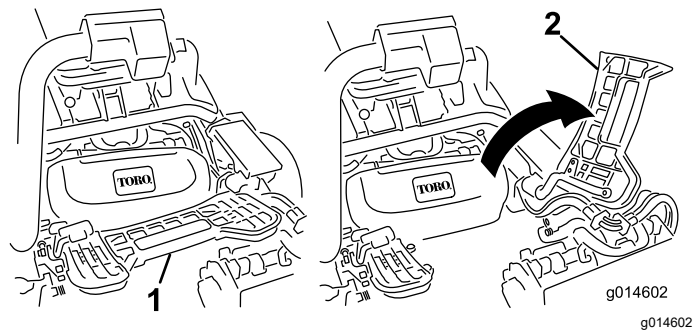
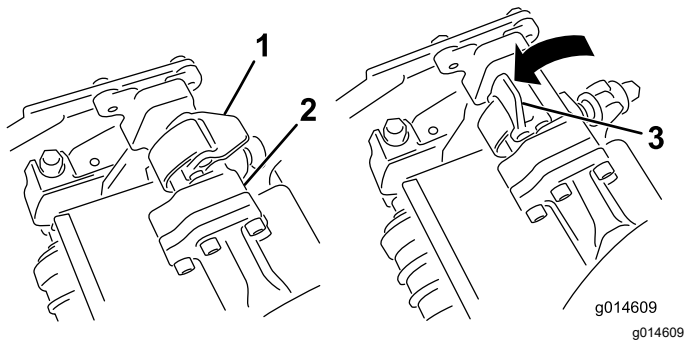

Figure 52

1. Footrest—closed
2. Footrest—open

2. Position the cutting unit under the center suspension arm.
3. With the latches on the suspension-arm bar pointing up (i.e., open) (Figure 53), push the suspension arm down so that the bar fits over the bar across the top of the cutting unit (Figure 54).



**Figure 53**

- 1. Latch—closed position
- 2. Suspension-arm bar
- 3. Latch—open position

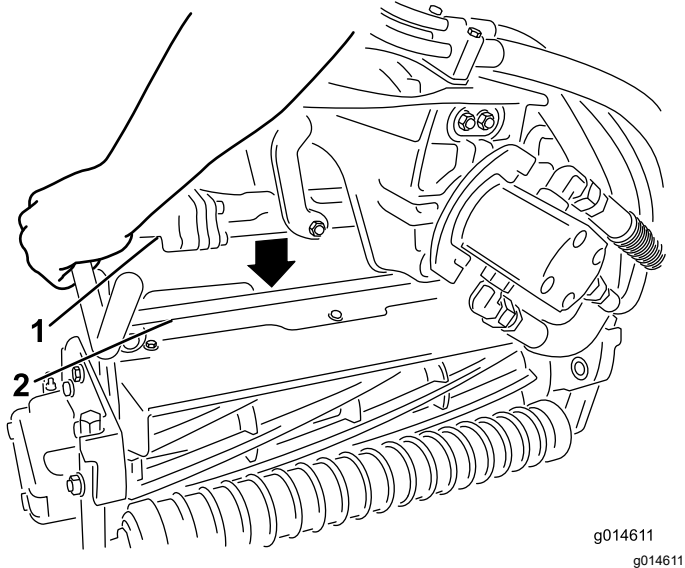
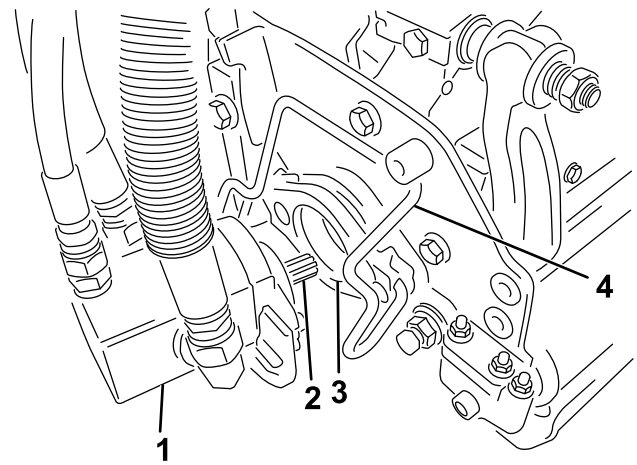

**Figure 54**

- 1. Suspension-arm bar
- 2. Cutting-unit bar

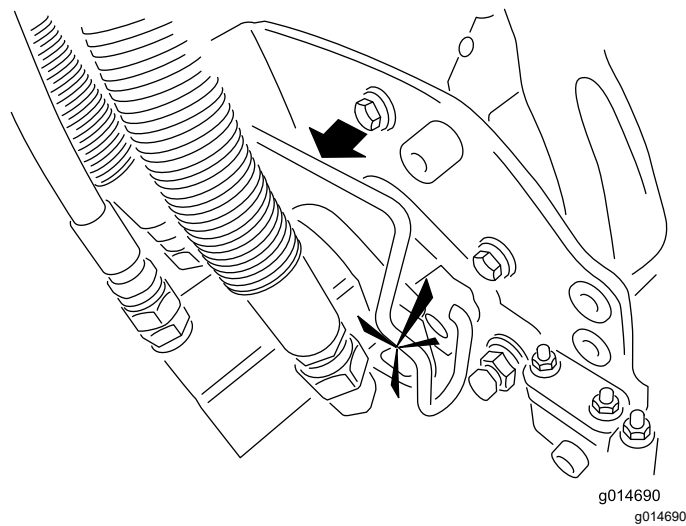

**Figure 55**

- 1. Reel motor
- 2. Spline shaft
- 3. Cavity
- 4. Motor-retaining bar

- 4. Close the latches down and around the cutting-unit bar and lock them in place (Figure 53).

**Note:** You can hear a click and feel when the latches are properly locked in place.

- 5. Coat the spline shaft of the cutting unit motor with clean grease (Figure 55).
- 6. Insert the motor into the left side of the cutting unit (as viewed from the operator's position) and pull the motor retaining bar on the cutting unit toward the motor until you hear a click from both sides of the motor (Figure 55).

- 7. Mount a grass basket onto the basket hooks on the suspension arm.
- 8. Repeat this procedure for the other cutting units.

## Removing the Cutting Units

- 1. Park the machine on a clean level surface, lower the cutting units to the ground until the suspension hydraulics are fully extended, set the parking brake, shut off the engine, and remove the key.
- 2. Push the motor retaining bar out of the slots on the motor toward the cutting unit and remove the motor from the cutting unit.

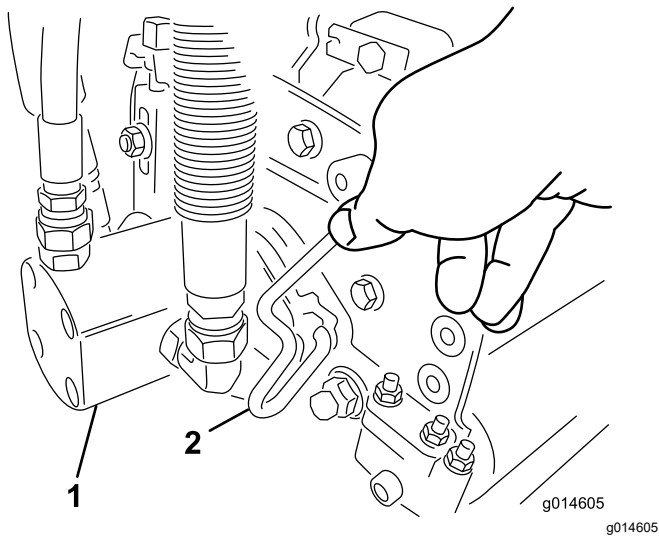

Figure 56

1. Reel motor
2. Motor-retaining bar

3. Move the motor to the storage location on the front of the suspension arm (Figure 57).

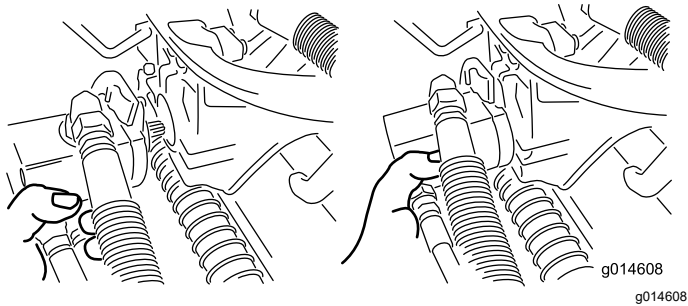

Figure 57

**Note:** When sharpening, setting the height of cut, or performing other maintenance procedures on the cutting units, store the cutting unit reel motors in the storage location on the front of the suspension arms to prevent damage to them.

**Important:** Do not raise the suspension to the transport position when the reel motors are in the holders in the machine frame. Damage to the motors or hoses could result. If you must move the traction unit without the cutting units installed, secure them to the suspension arms using cable ties.

4. Open the latches on the suspension-arm bar of the cutting unit you are removing (Figure 53).
5. Disconnect the latches from the cutting-unit bar.
6. Roll the cutting unit out from under the suspension arm.
7. Repeat steps 2 through 6 for the other cutting units as required.

## Checking the Reel-to-Bedknife Contact

Each day before operating the machine, check the reel-to-bedknife contact, regardless if the quality of cut had previously been acceptable. There must be light contact across the full length of the reel and bedknife; refer to the Cutting Unit *Operator's Manual*.

## Backlapping the Reels

### ⚠ WARNING

Contact with the reels or other moving parts can result in personal injury.

- Keep your fingers, hands, and clothing away from the reels or other moving parts.
- Never attempt to turn the reels by hand or foot while the engine is running.

1. Park the machine on a level surface, lower the cutting units, shut off the engine, remove the key, and engage the parking brake.
2. Remove the plastic cover to the left side of the seat.
3. Make initial reel to bedknife adjustments appropriate for backlapping on all cutting units which are to be backlapped; refer to the Cutting Unit *Operator's Manual*.

### ⚠ DANGER

Changing the engine speed while backlapping may cause the reels to stall.

- Never change the engine speed while backlapping.
  - Backlap only at idle engine speed.
4. Start the engine and run at low idle speed.
  5. Rotate the backlap lever to the REVERSE (R) position (Figure 58).

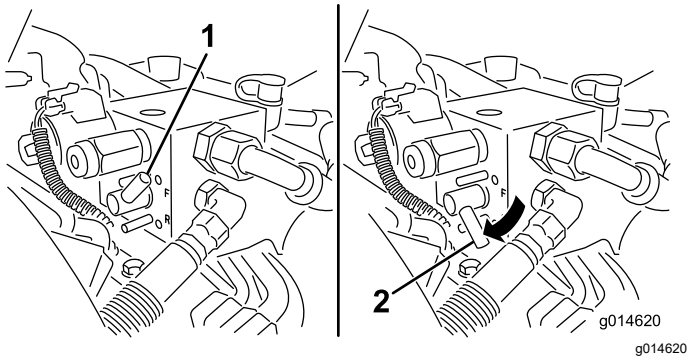

**Figure 58**

1. Backlap lever—FORWARD position
2. Backlap lever—REVERSE position

6. Rotate the reel-speed control to setting 1 (Figure 59).

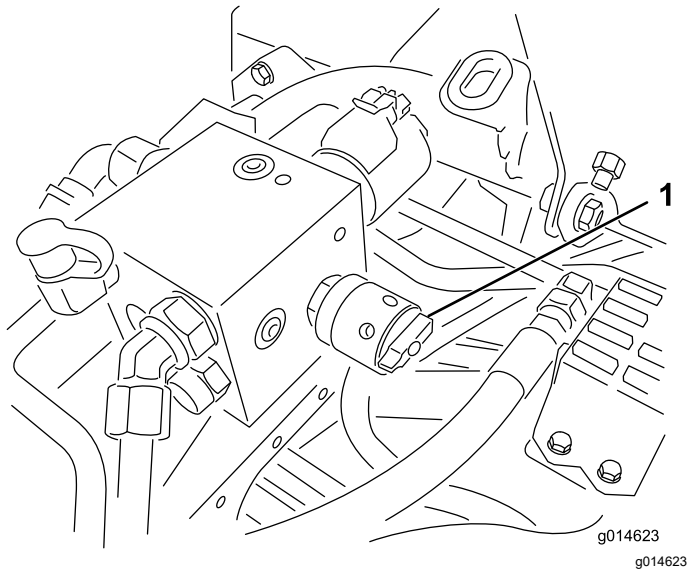

**Figure 59**

1. Reel-speed control

7. With the functional-control lever in the NEUTRAL position, move the raise/lower mow control forward to start the backlapping operation on the designated reels.
8. Apply lapping compound with a long-handled brush. Never use a short-handled brush.
9. If the reels stall or become erratic while backlapping, select a higher reel speed setting until the speed stabilizes, then return the reel speed to setting 1 or to your desired speed.
10. To make an adjustment to the cutting units while backlapping, turn the reels off by moving the raise/lower mow control rearward and shut off the engine. After completing adjustments, repeat steps 4 through 8.
11. Repeat the procedure for all cutting units you want to backlap.

12. When finished, return the backlap levers to the FORWARD (F) position, replace the cover, and wash all lapping compound off of the cutting units. Adjust cutting unit reel to bedknife as needed. Move the cutting unit reel speed control to the desired mowing position.

**Important:** If the backlap lever is not returned to the FORWARD (F) position after backlapping, the cutting units will not raise or function properly.

## Setting the Reel Speed





To achieve a consistent, high-quality cut and a uniform after-cut appearance, you must correctly set the reel speed control (located on the manifold block under the cover to the left of the seat). Adjust the reel speed control as follows:

1. Select the height of cut at which the cutting units are set.
2. Choose the desired ground speed best suites conditions.
3. Use the table that follows to determine the reel-speed setting for your 5-, 8-, 11-, or 14-blade cutting units; refer to [Reel Speed Table \(page 51\)](#).
4. Adjust the reel speed by rotating the knob (Figure 59) until the indicator arrows are in line with the number you determined in step 3.

**Note:** You can increase or decrease the reel speed to compensate for turf conditions.

# Reel Speed Table

Reel Speed Table

 Height of Cut	 5-blade cutting unit		 8-blade cutting unit		 11-blade cutting unit		 14-blade cutting unit
	Ground Speed						
	6.1 km/h (3.8 mph)	8.0 km/h (5.0 mph)	6.1 km/h (3.8 mph)	8.0 km/h (5.0 mph)	6.1 km/h (3.8 mph)	8.0 km/h (5.0 mph)	6.1 km/h (3.8 mph)
	Reel speed setting						
1.6 mm (0.062 inch)	*N/R	*N/R	9	*N/R	9	*N/R	9
2.4 mm (0.094 inch)	*N/R	*N/R	9	*N/R	9	*N/R	9
3.2 mm (0.125 inch)	*N/R	*N/R	9	*N/R	9	*N/R	*N/R
4.0 mm (0.156 inch)	*N/R	*N/R	9	*N/R	9	*N/R	*N/R
4.8 mm (0.188 inch)	*N/R	*N/R	9	*N/R	7	*N/R	*N/R
5.5 mm (0.218 inch)	*N/R	*N/R	9	*N/R	6	*N/R	*N/R
6.4 mm (0.250 inch)	7	*N/R	6	7	5	7	*N/R
7.9 mm (0.312 inch)	6	*N/R	5	6	4	6	*N/R
9.5 mm (0.375 inch)	6	7	4	5	4	5	*N/R
11.1 mm (0.438 inch)	6	6	4	5	3	4	*N/R
12.7 mm (0.500 inch)	5	6	3	4	*N/R	*N/R	*N/R
15.9 mm (0.625 inch)	4	5	3	3	*N/R	*N/R	*N/R
19.0 mm (0.750 inch)	3	4	3	3	*N/R	*N/R	*N/R
22.2 mm (0.875 inch)	3	4	*N/R	3	*N/R	*N/R	*N/R
25.4 mm (1.000 inch)	3	3	*N/R	*N/R	*N/R	*N/R	*N/R

\*N/R: Not Recommended

## Diagnostics System

### Diagnosing the Service Indicator Light

The service indicator light illuminates in the event of a fault in the machine. When this light is on, you can access the computer codes to diagnose the problem by entering diagnostic mode. In diagnostic mode,

the service indicator light flashes a number of times, giving you the error code that you or your authorized Toro distributor can use to identify the problem.

**Note:** You cannot start the engine in diagnostic mode.

### Entering Diagnostic Mode

1. Stop the machine, engage the parking brake, and turn the ignition key to the OFF position.

2. Move the functional-control lever to the TRANSPORT position.
3. Ensure that the backlap lever is set to the FORWARD (F) position.
4. Get off the seat.
5. Hold the raise/lower mow control in the RAISED position.
6. Turn the ignition switch to the RUN position.
7. Count the codes as they begin to flash (you may release the raise/lower mow control once they begin flashing).

When finished, turn the key to the OFF position to exit diagnostic mode.

## Determining the Error Code

The system will display the last 3 faults that occurred in the last 40 hours. It displays the faults through a series of blinking lights, as follows:

- If there are no faults, the light will blink steadily at a medium rate without pauses (1 Hz).
- If there is a fault, it will first blink the tens place, followed by a pause, followed by the ones place. For the following examples, a # represents a blink. Examples:
  - If the code is 15, the blink pattern will be #\_#####
  - If the code is 42, the blink pattern will be #####\_##
  - If the code is 123, the blink pattern will be #####\_###
- If there are more than 1 fault, the tens place of the next fault will begin after a pause after the ones place of the first fault.

**Note:** The system stores only the 3 most recent fault codes.

For a list of error codes, refer to your authorized Toro distributor or the *Service Manual*.

# Storage

## Storage Safety

- Shut off the machine, remove the key, and wait for all movement to stop before you leave the operator's position. Allow the machine to cool before adjusting, servicing, cleaning, or storing it.
- Do not store the machine or fuel container where there is an open flame, spark, or pilot light, such as on a water heater or other appliance.

## Preparing the Machine for Storage

If you wish to store the machine for a long period of time, the following steps should be performed prior to storage:

1. Refer to [Storage Safety \(page 52\)](#).
2. Remove accumulations of dirt and old grass clippings. Sharpen the blades and bedknives, if necessary; refer to the cutting unit *Operator's Manual*. Use a rust preventive on bedknives and blades. Grease and oil all lubrication points.
3. Block up the wheels to remove any weight on the tires.
4. Drain and replace the hydraulic fluid and filter and inspect the hydraulic lines and fittings. Replace, if necessary; refer to [Changing the Hydraulic Fluid and Filter \(page 46\)](#) and [Checking the Hydraulic Lines and Hoses \(page 46\)](#).
5. All fuel should be removed from the fuel tank. Run the engine until it stops from lack of fuel. Replace the fuel filter; refer to [Replacing the Fuel Filter/Water Separator \(page 37\)](#).
6. While the engine is still warm, drain the oil from the crankcase. Refill it with fresh oil; refer to [Changing the Engine Oil and Filter \(page 35\)](#).
7. Clean dirt and chaff from the cylinder, cylinder head fins, and blower housing.
8. Remove the battery and charge it fully. Either store it on the shelf or on the machine. Leave the cables disconnected if it is stored on the machine. Store the battery in a cool atmosphere to avoid quick deterioration of the charge in the battery.
9. If possible, store the machine in a warm, dry location.

**Notes:**

**Notes:**

**Notes:**

# California Proposition 65 Warning Information

## What is this warning?

You may see a product for sale that has a warning label like the following:



**WARNING: Cancer and Reproductive Harm—[www.p65Warnings.ca.gov](http://www.p65Warnings.ca.gov).**

## What is Prop 65?

Prop 65 applies to any company operating in California, selling products in California, or manufacturing products that may be sold in or brought into California. It mandates that the Governor of California maintain and publish a list of chemicals known to cause cancer, birth defects, and/or other reproductive harm. The list, which is updated annually, includes hundreds of chemicals found in many everyday items. The purpose of Prop 65 is to inform the public about exposure to these chemicals.

Prop 65 does not ban the sale of products containing these chemicals but instead requires warnings on any product, product packaging, or literature with the product. Moreover, a Prop 65 warning does not mean that a product is in violation of any product safety standards or requirements. In fact, the California government has clarified that a Prop 65 warning "is not the same as a regulatory decision that a product is 'safe' or 'unsafe.'" Many of these chemicals have been used in everyday products for years without documented harm. For more information, go to <https://oag.ca.gov/prop65/faqs-view-all>.

A Prop 65 warning means that a company has either (1) evaluated the exposure and has concluded that it exceeds the "no significant risk level"; or (2) has chosen to provide a warning based on its understanding about the presence of a listed chemical without attempting to evaluate the exposure.

## Does this law apply everywhere?

Prop 65 warnings are required under California law only. These warnings are seen throughout California in a wide range of settings, including but not limited to restaurants, grocery stores, hotels, schools, and hospitals, and on a wide variety of products. Additionally, some online and mail order retailers provide Prop 65 warnings on their websites or in catalogs.

## How do the California warnings compare to federal limits?

Prop 65 standards are often more stringent than federal and international standards. There are various substances that require a Prop 65 warning at levels that are far lower than federal action limits. For example, the Prop 65 standard for warnings for lead is 0.5 µg/day, which is well below the federal and international standards.

## Why don't all similar products carry the warning?

- Products sold in California require Prop 65 labelling while similar products sold elsewhere do not.
- A company involved in a Prop 65 lawsuit reaching a settlement may be required to use Prop 65 warnings for its products, but other companies making similar products may have no such requirement.
- The enforcement of Prop 65 is inconsistent.
- Companies may elect not to provide warnings because they conclude that they are not required to do so under Prop 65; a lack of warnings for a product does not mean that the product is free of listed chemicals at similar levels.

## Why does Toro include this warning?

Toro has chosen to provide consumers with as much information as possible so that they can make informed decisions about the products they buy and use. Toro provides warnings in certain cases based on its knowledge of the presence of one or more listed chemicals without evaluating the level of exposure, as not all the listed chemicals provide exposure limit requirements. While the exposure from Toro products may be negligible or well within the "no significant risk" range, out of an abundance of caution, Toro has elected to provide the Prop 65 warnings. Moreover, if Toro does not provide these warnings, it could be sued by the State of California or by private parties seeking to enforce Prop 65 and subject to substantial penalties.