



**ProLine 21-inch Recycler<sup>®</sup>/  
Rear-Bagging**

**Walk Power Lawn Mower**

Model No. 22175—240000001 and Up

Model No. 22176—240000001 and Up

**Operator's Manual**



## Warning



### CALIFORNIA

#### Proposition 65 Warning

**The engine exhaust from this product contains chemicals known to the State of California to cause cancer, birth defects, or other reproductive harm.**

**Important** This engine is not equipped with a spark arrester muffler. It is a violation of California Public Resource Code Section 4442 to use or operate this engine on any forest-covered, brush-covered or grass-covered land. Other states or federal areas may have similar laws.

This spark ignition system complies with Canadian ICES-002.

Ce système d'allumage par étincelle de véhicule est conforme à la norme NMB-002 du Canada.

**The enclosed Engine Owner's Manual is supplied for information regarding The U.S. Environmental Protection Agency (EPA) and the California Emission Control Regulation of emission systems, maintenance and warranty.**

**Keep this engine Owner's Manual with your unit. Should this engine Owner's Manual become damaged or illegible, replace immediately. Replacements may be ordered through the engine manufacturer.**

## Contents

	Page
Introduction .....	2
Safety .....	3
Safe Operating Practices .....	3
Toro Lawn Mower Safety .....	4
Safety and Instruction Decals .....	5
Assembly .....	6
Installing the Handle .....	6
Installing the Starter Rope .....	6
Installing the Fuel Tank and the Fuel Line .....	6
Installing the Discharge Tunnel Plug .....	7
Before Starting .....	7
Filling the Crankcase with Oil .....	7
Filling the Fuel Tank with Gasoline .....	8
Operation .....	9
Controls .....	9
Starting the Engine .....	10
Stopping the Engine .....	10
Operating the Blade and the Self-Propel Drive ..	10

	Page
Using the Discharge Tunnel Plug .....	11
Adjusting the Cutting Height .....	11
Using the Grass Bag .....	11
Operating Tips .....	12
Maintenance .....	14
Recommended Maintenance Schedule .....	14
Checking the Engine Oil Level .....	15
Cleaning the Underside of the Lawn Mower Housing .....	15
Cleaning the Discharge Tunnel and Plug .....	16
Servicing the Air Filter .....	16
Changing the Engine Oil .....	17
Maintaining the Cutting Blade .....	17
Emptying the Fuel Tank and Cleaning the Fuel Filter .....	18
Cleaning under the Belt Cover .....	19
Lubricating the Pivot Arms .....	19
Adjusting the Self-propel Drive .....	19
Servicing the Spark Plug .....	20
Changing the Oil Filter .....	20
Lubricating the Gear Case .....	21
Adjusting the Blade Brake Cable .....	21
Servicing the Wheels .....	22
Storage .....	22
Preparing the Fuel System .....	22
Preparing the Engine .....	23
General Information .....	23
Removing the Lawn Mower from Storage .....	23
Accessories .....	23
Troubleshooting .....	24
The Toro Total Coverage Guarantee .....	28

## Introduction

Read this manual carefully to learn how to operate and maintain your product properly. The information in this manual can help you and others avoid injury and product damage. Although Toro designs and produces safe products, you are responsible for operating the product properly and safely.

You may contact Toro directly at [www.Toro.com](http://www.Toro.com) for product and accessory information, help finding a dealer, or to register your product.

Whenever you need service, genuine Toro parts, or additional information, contact an Authorized Service Dealer or Toro Customer Service and have the model and serial numbers of your product ready. Figure 1 illustrates the location of the model and serial numbers on the product.

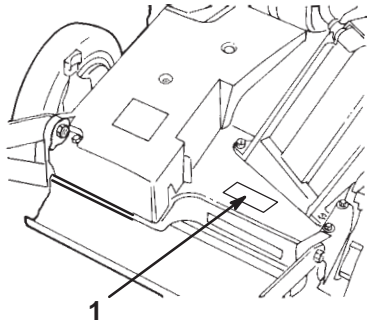

**Figure 1**

1. Location of the model and serial numbers

Write the product model and serial numbers in the space below:

<p><b>Model No.</b> _____</p> <p><b>Serial No.</b> _____</p>
--

This manual identifies potential hazards and has special safety messages that help you and others avoid personal injury and even death. **Danger**, **Warning**, and **Caution** are signal words used to identify the level of hazard. However, regardless of the hazard, be extremely careful.

**Danger** signals an extreme hazard that **will** cause serious injury or death if you do not follow the recommended precautions.

**Warning** signals a hazard that **may** cause serious injury or death if you do not follow the recommended precautions.

**Caution** signals a hazard that may cause minor or moderate injury if you do not follow the recommended precautions.

This manual uses 2 other words to highlight information.

**Important** calls attention to special mechanical information and **Note:** emphasizes general information worthy of special attention.

# Safety

**This lawn mower meets or exceeds the CPSC blade safety requirements for walk-behind rotary lawn mowers and the B71.4 specifications of the American National Standards Institute in effect at the time of production.**

<span style="font-weight: bold; font-size: 1.2em; margin: 0 10px;">Warning</span>
<p><b>Engine exhaust contains carbon monoxide, an odorless, deadly poison that can kill you.</b></p> <p><b>Do not run the engine indoors or in an enclosed area.</b></p>

To ensure maximum safety and best performance, and to gain knowledge of the product, it is essential that you and any other operator of the lawn mower read and understand the contents of this manual before the engine is ever started.

This is the safety alert symbol. It is used to alert you to potential personal injury hazards. Obey all safety messages that follow this symbol to avoid possible injury or death.

Improperly using or maintaining this lawn mower could result in injury or death. To reduce this potential, comply with the following safety instructions.

## Safe Operating Practices

The following instructions are from the ANSI/OPEI B71.4–1999 standard.

### Training

- Read the Operator’s Manual and other training material. If the operator(s) or mechanic(s) can not read English it is the owner’s responsibility to explain this material to them.
- Become familiar with the safe operation of the equipment, operator controls, and safety signs.
- All operators and mechanics should be trained. The owner is responsible for training the users.
- Never let children or untrained people operate or service the equipment. Local regulations may restrict the age of the operator.
- The owner/user can prevent and is responsible for accidents or injuries occurring to themselves, other people, or property.

## Preparation

- Only use accessories and attachments approved by the manufacturer.
- Wear appropriate clothing including hard hat, safety glasses, and ear protection. Long hair, loose clothing or jewelry may get tangled in moving parts.
- Inspect the area where the equipment is to be used and remove all objects such as rocks, toys and wire which can be thrown by the machine.
- Use extra care when handling gasoline and other fuels. They are flammable and vapors are explosive.
  - Use only an approved container.
  - Never remove gas cap or add fuel with engine running. Allow engine to cool before refueling. Do not smoke.
  - Never refuel or drain the machine indoors.
- Check that operator's presence controls, safety switches and shields are attached and functioning properly. Do not operate unless they are functioning properly.

## Operation

- Never run an engine in an enclosed area.
- Only operate in good light, keeping away from holes and hidden hazards.
- Only start engine from the operator's position.
- Be sure of your footing, especially when backing up. Walk, don't run. Never operate on wet grass. Reduced footing could cause slipping.
- Slow down on hillsides. Be sure to travel side to side on hillsides. Turf conditions can affect the machine's stability. Use caution while operating near drop-offs.
- Do not change the engine governor setting or overspeed the engine.
- Stop on level ground and shut off engine before leaving the operator's position for any reason including emptying the catcher or unclogging the chute.
- Stop equipment and inspect blade after striking objects or if an abnormal vibration occurs. Make necessary repairs before resuming operations.
- Keep hands and feet away from the cutting units.
- Look behind and down before backing up to be sure of a clear path.
- Keep pets and bystanders away.
- Slow down and use caution when crossing roads and sidewalks.

- Stop blade if you are not mowing.
- Be aware of the mower discharge direction and do not point it at anyone.
- Do not operate the mower under the influence of alcohol or drugs.
- Use care when approaching blind corners, shrubs, trees, or other objects that may obscure vision.
- Do not operate the lawn mower without either the grass catcher or the guard in place.

## Maintenance and Storage

- Stop engine and disconnect spark plug wire. Wait for all movement to stop before adjusting, cleaning or repairing.
- Clean grass and debris from cutting unit, drive, muffler, and engine to help prevent fires. Clean up oil or fuel spillage.
- Let engine cool before storing and do not store near flame.
- Shut off fuel while storing or transporting. Do not store fuel near flames or drain indoors.
- Never allow untrained personnel to service machine.
- Remove spark plug wire before making any repairs.
- Use care when checking blade. Wrap the blade or wear gloves, and use caution when servicing them. Only replace blade. Never straighten or weld it.
- Keep hands and feet away from moving parts. If possible, do not make adjustments with the engine running.
- Keep all parts in good working condition and all hardware tightened. Replace all worn or damaged decals.

## Toro Lawn Mower Safety

The following list contains safety information specific to Toro products or other safety information that you must know that is not included in the ANSI/OPEI standard.

This product is capable of amputating hands and feet, and of throwing objects. Always follow all safety instructions to avoid serious injury or death.

Use this product only for cutting and mulching grass, or, when equipped with a grass bagger, for catching cut grass.

- Stop the lawn mower if anyone enters the area.
- Do not operate the lawn mower without either the grass catcher or the guard in place.

- Do not touch the lawn mower or attachment parts which may be hot from operation. Allow the lawn mower to cool down before attempting to maintain, adjust, or service it.

## Safety and Instruction Decals



Safety decals and instructions are easily visible to the operator and are located near any area of potential danger. Replace any decal that is damaged or lost.



39-5770



68-7410



74-1970 (Self-propel Model only)

- Transmission speeds
- Neutral



92-1779

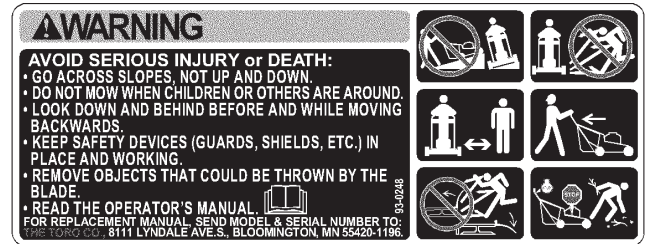

93-0248



94-9418

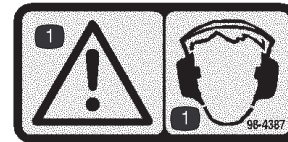

98-4387

- Warning—wear hearing protection.

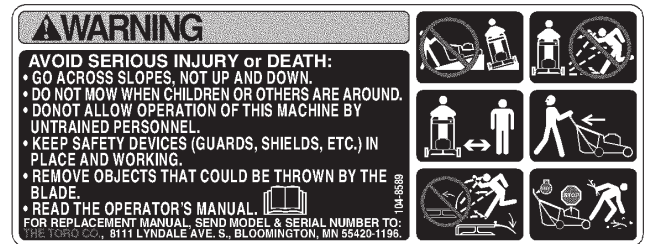

104-8589



106-0690 (Self-propel Model only)

# Assembly

**Note:** Determine the left and right sides of the machine from the normal operating position.

## Installing the Handle

1. Mount the handle to the outside of the lawn mower housing (using the bottom hole) with 2 5/16-18 x 1-1/4 in. cap screws, washers, and thin nylon insert locknuts.
2. Secure the handle latches to the handle with 2 cap screws (5/16-18 x 1-1/2 in.), washers, and nylon insert locknuts (Fig. 2).

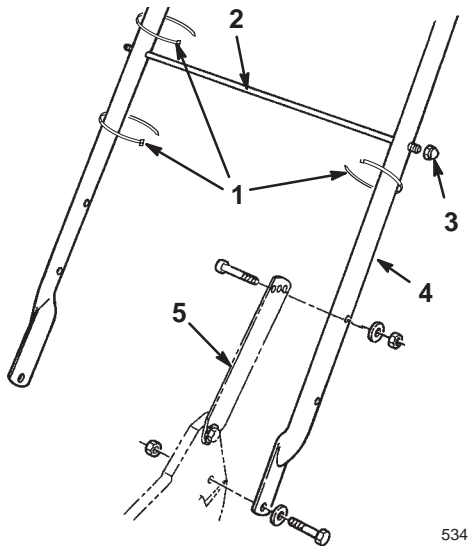

Figure 2

- |                    |                 |
|--------------------|-----------------|
| 1. Cable ties      | 4. Handle       |
| 2. Bag support rod | 5. Handle latch |
| 3. Cap locknut     |                 |

**Note:** You can adjust the handle height for comfortable operation. Stand behind the handle to determine the height. To adjust the handle height, position the cap screws and the locknuts that secure the handle latches to the handle into the other mounting holes in the latches.

3. Slide the bag support rod through the second from the top mounting holes in the handle and secure each end with a cap locknut (Fig. 2).
4. Use a cable ties to secure the control cables to the handle.

## Installing the Starter Rope

Pull the starter rope through the rope guide on the handle (Fig. 3).

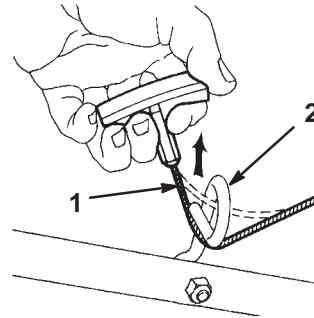

Figure 3

- |                 |               |
|-----------------|---------------|
| 1. Starter rope | 2. Rope guide |
|-----------------|---------------|

**Note:** To make the rope easier to install, squeeze the control bar on the handle.

## Installing the Fuel Tank and the Fuel Line

1. Start the two self-tapping screws into the bottom of the fuel tank and then remove the screws (Fig. 4).

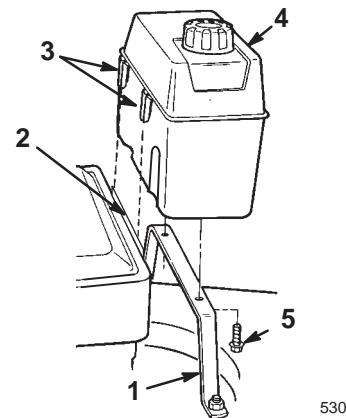
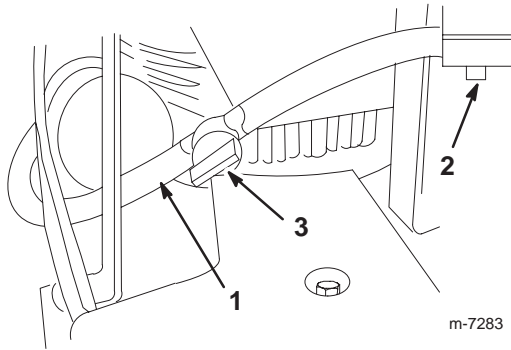

Figure 4

- |                      |                           |
|----------------------|---------------------------|
| 1. Tank base         | 4. Fuel tank              |
| 2. Fuel tank bracket | 5. Self-tapping screw (2) |
| 3. Plastic clips     |                           |

2. Hook the plastic clips on the front of the fuel tank onto the fuel tank bracket (Fig. 4).
3. Secure the fuel tank to the tank base with the two self-tapping screws (Fig. 4). **Do not overtighten the screws.**

- Remove the red cap from the end of the fuel line and from the end of the elbow fitting on the fuel tank (Fig. 5).



**Figure 5**

- Fuel line
- Elbow fitting
- Fuel valve

- Slide the end of the fuel line onto the elbow fitting (Fig. 5).

**Note:** Route the fuel line under the oil filter.

- Secure the fuel line in place with the fuel line clamp (Fig. 5).

## Installing the Discharge Tunnel Plug

- Open the discharge door by pulling forward on the handle and moving it rearward (Fig. 6). Hold the discharge door handle to prevent the spring-loaded door from closing while you insert the plug.

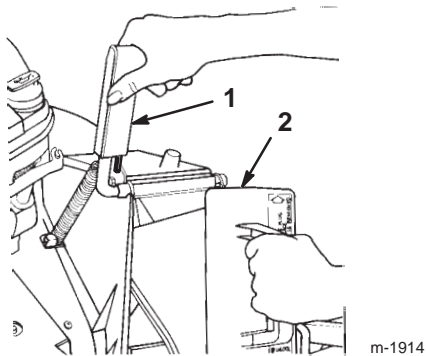

**Figure 6**

- Discharge door handle
- Plug rotated clockwise

- Since the plug is slightly wider than the discharge tunnel opening, rotate the plug clockwise slightly while inserting it (Fig. 6).

**Note:** Ensure that the arrow on the plug decal points upward.

- Push the plug all the way in until the spring clip on the bottom of the plug clicks into place, locking the plug securely into the discharge tunnel (Fig. 7).

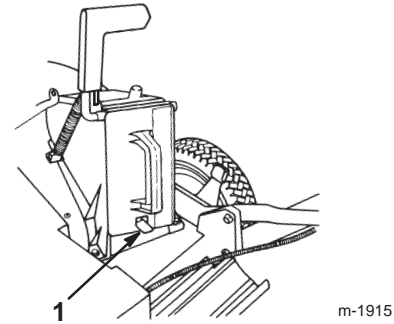

**Figure 7**

- Spring clip

- Release the discharge door handle to lock the top of the plug.

## Before Starting

### Filling the Crankcase with Oil

Initially, fill the crankcase with 30 ounces (0.88 liters) of oil. Use only high-quality SAE 30 or SAE 10W30 weight detergent oil that has the American Petroleum Institute (API) service classification SF, SG, SH, or SJ.

Oil Capacity	
With Oil Filter	30 ounces (0.88 L)
Without Oil Filter	24 ounces (0.70 L)

Before each use, ensure that the oil level is between the Add and Full marks on the dipstick (Fig. 8).

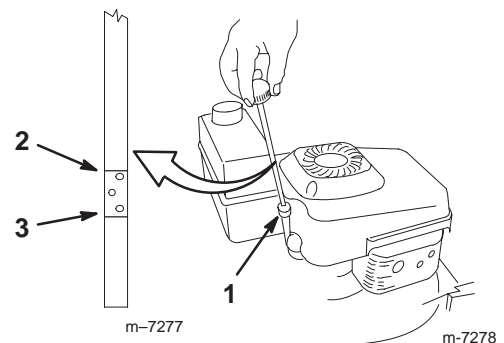

**Figure 8**

- Dipstick
- Full
- Add

**Note:** When the crankcase is empty, pour about 3/4 of the crankcase capacity of oil in the crankcase, then follow the procedure in this section.

To add oil:

1. Move the lawn mower to a level surface.
  2. Clean around the dipstick (Fig. 8).
  3. Remove the dipstick by rotating the cap counterclockwise and pulling it out.
  4. Wipe the dipstick clean with a clean cloth.
  5. Insert the dipstick into the filler neck (but **do not rotate the cap clockwise to secure it**), then remove it.
  6. Read the oil level on the dipstick (Fig. 8).
  7. If the oil level reading is below the Add mark on the dipstick, **slowly** pour only enough oil into the filler hole to raise the oil level to the Full mark on the dipstick.
- Important** Do not overfill the crankcase with oil and run the engine; engine damage will result. Drain the excess oil until the oil level on the dipstick reads Full.
8. Insert the dipstick into the filler neck and rotate the cap clockwise until it is tight.

## Filling the Fuel Tank with Gasoline

For best results, use clean, fresh, lead-free gasoline with an octane rating of 87 or higher. To ensure freshness, purchase only the quantity of gasoline that you expect to use in 30 days. Using unleaded gasoline results in fewer combustion deposits and longer engine life. You may use leaded gasoline if unleaded gasoline is not available.

**Important** Do not add oil to the gasoline.

**Important** Do not use methanol, gasoline containing methanol, gasohol containing more than 10% ethanol, premium gasoline, or white gas. Using these fuels can damage the engine's fuel system.

**Important** Do not use gasoline that has been stored since the last mowing season or longer.



### Danger



**In certain conditions, gasoline is extremely flammable and highly explosive. A fire or explosion from gasoline can burn you and others and can damage property.**

- **Fill the fuel tank outdoors, in an open area, and when the engine is cold. Wipe up any gasoline that spills.**
- **Do not fill the fuel tank completely full. Add gasoline to the fuel tank until the level is 1/4 to 1/2 in. (6 to 13 mm) below the bottom of the filler neck. This empty space in the tank allows the gasoline to expand.**
- **Never smoke when handling gasoline, and stay away from an open flame or where a spark may ignite the gasoline fumes.**
- **Store gasoline in an approved fuel container and keep it out of the reach of children.**
- **Never buy more than a 30-day supply of gasoline.**



### Danger



**When fueling, under certain circumstances, a static charge can develop, igniting the gasoline. A fire or explosion from gasoline can burn you and others and damage property.**

- **Always place gasoline containers on the ground and away from your vehicle before filling.**
- **Do not fill gasoline containers inside a vehicle or on a truck or trailer bed because interior carpets or plastic truck bed liners may insulate the container and slow the loss of any static charge.**
- **When practical, remove gasoline-powered equipment from the truck or trailer and refuel the equipment with its wheels on the ground.**
- **If this is not possible, then refuel such equipment on a truck or trailer from a portable container, not from a gasoline dispenser nozzle.**
- **If you must use a gasoline dispenser nozzle, keep the nozzle in contact with the rim of the fuel tank or container opening at all times until fueling is complete.**

Use a fuel stabilizer/conditioner regularly during operation and storage. A stabilizer/conditioner cleans the engine during operation and prevents gum-like varnish deposits from forming in the engine during periods of storage.

**Important** Do not use fuel additives other than a fuel stabilizer/conditioner. Do not use fuel stabilizers with an alcohol base such as ethanol, methanol, or isopropanol.

1. Clean around the fuel tank cap (Fig. 9).

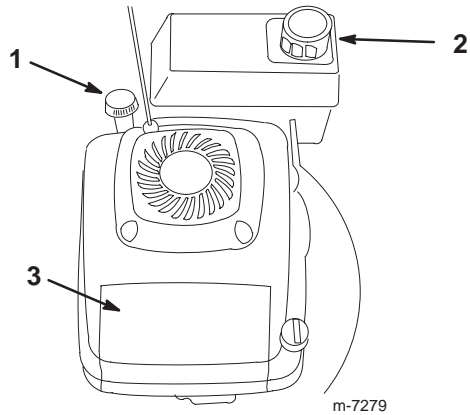

**Figure 9**

1. Oil fill/dipstick
2. Fuel tank cap
3. Air cleaner

2. Remove the cap from the tank.
3. Fill the fuel tank with unleaded gasoline to within 1/4 to 1/2 inch (6 to 13 mm) from the top of the tank. **Do not fill into the filler neck.**

**Important** Do not fill the tank more than 1/4 inch (6 mm) from the top of the tank because the gasoline must have room to expand.

4. Install the fuel tank cap and wipe up any spilled gasoline.

## Operation

**Note:** Determine the left and right sides of the machine from the normal operating position.

Each time before you mow, make sure that the self-propel drive and the blade control bail operate properly. When you release the blade control bail, the blade and self-propel drive should stop. If they do not, contact an Authorized Service Dealer.

**Caution**

**This machine produces sound levels in excess of 85dBA at the operator's ear and can cause hearing loss through extended periods of exposure.**

**Wear hearing protection when operating this machine.**

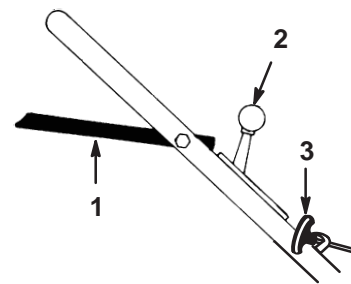

**Figure 10**

1. Caution
2. Wear hearing protection

## Controls

The blade control bail, throttle control, and starter handle are on the upper handle as shown in Figure 11.



**Figure 11**

1. Blade control bail
2. Throttle control
3. Starter handle

## Starting the Engine

1. Connect the wire to the spark plug (Fig. 12).

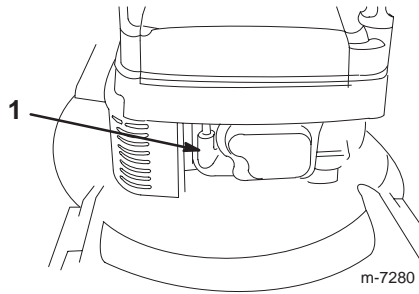



Figure 12

1. Spark-plug wire

2. Open the fuel valve (Fig. 9).
3. Move the throttle control to the  (**Choke**) position (Fig. 11).
4. Move the ground speed control to the  (**Neutral**) position (Fig. 13).

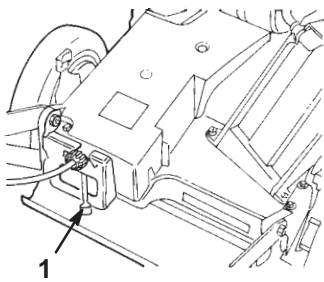



Figure 13

1. Ground speed control

5. Pull the starter handle (Fig. 9) lightly until you feel resistance, then pull it sharply.
6. Regulate the throttle and the ground speed control as desired when the engine starts.

**Note:** If the engine fails to start after 3 pulls, repeat steps 3 through 6.

## Stopping the Engine

1. Release the blade control bail and move the throttle control to the  (**Off**) position.
2. Disconnect the wire from the spark plug if you do not use the lawn mower or if you leave it unattended.

## Operating the Blade and the Self-Propel Drive

**Note:** The self-propel features are for the self-propel model only.

1. Have the blade control bail in the **A** position (Fig. 14).

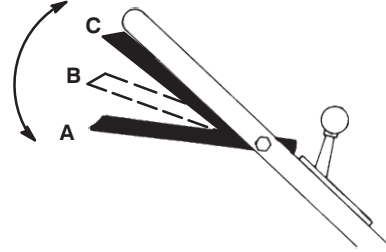



Figure 14

2. Slide the blade control bail to the right and raise it to the **B** position to engage the blade (Fig. 14).
3. Squeeze the blade control bail against the handle to the **C** position to drive (Fig. 14).

**Note:** To disengage the traction drive but keep the blade engaged, gradually release the blade control bail to the **B** position. To self-propel with the blade disengaged, squeeze the blade control bail against handle to the **C** position without sliding the blade control bail to the right.

The lawn mower has 3 ground speeds. **1** is slow, **2** is medium, and **3** is fast. The ground speed control is located at the rear of the belt cover (Fig. 13).

**Note:** You can vary the ground speed by increasing or decreasing the distance between the control bar and the handle. Lower the control bar to slow the lawn mower when making a turn or if the lawn mower is moving too fast for you. If you lower the control bar too far, the lawn mower stops self-propelling. Squeeze the control bar closer to the handle to increase the ground speed. When you hold the control bar tight against the handle, the lawn mower self-propels at the maximum ground speed. Move the ground speed control to the  (**Neutral**) position when you use the lawn mower for trimming and whenever you leave the lawn mower.

## Using the Discharge Tunnel Plug

1. Stop the engine and wait for all moving parts to stop.
2. Insert the plug; refer to Installing the Discharge Tunnel Plug on page 7.
3. To remove the plug, move the discharge door handle rearward and lift up the spring clip on the bottom of the plug. When the plug is unlocked, pull it out of the discharge tunnel.

**Note:** When grass is thick and lush, clippings may collect on and around the discharge tunnel plug. This may make removing the plug difficult. Clean the plug thoroughly after each use.

## Adjusting the Cutting Height

Each wheel is adjusted individually with a wheel height adjustment lever. Cutting heights are 1 inch (25 mm), 1-1/2 inches (38 mm), 2 inches (51 mm), 2-1/2 inches (64 mm), 3 inches (76 mm), and 3-1/2 inches (89 mm).

⚠
Danger
⚠

**Adjusting the cutting height levers could bring your hands into contact with a moving blade and result in serious injury.**

- **Stop the engine and wait for all movement to stop before adjusting the cutting height.**
- **Do not put your fingers under the housing when adjusting the cutting height.**

1. Pull the wheel height adjustment lever toward the wheel (Fig. 15) and move it to the desired setting.

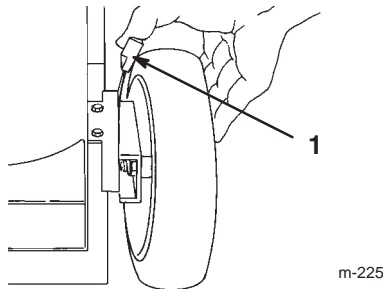

**Figure 15**

1. Wheel height adjustment lever
- 
2. Release the wheel height adjustment lever and seat it securely in the notch.
  3. Adjust all the wheels to the same cutting height setting.

## Using the Grass Bag

Occasionally, you may wish to use the grass bag for bagging extra long grass, lush grass, or leaves.

### Installing the Grass Bag

1. Stop the engine and wait for all moving parts to stop.
2. Ensure that the discharge door handle is fully forward and that the pin is engaged in the catch (Fig. 16).

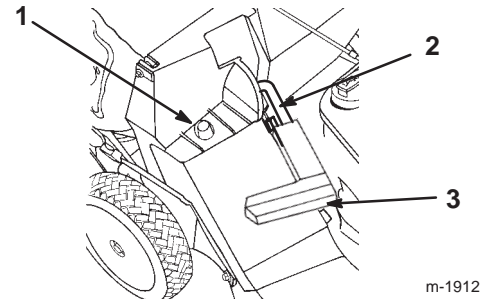

**Figure 16**

1. Bag frame on retaining post
  2. Pin engaged in catch
  3. Handle fully forward. Discharge door closed.
- 
3. Slide the hole in the bag frame onto the retaining post on the discharge tunnel (Fig. 16).
  4. Set the rear of the bag frame onto the bag support rod.
  5. Pull the discharge door handle forward until the pin clears the catch, and move the handle rearward until the pin locks in the bag notch (Fig. 17).

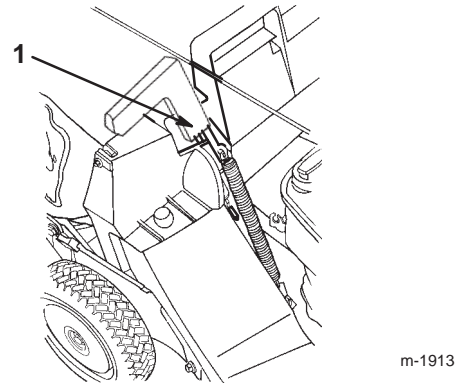

**Figure 17**

1. Pin locked in bag notch

**Note:** The discharge door in the lawn mower housing is now open.

## Mowing with the Grass Bag



### Warning



A worn grass bag could allow small stones and other similar debris to be thrown in the operator's or bystander's direction and result in serious personal injury or death to the operator or bystanders.

**Check the grass bag frequently. If it is damaged, install a new Toro replacement bag.**

Cut the grass until the bag is full.

**Important** Do not overfill the bag.

## Removing the Grass Bag

1. Stop the engine and wait for all moving parts to stop.
2. Raise the discharge door handle and move it forward to engage the pin with the catch (Fig. 16).
3. Grasp the handles at the front and the rear of the bag and lift the bag off the lawn mower.
4. Gradually tip the bag forward to empty the clippings.
5. To install the bag, refer to Installing the Grass Bag on page 11.



### Danger



**If the discharge door does not close completely, the lawn mower could throw objects, causing serious personal injury or death.**

**If you cannot close the door because the grass clippings clog the discharge area, stop the engine and gently move the discharge door handle back and forth until you can close the door completely. If you still cannot close the door, remove the obstruction with a stick, not your hand.**



### Danger



**The lawn mower can throw grass clippings and other objects through an open discharge tunnel. Objects thrown with enough force could cause serious personal injury or death to the operator or bystander.**

**Never open the door on the discharge tunnel when the engine is running.**

## Operating Tips

- Review the safety instructions and read this manual carefully before operating the lawn mower.
- Clear the area of sticks, stones, wire, branches, and other debris that the blade could hit and throw.
- Keep everyone, especially children and pets, away from the area of operation.
- Avoid striking trees, walls, curbs, or other solid objects. Never deliberately mow over any object.
- If the lawn mower strikes an object or starts to vibrate, immediately stop the engine, disconnect the wire from the spark plug, and examine the lawn mower for damage.
- Maintain a **sharp blade** throughout the cutting season. Periodically file down nicks on the blade.
- Replace the blade when necessary with an original Toro replacement blade.
- Mow only dry grass or leaves. Wet grass and leaves tend to clump on the yard and can cause the lawn mower to plug or the engine to stall.



### Warning



**Wet grass or leaves can cause serious injury if you slip and contact the blade.**

**Mow only in dry conditions.**

- Clean the underside of the lawn mower deck after each mowing. See Cleaning the Underside of the Lawn Mower Housing on page 15.
- Keep the engine in good running condition.
- Set the engine speed to the fastest position for the best cutting results.



### Warning



**Operating a lawn mower with its engine running at a speed greater than the factory setting can cause the lawn mower to throw a part of the blade or engine into the operator's or bystander's area and result in serious personal injury or death.**

- **Do not change the engine speed setting.**
- **If you suspect the engine speed is faster than normal, contact an Authorized Service Dealer.**

- Clean the air filter frequently. Mulching stirs up more clippings and dust which clogs the air filter and reduces engine performance.

## Cutting Grass

- Grass grows at different rates at different times of the year. In the summer heat, it is best to cut grass at the 2 inch (51 mm), 2-1/2 inch (64 mm), or 3 inch (76 mm) cutting height settings. Cut only about a third of the grass blade at a time. Do not cut below the 2 inch (51 mm) setting unless the grass is sparse or it is late fall when grass growth begins to slow down.
- When cutting grass over 6 inches (15 cm) tall, first mow at the highest cutting height setting and walk slower; then mow again at a lower setting for the best lawn appearance. If the grass is too long and the leaves clump on top of the lawn, the lawn mower may plug and cause the engine to stall.
- Alternate the mowing direction. This helps disperse the clippings over the lawn for even fertilization.

If the finished lawn appearance is unsatisfactory, try one or more of the following:

- Sharpen the blade.
- Walk at a slower pace while mowing.
- Raise the cutting height on your lawn mower.
- Cut the grass more frequently.
- Overlap cutting swaths instead of cutting a full swath with each pass.
- Set the cutting height on the front wheels one notch lower than the rear wheels. For example, set the front wheels at 2 inches (51 mm) and the rear wheels at 2-1/2 inches (64 mm).

## Cutting Leaves

- After cutting the lawn, ensure that half of the lawn shows through the cut leaf cover. You may need to make more than one pass over the leaves.
- For light leaf coverage, set all the wheels at the same cutting height setting.
- If there are more than 5 inches (12.7 cm) of leaves on the lawn, set the front cutting height 1 or 2 notches higher than the rear cutting height. This makes it easier to feed the leaves under the lawn mower deck.
- Slow down your mowing speed if the lawn mower does not cut the leaves finely enough.
- If you mow over oak leaves, you can add lime to the grass in the spring to reduce the acidity of the oak leaves.

# Maintenance

**Note:** Determine the left and right sides of the machine from the normal operating position.

## Recommended Maintenance Schedule

Maintenance Service Interval	Maintenance Procedure
Each Use	<ul style="list-style-type: none"> <li>• Check the engine oil level.</li> <li>• Check the stopping time of the blade brake. The blade must stop within 3 seconds of releasing the bail; if it does not, contact an Authorized Service Dealer for repair.</li> <li>• Remove grass clippings and dirt from under the housing.</li> <li>• Clean the discharge tunnel and the discharge tunnel plug.</li> </ul>
5 Hours	<ul style="list-style-type: none"> <li>• Check the blade and the engine mounting fasteners. Tighten them if they are loose.</li> </ul>
25 Hours	<ul style="list-style-type: none"> <li>• Clean the foam pre-cleaner of the air cleaner.</li> <li>• Lubricate the pivot arms (self-propel model only).</li> </ul>
50 Hours	<ul style="list-style-type: none"> <li>• Change the engine oil (without the oil filter).<sup>1</sup></li> <li>• Sharpen or replace the blade; maintain it more frequently if the edge dulls quickly in rough or in sandy conditions.</li> <li>• Check for leaks in the fuel system and/or a deteriorating fuel hose. Replace parts if necessary.</li> <li>• Remove grass clippings and debris from under the belt cover.</li> </ul>
75 Hours	<ul style="list-style-type: none"> <li>• Adjust the self-propel drive system (self-propel model only).</li> </ul>
100 Hours	<ul style="list-style-type: none"> <li>• Change the oil filter.</li> <li>• Inspect the spark plug and replace it if necessary.</li> <li>• Clean the paper air filter.</li> <li>• Clean the cooling system; remove grass clippings, debris, or dirt from the engine air cooling fins and starter. Clean the system more frequently in dirty or high-chaff conditions.</li> <li>• Clean the fuel filter.</li> <li>• Lubricate the gear case.</li> <li>• Adjust the blade brake cable.</li> <li>• Service the wheels.</li> </ul>
300 Hours	<ul style="list-style-type: none"> <li>• Replace the paper air filter. Replace it more frequently in dusty operating conditions.</li> </ul>
Storage	<ul style="list-style-type: none"> <li>• Empty the fuel tank before repairs as directed or before storage.</li> </ul>

<sup>1</sup>Change the engine oil after the first 8 operating hours.

**Important** Refer to your engine operator's manual for additional maintenance procedures.



## Caution



If you leave the wire on the spark plug, someone could accidentally start the engine and seriously injure you or other bystanders.

Disconnect the wire from the spark plug before you do any maintenance. Set the wire aside so that it does not accidentally contact the spark plug.

## Checking the Engine Oil Level

Before you use the lawn mower, make sure that the oil level is between the Add and the Full marks as shown on the dipstick (Fig. 8). If the oil level is below the Add mark, and oil. Refer to Filling the Crankcase with Oil on page 7.

## Cleaning the Underside of the Lawn Mower Housing

To ensure the best performance, keep the underside of the lawn mower housing clean. Be especially careful to keep the kickers free of debris (Fig. 18).

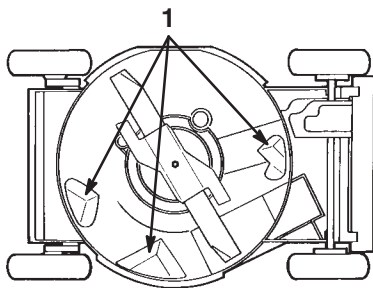

757

Figure 18

1. Kickers

### Washing Method

1. Position the lawn mower on a flat concrete or asphalt surface near a garden hose.
2. Start the engine.

3. Hold the running garden hose at handle level and direct the water to flow on the ground just in front of the right rear tire (Fig. 19).

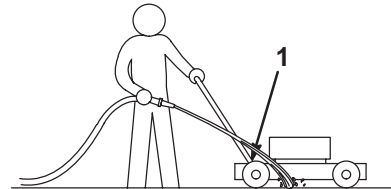

1093

Figure 19

1. Rear right wheel

**Note:** The blade will draw in water and wash out clippings. Let the water run until you no longer see clippings being washed out from under the housing.

4. Stop the engine and wait for all moving parts to stop.
5. Turn off the garden hose.
6. Start the lawn mower and let it run for a few minutes to dry out the moisture on the lawn mower and its components.

### Scraping Method

If washing does not remove all debris from under the lawn mower, scrape it clean.

1. Disconnect the wire from the spark plug (Fig. 12).
2. Drain the fuel from the fuel tank. Refer to Emptying the Fuel Tank and Cleaning the Fuel Filter on page 18.



## Warning



**Tipping the lawn mower may cause the fuel to leak from the carburetor or the fuel tank. Gasoline is extremely flammable, highly explosive, and, under certain conditions, can cause personal injury or property damage.**

**Avoid fuel spills by running the engine dry or by removing the gasoline with a hand pump; never siphon.**

3. Tip the lawn mower onto its **right** side (Fig. 18).

4. Remove the dirt and grass clippings with a hardwood scraper. Avoid burrs and sharp edges.
5. Turn the lawn mower upright.
6. Fill the fuel tank.
7. Connect the wire to the spark plug.

## Cleaning the Discharge Tunnel and Plug

Remove the plug from the discharge tunnel and clean it after each use.

Always be sure that the discharge tunnel door closes securely when you release the handle. If the debris prevents the discharge door from closing securely, clean the inside of the discharge tunnel and the door thoroughly.

⚠
Warning
⚠

**Grass clippings and other objects can be thrown from an open discharge tunnel and cause serious injury or kill the operator or bystanders.**

**Never start or operate the lawn mower unless *one* of the following is true:**

- **The discharge tunnel plug is locked securely in the discharge tunnel.**
- **The grass bag is locked in place.**
- **The optional side discharge chute is locked in place.**
- **The discharge tunnel door is locked in place.**

## Servicing the Air Filter

Clean the foam pre-cleaner every 25 operating hours. Clean the paper air filter every 100 operating hours. Replace the paper air filter once every season or every 300 operating hours; replace it more frequently in dusty conditions.

**Important** Do not operate the engine without the air filter assembly; extreme engine damage will occur.

1. Stop the engine and wait for all moving parts to stop.
2. Disconnect the wire from the spark plug (Fig. 12).

3. Remove the screw that secures the air cleaner cover (Fig. 20).

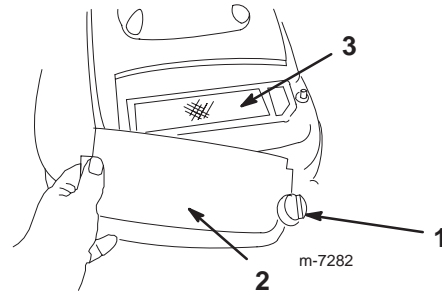

**Figure 20**

1. Screw
2. Cover
3. Paper air filter

4. Remove the cover and clean it thoroughly (Fig. 20).
5. Remove the paper air filter and discard it (Fig. 21).

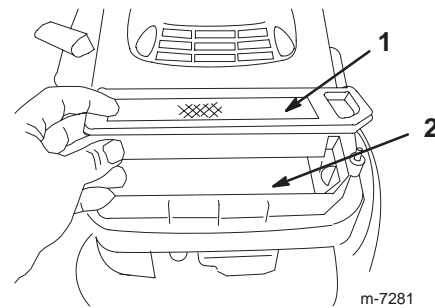

**Figure 21**

1. Paper air filter
2. Foam pre-cleaner

**Important** Do not try to clean a paper filter.

6. Remove the foam pre-cleaner and wash it with a mild detergent and water, then blot it dry (Fig. 20).
7. Saturate the pre-cleaner with clean engine oil, then squeeze it (do not twist) to remove the excess oil.
8. Install the foam pre-cleaner.
9. Install the new paper air filter.
10. Install the cover and secure it with the screw.

## Changing the Engine Oil

Change the oil after the first **8** operating hours and then after every 50 operating hours or every season (more frequently in dusty or dirty conditions).

1. Run the engine to warm the engine oil.

**Note:** Warm oil flows better and carries more contaminants.

**Warning**

**Oil may be hot after engine has been run, and contact with hot oil can cause severe personal injury.**

**Avoid contacting the hot engine oil when you drain it.**

2. Stop the engine and wait for all moving parts to stop.
3. Disconnect the wire from the spark plug (Fig. 12).
4. Place a suitable drain pan beside the right side of the lawn mower.
5. Remove the dipstick by rotating the cap counterclockwise and pulling it out (Fig. 8).
6. Raise the left side of the lawn mower to drain the oil into the drain pan.  
**Note:** You can also remove the oil from the crankcase using an oil extractor.
7. Lower the left side of the lawn mower.
8. Insert the dipstick into the filler neck and rotate the cap clockwise until it is tight.
9. Recycle the used oil according to local codes.
10. Fill the crankcase to the Full line on the dipstick with fresh oil. Refer to the Filling the Crankcase with Oil on page 7.

11. Wipe up any spilled oil.

## Maintaining the Cutting Blade

Always mow with a sharp blade. A sharp blade cuts cleanly and without tearing or shredding the grass blades.

1. Stop the engine and wait for all moving parts to stop.
2. Disconnect the wire from the spark plug (Fig. 12).
3. Drain the gasoline from the fuel tank; refer to Emptying the Fuel Tank and Cleaning the Fuel Filter on page 18.
4. Tip the lawn mower onto its **right** side (Fig. 22).

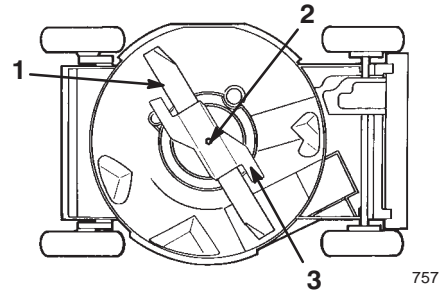
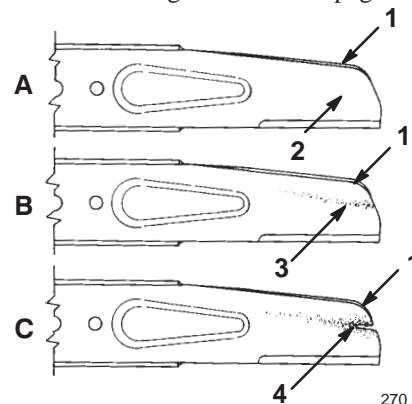

**Figure 22**

- |                               |                |
|-------------------------------|----------------|
| 1. Blade                      | 3. Accelerator |
| 2. Blade bolt and lock washer |                |

## Inspecting the Blade

Carefully examine the blade for sharpness and wear, especially where the flat and the curved parts meet (Fig. 23A). Because sand and abrasive material can wear away the metal that connects the flat and curved parts of the blade, check the blade before using the lawn mower. If you notice a slot or wear (Figs. 23B and 23C), replace the blade; refer to Removing the Blade on page 18.



**Figure 23**

- |                       |                |
|-----------------------|----------------|
| 1. Sail               | 3. Wear        |
| 2. Flat part of blade | 4. Slot formed |

**Note:** For the best performance, install a new blade before the cutting season begins. During the year, file down any small nicks to maintain the cutting edge.

! **Danger** !

**A worn or damaged blade can break, and a piece of the blade could be thrown into the operator's or bystander's area, resulting in serious personal injury or death.**

- Inspect the blade periodically for wear or damage.
- Replace a worn or damaged blade.

## Removing the Blade

1. Grasp the end of the blade using a rag or a thickly padded glove.
2. Remove the blade bolt, the lock washer, the accelerator, and the blade (Fig. 22).

## Sharpening the Blade

File the top side of the blade to maintain its original cutting angle (Fig. 24A) and inner cutting edge radius (Fig. 24B). The blade will remain balanced if you remove the same amount of material from both cutting edges.

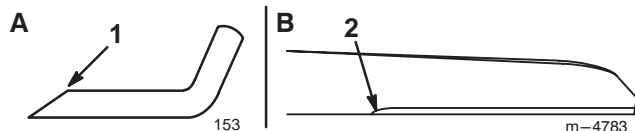
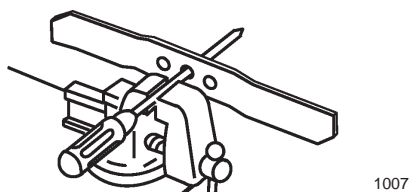

**Figure 24**

1. Sharpen at this angle only
2. Maintain the original radius here

## Balancing the Blade

1. Check the balance of the blade by placing the center hole of the blade over a nail or screwdriver shank clamped horizontally in a vise (Fig. 25).



**Figure 25**

**Note:** You can also check the balance using a commercially manufactured blade balancer.

2. If either end of the blade rotates downward, file that end (not the cutting edge or the end near the cutting edge). The blade is properly balanced when neither end drops.

## Installing the Blade

1. Install a sharp, balanced Toro blade, the accelerator, the lock washer, and the blade bolt. The sail of the blade must point toward the top of the lawn mower housing for proper installation. Torque the blade nuts to 50 ft-lb (68 N·m).

! **Warning** !

**Operating the lawn mower without the accelerator in place can cause the blade to flex, bend, or break, resulting in serious injury or death to the operator or bystanders.**

**Do not operate the lawn mower without the accelerator.**

2. Return the lawn mower to its upright position.
3. Connect the wire to the spark plug.

## Emptying the Fuel Tank and Cleaning the Fuel Filter

The fuel filter (screen) element is located inside the fuel tank. Clean the fuel filter element every 100 operating hours.

1. Stop the engine and wait for it to cool down.

**Important** Drain gasoline from a cold engine only.

2. Disconnect the wire from the spark plug (Fig. 12).
3. Close the fuel valve (Fig. 5).
4. Disconnect the fuel line (Fig. 31) by loosening the tube clamp at the carburetor.
5. Open the fuel valve.
6. Drain the gasoline completely from the tank and fuel line into an approved fuel container.
7. Remove the fuel tank from the mower.
8. Close the fuel valve.
9. Pour a small amount of fuel in the fuel tank, move the fuel around in the tank, and pour it out into an approved fuel container.
10. Install the fuel tank and fuel line; refer to Installing the Fuel Tank and the Fuel Line on page 6.

## Cleaning under the Belt Cover

### Self-propel Model only

Keep the area under the belt cover free of debris.

1. Stop the engine and wait for all moving parts to stop.
2. Remove the bolts that secure the belt cover (Fig. 26) to the lawn mower housing.

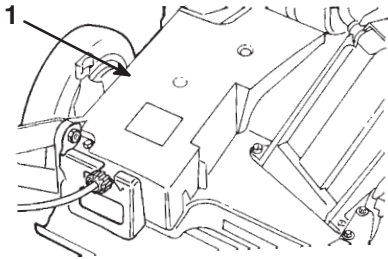

m-224

**Figure 26**

1. Belt cover
- 

3. Lift off the cover and brush out all the debris around the belt area.
4. Install the belt cover.

## Lubricating the Pivot Arms

### Self-propel Model only

After every 25 operating hours or when the season ends, lubricate the pivot arms.

1. Move the rear wheel cutting height levers to the center setting.
2. Wipe the grease fittings with a clean rag (Fig. 27).

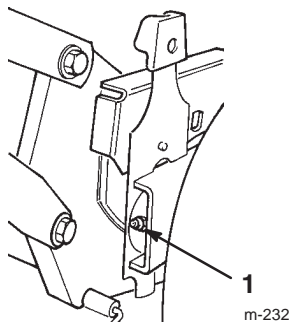

m-232

**Figure 27**

1. Grease fitting
- 

3. Install a grease gun onto the fitting and gently apply 2 or 3 pumps of #2 multi-purpose lithium base grease (Fig. 27).

**Note:** Excessive grease pressure may damage the seals.

## Adjusting the Self-propel Drive

### Self-propel Model only

If the lawn mower does not self-propel or has a tendency to creep forward when the control bar is **more** than 1-1/2 inches (3.8 cm) from the handle, adjust the wheel drive control knob on the rear of the gear box.

1. Close the door in the lawn mower housing and remove the grass bag.
2. Rotate the control knob clockwise 1/2 turn if the lawn mower does not self-propel. If the lawn mower creeps forward, rotate the knob 1/2 turn counterclockwise to loosen the belt (Fig. 28).

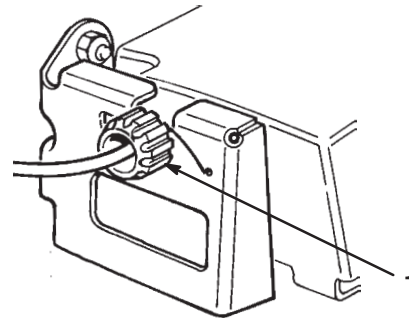

m-228

**Figure 28**

1. Control knob
- 

3. Slowly pull the lawn mower backward while you gradually move the control bar toward the handle.

**Note:** The adjustment is correct when the rear wheels stop turning and the control bar is about one inch (2.5 cm) from the handle (Fig. 29).

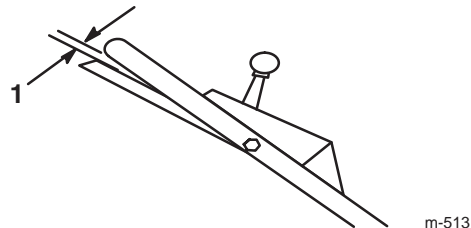

m-513

**Figure 29**

1. One inch (2.5 cm)
-

## Servicing the Spark Plug

Check the spark plug after every 100 operating hours. Use an **NGK BPR5ES** spark plug or equivalent.

1. Stop the engine and wait for all moving parts to stop.
2. Disconnect the wire from the spark plug (Fig. 12).
3. Clean around the spark plug.
4. Remove the spark plug from the cylinder head.

**Important** Replace a cracked, fouled, or dirty spark plug. Do not clean the electrodes because grit entering the cylinder can damage the engine.

5. Set the gap on the plug to 0.030 in. (0.76 mm) (Fig. 30).

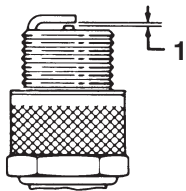

m-110

**Figure 30**

1. 0.030 in. (0.76 mm)

6. Install the spark plug and the gasket seal.
7. Torque the plug to 17 ft-lb (23 N·m).
8. Connect the wire to the spark plug.

## Changing the Oil Filter

Replace the oil filter (Fig. 31) after every 100 operating hours or yearly, whichever comes first.

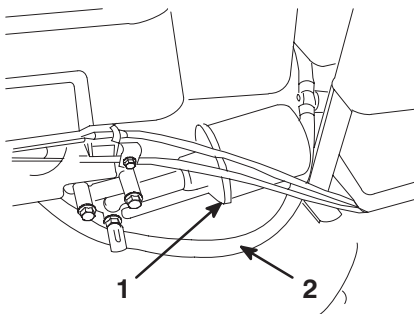

m-7284

**Figure 31**

1. Oil filter
2. Fuel line

1. Run the engine to warm the oil.



### Warning



**Oil may be hot after the engine has been run, and contact with hot oil can cause severe personal injury.**

**Avoid contacting the hot engine oil when you drain it.**

2. Stop the engine and wait for all moving parts to stop.
3. Disconnect the wire from the spark plug (Fig. 12).
4. Drain the engine oil; refer to Changing the Engine Oil on page 17.
5. Place a rag under the oil filter to catch any oil that may leak out as you remove the filter.
6. Remove the oil filter.
7. Use your finger to coat the gasket on the new filter with clean engine oil (Fig. 32).

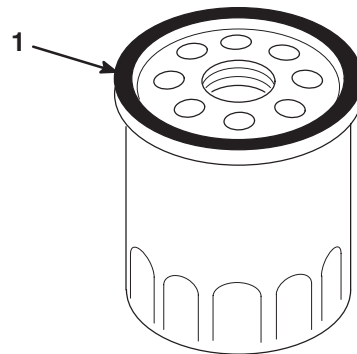

m-3862

**Figure 32**

1. Gasket
8. Install the new filter and hand tighten it 2/3 turn only.
9. Fill the crankcase to the Full line on the dipstick with fresh oil. Refer to Filling the Crankcase with Oil on page 7.
10. Connect the wire to the spark plug.
11. Run the engine for about 3 minutes.
12. Stop the engine, wait for all moving parts to stop, and check for oil leakage around the filter.
13. Add oil to compensate for the oil in the oil filter. Refer to Checking the Engine Oil Level on page 15.
14. Recycle the used oil filter according to local codes.

# Lubricating the Gear Case

After every 100 operating hours, grease the gear case.

1. Remove the grass bag.
2. Install a grease gun onto the fitting through the belt cover opening (Fig. 33).

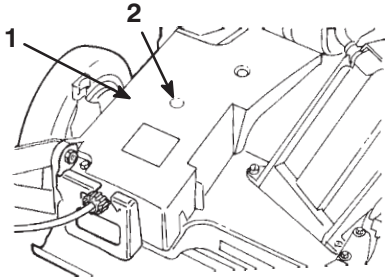

**Figure 33**

1. Belt cover
2. Grease fitting

3. Gently apply one to 2 pumps of #2 multi-purpose lithium-base grease.
4. Install the grass bag.

# Adjusting the Blade Brake Cable

Whenever you install a new blade brake cable assembly, adjust it.

1. Stop the engine and wait for all moving parts to stop.
2. Disconnect the wire from the spark plug (Fig. 9).
3. Check the adjustment of the cable by moving the control bar toward the handle until you remove the slack in the cable.

**Note:** The gap between the brake lever and the handle must be between 3/16 and 1/4 in. (5 and 6 mm). To adjust the cable, go to step 4.

4. To adjust the cable, do the following:

## Hand-push Model only

- A. Loosen the jam nut on the blade brake cable (Fig. 34).

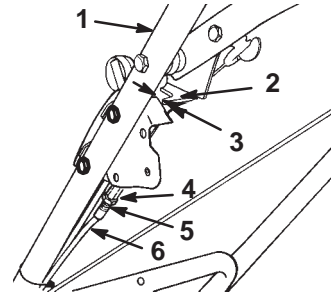

**Figure 34**

1. Handle
2. Brake lever
3. 3/16 to 1/4 in. (5 to 6 mm)
4. Cable adjuster
5. Jam nut
6. cable conduit

- B. Insert a 3/16 to 1/4 in. (5 to 6 mm) object between the brake lever and the handle.
- C. Turn the cable adjuster on the brake cable until you remove the slack.
- D. Tighten the jam nut.

## Self-propel Model only

- A. Loosen the nut on the cable bracket (Fig. 35).

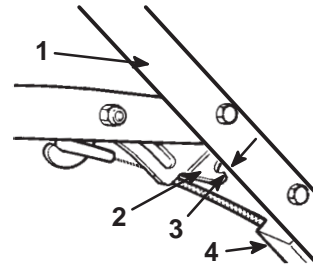

**Figure 35**

1. Handle
2. Brake lever
3. 3/16 to 1/4 in. (5 to 6 mm)
4. cable bracket

- B. Insert a 3/16 to 1/4 in. (5 to 6 mm) object between the brake lever and the handle.
- C. Pull down on the cable conduit until you remove the slack from the wire.
- D. Tighten the nut.

483

m-224

# Servicing the Wheels

## Removing the Wheels

1. Stop the engine and wait for all moving parts to stop.
2. Disconnect the wire from the spark plug (Fig. 12).
3. Remove the cap screw, the wheel spacer, and the locknut mounting the wheel to the pivot arm (Fig. 36).

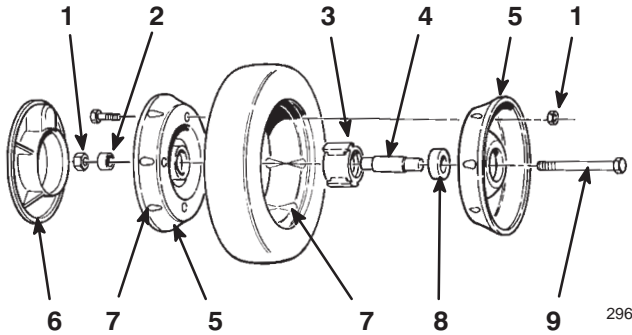

Figure 36

- |                         |                                     |
|-------------------------|-------------------------------------|
| 1. Locknuts             | 6. Plastic cover (rear wheels only) |
| 2. Wheel spacer         | 7. Lug                              |
| 3. Bearing/hub assembly | 8. Bearing (2)                      |
| 4. Bearing spacer       | 9. Cap screw                        |
| 5. Wheel half           |                                     |

4. Separate the wheel halves from the tire by removing 4 cap screws and 4 locknuts (Fig. 36).

**Note:** If you remove the bearings from the bearing/hub assembly, remove them by pressing on the bearing spacer (Fig. 36).

## Assembling the Wheels

1. Position the tire onto one wheel half, aligning the lugs on each (Fig. 36).
2. Place the bearing/hub assembly into the center hole of the wheel half. Ensure that the legs of the hub are positioned over the flange of the hole (Fig. 36).
3. Place the other wheel half onto the bearing/hub assembly, aligning the wheel and the tire lugs and the mounting holes (Fig. 36).
4. Using 2 fully threaded screws or bolts (1/4–20 x 1.50 in.) and non-locking nuts, loosely secure the wheel halves together. Mount the screws or bolts in the opposing holes (Fig. 36).
5. Check the alignment of all parts and tighten the screws, alternating from side to side for a uniform fit, until the wheel halves are drawn together (Fig. 36).

6. Install the 2 cap screws and 2 locknuts previously removed in the remaining holes in the wheel halves and tighten. Remove the 2 long screws or bolts and replace them with 2 cap screws and 2 locknuts (Fig. 36).
7. Install the wheel to the pivot arm with the cap screws, a spacer, and a locknut. Ensure that the spacer is positioned between the wheel hub and the pivot arm (Fig. 36).

# Storage

To prepare the lawn mower for off-season storage, perform the recommended maintenance procedures. Refer to Maintenance on page 14.

Store the lawn mower in a cool, clean, dry place. Cover the lawn mower to keep it clean and protected.

## Preparing the Fuel System



### Warning



**Gasoline can vaporize if you store it over long periods of time and explode if it comes into contact with an open flame.**

- Do not store gasoline over long periods of time.
- Do not store the lawn mower with gasoline in the fuel tank or the carburetor in an enclosure with an open flame. (For example, a furnace or a water heater pilot light.)
- Allow the engine to cool before storing it in any enclosure.

Empty the fuel tank when mowing the last time before storing the lawn mower.

1. Run the lawn mower until the engine stops from running out of fuel.
2. Prime the engine and start it again.
3. Allow the engine to run until it stops. When you can no longer start the engine, it is sufficiently dry.

## Preparing the Engine

1. While the engine is still warm, change the oil from the crankcase. Refer to Changing the Engine Oil on page 17.
2. Remove the spark plug (Fig. 12).
3. Using an oil can, add about one tablespoon of oil to the crankcase through the spark plug hole.
4. Slowly rotate the engine several times, using the starter rope, to distribute the oil.
5. Install the spark plug but **do not** connect the wire to the spark plug.

## General Information

1. Clean the lawn mower housing. Refer to Cleaning the Underside of the Lawn Mower Housing on page 15.
2. Clean any dirt and chaff from the cylinder, cylinder head fins, and blower housing.
3. Remove grass clippings, dirt, and grime from the external parts of the engine, the shrouding, and the top of the lawn mower housing.
4. Check the condition of the blade. Refer to Maintaining the Cutting Blade on page 17.
5. Service the air filter; refer to Servicing the Air Filter on page 16.
6. Lubricate the pivot arms; refer to Lubricating the Pivot Arms on page 16.
7. Tighten all nuts, bolts, and screws.
8. Touch up all rusted or chipped paint surfaces with paint available from an Authorized Service Dealer.

## Removing the Lawn Mower from Storage

1. Check and tighten all fasteners.
2. Remove the spark plug and spin the engine rapidly using the starter to blow excess oil from the cylinder.
3. Clean the spark plug or replace it if it is cracked, broken, or if the electrodes are worn.
4. Install the spark plug and torque it to 17 ft-lb (23 N·m).
5. Perform any needed maintenance procedures; refer to Maintenance on page 14.
6. Fill the fuel in the fuel tank with fresh gasoline.
7. Check the engine oil level.
8. Connect the wire to the spark plug.

## Accessories

You may purchase the following accessories from an Authorized Service Dealer:

- Side Discharge Kit
- Atomic Blade

# Troubleshooting

Toro designed and built your lawn mower for trouble-free operation. Check the following components and items carefully, and refer to Maintenance on page 14 for more information. If a problem continues, contact an Authorized Service Dealer.

Problem	Possible Causes	Corrective Action
Engine does not start	<ol style="list-style-type: none"> <li>1. The fuel tank is empty or the fuel system contains stale fuel.</li> <li>2. The throttle lever is not in the <b>Choke</b> position.</li> <li>3. The wire is not connected to the spark plug.</li> <li>4. The spark plug is pitted, fouled, or the gap is incorrect.</li> </ol>	<ol style="list-style-type: none"> <li>1. Drain and/or fill the fuel tank with fresh gasoline. If the problem persists, contact an Authorized Service Dealer.</li> <li>2. Move the throttle lever to the <b>Choke</b> position.</li> <li>3. Connect the wire to the spark plug.</li> <li>4. Check the spark plug and adjust the gap if necessary. Replace the spark plug if it is pitted, fouled, or cracked.</li> </ol>
Engine starts hard or loses power	<ol style="list-style-type: none"> <li>1. The fuel tank contains stale fuel.</li> <li>2. The fuel cap vent hole is plugged.</li> <li>3. The air filter element is dirty and is restricting the air flow.</li> <li>4. The underside of the lawn mower deck contains clippings and debris.</li> <li>5. The spark plug is pitted, fouled, or the gap is incorrect.</li> <li>6. The engine oil level is low or the oil is dirty.</li> </ol>	<ol style="list-style-type: none"> <li>1. Drain and fill the fuel tank with fresh gasoline.</li> <li>2. Clean the fuel cap vent hole or replace the fuel cap.</li> <li>3. Clean the air filter pre-cleaner and/or replace the paper air filter.</li> <li>4. Clean the underside of the lawn mower deck.</li> <li>5. Check the spark plug and adjust the gap if necessary. Replace the spark plug if it is pitted, fouled, or cracked.</li> <li>6. Check the engine oil. Change the oil if it is dirty or add oil if it is low.</li> </ol>
Engine runs rough	<ol style="list-style-type: none"> <li>1. The wire is not connected to the spark plug.</li> <li>2. The spark plug is pitted, fouled, or the gap is incorrect.</li> <li>3. The throttle lever is not in the <b>Fast</b> position.</li> <li>4. The air filter element is dirty and is restricting the air flow.</li> </ol>	<ol style="list-style-type: none"> <li>1. Connect the wire to the spark plug.</li> <li>2. Check the spark plug and adjust the gap if necessary. Replace the spark plug if it is pitted, fouled, or cracked.</li> <li>3. Move the throttle lever to the <b>Fast</b> position.</li> <li>4. Clean the air filter pre-cleaner and/or replace the paper air filter.</li> </ol>

Problem	Possible Causes	Corrective Action
Lawn mower or engine vibrates excessively	<ol style="list-style-type: none"> <li>1. The blade is bent or is out of balance.</li> <li>2. The blade mounting bolt is loose.</li> <li>3. The underside of the lawn mower deck contains clippings and debris.</li> <li>4. The engine mounting bolts are loose.</li> </ol>	<ol style="list-style-type: none"> <li>1. Balance the blade. If the blade is bent, replace it.</li> <li>2. Tighten the blade mounting bolt.</li> <li>3. Clean the underside of the lawn mower deck.</li> <li>4. Tighten the engine mounting bolts.</li> </ol>
Uneven cutting pattern	<ol style="list-style-type: none"> <li>1. All 4 wheels are not at the same height.</li> <li>2. The blade is dull.</li> <li>3. You are mowing in the same pattern repeatedly.</li> <li>4. The underside of the lawn mower deck contains clippings and debris.</li> </ol>	<ol style="list-style-type: none"> <li>1. Place all 4 wheels at the same height.</li> <li>2. Sharpen and balance the blade.</li> <li>3. Change the mowing pattern.</li> <li>4. Clean the underside of the lawn mower deck.</li> </ol>
Discharge chute plugs	<ol style="list-style-type: none"> <li>1. The throttle lever is not in the <b>Fast</b> position.</li> <li>2. The cutting height is too low.</li> <li>3. You are mowing too fast.</li> <li>4. The grass is wet.</li> <li>5. The underside of the lawn mower deck contains clippings and debris.</li> </ol>	<ol style="list-style-type: none"> <li>1. Move the throttle lever to the <b>Fast</b> position.</li> <li>2. Raise the cutting height.</li> <li>3. Slow down.</li> <li>4. Allow the grass to dry before mowing.</li> <li>5. Clean the underside of the lawn mower deck.</li> </ol>
Lawn mower does not self-propel (self-propel model only)	<ol style="list-style-type: none"> <li>1. The self-propel drive cable is out of adjustment or is damaged.</li> <li>2. There is debris under the belt cover.</li> </ol>	<ol style="list-style-type: none"> <li>1. Adjust the self-propel drive cable. Replace the cable if necessary.</li> <li>2. Clean the debris from under the belt cover.</li> </ol>







Gas, Cordless,  
Electric, and 21"  
Commercial Duty  
Walk Mowers

## The Toro Total Coverage Guarantee

### A Full Warranty

(Limited Warranty for Commercial Use)

#### Conditions and Products Covered

The Toro Company and its affiliate, Toro Warranty Company, pursuant to an agreement between them, jointly promise to repair any Toro Product used for normal residential purposes\* if defective in materials or workmanship or if it stops functioning due to the failure of a component. The following time periods apply from the date of purchase:

<u>Products</u>	<u>Warranty Period</u>
• Super Recycler® Walk Mowers	5 year full warranty
• VacuPower® Walk Mowers	5 year full warranty
• All Other Mowers	2 year full warranty
• All Batteries	1 year full warranty

This warranty includes the cost of parts and labor, but you must pay transportation costs.

This warranty applies to all gas, cordless, and electric consumer walk power mowers.

\* Normal residential purposes means use of the product on the same lot as your home. Use at more than one location is considered commercial use, and the commercial use warranty would apply.

#### Limited Warranty for Commercial Use

Toro Walk Power Mowers used for commercial, institutional, or rental use are warranted against defects in materials or workmanship. Components failing due to normal wear are not covered by this warranty. The following time periods apply from the date of purchase:

<u>Products</u>	<u>Warranty Period</u>	
	<u>Engine</u>	<u>Entire Unit</u>
• 21" Commercial Duty Walk Mowers	2 year limited	1 year limited
• All Other Mowers	45 day limited	45 day limited

#### Instructions for Obtaining Warranty Service

Should you feel your Toro Product contains a defect in materials or workmanship, contact the dealer who sold you the product or any Authorized Service Dealer or Master Service Dealer. The Yellow Pages of your telephone directory is a good reference source. The dealer will either arrange service at his/her dealership or recommend another Authorized Service Dealer who may be more convenient. You may need proof of purchase (copy of registration card, sales receipt, etc.) for warranty validation.

If for any reason you are dissatisfied with the Service Dealer's analysis of the defect in materials or workmanship or if you need a referral to a Toro Service Dealer, please feel free to contact us at:

Customer Service Department  
Toro Warranty Company  
8111 Lyndale Avenue South  
Bloomington, MN 55420-1196  
952-888-8801 or 800-421-9684

#### Countries Other than the United States or Canada

Customers who have purchased Toro products exported from the United States or Canada should contact their Toro Distributor (Dealer) to obtain guarantee policies for your country, province, or state. If for any reason you are dissatisfied with your Distributor's service or have difficulty obtaining guarantee information, contact the Toro importer. If all other remedies fail, you may contact us at Toro Warranty Company.

#### Owner Responsibilities

You must maintain your Toro Product by following the maintenance procedures described in the operator's manual. Such routine maintenance, whether performed by a dealer or by you, is at your expense.

#### Items and Conditions Not Covered

There is no other express warranty except for special emission system coverage on some products and the Toro Starting Guarantee on GTS Engine. This express warranty does not cover:

- Cost of regular maintenance service or parts, such as filters, fuel, lubricants, oil changes, spark plugs, blade sharpening, worn blade, cable/linkage adjustments, or brake and clutch adjustments.
- Any product or part which has been altered or misused or required replacement or repair due to accidents or lack of proper maintenance.
- Repairs necessary due to improper fuel, contaminants in the fuel system, or failure to properly prepare the fuel system prior to any period of non-use over three months.
- Repairs necessary due to improper battery care, electrical supply irregularities, or failure to properly prepare the mower prior to any period of non-use.
- Pickup and delivery charges.

All repairs covered by this warranty must be performed by an Authorized Toro Service Dealer using Toro approved replacement parts.

#### General Conditions

Repair by an Authorized Toro Service Dealer is your sole remedy under this warranty.

Neither The Toro Company nor Toro Warranty Company is liable for indirect, incidental or consequential damages in connection with the use of the Toro Products covered by this warranty, including any cost or expense of providing substitute equipment or service during reasonable periods of malfunction or non-use pending completion of repairs under this warranty. Some states do not allow exclusions of incidental or consequential damages, or limitations on how long an implied warranty lasts, so the above exclusions and limitations may not apply to you.

This warranty gives you specific legal rights, and you may also have other rights which vary from state to state.