



NA Charger Connector Kit

Groundsmaster® e3200 or e3300 Traction Unit

Model No. 161-5100

Installation Instructions

Installation

Loose Parts

Use the chart below to verify that all parts have been shipped.

Procedure	Description	Qty.	Use
1	No parts required	–	Prepare the machine.
2	No parts required	–	Remove the existing charger connector.
3	Charger connector Connector plate Screw (5/16 inch)	1 1 2	Install the charger connector.
4	No parts required	–	Adjust the charger configuration setting in Toro DIAG.

1

Preparing the Machine

No Parts Required

Procedure

1. Park the machine on a level surface.
2. Ensure that the parking brake is engaged.
3. Shut off the machine and remove the key.
4. Turn the battery-disconnect switch to the OFF position.

2

Removing the Existing Charger Connector

No Parts Required

Procedure

1. Remove the bolts and screws that secure the cover to the left side of the machine ([Figure 1](#)) and remove the cover.



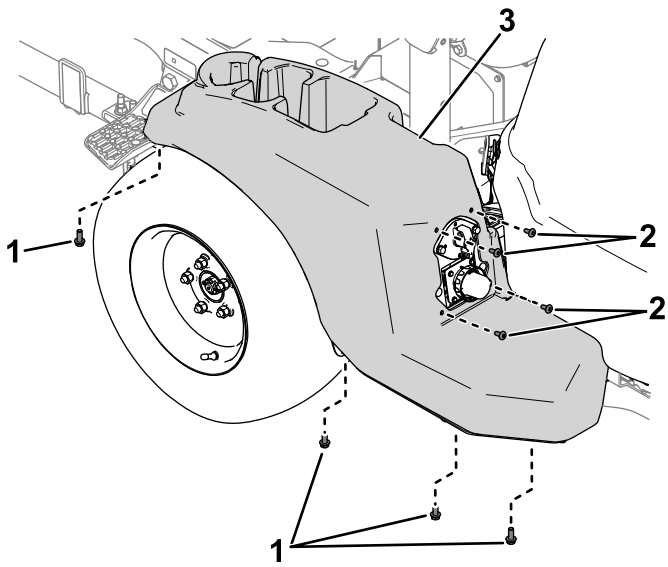

Figure 1

g515696

- 1. Bolts
- 2. Screws
- 3. Cover

3

Installing the Charger Connector

Parts needed for this procedure:

1	Charger connector
1	Connector plate
2	Screw (5/16 inch)

Procedure

1. Use 2 screws (5/16 inch) and the existing screws, washers, and nuts on the charger connector to secure the connector and connector plate to the frame panel (Figure 3).

2. Remove the hardware that secures the charger connector and connector plate to the frame panel (Figure 2).

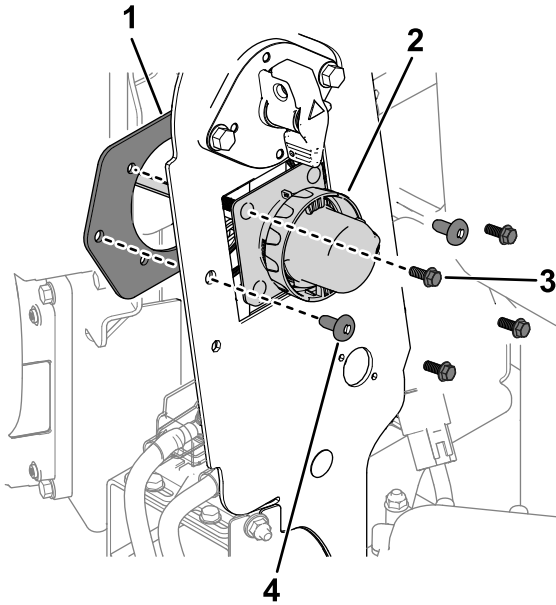

Figure 2

g515709

- 1. Connector plate
- 2. Charger connector
- 3. Bolt
- 4. Screw

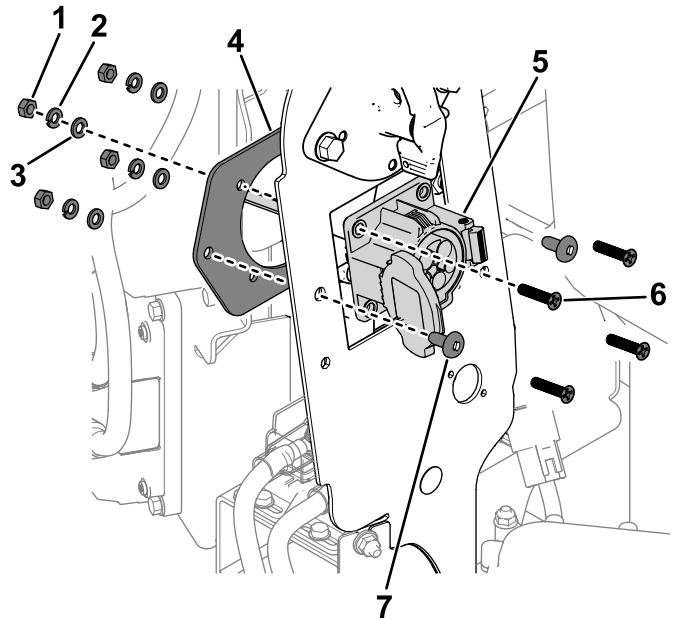

Figure 3

g586073

- 1. Nut
- 2. Flat washer
- 3. Lock washer
- 4. Connector plate
- 5. Charger connector
- 6. Screw
- 7. Screw (5/16 inch)

3. Unplug the charger connector from the charger-wire-harness connector and remove the charger connector from the machine.

2. Install the wire-harness connectors for the charger connector as follows:
 - Connector labeled **P02**: Connect to the machine-wire-harness connector labeled P31 (CHARGER PORT INTERCONNECT).
 - Connector labeled **P03**: Connect to the AC-inlet connector labeled P02 (AC CHARGE PORT).
3. Use the previously removed screws and bolts to secure the cover to the left side of the machine ([Figure 4](#)).

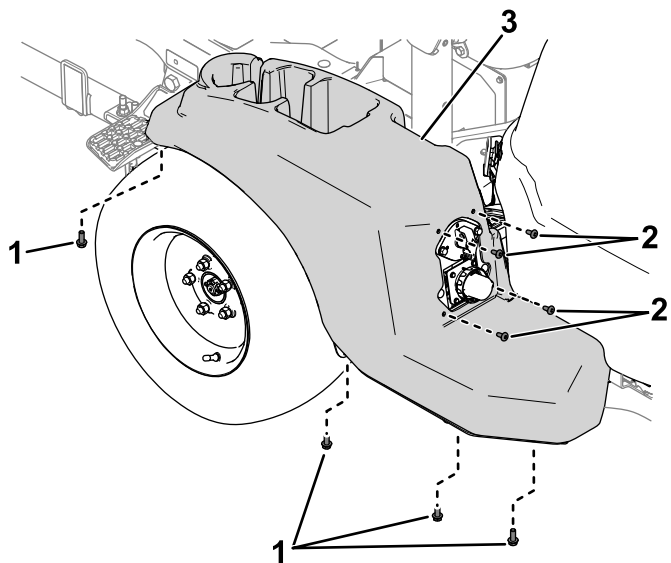

Figure 4

g515696

- | | |
|-----------|----------|
| 1. Bolts | 3. Cover |
| 2. Screws | |

4

Adjusting the Charger Configuration Setting in Toro DIAG

No Parts Required

Procedure

1. Turn the battery-disconnect switch to the ON position.
2. Connect the machine to Toro DIAG; refer to the Toro DIAG Commercial Product *User's Guide*.
3. Within the **Controllers** tab, select the **T1:Primary** option.
4. Within the **Configuration** tab in the T1:Primary screen, select **Charger Configuration**.
5. The **Charger Configuration** window appears. Select the **EVSE North America (J1772)** option (Figure 5).

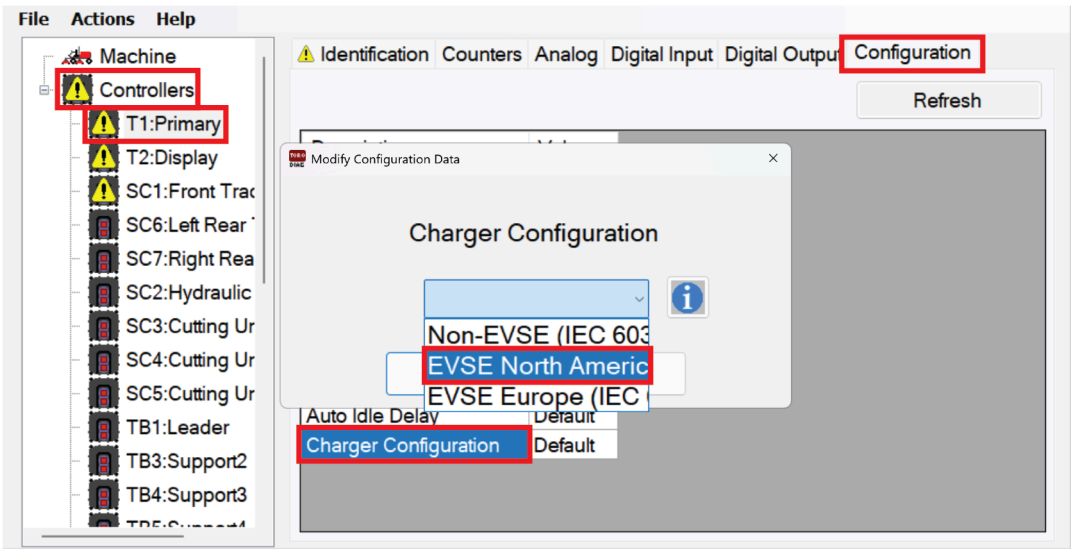

Figure 5

g586052

-
6. Rotate the key switch to the OFF position and close Toro DIAG.