



**Count on it.**

**Parts Catalog**

**SGR-6 Stump Grinder**

Model No. 22600—Serial No. 420000000 and Up



# Ordering Replacement Parts

To order replacement parts, please supply the part number, the quantity, and the description of each part desired.

## Understanding Reference Numbers

Each identified part in an illustration has a reference number. The reference number for a part also appears in the parts list, along with other information about the part.

This catalog uses two special reference number formats, one to indicate parts in a service assembly and another to indicate the quantity of a given part in an illustration.

## Service Assembly Reference Numbers

Parts in service assemblies have reference numbers in the form a:b. The a represents the reference number of the entire service assembly and the b represents a sequential number unique to each part within the service assembly.

For example, a wheel assembly might be identified by reference number 6, the tire by 6:1, the valve by 6:2, and the wheel by 6:3. When you order the assembly identified by reference number 6, you receive all parts identified by reference numbers 6:1, 6:2, and 6:3. However, you may also order any part individually. Reference numbers of this type appear in illustration and in parts lists.

## Reference Numbers Indicating Quantity

In an illustration, if a reference number indicates more than one part, the reference number has the form nX y. The n represents the quantity of the part, the X is the multiplication symbol, and the y represents the reference number.

For example, in an illustration, the reference number 2X 37 means that two of the parts identified by reference number 37 are indicated.

# Contents

- Engine and Frame Assembly ..... 4
- Handle Assembly ..... 6
- 3-Tooth Grinder Wheel Assembly ..... 8
- Brake and Wheel Assembly ..... 10
- Flap Assembly ..... 12
- Drive Belt Assembly ..... 14
- Attachments and Accessories ..... 16

# Engine and Frame Assembly

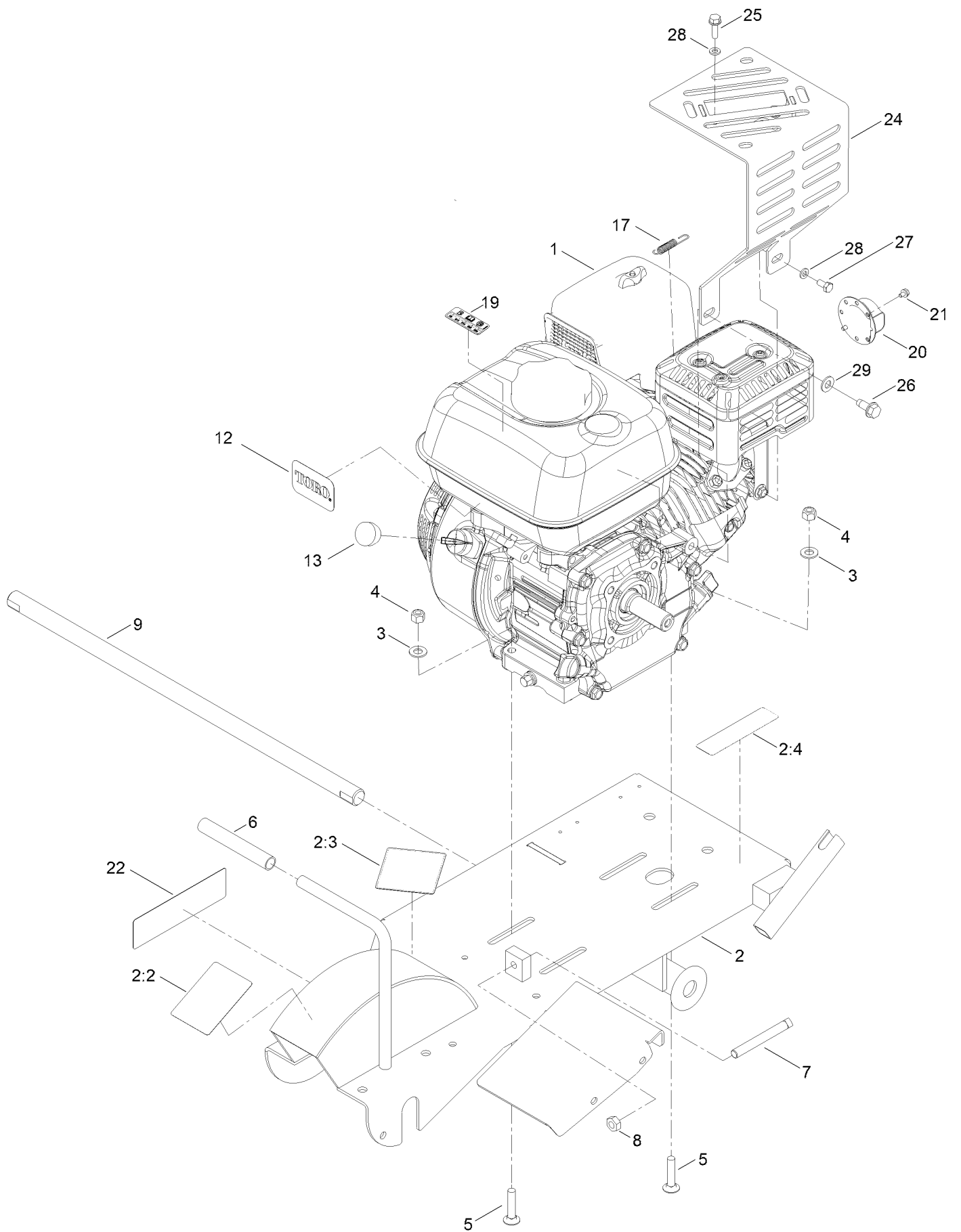

## Engine and Frame Assembly (continued)

<i>Ref.</i>	<i>Part Number</i>	<i>Qty.</i>	<i>Description</i>	<i>Ref.</i>	<i>Part Number</i>	<i>Qty.</i>	<i>Description</i>
1		1	Engine-Honda, Gx200 ●■	13	120-1887	1	Plug-Engine
2	132-3965	1	Frame ASM	17	119-4609	1	Spring-Extension
2:2	119-4693	1	Decal-Caution	19	130-8322	1	Decal-Warning, Ethanol
2:3	119-4690	1	Decal-Danger	20	125-3866	1	Deflector
2:4	133-8062	1	Decal-Spark Arrestor	21	127-7578	1	Screw-HWH
3	3256-45	4	Washer-Flat	22	132-4004	1	Decal-Rotate Tooth
4	3296-29	4	Nut-Lock, NI	24	137-4867-05	1	Guard- Muffler [blk-Txt]
5	3230-4	4	Screw-CARR	25	110-3986	2	Screw
6	112-2605	1	Grip-Rubber	26	32144-70	1	Screw-HWHTF
7	119-4729	1	Screw-Set, SQH	27	33113-012	1	Screw-HH
8	3217-7	1	Nut-Hex	28	33093-00	3	Washer-Flat
9	120-1795	1	Bar-Axle, Wheel	29	3256-23	1	Washer-Plain
12	98-3206	1	Decal				

● Not serviced separately

■ Obtain parts from [www.honda-engines.com](http://www.honda-engines.com)

# Handle Assembly

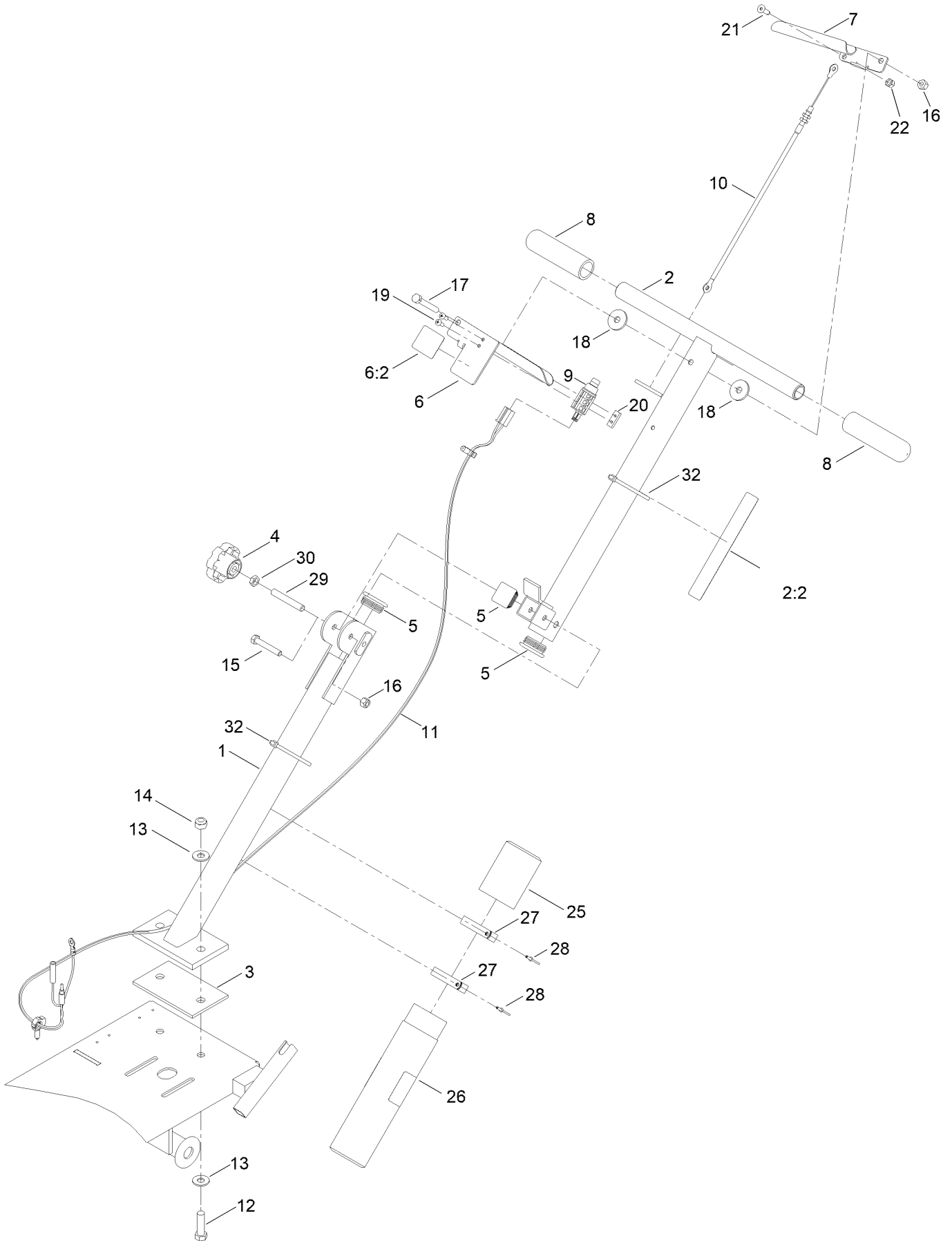

## Handle Assembly (continued)

<i>Ref.</i>	<i>Part Number</i>	<i>Qty.</i>	<i>Description</i>	<i>Ref.</i>	<i>Part Number</i>	<i>Qty.</i>	<i>Description</i>
1	120-1323-01	1	Handle-Lower	14	3296-48	2	Nut-Hex
2	121-4394	1	Handle ASM	15	322-10	1	Screw-HH
2:2	119-4691	1	Decal-Caution	16	3296-29	2	Nut-Lock, NI
3	120-1324	1	Gasket-Handle	17	322-11	1	Screw-HH
4	109-1092	1	Knob	18	107675	2	Washer
5	120-1302	3	Plug-Tube	19	1-803071	2	Screw
6	132-4121	1	Plunger Handle ASM	20	1-633181	1	Plate-Tapped
6:2	119-4722	1	Decal-Engage	21	116-0606	1	Screw-Torx
7	120-1359-05	1	Throttle Handle ASM [blk-Txt]	22	3296-42	1	Nut-Lock, NI
8	120-1333	2	Grip-Handle	25	104-7048	1	Cap-Housing
9	120-1292	1	Switch-Plunger, NC (W/Cover)	26	104-7050	1	Tube-Manual
10	120-1375	1	Cable-Throttle	27	2412-120	2	Clamp-R
11	120-1369	1	Harness-Wire	28	3269-17	2	Rivet-Pop
12	324-6	2	Screw-HH	29	120-0909	1	Screw-HSH
13	3256-4	4	Washer-Flat	30	3218-3	1	Nut-Jam
				32	3290-379	2	Tie-Cable

# 3-Tooth Grinder Wheel Assembly

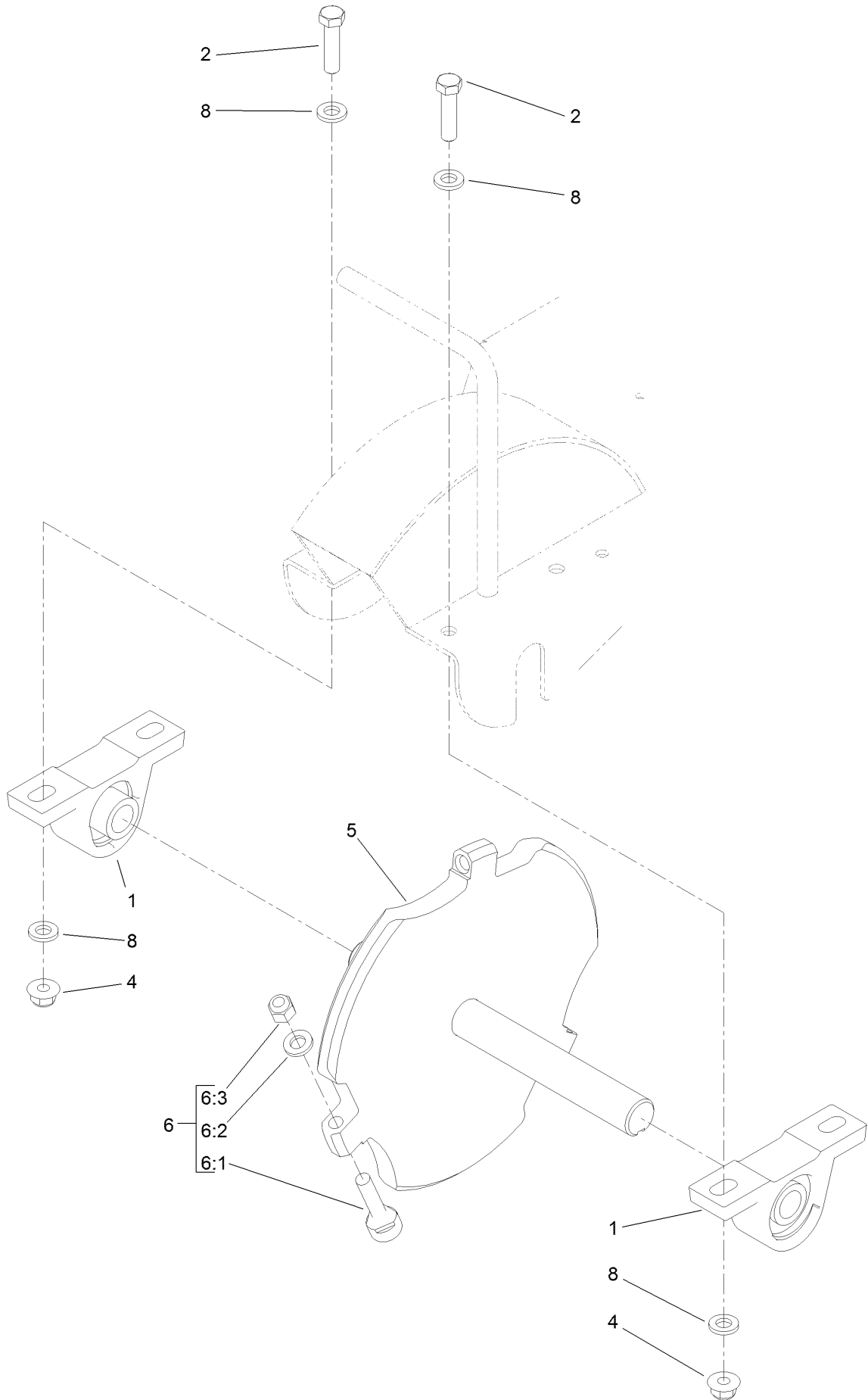

## 3-Tooth Grinder Wheel Assembly (continued)

<i>Ref.</i>	<i>Part Number</i>	<i>Qty.</i>	<i>Description</i>	<i>Ref.</i>	<i>Part Number</i>	<i>Qty.</i>	<i>Description</i>
1	120-1373	2	Bearing	6	132-4008	1	Grinder Tooth Kit (6-Pack)
2	3211-41	4	Screw-HH	6:1	130-2224	1	Tooth-Grinder
4	127-6852	4	Nut-Flange, Lock	6:2	107-1413	1	Washer-Hardened
5	137-7685	1	Wheel-Grinder	6:3	112-0236	1	Nut-Lock
6	132-4006	3	Grinder Tooth Kit (Single)	8	100-4852	8	Washer-Hardened
6	132-4007	1	Grinder Tooth Kit (3-Pack)				

# Brake and Wheel Assembly

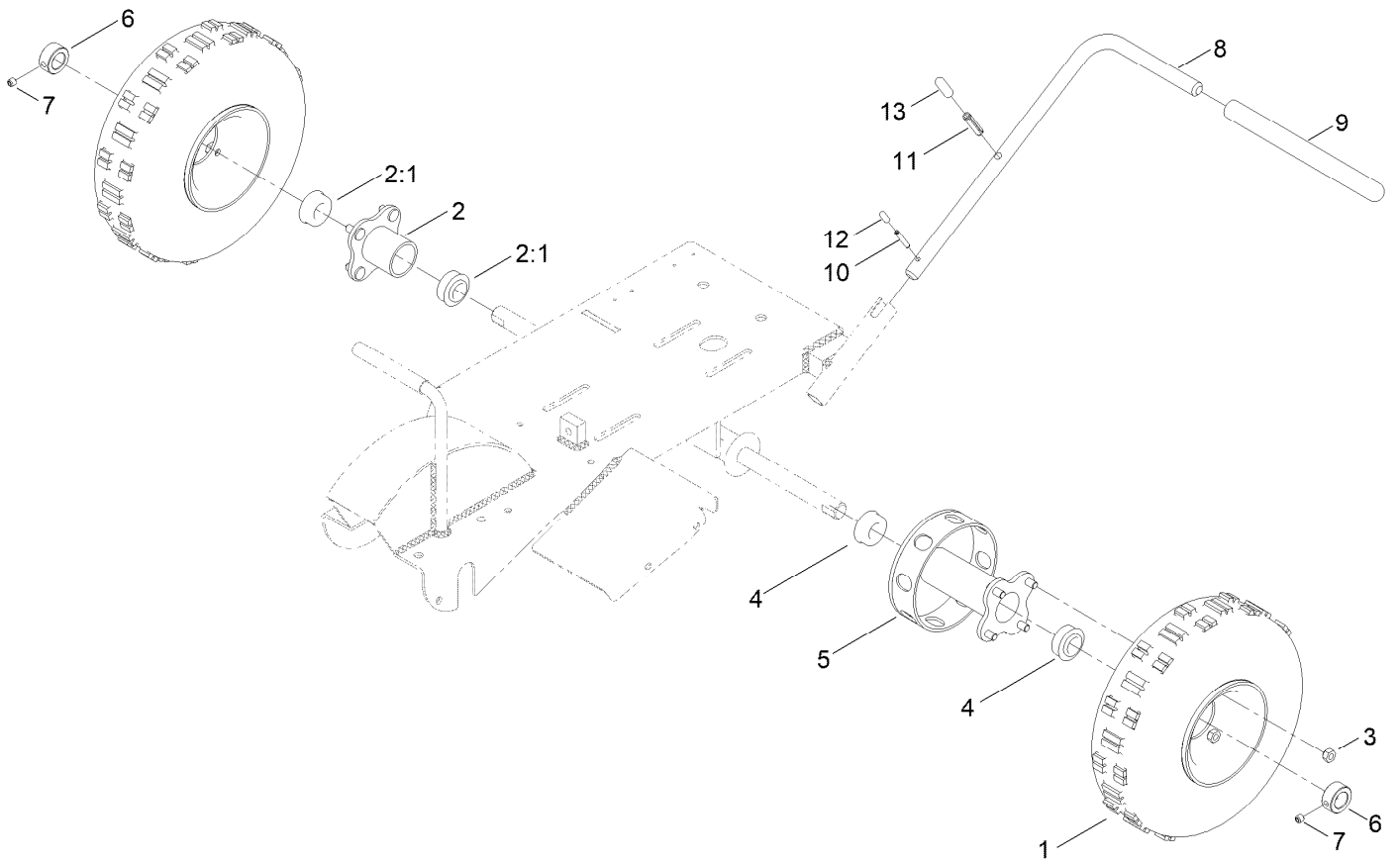

## Brake and Wheel Assembly (continued)

<i>Ref.</i>	<i>Part Number</i>	<i>Qty.</i>	<i>Description</i>	<i>Ref.</i>	<i>Part Number</i>	<i>Qty.</i>	<i>Description</i>
1	120-1288	2	Wheel And Tire ASM	7	3246-2	2	Screw-Set, HSH
2	120-1295	1	Hub	8	120-1309-01	1	Handle-Brake
2:1	120-1296	2	Bearing-Wheel	9	119-0222	1	Grip
3	120-1304	8	Nut-Wheel	10	32121-6	1	Pin-Roll, Slotted
4	120-1296	2	Bearing-Wheel	11	32121-25	1	Pin-Roll
5	120-1325-05	1	Brake Hub & Ring ASM [blk-Txt]	12	119-4741	1	Cap-Lower
6	120-1294	2	Collar-Set	13	119-4742	1	Cap-Upper

# Flap Assembly

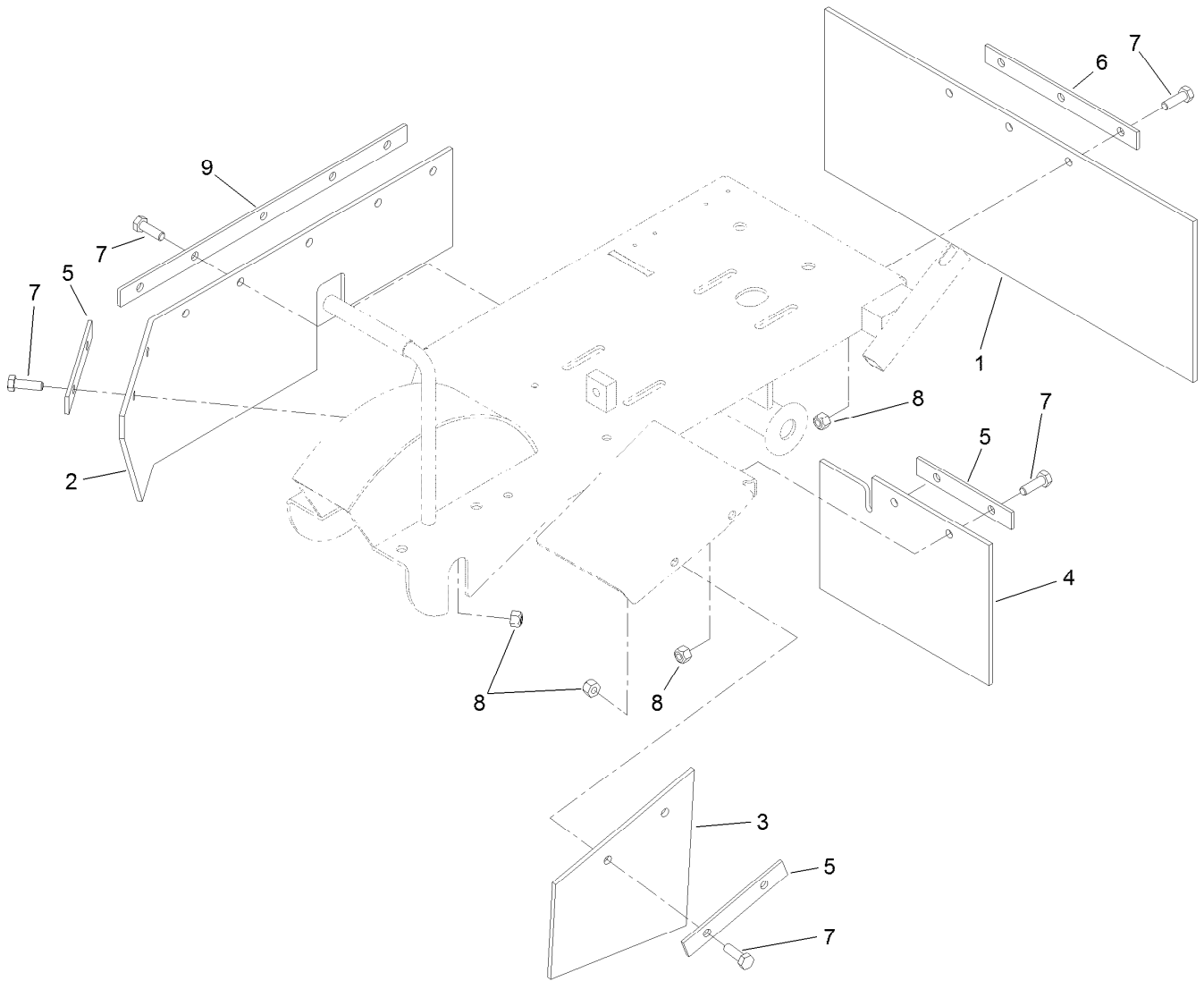

## Flap Assembly (continued)

<i>Ref.</i>	<i>Part Number</i>	<i>Qty.</i>	<i>Description</i>	<i>Ref.</i>	<i>Part Number</i>	<i>Qty.</i>	<i>Description</i>
1	120-5355	1	Flap-Rear	6	120-1246-01	1	Bracket-Support, Flap
2	120-5352	1	Flap-Right	7	322-5	14	Screw-HH
3	120-1313	1	Flap-Wing	8	3296-29	14	Nut-Lock, NI
4	120-5353	1	Flap-Wing, Rear	9	120-5354-01	1	Plate-Mounting, Flap
5	120-1315-01	3	Plate-Mounting, Flap				



## Drive Belt Assembly (continued)

<i>Ref.</i>	<i>Part Number</i>	<i>Qty.</i>	<i>Description</i>	<i>Ref.</i>	<i>Part Number</i>	<i>Qty.</i>	<i>Description</i>
1	137-7661	1	Clutch-Centrifugal	14	3234-47	2	Screw-HHF
2	115-7292	1	Washer-Hardened	15	3296-29	3	Nut-Lock, NI
3	98-3499	1	Washer-Flat	16	138-3128	1	Belt Guard ASM
4	3210-6	1	Screw-HH	16:2	119-4692	1	Decal-Caution
5	92-2649	1	Key-Square	16:3	119-4723	1	Decal
6	137-7662	1	Pulley-Front	16:4	120-1815	1	Decal
6:1	3246-3	1	Screw-HSH	16:5	137-4870	1	Decal-Service
7	137-7683	1	Belt-V, Banded	21	3-8664	2	Washer-Thrust
8	323-6	2	Screw-HH	24	137-3061	1	Bolt-CARR
11	3256-38	2	Washer-Flat	25	3256-67	1	Washer
12	137-7689	1	Plate-Guard, Inner	26	329-23	1	Screw-HH
12:2	117-4979	1	Decal-Warning				

# Attachments and Accessories

## For 22600 — SGR-6 Stump Grinder

<b>Product Name</b>	<b>Model/Part</b>
Wheel Tooth Kit.....	132-4006
3-Pack Wheel Tooth Kit.....	132-4007
6-Pack Wheel Tooth Kit.....	132-4008
New Red Paint - Gallon .....	361-11
Oil-30/10W-30 Synthetic (Quart).....	138-6053
10W30 4-Cycle Engine Oil (32oz Bottle).....	38280
Semi-Gloss Black Spray Paint .....	361-9

**Notes:**

**Notes:**

**Notes:**



**Count on it.**