



# Rear Roller Brush Kit

Reelmaster® 3555, 3575, and 5010 Series Cutting Unit with 5in or 7in Reel

Model No. 03406

Model No. 03408

## Installation Instructions

This product complies with all relevant European directives. For details, please see the Declaration of Incorporation (DOI) at the back of this publication.

The Rear Roller Brush Kit is mounted to the reel mowers on a ride-on machine and is intended to be used by professional, hired operators in commercial applications. It is primarily designed to keep the rear roller of the cutting unit free of grass and debris, which leads to a better after-cut appearance on well-maintained lawns in parks, sports fields, and on commercial grounds.

**Important:** Use the Rear Roller Brush Kit only when cutting in the height-of-cut range of 6 to 25 mm (1/4 to 1 inch). Use the high height-of-cut brush when cutting above 25 mm (1 inch). Refer to the procedure for Installing the High Height-of-Cut Brush (Optional).

**Note:** 5-inch cutting units driven by electric reel motors need the additional End-Weight Kit (Model 03413).

## Introduction

**Important:** Before installing this kit, ensure that you have a compatible cutting unit:

**03406** is designed for use on Reelmaster 3555, 5410, or 5010-H DPA 22 inch Cutting Units with a 5 inch reel.

**03408** is designed for use on Reelmaster 3575, 5510, 5610, or 5010-H DPA 22 inch Cutting Units with a 7 inch reel.

Refer to the following table for further detail:

Rear Roller Brush Kit	Compatible Cutting Units	Incompatible Cutting Units
03406 5 inch reel	All aluminum side plate cutting units, Model Numbers: 03621/23/24, 03634/5, and 03487/8/9	Painted red side plate DPA cutting units, Model Numbers: 03661, 03694/5
03408 7 inch reel	All aluminum side plate cutting units, Model Numbers: 03636/7/8/9 and 03641/43	Painted red side plate DPA cutting units, Model Numbers: 03681/2, 03696/7/8/9, 03693, and 03863/4



# Installation

## Loose Parts

Use the chart below to verify that all parts have been shipped.

Description	Qty.	Use
No parts required	—	Gather items needed for installation.
No parts required	—	Determine the roller brush orientation.
Roller-brush housing	5	Install the roller brush.
Hex-socket bolt (3/8 x 1 inch)	10	
Roller-brush assembly	5	
Shoulder bolt (5/16 x 0.62 inch)	5	
Right belt cover/plate assembly	2	
Left belt cover/plate assembly	3	
Bolt (5/16 x 1/2 inch)	20	
Spacer	5	
Drive pulley	5	
Flange-head bolt (3/8 x 2 inches)	5	
Belt	5	
Shim washer (as required for belt alignment)	5	
Right driveshaft	2	
Left driveshaft	3	
O-ring	5	
90° grease fitting	5	
High height-of-cut brush (optional)	—	Install the high height-of-cut brush—for HOC greater than 2.5 cm (1 inch).
End-Weight Kit (Model 03413) for the Reelmaster 5010-H with 5-inch cutting unit	—	Install the End-Weight Kit for the Reelmaster 5010-H with 5-inch cutting units.
Shoulder bolt (3/8 x 0.58 inch) (optional; sold separately)	—	Install the shoulder bolt for the Reelmaster 5010-H.

**Note:** Determine the left and right sides of the cutting unit from behind the cutting unit.

## Items Required for Installation

Acquire the following tools before proceeding with the installation:

- 1/2 inch deep-well socket
- 9/16 inch deep-well socket
- 1/2 inch ratchet wrench (Qty. 2)
- 5 inch reel-spline tool (Part No. TOR4074)\*
- 7 inch reel-spline tool (Part No. TOR4070)\*
- 1/8 inch t-hex wrench
- 5/16 inch t-hex wrench
- 3/8 inch wrench
- 5/16 inch wrench

- 1/2 inch wrench
- Torque wrench—2 to 3 N·m (20 to 25 in-lb)
- Torque wrench—20 to 25 N·m (15 to 19 ft-lb)
- Torque wrench—36 to 45 N·m (27 to 33 ft-lb)
- Torque wrench—47 to 54 N·m (35 to 40 ft-lb)
- Torque wrench—115 to 128 N·m (85 to 95 ft-lb)
- Long-handled pry bar (3/8 x 12 inches)

\*Order from K-Line Industries via their [website](#), email your order to [cservice@klineind.com](mailto:cservice@klineind.com), or call K-Line Customer Service at 1-800-824-5546.

# Determining the Roller Brush Orientation

All cutting units are shipped with the counterweight mounted to the left end of the cutting unit. Refer to [Figure 1](#) to determine the position of the roller brush and reel motors.

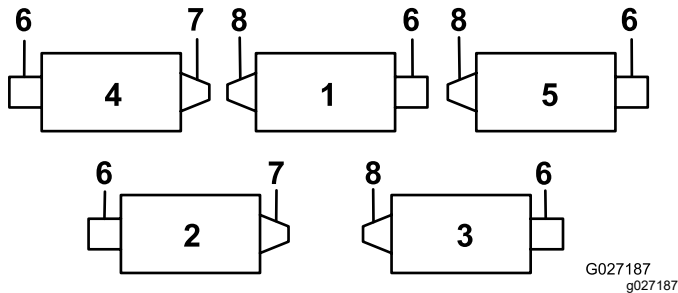

**Figure 1**

- |                   |                                      |
|-------------------|--------------------------------------|
| 1. Cutting unit 1 | 5. Cutting unit 5                    |
| 2. Cutting unit 2 | 6. Reel motor                        |
| 3. Cutting unit 3 | 7. Right roller-brush drive assembly |
| 4. Cutting unit 4 | 8. Left roller-brush drive assembly  |

**Note:** These instructions and illustrations show the installation of the kit on cutting units with the end weights mounted on the left end of the cutting unit.

## Installing the Roller Brush

### Installing the Driveshaft

Refer to the Maintenance Safety section in the *Operator's Manual* for your machine before installing this kit.

1. Park the machine on a level surface and set the parking brake.
2. Ensure that the cutting units are disengaged.
3. Shut the engine off and remove the key.
4. Remove all the cutting units from the machine.

**Important:** Check the cutting unit for the desired height of cut and attitude. Make adjustments per the *Operator's Manual*, if required, before installing the kit.

5. Restrain the reel for removal; refer to [Restraining the Reel for Removing Threaded Inserts](#) (page 13).
6. Remove the cutting-unit threaded insert for the rear-roller-brush drive ([Figure 1](#)) and discard it ([Figure 2](#)).

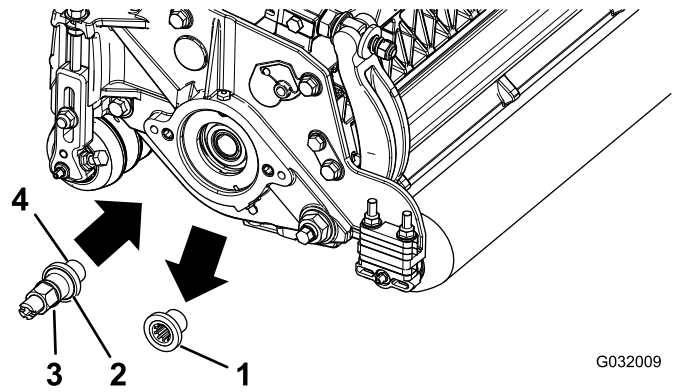

**Figure 2**

- |  |  |
|--|--|
| 1. Threaded insert (left-handed insert shown)                        | 3. Driveshaft                          |
| 2. The left-hand insert has a groove on the face of the insert here. | 4. Apply thread-locking compound here. |

**Note:** Left-handed inserts are on cutting units 1, 3, and 5 ([Figure 1](#)).

7. Restrain the reel for installation; refer to [Restraining the Reel for Installing Threaded Inserts](#) (page 14).
8. Apply thread-locking compound to the driveshaft threads ([Figure 2](#)) and install the driveshaft, torquing it to 115 to 128 N·m (85 to 95 ft-lb).

# Mounting the Roller-Brush Housing

1. Install the O-ring on the roller-brush housing as shown in [Figure 3](#).

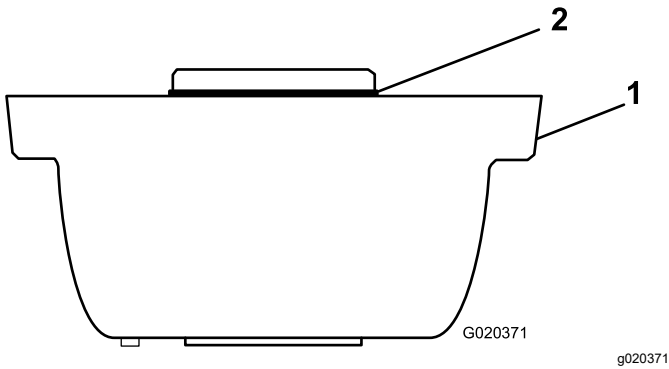

**Figure 3**

1. Roller-brush housing
2. O-ring

2. For Model 03408 only: Mount the roller-brush housing to the reel-bearing housing with 2 hex-socket bolts (3/8 x 1 inch); refer to [Figure 4](#).

**Note:** Position the roller-brush housing so that the threaded hole is toward the front of the cutting unit.

**Note:** Ensure that the O-ring is properly positioned in the roller-brush housing.

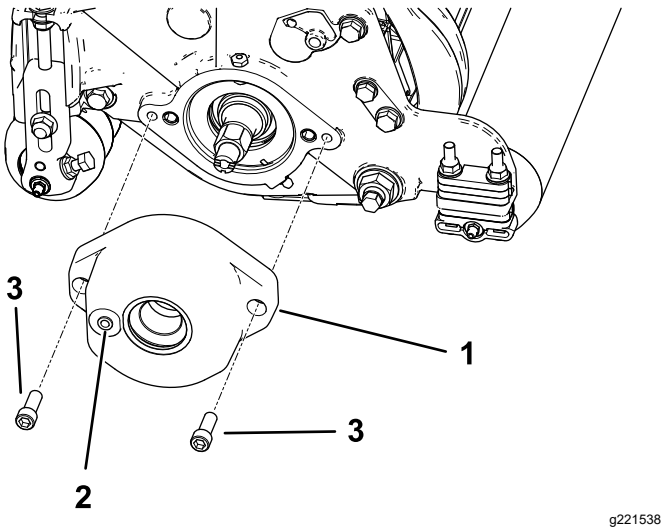
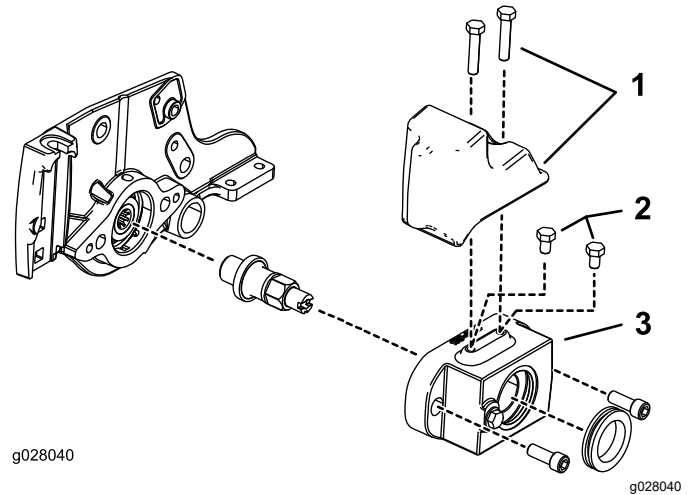

**Figure 4**

1. Roller-brush housing
2. Threaded hole
3. Hex-socket bolt

3. For Model 03406 Kit with RM5010 tractors with the following:

- Hydraulic 5-inch reel motors: Install 2 bolts (5/16-18 x 1/2 inch) on top of the roller-brush housing ([Figure 5](#)).
- Electric 5-inch reel motors: Install the End-Weight Kit on top of the roller-brush housing with 2 bolts (5/16-18 x 1-1/2 inches); refer to [Figure 5](#).

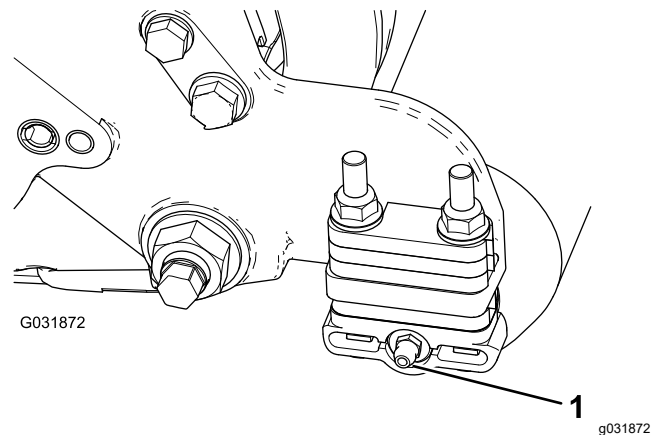

**Figure 5**

1. End-Weight Kit (Model 03413, electric reel motor)
2. Bolts (5/16-18 x 1/2 inch), hydraulic reel motor
3. Roller-brush housing

# Installing the Roller Brush Assembly

1. Remove the grease fitting for the roller from the side of the cutting unit that has the roller-brush housing ([Figure 7](#)).



**Figure 6**

1. Grease fitting
2. Install the 90° grease fitting so that it faces backward ([Figure 6](#)).

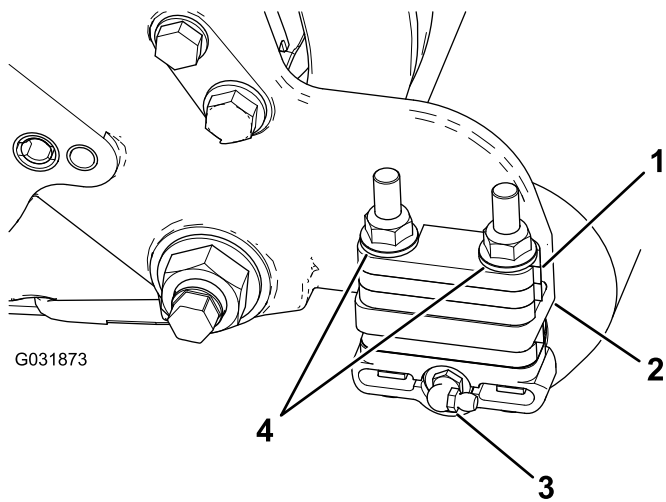

**Figure 7**

- |                               |                             |
|-------------------------------|-----------------------------|
| 1. 6 mm (1/4 inch) spacer     | 3. 90° grease fitting       |
| 2. Side-plate mounting flange | 4. Flange locknuts (remove) |

- Remove the 2 flange locknuts securing each roller bracket to the side plates (Figure 7).

**Note:** Do not remove the bolts. Also, remove any 6 mm (1/4 inch) spacers positioned on the top side of the side-plate mounting flange.

- Position the left or right roller-brush assembly mounting brackets onto the roller-bracket bolts (Figure 8).

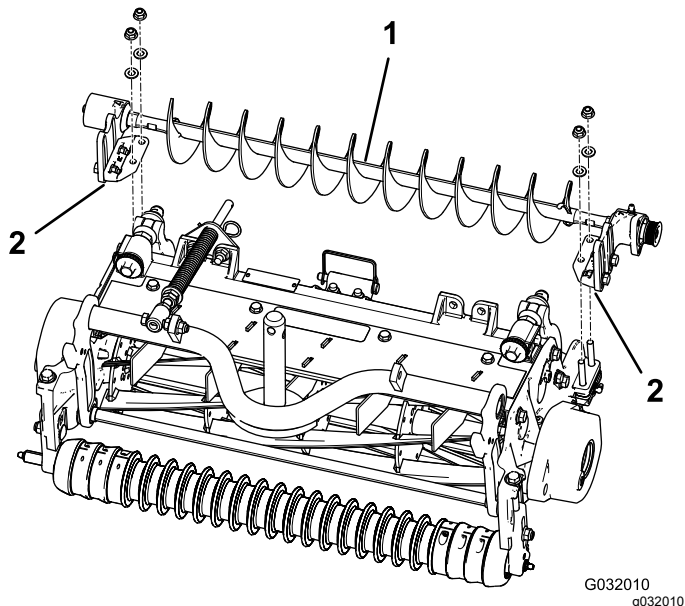

**Figure 8**

- |                               |                                  |
|-------------------------------|----------------------------------|
| 1. Left roller-brush assembly | 2. Roller-brush mounting bracket |
|-------------------------------|----------------------------------|

**Important:** Mount the roller-brush assembly mounting brackets directly to the top surface of the cutting-unit side-plate mounting

flange. Do not put spacers between the roller-brush mounting brackets and the side-plate mounting flanges. Save the additional 6 mm (1/4 inch) spacers for potential later use.

- Secure the brush-assembly mounting brackets to the cutting-unit side plates with the nuts previously removed.

## Installing the Roller Brush Plate

- Slide each excluder seal outward until the lip seals are in light contact with each bearing housing (Figure 9).

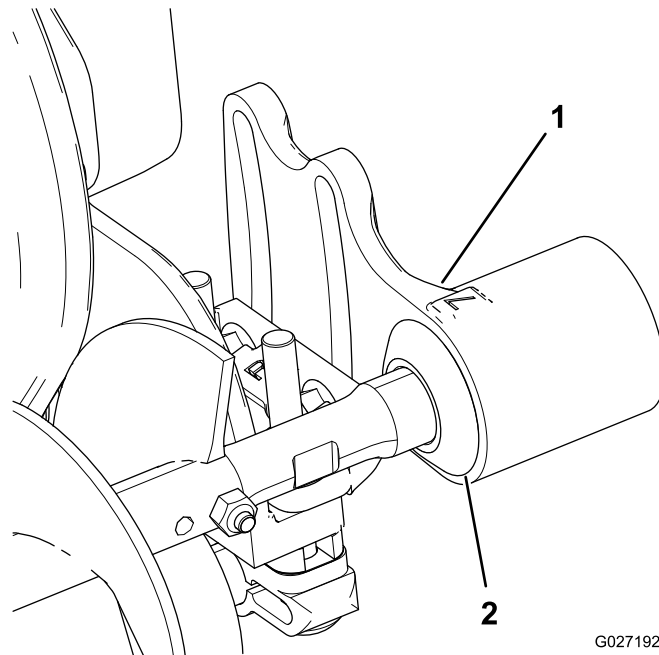

**Figure 9**

- |                    |                  |
|--------------------|------------------|
| 1. Bearing housing | 2. Excluder seal |
|--------------------|------------------|

- Apply a coating of grease to the inner diameter of the grommet in the roller-brush housing (Figure 10).

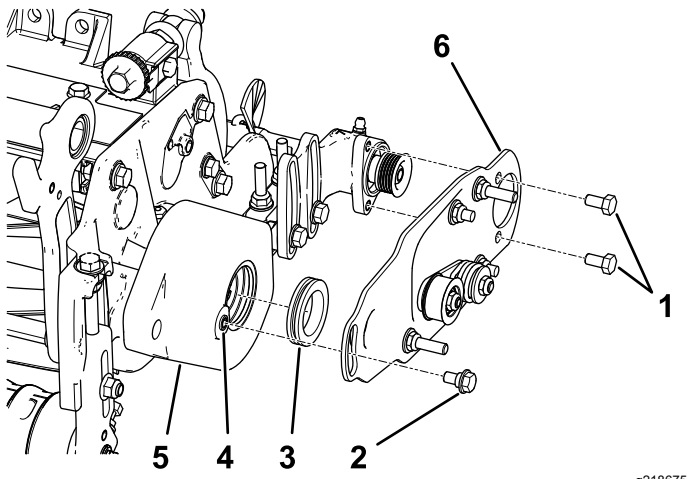

**Figure 10**

g218675

- |                                     |   |
|-------------------------------------|---|
| 1. Bolt                             | 4. Clean out any paint from the threads using a 5/16–18 tap before screwing in the shoulder bolt. |
| 2. Shoulder bolt (5/16 x 0.62 inch) | 5. Roller-brush housing   |
| 3. Grommet                          | 6. Roller-brush pivot plate assembly  |

3. Install the left or right roller-brush pivot plate (Figure 10).

**Note:** When you insert the protrusion on the pivot plate into the grommet in the roller-brush housing, ensure that the grommet stays properly seated in the housing. The roller-brush pivot plate is properly seated when there is no resistance from the rubber grommet and it pivots freely.

**Note:** Ensure that the idler-pulley assembly is installed on the bottom as shown in Figure 10.

4. Apply thread-locking compound to the 2 bolts (5/16 x 1/2 inch) and use them to mount the brush plate to the roller-brush bearing housing (Figure 10).

**Note:** Torque the bolts to 20 to 25 N·m (15 to 19 ft-lb).

5. Clean out any paint from the threads in the roller-brush housing, using a 5/16–18 tap, before screwing in the shoulder bolt (Figure 10).

**Important:** If the threads are not cleaned before the shoulder bolt is screwed in, the bolt could break.

6. Apply thread-locking compound to the shoulder bolt (Figure 10).
7. Secure the brush plate to the roller-brush housing with the shoulder bolt (Figure 10).

**Note:** Torque the bolt to 20 to 25 N·m (15 to 19 ft-lb).

**Note:** The shoulder bolt should not clamp the plate to the housing.

8. Check to ensure that the roller-brush plate is parallel to the cutting-unit side plate. If it is not parallel, proceed as follows:
  - A. Loosen the 2 flange locknuts securing the roller-brush mounting bracket to the cutting-unit side plate (Figure 11).
  - B. Rotate the roller-brush bearing housing until the brush plate is parallel to the cutting-unit side plate (Figure 11).
  - C. Tighten the 2 flange locknuts securing the roller-brush mounting bracket to the cutting-unit side plate (Figure 11).

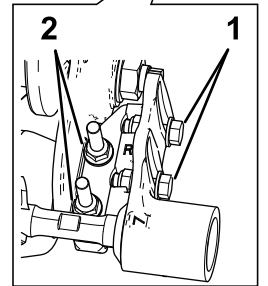
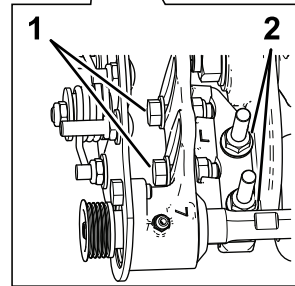
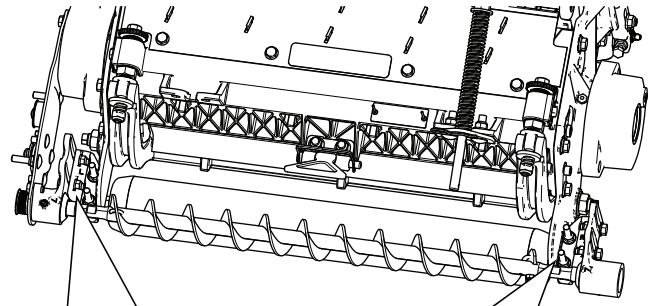

G027194  
g027194

**Figure 11**

1. Loosen these bolts for positioning the roller brush.
2. Loosen these nuts for making the roller-brush plate parallel.

## Positioning the Roller Brush

1. Loosen the 2 bolts securing each roller-brush bearing housing to the roller-brush mounting bracket (Figure 11).

**Note:** The bolts should be loose from the factory.

2. Position the roller brush so that it is just touching or resting on the rear roller (Figure 12).

**Important:** The roller-brush shaft must not contact the cutting-unit sideplate.

**Important:** Heavy brush contact on the roller will cause premature brush wear.

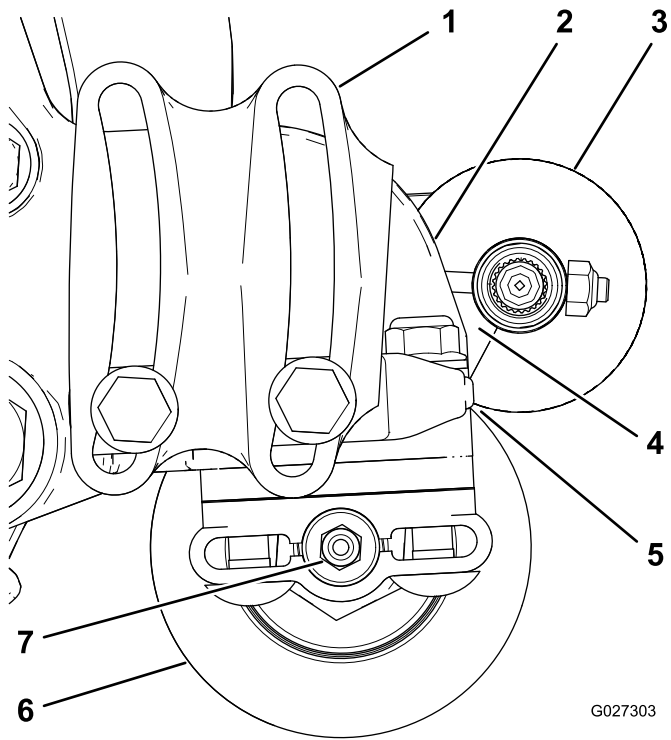

**Figure 12**

- |   |                   |
|---|-------------------|
| 1. Bearing housing (some parts not shown) | 5. Light contact  |
| 2. Sideplate                              | 6. Rear roller    |
| 3. Roller brush                           | 7. Grease fitting |
| 4. Ensure that there is clearance here.   |                   |

**Note:** The roller-brush shaft must be parallel to the rear roller.

**Important:** Position both roller-brush bearing housings so that they are parallel to the ground to ensure clearance for the rear-roller grease fitting.

- Tighten the 2 bolts securing each roller-brush bearing housing to the roller-brush mounting brackets.

## Installing the Drive Pulley

- Insert the spacer onto the shaft in the bearing housing (Figure 13).
- Insert the drive pulley into the spacer and onto the driveshaft (Figure 13).

**Note:** Ensure that the pulley tabs are positioned in the slot in the driveshaft.

- Secure the pulley and spacer to the driveshaft with a flange-head bolt (3/8 x 2 inches); refer to Figure 13.

**Note:** Torque the bolt to 47 to 54 N·m (35 to 40 ft-lb).

**Important:** If the bolt is *not* properly torqued, the bolt will come loose.

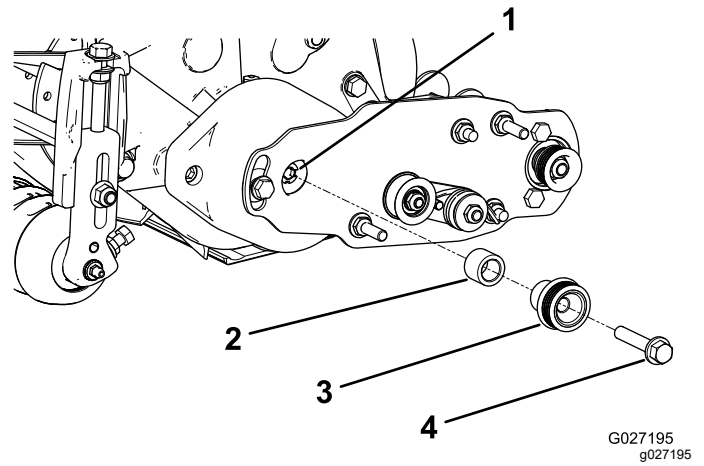
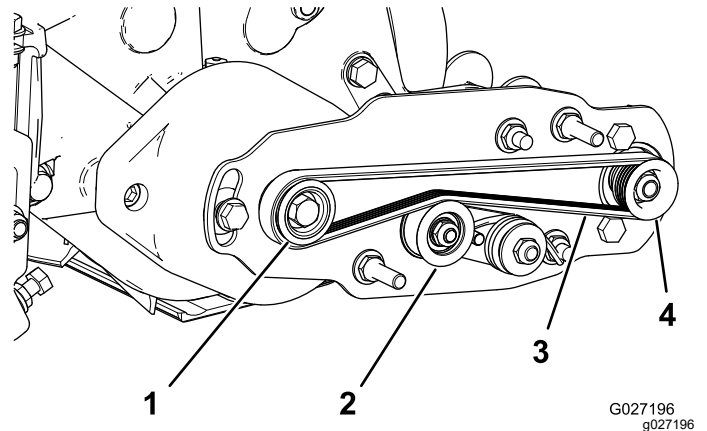

**Figure 13**

- |               |   |
|---------------|---|
| 1. Driveshaft | 3. Drive pulley   |
| 2. Spacer     | 4. Flange-head bolt—torque to 47 to 54 N·m (35 to 40 ft-lb) |

## Installing the Belt

- Install the belt onto the pulleys as follows:
  - Loop the belt around the **drive** pulley and then over the top of the idler pulley (Figure 14).



**Figure 14**

- |                          |                  |
|--------------------------|------------------|
| 1. Drive pulley          | 3. Belt          |
| 2. Idler-pulley assembly | 4. Driven pulley |

- Start the belt on the **driven** pulley (Figure 15).
- Use a deep-well socket (9/16 inch) to rotate the brush assembly and guide the belt onto the driven pulley (Figure 15).

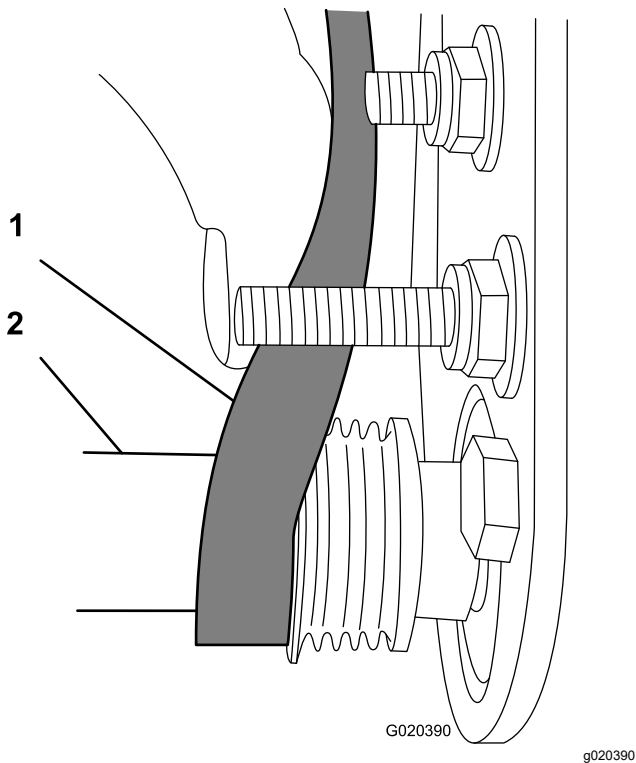

**Figure 15**

1. Belt
2. Deep-well socket (9/16 inch)

**Important:** Ensure that the ribs on the belt are properly seated in the grooves in each pulley and that the belt is in the center of the idler pulley.

2. Push down on the idler pulley to ensure that the idler-pulley assembly pivots freely.

## Completing the Installation

1. Check the alignment of the belt and pulleys as follows:
  - The belt must be properly tensioned (installed) prior to checking the alignment.
  - Lay a straightedge along the outer face of the **drive** pulley (Figure 16). **Do not** lay the straightedge across both the drive pulley and the driven pulley.
  - The outer faces of the drive pulley and the driven pulley should be in line within 0.76 mm (0.030 inch).
  - If the pulleys are not aligned, refer to [Checking the Pulley Alignment \(page 11\)](#).
  - If the pulleys are aligned, continue with the installation.
  - **Do not** use the idler pulley to check the alignment.

**Important:** The belt may fail prematurely if the pulleys are not properly aligned.

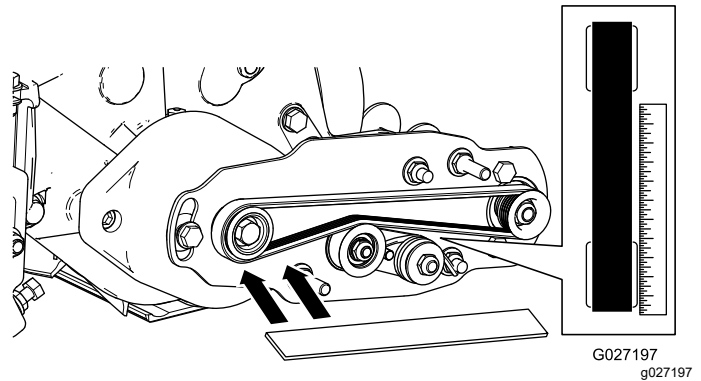

**Figure 16**

2. Slide the belt cover onto the mounting bolts and secure the cover with 2 flange nuts (Figure 17).

**Important:** Do not overtighten the nuts as damage to the cover may occur.

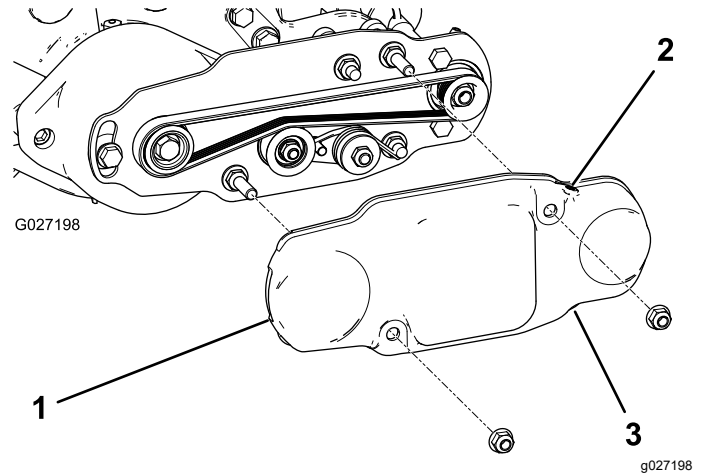

**Figure 17**

1. Belt cover
2. Setscrew installed
3. Setscrew removed

3. Lubricate the grease fittings on each of the roller-brush bearing housings with No. 2 lithium grease (Figure 18). Wipe off any excess grease, especially around the excluder seals.

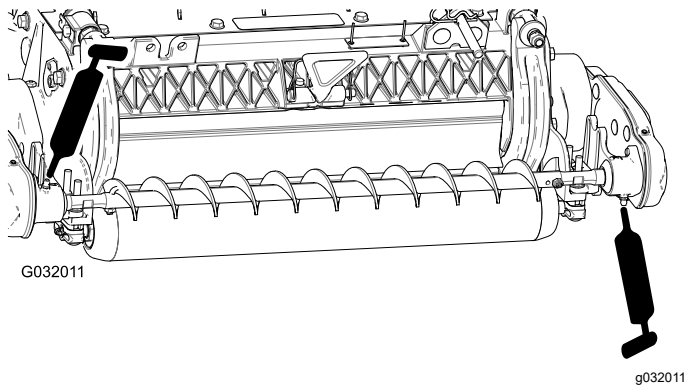

Figure 18

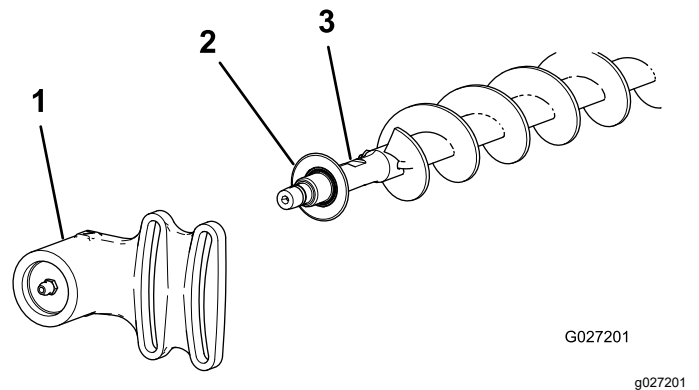

Figure 20

1. Non-drive bearing housing
2. Excluder seal
3. Brush shaft

## Installing the High Height-of-Cut Brush

### (Optional)

Install the high height-of-cut brush (sold separately) when the height of cut is 2.5 cm (1 inch) or more (5 or more spacers installed below the side plate pad).

1. If a roller brush is installed on the cutting unit, remove the 2 bolts, washers, and nuts securing the non-drive bearing housing to the bearing-housing mounting bracket (Figure 19 and Figure 20).

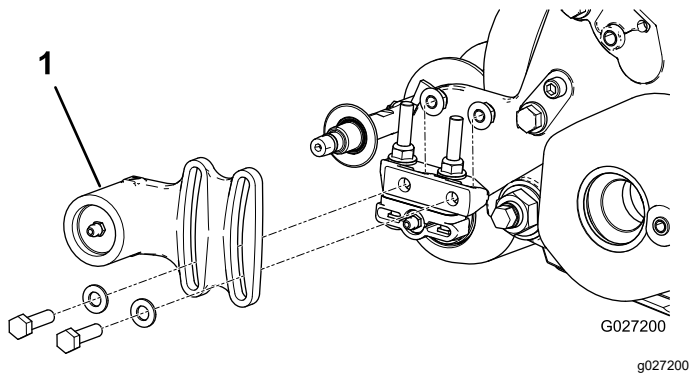

Figure 19

1. Non-drive bearing housing

2. Slide the non-drive bearing housing and the excluder seal off the brush shaft (Figure 20).

3. Remove the 2 J-bolts and the nuts (Figure 21).
  4. Slide the existing brush off the brush shaft (Figure 21).
  5. Loosen the 2 bolts, washers, and nuts securing the drive-bearing housing to the bearing-housing mounting bracket (Figure 21).
  6. Slide the high height-of-cut brush onto the brush shaft (Figure 21).
  7. Clamp the brush onto the shaft with the 2 J-bolts and nuts previously removed (Figure 21).
- Important:** Insert the threaded end of the J-bolts through the outer holes of the brush shaft while hooking the curved ends of the J-bolts into the inner holes.
8. Torque the J-bolt locknuts to 2 to 3 N·m (20 to 25 in·lb).

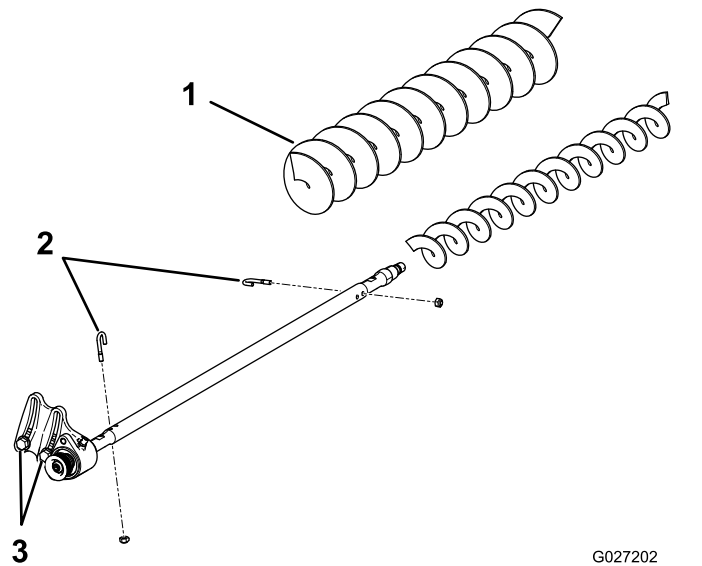
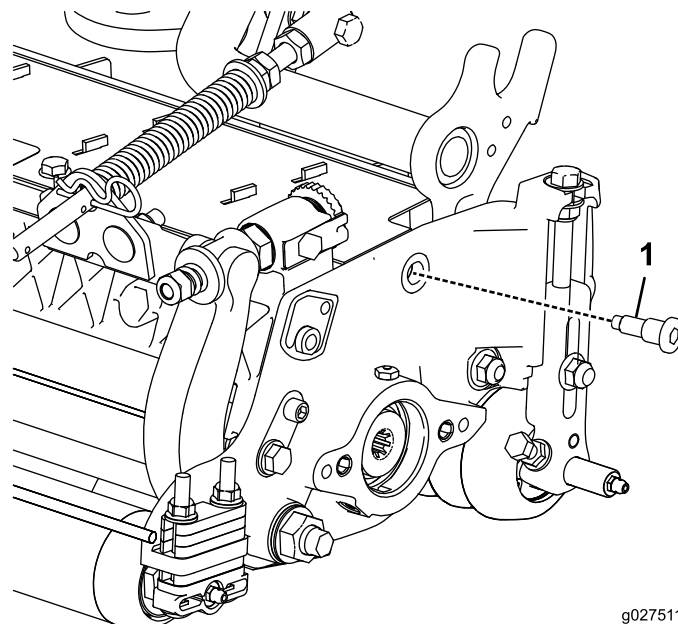

Figure 21

1. High height-of-cut brush
2. J-bolts
3. Loosen these bolts.

9. Install the excluder seal and the non-drive bearing housing onto the brush shaft ([Figure 20](#)).
10. Mount the non-drive bearing housing to the bearing-housing mounting bracket with the 2 bolts, washers, and nuts previously removed.
 

**Note:** Be careful not to knock the seal spring off.
11. Tighten the 2 bolts, washers, and nuts securing the drive-bearing housing to the bearing-housing mounting bracket.



g027511  
g027511

**Figure 22**

1. New shoulder bolt (3/8 x 0.58 inch)

## Installing the End-Weight Kit for the Reelmaster 5010-H with 5-inch Cutting Units

**Note:** The End-Weight Kit is only required for the Reelmaster 5010-H with 5-inch cutting units.

Refer to the *Installation Instructions* for the weight kit.

## Installing the Shoulder Bolt For pre-2025 Reelmaster 5010-H machines

**Note:** Contact your authorized Toro distributor for the new shoulder bolt.

1. Replace the existing shoulder bolt with a new shoulder bolt (3/8 x 0.58 inch) as shown in [Figure 22](#) before installing the reel motor.
2. Torque the shoulder bolt to 37 to 45 N·m (27 to 33 ft·lb).

**Note:** The new shoulder bolt prevents interference with the electric motor.

# Maintenance

- Ensure that the brush is parallel to the roller with 1.5 mm (0.060 inch) clearance to light contact.
- Grease the fittings every 50 hours and after every washing.
- When replacing a roller brush, torque the J-bolts to 2 to 3 N·m (20 to 25 in-lb).
- When replacing the brush-shaft-driven pulley, torque the nut to 36 to 45 N·m (27 to 33 ft-lb).
- When replacing the brush-drive pulley, apply 242 Loctite (blue) and torque the bolt to 47 to 54 N·m (35 to 40 ft-lb).

**Note:** The roller brush, the idler bearing, and the belt are considered consumable items.

## Checking the Pulley Alignment

1. The driven pulley (at the roller-brush shaft) can move in or out ([Figure 23](#)).

**Note:** Make note of which way the pulley needs to move.

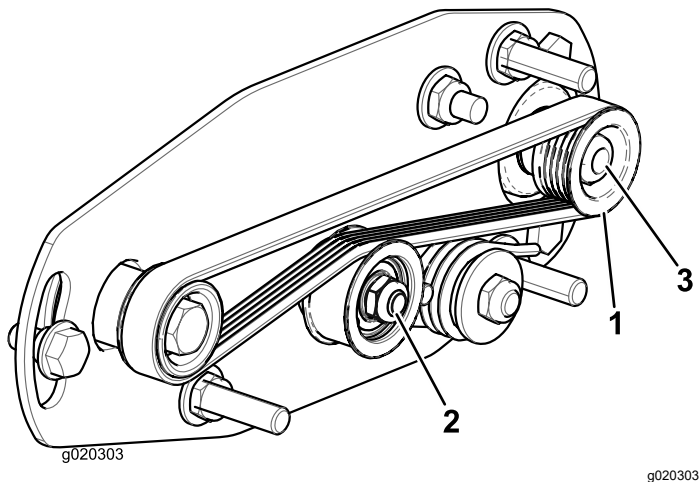

**Figure 23**

- |                          |                      |
|--------------------------|----------------------|
| 1. Driven pulley         | 3. Driven-pulley nut |
| 2. Idler pulley assembly |                      |

2. While rotating the reel, which rotates the drive pulley, pry the belt off the drive pulley ([Figure 23](#)

**Note:** Wear a padded glove or use a heavy rag to rotate the reel.

3. Remove the locknut securing the driven pulley to the brush shaft ([Figure 23](#) or [Figure 24](#)).

**Note:** Use a 1/2-inch wrench on the roller-brush shaft flats to keep it from rotating.

4. Remove the driven pulley from the shaft ([Figure 24](#)).

5. If the pulley needs to move out, add a 0.8 mm (0.032 inch) thick washer ([Figure 24](#)).

**Note:** If the pulley needs to move in, remove the existing 0.8 mm (0.032 inch) thick washer.

6. Install the pulley.

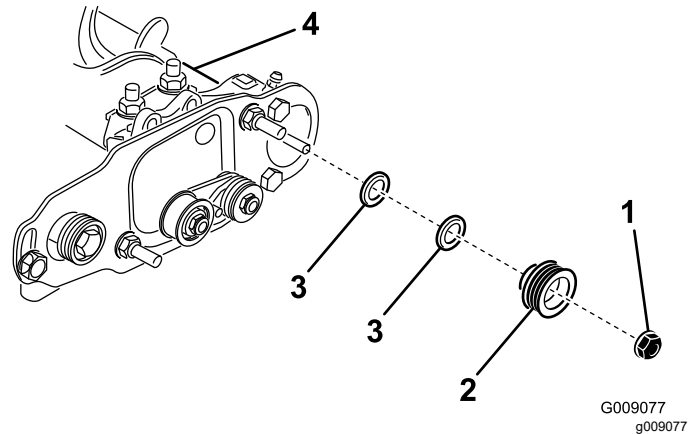

**Figure 24**

- |                  |                                     |
|------------------|-------------------------------------|
| 1. Locknut       | 3. Washer—0.8 mm (0.032 inch) thick |
| 2. Driven pulley | 4. Brush-shaft flats                |

7. While holding the brush-shaft flats, secure the driven pulley on the shaft with the 3/8-16 flange nut previously removed.

**Note:** Seat the locknut; then torque it to 36 to 45 N·m (27 to 33 ft-lb).

8. Install the belt onto the pulleys as follows:

- A. Loop the belt around the **drive** pulley and then over the top of the idler pulley ([Figure 25](#)).

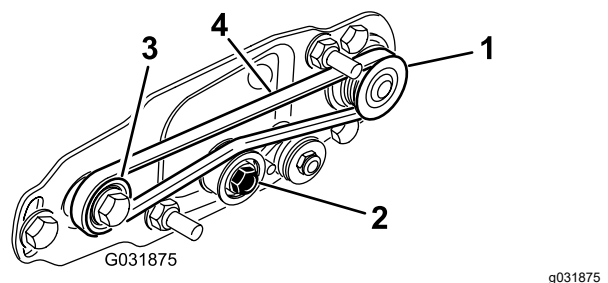
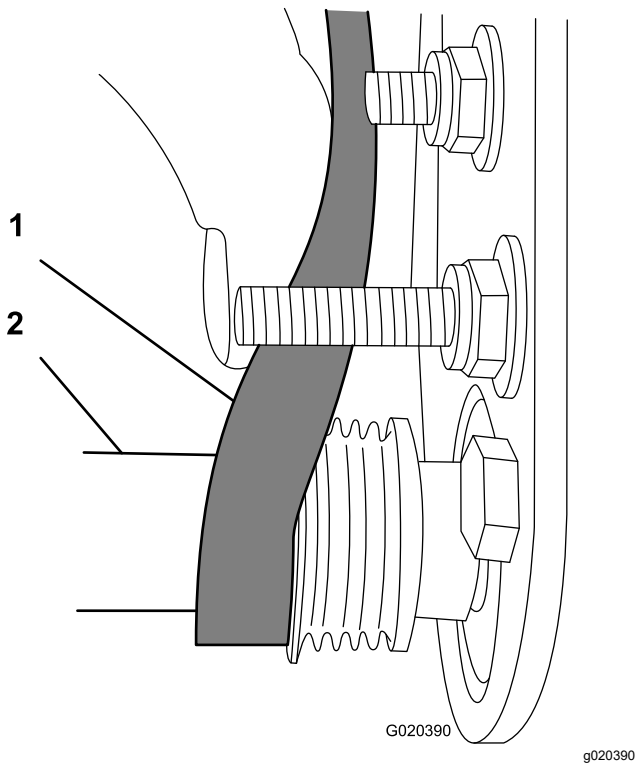

**Figure 25**

- |                          |                 |
|--------------------------|-----------------|
| 1. Driven pulley         | 3. Drive pulley |
| 2. Idler-pulley assembly | 4. Belt         |

- B. Start the belt on the **driven** pulley ([Figure 25](#)).

- C. Use a deep-well socket (9/16 inch) to rotate the brush assembly and guide the belt onto the driven pulley ([Figure 26](#)).



**Figure 26**

1. Belt
2. Deep-well socket (9/16 inch)

---

***Important:*** Ensure that the ribs on the belt are properly seated in the grooves in each pulley and that the belt is in the center of the idler pulley.

9. Check the pulley alignment and adjust it if necessary.

# Restraining the Reel

## ⚠ WARNING

The cutting reel blades are sharp and capable of amputating hands and feet.

- Keep your hands and feet outside of the reel.
- Ensure that the reel is restrained before servicing it.

## Restraining the Reel for Removing Threaded Inserts

1. Loosen the shield-bolt on the left side of the cutting unit and raise the rear shield (Figure 27).
2. Insert a long-handled pry bar (recommended 3/8 inch x 12 inches with screwdriver handle) through the back of the cutting reel, closest to the side of the cutting unit that you will be torquing (Figure 27).
3. Place the pry bar against the weld side of the reel support plate (Figure 27).

**Note:** Insert the pry bar between the top of the reel shaft and the backs of 2 reel blades so that the reel will not move.

**Important:** Do not contact the cutting edge of any blades with the pry bar; this may damage the cutting edge and/or cause a high blade.

**Important:** The insert on the left side of the cutting unit has left-hand threads. The insert on the right side of the cutting unit has right-hand threads.

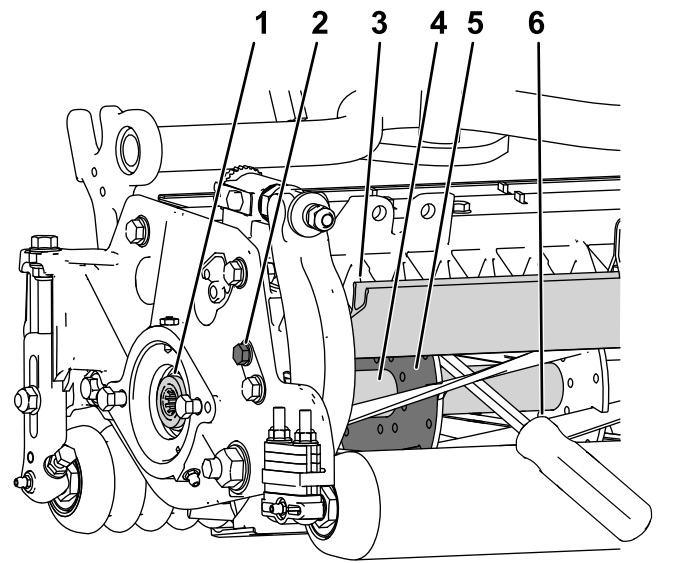

g280383

Figure 27

- |                                |  |
|--------------------------------|--|
| 1. Threaded insert for removal | 4. Reel shaft  |
| 2. Loosen the shield bolt.     | 5. Reel support plate  |
| 3. Rear shield                 | 6. Pry bar inserted along the weld side of the reel support plate. |
- 
4. Rest the handle of the pry bar against the rear roller.
  5. Complete the removal of the threaded insert while ensuring that the pry bar stays in place, then remove the pry bar.
  6. Lower the rear shield and tighten the shield-bolt.

## Restraining the Reel for Installing Threaded Inserts

1. Insert a long-handled pry bar (recommended 3/8 inch x 12 inches with screwdriver handle) through the front of the cutting reel, closest to the side of the cutting unit that you will be torquing (Figure 28).
2. Place the pry bar against the weld side of the internal cutting reel reinforcement (Figure 28).

**Note:** The pry bar should contact a blade at the front, the reel shaft, and a blade at the back of the reel, locking it in place.

**Important:** Do not contact the cutting edge of any blades with the pry bar; this may damage the cutting edge and/or cause a high blade.

**Important:** The insert on the left side of the cutting unit has left-hand threads. The insert on the right side of the cutting unit has right-hand threads.

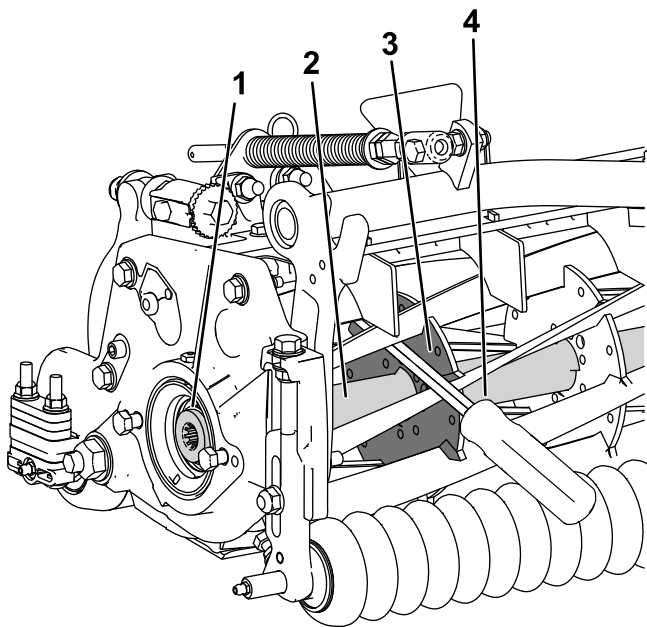

g280384

Figure 28

- |                                     |                               |
|-------------------------------------|-------------------------------|
| 1. Threaded insert for installation | 3. Weld side of support plate |
| 2. Reel shaft                       | 4. Pry bar                    |

3. Rest the handle of the pry bar against the roller
4. Per the insert's installation instructions and torque requirements, complete the installation of the threaded insert while ensuring that the pry bar stays in place, then remove the pry bar.

# Declaration of Incorporation

The Toro Company, 8111 Lyndale Ave. South, Bloomington, MN, USA declares that the following unit(s) conform(s) to the directives listed, when installed in accordance with the accompanying instructions onto certain Toro models as indicated on the relevant Declarations of Conformity.

Model No.	Serial No.	Product Description	Invoice Description	General Description	Directive
03406	—	Rear Roller Brush Kit, Reelmaster 5010-H Series Cutting Unit with 5in Reel	RRB ONLY KIT 5IN CU [RM 5010]	Roller Brush Kit	2006/42/EC
03408	—	Rear Roller Brush Kit, Reelmaster 5010-H Series Cutting Unit with 7in Reel	RRB ONLY KIT 7IN CU [RM 5010]	Roller Brush Kit	2006/42/EC

Relevant technical documentation has been compiled as required per Part B of Annex VII of 2006/42/EC.

We will undertake to transmit, in response to requests by national authorities, relevant information on this partly completed machinery. The method of transmission shall be electronic transmittal.

This machinery shall not be put into service until incorporated into approved Toro models as indicated on the associated Declaration of Conformity and in accordance with all instructions, whereby it can be declared in conformity with all relevant Directives.

Certified:



Tom Langworthy  
Engineering Director  
8111 Lyndale Ave. South  
Bloomington, MN 55420, USA  
October 21, 2022

Authorized Representative:

Marcel Dutrieux  
Manager European Product Integrity  
Toro Europe NV  
Nijverheidsstraat 5  
2260 Oevel  
Belgium



**Count on it.**