



# Multi Pro® 5800 and 5800-G Turf Sprayer

Model No. 41394—41900000 and Up

Model No. 41394GK—41900000 and Up

## Software Guide

# Overview of the InfoCenter Display

The InfoCenter display shows information about your machine such as the operating status, various diagnostics and other information about the machine. There are multiple screens on the display. You can switch between the screens, at any time, by pressing the back button and then using the up and down directional buttons.

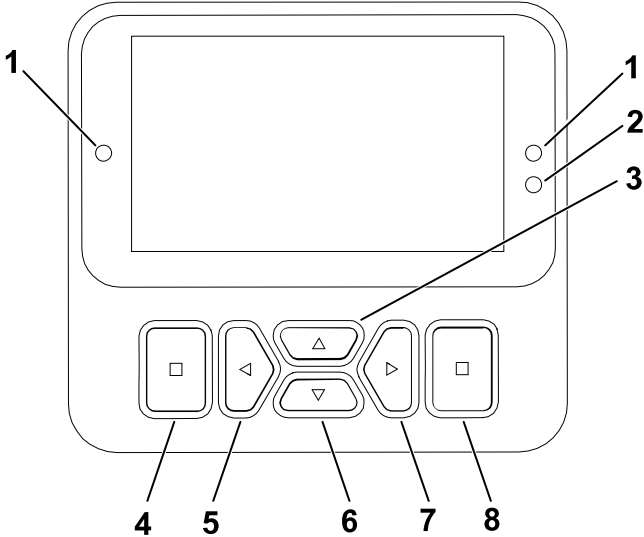















G471371s













- ① Indicator light
- ② Display brightness sensor
- ③ Navigation button—up
- ④ Back button
- ⑤ Navigation button—decrease/left
- ⑥ Navigation button—down
- ⑦ Navigation button—increase/right
- ⑧ Enter button

**Note:** The purpose of each button may change depending on what is required at the time. Each button is labeled with an icon displaying its current function.

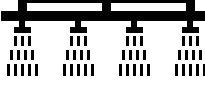

# Display Icons

	Menu
	Locked
	Scroll up/down
	Scroll left/right
	Previous screen
	Decrease value
	Increase value
	Accept
	Save
<b>PIN</b>	PIN passcode
	Exit (faults) menu
	Battery voltage
	The parking brake is on.
	Sit in the seat.
	Hour meter

	Tank is empty (less than 10% volume)
	Rinse tank indicator
	Agitation indicator
	Rinse and agitation indicator
	Low tank indicator. A tank icon will appear in the middle of these 2 icons.
<b>±1</b>	Increase the tank volume by 1 gallon
<b>±10</b>	Increase the tank volume by 10 gallons
<b>±25</b>	Increase the tank volume by 25 Liters
	Boom is off
	Boom is active
	Clear all areas
	Clear active area
	Areas sprayed
	All areas screen
	Navigate to a sprayer area
	

# Overview of the Menus

To access the InfoCenter display menu system, press the back button while at the main screen. This brings you to the main menu. Refer to the following tables for a synopsis of the options available from the menus.

🔒 Protected under Protected Menus—accessible only by entering PIN

## Main Menu

Menu Item	Description
Set Rates	Sets the preset and boost rates.
Settings	Customize and modify the display configuration variables.
Machine Settings	Configure machine variables.
Calibration 🔒	Assists in calibration of the flow meter and speed sensor.
Service	Contains information on the machine such as hours of use and machine faults.
Diagnostics	Displays the state of each machine switch, sensor, and control output. You can use this to troubleshoot certain issues as it quickly tells you which machine controls are on and which are off.
About	Lists the model number, serial number, and software version of your machine.

## Set Rates

Menu Item	Description
Active Rate	Displays the rate currently being used.
Rate 1	Sets a preset rate.
Rate 2	Sets a preset rate.
Boost	Sets a percentage to be added to the active rate.

## Settings

Menu Item	Description
Enter PIN	Allows a person (superintendent/mechanic) authorized by your company with the PIN code to access protected menus.
Protect Settings 🔒	Allows the ability to change the settings in the protected settings.
Reset Defaults 🔒	Resets the default values.
Backlight	Controls the brightness of the LCD display.

## Settings (continued)

Menu Item	Description
Language	Controls the language used on the display.
Units	Controls the units used on the display (Imperial, Turf, or Metric).

## Machine Settings

Menu Item	Description
Tank	Sets the tank volume, low tank alert, and preset agitation value.
Booms	Adjusts the boom widths.
Geolink	Satellite navigation option.
Reset	Resets the machine values.

## Calibration

Menu Item	Description
Flow Calibration	Calibrates the flow meter.
Speed Calibration	Calibrates the speed sensor.
Test Speed	Sets the test speed for calibration.
Manual Cal Entry	Manually enter the calibration.
Use Default Flow Calibration?	Resets the flow calibration to the default calculated average, not the actual volume.
Use Default Speed Calibration?	Resets the speed calibration to the default calculated average, not the actual speed.

## Service

Menu Item	Description
Hours	Lists the total number of hours that the machine, engine and PTO have been on, as well as the number of hours the machine has been transported and service due.
Flow Rate 	Displays the current flow rate.



## Diagnostics

Menu Item	Description
Pumps	Accesses the pump inputs, momentary rinse, and time rinse options.
Booms	Accesses the boom inputs and outputs.

## Diagnostics (continued)

Menu Item	Description
Engine Run	Accesses the engine run inputs and outputs.
Faults	Displays the most recent machine faults. Refer to the <i>Service Manual</i> or contact your authorized Toro distributor for more information.

## About

Menu Item	Description
Model	Lists the model number of the machine.
SN	Lists the serial number of the machine.
S/W Revision	Lists the software revision of the primary controller.
XDM-4400 	Lists the software revision of the InfoCenter.
CAN Statistics 	Lists the CAN Bus

## Protected Menu

There are operating configuration settings that are adjustable within **Settings** of the display. To lock these settings, use the **Protected Menu**.

**Note:** At the time of delivery, the initial password code is programmed by your distributor.

## Accessing Protected Menus

**Note:** The factory default PIN code for you machine is either 0000 or 1234.

If you changed the PIN code and forgot the code, contact your authorized Toro distributor for assistance.

1. From the **Main Menu**, scroll down to **Settings** and press the select button.

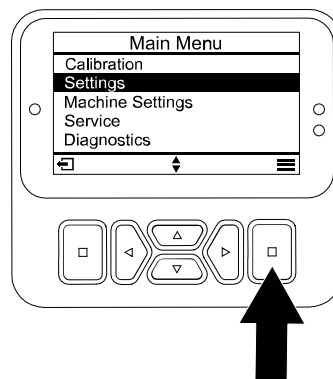

G510565

## Accessing Protected Menus (continued)

2. In **Settings**, scroll to **Enter PIN** and press the select button (A).
3. To enter the PIN code, press the up/down navigation buttons (B) until the correct first digit appears, then press the right navigation button (C) to move on to the next digit. Repeat this step until the last digit is entered.
4. Press the select button (D).

**Note:** If the display accepts the PIN code and the protected menu is unlocked, the word "PIN" displays in the upper right corner of the screen.

5. To lock the protected menu, rotate the key switch to the OFF position and then to the ON position.

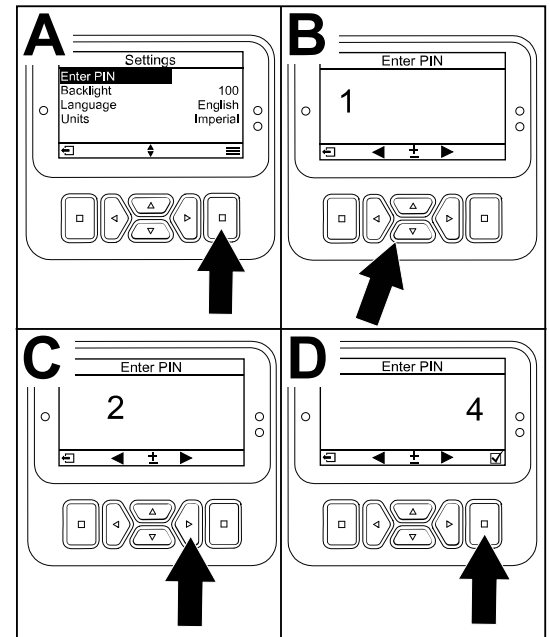

G510564

## Viewing and Changing the Protected Menu Settings

1. In **Settings**, scroll down to **Protect Settings**.
2. To view and change the settings without entering a PIN code, use the select button to change the **Protect Settings** to  (Off).
3. To view and change the settings with a PIN code, use the select button to change the **Protect Settings** to  (On), set the PIN code, and turn the key in the ignition switch to the OFF position and then to the ON position.

## Setting the Spray Tank Alert

1. Select **Machine Settings**.
2. Select **Tank**.
3. Select **Tank Limit**.
4. Use the directional buttons to enter the minimum quantity in the tank when the alert displays during sprayer operation.

## Setting the Boom Sizes

1. Select **Machine Settings**.
2. Select **Booms**.
3. Select the boom you would like to update.
4. Use the directional buttons to change the boom size in increments of 1 inch (2.5 cm).

# Resetting the Default Settings

1. Select **Machine Settings**.
2. Select **Reset Defaults**.

# Entering the Spray Tank Volume

**Note:** Changing the volume will reset the tank alert.

1. Select **Machine Settings**.
2. Select **Tank**.
3. Select **Volume**.
4. Press the button to increase or decrease the tank volume.
  - A. Press the up/down directional buttons **Ⓜ** to jump to  $\pm 10$  (for US units) or  $\pm 25$  (for metric units).
  - B. Press the left/right directional buttons **Ⓛ** to change the volume by 1 increment.

# Setting the Preset Agitation Value

## Application Rate Mode Only

**Note:** The preset agitation setting is used to set the sprayer pump speed when the sprayer is operated in the Application Rate Mode with all sprayer section shut off. The preset agitation setting controls the percentage of sprayer pump speed. The default preset agitation setting is 40%.

1. Identify the target sprayer pressure that you are planning to spray.  
For example: 2.76 bar (40 psi). Record the pressure displayed on the dash mounted sprayer-pressure gauge below.

Sprayer  
pressure:

---

2. Calculate the initial agitation preset pressure using the formula below.  
Sprayer operation pressure x 1.5 to 2.0 = initial agitation preset pressure.  
Example: target sprayer pressure 2.76 bar (40 psi) x 1.5 = initial agitation preset pressure 4.1 (60 psi)  
Example: target sprayer pressure 2.76 bar (40 psi) x 2.0 = initial agitation preset pressure 5.5 bar (80 psi)

Record your  
calculation here:

---

3. With the master section switch in the OFF position and the engine throttle set to the engine speed you intend to run the machine, adjust the preset agitation value until the sprayer system pressure is between 1.5 to 2.0 times the target sprayer pressure identified.

For example, if you are spraying at 2.76 bar (40 psi), initially set Preset Agitation to achieve a system pressure of 4.1 to 5.5 bar (60 to 80 psi).

**Note:** If the chemicals in the sprayer tank are foaming, lower the preset agitation value as necessary to reduce system pressure when tank agitation is running.

4. Navigate to and select the **Agitation** option.
5. While watching the dash mounted sprayer-pressure gauge, press the buttons raise or lower the preset value until the sprayer pressure is at the initial agitation preset pressure calculated above.

**Note:** Do not exceed 586 kPa (85 psi) sprayer system pressure when adjusting the preset agitation value.

**Note:** You may set the preset agitation value higher if agitation does not cause the chemical in the tank to foam. You may need to lower the agitation value if agitation causes the chemical in the tank to foam.

6. Save the setting, exit the **Tank** screen, and return to the **Settings** screen.

## The Total and Sub Area Screens

These screens display:

- Area sprayed (acres, hectares, or 1000 ft<sup>2</sup>)
- Volume sprayed (US gallon or liters)

The area and volume information accumulates until you reset it.

Use an individual sub area for each sprayer task at your site. You can use up to 20 sub areas.

**Note:** Ensure that you navigate to the sub area you are working on before you begin spraying. The sub area shown on the screen is the active sub area for coverage accumulation.

## Resetting the Total Area and Volume Data

1. Press the **BACK** button to navigate to the Total Area screen.
2. Press the **RIGHT** button to reset the Total Area data.

**Note:** Resetting the total area and total volume information at the total area screen resets **all** of the data for every sub area.

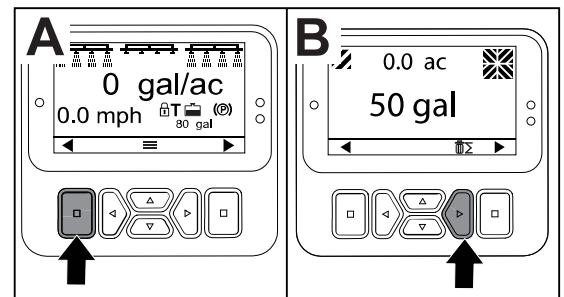

G511618

## Resetting a Sub Area and Volume Data

1. Press the BACK button to navigate to a Sub Area screen.
2. Press the UP button to reset the sub area data

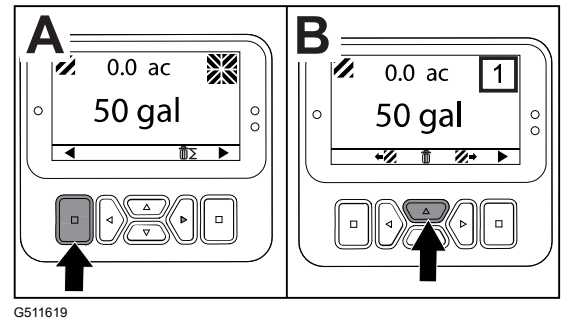

## Calibrating the Sprayer

**Note:** To calibrate the sprayer for manual mode operation, refer to the *Operator's Manual* for the machine.

1. Ensure that the sprayer tank is clean; refer to Cleaning the Sprayer System in the *Operator's Manual*.
2. Navigate to the Calibration menu.

**Note:** This screen displays and allows you to calibrate the flow meter input, calibrate the speed sensor input, perform a speed test, and manually enter calculation data.

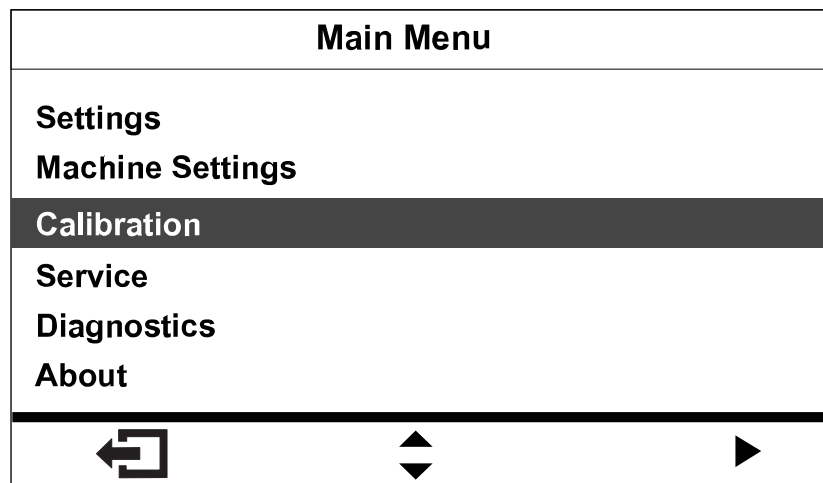

## Calibrating the Flow

**Customer provided equipment:** Use a catch container graduated for the nozzle-flow rate as follows:

- 1.5 Lpm (0.4 gpm) or less - a container graduated in 10 ml (1/2 fl oz) increments is preferred.
- 1.9 Lpm (0.5 gpm) or more - a container graduated in 20 ml (1 fl oz) increments.

## IMPORTANT

**You must perform a flow calibration for 3 sprayer sections each time you replace all nozzles, change to the active spray (down) position, or after replacing the flow meter. You should perform a flow calibration for 3 sprayer sections if you replace several worn nozzles.**

**Note:** Incorrectly performing the catch test results in inaccuracy in flow calibration. The result of these inaccuracies causes the sprayer system to over-apply or under-apply sprayer chemicals.

Perform the flow calibration using the appropriate graduated container.

## Evaluating Flow Calibration Type

Use the Sprayer Sections Table to help determine how you typically spray turf with the machine and which flow calibration to perform.

**Note:** You can perform a combination of up to 3 flow calibration types.

### Sprayer Section Table

	<b>Perform the 3-boom calibration</b>	
3 sprayer sections	Yes	
<b>I also spray with 2 sprayer sections:</b>		
	<b>Perform the 2-Boom Calibration</b>	
Left and Center sections (OR)	Yes	No
Right and Center sections (OR)	Yes	No
Right and Left sections	Yes	No
<b>I also spray with 1 sprayer section:</b>		
	<b>Perform the 1-Boom Calibration</b>	
Left sprayer section only (OR)	Yes	No
Center sprayer section only (Or)	Yes	No
Right sprayer section only	Yes	No

**3 boom calibration:** Always perform the calibration for the 3 sprayer sections when you change the nozzles to increase or decrease the range of application rates.

**Note:** If you do not perform the optional 2 boom calibration or 1 boom calibration, the sprayer uses the calculations from the 3-boom calibration in all sprayer-section combinations.

**Optional 2 boom calibration:** Calibrate the left and center sprayer sections or the right and center sprayer sections or the left and right sections if you typically spray with those section

combinations. Perform this optional calibration after performing the 3 sprayer section calibration.

**Note:** The calibration you perform for two sprayer sections is used whenever you spray with any combination of 2 sprayer sections.

**Note:** You can only calibrate for 1 pair of sprayer sections for the 2 boom calibration. Calibrate from the pair of sprayer sections that you use the most. The sprayer system uses the 2-boom calculation when you spray with either the left and center or right and center section combinations.

**Optional 1-boom calibration:** Calibrate the left or center or right sprayer section if you typically spray with 1 sprayer section. Perform this optional calibration after performing the 3-sprayer-section calibration and 2-sprayer-section calibration.

**Note:** You can only calibrate 1 of the 3 sprayer sections for the 1 boom calibration. Calibrate from the sprayer section that you use the most. The sprayer system uses the 1-boom calibration when you spray with the left, center, or right section.

Evaluate which calibration type to perform based on your spraying pattern.

## Preparing for the Flow Test

1. Ensure that the nozzles that you intend to use are in the active spray (down) position.

---

### IMPORTANT

---

All nozzles in the active position must be the same color.

---

**Note:** For best results, nozzles in the active position should have approximately the same amount of wear.

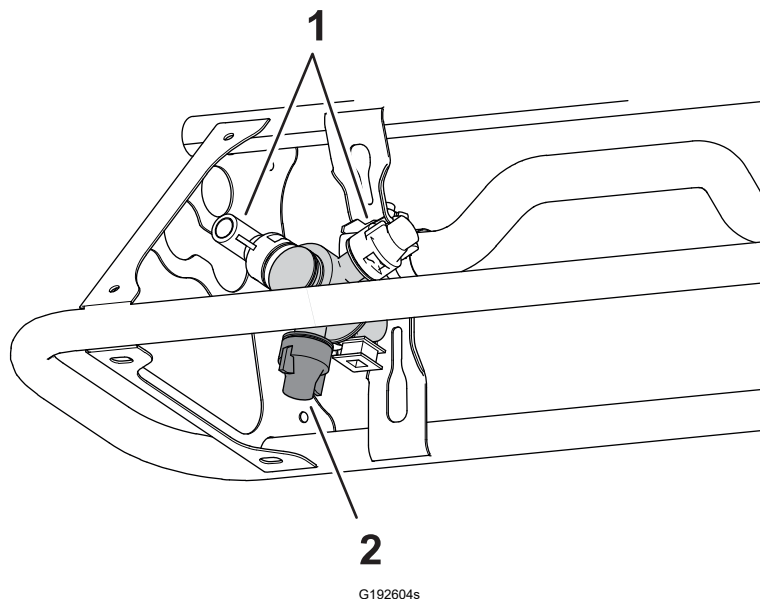

① Reserve nozzle position

② Active spray position

2. Navigate to the **Calibration** menu.

3. Select the **Flow calibration** option.

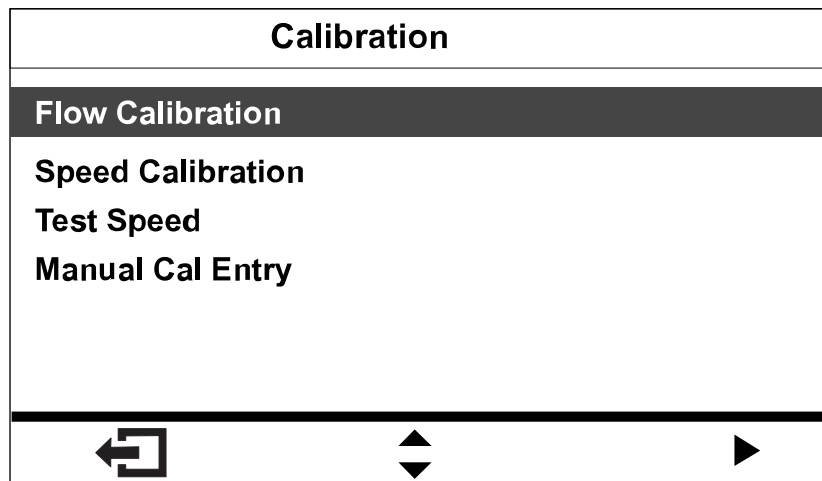

GG580549

4. Fill the sprayer tank half full—700 L or 150 US gallons of water.

**Note:** You can cancel the flow calibration. A message displays confirming that you canceled the flow calibration.

5. Engage the parking brake.

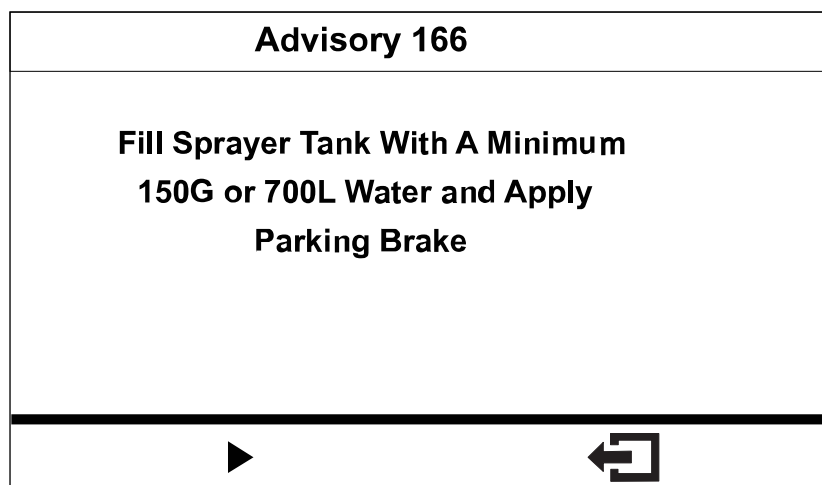

GG580550

6. Start the engine and lower the outer sections.
7. Set the pump switch to the ON position.

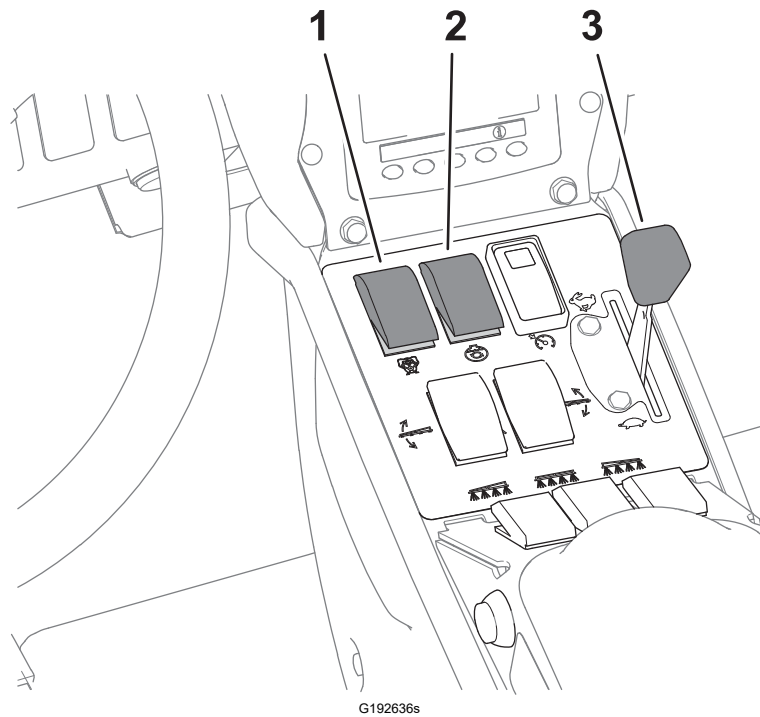

G192636s

- ① Sprayer-pump switch
- ② Agitation switch

- ③ Throttle

8. Move the throttle to the FAST position and allow the engine to run for 10 minutes.

---

## IMPORTANT

---

**You must bring the hydraulic system to operating temperature before proceeding with the remaining flow calibration steps.**

---

# Preparing for the Catch Test

1. Select the nozzles installed at the active spray position.
  - For machines with nozzle colors that match the flow rates described, select the color of nozzles installed at the active spray position.
  - For machines with nozzle colors that *do not match* the flow rates described, select the flow rate (gpm or lpm) of nozzles installed at the active spray position.

Select A Nozzle Color	
<b>Orange</b>	<b>0.10 gpm</b>
<b>Dark Green</b>	<b>0.15 gpm</b>
<b>Yellow</b>	<b>0.20 gpm</b>
<b>Purple</b>	<b>0.25 gpm</b>
<b>Dark Blue</b>	<b>0.30 gpm</b>
<b>Red</b>	<b>0.40 gpm</b>
<b>Brown</b>	<b>0.50 gpm</b>



G580551

2. Advance to the next step.
3. Set the sprayer mode switch to the manual position.

Advisory 166
<b>Set Manual Mode. Close Boom Bypass Valve. Turn On Sprayer Pump. Turn Off Agitation. Set Engine To Full Throttle.</b>



G580552

4. Rotate the knob for the section-bypass shutoff valve to the closed position.
5. Set the agitation switch to the OFF position and set the throttle to the FAST position.
6. Advance to the next step.

# Preparing the Sprayer Section(s) for the Catch Test

1. Set the sprayer section switches as follows:

**Note:** Refer to Preparing for the Flow Test.

- Select the left, center, and right section switches for a **3-sprayer-section calibration**.

---

## IMPORTANT

---

**You must perform this calibration.**

---

- Select the 2 sprayer section switches for the sprayer sections you previously identified for the 2-sprayer-section calibration.

**Note:** Perform this optional calibration after performing the 3-sprayer-section calibration.

- Select the left or center or right section switch for the sprayer section you previously identified for the 1-sprayer-section calibration.

**Note:** Perform this optional calibration after performing the 3-sprayer-section calibration and 2-sprayer-section calibration.

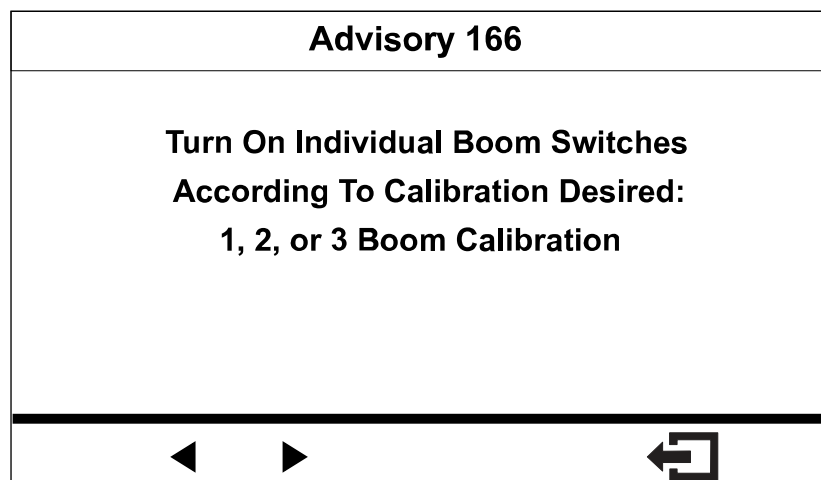

G580553

2. Advance to the next step.
3. At the Repeat the Following Test screen, press the button to start the sprayer section catch test.

## Advisory 166

**Repeat The Following Test Using Manual Rate Switches To Change Pressure Until Measured Volume Equals Target Volume.**



G580554

## Performing the Sprayer Section Catch Test

**Note:** Ready the graduated catch container.

1. Set the master section switch to the ON position.
2. Use the application-rate switch to adjust the sprayer system pressure to approximately 276 kPa (40 psi).

Model 41394 shown

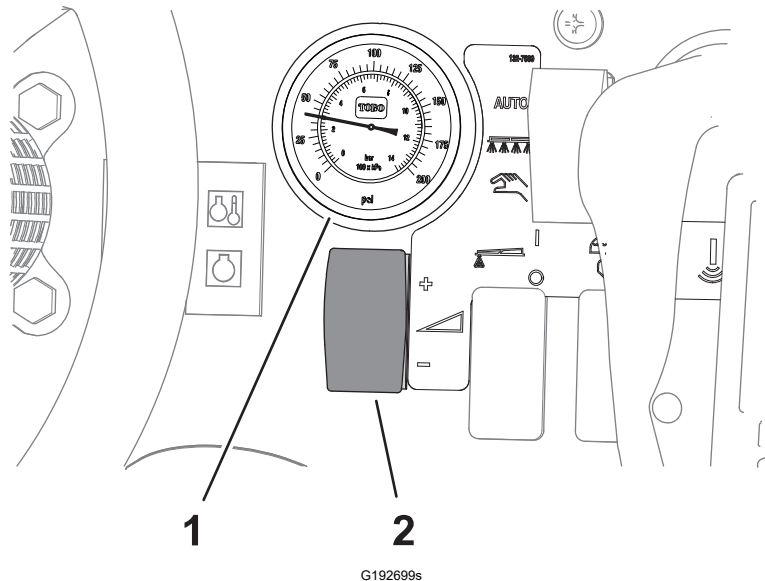

① Pressure gauge (sprayer system)

② Application-rate switch

3. Set the master section switch to the OFF position.
4. At the catch test playback screen, confirm the number of booms, the nozzle color, and press button 3 to start the catch test.

**Note:** You have 14 seconds to move to the back of the machine and position the graduated catch container under a spray nozzle for the catch test period.

**Note:** The sprayer system automatically opens the section valve, the sprayer nozzles spray for the catch test period, and the sprayer system automatically shuts off the section valve.

Start The Catch Test	
Number Of Booms	1
Duration	30s
Target Volume	16 fl oz
Sprayer Pressure	142 psi
Nozzle Color	Purple

G580555

- Catch the water from the sprayer nozzle until the sprayer flow shuts off.

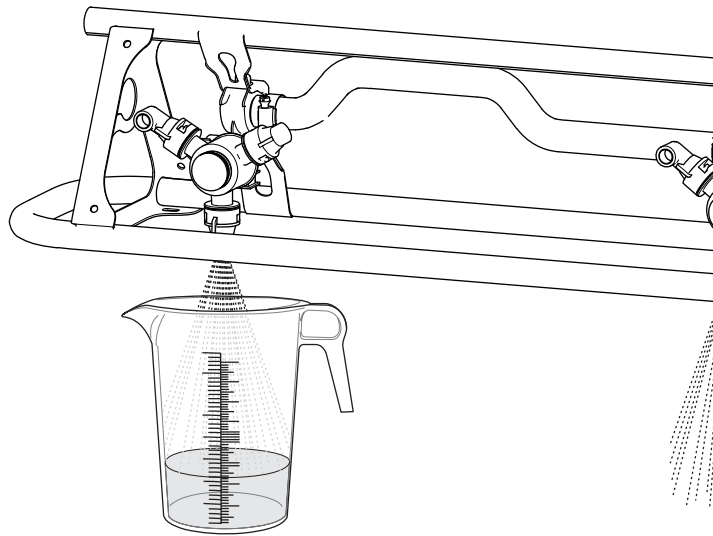

G193177

- Set the graduated container on a level surface and note the fluid volume.

---

### IMPORTANT

---

When you are reading the graduated container, you must set the container on a level surface.

---



---

### IMPORTANT

---

When you are reading the graduated container, read the fluid volume in the graduated container at the lowest point of the fluid-surface curve.

---



---

### IMPORTANT

---

Small errors reading the fluid volume in the graduated container significantly impacts the accuracy of the sprayer calibration.

---

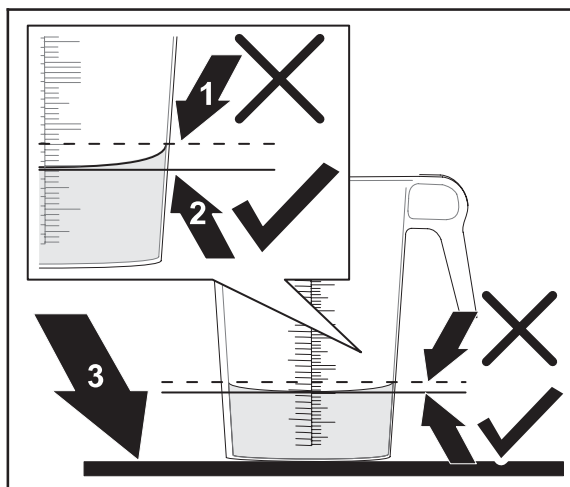

G193416s

- |   |   |
|---|---|
| <p>① Highest point of the fluid-surface curve (do not measure here)</p> | <p>② Lowest point of the fluid-surface curve (measure here)</p> |
|   | <p>③ Level surface</p>  |

7. Compare the volume of fluid in the graduated catch container with the Target Volume displayed on the display screen.

**Note:** You need the volume of fluid in the graduated catch container  $\pm 7.4$  ml (1/4 fl oz) of the Target Volume displayed on the display screen.

8. If the fluid level in the graduated catch container is 7.4 ml (1/4 fl oz) more than the target volume or 7.4 ml (1/4 fl oz) less than the target volume, perform one of the following:
- If the volume of fluid in the graduated catch container is  $\pm 7.4$  ml (1/4 fl oz) of the Target Volume displayed on the display screen, proceed to the next step.
  - If the volume is too low, use the application-rate switch to raise the sprayer system pressure and proceed to the next step.
  - If the volume is too high, use the application-rate switch to lower the sprayer system pressure and proceed to the next step.
9. Repeat the steps until the volume of fluid in the graduated catch container is  $\pm 7.4$  ml (1/4 fl oz) of the Target Volume displayed on the display screen.

# Performing the Calibration Calculation

1. Set the master section switch to the On position.

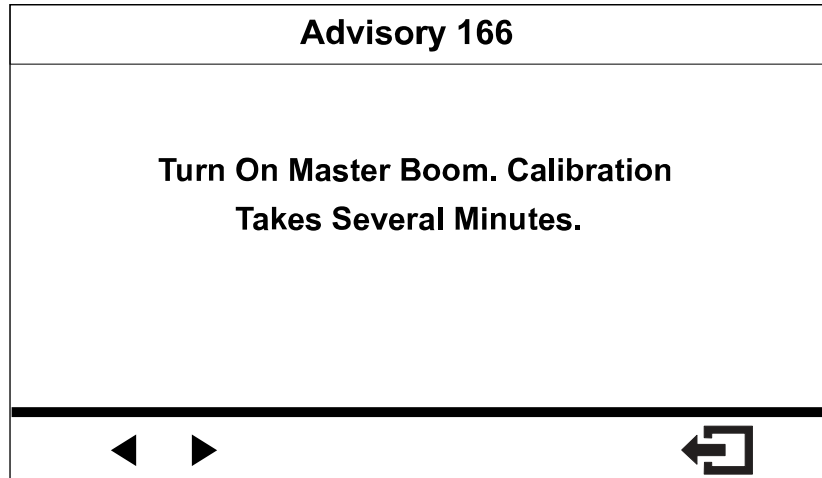

G580556

2. Press the button to begin the calibration calculation.

**Note:** The screen displays the calibration in process screen.

**Note:** The sprayer sections spray out for 3 minutes while the machine is calculating the calibration correction.

3. When the calibration process ends, one of the following messages is displayed:

- A message displays confirming that the flow calibration is successful.
- A message displays indicating that the flow calibration has failed.

If the calibration value is out of bounds, contact your authorized service dealer; otherwise, review the error message and repeat the calibration steps.

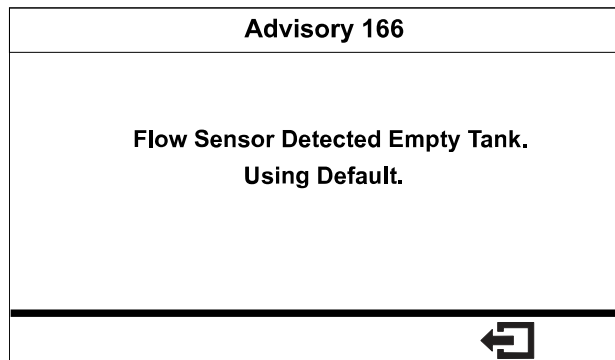

G580547

4. Move the throttle to the IDLE position, shut off the engine, and remove the ignition key.

## Performing the 2 Sprayer-Section Calibration

If you completed a 3-sprayer-section calibration, the display prompts you for a 2-sprayer-section calibration.

1. If you do not need to perform the 2-sprayer-section calibration, return to the Calibrate screen.
2. If you do need to perform the calibration, prepare the sprayer for a catch test.

**Note:** You will set only the sprayer section switches to the ON position that you previously identified.

## Performing the 1 Sprayer-Section Calibration

If you completed a 3-sprayer-section and 2-sprayer-section calibration, the display prompts you for a 1-sprayer-section calibration.

1. If you do not need to perform the 1-sprayer-section calibration, return to the Calibrate screen.
2. If you do need to perform the calibration, prepare the sprayer for a catch test.

**Note:** You will set only the sprayer section switches to the ON position that you previously identified.

# Speed Calibration

## Preparing for the Speed Calibration

1. Select Speed Calibration from the Calibration menu.

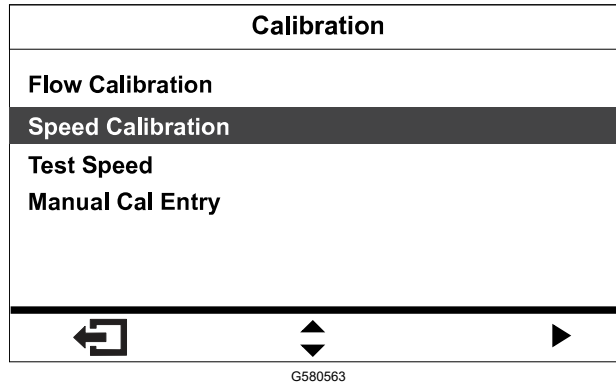

2. Fill the sprayer tank half full—600 L or 150 US gal of water.

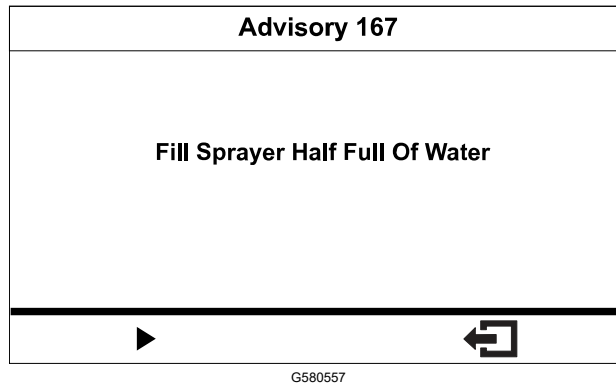

3. Mark a starting line on a testing area of turf.
4. Using a measuring wheel, mark off a 45 to 152 m (150 to 500 ft) distance; record the distance that you measured below.  
**Note:** A test distance to 92 to 152 m (300 to 500 ft) produces better calibration results.

Distance: \_\_\_\_\_

5. Mark a finishing line on a testing area of turf.

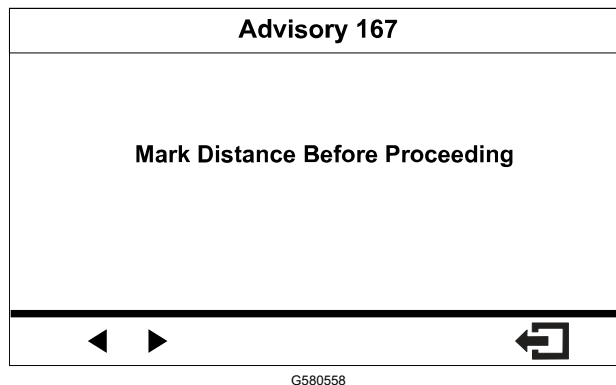

6. Use the buttons on the display to change the entered-distance value.

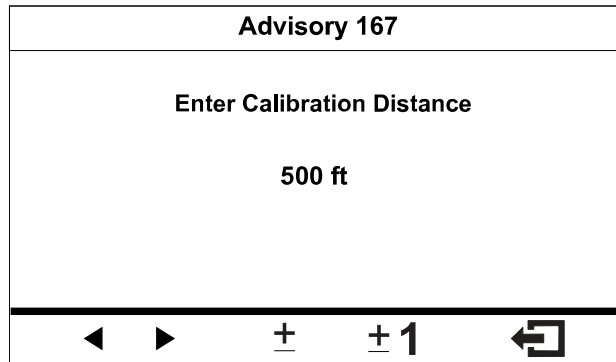

G580559

## Performing the Speed Calibration

1. Move the machine to align the front tires on the starting line.
2. At the center console of the machine, ensure that the switches for the 3 section valves are in the OFF position.

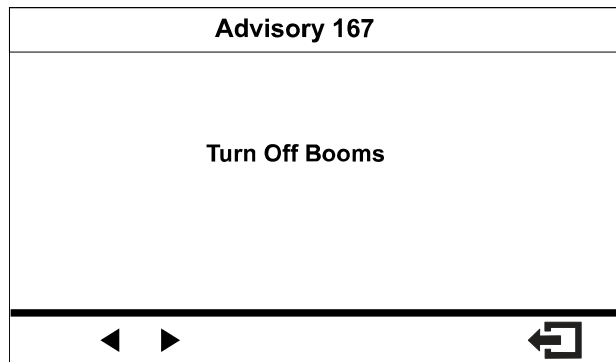

G580560

3. Press the navigation button on the display to begin and drive to the finishing line.

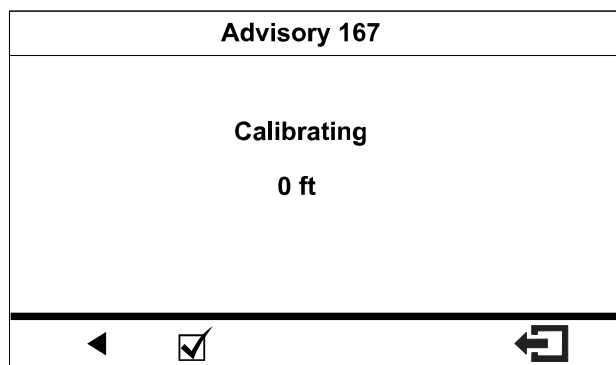

G580561

The measured distance value should rise.

4. Press the navigation button when the front tire of the machine is on the finish line.  
**Note:** If the measured-distance value and the entered-distance value do not match, the computer of the sprayer system automatically corrects the measured-distance value.
5. When the calibration process ends, one of the following messages is displayed:

- A message displays confirming that the flow calibration is successful.
- A message displays indicating that the flow calibration has failed.

If the calibration value is out of bounds, contact your authorized service dealer; otherwise, review the error message and repeat the calibration steps.

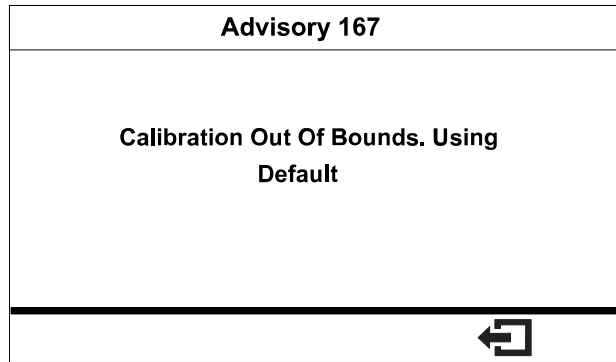

G580562

6. Move the throttle to the **SLow** position, shut off the engine, and remove the ignition key.

# Troubleshooting

## Advisories

Operator advisories automatically display on the InfoCenter screen when a machine function requires additional action. For example, if you attempt to start the engine while pressing the traction pedal, an advisory displays, indicating that the traction pedal must be in the NEUTRAL position.

Press any buttons on the display to clear the advisory.

160	Start Prevented—Pump switch active
160	Start Prevented—Not in NEUTRAL
160	Start Prevented—Out of seat
160	Start Prevented—Starter engage timeout
160	Start Prevented—Rinse pump is On
161	Engine Stop—Out of seat
161	Engine Stop—Parking brake is engaged
162	Pump Start Prevented—Boom active
162	Pump Start Prevented—Operator not in seat or parking brake in engaged
162	Pump Start Prevented—Stop cranking the engine
162	Pump Start Prevented—Operator not in seat
164	Tank Status—Tank low volume alert
164	Tank Status—Rinse pump is on
165	Parameter Status—Invalid parameter value
165	Parameter Status—Invalid parameter range value
168	Booms Turned Off—Speed too low

## Service Fault Codes

The list below identifies the fault codes that are generated by the Electronic Controller (TEC) to identify an electrical system malfunction that occurred during machine operation.

If you see faults listed in the viewer, contact your Authorized Service Dealer.

Code	Description
1	TEC is faulty
2	One or more of the TEC output fuses (7.5 A) is faulty
3	Main power relay or circuit wiring is faulty

<b>Code</b>	<b>Description</b>
4	Charging system or circuit wiring is faulty
14	InfoCenter software is not recognized by TEC
17	Starter timeout (starter has been engaged for more than 30 seconds)
18	The traction pedal does not match the ground speed.
19	No signal from the flow rate meter

**Notes:**

**Notes:**

